

(19) **DANMARK**

(10) **DK/EP 1871141 T4**



(12) **Oversættelse af ændret
europæisk patentskrift**

Patent- og
Varemærkestyrelsen

-
- (51) Int.Cl.: **H 04 R 25/00 (2006.01)**
- (45) Oversættelsen bekendtgjort den: **2017-07-10**
- (80) Dato for Den Europæiske Patentmyndigheds bekendtgørelse om opretholdelse af patentet i ændret form: **2017-04-19**
- (86) Europæisk ansøgning nr.: **07110517.5**
- (86) Europæisk indleveringsdag: **2007-06-19**
- (87) Den europæiske ansøgnings publiceringsdag: **2007-12-26**
- (30) Prioritet: **2006-06-19 US 814858 P**
- (84) Designerede stater: **AT BE BG CH CY CZ DE DK EE ES FI FR GB GR HU IE IS IT LI LT LU LV MC MT NL PL PT RO SE SI SK TR**
- (73) Patenthaver: **Sonion Nederland B.V., Zekeringstraat 9, 1014 BM Amsterdam, Holland**
- (72) Opfinder: **Zeger van Halteren, Aart, Oud Raeffeldamweg 2, 1447 EG Hobrede, Holland**
- (74) Fuldmægtig i Danmark: **Inspicos P/S, Kogle Alle 2, 2970 Hørsholm, Danmark**
- (54) Benævnelse: **Høreapparat med to lydgivere som hver især forstærker et forskelligt frekvensområde**
- (56) Fremdragne publikationer:
EP-A- 1 617 704
US-A- 4 548 082
US-A- 4 629 833
US-A- 6 072 885
EP-A1- 1 681 904
WO-A1-2007/022773
DE-C2- 2 303 194
US-A- 5 737 436
US-A1- 2002 061 113
US-A1- 2002 164 041
US-B1- 6 292 571
US-B1- 6 748 094

DESCRIPTION

FIELD OF THE INVENTION

[0001] This invention relates to hearing aids, and, more particularly, to a hearing aid having two receivers each amplifying a different frequency range.

BACKGROUND OF THE INVENTION

[0002] Today's hearing aids include only one receiver that, together with the hearing-aid acoustics (tubing, wax protection devices, etc.) connected to it, has a resonance frequency that lies between 2 kHz and 3.5 kHz. There are two primary reasons for this limitation. First, the unoccluded ear has significant gain in this frequency range, which is removed by blocking the open ear canal with an closed-fitting earmold. Second, in order to achieve an acceptable output and efficiency at both low and high frequencies, the resonance frequency is selected to be somewhere in the middle of the required frequency range (e.g., 300 Hz to 6 kHz). If the resonance frequency is increased above 3.5 kHz, the efficiency would be too low for the low frequencies though it would improve the response above 4 kHz considerably. US-A-4629833 discloses a hearing aid device having a plurality of sound sources for supplying sound to a shared acoustic transmission arrangement. Two earpiece receivers standard in hearing aids can be employed as the sound sources, these being driven from the amplifier of the device. The acoustic outputs of these earpiece receivers are then combined with one another in a sound transmission arrangement to the ear. For purposes of adjustment, acoustic means such as nozzles, filters, etc. can be employed in the acoustic paths of the earpiece receivers and also in the sound transmission arrangement leading to the ear. Variable means designed, for instance, as a valve, can also be employed in the lines, their cross-sections being variable therewith. The acoustic effect of the earpiece receivers, however, can also be balanced (or matched) by means of differing operation of the electrical excitation of the two earpiece receivers. Such a balancing can then take place, for instance, by means of differing variation of the volume emitted by the individual earpiece receivers. It is also disclosed to employ a separate output stage for each earpiece receiver.

[0003] There is a trend to increase the bandwidth of the hearing aid, but this trend is particularly difficult to apply to behind-the-ear (BTE) hearing aids because the long sound tubing inserted between the receiver sound port and the sound outlet of the ear mold suppresses the high frequencies. Bandwidth enhancement in general has been limited by the available processing power of the DSPs within the hearing aid, in which the audio sampling rates typically have been limited to a sample rate of about 16 kHz with a resulting audio bandwidth slightly below 8 kHz. In the increasingly popular open-fitting "over-the-ear" (OTE) hearing aids, overall performance with respect to frequency bandwidth and efficiency can be improved by placing the receiver deeper inside the user's ear canal.

[0004] Thus, a need exists for improved hearing aids that will amplify and output substantial sound pressure in the frequency range above 8 kHz in addition to the ordinary sound pressure output in the frequency range 100 Hz to 8 kHz. The present invention is directed to satisfying one or more of these needs and solving other problems.

SUMMARY OF THE INVENTION

[0005] A receiver system for a hearing aid assembly according to claim 1.

[0006] Alternatively, the present invention is a hearing aid assembly according to claim 2.

[0007] Additional aspects of the invention will be apparent to those of ordinary skill in the art in view of the detailed description of various embodiments, which is made with reference to the drawings, a brief description of which is provided below.

BRIEF DESCRIPTION OF THE DRAWINGS

[0008]

FIG. 1a is a side view of a device having two receivers, one disposed in a tube connected to an output port of the other;

FIG. 1b is an illustration of a high-frequency receiver with standoffs for placement within a tube connected to an output port of a low-frequency receiver;

FIG. 1c is an end perspective view of the high-frequency receiver shown in FIG. 1a disposed within a tube;

FIG. 2 is an illustration of a hearing aid shell having a low-frequency receiver coupled to an earhook by a tube and a high-frequency receiver also coupled to an earhook;

FIG. 3 is a variation of the hearing aid shown in FIG. 2 in which the high-frequency receiver is disposed in the earhook;

FIG. 4a is an illustration of a hearing aid shell with an earmold connected to the earhook of the hearing aid, a high-frequency receiver being disposed within a tube connecting the earmold;

FIG. 4b is a perspective illustration of a high-frequency receiver having a cylindrical shape with a channel formed therethrough and a protruding output port according to an embodiment of the present invention;

FIG. 4c is a perspective illustration of a cylindrically shaped high-frequency receiver having a channel formed therethrough without a protruding output port according to another

embodiment of the present invention;

FIG. 4d is an illustration of a side view of a high-frequency receiver disposed within a tube such that there is space for low frequency sounds to flow past the high-frequency receiver according to an embodiment of the present invention;

FIG. 4e is a variation of FIG. 4d in which the high-frequency receiver includes a channel formed therethrough for allowing the low frequency sounds to pass therethrough according to another embodiment of the present invention;

FIG. 4f is an illustration of an earmold having two receivers, one placed so that it fits just behind the wearer's tragus;

FIG. 5a is an illustration of an "open ear" type hearing aid having a high-frequency receiver disposed in an earbud tethered to the hearing aid shell by a tube, which is coupled to a low-frequency receiver inside the housing by a tube;

FIG. 5b is an illustration of a high-frequency receiver having a size adapted to fit within double plastic earbuds;

FIG. 6 is a functional block diagram of electronics suitable for use in embodiments of the present invention; and

FIG. 7 is a flow-chart diagram of alternate methods.

DETAILED DESCRIPTION OF THE INVENTION

[0009] There are at least three considerations in optimizing hearing aids in general: (1) its size should be as small as possible; (2) its power consumption should be as small as possible; and (3) its maximum sound pressure output should, as a general rule, be as high as possible. Another consideration is also becoming very important: (4) bandwidth should be as high as possible. The present invention achieves optimization of all four of the foregoing considerations by providing two receivers, each of which is separately optimized for different frequency ranges.

[0010] Though the addition of a second receiver may appear at first blush to increase overall size, in fact, each receiver can be optimized to a smaller size and can be distributed in the hearing aid in different areas or orientations, thereby saving overall space. By providing a separate receiver specially optimized at low frequencies, the resonance frequency is lowered, substantially increasing low frequency efficiency when compliance is increased. For the high frequencies, efficiency is less important because most of the energy in normal situations is related to frequencies below 500 Hz. To decrease power consumption for the high frequencies, the mass of the high-frequency receiver is lowered, which is easier to do in a device that needs

to reproduce high frequencies only. Lowering the mass of the high-frequency receiver also advantageously improves acoustical feedback, which is generally only important for frequencies above about 1 kHz.

[0011] Maximum sound pressure output can be increased with separately optimized receivers because each resonance can be shifted to a frequency where maximum output is of prime importance. For the high-frequency receiver, its desired resonance may still be around the unoccluded ear resonance. But for the low-frequency receiver, its resonance can be selected to increase maximum output. Present-day balanced armature receivers are ill-suited for this sort of optimization.

[0012] The dual-receiver aspects of the present invention also permit the bandwidth to be optimized with a sufficient amount of output. A high-frequency receiver with a significantly higher resonance frequency than 3.5 kHz can achieve a usable bandwidth of up to 15 kHz. This range of bandwidth is particularly suited to address mild to moderate hearing loss as well as for use in communication devices such as mobile phones, earphones, headphones, headsets, and the like.

[0013] In an embodiment, the low-frequency receiver has a bandwidth of about 8 kHz and a high-frequency driver can be added as needed because of the positioning required within a particular hearing aid or because of the functionality needed for a particular application. This embodiment supports a platform scheme whereby certain functionality is disabled or eliminated for lower-priced variants.

[0014] As used herein, "low frequency" includes frequencies below about 1.2 kHz and "high frequency" includes frequencies above about 1.2 kHz. Very high frequencies include frequencies above about 7 kHz.

[0015] Turning now to the Figures, and initially to FIGS. 1a-1c, a receiver system 100 according to an embodiment of the present invention is shown. The receiver system 100 includes a low-frequency receiver 102 and a high-frequency receiver 104 positioned within a tube 112 that is connected to an output port 106 of the low-frequency receiver 102. The interface between the tube 112 and the output port 106 forms a tight acoustical seal to prevent leakage. The low-frequency receiver 102, the high-frequency receiver 104, and the tube 112 are housed within a housing 116 that is sized to fit within an average person's ear canal. The housing 116 may contain the electronics required for operation of the receiver system 100.

[0016] The high-frequency receiver 104 includes standoffs 110a, 110b (FIGS. 1b and 1c) disposed about a periphery of the high-frequency receiver 104 such that when the high-frequency receiver 104 is positioned within the tube 112, the low-frequency acoustic sounds emanating from the output port 106 of the low-frequency receiver 102 are able to flow around the high-frequency receiver 104. High-frequency acoustic sounds are outputted from an output port 108 of the high-frequency receiver 104, which are combined with the low-frequency acoustic sounds that flow around the high-frequency receiver 104 due to the standoffs 110a,

110b shown in FIGS. 1b and 1c.

[0017] The low-frequency receiver 102 is connected to the internal electronics (e.g., the DSP) in the customary way by wires or with conductive springs. Wires 114a, 114b from the high-frequency receiver 104 extend down the tube 112 in the illustrated embodiment for connection to processing electronics (described in connection with FIG. 6 below) including a DSP. Alternately, the wires 114a, 114b may be connected to inner conductive electrodes disposed along the tube 112, which carry the electrical audio signals from the processing electronics to the wires 114a, 114b. The wires 114a, 114b are preferably very thin litze wires that can easily fit around the output port 106 of the low-frequency receiver 102 within the tube 112. In another embodiment, the standoffs 110a,b include conductive strips and connect to corresponding conductive electrodes formed along the interior of the tube 112 proximate where the standoffs 110a,b contact the tube 112. In another embodiment, the tube 112 is a flexprint having conductive traces formed along its surface for connection to the electrodes of the high-frequency receiver 104. The use of conductive portions on the tubing 12 is preferred in BTE and OTE types of hearing aids. When only one DSP is used in the system, one contact for the receivers may be acceptable, and when no capacitive filtering (crossover) for the high-frequency receiver 104 is used, both contacts for the receivers can be used.

[0018] In behind-the-ear or on/over-the-ear listening-device implementations, the present invention offers great flexibility regarding the placement of the low-frequency and high-frequency receivers. In existing hearing-aid designs, a receiver is placed near the battery, which advantageously reduces overall size, but a very long tubing is required to guide the output acoustic sounds from the receiver output port to the ear canal. The long tubing causes the high frequencies to suffer. The present invention avoids this and other drawbacks by placing a high-frequency receiver near the entrance of the earhook, while the low-frequency receiver is connected by a tube to the earhook, such as shown in FIG. 2. The low frequencies are generally unaffected by the tubing length.

[0019] The hearing aid 200 shown in FIG. 2 includes a housing 216 that houses a low-frequency receiver 202 connected to a tube 212, and a high-frequency receiver 204 that is located near the entrance of an earhook 220 of the hearing aid 200. A Y-shaped tube 224 within the earhook 220 connects to an output port 206 of the low-frequency receiver 202 and to an output port 208 of the high-frequency receiver 204. In the illustrated embodiment, the tube 212 is connected to the earhook 220 just at about the same plane where the earhook 220 is connected to the hearing aid 200. The tube 224 can also have a T-shape as well.

[0020] An alternate embodiment not according to the invention is shown in FIG. 3 wherein a high-frequency receiver 304 is placed inside an earhook 320 of a hearing aid 300. Because the high-frequency receiver 304 only has to provide high frequencies (or very high frequencies such as above 7 kHz), it can be made small enough to fit inside the earhook 320. The high-frequency receiver 304 may have a generally rectangular or cylindrical shape sized to fit within the earhook 320.

[0021] FIG. 4a illustrates another embodiment in which a high-frequency receiver 404 is placed in an earmold tube 426 of a hearing aid 400, which is of the behind-the-ear (BTE) type having a closed-fitting earmold 430 (alternately, the high-frequency receiver 404 may be placed in or near the earpiece tip of an open-fit hearing aid, which is placed in the ear canal, such as shown in FIG. 5a below). The earmold tube 426 connects an earhook 408 of the hearing aid 400 to the earmold 430. Wires 414a,b connected to the high-frequency receiver 404 extend away therefrom and connect to electrodes disposed in the earmold tube 426. The hearing aid 400 includes a housing 416 that houses a low-frequency receiver 402 having an output port 406 connected to a tube 412 extending through the earhook 408 and connecting to the earmold tube 426. An output port 420 of the high-frequency receiver 404 is much closer to the ear canal than the low-frequency receiver 402.

[0022] The high-frequency receiver 404 is shown in FIGS. 4b and 4c as having a substantially cylindrical shape. In FIG. 4c, the output port 420b of high-frequency receiver 404b does not protrude as in FIG. 4b. A cylindrically shaped receiver suitable for this embodiment is disclosed in commonly owned, copending U.S. Patent Application No. 09/992,253, entitled Acoustical Receiver Housing for Hearing Aids, filed November 16, 2001, published as U.S. Patent Application Publication No. 2002/0061113 on May 23, 2002. The receiver shown in FIGS. 7a and 7b of Publication No. 2002/0061113 can be made smaller because it would be optimized for high frequencies only. Either receiver 404 or 404b shown in FIGS. 4b and 4c is suitable for use in the hearing aid 400 shown in FIG. 4a. The high-frequency receivers 404, 404b include a channel 424a, 424b, respectively, running through the center of the length of the receivers. The channels 424a,b permit the low-frequency sounds from the upstream low-frequency receiver 402 to pass through the receiver 404, 404b. The low-frequency acoustic sounds are combined with high-frequency acoustic sounds outputted by the output port 420, 420b, to form a full-range acoustic sound that is transmitted to the wearer's ear canal.

[0023] FIG. 4d is an illustration of a high-frequency receiver 404, which may have a rectangular or cylindrical shape, disposed within a shaped tube 426a having a recessed area for receiving the high-frequency receiver 404 as shown. Low frequency acoustic sounds enter the shaped tube 426a at tube input 440 and pass around the high-frequency receiver 404 in the direction of arrow LF. High frequency acoustic sounds are combined with the low frequency acoustic sounds at the output port 420 of the high-frequency receiver 404, and together they leave the tube 426a at tube output 442 as a full-range acoustic sound. The wires 414 pass through the tube 426a and are connected as described above either to electrodes disposed along the tube 426a or at the interface of an acoustical/electrical connector that creates an acoustic seal as well as providing electrical connectivity for the wires 414 to the hearing-aid electronics.

[0024] The high-frequency receiver 404 shown in FIG. 4e has a substantially cylindrical shape and fits snugly within a tube 426b. Upstream low-frequency acoustic sounds pass through the tube in the direction of arrow LF and also through the high-frequency receiver 404 via the channel 424b and are combined with the high-frequency acoustic sounds outputted by the high-frequency receiver 404 at its output port 420b to form a full-range acoustic signal that is

transmitted to the wearer's ear canal in the direction of arrow LF+HF. Wires 414a,b pass through the tube 426b and carry the driver signals to the high-frequency receiver 404. The wires 414a,b are connected upstream either at a connector interface that offers both acoustical sealing and electrical connectivity or along an electrode formed along the tube 426b as discussed above. Alternatively, two high-frequency receivers 404 (each operational at a specific range) can be placed in the tube 426b with space left between the receivers for passing the LF signal.

[0025] The embodiments shown in FIGS. 4d and 4e do not require that the high-frequency receiver 404 include stand-offs to orient and position it within the tube 426a,b. In alternate embodiments, the high-frequency receiver 404 may include stand-offs such as shown and described in connection with FIGS. 1a-1c.

[0026] The closed-fitting design allows the high-frequency receiver to be placed outside of the ear. Such placement advantageously avoids the adverse effects of ear wax and other intra-ear obstructions that can degrade receiver performance.

[0027] The present invention offers great flexibility in positioning the high-frequency receiver. The low-frequency receiver, when placed in the hearing-aid shell, can be large and powerful for outputting low frequency acoustic sounds. Its compliance can be optimized independently of the high-frequency receiver, which can be optimized for the smallest possible size and lowest possible mass independently of the low-frequency receiver. The high-frequency receiver can be placed so that it sits just behind the wearer's tragus, such as in area 440 shown in FIG. 4a. The high-frequency receiver can be colored black or a skin-color-matching plastic or coating can surround the receiver to blend with the wearer's skin color, rendering the receiver nearly invisible.

[0028] In another embodiment shown in FIG. 4f, the low-frequency receiver 402 is placed in the earmold 430 and the high-frequency receiver 404 is placed near the tragus (an end view is shown in FIG. 4f such that the receiver 404 is oriented towards the wearer's ear canal), which is the small piece of skin-covered cartilage that protrudes slightly over the entrance to the ear canal. In such an embodiment, a sound tube would lead from the earmold 430 to the high-frequency receiver. A receiver roughly the size of an FK-series receiver commercially available from Knowles Electronics has been found to fit nicely behind the tragus, and, of course, smaller receivers would fit as well.

[0029] An open-fit design of an OTE/BTE hearing aid 500 is shown in which a high-frequency receiver 504 is placed within an earbud 530 that is tethered to a shell 516 of the hearing aid 500 by an earbud tube 526 that carries the wires connected to the high-frequency receiver 504 to electronics (not shown) within the shell 516. A block diagram of electronics suitable for use in connection with embodiments of the present invention is shown and described in connection with FIG. 6 below.

[0030] The shell 516 houses a low-frequency receiver 502 having an output port 506 for

outputting low-frequency acoustic sounds to a tube 512 that is connected to the earbud tube 526. Low frequency acoustic sounds outputted by the low-frequency receiver 502 travel through the tubes 512, 526 and are combined with the high frequency acoustic sounds outputted by the high-frequency receiver 504 in the earbud 530.

[0031] As is known with open fittings, sounds at the high frequencies tend to leak out, creating a loss of range at the high frequencies for the listener. However, the present invention minimizes this adverse effect in open-fittings in that the high-frequency receiver can be disposed deep within the ear canal in open-fit designs, and high frequencies do not suffer by virtue of having to travel through a long tube. The adverse effects of feedback are also effectively counteracted by the present invention because the high-frequency receiver can be located far away from the microphone.

[0032] The earbud 530 may be a double-plastic earbud that permits deep insertion of the earbud 530 into the ear canal, achieving a much better high-frequency reduction of the sound that goes outside. The high-frequency receiver 504 can be wedged between the plastic pieces 550a,b of the double-plastic earbud 530 such as shown in FIG. 5b.

[0033] FIG. 6 is a functional block diagram of electronics 600 suitable for use in connection with embodiments of the present invention. The electronics include an optional analog-to-digital converter 608, a digital signal processor (DSP) 610, a digital-to-analog converter 612, a low-frequency amplifier or driver 614, and a high-frequency driver or amplifier 616. Note that the foregoing components may be disposed on separate substrates or on a single substrate or any combination of substrates. The optional ADC 608 is connected to a microphone 606, which may output an analog audio signal (in which embodiment the ADC 608 would be used) or it may output a digital audio signal (in which embodiment the ADC 608 would not be needed). The microphone 606 may be a digital MEMS microphone, such as the DigiSiMic™, or an analog silicon-based microphone, such as the SiMic™, both of which are available from Sonion MEMS A/S. Alternately, the microphone 606 may be any conventional silicon or non-silicon-based microphone.

[0034] The low-frequency driver 614 is connected to a low-frequency receiver 602 and is specially optimized for outputting low-frequency audio signals that are converted into corresponding low-frequency acoustic sounds by the low-frequency receiver 602. Likewise, the high-frequency driver 616 is connected to a high-frequency receiver 604 that is physically separate from the low-frequency receiver 602 and is specially optimized for outputting high-frequency audio signals that are converted into corresponding high-frequency acoustic sounds by the high-frequency receiver 604. The electronics 600 are housed within the shell of the hearing aid, which may be of the ITC (in the canal, which is widely used), MIC (mostly in the canal), CIC (completely in the canal), ITE (in the ear), BTE (behind the ear), or OTE (over the ear or open fit) types.

[0035] In various embodiments, the DSP 610 can be clocked for "normal" band or wideband frequency ranges. For example, the DSP 610 may be clocked with a resulting bandwidth of 6

kHz rate for normal band, or can be clocked higher to result in to 12 kHz or 16 kHz for wideband.

[0036] The high-frequency receivers for use in the embodiments of the present invention are generally cylindrical or rectangular in shape, and may be of the following types: balanced armature, moving coil, piezo. Moving coil receivers have higher efficiency for high frequencies as compared to low frequencies, so moving coil receivers could be more advantageous for high-frequency optimization. For low outputs, it may be more advantageous to utilize a piezo-type receiver. If efficiency is not the main driver (such as in the design of rechargeable hearing aids), the low-frequency receiver may be of the moving coil type. Use of a balanced armature-type receiver for the low-frequency receiver, the low-frequency efficiency can be increased while lowering compliance and distortion (thicker armature, less saturation).

[0037] Though most embodiments described herein are targeted at wideband (e.g., up to 10 kHz) hearing aids, the present invention in other embodiments can also be applied to hearing aids with limited or "normal" bandwidth. For example, in a limited-bandwidth embodiment, a super-power hearing aid includes a low-frequency receiver in its shell that generates frequencies up to around 1 kHz or 1.5 kHz. A high-frequency receiver in the earmold or earbud generates frequencies from the 1 or 1.5 kHz to around 3.5 kHz range. In this embodiment, the hearing aid can be optimized for optimal feedback suppression because the feedback-generating high frequencies are generated far away from the microphone(s). The low-frequency receiver can be optimized for a lower mechanical resonance frequency, resulting in higher efficiency for the low frequencies and high output as well.

[0038] FIG. 7 illustrates a flow-chart diagram of a method 700. A tube is connected to the output of a low-frequency (LF) receiver (702). A high-frequency (HF) receiver is positioned within the tube downstream of the LF receiver output, or, alternately, the HF receiver is positioned downstream of the LF receiver output and proximate the tube (instead of within the tube) (706). Optionally, the LF receiver is placed in a hearing-aid shell. According to the method 700, the LF receiver and the HF receiver are physically separate and distant from one another.

[0039] Although one more component is used (a second receiver) as compared with conventional hearing aid designs, the present invention counter-intuitively allows space to be optimized, resulting in a smaller overall hearing aid. This is because the tubing allows the low-frequency receiver's orientation to be optimized, without regard for the orientation's effect on high frequencies, for best use of space within the hearing-aid shell. The tubing from the low-frequency receiver can be made longer if needed because only high frequencies are adversely affected by the tubing length.

REFERENCES CITED IN THE DESCRIPTION

This list of references cited by the applicant is for the reader's convenience only. It does not form part of the European patent document. Even though great care has been taken in compiling the references, errors or omissions cannot be excluded and the EPO disclaims all liability in this regard.

Patent documents cited in the description

- US4629833A [0002]
- US99225301A [0022]
- US20020061113A [0022] [0022]

PATENTKRAV**1. Høreapparatnordning omfattende:**

et hus med en første lyd giver til frembringelse af lavfrekvent lyd og en lyd kanal, som er akustisk forbundet med en udgangsport af den første lyd giver, en anden lyd giver placeret uden for huset og akustisk forbundet med den første lyd giver, idet den anden lyd giver frembringer højfrekvent lyd, og et øreprop rør, som er forbundet mellem en ørebøjle (earhook) på høreapparatet og en øreprop, hvilket øreprop rør er akustisk forbundet med lyd kanalen, idet den anden lyd giver er placeret i øreprop røret, således at den lavfrekvente lyd, som er frembragt af den første lyd giver, forplanter sig omkring den anden lyd giver og forenes med den højfrekvente lyd, som er frembragt af den anden lyd giver.

2. Høreapparatnordning omfattende:

et hus med en første lyd giver til frembringelse af lavfrekvent lyd og en lyd kanal, som er akustisk forbundet med en udgangsport af den første lyd giver, en anden lyd giver placeret uden for huset og akustisk forbundet med den første lyd giver, idet den anden lyd giver frembringer højfrekvent lyd, og et øreprop rør, som er forbundet mellem en ørebøjle (earhook) på høreapparatet og en øreprop, hvilket øreprop rør er akustisk forbundet med lyd kanalen, idet den anden lyd giver har en overvejende cylindrisk form og en kanal, som passerer gennem den anden lyd giver, idet den anden lyd giver er placeret i øreprop røret for at ligge an mod øreprop rørets indre væg, idet den lavfrekvente lyd, som er frembragt af den første lyd giver, passerer gennem kanalen for at blive forenet med den højfrekvente lyd, som er frembragt af den anden lyd giver.

DRAWINGS

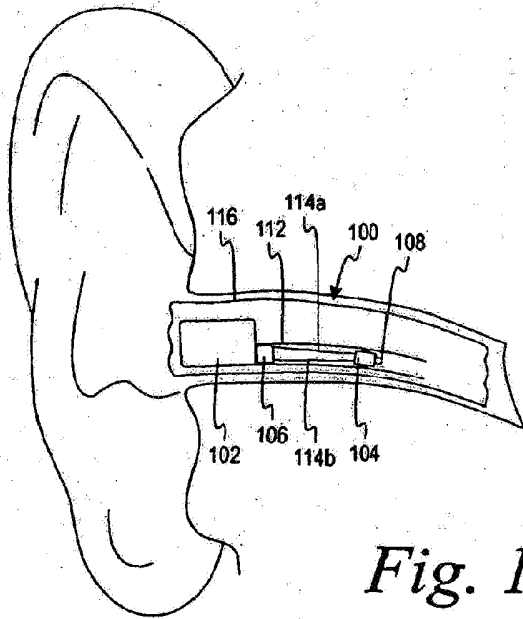

Fig. 1a

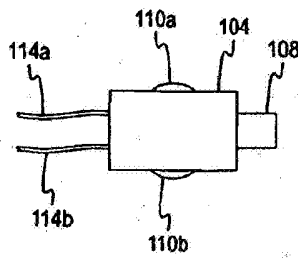

Fig. 1b

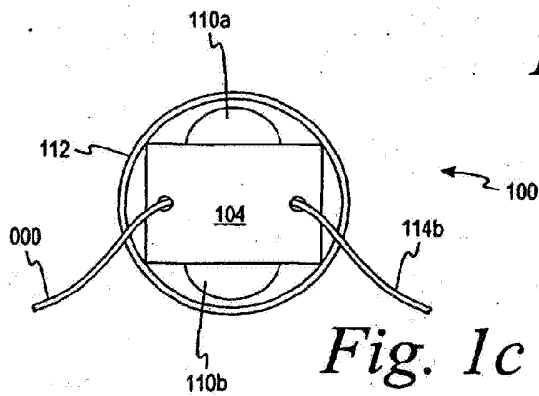

Fig. 1c

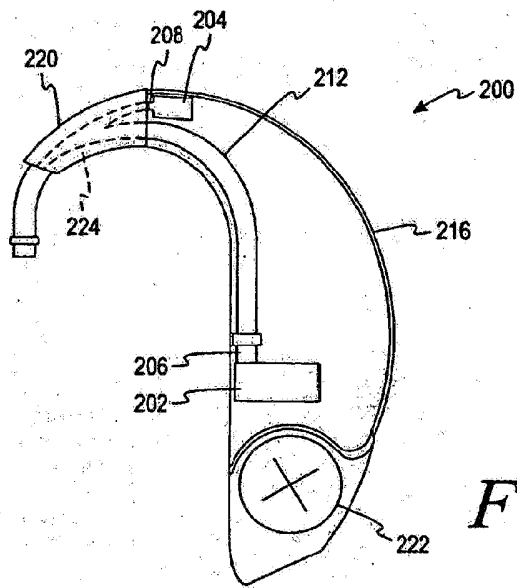

Fig. 2

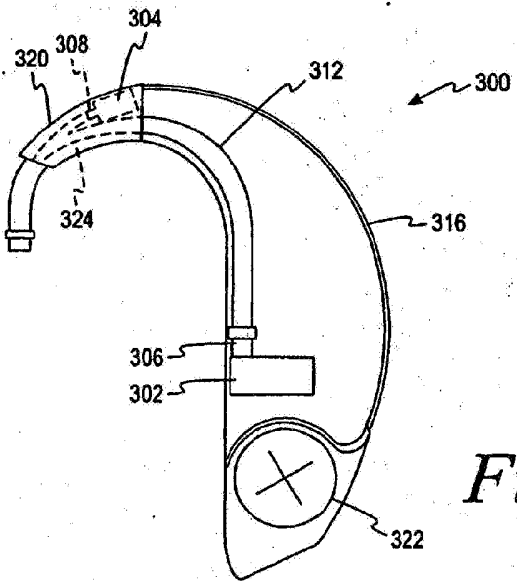
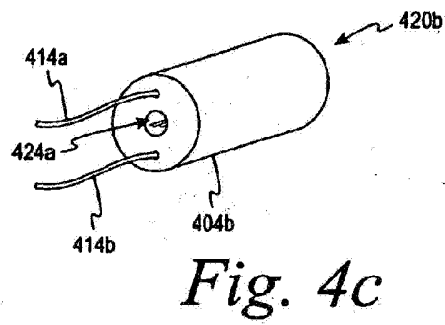
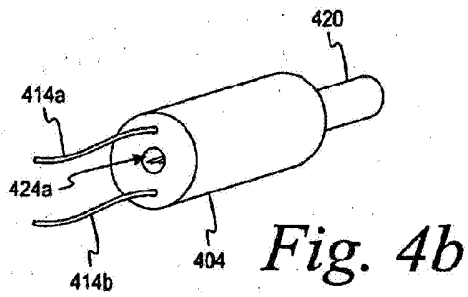
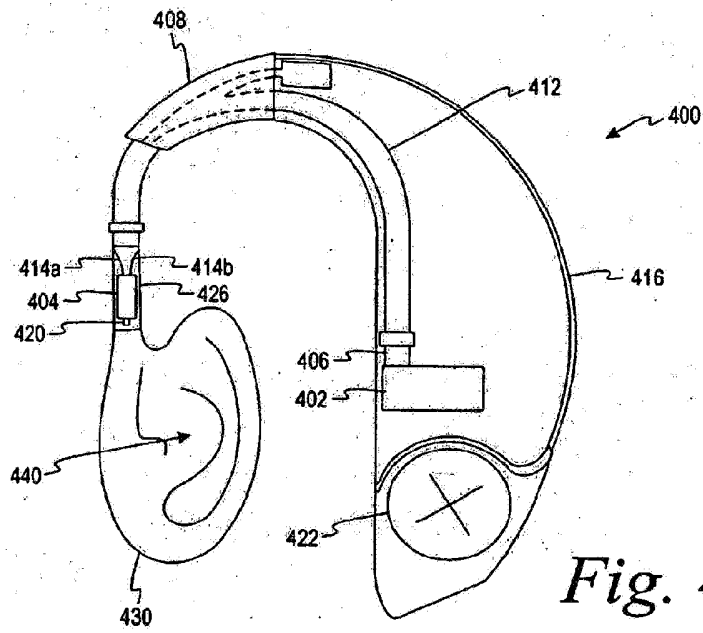

Fig. 3



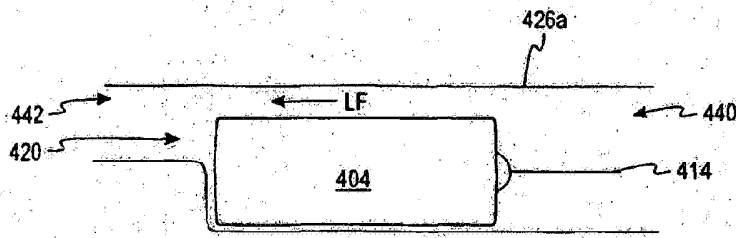

Fig. 4d

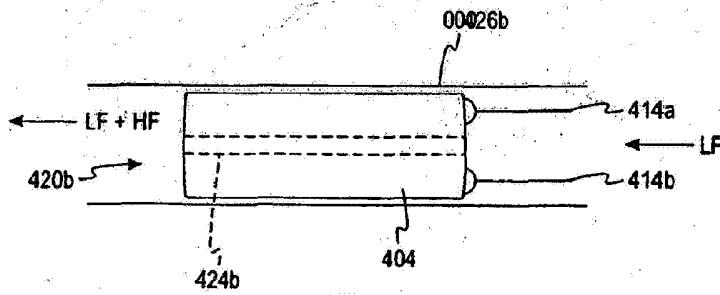

Fig. 4e

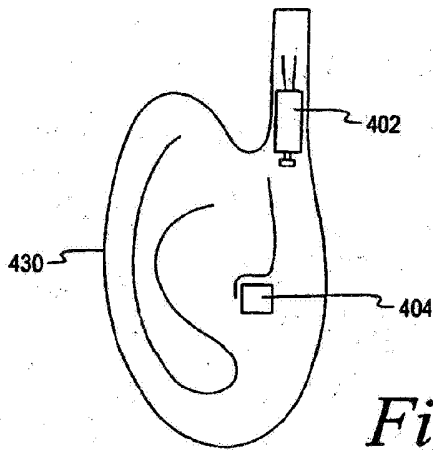
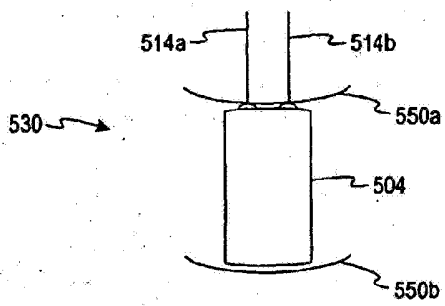
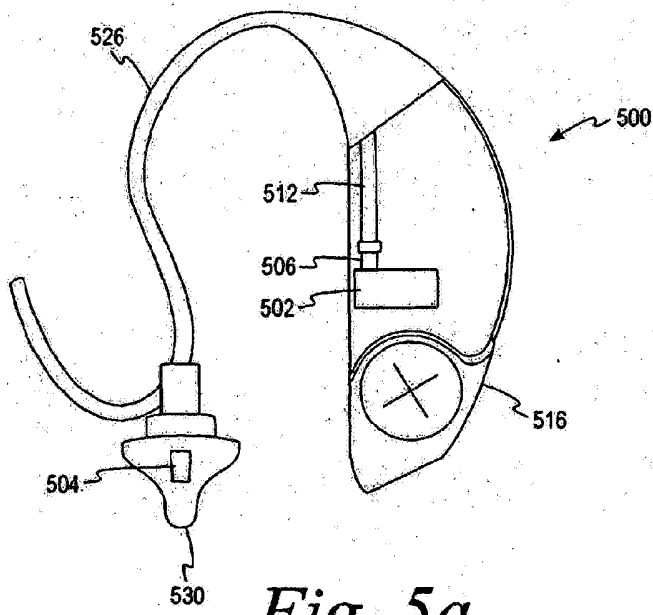

Fig. 4f



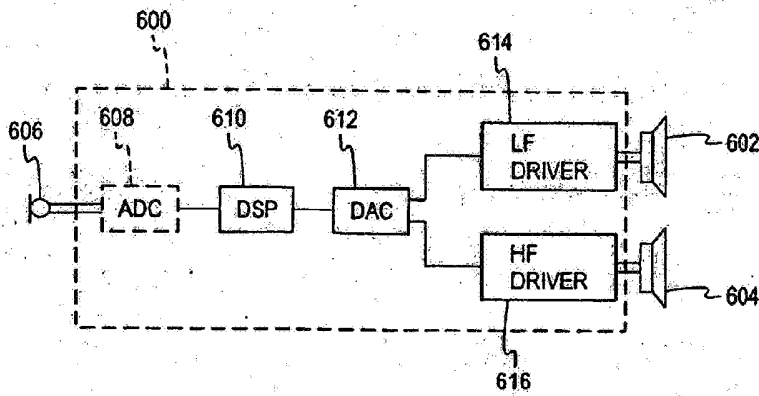

Fig. 6

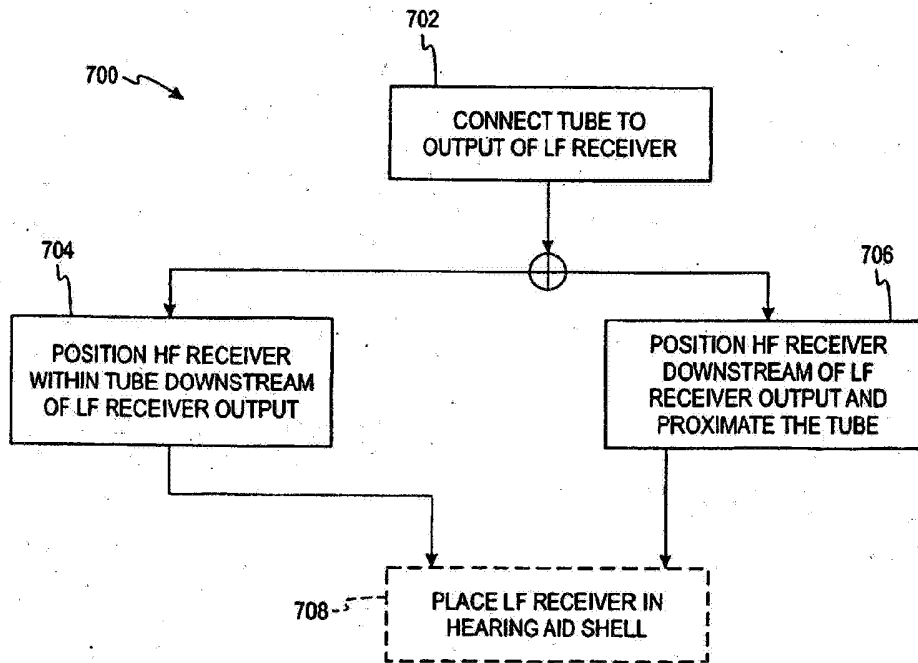

Fig. 7a