

(19) World Intellectual Property
Organization
International Bureau



(43) International Publication Date
16 December 2004 (16.12.2004)

PCT

(10) International Publication Number
WO 2004/108478 A1

- (51) International Patent Classification⁷: **B60R 7/10**
- (21) International Application Number:
PCT/US2004/012877
- (22) International Filing Date: 27 April 2004 (27.04.2004)
- (25) Filing Language: English
- (26) Publication Language: English
- (30) Priority Data:
60/474,491 30 May 2003 (30.05.2003) US
- (71) Applicant (for all designated States except US): **INTIER AUTOMOTIVE INC.** [CA/CA]; 521 Newpark Boulevard, Newmarket, Ontario L3Y 4X7 (CA).
- (72) Inventors; and
- (75) Inventors/Applicants (for US only): **KOWALSKI, Steven, M.** [US/US]; 605 East Eleven Mile Road, Apt. 3, Royal Oak, MI 48067 (US). **KRYSIK, David, J.** [US/US]; 10 Fairwood, Pleasant Ridge, MI 48069 (US).
- (74) Agents: **RASHID, Peter, J.** et al.; Honigman Miller Schwartz and Cohn LLP, 32270 Telegraph Road, Suite 225, Bingham Farms, MI 48025 (US).
- (81) Designated States (unless otherwise indicated, for every kind of national protection available): AE, AG, AL, AM, AT, AU, AZ, BA, BB, BG, BR, BW, BY, BZ, CA, CH, CN, CO, CR, CU, CZ, DE, DK, DM, DZ, EC, EE, EG, ES, FI, GB, GD, GE, GH, GM, HR, HU, ID, IL, IN, IS, JP, KE, KG, KP, KR, KZ, LC, LK, LR, LS, LT, LU, LV, MA, MD, MG, MK, MN, MW, MX, MZ, NA, NI, NO, NZ, OM, PG, PH, PL, PT, RO, RU, SC, SD, SE, SG, SK, SL, SY, TJ, TM, TN, TR, TT, TZ, UA, UG, US, UZ, VC, VN, YU, ZA, ZM, ZW.
- (84) Designated States (unless otherwise indicated, for every kind of regional protection available): ARIPO (BW, GH, GM, KE, LS, MW, MZ, NA, SD, SL, SZ, TZ, UG, ZM, ZW), Eurasian (AM, AZ, BY, KG, KZ, MD, RU, TJ, TM), European (AT, BE, BG, CH, CY, CZ, DE, DK, EE, ES, FI, FR, GB, GR, HU, IE, IT, LU, MC, NL, PL, PT, RO, SE, SI, SK, TR), OAPI (BF, BJ, CF, CG, CI, CM, GA, GN, GQ, GW, ML, MR, NE, SN, TD, TG).

Declarations under Rule 4.17:

— as to applicant's entitlement to apply for and be granted a patent (Rule 4.17(ii)) for the following designations AE, AG, AL, AM, AT, AU, AZ, BA, BB, BG, BR, BW, BY, BZ,

[Continued on next page]

(54) Title: GARMENT HOOK ASSEMBLY

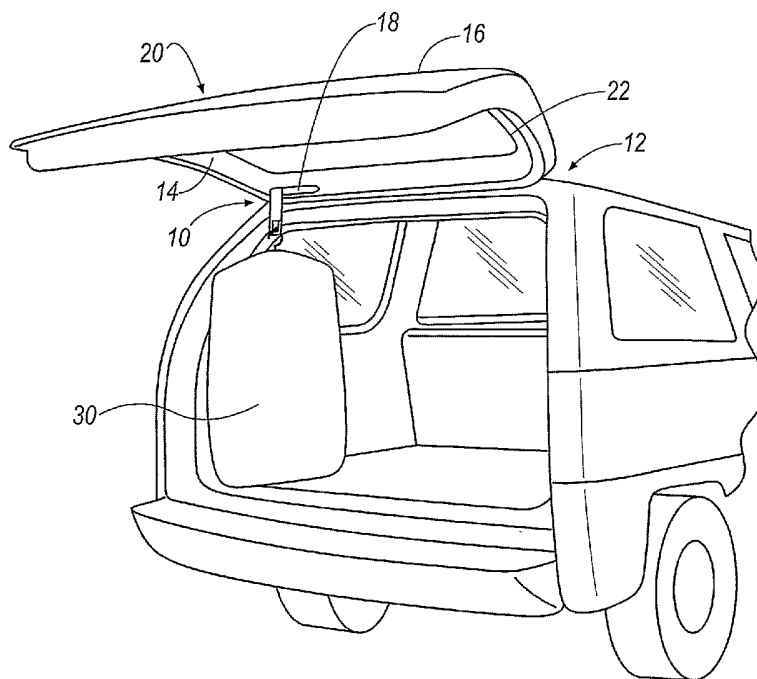

(57) Abstract: A garment hook assembly (10) comprising a hook portion (24) and a base portion (26) pivotally mounted to an inner panel (14) of a vehicle (12). The garment hook assembly (10) is automatically deployed when the inner panel (14) is moved from a raised position to a lowered position.

WO 2004/108478 A1



CA, CH, CN, CO, CR, CU, CZ, DE, DK, DM, DZ, EC, EE, EG, ES, FI, GB, GD, GE, GH, GM, HR, HU, ID, IL, IN, IS, JP, KE, KG, KP, KR, KZ, LC, LK, LR, LS, LT, LU, LV, MA, MD, MG, MK, MN, MW, MX, MZ, NA, NI, NO, NZ, OM, PG, PH, PL, PT, RO, RU, SC, SD, SE, SG, SK, SL, SY, TJ, TM, TN, TR, TT, TZ, UA, UG, UZ, VC, VN, YU, ZA, ZM, ZW, ARIPO patent (BW, GH, GM, KE, LS, MW, MZ, NA, SD, SL, SZ, TZ, UG, ZM, ZW), Eurasian patent (AM, AZ, BY, KG, KZ, MD, RU, TJ, TM), European patent (AT, BE, BG, CH, CY, CZ, DE, DK, EE, ES, FI, FR, GB, GR, HU, IE,

IT, LU, MC, NL, PL, PT, RO, SE, SI, SK, TR), OAPI patent (BF, BJ, CF, CG, CI, CM, GA, GN, GQ, GW, ML, MR, NE, SN, TD, TG)

- as to the applicant's entitlement to claim the priority of the earlier application (Rule 4.17(iii)) for all designations
- of inventorship (Rule 4.17(iv)) for US only

Published:

- with international search report

For two-letter codes and other abbreviations, refer to the "Guidance Notes on Codes and Abbreviations" appearing at the beginning of each regular issue of the PCT Gazette.

GARMENT HOOK ASSEMBLY

Technical Field

[0001] The present invention relates to an interior accessory for a vehicle and in particular to a garment hook on the rear door or liftgate of a vehicle.

Background

[0002] Typically vehicles are provided with relatively small hooks placed on either side of the headliner of the vehicle behind the front seat for receiving clothes hangers. Such hooks project from the upholstery of the headliner of the vehicle and may be unsightly. The protruding hooks may also present a safety hazard in the form of a projection against which a person may bump their head either while entering or exiting the vehicle, or in the event of an accident. Moreover, when the hooks are used, the clothes restrict the visibility of the rear windows. Furthermore, the hooks are relatively small and cannot accommodate more than a few hangers.

Summary of the Invention

[0003] The inventor of the present invention has recognized these and other problems associated with garment hooks. To this end, the inventor has developed a garment hook assembly comprising a hook portion and a base portion pivotally mounted to an inner panel of a vehicle. The garment hook assembly is automatically deployed when the inner panel is moved from a raised position to a lowered position.

Brief Description of the Drawings

[0004] The present invention will now be described, by way of example, with reference to the accompanying drawings, in which:

[0005] Figure 1 is a perspective view of the garment hook assembly in its lowered and raised position.

[0006] Figure 2 is a perspective view of the garment hook assembly in its lowered position within a sports utility vehicle.

[0007] Figure 3 is a side view of the garment hook assembly in its lowered position within a sports utility vehicle.

Description of the Preferred Embodiment

[0008] Referring to Figures 1 and 2, a garment hook assembly 10 is shown according to one embodiment of the present invention. The garment hook assembly 10 is positioned on a liftgate assembly 20 within a vehicle 12. The liftgate assembly 20 includes an inner panel 14 and an outer panel 16. The inner panel 14 of the liftgate assembly 20 has a recess 18 for housing the garment hook assembly 10.

[0009] As best seen in Figure 1, the garment hook assembly 10 comprises a hook portion 24 and a base portion 26. The hook portion 24 and the base portion 26 are located on opposite ends of the garment hook assembly 10. In the illustrated embodiment of the present invention, the hook portion 24 can be made from a metal material and the base portion 26 can be made from a plastic material. However, it can be appreciated that the garment hook assembly 10 can also be made of all metal or all plastic, depending on the desired objectives. For instance, an all plastic garment hook assembly 10 has the advantages of being a lighter weight than an all metal garment hook assembly 10. In addition, an all plastic garment hook assembly 10 may be manufactured simultaneously with the inner panel 14 of the liftgate assembly 20 in an injection molding process, resulting in lower manufacturing and assembly costs. On the other hand, an all metal garment hook assembly 10 has the advantage of being able to support a greater weight than an all plastic hook.

[0010] In one embodiment of the present invention, the base portion 26 of the garment hook assembly 10 is secured to the sheet metal of the vehicle (not shown). The base portion 26 may pass through the inner panel 14 of the liftgate assembly 20 and attach directly to the sheet metal of the vehicle 12 by any conventional method. In one example of a conventional method for attachment, the base portion 26 of the garment hook assembly 10 snap fits into an aperture (not shown) in the sheet metal of the vehicle 12. By directly attaching the base portion 26 of the garment hook assembly 10 to the sheet metal

of the vehicle 12, the garment hook assembly 10 has enough support to hold a substantially greater amount of weight than conventional garment hooks.

[0011] Alternatively, the garment hook assembly 10 may be attached directly to the inner panel 14 of the liftgate assembly 20. If the garment hook assembly 10 is attached to the inner panel 14 of the liftgate assembly 20, the garment hook assembly 10 may be injection molded simultaneously with the inner panel 14 of the liftgate assembly or may be manufactured separately and attached as a secondary process. As with a metal base portion 26, a plastic base portion 26 of the garment hook assembly 10 may be secured to the inner panel 14 by snap fitting the plastic base portion 26 into an aperture in the inner panel 14 of the liftgate assembly 20.

[0012] In another embodiment of the present invention, the hook portion 24 of the garment hook assembly 10 extends to the sheet metal and directly attaches to the sheet metal of the vehicle 12. The base portion 26 of the garment hook assembly 10 acts as a cover over the hook portion 24, covering the bottom segment of the hook portion 24. The inner panel 14 of the liftgate assembly 20 has an aperture (not shown) for the hook portion 24 of the garment hook assembly 10 to pass through. The hook portion 24 may also pass through the base portion 26 if the base portion 26 is integral with the inner panel 14 of the liftgate assembly 20. If the base portion 26 is separate from the inner panel 14, the base portion 26 is placed over the bottom segment of the hook portion 24 and attached to the inner panel 14 of the liftgate assembly 20.

[0013] The base portion 26 of the garment hook assembly 10 is pivotally attached to the vehicle 12. In the illustrated embodiment, the garment hook assembly 10 is pivotally attached within the recess 18 of the inner panel 14 of the vehicle 12. The pivotal attachment allows for the base portion 26 of the garment hook assembly 10 to automatically rotate between a raised position, as shown in phantom in Figure 1, and a lowered position, shown in solid in Figure 1. The garment hook assembly 10 automatically rotates from the raised position to the lowered position when the liftgate assembly 20 is opened, as shown in Figure 2.

[0014] When the garment hook assembly 10 is in the raised position, the garment hook assembly 10 rests within the recess 18 of the inner panel 14. The recess 18 has a shape that

substantially corresponds to the shape of the garment hook assembly 10. The depth of the recess 18 is such that when the garment hook assembly 10 is raised, the garment hook assembly 10, with or without garments 30, is substantially flush with the inner panel 14 of the liftgate assembly 20. When the garment hook assembly 10 is in the lowered position, the hook portion 26 is accessible for hanging garments 30. Upon closing of the liftgate assembly 20, the garments 30 will be positioned completely within the vehicle 12, as best seen in Figure 3.

[0015] One aspect of the present invention is the automatic movement of the garment hook assembly 10 as the liftgate assembly 20 is opened and closed. The garment hook assembly 10 is pivoted within the recess 18 of the inner panel 14 such that the garment hook assembly 10 will automatically deploy to the lowered position upon opening of the liftgate assembly 20 and return to the raised position upon closing of the liftgate assembly 20. Therefore, the garment hook assembly 10 is visible and easily accessible when the liftgate assembly 20 is opened and will not obstruct the view of the driver when the liftgate assembly 20 is closed. In the illustrated embodiment of the present invention, the garment hook assembly 10 is pivotally attached at the left side of the recess 18. However, it can be appreciated that the garment hook assembly 10 can be positioned anywhere within recess 18 so long as the garment hook assembly 10 will automatically deploy to the lowered position upon opening of the liftgate assembly 20 and automatically return to the raised position upon closing of the liftgate assembly 20.

[0016] The garment hook assembly 10 of the present invention has many advantages over conventional garment hooks. For example, the garment hook assembly 10 can hold more garments, or a greater weight of garments, than conventional garment hooks. The hook portion 24 of the garment hook assembly 10 is easily accessible. In addition, a person standing outside the vehicle 12 is able to visually see the garment hook assembly 10. By contrast, conventional garment hooks are hidden to someone standing outside of the vehicle 12. Once the garments are secured by the garment hook assembly 10 and the liftgate assembly 20 is closed, the garments remain flush against the side of the vehicle 12 so the driver's field of view is not compromised.

[0017] In the illustrated embodiment, the garment hook assembly 10 is mounted to the liftgate assembly 20 for automatic deployment. However, it will be appreciated that the

garment hook assembly 10 can be mounted to any location within the interior of the vehicle that will allow the automatic deployment of the garment hook assembly 10, such as a door, or the like. It can also be appreciated that the present invention may be practiced in any type of vehicle closure. For instance, the garment hook assembly 10 can be positioned on a front or rear door of the vehicle. Additionally, the size of the garment hook assembly 10 can vary depending on the desired objectives. A large garment hook assembly 10 may be desired if it is anticipated that the garment hook assembly 10 will be utilized for garments 30 that are heavy. In contrast, a small garment hook assembly 10 may be desired if it is anticipated that the garments 30 will be light in weight, or if there is limited space available in the vehicle, thereby limiting the amount of garments 30. Furthermore, the number of garment hook assemblies 10 can vary per vehicle 12. For example, a sedan may have two garment hook assemblies 10; one above the driver's side rear door and one above the passenger's side rear door. A SUV, for example, may have three or more garment hook assemblies 20; two small garment hook assemblies 20 above the rear doors and one or more large garment hook assemblies 20 on the liftgate 10 of the vehicle 12.

[0018] It should be understood that the aforementioned and other various alternatives to the embodiments of the invention described herein may be employed in practicing the invention. It is intended that the following claims define the scope of the invention and that the method and apparatus within the scope of these claims and their equivalents be covered thereby.

Claims

What is claimed is:

1. A garment hook assembly (10) comprising:
a hook portion (24) ; and
a base portion (26) pivotally mounted to an inner panel (14) of a vehicle (12);
wherein the garment hook assembly (10) is automatically deployed when the inner panel (14) is moved from a raised position to a lowered position.
2. A garment hook assembly (10) according to Claim 1, wherein the inner panel (14) is a liftgate assembly (20) of the vehicle (12).
3. A garment hook assembly (10) according to Claim 1, wherein the hook portion (24) is capable of holding an object (30) when the garment hook assembly (10) is in the lowered position.
4. A garment hook assembly according to Claim 1, wherein the hook portion (24) is made from a metal material.
5. A garment hook assembly according to Claim 1, wherein the hook portion (24) is made from a plastic material.
6. A garment hook assembly according to Claim 1, wherein the base portion (26) is made from a metal material.
7. A garment hook assembly according to Claim 1, wherein the base portion (26) is made from a plastic material.
8. A garment hook assembly comprising:
a hook (24) pivotally mounted to a surface (14);
a base (26), wherein the base (26) acts as a cover over the hook (24);

wherein said hook (24) is automatically deployed when the surface (14) is moved from a first position to a second position.

9. A garment hook assembly (10) according to Claim 8, wherein the hook (14) is capable of holding an object (30) when the hook (14) is in the second position.

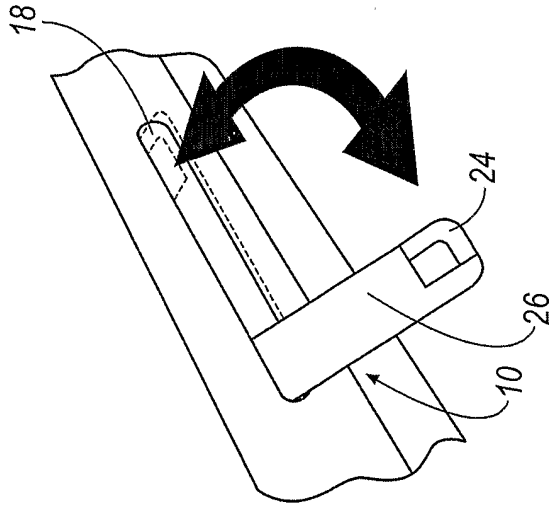

FIG. 1

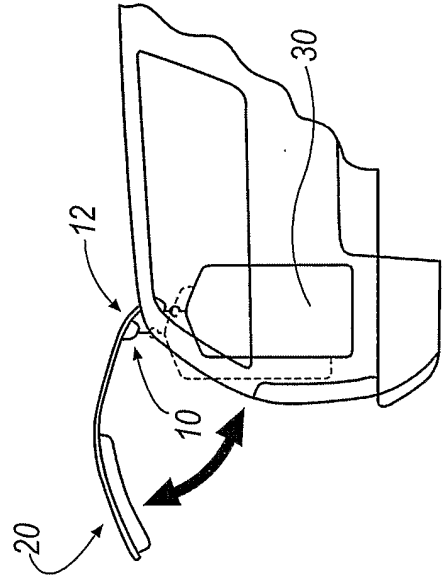

FIG. 3

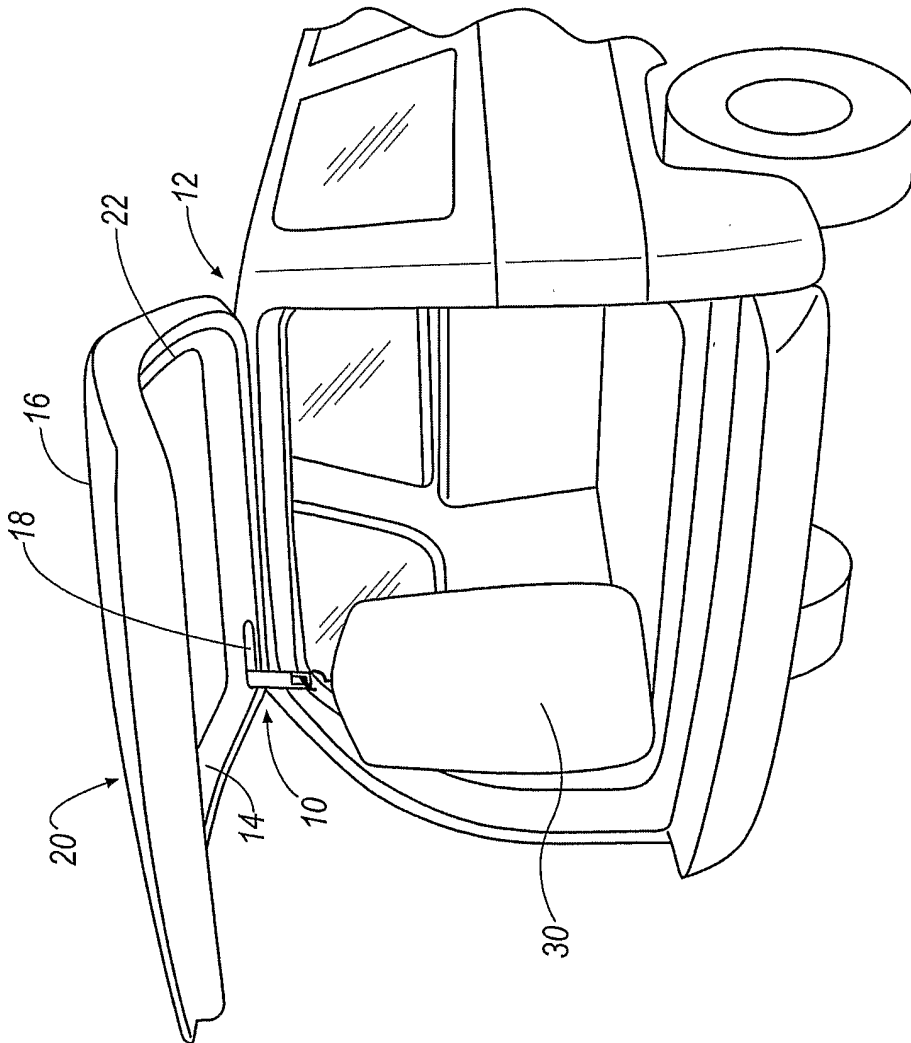

FIG. 2

INTERNATIONAL SEARCH REPORT

International Application No
PCT/US2004/012877

A. CLASSIFICATION OF SUBJECT MATTER
IPC 7 B60R7/10

According to International Patent Classification (IPC) or to both national classification and IPC

B. FIELDS SEARCHED

Minimum documentation searched (classification system followed by classification symbols)
IPC 7 B60R A47G B60J

Documentation searched other than minimum documentation to the extent that such documents are included in the fields searched

Electronic data base consulted during the international search (name of data base and, where practical, search terms used)

EPO-Internal, WPI Data, PAJ

C. DOCUMENTS CONSIDERED TO BE RELEVANT

Category °	Citation of document, with indication, where appropriate, of the relevant passages	Relevant to claim No.
X	US 6 109 579 A (HUANG HAN-CHING) 29 August 2000 (2000-08-29)	1,3,8,9
Y	the whole document	2,4-7
Y	----- US 6 502 731 B1 (HAVIDIC DEJAN ET AL) 7 January 2003 (2003-01-07)	2,4-7
	the whole document	
X	----- GB 1 052 859 A (ANDRE GILLET) 30 December 1966 (1966-12-30)	1,3,8,9
	the whole document	
A	----- US 4 671 556 A (LYNAS III WILLIAM P) 9 June 1987 (1987-06-09)	
A	----- DE 44 40 520 C (HUELSTA WERKE HUELS KG) 14 March 1996 (1996-03-14)	

Further documents are listed in the continuation of box C. Patent family members are listed in annex.

° Special categories of cited documents :

<p>*A* document defining the general state of the art which is not considered to be of particular relevance</p> <p>*E* earlier document but published on or after the international filing date</p> <p>*L* document which may throw doubts on priority claim(s) or which is cited to establish the publication date of another citation or other special reason (as specified)</p> <p>*O* document referring to an oral disclosure, use, exhibition or other means</p> <p>*P* document published prior to the international filing date but later than the priority date claimed</p>	<p>*T* later document published after the international filing date or priority date and not in conflict with the application but cited to understand the principle or theory underlying the invention</p> <p>*X* document of particular relevance; the claimed invention cannot be considered novel or cannot be considered to involve an inventive step when the document is taken alone</p> <p>*Y* document of particular relevance; the claimed invention cannot be considered to involve an inventive step when the document is combined with one or more other such documents, such combination being obvious to a person skilled in the art.</p> <p>*&* document member of the same patent family</p>
--	--

Date of the actual completion of the international search	Date of mailing of the international search report
11 August 2004	25/08/2004

Name and mailing address of the ISA European Patent Office, P.B. 5818 Patentlaan 2 NL - 2280 HV Rijswijk Tel. (+31-70) 340-2040, Tx. 31 651 epo nl, Fax: (+31-70) 340-3016	Authorized officer Busuiocescu, B
--	--

INTERNATIONAL SEARCH REPORT

Information on patent family members

International Application No

PCT/US2004/012877

Patent document cited in search report	Publication date	Patent family member(s)	Publication date
US 6109579	A	29-08-2000	NONE
US 6502731	B1	07-01-2003	EP 1419066 A1 19-05-2004 WO 03013909 A1 20-02-2003
GB 1052859	A		NONE
US 4671556	A	09-06-1987	AU 6840587 A 15-07-1987 CA 1273612 A1 04-09-1990 EP 0258278 A1 09-03-1988 WO 8703848 A1 02-07-1987
DE 4440520	C	14-03-1996	DE 4440520 C1 14-03-1996