

(19) World Intellectual Property Organization  
International Bureau



(43) International Publication Date  
5 November 2009 (05.11.2009)

(10) International Publication Number  
**WO 2009/135128 A2**

- (51) **International Patent Classification:**  
*B65D 5/20* (2006.01)
- (21) **International Application Number:**  
PCT/US2009/042527
- (22) **International Filing Date:**  
1 May 2009 (01.05.2009)
- (25) **Filing Language:** English
- (26) **Publication Language:** English
- (30) **Priority Data:**  
61/049,546 1 May 2008 (01.05.2008) US
- (71) **Applicant (for all designated States except US):** MEAD-WESTVACO CORPORATION [US/US]; 11013 West Broad Street, Glen Allen, VA 23060 (US).
- (72) **Inventors; and**
- (75) **Inventors/Applicants (for US only):** JONES, Steve [US/US]; 902 Pagetown Road, Elon, NC 27244 (US). JONES, Marty [US/US]; 424 Green Street, Graham, NC 27253 (US). WORKMAN, Robert [US/US]; 7411 Oakwood Street, Mebane, NC 27302 (US).
- (74) **Agents:** SCHEIDLER, Alison et al.; Meadwestvaco Corporation, 1021 Main Campus Drive, Raleigh, NC 27606 (US).

(81) **Designated States (unless otherwise indicated, for every kind of national protection available):** AE, AG, AL, AM, AO, AT, AU, AZ, BA, BB, BG, BH, BR, BW, BY, BZ, CA, CH, CN, CO, CR, CU, CZ, DE, DK, DM, DO, DZ, EC, EE, EG, ES, FI, GB, GD, GE, GH, GM, GT, HN, HR, HU, ID, IL, IN, IS, JP, KE, KG, KM, KN, KP, KR, KZ, LA, LC, LK, LR, LS, LT, LU, LY, MA, MD, ME, MG, MK, MN, MW, MX, MY, MZ, NA, NG, NI, NO, NZ, OM, PG, PH, PL, PT, RO, RS, RU, SC, SD, SE, SG, SK, SL, SM, ST, SV, SY, TJ, TM, TN, TR, TT, TZ, UA, UG, US, UZ, VC, VN, ZA, ZM, ZW.

(84) **Designated States (unless otherwise indicated, for every kind of regional protection available):** ARIPO (BW, GH, GM, KE, LS, MW, MZ, NA, SD, SL, SZ, TZ, UG, ZM, ZW), Eurasian (AM, AZ, BY, KG, KZ, MD, RU, TJ, TM), European (AT, BE, BG, CH, CY, CZ, DE, DK, EE, ES, FI, FR, GB, GR, HR, HU, IE, IS, IT, LT, LU, LV, MC, MK, MT, NL, NO, PL, PT, RO, SE, SI, SK, TR), OAPI (BF, BJ, CF, CG, CI, CM, GA, GN, GQ, GW, ML, MR, NE, SN, TD, TG).

**Published:**

— without international search report and to be republished upon receipt of that report (Rule 48.2(g))

(54) **Title:** DUAL PACKAGING SYSTEM WITH CHILD RESISTANCE AND SENIOR FRIENDLY FEATURES

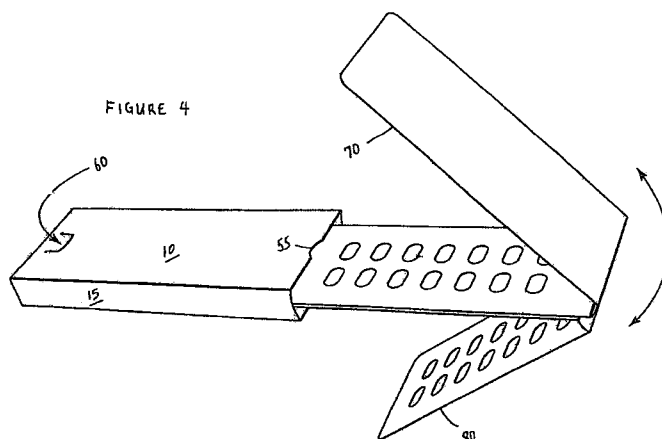

(57) **Abstract:** A two-piece package for housing and dispensing a unit dose product. The product to be dispensed is contained on an internal slide card that is removably and lockably engaged within an outer sleeve. The package provides a child resistant and user-friendly dosing means that can be opened and closed numerous times while in use, then disposed of when all the unit doses are exhausted.



WO 2009/135128 A2

## SUMMARY OF THE INVENTION

[0001] A dual dose package according to the embodiments of the invention is composed of a pair of internal slide cards and an outer sleeve. The outer sleeve and the internal slide cards may be cut from any suitable material, for example plastic, paperboard or, if desired a laminate of paperboard and another foldable material, for example a foil or a polymeric film. The selection of this substrate may be made according to the packaging need, and accordingly, a substrate material generally recognized as safe (GRAS) by the FDA is also within the scope of the invention. In certain embodiments, the substrate may be selected from a sheet of bleached sulfate board, solid unbleached sulfate board (SUS), clay-coated newsback (CCNB), or any other suitable board substrate, such a substrate preferably ranging in thickness from about 0.008 inches up to about 0.050 inches. For example, the paperboard may be clay coated on one side (C1S) or on both sides (C2S), with a coating such as a fluidized blend of mineral pigments selected from coating clay, calcium carbonate and/or titanium dioxide with starch or adhesive, or various combinations of these materials. Successive densification and polishing (via calendering) finishes each coated surface to a high degree of smoothness and renders it suitable for graphics printing of superior quality.

[0002] In a first embodiment, the outer sleeve includes a pair of side panels and an inner partition panel forming the wider surfaces of the package, these side panels and the inner partition panel being operatively connected by a plurality of hinge panels. The design of the outer sleeve creates two chambers that can each accommodate a separate inner slide card. Each of the side panels includes a slide card locking mechanism, while a pair of extension panels that provide for a false bottom to the outer sleeve include a releasing mechanism. The slide

card locking mechanism can be in the form of a release button located in the side panels, while the slide card locking means can be composed of a cut away region that includes a node for engaging an extension of the internal slide card in the extension panel.

[0003] Depending on the choice of substrate material, another means of improving the impenetrability of the sleeve involves lamination of at least a part of one or both sides of the blank with a polymer film. In this manner, the exterior of the package is made more resistant to tearing. Optionally, this lamination may not extend over the entire surface of the sleeve blank. For example, only tear prone regions may require lamination. Suitable laminating materials may, for example, be selected from biaxially oriented or cross-laminated polymeric films such as high density polyethylene (HDPE), polyolefins, polyesters, e.g. Mylar.TM., or combinations thereof. In a related embodiment, tear resistance may be provided at stress points such as the package corners and exposed edges by applying one or more strips of the polymeric film, e.g. as a tape, over these areas. In either aspect, the polymeric film may be applied by extrusion or adhesive lamination, or by any other suitable means known in the art, typically to the side that is the interior surface of the blank. It has been found that this treatment significantly increases tear resistance and prevents tear propagation in the outer sleeve. Preferably, neither the complete laminate film nor the selectively applied film strips will detract from the package's aesthetic appearance or interfere with printability or any of the other desirable display features. Text or graphic information may be printed on the sleeve or on the surfaces of the internal slide card according to any means conventionally known in the art.

[0004] The outer sleeve of the package provides additional protection for the internal slide cards, which houses the unit dose product being used. The internal slide cards include a stop

feature, typically a folded extension thereof, that engages with a catch feature, typically also a folded extension, on the outer sleeve, to prevent the user from pulling the internal slide cards completely away from the outer sleeve.

[0005] Optionally, other means for improving the structural integrity of the overall package may be incorporated. Such features include lamination of the slide card with a polymeric film, as described above, which also improves tear resistance.

#### BRIEF DESCRIPTION OF THE DRAWINGS

[0006] Figure 1 is a plan drawing of an outer sleeve according to a first embodiment.

[0007] Figure 2 is a first isometric view of a package according to the first embodiment.

[0008] Figure 3 is a second isometric view of a package according to the first embodiment.

[0009] Figure 4 is a third isometric view of a package according to the first embodiment.

[0010] Figure 5 is a plan drawing of an outer sleeve according to a second embodiment.

[0011] Figure 6 is a first isometric view of a package according to the second embodiment.

[0012] Figure 7 is a second isometric view of a package according to the second embodiment.

[0013] Figure 8 is a third isometric view of a package according to the second embodiment.

#### DETAILED DESCRIPTION OF THE PREFERRED EMBODIMENTS OF THE INVENTION

[0014] The embodiments shown and described herein offer the ability to include multiple internal slide cards that contain the unit doses into a single packaging solution. This type of packaging increases the number of unit doses that can be included in a packaging solution and

maintains the child safety and senior friendly aspects while significantly reducing the materials required to package the unit doses.

[0015] Figure 1 is a plan drawing of an outer sleeve according to a first embodiment. An outer sleeve is formed from a blank 100 that is scored to form a pair of side panels 10, 20, an inner partition panel 30, a pair of hinge panels 15, a pair of inner partition hinge panels 25, a first pair of scored extension panels 35, and a second pair of extension panels 40.

[0016] To form the outer sleeve, one of the inner partition hinge panels 25 is folded at a right angle to side panel 20. The inner partition panel 30 is then folded at a right angle to the folded inner partition hinge panel 25 such that inner partition panel 30 is parallel to and beneath side panel 20. The other inner partition hinge panel 25 is then folded at a right angle downward from the inner partition panel 30. Next, the hinge panel 15 that is coupled with both side panels 10, 20 is folded at a right angle downward. This hinge panel 15 is approximately twice the width of the inner partition hinge panel 25. Thus, it extends downward such that the inner partition panel intersects the hinge panel 15 perpendicularly about midway its width. Side panel 10 is then folded at a right angle such that it is now parallel to and beneath inner partition panel 30 and side panel 20. The other hinge panel 15 is then folded at a right angle upwards and can be secured (e.g., using an adhesive) against the opposite edge of side panel 20 so that it completes a three dimensional rectangular box.

[0017] The first pair of scored extension panels 35 each extend from one end of side panels 10 and 20 respectively. These scored extension panels 35 further include locking mechanisms that are designed to maintain a slide card insert firmly in place. The locking mechanism is comprised of a cut-away area 45 in the extension panel 35 having a node 50. The scored extension panels

35 are folded along the score lines and inserted and secured within respective chambers defined by outer sleeve progression of side panel 10, inner partition panel 30, and side panel 20. Upon insertion, the scored extension panels form a bottom for the overall package. The locking mechanisms (cut-away area 45 and node 50) are now within a defined chamber and can operatively couple with a slide card insert when one is inserted into the chamber.

[0018] The second pair of extension panels 40 each extend from the opposite end of side panels 10 and 20 respectively. These extension panels 40 further include a cut out notch 55. These extension panels 40 are folded beneath and tucked into the openings of the chambers defined by the side panels 10, 20 and inner partition panel 30. These extension panels 40 are not sealed to any particular surface within the chamber. The cut out notch 55 is essentially circular wherein half of the circle resides on the side panel 10, 20 and the other half resides on the extension panel 40. When the extension panels 40 are folded into the chamber opening the notch 55 becomes a semi-circular cut-out that exposes the slide card insert enough that a user can grasp and pull the slide card insert out from the sleeve. The main purpose of these extension panels 40 is to serve as a retaining element for a slide card insert. When a slide card insert is pulled outward, it will extend until a reciprocal element on the slide card insert engages the extension panel 40.

[0019] Each side panel 10, 20 further includes a release mechanism in the form of a release button 60. To release a slide card insert so that it can be withdrawn from its chamber within the outer sleeve, the user simultaneously grasps the slide card insert with one hand via notch 55 and depresses the release button 60 with his other hand. The release button 60 pushes

downward on the slide card insert to unhook it from the locking mechanism 45, 50 situated on extension panel 35.

[0020] While not shown, the open end of the defined chambers can be temporarily sealed such that the seal must be removed before a slide card can be accessed. This would prevent access to the slide card contents prior to purchase for certain over-the-counter (OTC) products that utilize this packaging. The end can be sealed with, for instance, a tuck closure, a perforated tear-away panel, a security taped panel, etc.

[0021] Figure 2 is a first isometric view of a package according to the first embodiment. This figure shows the outer sleeve fully formed and containing a pair of internal slide cards 70, 80. The release button 60 and notch 55 are visible on side panel 10.

[0022] Figure 3 is a second isometric view of a package according to the first embodiment. This view is similar to Figure 2 but further shows the internal slide cards 70, 80 partially removed from the outer sleeve.

[0023] Figure 4 is a third isometric view of a package according to the first embodiment. This view is similar to Figures 2 and 3. This time the internal slide cards 70, 80 are shown fully removed from the outer sleeve such that the individual doses stored on the internal slide cards are exposed and accessible.

[0024] Figure 5 is a plan drawing of an outer sleeve according to a second embodiment. In this embodiment, two separate outer sleeve packages are joined together along a common hinge line 570. The outer sleeves are formed from a blank 500 that is scored to form six panels. Each outer sleeve includes three of the panels separated by a common hinge such that one set of three panels is an inverted mirror image of the other set of three panels. To form one of the

outer sleeves, a first panel 510A is folded beneath and secured, for example using an adhesive, beneath a second panel 530A, such that panel 510A is positioned within the interior of the formed outer sleeve. The side panels 510A, 520A, 530A are each separated by a set of hinge panels 515A. The hinge panels 515A provide a depth element to the outer sleeve and create an inner chamber adapted to receive and house an inner slide card containing unit doses.

[0025] The panel 510A includes a panel extension 525A, which acts as a stopping device that prevents an internal slide card from being withdrawn completely from the outer sleeve. A third panel 520A includes an additional extension 540A, which may be folded toward the center of panel 520A to form a bottom that strengthens the package and thus renders it more tamper resistant. Extension panel 545A will overlap and be secured to extension panel 540A to complete the bottom of the outer sleeve packaging. Panel 510A additionally includes a cut away area 560A having a node 555A. The cut away area 560A, node 555A, and a release button 565A, and an extension panel 525A together form the locking assembly for the package. The locking mechanism operates similarly to that described in U.S. Pat. No. 6,047,829, herein incorporated by reference. The blank 500 also includes a cutaway area 550A, which, when folded together, form a notch that is paired with notch 552A.

[0026] The opposite side panels 510B, 520B, 530B as well as hinge panels 515B are folded in the same fashion as described above to form the second outer sleeve. Once folded, there will be two separate outer sleeve units that are inseparably joined along a common hinge line 570. Each outer sleeve is capable of housing an internal slide card.

[0027] The locking mechanisms 555A, 560A, 555B, 560B operate in conjunction with release buttons 565A, 565B as described above with respect to Figures 1 -4. Similarly, extension panels

535A, 535B serve to retain the internal slide cards from being completely extracted from within the chambers defined by the outer sleeves.

[0028] Figure 6 is a first isometric view of a package according to the second embodiment. This view shows both outer sleeves joined at a common hinge line partially separated from one another. On the upper outer sleeve, side panel 530A is visible and includes release button 565A and notch 552A. One of the hinge panels 515A as well as extension panel 545A that forms a bottom are also visible. On the lower outer sleeve, side panel 520B, hinge panel 515B, and notch 552B are visible.

[0029] Figure 7 is a second isometric view of a package according to the second embodiment. This view shows both outer sleeves joined at a common hinge line 570 with no separation from one another. On the upper outer sleeve, side panel 530A is visible and includes release button 565A and notch 552A. One of the hinge panels 515A is also visible. On the lower outer sleeve, hinge panel 515B, and as well as extension panel 545B that forms a bottom are visible.

[0030] Figure 8 is a third isometric view of a package according to the second embodiment. Figure 8 is the same as Figure 7 but it also illustrates the internal slide cards 580A, 580B withdrawn from the outer sleeve chambers to the extent that the unit doses contained on the internal slide cards 580A, 580B are exposed and accessible.

[0031] The description above has made reference to slide cards that can be inserted and withdrawn from the packaging. The slide cards generally hold a plurality of unit doses contained within what is commonly referred to as blister packs. Thus, the slide cards may take the form of solely a blister pack, a blister pack heat sealed to a substrate, a blister pack glued (e.g., hot melted) to a substrate, or a blister pack encased by a slotted substrate.

[0032] The package of the present invention offers advantages in that it can accommodate two blister pack containing internal slide cards, is lightweight, tamper resistant, senior friendly, durable, easy to assemble, offers protection of each unit dose until it is consumed, and is economical. Moreover, the invention provides a child resistant yet user-friendly unit dose packaging container, which may be used to contain and dispense a variety of contents. The improved tamper resistant features of the package may be attributed, at least in part, to the presence of the false bottom structural support, the offset notch placement and the use of partially or fully laminated structural materials in construction of the package sleeve and slide card. Suitably, the package may, for example, be used to store pharmaceutical preparations requiring repeat periodic dosage regimens. As used herein, the term "pharmaceutical preparation" is intended to include prescribed or over the counter drugs or supplements, vitamins or other medicaments, or any other materials suitable for containment in a package of foil/paperboard or plastic construction.

[0033] It is believed that the present invention includes many other embodiments that may not be herein described in detail, but would nonetheless be appreciated by those skilled in the art from the disclosures made. Accordingly, this disclosure should not be read as being limited only to the foregoing examples or only to the designated preferred embodiments.

We claim:

1. A packaging system comprising:

an outer sleeve comprised of a pair of side panels, an inner partition panel, a plurality of hinge panels, said side panels, inner partition panel, and hinge panels being operatively connected with each other such that the inner partition panel is disposed between the pair of side panels to define two separate inner chambers capable of receiving and housing an internal slide card,

wherein each side panel includes:

a first foldable extension at one end of the side panel thereof, said extension including a slide card locking mechanism, said extension being folded toward the interior of the sleeve to form a packaging bottom;

a second foldable extension at the other end of the side panel thereof, said extension being folded toward the interior of the sleeve to form an internal slide card retaining element; and

a release button positioned proximate to the slide card locking mechanism.

2. The packaging system of claim 1 wherein the outer sleeve further includes a pair of notches for grasping and removing an internal slide card.

3. The packaging system of claim 1 wherein the outer sleeve is at least partially laminated with a polymeric film material.

4. The packaging system of claim 3 wherein the polymeric film material is laminated over an entire surface of the outer sleeve.
5. The packaging system of claim 1 wherein the outer sleeve is constructed from a paperboard or plastic substrate.
6. The packaging system of claim 1 wherein the internal slide card is comprised of one or more of a blister pack, a blister pack heat sealed to a substrate, a blister pack glued (e.g., hot melted) to a substrate, or a blister pack encased by a slotted substrate.
7. The packaging system of claim 1 wherein a receiving end of the outer sleeve includes a temporary seal comprised of one of a tuck closure, a perforated tear-away panel, and a security taped panel that can be removed to provide access to the internal slide card housed within.
8. A blank for forming a lockable outer sleeve for housing at least one internal slide card of a packaging system comprising:
  - a pair of side panels; and
  - a plurality of hinge panels,wherein each side panel includes:
  - a first foldable extension at one end of the side panel thereof, said extension including a slide card locking mechanism;

a second foldable extension at the other end of the side panel thereof, said extension being folded toward the interior of the sleeve to form an internal slide card retaining element; and

a releasing mechanism positioned proximate to the slide card locking mechanism.

9. The blank of claim 8 wherein the slide card locking mechanism is in the form of a cutaway located in each side panel.

10. The blank of claim 9 wherein the cutaway additionally includes a node for engagement of an edge of an internal slide card.

11. The blank of claim 8 wherein the releasing mechanism is in the form of a release button located in each side panel.

12. The blank of claim 8 further including a polymeric film material laminated over at least a portion of one or both surfaces thereof.

13. A packaging system comprising:

a pair of outer sleeves joined at a common hinge panel edge such that the packaging system can receive and house an internal slide card in each outer sleeve wherein each outer sleeve is comprised of:

a plurality of side panels, a plurality of hinge panels, said side panels and hinge panels being operatively connected with each other wherein,

at least one side panel includes a foldable extension thereof, said extension being folded toward the interior of the sleeve to form a bottom of the packaging system; and further wherein

one of the side panel includes an internal slide card retaining element and a slide card locking mechanism, and another of said plurality of side panels includes a releasing mechanism.

14. The packaging system of claim 13 wherein each outer sleeve further includes a pair of notches for grasping and removing an internal slide card.

15. The packaging system of claim 14 wherein the internal slide card is comprised of one or more of a blister pack, a blister pack heat sealed to a substrate, a blister pack glued (e.g., hot melted) to a substrate, or a blister pack encased by a slotted substrate.

16. The packaging system of claim 13 wherein the outer sleeve is at least partially laminated with a polymeric film material.

17. The packaging system of claim 16 wherein the polymeric film material is laminated over an entire surface of the outer sleeve.

18. The packaging system of claim 13 wherein the outer sleeve is constructed from a paperboard or plastic substrate.
19. The packaging system of claim 13 wherein a receiving end of the outer sleeve includes a temporary seal comprised of one of a tuck closure, a perforated tear-away panel, and a security taped panel that can be removed to provide access to the internal slide card housed within.
20. A blank for forming a pair of lockable outer sleeves joined along a common hinge panel edge, each outer sleeve capable of housing an internal slide card, the blank comprising:
- a plurality of side panels; and
  - a plurality of hinge panels,
- wherein
- at least one of said side panel comprises an extension thereof forming an internal slide card retaining element;
  - at least one side panel thereof additionally comprises a slide card locking mechanism;
- and at least another side panel comprising a releasing mechanism; and
- at least one side panel additionally comprising a foldable extension for forming a bottom.
21. The blank of claim 20 wherein the slide card locking mechanism is in the form of a cutaway located in a side panel.

22. The blank of claim 21 wherein the cutaway additionally includes a node for engagement of an edge of an internal slide card.
23. The blank of claim 20 wherein the releasing mechanism is in the form of a release button located in a side panel.
24. The blank of claim 20 further including a polymeric film material laminated over at least a portion of one or both surfaces thereof.
25. A packaging system including an outer sleeve, wherein the outer sleeve comprises:  
a pair of side panels;  
a partition panel; and  
a plurality of hinge panels,  
wherein the side panels, partition panel, and hinge panels are operatively connected with each other such that the partition panel is disposed between the pair of side panels to define two separate inner chambers each capable of receiving and housing an internal slide card.
26. The packaging system of claim 25, further comprising a pair of slide cards, wherein each slide card includes an extension panel configured to enable the slide card to be retained within the outer sleeve.

27. The packaging system of claim 26, wherein each side panel further includes a first foldable extension configured to engage the foldable extension of the corresponding slide card to enable the slide card to be retained within the outer sleeve.

28. The packaging system of claim 26, wherein each slide card is movable between a first position and a second position, wherein each side panel further includes a cutout and a release button, wherein the cutout is configured to engage the foldable extension of the slide card when the slide card is in the first position, wherein the release button is configured to disengage the foldable extension of the slide card from the cutout to enable the slide card to be moved to the second position.

29. The packaging system of claim 28, wherein each side panel further includes a first foldable extension configured to engage the foldable extension of the corresponding slide card when the slide card is moved into the second position to enable the slide card to be retained within the outer sleeve.

30. The packaging system of claim 25, wherein each side panel further includes a node formed therein proximate to the cutout.

31. The packaging system of claim 26, wherein each slide card includes unit doses of medication.

32. A packaging system, comprising:

an outer sleeve including two chambers, wherein each chamber includes a locking mechanism, a release mechanism, and a retaining mechanism; and

two slide cards each housed within one of the chambers of the outer sleeve, wherein each slide card includes a locking/retaining mechanism, wherein each slide card is movable between a first position and a second position,

wherein the locking/retaining mechanism of the slide card engages the locking mechanism of the outer sleeve when the slide card is in the first position,

wherein the release mechanism of the outer sleeve is configured to disengage the locking/retaining mechanism of the slide card from the locking mechanism of the outer sleeve when the slide card is in the first position,

wherein the locking/retaining mechanism of the slide card is configured to engage the retaining mechanism of the outer sleeve when the slide card is moved from the first position to the second position.

FIGURE 1

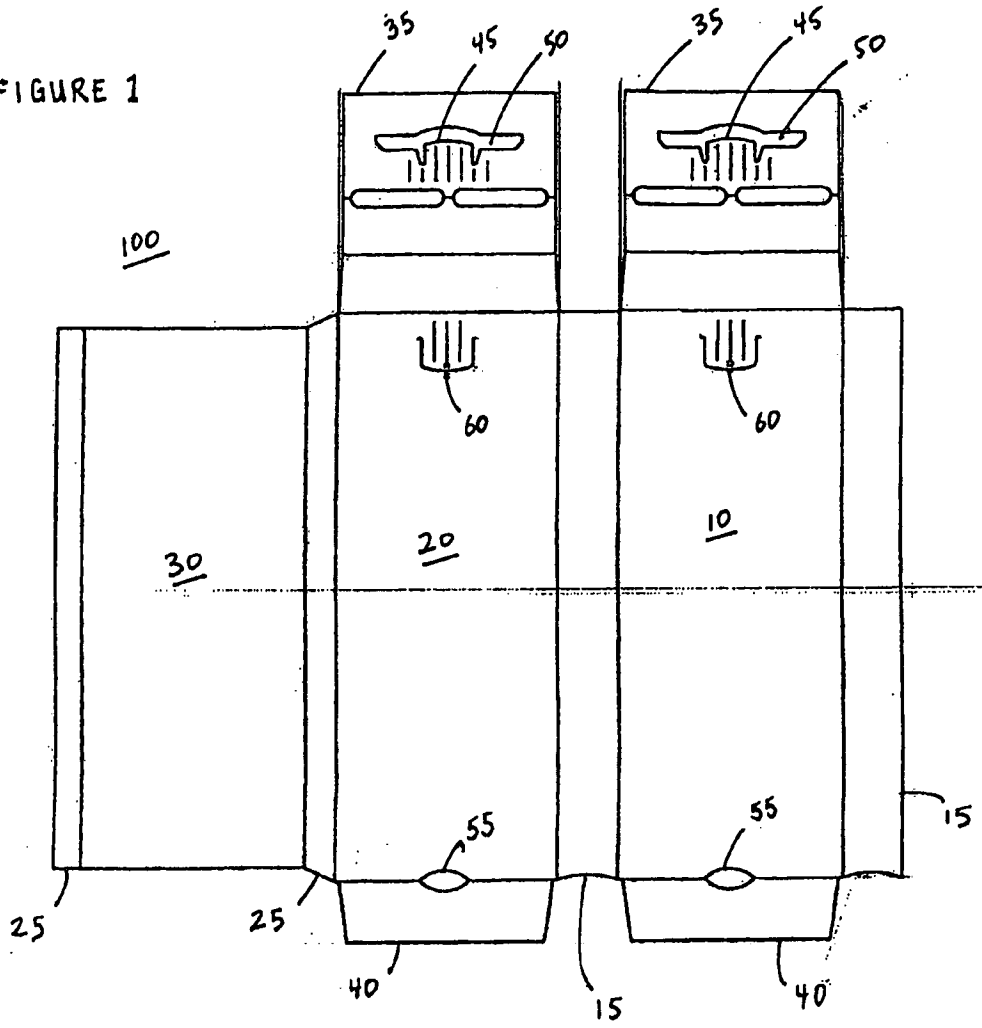

FIGURE 2

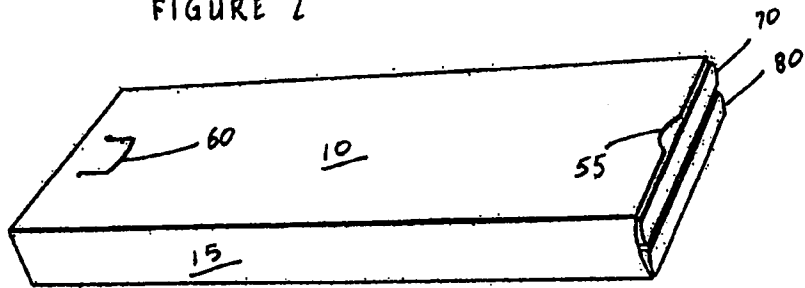
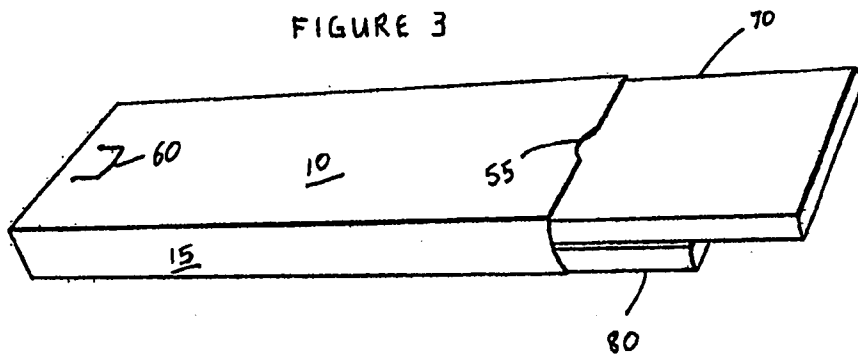

FIGURE 3



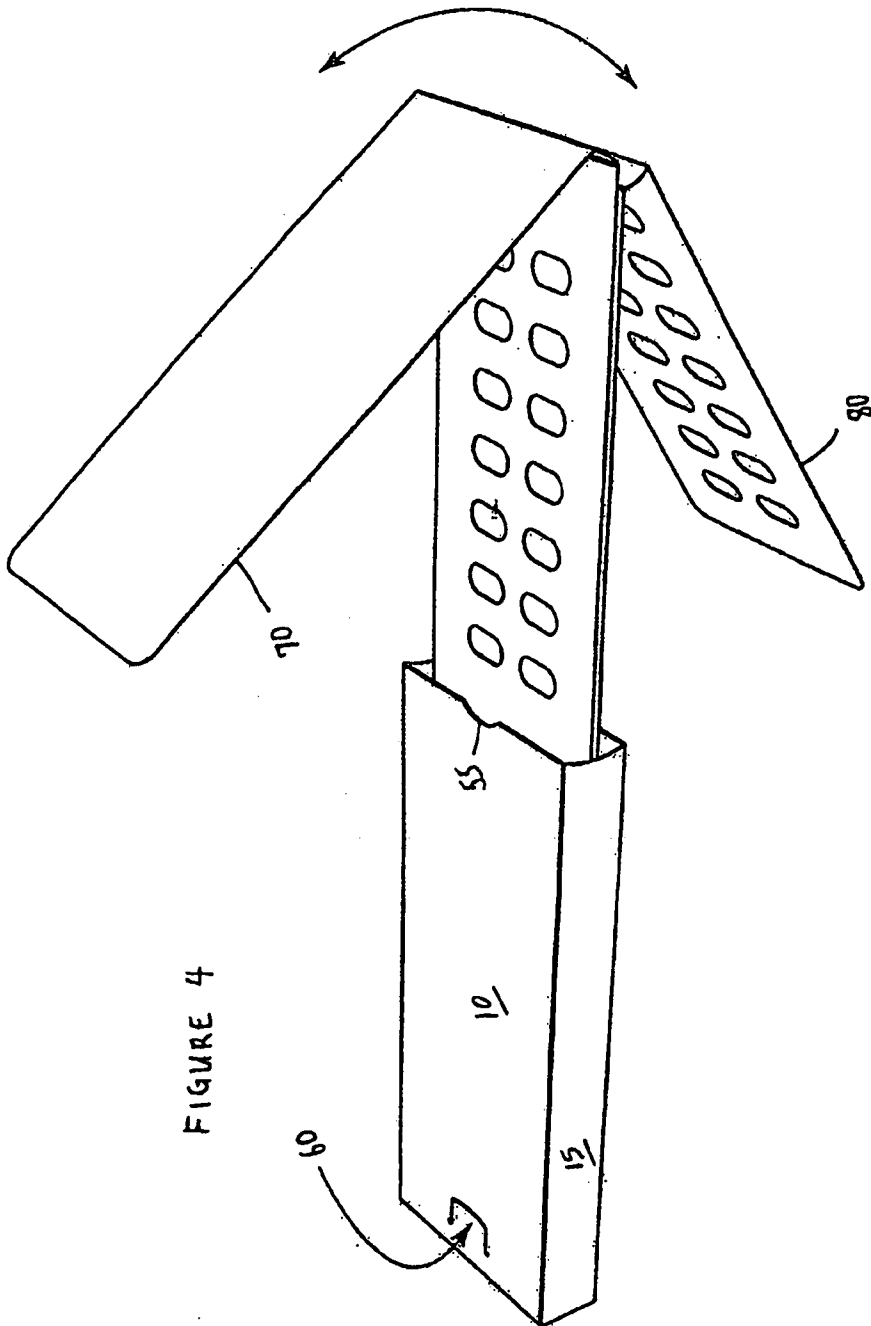

FIGURE 4

FIGURE 5

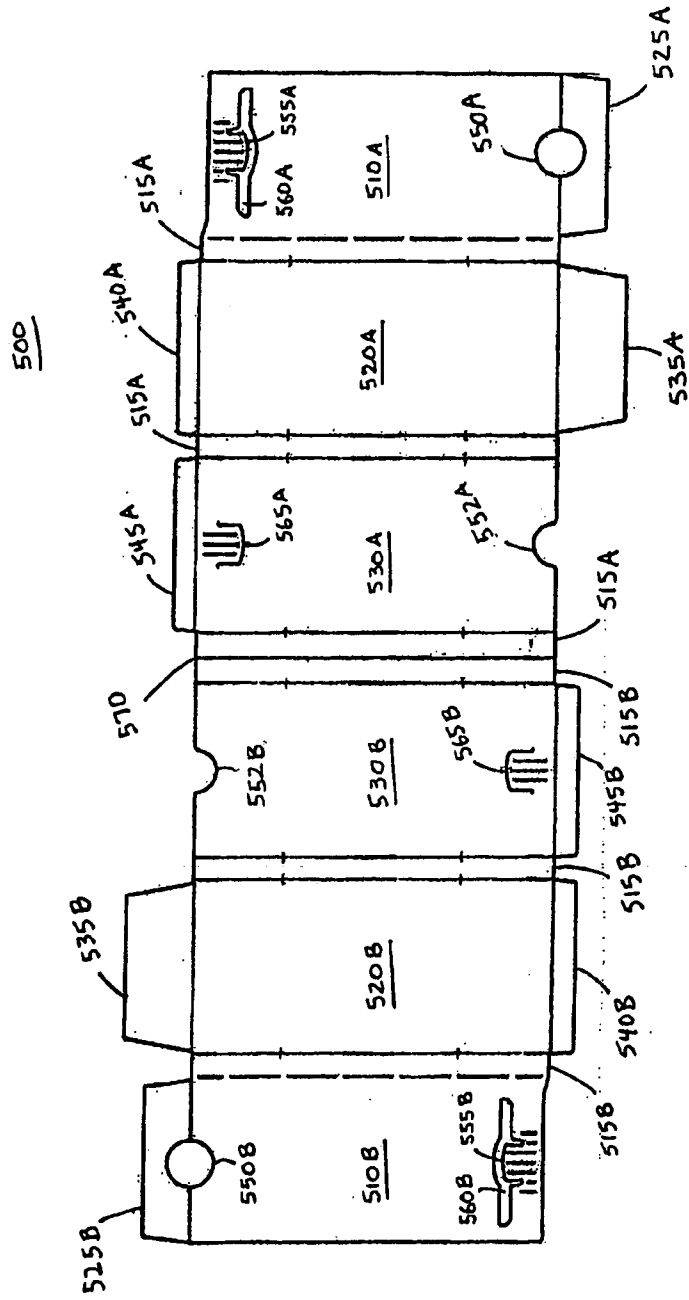

FIGURE 6

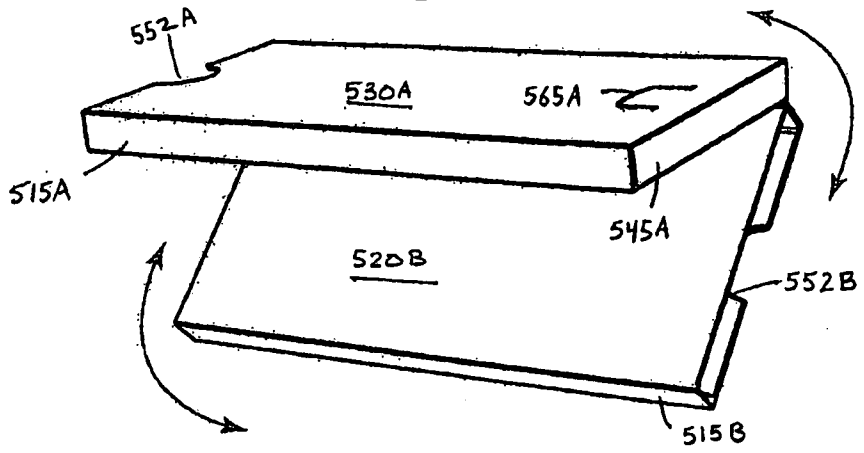

FIGURE 7

