

(No Model.)

H. H. COLES.
GRINDING MILL.

No. 318,700.

Patented May 26, 1885.

Fig. 1.

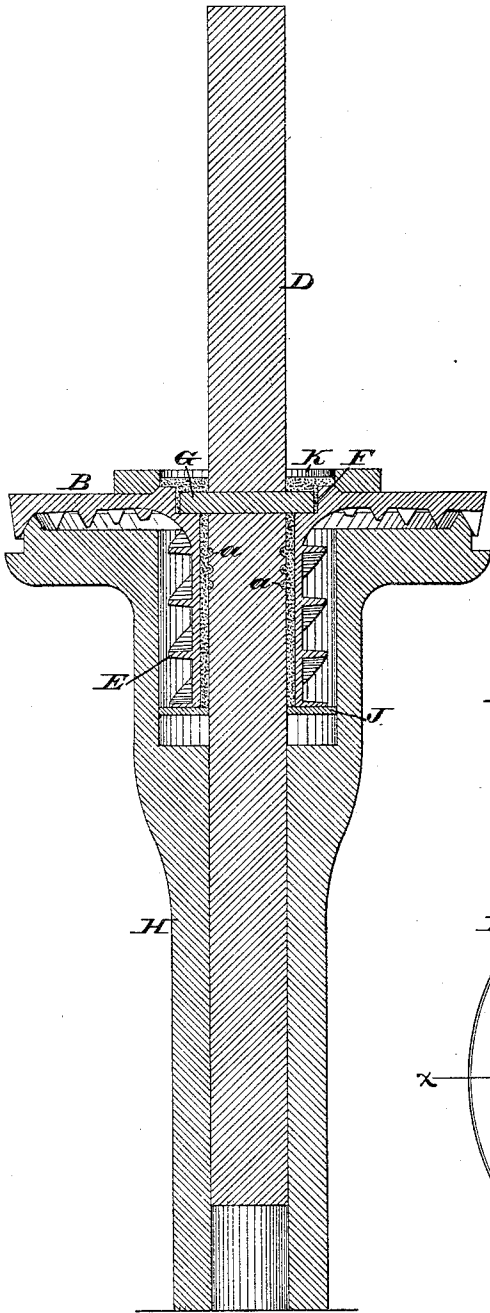

Fig. 3.

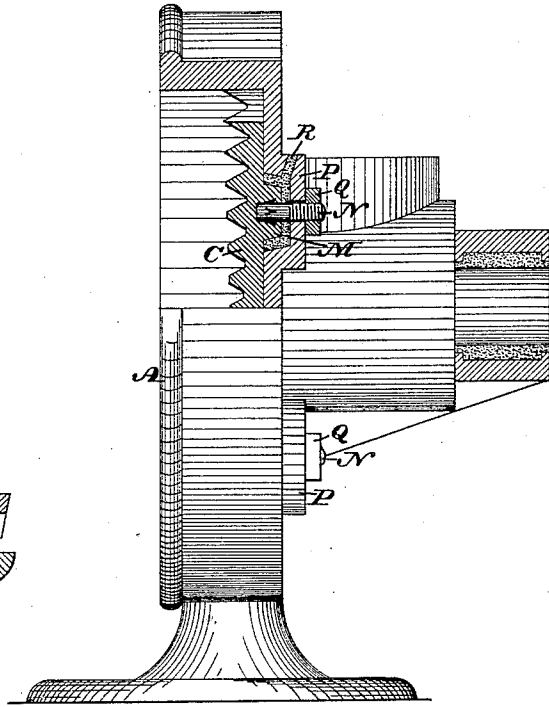
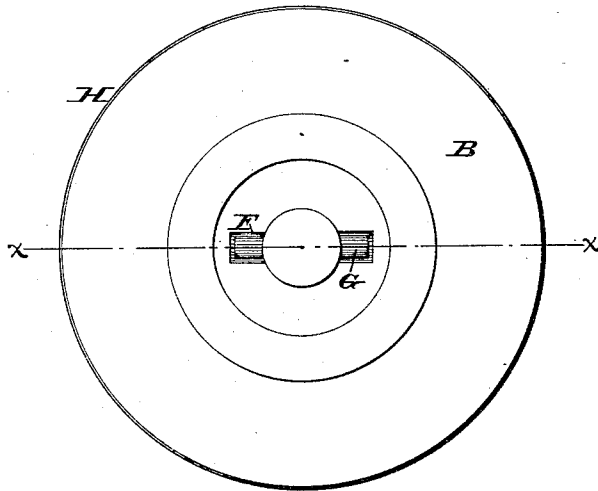

Fig. 2.



WITNESSES:

So. P. Grant,
W. F. Fischer

Henry H. Coles INVENTOR.

BY

John A. Diederichsen

ATTORNEY.

UNITED STATES PATENT OFFICE.

HENRI H. COLES, OF PHILADELPHIA, PENNSYLVANIA, ASSIGNOR TO HENRY TROEMNER, OF SAME PLACE.

GRINDING-MILL.

SPECIFICATION forming part of Letters Patent No. 318,700, dated May 26, 1885.

Application filed January 24, 1885. (No model.)

To all whom it may concern:

Be it known that I, HENRI H. COLES, a citizen of the United States, residing in the city and county of Philadelphia, State of Pennsylvania, have invented a new and useful Improvement in Grinding-Mills, which improvement is fully set forth in the following specification and accompanying drawings, in which—

Figure 1 represents a vertical section in line *xx*, Fig. 2, of a shaft and runner of a grinding-mill embodying my invention, and of the holder employed for sustaining said parts during the operation of connecting the same. Fig. 2 represents a top or plan view of the parts shown in Fig. 1. Fig. 3 represents a partial side elevation and partial vertical section of the casing of the mill and of the bed-plate thereof.

Similar letters of reference indicate corresponding parts in the several figures.

My invention consists in improved means for securing the runner of a grinding-mill to the shaft thereof, and also in the means for securing the bed-plate of the mill to the casing, all of which means will be hereinafter fully described and claimed.

Referring to the drawings, A represents the casing of a grinding-mill, and B the runner; C, the bed-plate, and D the shaft of said runner, said parts being formed of metal. Cast with or otherwise secured to the runner is a spiral conveyer, E.

In order to connect the runner with the shaft, the back of the runner is formed with recesses F, the same being around the central opening on opposite sides thereof, and the shaft has a cross-bar, G, which is adapted to enter said recesses. A space exists between the shaft and the wall of the central opening of the runner and spiral conveyer, and also between the cross-bar G and the walls of the recesses F. A holder, H, is employed to receive the shaft D in an upright position and the runner B in a horizontal position. The cross-bar G rests on the runner in the recesses F thereof, the position of parts being most clearly shown in Fig. 1. A stop, J, is placed within the recess which receives the spiral conveyer E, so as to close the space between said conveyer and the shaft D at the bottom of said recess, said stop being, if desired, simply a piece of paste-

board. An annulus or washer, K, is placed on the back of the runner and around the shaft. Babbitt or other suitable metal is poured through said washer K into the central opening of the runner, and it flows around the cross-bar G and the portion of the shaft within the runner and spiral conveyer to the stop J, and enters the grooves *a* in the shaft. The metal partly fills or may entirely fill the opening of the washer K, so that the cross-bar G and the portion of the back of the runner around the central opening are covered, the said opening thus being entirely closed. The shaft with the connected runner and spiral conveyer are withdrawn from the holder, the washer and stop being readily separated therefrom, it being seen that the runner and conveyer are firmly connected with the shaft. The metal which was inclosed by the washer K may be readily dressed or finished off, as desired, without affecting the back of the runner.

C represents the bed-plate of the mill, the same having on its back lugs, M, from which project rearward and horizontally the screw-bolts N, which are secured to said lugs M. The back of the casing A is formed with bosses P, which are adapted to receive the lugs M, and the bolts N pass through said bosses and have nuts Q, which tighten against the back of the bed-plate. A space exists between each lug M and boss P, and a gate, R, is formed in the lug in communication with said space. The bed-plate is properly adjusted by the nuts Q. Babbitt or other suitable metal is poured into the gates R, and flows around the lugs M and bolts N in the spaces between the nuts, lugs, and bosses, whereby the bed-plate is connected with the casing in a firm and durable manner, and rotation or shifting of the bed-plate is prevented.

It is evident that should either the runner or bed-plate become loose fresh metal may be applied to fill the spaces, thus again tightening the parts.

Having thus described my invention, what I claim as new, and desire to secure by Letters Patent, is—

1. The casing of a grinding-mill formed with bosses, the bed-plate having lugs, bolts, and

nuts, and Babbitt metal interposed in the joints between the lugs and bosses, combined and operating substantially as and for the purpose set forth.

5 2. A runner having the recess F and a shaft having a cross-bar, G, fitted therein, and Babbitt metal interposed in the joints between the cross-bar, runner, and shaft, combined and operating substantially as and for the purpose
10 set forth.

3. A runner and spiral conveyer, in combination with a shaft having grooves and provided with a cross-bar, and Babbitt metal interposed between said cross-bar, spiral conveyer, runner, and shaft, and filling said 15 grooves, substantially as described.

HENRI H. COLES.

Witnesses:

JOHN A. WIEDERSHEIM,
A. P. GRANT.