

(19) **DANMARK**

(10) **DK/EP 2912934 T3**



(12) **Oversættelse af
europæisk patentskrift**

Patent- og
Varemærkestyrelsen

-
- (51) Int.Cl.: **A 01 C 17/00 (2006.01)**
- (45) Oversættelsen bekendtgjort den: **2018-12-10**
- (80) Dato for Den Europæiske Patentmyndigheds bekendtgørelse om meddelelse af patentet: **2018-08-22**
- (86) Europæisk ansøgning nr.: **15401013.6**
- (86) Europæisk indleveringsdag: **2015-02-25**
- (87) Den europæiske ansøgnings publiceringsdag: **2015-09-02**
- (30) Prioritet: **2014-02-28 DE 102014102645**
- (84) Designerede stater: **AL AT BE BG CH CY CZ DE DK EE ES FI FR GB GR HR HU IE IS IT LI LT LU LV MC MK MT NL NO PL PT RO RS SE SI SK SM TR**
- (73) Patenthaver: **Amazonen-Werke H. Dreyer GmbH & Co. KG, Am Amazonenwerk 9-13, 49205 Hasbergen, Tyskland**
- (72) Opfinder: **Dreyer, Justus, Katharinenstr. 33c, 49076 Osnabrück, Tyskland**
- (74) Fuldmægtig i Danmark: **Patrade A/S, Ceresbyen 75, 8000 Århus C, Danmark**
- (54) Benævnelse: **Spredeapparat og fremgangsmåde til detektering af en massestrøm i et spredeapparat**
- (56) Fremdragne publikationer:
EP-A1- 0 963 690
DE-A1- 4 417 549
DE-A1- 19 908 141

Distribution device and method for detecting a mass flow in a distribution device

Description

5

The present invention relates to a distribution device and a method for detecting a mass flow in a distribution device. In particular, the present invention relates to a distribution device and a method, wherein a mass flow is corrected on the basis of a detected torque of a spreading disc and a correction variable.

10

Very large quantities of mineral fertilizer are discharged in agriculture to supplement the available nutrients for cultivated plants. More rapid growth, higher yields, and improved qualities can be achieved for cultivated plants by targeted addition of fertilizer, since the required soil nutrients and trace nutrients are often not available in the desired form and quantity in cultivated soil. In particular to meet a rising demand for nutrients, fertilizers are used in the agriculture field to meet the required increase of harvest quantities. The optimum use of fertilizers is not only important with respect to the costs linked to fertilizers, however, but rather also necessary in consideration of the possible risk of stresses to the soil fauna and the groundwater in the case of improper fertilizing. To effectively increase the yield, distributing the costliest fertilizers so that they can be optimally used by the plants without representing a risk for the environment is therefore unavoidable.

20

25 Greatly varying distribution technologies have been developed in the course of time for the discharge of the mineral fertilizers. In particular centrifugal fertilizer distributors have proven themselves for this purpose. In corresponding known distribution devices, a metered mass flow is fed to a rotating spreading disc, which is discharged by spreading blades arranged on the spreading disc.

30

In order that the fertilizer to be discharged can be distributed as accurately as possible, settings are to be performed beforehand on a distribution device, which are adapted to the type of fertilizer to be discharged as the spread material and

stipulate the desired operating width. In general, the material properties and the distribution properties for various fertilizers vary very strongly, and therefore the settings are to be corrected individually for each type of fertilizer to be discharged. However, the changes in the material properties are often not readily
5 recognizable to the farmer.

Also, for an ideal discharge of fertilizers, it is necessary to know the discharged quantity of fertilizer accurately, in particular to detect the mass flow discharged by a distribution device accurately. In conventional centrifugal devices, the mass
10 flow is determined on the basis of the torque of the spreading disc. In this case, the corresponding mass flow is determined for a measured torque of the spreading disc on the basis of a previously measured mass flow/torque characteristic curve. A corresponding centrifugal distributor is known from document EP 0 963 690 B1 and from DE 44 17 549 A1.

15 In these conventional centrifugal distributors, however, material-dependent properties of different types of fertilizers are not taken into consideration, and therefore if different types of fertilizers are used, errors occur in the determination of the mass flow. It is also possible that mechanical properties of a stored type of fertilizer change over time, for example, the solidity of particles of
20 a stored type of fertilizer can decrease as a result of moisture. The consequence is also a faulty determination of the mass flow.

Proceeding from the above-described prior art, it is an object to provide a
25 distribution device and a method which avoid the above-mentioned problems.

The present invention proposes as a solution a distribution device and a method for detecting a mass flow in a distribution device, wherein a corrected mass flow is determined on the basis of a correction variable and a detected torque.

30 In one aspect of the present invention, a method is provided for detecting a mass flow in a distribution device having a spreading disc for distributing material fed to the spreading disc. In exemplary embodiments, the method comprises driving

the at least one spreading disc so that it rotates about a rotational axis, feeding the material to the at least one rotating spreading disc, detecting a torque which is necessary to drive the at least one rotating spreading disc, and determining a corrected mass flow of the material fed to the spreading disc, on the basis of the
5 correction variable and the detected torque. The correction variable can be based in this case on a coefficient of friction of the material on the spreading disc and/or a period for which the material is present on the spreading disc and/or an ejection angle of the material relative to a feed direction in which the flow of material is fed to the spreading disc, and/or an ejection direction of the material. A
10 determination of a corrected mass flow is achieved in this case by the correction variable, wherein friction influences, which are dependent on the type of fertilizer used, are considered in the determination of the mass flow. More accurate determination of the discharged mass is thus possible, without torque/mass flow relationships being determined for different types of fertilizer under different
15 conditions.

In a further advantageous embodiment herein, the determination of the corrected mass flow can comprise determining a corrected torque on the basis of the correction variable and determining the corrected mass flow from the corrected
20 torque by means of a known mass flow/torque relationship. In this case, influences can be taken into consideration which act on the torque, without having to record new torque/mass flow relationships beforehand. Accurate mass determination is thus enabled.

25 In another advantageous embodiment herein, the determination of the corrected mass flow can comprise determining a mass flow value from a known mass flow/torque relationship on the basis of the detected torque and correcting the mass flow value on the basis of the correction variable. In this case, a correction can be performed in consideration of various influences in a simple manner.

30

In some advantageous embodiments, the method can also comprise determining a correction factor from the correction variables as a function of the radius of the spreading disc and/or a moment of inertia of the spreading disc and/or a rotational

speed of the spreading disc and/or a cross section of the flow of material which is fed to the spreading disc, wherein the corrected mass flow is determined on the basis of the correction factor. A simple correction can be provided on the basis of a correction factor as a function of spreading disc parameters, which takes into
5 consideration different disc configurations.

In some advantageous embodiments, the determination of the correction variable can comprise detecting the coefficient of friction and/or the ejection angle and/or the ejection direction by means of a sound sensor and/or a light sensor and/or a
10 force sensor and/or a video camera and/or a radar sensor device. The correction variable can be determined in a simple manner in this case.

In some advantageous embodiments, the determination of the correction variable can comprise selecting the coefficient of friction from one or more stored
15 databases, tables, experience values, or characteristic curves. A simple correction of the mass flow on the basis of stored data of the coefficient of friction is thus enabled.

In some advantageous embodiments, the spreading disc can also have at least one
20 spreading blade which is arranged outside the radial with respect to the rotational axis. In spreading discs having at least one spreading blade arranged outside the radial, an accurate mass determination can be performed independently of the friction behavior of the material.

25 In another aspect of the present invention, a distribution device is provided. In illustrative embodiments, the distribution device can comprise at least one spreading disc which is configured to rotate about a rotational axis to discharge in an ejection angle range a material which is fed to the spreading disc, a torque detection device which is configured to detect a torque which is fed to the at least
30 one spreading disc in order to drive it, a sensor device which is configured to detect a correction variable, and an electronic evaluation unit which is configured to determine a corrected mass flow of the material fed to the spreading disc, on the basis of the correction variable and the torque which is detected by the torque

detection device. In this case, the correction variable can be based on a coefficient of friction of the material on the spreading disc and/or a period for which the material is present on the spreading disc and/or an ejection angle of the material relative to a feed direction in which the flow of material is fed to the spreading disc, and/or an ejection direction of the material. A determination of a corrected mass flow is achieved in this case by the correction variable, wherein friction-dependent influences on the determination of the mass flow, which are a function of the type of fertilizer used, are taken into consideration. More accurate determination of the discharged mass is thus possible, without torque/mass flow relationships being determined for different types of fertilizer under different conditions.

In one more advantageous embodiment herein, the electronic evaluation unit can be configured to determine a corrected torque on the basis of the correction variable and to access a known mass flow/torque relationship in order to determine the corrected mass flow on the basis of the corrected torque by means of the known mass flow/torque relationship. In this case, influences can be taken into consideration by the evaluation unit which have an effect on the torque, without new torque/mass flow relationships having to be recorded beforehand. An accurate mass determination is thus enabled.

In another more advantageous embodiment herein, the electronic evaluation unit can also be configured to access a known mass flow/torque relationship in order to determine the corrected mass flow by means of a determination of a mass flow value on the basis of the known mass flow/torque relationship and the detected torque and to correct the mass flow on the basis of the correction variable. In this case, a correction can be performed by the evaluation unit in a simple manner in consideration of various influences.

In several advantageous embodiments, the electronic evaluation unit can also be configured to determine a correction factor from the correction variable as a function of the radius of the spreading disc and/or a moment of inertia of the spreading disc and/or the rotational speed of the spreading disc and/or a cross

section of the stream flow of the material which is fed to the spreading disc, in order to determine the corrected mass flow on the basis of the correction factor. In dependence on spreading disc parameters, the evaluation unit can enable a simple correction on the basis of a correction factor, in which different disc configurations are also considered.

In several advantageous embodiments, the electronic evaluation unit can also comprise a memory with one or more databases, tables, experience values, or characteristic curves stored therein for determining the correction variable on the basis of the coefficient of friction. The distribution device thus enables a simple correction of the mass flow on the basis of data of the coefficient of friction stored in the memory of the evaluation unit.

In several advantageous embodiments, the sensor device can comprise at least one sound sensor and/or a light sensor and/or a force sensor and/or a video camera and/or a radar sensor device. In this case, the sensor device can enable a simple determination of the correction variable.

In several advantageous embodiments, the spreading disc can have at least one spreading blade which is arranged outside the radial with respect to the rotational axis.

Further features, advantageous embodiments, and advantages of the present invention are disclosed in the appended patent claims and the following detailed description of illustrative embodiments, wherein reference is made to the following figures.

Figure 1 schematically shows a distribution device according to several illustrative embodiments of the present invention;

30

Figure 2 schematically shows a top view of a spreading disc according to several illustrative embodiments of the present invention;

- Figure 3 schematically shows an outline sketch of a portion of a spreading disc in an enlargement during operation in a top view according to exemplary embodiments of the present invention;
- 5 Figure 4 schematically shows a flow chart of the determination of a corrected mass flow according to several illustrative embodiments of the invention; and
- 10 Figure 5 schematically shows another flow chart of the determination of a corrected mass flow according to other illustrative embodiments of the invention.

Figure 1 schematically shows a distribution device for discharging material to be spread, for example, fertilizer, according to various exemplary embodiments of the invention. The distribution device according to Figure 1 has in this case a storage container 1 having at least one metering device 2, via which material to be discharged is fed in settable quantities to a spreading disc 3 driven to rotate. Although only one spreading disc 3 is shown in Figure 1, the distribution device can alternatively have two or more spreading discs. The spreading disc 3 and the metering device 2 can be adjustable in relation to one another, and therefore the position of the dispensing point of the material to be spread on the spreading disc 3 can be changed. Motorized setting means 6 for setting the metering device 2 and/or motorized setting means 7 for setting the dispensing point can be provided for this purpose. Furthermore, spreading blades 20, 21 are arranged on the spreading disc 3 to discharge material to be spread, which is fed to the spreading disc 3 driven to rotate. Although two spreading blades 20, 21 are arranged on the spreading disc 3 according to the illustration, alternatively one spreading blade or more than two spreading blades can be provided.

30 The drive of the spreading disc 3 can be performed, for example, by the PTO shaft of a tractor 18 via a transmission 26. Alternatively, the spreading disc 3 can be driven by a hydraulic motor (not shown) or via suitable devices, for example, by the hydraulic system of a tractor or a hydraulic, which is driven by a motor by

the tractor or using other means. A control device (not shown), by means of which a rotational speed of the spreading disc 3 can be set, can be associated with the drive of the spreading disc 3.

5 A rotational speed sensor 14 can also be provided to detect the rotational speed of the spreading disc 3. A torque fed for the drive of the spreading disc 3 can be detected via a torque sensor 8. A rotational angle sensor 16 can also be provided, by means of which the rotational angle of the centrifugal disc 3 can be determined.

10

An evaluation unit 15 is also provided, as shown in Figure 1, wherein the evaluation unit 15 can also execute control functions of the spreading disc 3 and the metering system 6, 7. The evaluation unit 15 also has a memory (not shown), in which data with respect to the distribution device and/or a distribution procedure to be executed are stored. The evaluation unit 15 can be connected via lines or by other transmission means to the individual sensors 8, 14, 16, and therefore the values determined by the sensors 8, 14, 16 can be transmitted to the evaluation unit 15. For example, the evaluation unit can monitor, control, and regulate the distribution procedure from the tractor seat by hand or automatically.

20

A sensor arrangement 19 which can be positioned in the circumferential direction of the spreading disc 3 is also provided, to detect a spreading profile of a mass flow discharged by the spreading disc. A spreading width of the discharged mass flow can be detected by the sensor 19, for example. Alternatively, the sensor arrangement 19 can comprise a plurality of sensors, which are arranged in the circumferential direction around the spreading disc 3. According to exemplary embodiments, the sensor arrangement 19 can comprise at least one optical sensor and/or at least one force sensor. The sensor arrangement 19 can additionally or alternatively have a camera. Additionally or alternatively, the sensor device 19 can comprise a radar sensor device. The sensor arrangement 19 is connected to the evaluation unit 15, and therefore data detected by the sensor arrangement 19 can be transmitted to the evaluation unit.

30

Exemplary embodiments of the spreading disc 3 will be described on the basis of Figure 2. The spreading disc 3 is schematically illustrated in a top view in Figure 2. In the illustrated exemplary embodiment, the spreading blades 20 and 21 are each fastened using a bolt 312 in the vicinity of the hub 313 of the spreading disc 3. In this case, the spreading blades 20 and 21 are arranged so they can be pivoted in the angle about the bolts 312. A further mounting of the spreading blades 20, 21 on the spreading disc 3 is performed via a further bolt 314 or 315, respectively. The bolts 314 and 315 engage in oblong holes 316 and 317, which are formed in the surface of the spreading disc 3. The oblong holes 316 and 317 therefore represent guides for the corresponding bolts 314 and 315, and therefore the spreading blades 20, 21 can be oriented and arranged on the surface of the spreading disc 3 at a predefined angle in relation to a radial direction of the spreading blade 3. For controlled setting of a desired orientation and arrangement, positioning devices 318, 319 can be provided, which can engage on the respective bolts 314 and 315. In some exemplary embodiments, the positioning devices 318, 319 can be designed as electrically actuated positioning motors. Alternatively, the positioning devices 318, 319 can be formed as manually-operable devices. Orientations of the spreading blades 20 and 21 can be set during a spreading procedure via the positioning devices 318 and 319 in order to perform an adaptation on the spreading profile, for example.

In exemplary embodiments in which electric positioning motors are provided, a power supply of the positioning motors can take place, for example, via lines 320, as shown in Figure 2. The lines 320 can be supplied with power, for example, via a type of slip ring device 21. The positioning devices 318, 319 can also be connected to a control and regulating device (not shown), which is arranged on the tractor or on the centrifugal fertilizer distributor. Via this regulating device, for example, orientations of the spreading blades 20 and 21 on the spreading disc 3 can be changed jointly or separately from one another, for example, from the tractor seat by hand or automatically by the regulating device. In some exemplary embodiments, the positioning devices 318, 319 can be connected to the evaluation unit (cf. Figure 1) and can be controlled thereby.

It is to be noted that the exemplary embodiments described on the basis of Figure 2 do not represent a restriction of the present invention and alternatively the spreading blades 20, 21 can be fastened on the spreading disc 3 by at least one
5 fastening means (for example, bolts, rivets, etc.). In particular, at least one spreading blade 20, 21 can be attached fixed in place on the spreading disc 3.

In general orientations, the spreading blades are not arranged aligned radially on the spreading disc, in particular the spreading blades can be arranged and oriented
10 such that the angle coordinate in planar polar coordinates along the spreading disc is not constant, i.e., a constant angle coordinate cannot be associated with a radially extending surface or edge in planar polar coordinates. The spreading blades can thus generally be arranged and oriented outside the radial on the surface of the spreading blade.

15

The forces acting on a particle of a spread material will be discussed hereafter on the basis of Figure 3. Figure 3 represents a greatly simplified top view of a portion of the spreading disc 3 in an enlarged view, in which only the spreading blade 20 and a particle P of a spread material are schematically shown. It is to be
20 noted that Figure 3 does not represent a drawing to scale and in particular the forces represented in Figure 3 are not shown to scale.

The spreading blade 20 is arranged outside the radial on the spreading disc 3, wherein the spreading blade 20 is arranged spaced apart by a distance d from a
25 center point M (geometrical center point, but also point of intersection of the rotational axis with the spreading disc) of the spreading disc 3 such that a straight line (not shown) parallel to the spreading blade 20 in Figure 3 having distance d to the spreading blade 20 has the center point M. Therefore, a radial direction R extending through the center of gravity of the particle P intersects the spreading
30 blade 20 at an angle α , which is determined by the radial distance of the particle to the center point M and by the distance d .

The radial direction R and a tangential direction T, which is oriented

perpendicular to the radial direction R, are defined with respect to the particle P. A rotational direction of the spreading disc 3 is identified by an arrow D. The rotation of the spreading disc 3 occurs at constant angular velocity, although this does not represent a restriction of the present invention.

5

The particle P experiences a centrifugal force FZ acting along the radial direction and a Coriolis force FC acting along the tangential direction T due to the rotational movement of the spreading disc 3. The Coriolis force FC comprises a normal component FCN acting perpendicularly to the spreading blade 20, which
10 can be associated with a friction force FR, which counteracts the movement of the particle P along the spreading blade 20, via a coefficient of friction of the particle P on the spreading blade 20. The friction force FR may be decomposed into a radial component FRR acting along the radial direction R and a tangential component FRT acting along the tangential direction T, since the radial direction
15 R and the spreading blade 20 form the angle α , which is not equal to 0° . The forces acting along the tangential direction result in a torque M, which is fed to the spreading disc 3, to accelerate the particle P along the spreading blade 20. As shown in Figure 3, a contribution to the torque induced by the particle P is proportional to (FC - FRT), since FC and FRT are oriented antiparallel in relation
20 to one another. It thus results that a spreading blade arranged outside the radial supplies a contribution to the torque dependent on the friction. In contrast, the friction force acts along the radial direction in the case of radially arranged spreading blades and therefore does not contribute to the torque. With increasing angle α , the friction increasingly contributes to the torque (angle dependence is
25 proportional to sine). In the illustrated example, the component FRT reduces the torque which is required to drive the spreading blade 20 in the presence of the particle P in comparison to a radially oriented spreading blade.

The orientation of the spreading blade illustrated in Figure 3 does not represent a
30 restriction of the present invention. In one example (not shown), a spreading blade can be arranged such that the spreading blade is displaced parallel downward with a distance greater than d from the spreading blade 20 in relation to the spreading blade 20 illustrated in Figure 3. It is to be noted that in this

example (not shown), a friction force on a particle would have a tangential component which would be oriented toward the spreading blade. In the example (not shown), an increase of the torque required to drive the spreading disc in the presence of a particle would result in relation to a radially oriented spreading
5 blade.

The present invention presumes that the torque for driving the spreading disc 3 is influenced as a function of the orientation of the spreading blade by the friction force of the spread material. Different types of spread material, for example,
10 different types of fertilizer, can have different coefficients of friction and/or the coefficient of friction can change in dependence on the storage conditions of the spread material, and therefore the friction force can be different for different types of spread material and/or can be dependent on the storage conditions. It has
15 thus been recognized that the torque for driving the spreading blade 3 in the presence of spread material is no longer only dependent on the mass flow but rather also on the type of the spread material and/or the storage conditions. In the case of a determination of a mass flow of spread material which is fed to a spreading disc by measuring a torque of the spreading disc and determining a
20 mass flow from the torque, for example, on the basis of a mass flow/torque characteristic curve or the like, without consideration of the type of the spread material, it is generally to be presumed that a value deviating from an actual mass flow will be derived.

Exemplary embodiments of the invention will be described on the basis of
25 Figures 4 and 5. Figure 4 schematically shows a sequence for detecting a mass flow in a distribution device having a spreading disc for distributing a material which is fed to the spreading disc according to several exemplary embodiments of the invention. In this case, a torque for driving the spreading disc is detected. Also, a correction variable is determined. The detected torque is corrected on the
30 basis of the correction variable. Also, a corrected mass flow is determined on the basis of the corrected torque. Figure 5 schematically shows an alternative sequence for detecting a mass flow in a distribution device having a spreading disc for distributing a material which is fed to the spreading disc according to

other exemplary embodiments of the invention. In this case, a torque for driving the spreading disc is detected, on the basis of which a mass flow is determined. A correction variable is also determined. The mass flow determined on the basis of the torque is corrected on the basis of the correction variable and a corrected mass
5 flow is determined.

The correction variable can be determined in this case on the basis of a coefficient of friction of the material on the spreading disc and/or a period for which the material is present on the spreading disc and/or an ejection angle of the
10 material relative to a feed direction in which the flow of material is fed to the spreading disc, and/or an ejection direction of the material. For example, by means of an ejection angle at which a metered quantity of spread material is fed to the spreading disc, a period for which the material is present can be determined, on the basis of which the correction variable can be determined.

15 In a special example, the coefficient of friction can be derived from the period for which the material is present.

In a special example, the period for which the material is present can be
20 determined from a mean ejection angle. For example, the mean ejection angle can be determined from a maximum in the curve of the torque via a rotational angle of the disc in relation to a discharge direction. In another example, the period for which the material is present can be obtained on the basis of one or more images of the spread material quantity applied to the spreading disc recorded by a
25 camera.

Additionally or alternatively, the coefficient of friction of the material on the spreading disc can be determined by measurements. For example, values for a coefficient of friction of the material of the spread material with respect to the
30 material of the spreading disc and/or the spreading blades can be determined from comparison measurements to the material of the spread material with respect to the material of the spreading disc and/or the spreading blades.

Additionally or alternatively, an ejection direction can be determined. For example, an ejection direction can be determined from a spreading profile, on the basis of which an ejection angle can be determined. In a specific example, an
5 ejection direction and/or a mean ejection direction can be determined from a maximum value of ejected material from sensors arranged in the circumferential direction around the spreading disc and/or a sensor which can be positioned in the circumferential direction.

10 In several exemplary embodiments, the correction variable can be determined by means of the evaluation unit on the basis of tables, and/or formulas based on theoretical and/or empirical models, and/or measured and/or updated characteristic curves from the coefficient of friction and/or the ejection angle and/or the ejection direction and/or the period for which the material is present. In
15 several exemplary embodiments, the coefficient of friction is selected from one or more stored databases, tables, experience values (for example, from previously performed measurements), LUTs, characteristic curves, or the like or determined from theoretical or empirical models. For this purpose, the data relating to the coefficient of friction of different spread materials can be stored in a memory of
20 the evaluation unit (cf. 15 in Figure 1) to be retrieved as needed. For example, an operator of the distribution device inputs the type of spread material into the evaluation unit or selects the spread material and the corresponding coefficient of friction manually from the stored data to determine the coefficient of friction from the stored data.

25 In several exemplary embodiments, for example, a correction factor can be determined based on the correction variable to obtain a simple correction of the torque and/or the mass flow. In several examples herein, the correction factor can be determined from the correction variable as a function of the radius of the spreading disc and/or a moment of inertia of the spreading disc and/or the
30 rotational speed of the spreading disc and/or a cross section of the stream flow of the material which is fed to the spreading disc, wherein the corrected mass flow is determined on the basis of the correction factor.

A distribution device and a method having a determination of a corrected mass flow are provided. For this purpose, a torque of a spreading disc is detected, which is provided for discharging a material. On the basis of the detected torque
5 and a correction variable based on a coefficient of friction of the material on the spreading disc and/or a period for which the material is present on the spreading disc and/or an ejection angle of the material relative to a feed direction in which the flow of material is fed to the spreading disc, and/or an ejection direction of the material, the corrected mass flow is determined.

PATENTKRAV

1. Fremgangsmåde til detektering af en massestrøm i et spredeapparat med mindst en spredeskive (3) til fordeling af materiale, som er tilført fra spredeskiven (3), omfattende:

5

Drivning af den mindst ene spredeskive (3), således at denne roterer omkring en rotationsakse;

tilførsel af materialet til den mindst ene roterende spredeskive (3);

10

detektering af et drejningsmoment, som er nødvendigt til drivning af den mindst ene roterende spredeskive (3), **kendetegnet ved, at**

fremgangsmåden desuden omfatter:

15

Bestemmelse af en korrektionsstørrelse på basis af en friktionskoefficient for materialet på spredeskiven (3) og/eller en opholdsvarighed for materialet på spredeskiven (3) og/eller en udkastvinkel for materialet i forhold til en tilførselsretning, langs hvilken materialestrømmen tilføres til spredeskiven (3), og/eller en udkastretning for materialet; og

20

bestemmelse af en korrigeret massestrøm af det til spredeskiven (3) tilførte materiale på basis af korrektionsstørrelsen og det detekterede drejningsmoment.

25

2. Fremgangsmåde ifølge krav 1, hvorved bestemmelsen af den korrigerede massestrøm omfatter en bestemmelse af et korrigeret drejningsmoment på basis af korrektionsstørrelsen og en bestemmelse af den korrigerede massestrøm på basis af det korrigerede drejningsmoment ved hjælp af en bekendt relation mellem massestrøm og drejningsmoment.

30

3. Fremgangsmåde ifølge krav 1, hvorved bestemmelsen af den korrigerede massestrøm omfatter en bestemmelse af en massestrøm-værdi på basis af en kendt relation mellem massestrøm og drejningsmoment på basis af det detekterede drejningsmoment samt en korrigering af massestrøm-værdien på basis af korrektionsstørrelsen.

4. Fremgangsmåde ifølge et af kravene 1 til 3, ydermere omfattende en bestemmelse af en korrektionsfaktor på basis af korrektionsstørrelsen i afhængighed af spredeskivens (3) radius og/eller spredeskivens (3) inertimoment og/eller spredeskivens (3) omdrejningstal og/eller et tværsnit af den til spredeskiven (3) tilførte materialestrøm, 5 hvorved den korrigerede massestrøm bestemmes på basis af korrektionsfaktoren.
5. Fremgangsmåde ifølge et af kravene 1 til 4, hvorved bestemmelsen af korrektionsstørrelsen omfatter detektering af friktionskoefficienten og/eller udkastvinklen og/eller udkastretningen ved hjælp af en lydsensor og/eller en lyssensor og/eller en kraftsensor 10 og/eller et videokamera og/eller et radarsensorapparat.
6. Fremgangsmåde ifølge et af kravene 1 til 5, hvorved bestemmelsen af korrektionsstørrelsen omfatter udvælgelse af friktionskoefficienten fra en eller flere lagrede databaser, tabeller, empiriske værdier eller karakteristiske kurver. 15
7. Fremgangsmåde ifølge et af kravene 1 til 6, hvorved den mindst ene spredeskive (3) desuden mindst omfatter en spredeskivl (20, 21), der i forhold til rotationsaksen er anbragt ikke-radialt. 20
8. Sprededeparat, omfattende:
- Mindst en spredeskive (3), som er konfigureret med henblik på rotation omkring en rotationsakse for i et udkastvinkelområde at udbringe et materiale, som tilføres til den mindst ene spredeskive (3); 25 drejningsmoment-detekteringsapparat (8), der er konfigureret til at detektere et drejningsmoment, der med henblik på drivning af den mindst ene spredeskive (3) udøves på denne;
- kendetegnet ved, at**
- sprededeparatet ydermere omfatter: 30
- Sensorapparat (19), der er konfigureret til at detektere en korrektionsstørrelse på basis af en friktionskoefficient for materialet på spredeskiven (3) og/eller en opholdstid for materialet på spredeskiven (3) og/eller en udkastvinkel for materialet i forhold til en tilfør-

5 selsretning, langs hvilken materialestrømmen tilføres til spredeskiven (3), og/eller en udkastretning for materialet; og elektronisk vurderingsenhed (15), der er konfigureret til at bestemme en korrigeret massestrøm af det til spredeskiven (3) tilførte materiale på basis af korrektionsstørrelsen og det af drejningsmoment-detekteringsapparatet detekterede drejningsmoment.

10 9. Sprededeapparat ifølge krav 8, hvorved den elektroniske vurderingsenhed (15) er konfigureret til at bestemme et korrigeret drejningsmoment på grundlag af korrektionsstørrelsen og med henblik på tilgang til en kendt relation mellem massestrøm og drejningsmoment med henblik på at bestemme den korrigerede massestrøm på basis af det korrigerede drejningsmoment ved hjælp af den kendte relation mellem massestrøm og drejningsmoment.

15 10. Sprededeapparat ifølge krav 8, hvorved den elektroniske vurderingsenhed (15) er konfigureret med henblik på tilgang til en kendt relation mellem massestrøm og drejningsmoment, med henblik på at bestemme den korrigerede massestrøm ved hjælp af en bestemmelse af en massestrømværdi på basis af den kendte relation mellem massestrøm og drejningsmoment og det detekterede drejningsmoment samt at korrigere
20 massestrømværdien på basis af korrektionsstørrelsen.

25 11. Sprededeapparat ifølge et af kravene 8 til 10, hvorved den elektroniske vurderingsenhed (15) endvidere er konfigureret til at bestemme en korrektionsfaktor på basis af korrektionsstørrelsen i afhængighed af spredeskivens (3) radius og/eller et inertimoment for spredeskiven (3) og/eller spredeskivens (3) omdrejningstal og/eller et tværsnit af materialestrømmen, som tilføres til spredeskiven (3), med henblik på at bestemme den korrigerede massestrøm på basis af korrektionsfaktoren.

30 12. Sprededeapparat ifølge et af kravene 8 til 11, hvorved den elektroniske vurderingsenhed (15) ydermere omfatter en hukommelse med en eller flere deri lagrede databaser, tabeller, empiriske værdier eller karakteristiske kurver til bestemmelse af korrektionsstørrelsen på basis af friktionskoefficienten.

13. Sprededeapparat ifølge et af kravene 8 til 12, hvorved sensorindretningen (19) mindst omfatter en lydsensor og/eller en lyssensor og/eller en kraftsensor og/eller et videokamera og/eller et radarsensorapparat.

5 14. Sprededeapparat ifølge et af kravene 8 til 13, hvorved spredeskiven (3) omfatter mindst en spredeskivl (20, 21), der er placeret ikke-radialt i forhold til rotationsaksen.

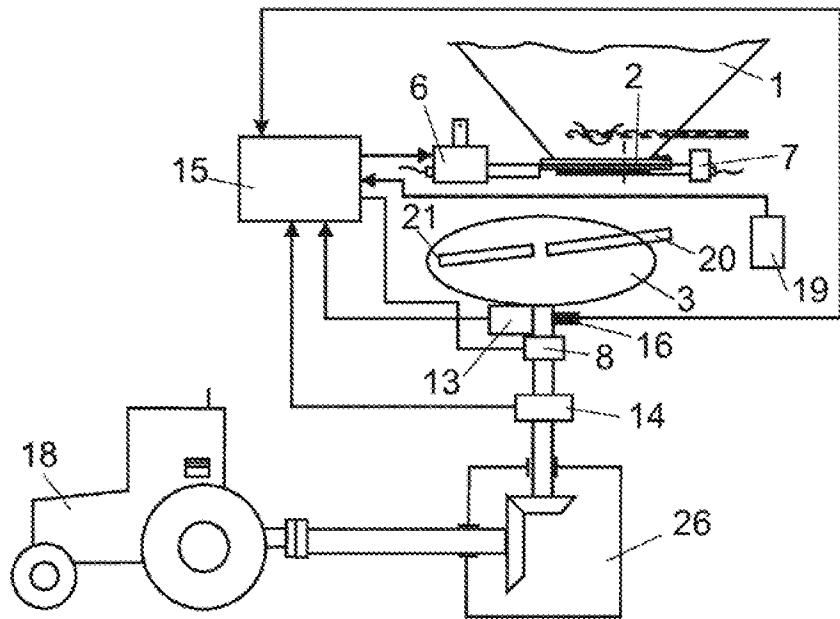

Fig. 1

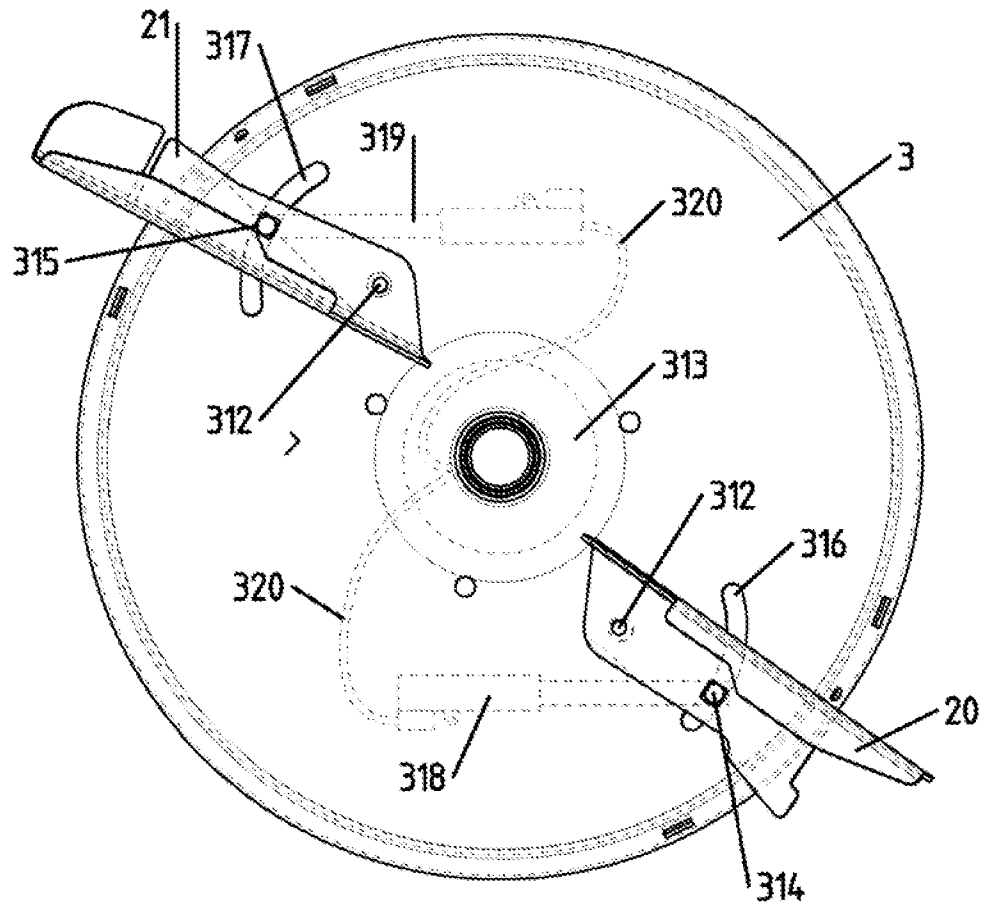

Fig. 2

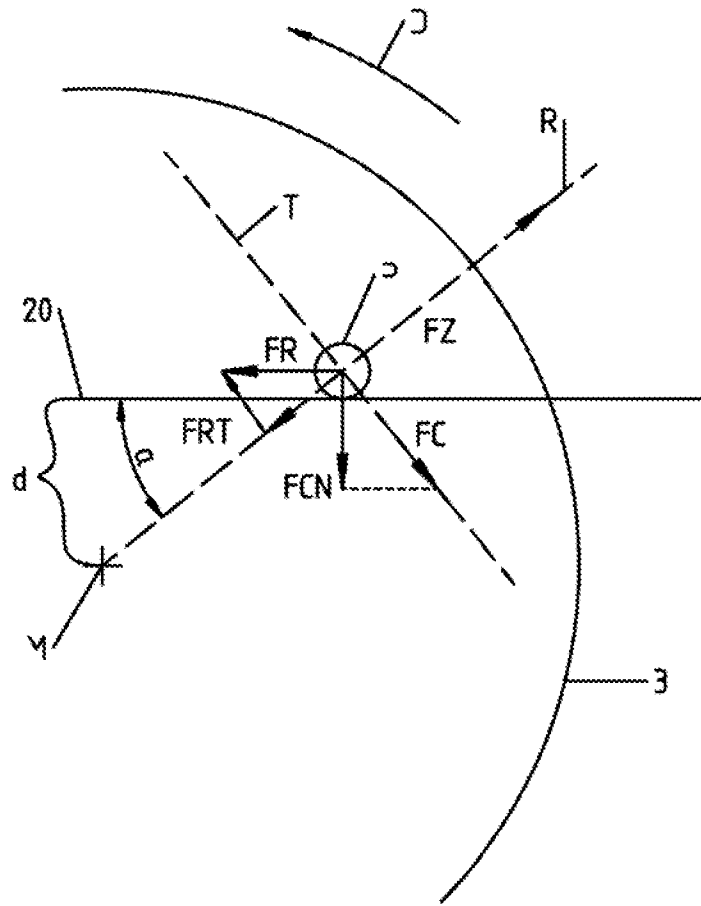

Fig. 3

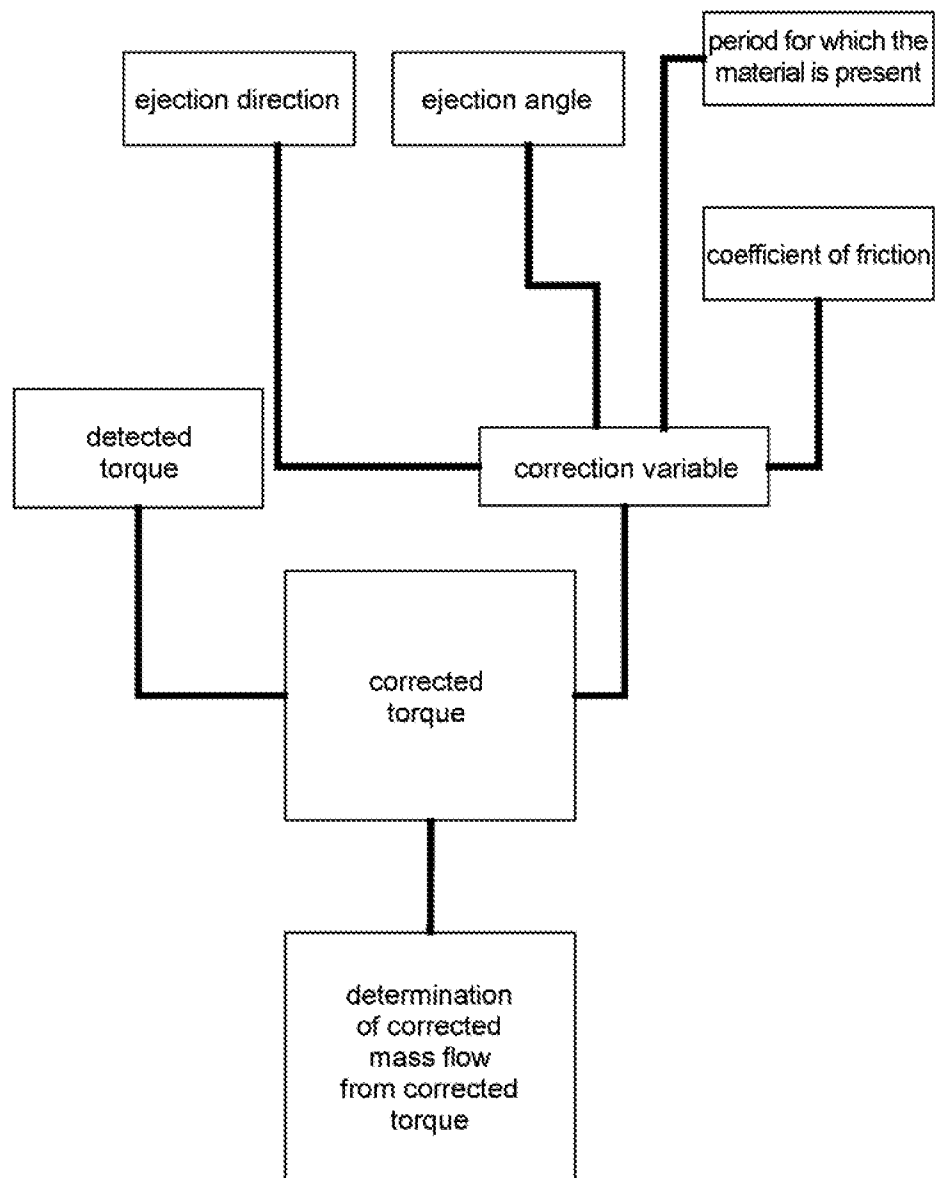

Fig. 4

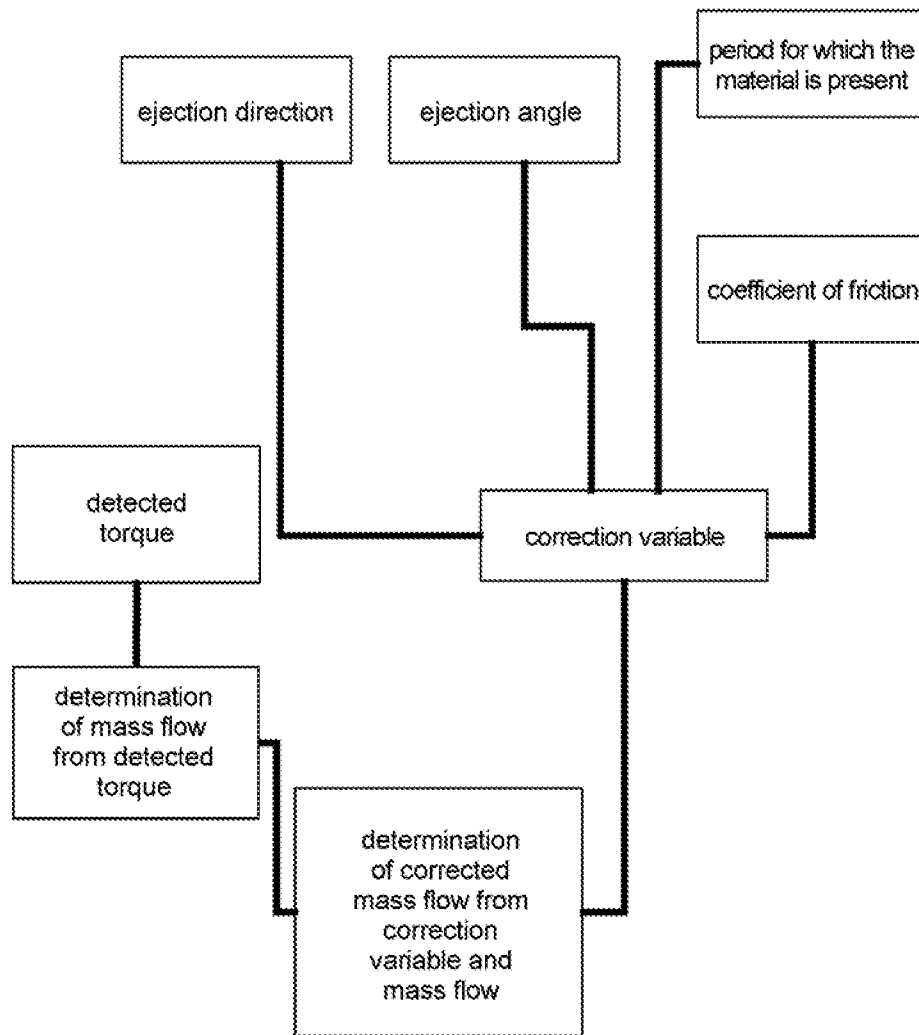

Fig. 5