

No. 685,812.

Patented Nov. 5, 1901.

F. E. BARTHOLOMEW.
ATTACHMENT FOR LOG SAWING MACHINES.

(Application filed Apr. 18, 1901.)

(No Model.)

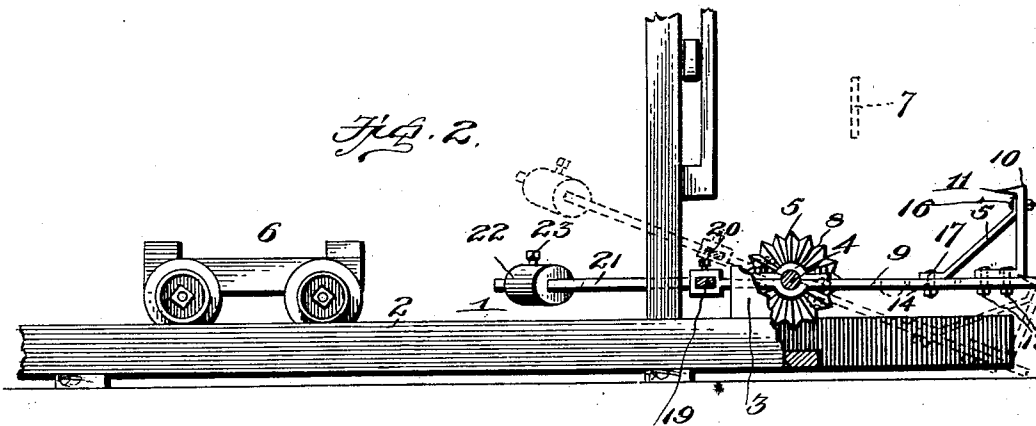
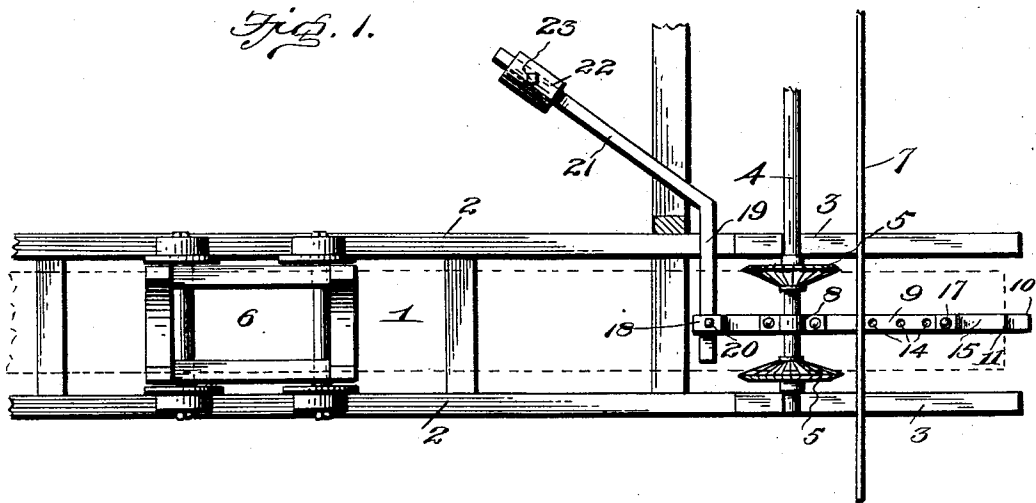

Witnesses
E. Hunt
J. Wilson

Inventor
F. E. Bartholomew
By *A. B. Wilson*
Attorneys

UNITED STATES PATENT OFFICE.

FRANK E. BARTHOLOMEW, OF KALKASKA, MICHIGAN.

ATTACHMENT FOR LOG-SAWING MACHINES.

SPECIFICATION forming part of Letters Patent No. 685,812, dated November 5, 1901.

Application filed April 18, 1901. Serial No. 56,385. (No model.)

To all whom it may concern:

Be it known that I, FRANK E. BARTHOLOMEW, a citizen of the United States, residing at Kalkaska, in the county of Kalkaska and State of Michigan, have invented certain new and useful Improvements in Attachments for Log-Sawing Machines; and I do declare the following to be a full, clear, and exact description of the invention, such as will enable others skilled in the art to which it appertains to make and use the same.

My invention relates to an attachment for sawing-machines, particularly log-sawing machines, for arresting the feed of the log as it passes beneath the saw to cut off a desired length of butt or block.

The object of the invention is to provide a simple and effective device of this character which may be adjusted to accurately gage the length of block to be cut and which is adapted to automatically dump the block and return to its normal position for further operation.

With this and other objects in view, which will appear as the nature of the invention is better understood, the invention consists of certain novel features of construction, combination, and arrangement of parts, as will be hereinafter more fully described, and particularly pointed out in the appended claims.

In the accompanying drawings, Figure 1 is a top plan view of so much of a sawing-machine as is necessary to illustrate the nature of the present invention, showing the application of the invention thereto. Fig. 2 is a side elevation and partial section thereof, illustrating the operation of the invention in full and broken lines.

Referring now more particularly to the drawings, the numeral 1 represents the carriage-frame of a sawmill of the ordinary or any approved construction, the same comprising parallel track-rails 2, suitably connected and carrying at their forward ends bearing-blocks 3, in which a transverse feed-shaft 4, carrying spur-wheels 5, which engage and feed the log forward to be cut, is rotatably mounted.

6 is the truck or carriage which supports the log and is provided with wheels or rollers to traverse the rails 2, and 7 is the saw, which may be reciprocated through the instrumen-

tality of any preferred type of mechanism and is preferably mounted so as to be raised and lowered to throw it into and out of action. The mechanism for operating the saw may be of any desired type and is not herein shown, as it forms no part of the present invention.

In carrying my invention into practice I arrange at the forward end of the carriage-frame 1 an automatic stop and gaging device, constructed as follows: Pivotaly mounted upon the feed-shaft 4 by means of a bearing 8, so as to tilt in a vertical plane, is a bar 9, which is disposed between and arranged parallel with the track-rails 2 and is provided at its outer or forward end with an adjustable stop 10, provided at its upper end with a spur or tooth 11 to retain the log in position against outward or upward movement. This stop is vertically disposed and is provided at its lower end with a foot-rest 12, adjustably connected to the bar by means of bolts 13, adapted to be passed through openings 14, formed in said bar. The stop is reinforced and braced by a diagonal brace-rod 15, secured at its upper end thereto by a bolt 16 and at its lower end to the bar 9 by means of a bolt 17, which is also adapted to be passed through one of the said openings 14. The brace-rod 15 in addition to reinforcing the stop 10 serves the further purpose of an inclined plane for facilitating the dump or discharge of the butt or block sawed off from the log, as will appear more fully hereinafter. The stop 10 and brace-rod 15 are adapted to be adjusted along the bar 9 toward and from the saw 7 to arrest the movement of the log at any desired point in advance of the saw, so as to provide for the sawing off of blocks or butts of different lengths. The bar 9 is provided at its rear end with an eye or socket 18, into which is fitted one end of a counterbalancing-lever 19, which is held within said socket by means of a set-screw 20 or any other preferred construction of fastening means. This lever is preferably disposed at right angles to the bar 9, but may have its outer end angularly projected to form a longer arm 21, so arranged as to provide for its proper connection with the bar 9 and to clear certain portions of the frame of the sawing-machine. (Not necessary to be herein shown.) On the said arm

21 of the counterbalancing-lever 19 is mounted a sliding counterweight 22, which is adapted to be secured thereto at any desired point by a set-screw 23.

5 The operation of the device is as follows: The log is supported in the usual manner upon the truck or carriage 6 and at its forward end is engaged with the spur-wheels 5 on the feed-shaft 4, which act to feed it forwardly to be
 10 operated upon by the saw 7. As the forward end of the log comes in contact with the stop 10 the motion of the log is arrested, and the saw may then be thrown into operation to cut or saw off the block or butt. Upon the
 15 severance of the block or butt from the body or remainder of the log the weight thereof causes the forward end of the bar 9 to tilt or drop downward, and thus allow the block or butt to roll off, the inclined brace 15 serving
 20 in this connection as an inclined plane to facilitate the dumping of the block. Upon the removal of the weight of the block from the bar 9 the counterbalancing-lever 19 acts to restore the bar 9 to its normal position, and
 25 the action before described is repeated, the movement of the log being automatically arrested and the blocks or butts discharged as soon as cut, so as to render the services of an attendant or the operation of grippers
 30 by the engineer entirely unnecessary. The length of the block or butt to be cut may be regulated within predetermined limits by simply adjusting the stop 10 toward or from the saw 7 and correspondingly varying the position
 35 of the counterweight 22 to compensate for the change in position of said stop, as will be readily understood. The lever 19 and counterweight 22 are so proportioned and arranged as to normally counterbalance the
 40 weight of the bar 9 and its connections, so as to maintain said bar in a horizontal position ready for operation, and by simply adjusting the weight 22, as before described, the leverage or counterbalancing action exerted by the lever 19 may be varied accordingly as the
 45 stop 10 is moved toward or from the saw, so as to insure a sensitive automatic movement of the bar 9 in tilting to discharge the block and then returning to its normal position for
 50 further operation.

From the foregoing description, taken in connection with the accompanying drawings,

the construction, mode of operation, and advantages of my invention will be manifest.

While the construction and arrangement 55 of parts herein shown are deemed preferable, it will of course be understood that changes in the form, proportion, and details of construction may be made within the scope of the invention without departing from the
 60 spirit or sacrificing any of the advantages thereof. For instance, the bar 9 instead of being pivotally connected to the shaft 4 may be similarly connected to an auxiliary shaft mounted below said shaft 4 and have its forward
 65 portion offset in such manner as to assume the normal operative position shown and described in the present instance.

Having thus described my invention, what I claim, and desire to secure by Letters Patent, 70 is—

1. In a stop and gage attachment for sawing-machines, the combination, with feed mechanism and a saw, of a tilting bar, a stop longitudinally adjustable upon one end of the bar and provided with a spur and an inclined brace serving as an inclined plane for the free discharge of the log, a lever connected with the opposite end of the bar and projecting at an angle thereto, and an adjustable
 80 counterweight carried by said lever, substantially as described.

2. In a stop and gage attachment for sawing-machines, the combination, with a trackway, and a saw reciprocating transversely
 85 thereto, of a transverse shaft mounted in bearings upon the trackway and provided with feed-wheels for feeding the log to the saw, a bar extending longitudinally between the tracks of the trackway and mounted to
 90 tilt in a vertical plane upon said shaft, a stop adjustably mounted upon one end of the bar, a counterbalancing-lever connected with the other end of the bar and extending transversely beyond one side of the trackway, and
 95 a counterweight adjustably mounted upon said lever, substantially as described.

In testimony whereof I have hereunto set my hand in presence of two subscribing witnesses.

FRANK E. BARTHOLOMEW.

Witnesses:

T. D. HOBBS,
 N. BRENT.