

(19) World Intellectual Property
Organization
International Bureau



(43) International Publication Date
3 February 2005 (03.02.2005)

PCT

(10) International Publication Number
WO 2005/009598 A1

(51) International Patent Classification⁷: **B01F 3/04**,
5/00 // A01K 61/00

[NO/NO]; Libakkvn. 1b, N-1134 Oslo (NO). **BEKKEN, Svein** [NO/NO]; Granlivn. 5d, N-3870 Langesund (NO). **ABRAHAMSEN, Roger** [NO/NO]; Prof. Lochmannsgt. 2, N-0559 Oslo (NO).

(21) International Application Number:
PCT/NO2004/000228

(74) Agent: **ANDERSON, Elin**; Yara International ASA, P.O. Box 2464 Solli, N-0202 Oslo (NO).

(22) International Filing Date: 23 July 2004 (23.07.2004)

(25) Filing Language: English

(81) Designated States (unless otherwise indicated, for every kind of national protection available): AE, AG, AL, AM, AT, AU, AZ, BA, BB, BG, BR, BW, BY, BZ, CA, CH, CN, CO, CR, CU, CZ, DE, DK, DM, DZ, EC, EE, EG, ES, FI, GB, GD, GE, GH, GM, HR, HU, ID, IL, IN, IS, JP, KE, KG, KP, KR, KZ, LC, LK, LR, LS, LT, LU, LV, MA, MD, MG, MK, MN, MW, MX, MZ, NA, NI, NO, NZ, OM, PG, PH, PL, PT, RO, RU, SC, SD, SE, SG, SK, SL, SY, TJ, TM, TN, TR, TT, TZ, UA, UG, US, UZ, VC, VN, YU, ZA, ZM, ZW.

(26) Publication Language: English

(30) Priority Data:
20033348 25 July 2003 (25.07.2003) NO

(71) Applicant (for all designated States except US): **YARA INTERNATIONAL ASA** [NO/NO]; P.O. Box 2464 Solli, N-0202 Oslo (NO).

(72) Inventors; and

(84) Designated States (unless otherwise indicated, for every kind of regional protection available): ARIPO (BW, GH,

(75) Inventors/Applicants (for US only): **EMILSEN, Morten**

[Continued on next page]

(54) Title: A METHOD AND EQUIPMENT FOR MIXING FLUIDS

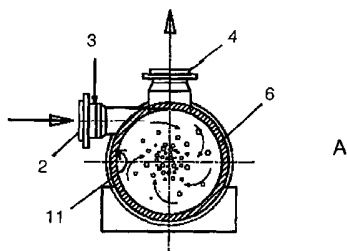

Section A-A

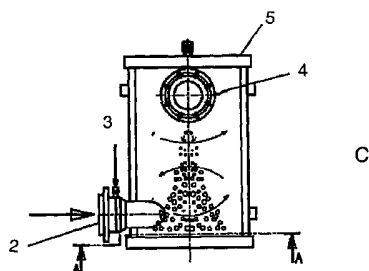
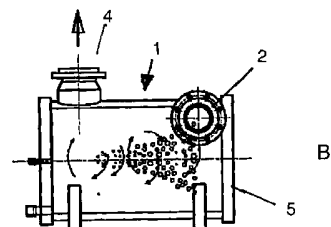

(57) Abstract: The present invention concerns a method and equipment for dissolving a gas or a gas mixture in a liquid. The liquid is introduced into a chamber (6) via an inlet (2), in connection with which an eddy movement is created in the chamber for mixing the gas and liquid. The gas may be introduced into the liquid before the liquid is introduced into the chamber and/or the gas may be introduced directly into the chamber. The liquid with the dissolved gas is removed via an outlet (4). The gas is dissolved in the liquid by the eddy rotating about a mainly horizontal axis. With the present invention, satisfactory dissolution can be achieved with minimal energy consumption. The present invention is particularly well suited to oxygenating salt water, for example in connection with fish farming.

WO 2005/009598 A1



GM, KE, LS, MW, MZ, NA, SD, SL, SZ, TZ, UG, ZM, ZW), Eurasian (AM, AZ, BY, KG, KZ, MD, RU, TJ, TM), European (AT, BE, BG, CH, CY, CZ, DE, DK, EE, ES, FI, FR, GB, GR, HU, IE, IT, LU, MC, NL, PL, PT, RO, SE, SI, SK, TR), OAPI (BF, BJ, CF, CG, CI, CM, GA, GN, GQ, GW, ML, MR, NE, SN, TD, TG).

— *before the expiration of the time limit for amending the claims and to be republished in the event of receipt of amendments*

Published:

— *with international search report*

For two-letter codes and other abbreviations, refer to the "Guidance Notes on Codes and Abbreviations" appearing at the beginning of each regular issue of the PCT Gazette.

A Method and Equipment for Mixing Fluids

5 The present invention concerns a method and equipment for dissolving gas in a liquid. In particular, the present invention concerns the dissolution of a gas in fresh water and/or salt water, where the gas may, for example, consist of oxygen or carbon dioxide.

10 The present invention may be used for oxygen enrichment of water and may thus be used in connection with the farming of fish or other beings that live in water.

US patent 4,834,343 describes a method for creating contact between a gas and a liquid. The gas and the liquid are mixed in a pipe before being passed to the top of an eddy chamber and on tangentially into it. In the eddy chamber the mixture is subject to a rotating movement around a vertical axis at the same time as another rotating flow is set up along the same axis. The downward component of the flow is further reinforced by it being possible for liquid to be introduced axially at the top of the chamber. In connection with the flows that occur, shear forces and turbulent flow are produced. They are intended to cause the size of gas bubbles in the mixture to be broken down. In order to achieve satisfactory results, liquid must be supplied to the chamber axially, as, otherwise, bubbles may be transported in towards a central area in the eddy in such a way that an inactive area is formed in the centre of the eddy with little mass transfer as a result.

25 Other disadvantages with prior art solutions for the dissolution of a gas in a liquid are that they are based on changes in direction and cross-section transitions for the flowing liquid, which will involve pressure loss and the use of additional pumps or boosters to maintain the desired pressure/volume flow, which, in turn, will entail increased costs.

30 An apparatus and method for dissolving gas in a liquid where there is a change in direction of the flow, is described in International patent application WO8101700. The apparatus has an inlet pipe for liquid communicating with the top of a vertical

generally cylindrical chamber communicating with a horizontal cylindrical main chamber. Gas and liquid is supplied to the vertical chamber where the mixing takes place. In the main chamber there is no rotation, only linear flow. Undissolved gas is collected in a chamber for recirculation. Use of a venturi nozzle in the inlet makes it
5 necessary to use of a pump in connection with the apparatus.

In US 6 382 601 it is described a swirling fine-bubble generator with conical or bottle-like shape where water and gas is added separately. The water is supplied tangentially and under pressure. A pump is necessary. A swirl is formed along the
10 central axis and the micro bubbles are formed at the outlet. It is necessary to use such a high pressure that the bubbles do not coalesce. The narrowing down of the apparatus leads to a large pressure loss that makes it necessary to utilise a much higher water pressure. The whole apparatus or at least the outlet of the apparatus must be submerged in liquid.

15

The object of the invention is to obtain a simple, robust method and equipment for dissolving gas in a liquid. Another object is to be able to utilise a low pressure water source without the need of a pump.

20 This and other objects of the invention can be obtained with the method and equipment as described below and the invention is further defined and characterised by the accompanying patent claims.

The invention thus concerns a method and equipment for dissolving a gas or a gas
25 mixture in a liquid where the liquid is introduced tangentially into a chamber creating an eddy rotating about a mainly horizontal axis. The chamber is mainly cylindrical and shaped in such a way that essential pressure loss in the chamber is avoided. The inlet and outlet of the chamber must have such a dimension that they do not cause significant pressure loss. The gas could be introduced into the liquid before the
30 liquid is introduced to the chamber or it could be introduced directly into the chamber. It is preferred that the eddy movement is such that the mixture has a helical movement. The liquid inlet is mainly horizontal and it is preferred that the outlet is arranged tangentially to the chamber. It could also be arranged centrally. The liquid with dissolved gas is preferably supplied to a tank via pipes and nozzles submerged

in the fluid in the tank, where the pressure is released. The gas is preferably oxygen or carbon dioxide and the liquid fresh water and/ or salt water.

5 The apparatus is horizontal and the micro bubbles are generated in the inlet and in the first part of the cylindrical apparatus. The rest of the space is for transport only. It is used water of low pressure and the pressure is maintained through the whole apparatus.

10 The present invention represents a simple, robust method and equipment for dissolving gas in a liquid. In accordance with the present invention, satisfactory results can be achieved for the dissolution of gas in a liquid at the same time as energy consumption is minimal. Moreover, the present invention is simple to produce and requires a minimum of connections and additional equipment to ensure stable, effective dissolution of gas in liquid.

15

The invention will be further explained with reference to the accompanying drawings, Figures 1-2, wherein:

Figure 1A shows a cross-section through the equipment at its inlet end.

20

Figure 1B shows a side view of equipment.

Figure 1C shows a top view of the equipment.

25 Figure 2 shows the equipment connected to a farming tank via a water distribution pipe and an adapted jet pipe.

30 Fig. 1A shows a cross section at its inlet end of the equipment 1 in accordance with the present invention. As this figure shows, the cross-section of the chamber is mainly circular so that the chamber's internal surface will mainly be cylindrical.

A liquid inlet 2 is provided for communication with an extended chamber 6. The chamber is located so that its axis is mainly horizontal. A gas inlet 3 is provided in connection with the liquid inlet, which is also mainly horizontal. Upstream of these

inlets for gas and liquid, there may be means for control/regulation of the quantity/pressure of the inflowing fluids (not shown). Alternatively, the gas may be introduced directly into the chamber without being mixed with the liquid in advance, or it may be introduced partly directly into the chamber and partly into the liquid flow before the chamber.

The chamber 6 may also be mounted in a frame 5, (shown in Figures 1B and C) consisting of plates, profiles or other appropriate construction materials that ensure its stable mounting. As stated above, the chamber 6 is designed as an extended body in which the inlet 2 is arranged tangentially to it.

At the downstream end of the chamber 6 is an outlet 4, see Figures 1A-C. As the figures show, the outlet extends upwards and is in a tangential or centred position in relation to the chamber 6.

In figure 2, the equipment is shown connected to a farming tank via water distribution pipes 7 and an adapted jet pipe 8, utilising existing local low-pressure water. The treated water is supplied to the tank 9 via one or more nozzles 11. As illustrated in this figure, the equipment is placed outside the farming tank, which saves valuable space in the tank and makes service easier. The whole water supply to the farming tank passes through the equipment for dissolving gas into the water. Both inlet and outlet pipes should have such a dimension that essential pressure loss is avoided.

Method of operation of the present invention:

The present invention is based on the principle that the inflowing fluid or fluid mixture (gas and liquid) sets up an eddy movement in the chamber 6. The eddy movement occurs and is supported in a relatively wide interval of flow parameters related to the inflowing fluid. Under certain conditions for the chamber's cross-section and the inlet's cross-section, the volume flow of the inflowing fluid will generally determine the flow that occurs in the chamber.

Testing has shown that an important parameter is the dimensioning of the inlet pipe. The inlet energy creates a continuous turbulent zone that consists of a cylinder that fills the entire main pipe in the first third of its length and subsequently a decreasing

cone in the next third, this is illustrated in the Figures. This rotates at a higher speed than the rest of the water and meets resistance generated partially by injected gas and partially by slip friction against the rest of the water.

5 Many forces and mechanisms occur in the turbulence zone. This is where gas is dissolved and microbubbles are generated. In the last third, the water rotates at "normal" speed in relation to the diameter and through-flowing water quantity. This is so low that a gas cylinder is not created in the centre. This becomes a transport zone towards the outlet. The outlet, in turn, is a compromise between pressure loss and a
10 reasonable flow speed to maintain the microbubbles up to the tank. The dissolving equipment is suitable for use at low pressure such as 0.3 to 1 bar.

Tests have shown that, with a volume flow that is too low, the fluid will flow into the fluid in the chamber without a dominant eddy movement being initiated. If the volume
15 flow is increased, the fluid in the chamber will gradually start to rotate and assume an eddy movement. If the volume flow is increased further, the eddy will rotate faster and faster until a gas volume is created that is located centrally and coaxially in the chamber. In the tests, the volume flow out of the chamber was equivalent to the volume flow into it. As a consequence of this, fluid was transported partly in a
20 circulating movement around the longitudinal axis of the chamber and partly downstream along this axis. Fluid will thus mainly be transported along a helix. The fluid's dwell time in the chamber will be determined by the volume flow into/out of the chamber at any time, and by the dimensions of the chamber such as diameter and length.

25

It has been shown that, by adapting the volume flow, the dimensions of the chamber and the dimensions of the inlet/outlet, it is possible to achieve very satisfactory dissolution of gas in liquid with a limited pressure loss. Among other things, tests have been carried out on the dissolution of oxygen in water with some salt content.
30 The results show that good oxygen dissolution can be achieved with low energy consumption.

In particular, it has proved possible to achieve satisfactory dissolution by creating an eddy that runs mainly from the inlet end to the outlet end. Moreover, it has been

shown that this eddy is supported in a relatively wide interval of flow-determining parameters, while a centrally, coaxially located gas pocket can be avoided completely or partially.

- 5 The diameters for inlet pipes, chamber, outlet pipes, jet pipe and nozzles should be of such a dimension that coalescence is avoided and that too high pressure loss is avoided. In the nozzles the flow must be so high that the pressure is released and that any large bubbles are broken down to micro bubbles. A minimum speed must be maintained at the outlet of the nozzles, in such a way that the micro bubbles are
10 distributed 1-2 m horizontally.

In the inlet to the chamber the flow rate must be high enough to create the necessary rotation, but not so high that pressure loss and separation of gas/fluid is the result. In the chamber the total flow rate must be low enough to ensure the necessary
15 retention time, but not so low that the gas is separated out at the top of the chamber.

Typical flow rates are as follows:

- | | |
|-------------------------------|---|
| Inlet to chamber: | 2-3 m/s |
| Chamber: | about 0.2 m/s in the horizontal direction |
| 20 Outlet pipes and jet pipe: | 2-2.5 m/s |
| Within nozzle: | 4-10 m/s (at pressures 0.3-1 bar) |
| Outlet from nozzle: | 1 – 1.5 m/s |

The physical phenomena that occur in connection with the dissolution of gas in liquid
25 in accordance with the present invention are assumed to be a result of the fact that the gas that is introduced with the liquid into the chamber in the form of bubbles will primarily, on account of its buoyancy in the liquid, be moved up towards the cylindrical surface 11 of the chamber almost immediately after entering the chamber. Since the flow is deflected continuously on account of the curvature of the internal
30 surface 11, shear and compressive forces will occur in the fluid, causing the liquid to compress the gas bubbles and divide them into more smaller bubbles, thus creating a greater contact area between the gas and liquid.

Another effect is that, in the boundary surface between the internal surface 11 and the fluid, the bubbles that are located there will have one side facing the stationary surface 11 and one side in the flowing fluid. This will cause the creation of shear forces that tear the bubbles up into smaller bubbles. This corresponds to the established theory in fluid mechanics that shear forces occur in the boundary layer between a flow and a stationary guide surface on account of different speed vectors in this layer.

Bubbles that are not immediately dissolved in the liquid will, along the helical flow path, tend to rise vertically upwards because the gas bubbles have greater buoyancy than the surrounding liquid. This causes undissolved gas bubbles to be lifted up towards the upper half of the internal surface 11 and in towards the boundary surface or boundary layer between the flowing fluid and the stationary surface 11. As described above, bubbles that occur there will be torn/crushed into smaller bubbles by the interaction between the flowing fluid and the surface.

Derived from the above principle, the surface 11 may expediently be designed with a roughness or smaller deviation from a smooth surface in order to reinforce its affinity to the bubbles and further improve the conversion of large bubbles into smaller bubbles.

The present invention has proved to be particularly well suited for dissolving oxygen in salt water and thus has an important application in connection with farming beings that live in salt water such as salt-water fish. The present invention is particularly well suited to land-based farming of salt-water fish in farming tanks.

The dissolving equipment is particularly well suited to mixing oxygen into salt water at low pressure, but also functions with carbon dioxide in fresh water (because CO₂ is much easier to dissolve in water than oxygen).

The dissolving equipment can be said to be a combination of dissolving equipment and a microbubble generator. It utilises the fact that it is relatively easy to create microbubbles or floating bubbles of oxygen in salt water (they assume a modified surface tension on account of the salt). Unlike "normal" bubbles, these bubbles follow

the water flow without rising or merging as soon as the speed and transport length are correctly adjusted.

5 The proportion of gas that constitutes microbubbles varies from 5% at low load to approximately 30% at full oxygen supply. These microbubbles are transported up into the farming tank with an adapted jet pipe and will dissolve in the undersaturated water in the tank.

10 There will be a certain amount of loss (to the surface) in this process, which has the favourable effect of stripping out undesired gases such as nitrogen and carbon dioxide, but which naturally reduces oxygen efficiency.

15 Experiments have shown that the total oxygen utilisation of the present invention is 80 to 95% (depending on the depth and water rotation speed of the farming tank).

In Table 1 it is shown results from experiments carried out with salt-water and oxygen in a farming tank.

20

Table 1

RAW WATER					DOSED O ₂		ANALYSED O ₂		
O ₂ mg/l	O ₂ % sat.	T [°C]	P [barg]	Q [l/min]	kg/h	mg/l	mg/l	% sat.	% eff.
9,48	81,7	9,7	0,3	460	0,322	11,7	20,5	178	94,0
9,80	88	11,4	0,3	410	0,322	13,1	20,2	181	79,4

25

Claims

1. A method for dissolving a gas or a gas mixture in a liquid in which the liquid is introduced into a chamber (6) via an inlet (2), in connection with which an eddy movement is created in the chamber for mixing the gas and liquid, and in which
5 the gas is introduced into the liquid before the liquid is introduced into the chamber and/or the gas is introduced directly into the chamber, after which the liquid with the dissolved gas can be removed via an outlet (4),
c h a r a c t e r i s e d i n t h a t
10 the liquid is introduced into the chamber (6) tangentially creating an eddy rotating about a mainly horizontal axis in a mainly cylindrical chamber shaped in such a way that essential pressure loss in the chamber is avoided.
2. A method in accordance with claim 1,
15 c h a r a c t e r i s e d i n t h a t
the eddy movement is such that the mixture has a helical movement.
3. A method in accordance with claim 1,
c h a r a c t e r i s e d i n t h a t
20 the liquid is introduced via a mainly horizontal inlet (2).
4. A method in accordance with claim 1,
c h a r a c t e r i s e d i n t h a t the liquid with dissolved gas is supplied to a tank
via pipes (7, 8) and nozzles (10) submerged in the fluid in the tank, where the
25 pressure is released.
5. A method in accordance with claim 1,
c h a r a c t e r i s e d i n t h a t
the gas is oxygen or carbon dioxide.
30
6. A method in accordance with claim 1,
c h a r a c t e r i s e d i n t h a t
the liquid is fresh water and/or salt water.

7. A method in accordance with claim 1,
characterised in that
the pressure of the liquid is 0.3 – 1 bar.
- 5 8. Equipment for dissolving a gas or a gas mixture in a liquid, comprising a chamber
(6) with an inlet (2) for liquid and gas (3) and an outlet (4) for liquid with dissolved
gas,
characterised in that
the chamber (6) is cylindrical around a mainly horizontal axis and where the inlet
10 (2) is arranged tangentially in relation to the chamber (6).
9. Equipment in accordance with claim 8,
characterised in that
the inlet (2) is located mainly along a horizontal axis.
- 15 10. Equipment in accordance with claim 8,
characterised in that
the outlet (4) is arranged tangentially in relation to the chamber.
- 20 11. Equipment in accordance with claim 8,
characterised in that
the outlet (4) extends vertically upwards.
12. Equipment in accordance with claim 8,
25 characterised in that
the inlet (2) and outlet (4) of the chamber is of such a dimension that they do not
cause essential pressure loss.
13. Equipment in accordance with claim 8,
30 characterised in that
the outlet (4) of the chamber (6) is connected to a jet pipe (8) with nozzles (10)
adapted to be submerged in liquid, for supply of liquid with dissolved gas to a
tank.

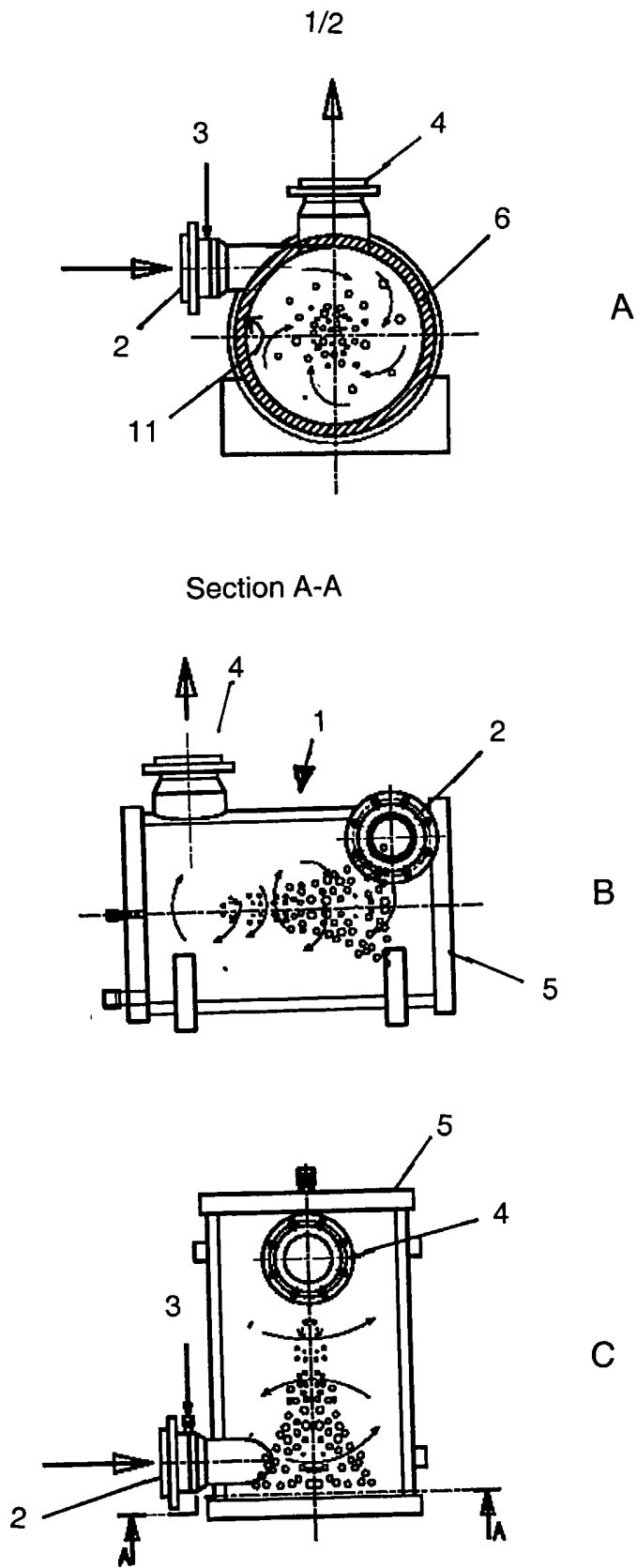

Figure 1

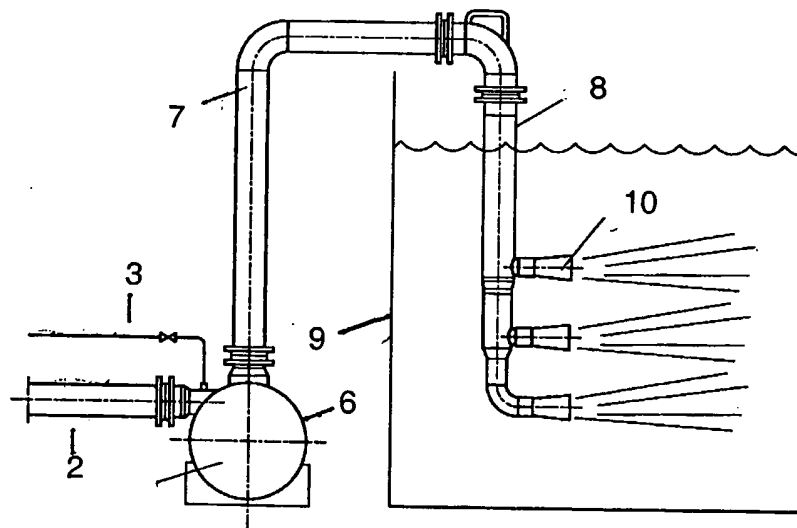

Figure 2

INTERNATIONAL SEARCH REPORT

International application No.
PCT/NO 2004/000228

A. CLASSIFICATION OF SUBJECT MATTER

IPC7: B01F 3/04, B01F 5/00 // A01K 61/00
According to International Patent Classification (IPC) or to both national classification and IPC

B. FIELDS SEARCHED

Minimum documentation searched (classification system followed by classification symbols)

IPC7: A01K, B01F

Documentation searched other than minimum documentation to the extent that such documents are included in the fields searched

SE,DK,FI,NO classes as above

Electronic data base consulted during the international search (name of data base and, where practicable, search terms used)

EPO-INTERNAL, WPI DATA

C. DOCUMENTS CONSIDERED TO BE RELEVANT

Category*	Citation of document, with indication, where appropriate, of the relevant passages	Relevant to claim No.
X	EP 1112773 A1 (OHNARI, HIROFUMI TOKUYAMA-SHI), 4 July 2001 (04.07.2001), page 3, line 5 - line 7; page 3, line 11 - line 14; page 5, line 15 - line 19, figures 1a, 5a --	1-2,4-8, 10-13
X	GB 1570202 A (CHARLES EDWARD TRAVERSE), 25 June 1980 (25.06.1980), page 1, line 11 - line 17; page 4, line 87 - line 102; page 5, line 35 - line 43, figure 1 --	1,2,5,6,8,12
A	US 6382601 B1 (HIROFUMI OHNARI), 7 May 2002 (07.05.2002), figures 12 a -----	1-13

Further documents are listed in the continuation of Box C. See patent family annex.

<p>* Special categories of cited documents:</p> <p>"A" document defining the general state of the art which is not considered to be of particular relevance</p> <p>"E" earlier application or patent but published on or after the international filing date</p> <p>"L" document which may throw doubts on priority claim(s) or which is cited to establish the publication date of another citation or other special reason (as specified)</p> <p>"O" document referring to an oral disclosure, use, exhibition or other means</p> <p>"P" document published prior to the international filing date but later than the priority date claimed</p>	<p>"T" later document published after the international filing date or priority date and not in conflict with the application but cited to understand the principle or theory underlying the invention</p> <p>"X" document of particular relevance: the claimed invention cannot be considered novel or cannot be considered to involve an inventive step when the document is taken alone</p> <p>"Y" document of particular relevance: the claimed invention cannot be considered to involve an inventive step when the document is combined with one or more other such documents, such combination being obvious to a person skilled in the art</p> <p>"&" document member of the same patent family</p>
---	---

Date of the actual completion of the international search 7 December 2004	Date of mailing of the international search report 08-12-2004
---	---

Name and mailing address of the ISA/ Swedish Patent Office Box 5055, S-102 42 STOCKHOLM Facsimile No. +46 8 666 02 86	Authorized officer Bengt Christensson/MP Telephone No. +46 8 782 25 00
--	--

INTERNATIONAL SEARCH REPORT

Information on patent family members

30/10/2004

International application No.

PCT/NO 2004/000228

EP	1112773	A1	04/07/2001	AU	4613200	A	05/12/2000
				TW	471980	B	00/00/0000
				WO	0069550	A	23/11/2000

GB	1570202	A	25/06/1980	US	4002561	A	11/01/1977

US	6382601	B1	07/05/2002	AU	770174	B	12/02/2004
				AU	3801099	A	18/01/2001
				BR	9904494	A	06/03/2001
				CN	1256642	T	14/06/2000
				EP	0963784	A	15/12/1999
				JP	3397154	B	14/04/2003
				JP	2000000447	A	07/01/2000
				JP	2003181259	A	02/07/2003
				JP	2003205228	A	22/07/2003
				NZ	336632	A	27/10/2000
				SG	93836	A	21/01/2003
				TW	452502	B	00/00/0000
				WO	9933553	A	08/07/1999
				CA	2282326	A	08/07/1999
