

(19) **DANMARK**

(10) **DK/EP 3373778 T3**



(12) **Oversættelse af  
europæisk patentskrift**

Patent- og  
Varemærkestyrelsen

- 
- (51) Int.Cl.: **A 47 J 31/20 (2006.01)**
- (45) Oversættelsen bekendtgjort den: **2020-03-30**
- (80) Dato for Den Europæiske Patentmyndigheds bekendtgørelse om meddelelse af patentet: **2020-01-01**
- (86) Europæisk ansøgning nr.: **16790985.2**
- (86) Europæisk indleveringsdag: **2016-11-02**
- (87) Den europæiske ansøgnings publiceringsdag: **2018-09-19**
- (86) International ansøgning nr.: **EP2016076423**
- (87) Internationalt publikationsnr.: **WO2017080885**
- (30) Prioritet: **2015-11-11 DE 102015119406**
- (84) Designerede stater: **AL AT BE BG CH CY CZ DE DK EE ES FI FR GB GR HR HU IE IS IT LI LT LU LV MC MK MT NL NO PL PT RO RS SE SI SK SM TR**
- (73) Patenthaver: **PI-Design AG, Kantonsstrasse 100, 6234 Triengen, Schweiz**
- (72) Opfinder: **BODUM, Jürgen, Käppelistrasse 15, 6045 Meggen, Schweiz**
- (74) Fuldmægtig i Danmark: **Zacco Denmark A/S, Arne Jacobsens Allé 15, 2300 København S, Danmark**
- (54) Benævnelse: **Opsamlingsbeholder til opsamling af uopløseligt materiale, som anvendes ved tilberedning af drikkevarer, samt brygningsindretning med en opsamlingsbeholder af denne art**
- (56) Fremdragne publikationer:  
**EP-A1- 2 798 985**  
**WO-A1-02/067739**  
**FR-A- 1 557 460**



## Description

The present invention relates to a collection receptacle for collecting insoluble material that is used for preparing beverages by means of an infusion device. The invention also  
5 relates to an infusion device with such a collection receptacle.

Infusion devices for preparing beverages are also called French presses or filter presses. The infusion device has a container with an open end and a closed end, wherein the container typically has a cylindrical or prismatic shape. For preparing coffee  
10 or tea, the desired amount of insoluble material, such as ground coffee or tea leaves, is filled into the container and then hot water is poured over this material. Then the ground coffee or tea leaves steep for a certain amount of time. Then a piston-filter arrangement that has a piston rod and a filter press attached to the piston rod is inserted into the container. Typically, the piston rod is mounted movably in a cover that is placed on the  
15 open end and with which the container can be closed and sealed. The filter press has a shape corresponding to the cross section of the container, so that the filter press forms a seal with the container on the side. The filter press is pressed by means of the piston rod toward the closed end. In this way, the extracted ground coffee or the extracted tea leaves are separated from the coffee or tea and compressed in the area of the closed  
20 end. The filtered coffee or tea can now be drunk. After the coffee or tea has been completely consumed, the piston-filter arrangement is pulled out from the container and the compressed ground coffee or the compressed tea leaves are removed from the container.

25 Depending on how much ground coffee or tea leaves have been used, these can be compressed rather strongly, so that their removal from the container and the cleaning of the container can be rather laborious. In many cases, the ground coffee and the tea leaves are removed with the use of water and then put down the drain, which can lead to clogged drainage pipes.

30 Collection receptacles have been proposed to counteract this disadvantage. DE 34 32 289 C1, WO 02/067739 A1, EP 2 798 985 A1, and WO 96/035360 A1 disclose collection receptacles or collection plates that are inserted into the container before the

insoluble material and the water are filled into the container. When the filter press of the piston-filter arrangement is pressed toward the closed end of the container, the insoluble material collects in the collection receptacle. In addition, the piston-filter arrangement is coupled with the collection receptacle when the filter press is pressed  
5 downward, so that the collection receptacle can be pulled out from the container together with the piston-filter arrangement. This configuration significantly simplifies the cleaning of the container. In addition, the collection receptacle can be emptied into a trash can, so that the amount of insoluble material going down the drain can be significantly reduced, and clogs can be prevented.

10

For the infusion devices that are described in WO 96/035360 A1 and DE 34 32 289 C1, the piston-filter arrangement is coupled with the collection receptacle such that the filter press is inserted into the collection receptacle. Here, the coupling in WO 96/035360 A1 is created by a friction fit between the filter press and the collection receptacle, while in  
15 DE 34 32 289 C1 the collection receptacle has locking means that interact with the filter press and provide a positive fit. WO 02/067739 A1 and EP 2 798 985 A1 disclose collection plates that are coupled with the filter press by means of a positive fit. FR 1 557 460 A discloses a vessel with which the insoluble material can be immersed in a container. A press filter is not used there.

20

In particular, if a relatively large amount of insoluble material has been used, the insoluble material must be compressed so that the filter press can be inserted into the collection receptacle, which can require a relatively large amount of force. The greater the expended force, the stronger the insoluble material is compressed, which blocks the  
25 filter press starting at a certain degree of compression. Consequently, a force is applied to the water surrounding the compressed material, because it can no longer flow through the filter press. The water then searches for other ways, for example, through the contact surface between the container and the filter press, to equalize the corresponding pressure. But because the filter press is somewhat pre-tensioned against  
30 the container, a correspondingly large force must be applied to the water in order to overcome the contact surface. If the corresponding pressure is exceeded, a portion of the water suddenly flows through the contact surface, which can lead to short-term, wave-like movements of the water in the container, by means of which a portion of the

water can splash out of the container. The corresponding pressure and the force to be applied by the user for this purpose are difficult to predict, however, which can make the operation of the infusion device difficult.

5 The problem of the present invention is therefore to indicate a collection receptacle and an infusion device of the type described above, with which the disadvantages specified above are counteracted. In particular, the coupling of the collection receptacle with the piston-filter arrangement can be created with little expenditure of force, even if a greater amount of insoluble material is used. In addition, sudden, wave-like movements of the  
10 water or of the beverage while pressing down on the filter press should be prevented.

This problem is solved with the features specified in Claims 1 and 11. Advantageous embodiments are the subject matter of the dependent claims.

15 One embodiment of the invention relates to a collection receptacle for collecting insoluble material that is used for preparing beverages by means of an infusion device, wherein the infusion device comprises a container with an open end and a closed end for holding the beverage and the insoluble material and a piston-filter arrangement that can be inserted into the container via the open end and can be moved toward the  
20 closed end, wherein the collection receptacle can be inserted into the container and has a wall that forms an opening enclosed by an edge and at least one first coupling element that can be coupled with at least one second coupling element of the piston-filter arrangement such that, in the coupled state, a distance is formed between the edge of the collection receptacle and the piston-filter arrangement, where the first  
25 coupling element is arranged on a central projection of the collection receptacle and the central projection extends past the edge.

In the scope of this application, a piston-filter arrangement should be understood as the following: the piston-filter arrangement comprises a filter press that can be made, for  
30 example, from a fine-pore mesh made from metal and is fastened to a piston rod. The filter press can be arranged, for example, between two plates, in order to form it into the desired shape and hold it in this shape. The plates have corresponding holes, in order to not prevent the flow of liquid through the filter press. The plates are shaped so that

the filter press covers the entire cross section of the container and contacts the side wall of the container.

5 As already described, the collection receptacle is inserted into the container before the insoluble material and the water are filled into the container. After the water and the insoluble material have had sufficient time to interact with each other, the filter press is pressed toward the closed end of the container by means of the piston rod, so that the insoluble material is separated from the water and the filter press is coupled with the collection receptacle. The coupling elements can be designed, for example, so that the  
10 coupling is created by means of a friction fit or by means of a magnetic interaction.

According to the invention, a distance remains between the edge of the container and the piston-filter arrangement, when the collection receptacle is coupled with the piston-filter arrangement. Thus, in the coupled state, the position of the filter press relative to  
15 the collection receptacle is clearly defined. In this way it is prevented that the insoluble material is compressed too strongly, especially when a larger amount of material is used. The force that is necessary to couple the piston-filter arrangement with the collection receptacle is kept small in this way. Excessive loading of the piston-filter arrangement and especially the piston rod and the filter press is hereby prevented. It is  
20 also prevented that a portion of the water that surrounds the compressed insoluble material flows suddenly through the contact surface between the filter press and the container and thus creates a wave-like movement of the water in the container and a resulting splashing of the water out of the container. The operation of the infusion device is hereby made easier and safer.

25 The first coupling element is here arranged on a central projection of the collection receptacle. A central projection is simple to produce, because the collection receptacle can have a rotationally symmetric shape. It also does not require a large volume of space, so that the capacity of the collection receptacle for holding the insoluble material is barely reduced. In addition, the central projection disturbs the flow of water that  
30 surrounds the insoluble material practically not at all, so that the wave-like movements described above do not occur as is known from the prior art. Furthermore, the coupling between the collection receptacle and the piston-filter arrangement can be created with

only one first and one second coupling element, which simplifies the production and keeps it convenient.

5 The central projection extends past the opening outward or upward. By means of the length of the central projection, the distance between the edge and the piston-filter arrangement in the coupled state can be selected with low production expense.

10 According to the invention the central projection surrounds a hollow space. In principle, the central projection can have a solid construction, but material and weight can be saved by providing a hollow space, without reducing the stability of the central projection too much compared with a solid construction. In addition, a solid projection could lead to non-uniform cooling, which could lead to sink marks. The originally intended shape of the projection then could no longer be guaranteed. The hollow space could also taper conically toward the free end, which simplifies removal of the die.

15 According to the invention the first coupling element comprises a coupling opening in the hollow space on a free end of the central projection. The second coupling element can interact with the coupling opening for coupling the collection receptacle with the piston-filter arrangement, in particular, such that the second coupling element is guided  
20 through the coupling opening. The coupling opening can be easily produced and can be made, e.g., in the injection molding method or they can be produced at a later time with a relatively simple drilling process.

25 According to the invention it is provided that the coupling opening tapers conically viewed from the free end. As already mentioned, the coupling of the collection receptacle with the piston-filter arrangement can be created such that the second coupling element is guided through the coupling opening. The conical tapering here realizes a centering process, so that the coupling can be achieved without a problem, even if the first and the second coupling element are not oriented exactly flush with  
30 each other. With the selection of the magnitude of the tapering, the stability of the coupling opening can be increased. In this way it can also be determined how rigidly the filter-piston arrangement is coupled with the collection receptacle and what force is needed for detaching the piston-filter arrangement from the collection receptacle.

Another embodiment distinguishes itself in that the central projection has a first height and the collection receptacle has a second height at the edge and the central projection extends with a height difference between 1 mm and 8 mm and in particular between 2  
5 mm and 6 mm past the edge. The height difference is given from the difference between the first height and the second height, which defines the distance between the edge and the piston-filter arrangement in the coupled state. It has been shown that the previously mentioned splashing can be prevented in an especially effective way if the height difference is in the specified range. If the height difference is selected too large,  
10 the portion of the insoluble material that is located in the coupled state between the edge and the piston-filter arrangement and is not held by the collection receptacle is too big. This portion can be dispensed uncontrollably when pulling out the collection receptacle coupled with the piston-filter arrangement, which can result in undesired soiling. If the height difference is within the specified range, the risk that this portion is  
15 dispensed uncontrollably is relatively low.

According to another embodiment, the collection receptacle has a diameter and the ratio of the height difference to the diameter is between 0.01 and 0.07 and, in particular, between 0.02 and 0.06. The tendency for splashing generally increases with decreasing  
20 diameter, because due to the decreasing surface area of the opening, the pressure applied by the piston-filter arrangement in the collection receptacle is increased. If this ratio is in the specified range, the already described uncontrolled splashing is effectively prevented.

25 According to another embodiment, the central projection has at least one recess that starts from the free end and penetrates through the wall. With the recess, the projection is selectively weakened in the area of the free end, where the first coupling element is also arranged, so that the coupling opening can widen somewhat when the second coupling element is guided through. It is provided to produce the collection receptacle  
30 from an elastically deformable plastic, such as Tritan or POM (polyoxymethylene), so that the coupling opening pulls itself back together again to the original size after the widening. With the dimensioning of the recess, the force that is needed for widening the coupling opening can be influenced selectively.

According to another embodiment, the central projection is formed by the wall. Consequently, the projection can be constructed as an integral component of the collection receptacle and does not have to be connected to the rest of the collection  
5 receptacle as a separate part in an additional processing step. In this way, the production of the collection receptacle according to the proposal is significantly simplified.

In a refined embodiment, the wall forms a base area and a side area, where the wall in  
10 the side area runs approximately perpendicular to the base area. In this way, a relatively optimal use of space is achieved, so that the collection receptacle can provide a relatively large volume for holding the insoluble material with a relatively low use of materials. The provided volumes are, e.g., between 5 and 25 cm<sup>3</sup>, so that a sufficiently large volume is provided for holding the quantity of insoluble material, such as ground  
15 coffee or tea leaves, typically used for preparing a beverage. The designation “approximately perpendicular” should be understood to mean that one should try to arrange the side area as perpendicular to the base area as possible. However, for removing from the injection molding tool without a problem and without damage, it is necessary to let the side area be slightly conical. Depending on the plastic that is being  
20 used, the angle between the base area and the side area deviates between 0.5 and 2.5° from a right angle.

In an alternative embodiment, the collection receptacle has a number of passage  
25 openings. The passage openings must be designed so that produce a separation of the water from the compressed insoluble material within the collection receptacle, by means of which water can be removed from the compressed insoluble material. Removing the water prevents water from dripping out of the collection receptacle uncontrollably during the cleaning process. This also prevents too high a pressure from building up in the collection receptacle when the insoluble material is compressed with the piston-filter  
30 arrangement. This configuration also simplifies the coupling of the collection receptacle with the piston-filter arrangement.

One construction of the invention relates to an infusion device for preparing beverages, comprising a container with an open end and a closed end for holding the beverage and the insoluble material, a piston-filter arrangement that can be inserted into the container via the open end and can be moved toward the closed end, and a collection receptacle  
5 that can be inserted into the container, in particular, according to one of the previously described embodiments, which can be coupled with the piston-filter arrangement, wherein, in the coupled state, a distance is formed between the collection receptacle and the piston-filter arrangement. The technical effects and advantages that can be achieved with the infusion device according to the proposal correspond to those that  
10 have been explained for the collection receptacle according to the proposal. In summary, it should be noted that a collection receptacle with an infusion device according to the proposal can be connected to the piston-filter arrangement with significantly less expenditure of force in comparison with infusion devices known from the prior art, without producing uncontrolled, wave-like movements within the water,  
15 which significantly reduces the likelihood that the water will splash uncontrollably out of the container.

In another embodiment, the distance between the edge and the piston-filter arrangement is between 3 and 10 mm, in particular, between 4 and 6 mm. It has been  
20 shown to be advantageous to select the distance within this range. On one hand, the volume of the filtered beverage is not limited too much and, on the other hand, it is guaranteed that the insoluble material is not compressed too strongly and thus the collection receptacle can be coupled with the piston-filter arrangement and separated from each other again without a great expenditure of force. Especially in combination  
25 with the spherical or cylindrical section, it is guaranteed with this distance that the collection receptacle can be rotated relative to the piston-filter arrangement in a sufficient extent, without collisions.

In another embodiment, the first coupling element and the second coupling element  
30 comprise positive-locking means that interact with each other in the coupled state. The use of positive-locking means has the advantage that relatively expensive materials that are questionable for reasons of food safety, for example, magnetic or magnetizable materials, are no longer necessary. Compared with a coupling using a friction fit, the

positive-locking means have increased reliability. With the methods available today for shaping, for example, injection molding, it is possible without great expense to form the coupling elements accordingly. In addition, the positive-locking means can be constructed so that clear feedback can be given to the user when the collection  
5 receptacle is coupled with the piston-filter arrangement, for example, by a perceptible latching.

One embodiment is distinguished in that the first coupling element or the second coupling element comprises an essentially spherical or cylindrical section that is  
10 surrounded in the coupled state by locking arms of the other respective coupling element. The spherical or cylindrical section provides a back-cut section in which the locking arms can engage. In this embodiment, the collection receptacle can rotate relative to the piston-filter arrangement at least about one axis. This configuration significantly simplifies the detachment of the collection receptacle from the piston-filter  
15 arrangement after the infusion device is used, because the user can move the collection receptacle into a favorable position relative to the piston-filter arrangement. In particular, if the coupling elements are arranged on the central projection, the angle of rotation with which the collection receptacle can be rotated with respect to the piston-filter arrangement is relatively large and increases with increasing distance between the  
20 edge and the filter press. The greater the angle of rotation, the easier it is for the user to separate the collection receptacle from the piston-filter arrangement.

Example embodiments of the invention are explained in more detail below with reference to the enclosed drawings. Shown are

25

Figure 1a) a principle illustration of a lower part of an infusion device with a collection receptacle according to the state of the art, in the not coupled state,

30

Figure 1b) the infusion device shown in Figure 1a) in the coupled state,

Figure 2 a section illustration of a lower part of an infusion device with a collection receptacle according to the proposal according to a first embodiment in the coupled state,

5 Figure 3a) a section illustration through a second embodiment of the collection receptacle according to the proposal, and

Figure 3b) a perspective illustration of the collection receptacle shown in Figure 3a).

10 In Figures 1a) and 1b), the lower part of an infusion device 10P with a collection receptacle 12 according to the prior art is shown. The collection receptacle 12 is formed essentially by a wall 14 and has an opening 16 that is enclosed by an edge 18.

The infusion device 10P comprises an essentially cylindrical container 20 with a longitudinal axis L and with an open end 22 and a closed end 24. The infusion device 15 10P further comprises a piston-filter arrangement 26 that has a piston rod 28 and a filter press 30 attached to this rod. The filter press 30 is fixed to an upper plate 32 (not shown here, see Figure 2) arranged above the filter press 30 and a lower plate 34 arranged under the filter press 30 so that the filter press 30 contacts the container 20 on the side, 20 by means of which a side contact surface 36 is formed.

For preparing a beverage, first the collection receptacle 12 is inserted into the container 20, so that it contacts the closed end 24 of the container with the section of the wall 14 that is opposite the opening 16. The collection receptacle 12 must be dimensioned so 25 that it also nearly contacts the container 20 on the side, but a certain gap must be provided, in order to prevent the collection receptacle 12 from becoming stuck in the container 20. Then a certain amount of an insoluble material 37, for example, ground coffee or tea leaves, are placed in the container and water, typically hot water, is poured over this material. Here, the poured insoluble material 37 is distributed essentially 30 uniformly inside the container 20. After the insoluble material 37 has been allowed to interact with the water for the desired amount of time, the piston-filter arrangement 26 is inserted into the container 20 via the open end 22 and the filter press 30 is pressed by means of the piston rod 28 along the longitudinal axis L toward the closed end 24 of the

container 20 (see Figure 1a)). The farther the filter press 30 is pressed toward the closed end 24 of the container 20, the more the insoluble material 37 is compressed and moved toward the collection receptacle 12. Starting from a certain position of the filter press 30, this is immersed with the lower plate 34 into the collection receptacle 12 (see Figure 1b)). Depending on the construction of the filter press 30 and the collection receptacle 12, the coupling is created by means of a friction fit between the filter press 30, here essentially with the lower plate 34, and the inner surface of the collection receptacle 12, as shown in Figure 1b), or by means of a positive fit between the filter press 30, in particular, the lower plate 34, and the collection receptacle 12, wherein, in the latter case, corresponding connection elements can be provided (not shown). In both cases, a prerequisite for the coupling is that the filter press 30 is inserted at least partially into the collection receptacle 12.

If, however, the quantity of the insoluble material 37 is selected to be very large, for example, in order to prepare especially strong coffee, the collection receptacle 12 is very quickly filled to a large extent with the insoluble material 37. In order to nevertheless create a coupling, the filter press 30 must be inserted into the collection receptacle 12 with an increased expenditure of force against the compressed insoluble material 37, which leads, on one hand, to strong loading especially of the piston rod 28 and, on the other hand, is difficult for the user. Furthermore, the filter press 30 can become blocked by the insoluble material 37, so that the water cannot flow through the filter. If the user applies a correspondingly high force, a portion of the water flows abruptly from the area located below the filter press 30 with respect to the diagram shown in Figures 1a) and 1b) through the contact surface 36 into the area above the filter press 30, by means of which wave-like movements can be generated in the water and a portion of the water can splash out of the container 20.

After the beverage has been prepared and consumed and the collection receptacle 12 is to be separated from the filter press 30, the position of the piston-filter arrangement 26 cannot be changed relative to the collection receptacle 12, and in particular, the piston-filter arrangement 26 cannot be rotated relative to the collection receptacle 12, because then the filter press 30 would be out of alignment in the collection receptacle

12 and the insoluble material 37 would have to be compressed more at least on one side. This makes the separation process more difficult.

5 In Figure 2, an infusion device 10 according to the proposal is shown with reference to a section drawing, wherein the collection receptacle 12<sub>1</sub> according to a first embodiment is coupled with the piston-filter arrangement 26. The infusion device has essentially the same basic construction as the infusion device 10 shown in Figures 1a) and 1b). Also shown is the diameter DC of the container 20.

10 In contrast to the collection receptacle that is known from the prior art and is shown in Figures 1a) and 1a), the collection receptacle 12<sub>1</sub> according to the proposal has a central projection 38 rising from a base area 56 of the collection receptacle 12<sub>1</sub> in a column-like shape about the longitudinal axis L, where this projection is formed by the wall 14, has a free end 41, and encloses a hollow space 39. On the central projection  
15 38 there is, on its free end 41, a first coupling element 40 that interacts, for coupling the collection receptacle 12<sub>1</sub> with the piston-filter arrangement 26, with a second coupling element 42 of the piston-filter arrangement 26, which is arranged approximately below the filter press 30 and the lower plate 34. In the shown example, the first coupling element 40 and the second coupling element 42 have positive-locking means 44,  
20 whereby the connection or coupling between the collection receptacle 12<sub>1</sub> and the piston-filter arrangement 26 is created by means of a positive fit. In the actual case, the second coupling element 40 has a spherical section 46 that is surrounded, in the coupled state, by two locking arms 48<sub>1</sub> and 48<sub>2</sub> of the first coupling element 40 formed by the projection 38. The spherical section 46 forms back-cut sections 49, in which the  
25 locking arms 48<sub>1</sub> and 48<sub>2</sub> engage.

The collection receptacle shown in Figures 3a) and 3b) according to the second embodiment 12<sub>2</sub> differs only in the dimensions of the collection receptacle according to the first embodiment. As can be seen, in particular, from Figures 3a) and 3b), the  
30 central projection 38 has a coupling opening 52 that opens into the hollow space 39 and tapers conically viewed from the free end 41. Furthermore, the central projection 38 has two recesses 54 that pass through the wall 14 and separate the locking arms 48<sub>1</sub> and 48<sub>2</sub> from each other.

As can be further seen from Figure 2, the coupling elements 40, 42 are shaped so that the filter press 30 or the lower plate 34 of the filter press 30 has a distance X to the edge 18 of the collection receptacle 12<sub>1</sub> in the coupled state with respect to the longitudinal axis L. Consequently, in contrast to the infusion device shown 10 in Figures 1a) and 1a), it is not necessary to insert the filter press 30 for coupling in the collection receptacle 12<sub>1</sub>. The coupling elements 40, 42 define, in the coupled state, a unique position of the piston-filter arrangement 26 relative to the collection receptacle 12<sub>1</sub>, whereby the coupling is also enabled with a low expenditure of force, because the insoluble material 37 can be compressed only up to a certain degree of compression. The distance X is dimensioned so that a force that is not too high is applied to the water and the insoluble material 37 cannot be compressed so much that a portion of the water can flow suddenly from the area under the filter press 30 through the contact surface 36 into the area above the filter press 30.

The wall 14 of the collection receptacle 12<sub>1</sub> forms the base area 56 and a side area 58, wherein the wall 14 runs approximately perpendicular to the base area 56 in the side area 58. Furthermore, the collection receptacle 12<sub>1</sub> has a number of drainage openings 50 that are arranged in the base area 56 and in the transition area between the base area 56 and the side area 58 and pass through the wall 14 of the collection receptacle 12<sub>1</sub>, whereby water can be removed from the insoluble material 37 collected in the collection receptacle 12<sub>1</sub>. In addition, the passage openings 50 have the effect that an elevated pressure cannot build up in the collection receptacle 12<sub>1</sub>.

In particular, by means of the distance X between the edge 18 and the filter press 30 and with the use of the spherical section 46 of the second coupling element 42 and the locking arms 48 of the first coupling element 40 surrounding the spherical section 46, it is possible to rotate the collection receptacle 12<sub>1</sub> with respect to the piston-filter arrangement 26. In this way, the user can move the collection receptacle 12<sub>1</sub> into a position that is favorable for him or her relative to the piston-filter arrangement 26, which significantly simplifies the separation of the collection receptacle 12<sub>1</sub> from the piston-filter arrangement 26 after the infusion device 10 has been used.

As can be seen from Figure 3a), the collection receptacle 12<sub>2</sub> has the diameter DA and starting from the base area 56 at the edge 18 the height H2. The central projection 38 has, starting from the base area 56, the height H1. One can see that the projection 38 extends with a height difference  $\Delta H = H1 - H2$  past the edge 18.

5 In all of the embodiments of the collection receptacle 12 according to the proposal, the height difference is between 1 mm and 8 mm. Furthermore, the ratio of the height difference  $\Delta H$  to the diameter DA is between 0.01 and 0.07. The volume provided by the collection receptacle 12 is between 5 and 25 cm<sup>3</sup>.

10 In Table 1, three embodiments of collection receptacles 12 are listed with corresponding dimensions, dimensional ratios, and volumes. Also specified is the diameter DC of the container 10, with which the collection receptacle 12 can be used.

	Collection receptacle 1	Collection receptacle 2	Collection receptacle 3
DC (mm)	68	96	116.5
DA (mm)	61.2	88.5	107
H1 (mm)	39.9	53.6	43.6
H2 (mm)	36.3	50	40
$\Delta H$ (mm)	3.6	3.6	3.6
$\Delta H/DA$	0.058	0.041	0.034
V (cm <sup>3</sup> )	10.3	19.5	22.1

15

Table 1: Dimensions of various embodiments of the collection receptacle 12 according to the proposal.

20

## List of reference symbols

	10	Infusion device
	10P	Infusion device according to the prior art
5	12, 12 <sub>1</sub> , 12 <sub>2</sub>	Collection receptacle
	14	Wall
	16	Opening
	18	Edge
10	20	Container
	22	Open end
	24	Closed end
	26	Piston filter arrangement
	28	Piston rod
15		
	30	Press filter
	32	Upper plate
	34	Lower plate
	36	Contact surface
20	37	Insoluble material
	38	Projection
	39	Hollow space
	40	First coupling element
25	41	Free end
	42	Second coupling element
	44	Positive-locking means
	46	Spherical section
	48, 48 <sub>1</sub> , 48 <sub>2</sub>	Locking arm
30	49	Back-cut sections
	50	Drainage opening
	52	Coupling opening

	54	Recess
	56	Base area
	58	Side area
5	DA	Diameter of collection receptacle
	DC	Diameter of container
	H1	Height of projection
	H2	Height of collection receptacle at edge
	$\Delta H$	Height difference H1 – H2
10	L	Longitudinal axis
	V	Volume of collection receptacle
	X	Distance

## Patentkrav

- 5           1. Opsamlingsbeholder (12) til opsamling af uopløseligt materiale (37), som anvendes ved tilberedning af drikkevarer ved hjælp af en brygningsindretning (10), hvor brygningsindretningen (10) omfatter
- en beholder (20) med en åben ende (22) og en lukket ende (24) til optagelse af drikkevaren og det uopløselige materiale (37), og
  - en stempel-filterindretning (26), som kan indsættes i beholderen (20) hen over den åbne ende (22) og kan bevæges hen mod den lukkede ende (24),
- 10           hvor opsamlingsbeholderen (12)
- kan indsættes i beholderen (20),
  - en væg (14), som danner en åbning (16), som er omgivet af en kant (18), og
  - har i det mindste et første forbindelselement (40), som kan forbindes med i det mindst et andet forbindelselement (42) af stempel-filterindretningen (26) på en sådan måde, at der i den forbundne tilstand mellem kanten (18) af opsamlingsbeholderen (12) og stempel-filterindretningen (26) dannes en afstand (X), til hvilket formål det første forbindelselement (40) er anbragt på et centralt fremspring (38) af opsamlingsbeholderen (12), og det centrale fremspring (38) rager ud over kanten (18),
- 15           **kendetegnet ved, at**
- 20           - det centrale fremspring (38) omgiver et hulrum (39),
  - det første forbindelselement (40) omfatter en forbindelsesåbning (52), der udmunder i hulrummet (39), ved en fri ende (41) af det centrale fremspring (38), og
  - forbindelsesåbningen (52) set fra den frie ende (41) er konisk tilspidset.
- 25           2. Opsamlingsbeholder ifølge krav 1,
- kendetegnet ved, at** det centrale fremspring (38) har en første højde (H1), og opsamlingsbeholderen (12) i kanten (18) har en anden højde (H2), og det centrale fremspring (38) rager ud over kanten (18) med en højdeforskel ( $\Delta H$ ) på mellem 1 mm og 8 mm og især på mellem 2 mm og 6 mm.
- 30           3. Opsamlingsbeholder ifølge et af de foregående krav,
- kendetegnet ved, at** opsamlingsbeholderen (12) har en diameter (DA), og forholdet mellem højdeforskellen ( $\Delta H$ ) og diameteren (DA) udgør mellem 0,01 og 0,07.
- 35           4. Opsamlingsbeholder ifølge et af de foregående krav,
- kendetegnet ved, at** det centrale fremspring (38) har mindst en udsparring (54), der

udgår fra den frie ende (41) og går ind igennem væggen (14).

5. Opsamlingsbeholder ifølge et af de foregående krav,  
**kendetegnet ved, at** det centrale fremspring (38) dannes af væggen (14).

5

6. Opsamlingsbeholder ifølge et af de foregående krav,  
**kendetegnet ved, at** væggen (14) danner et bundområde (56) og et sideområde (58), hvor væggen (12) forløber i sideområdet (58) omtrent vinkelret på bundområdet (56).

10

7. Opsamlingsbeholder ifølge krav 6,  
**kendetegnet ved, at** opsamlingsbeholderen (12) har et antal af dræningsåbninger (50), der er anbragt i bundområdet (56).

15

8. Brygningsindretning til tilberedning af drikkevarer, omfattende  
- en beholder (20) med en åben ende (22) og en lukket ende (24) til optagelse af en drikkevare og af uopløseligt materiale (37),  
- en stempel-filterindretning (26), som kan indsættes i beholderen (20) hen over den åbne ende (22) og kan bevæges hen mod den lukkede ende (24), og  
- en opsamlingsbeholder (12), som kan indsættes i beholderen (20) ifølge et af de foregående krav, og som kan forbindes med stempel-filterindretningen (26), hvor der i den forbundne tilstand dannes en afstand (X) mellem kanten (18) af opsamlingsbeholderen (12) og stempel-filterindretningen (26).

20

25

9. Brygningsindretning ifølge krav 8,  
**kendetegnet ved, at** afstanden (X) mellem kanten (18) og stempel-filterindretningen (26) udgør mellem 3 og 10 mm, især mellem 3 og 6 mm.

30

10. Brygningsindretning ifølge et af kravene 8 eller 9,  
**kendetegnet ved, at** det første forbindelselement (40) og det andet forbindelselement (42) i den forbundne tilstand omfatter formlutningsmidler (44), der arbejder sammen med hinanden.

35

11. Brygningsindretning ifølge krav 10,  
**kendetegnet ved, at** det første forbindelselement (40) eller det andet forbindelselement (42) omfatter et i det væsentlige kugleformet eller cylinderformet afsnit

(46), som i den forbundne tilstand gribes om af låsearme (48) af det respektivt andet forbindelseselement (40, 42).

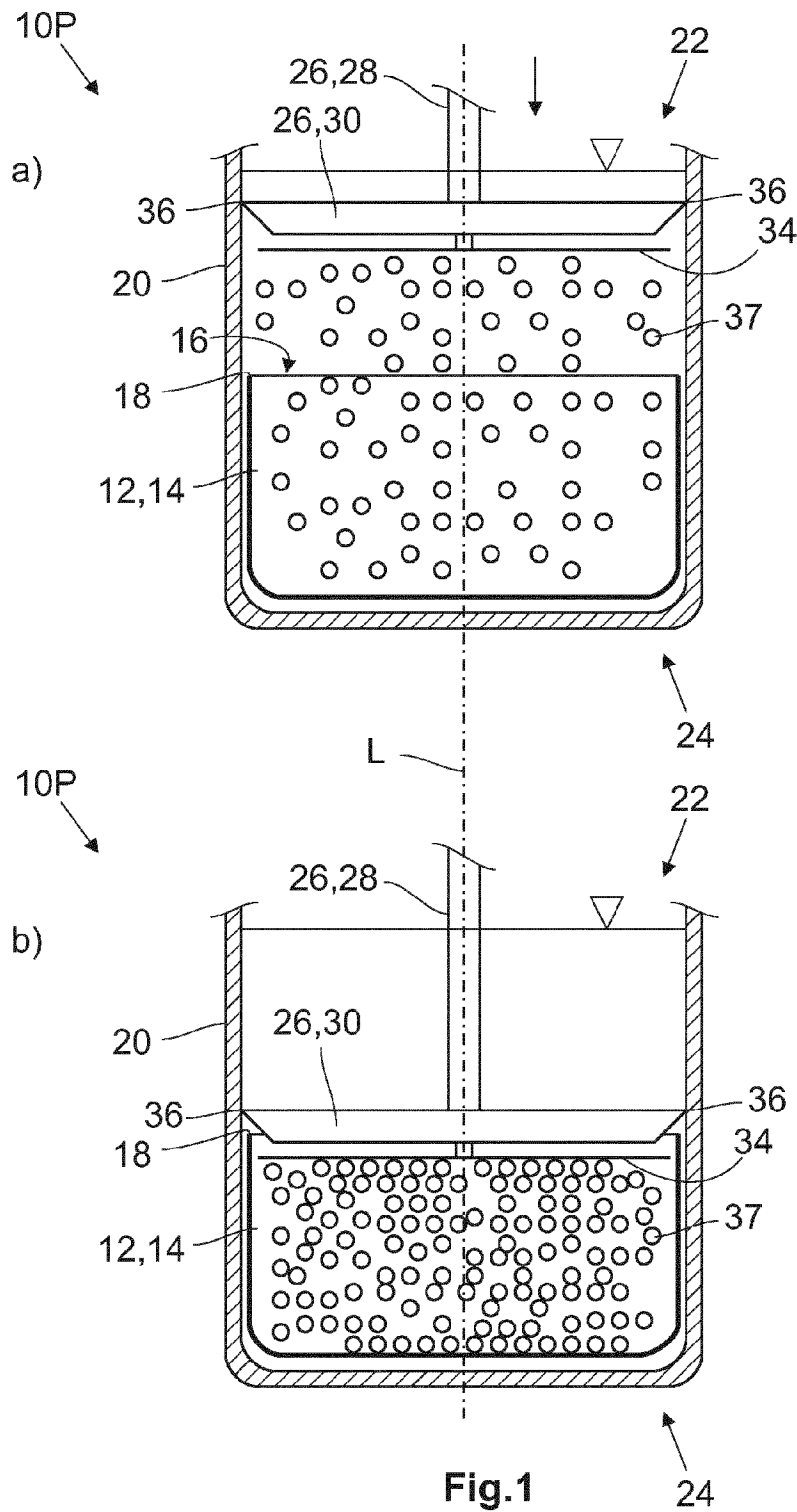

Fig.1

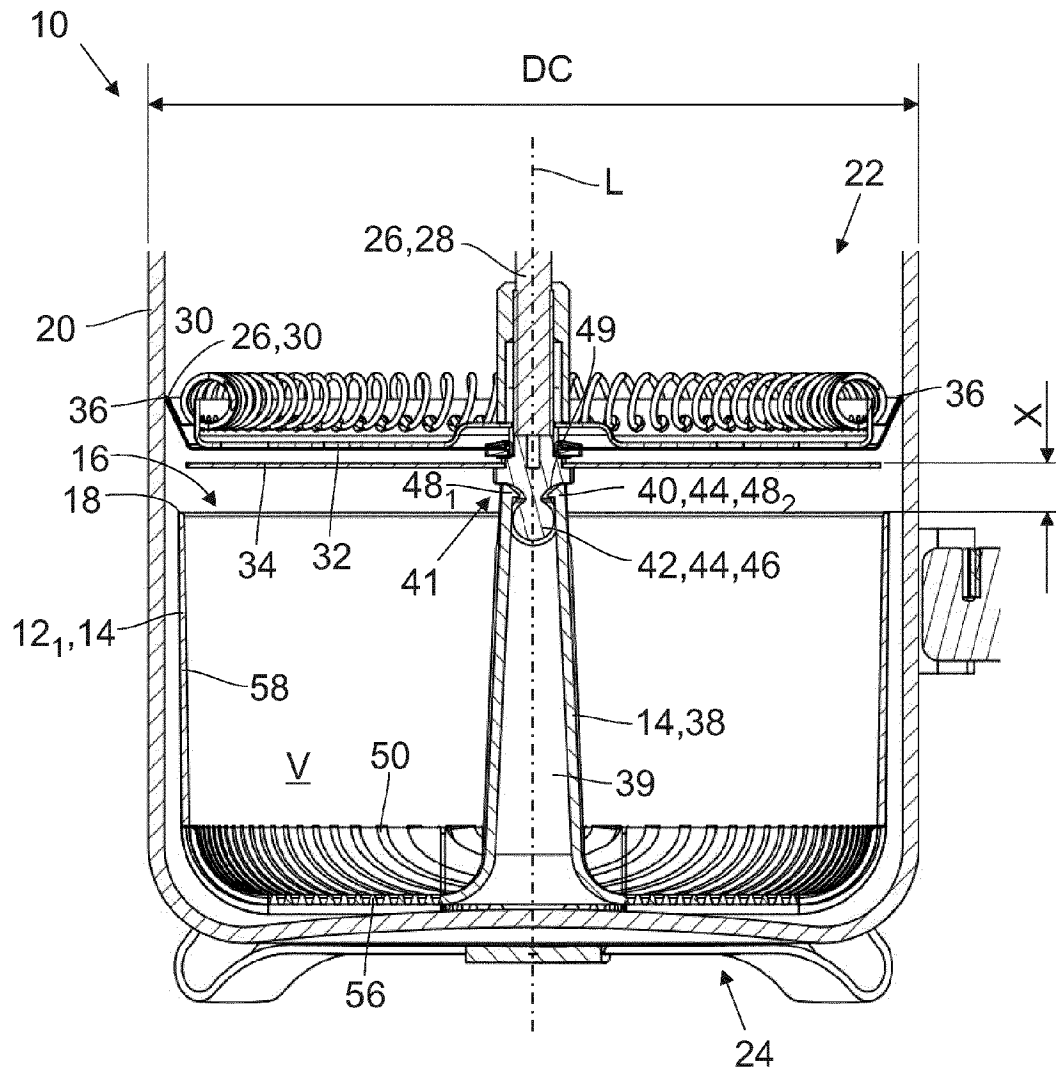

Fig.2

