



- (51) International Patent Classification:
E21B 19/02 (2006.01) E21B 19/15 (2006.01)
- (21) International Application Number:
PCT/US2017/030562
- (22) International Filing Date:
02 May 2017 (02.05.2017)
- (25) Filing Language: English
- (26) Publication Language: English
- (30) Priority Data:
62/330,721 02 May 2016 (02.05.2016) US
- (71) Applicant: CAMERON INTERNATIONAL CORPORATION [US/US]; 1333 West Loop South, Suite 1700, Houston, Texas 77027 (US).
- (72) Inventors: HOLLAND, Max; ANDOYFARET 3, 4623 KRISTIANSAND (NO). BERRY, Joe Rodney; 14034 CONWAY LANDING, CYPRESS, Texas 77429 (US). TINDVIK, Kristian; ANDOYFARET 3, 4623 KRISTIANSAND (NO).
- (74) Agent: RAYBAUD, Helene et al.; 4601 Westway Park Blvd, Houston, Texas 77041 (US).
- (81) Designated States (unless otherwise indicated, for every kind of national protection available): AE, AG, AL, AM, AO, AT, AU, AZ, BA, BB, BG, BH, BN, BR, BW, BY, BZ, CA, CH, CL, CN, CO, CR, CU, CZ, DE, DJ, DK, DM, DO, DZ, EC, EE, EG, ES, FI, GB, GD, GE, GH, GM, GT, HN, HR, HU, ID, IL, IN, IR, IS, JP, KE, KG, KH, KN, KP, KR, KW, KZ, LA, LC, LK, LR, LS, LU, LY, MA, MD, ME, MG, MK, MN, MW, MX, MY, MZ, NA, NG, NI, NO, NZ, OM, PA, PE, PG, PH, PL, PT, QA, RO, RS, RU, RW, SA, SC, SD, SE, SG, SK, SL, SM, ST, SV, SY, TH, TJ, TM, TN, TR, TT, TZ, UA, UG, US, UZ, VC, VN, ZA, ZM, ZW.
- (84) Designated States (unless otherwise indicated, for every kind of regional protection available): ARIPO (BW, GH, GM, KE, LR, LS, MW, MZ, NA, RW, SD, SL, ST, SZ, TZ, UG, ZM, ZW), Eurasian (AM, AZ, BY, KG, KZ, RU, TJ, TM), European (AL, AT, BE, BG, CH, CY, CZ, DE, DK, EE, ES, FI, FR, GB, GR, HR, HU, IE, IS, IT, LT, LU, LV, MC, MK, MT, NL, NO, PL, PT, RO, RS, SE, SI, SK, SM,

(54) Title: CATWALK AND CRANE SYSTEM

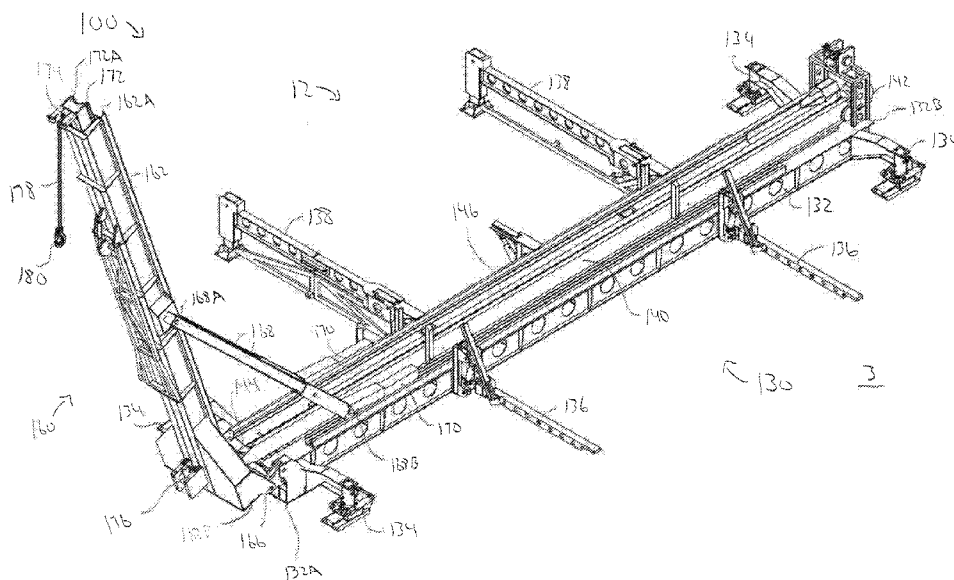

FIG 2

(57) Abstract: A catwalk and crane system for transporting equipment of a well system includes a substructure, a directing frame pivotally coupled to the substructure, a pipe transporter configured to transport a tubular along the directing frame, a first actuator coupled to the directing frame and configured to rotate the directing frame relative to the substructure, and a crane coupled to the directing frame, wherein the crane is extendable from a first end of the directing frame.



TR), OAPI (BF, BJ, CF, CG, CI, CM, GA, GN, GQ, GW,
KM, ML, MR, NE, SN, TD, TG).

Published:

— *with international search report (Art. 21(3))*

CATWALK AND CRANE SYSTEM

CROSS-REFERENCE TO RELATED APPLICATIONS

[0001] This application claims benefit of U.S. provisional patent application Serial No. 62/330,721 filed May 2, 2016, and entitled "Catwalk and Crane System," which is hereby incorporated herein by reference in its entirety.

STATEMENT REGARDING FEDERALLY SPONSORED RESEARCH OR DEVELOPMENT

[0002] Not applicable.

BACKGROUND

[0003] Well systems configured for the production of oil and gas include running tubular members or drill pipes into and out of a borehole of the well system that extends into a subterranean earthen formation. In some applications, the individual drill pipe joints are transported from a storage area distal a drilling platform of the well system to a rig floor of the drilling platform utilizing a catwalk machine or other system configured to transport the pipe joint. Once on the rig floor, the pipe joint may be threadably connected to another drill pipe joint to form part of a drill string extending through the rig floor and into the borehole via a wellhead disposed at the surface. In certain applications, equipment not easily transportable via the catwalk machine may need to be transported to and from the rig floor. This equipment can be located in various places around the drilling rig. In some applications, a crane, such as a mobile crane or a drill floor mounted crane, is used to lift and move the equipment to the drill floor and back again.

SUMMARY

[0004] An embodiment of a catwalk and crane system for transporting equipment of a well system comprises a substructure, a directing frame pivotally coupled to the substructure, a pipe transporter configured to transport a tubular along the directing frame, a first actuator coupled to the directing frame and configured to rotate the directing frame relative to the substructure, and a crane coupled to the directing frame, wherein the crane is extendable from a first end of the directing frame. In some embodiments, the directing frame is rotatable, the crane is extendable, and the pipe transporter is moveable up the directing frame to deliver a tubular to and from a rig floor of the well system. In some embodiments, the catwalk and crane system further comprises a winch coupled to a cable that is suspended from the crane, wherein the

winch is configured to extend and retract the cable, and the cable is configured to physically support a suspended load. In certain embodiments, when the load is coupled with the cable, the directing frame is configured to transport the load both vertically and horizontally in response to the extension of the crane from the first end of the directing frame. In certain embodiments, the catwalk and crane system further comprises a second actuator coupled to the directing frame and the crane, the second actuator configured to telescopically extend and retract the crane from the first end of the directing frame. In some embodiments, the load is coupled with the cable, the directing frame is configured to transport the load both vertically and horizontally in response to rotation of the directing frame relative to the substructure. In some embodiments, the pipe transporter comprises a catwalk skate configured to receive the tubular. In certain embodiments, the catwalk skate comprises rollers and is displaceable between the substructure and the directing frame to transport the tubular.

[0005] An embodiment of a catwalk and crane system for transporting equipment of a well system comprises a substructure, a directing frame pivotally coupled to the substructure, a pipe transporter configured to transport a tubular along the directing frame, a first actuator coupled to the directing frame and configured to rotate the directing frame relative to the substructure, a crane coupled to the directing frame, and a winch coupled to a cable that is suspended from the crane. In some embodiments, the winch is configured to extend and retract the cable, and the cable is configured to physically support a suspended load. In some embodiments, in response to actuation from the winch, the cable is configured to transport the load from a first position to a second position elevated from the first position. In certain embodiments, the catwalk and crane system further comprises a sheave coupled to a first end of the crane, wherein the sheave is configured to support the cable. In certain embodiments, the winch is coupled to the directing frame and rotatable with the directing frame relative to the substructure. In some embodiments, the first actuator is coupled between the directing frame and the substructure. In some embodiments, the catwalk and crane system further comprises a pipe support frame pivotally coupled to the substructure and to the directing frame, wherein the actuator is coupled between the pipe support frame and the directing frame.

[0006] An embodiment of a catwalk and crane system for transporting equipment of a well system comprises a substructure, a pipe support frame pivotally coupled to the substructure, a directing frame pivotally coupled to the pipe support frame, a pipe transporter configured to transport a tubular member along the directing frame, and a crane coupled to the directing frame, wherein the crane is extendable from a first end of the directing frame. In some embodiments, the catwalk and crane system further comprises a winch coupled to a cable that

is suspended from the crane, wherein the winch is configured to extend and retract the cable, and the cable is configured to physically support a suspended load. In some embodiments, the pipe support frame comprises a first support surface, the directing frame comprises a second support surface, the pipe transporter comprises a ram configured to push the tubular along the first support surface and the second support surface. In certain embodiments, the catwalk and crane system further comprises a strut coupled between the directing frame and the substructure, wherein the strut is pivotally coupled to the directing frame a pivot joint, and a first actuator coupled between the directing frame and the pipe support frame and configured to rotate the directing frame about the pivot joint relative to the strut. In some embodiments, the first actuator is configured to actuate the catwalk and crane system between a loading position configured to receive the tubular, and a transport position configured to transport the tubular between the first support surface and the second support surface.

BRIEF DESCRIPTION OF THE DRAWINGS

[0007] For a detailed description of exemplary embodiments, reference will now be made to the accompanying drawings in which:

[0008] Figure 1 is a schematic view of an embodiment of a well system in accordance with principles disclosed herein;

[0009] Figure 2 is a perspective view of an embodiment of a catwalk and crane system for drilling and/or production of hydrocarbons in accordance with principles disclosed herein;

[0010] Figure 3 is a side schematic view of the catwalk and crane system of Figure 2;

[0011] Figure 4 is a side view of the catwalk and crane system of Figure 2, with a crane unit in various retracted and extended positions;

[0012] Figure 5 is a side view of an extended operating position of the catwalk and crane system of Figures 2 and 4;

[0013] Figure 6 is a side view of an extended winch and cable operating position of the catwalk and crane system of Figures 2 and 4;

[0014] Figure 7 is a side view of an extended crane position of the catwalk and crane system of Figure 2 and 4;

[0015] Figure 8 is a side view of a directing frame and crane extended position of the catwalk and crane system of Figures 2 and 4;

[0016] Figure 9 is a perspective view of the catwalk and crane system of Figures 2-8 with pipe storage;

[0017] Figure 10 is a perspective view of another embodiment of a catwalk and crane system for drilling and/or production of hydrocarbons in accordance with principles disclosed herein;

[0018] Figure 11 is a side view of the catwalk and crane system of Figure 10;

[0019] Figure 12 is a side view of an operating position of the catwalk and crane system of Figure 10;

[0020] Figure 13 is a side view of an extended position of a crane of the catwalk and crane system of Figure 10; and

[0021] Figure 14 is a side view of a transport position of the catwalk and crane system of Figure 10.

DETAILED DESCRIPTION

[0022] In the drawings and description that follow, like parts are typically marked throughout the specification and drawings with the same reference numerals. The drawing figures are not necessarily to scale. Certain features of the disclosed embodiments may be shown exaggerated in scale or in somewhat schematic form and some details of conventional elements may not be shown in the interest of clarity and conciseness. The present disclosure is susceptible to embodiments of different forms. Specific embodiments are described in detail and are shown in the drawings, with the understanding that the present disclosure is to be considered an exemplification of the principles of the disclosure, and is not intended to limit the disclosure to that illustrated and described herein. It is to be fully recognized that the different teachings of the embodiments discussed below may be employed separately or in any suitable combination to produce desired results.

[0023] Unless otherwise specified, in the following discussion and in the claims, the terms “including” and “comprising” are used in an open-ended fashion, and thus should be interpreted to mean “including, but not limited to ...”. Any use of any form of the terms “connect”, “engage”, “couple”, “attach”, or any other term describing an interaction between elements is not meant to limit the interaction to direct interaction between the elements and may also include indirect interaction between the elements described. The various characteristics mentioned above, as well as other features and characteristics described in more detail below, will be readily apparent to those skilled in the art upon reading the following detailed description of the embodiments, and by referring to the accompanying drawings.

[0024] Figure 1 is a schematic diagram showing an embodiment of a well system 10 having a central or longitudinal axis 15. Well system 10 may be configured to extract various minerals and natural resources, including hydrocarbons (e.g., oil and/or natural gas), or to inject

substances into an earthen formation 5 extending beneath the surface or ground 3 via a well or wellbore 8. In this arrangement, central axis 15 of system 10 extends substantially vertically (e.g., extending substantially parallel to the Y-axis shown in Figure 1) relative to the substantially horizontally or laterally extending (e.g., extending substantially parallel to the X-axis shown in Figure 1) surface 3. In the embodiment shown in Figure 1, well system 10 generally includes a drilling rig or platform 20, a wellhead 28, and a catwalk machine or transportation assembly 100. Rig 20 includes a rig floor 22 extending between a pair of lateral sides or ends 24, where rig floor 22 is elevated or vertically spaced from the surface 3. Additionally, in the embodiment shown in Figure 1, rig 20 also includes a derrick or mast 26 extending vertically along central axis 15 from rig floor 22, where mast 26 is configured to assist in the insertion and removal of tubular members, such as drill pipes, from wellbore 8.

[0025] Wellhead 28 of well system 10 extends vertically from surface 3 and is disposed coaxial with central axis 15 of well system 10. Wellhead 28 is generally configured to control fluid communication between wellhead 8 and the surrounding environment and to allow for the insertion and removal of a drill string 30 of well system 10 from wellbore 8, where drill string 30 comprises a series of tubular members or drill pipes threadably connected end-to-end. For example, when running drill string 30 into wellbore 8, an individual drill pipe joint may be transported to rig floor 22 and coupled with an upper end of drill string 30 extending vertically through a hole in the rig floor 22 that is aligned with central axis 15. In the embodiment shown in Figure 1, tubular members, such as drill pipe joints of drill string 30, or other equipment may be located in a storage area 12 that is both vertically and horizontally spaced from the rig floor 22 of rig 20. In the embodiment shown in Figure 1, transport assembly 100 of well system 10 is configured to transport tubular members, including drill pipe joints of drill string 30, between storage area 12 and rig floor 22. Additionally, as will be described further herein, transport assembly 100 is also configured to transport equipment other than tubular members between rig floor 22 and locations vertically and horizontally spaced from rig floor 22.

[0026] Referring to Figures 2 and 3, a tubular handling and transport system 100 (also referred to as a catwalk and crane system, or catwalk machine with crane) includes a catwalk unit 130 and crane unit 160. The catwalk unit 130 includes a substructure or support frame 132 with hydraulic moving feet 134, a first pair of moveable or retractable tubular support arms 136 extending from a first lateral side of support frame 132, and a second pair of moveable or retractable tubular support arms 138 extending from a second, opposing lateral side of support frame 132. Support frame 132 of catwalk unit 130 includes a first end 132A and a second end 132B longitudinally spaced from first end 132A. Feet 134 engage surface 3 to support catwalk

unit 130 from each end 132A and 132B of support frame 132. Second support arms 138 of catwalk unit 130 may be positioned proximal the storage area 12 of well system 10. Referring briefly to Figure 9, in some embodiments, catwalk unit 130 of crane system 100 may include a storage platform 139 supported by second side support arms 138, where storage platform 139 stores a plurality of tubular members or drill pipe joints 32 of well system 10. Referring again to Figures 2 and 3, the embodiment of catwalk unit 130 shown in Figures 2 and 3 also includes a pipe transporter or catwalk skate 140 having rollers 142 and 144 disposed at opposing longitudinal ends thereof and a tubular support surface 146 extending between the longitudinal ends of skate 140.

[0027] In the embodiment shown in Figures 2 and 3, crane unit 160 of crane system 100 includes a ramp or directing frame 162 and a telescopic member or crane 172 moveably or telescopically mounted within the directing frame 162. A pivotal coupling 166 connects the directing frame 162 to the catwalk unit 130. Particularly, directing frame 162 has a first longitudinal end 162A and a second longitudinal end 162B. The second end 162B of ramp 160 is pivotally coupled to the first end 132A of support frame 132 at a pivotal coupling or joint 166. Additionally, crane unit 160 includes a pair of adjustable struts 168, where a first longitudinal end of each strut 168 pivotally couples to a lateral side of directing frame 162 at a first pivotal coupling or joint 168A while a second longitudinal end of each strut 168 pivotally couples to an actuator or extension cylinder 170 at a second pivotal coupling or joint 168B.

[0028] First pivot joints 168A of struts 168 are longitudinally spaced from the ends 162A and 162B of directing frame 162 while extension cylinders 170 are coupled to support frame 132 of catwalk unit 130 proximal to, but longitudinally spaced from first end 132A of support frame 132. Each extension cylinder 170 is configured to extend and retract in a substantially horizontal direction (e.g., in a direction substantially parallel with the X-axis shown in Figure 1) such that extension/retraction of extension cylinders 170 induces rotation of directing frame 162 about pivot joint 166 via the connection provided between extension cylinders 170 and directing frame 162 by struts 168. Additionally, an actuatable hydraulic cylinder or actuator 169 is mounted within each of the struts 168 to adjust the struts 168 and cause luffing of the directing frame 162. Particularly, each cylinder 169 is configured to extend or retract a corresponding strut 168, thereby rotating directing frame 162 about pivot joint 166.

[0029] During operation, skate 140 is configured to transport a tubular member, such as drill pipe joints 32, relative to support frame 132 of catwalk unit 130 and crane unit 160 when the tubular member is transported between storage area 12 and rig floor 22. In the embodiment shown in Figures 2 and 3, skate 140 is configured to receive or physically support a tubular

member and may be moved or transported between support frame 132 and frame 162 via rollers 142 and 144, and a drive mechanism or actuator (not shown). In some embodiments, the drive mechanism comprises a chain or cable drive. In other embodiments, the drive mechanism may comprise various other drives known to be used for catwalk skates.

[0030] In the embodiment shown in Figures 2 and 3, crane 172 is received at least partially within directing frame 162 and configured to telescopically extend and retract from the first end 162A of directing frame 162. In this arrangement, crane unit 160 has a longitudinal distance or length extending between a first or outer end 172A of crane 172 and the second end 162B of directing frame 162, where the longitudinal distance between outer end 172A of crane 172 and the second end 162B of directing frame 162 may be adjusted or altered by extending or retracting crane 172. As shown particularly in Figure 3, a hydraulic cylinder or actuator 173 is received in and coupled with directing frame 162. Hydraulic cylinder 173 is also coupled to a second or inner end 172B of crane 172 and is configured to displace crane 172 telescopically (indicated by arrow 177 in Figure 3) along a central or longitudinal axis 165 of crane unit 160 relative to directing frame 162. In this arrangement, hydraulic cylinder 173 is configured to extend and retract crane 172 from first end 162A of directing frame 162.

[0031] In the embodiment shown in Figures 2 and 3, crane unit 160 also includes a winch 176 mounted proximal the second end 162B of directing frame 162 that controls a cable or line 178 extending from winch 176, through or around a sheave 174 mounted to the first end 162A of directing frame 162, and to a releasable connector or hook 180. In this arrangement, sheave 174 is configured to support cable 178 and facilitate the retraction and extension of cable 178 from winch 176. Cable 178 is configured to support the weight of equipment 182 suspended from hook 180 while winch 176 is configured to extend and retract cable 178, which thereby vertically lowers and raises hook 180 relative to the surface 3. In this manner, the vertical position of equipment 182 (e.g., position of equipment 182 along a vertical axis parallel to the Y-axis shown in Figure 1) suspended from hook 180 may be adjusted in isolation. In other words, actuating winch 176 allows an operator of crane system 100 to adjust only the vertical position of equipment 182. In some applications, the ability to independently adjust the position of equipment 182 suspended from transport assembly 100 along only a single axis (e.g., a vertical axis relative surface 3) may simplify and/or provide greater flexibility in the operation of transporting equipment 182 via crane system 100.

[0032] Referring to Figures 4-8, the operation of crane system 100 will now be described in view of the embodiment of crane system 100 shown in Figures 4-8. Particularly, in operation, crane unit 160 of crane system 100 includes an initial or retracted position 190 shown in Figure

4 where frame 162 is disposed substantially horizontally adjacent support frame 132. In the retracted position 190, extension cylinders 170 may be actuated to react against struts 168 and thereby rotate struts 168 about pivot joints 168B and in-turn rotate directing frame 162 about pivot joint 166 (via the connection formed between struts 168 and directing frame 162 at pivot joints 168A) until crane unit 160 is disposed in a second or intermediate position 192 (shown in dashed lines in Figure 4). In the intermediate position 192, extension cylinders 170 may continue to actuate and thereby rotate struts 168 about pivot joints 168B and frame 162 about pivot joint 166 until crane unit 160 is disposed in an extended or operating position 194 (shown also in dashed lines in Figure 4). In the operating position 194, as will be detailed more fully below, the cylinders 169 disposed in struts 168 may be actuated to luff, or lift and lower by rotation, the directing frame 162.

[0033] Figure 5 illustrates crane system 100 with crane unit 160 in the operating position 194. As shown in Figure 5, prior to coupling hook 180 with equipment 182, crane unit 160 is disposed in the operating position 194 and cable 178 is retracted until hook 180 is disposed in a first or retracted position proximal sheave 174 and distal the surface 3. With hook 180 disposed in the retracted position shown in Figure 5, equipment 182 to be transported from a position at or proximal surface 3 to the rig floor 22 of drilling rig 20 may be positioned proximal crane system 100, as shown in Figure 6. Following the positioning of equipment 182 proximal to crane system 100, winch 176 may be actuated to lower the cable 178 and hook 180 to a second or extended position where hook 180 is disposed proximal the surface 3. In the position shown in Figure 6, hook 180 may be releasably coupled with equipment 182 disposed at the surface 3.

[0034] Following the coupling of equipment 182 with hook 180, equipment 182 may be lifted from the surface 3 via cable 178, as shown in Figure 7. Particularly, in the embodiment shown in Figures 4-8, cylinder 173 is actuated to telescopically extend crane 172 along central axis 165 from the first end 162A of directing frame 162. Given that central axis 165 of crane unit 160 is disposed at an angle relative the vertical and horizontal axes (the Y-axis and X-axis shown in Figure 1, respectively), extension of crane 172 along central axis 165 transports equipment 182 both vertically from surface 3 and horizontally towards rig floor 22.

[0035] In some embodiments, either prior to, during, or following the actuation of cylinder 173, winch 176 may be actuated to retract cable 178 and hook 180 to thereby vertically lift equipment 182. In embodiments where winch 176 and cylinder 173 are not operated simultaneously, winch 176 allows crane system 100 to transport equipment 182 in a single axial direction. Particularly, actuation of winch 176 is configured to transport equipment 182

in only a vertical direction (e.g., along an axis parallel with the Y-axis shown in Figure 1). In some embodiments, winch 176 may be used to lift equipment 182 to a position above rig floor 22 prior to equipment 182 being transported horizontally (e.g., in a direction parallel with the X-axis shown in Figure 1) towards rig floor 22 of drilling rig 20. In some applications, vertically lifting equipment 182 to a position vertically above rig floor 22 prior to transporting lifting equipment 182 in a horizontal direction may reduce the possibility of colliding equipment 182 with a lateral side 24 of rig 20 during a transport operation.

[0036] In the embodiment shown in Figures 4-8, equipment 182 is lifted via winch 176 and/or cylinder 173 until it occupies an upper or elevated position vertically elevated from (but horizontally spaced from) rig floor 22. Once equipment 182 is disposed in the elevated position, equipment 182 may be transported in a horizontal direction towards rig floor 22, as shown in Figures 7 and 8. Particularly, in the embodiment shown in Figures 4-8, cylinders 169 of struts 168 may be actuated to rotate the directing frame 162 about pivot joint 166 to thereby transport equipment 182 until it is disposed over rig floor 22 (e.g., until equipment 182 is no longer horizontally spaced from rig floor 22) and lower equipment 184 onto rig floor 22, as shown in Figure 8. In other embodiments, rotation of directing frame 162 via the actuation of cylinders 169 may place equipment 182 vertically over rig floor 22, and actuation of winch 176 may be used to vertically lower cable 178 until equipment 182 is placed or landed against rig floor 22. Furthermore, in the operating position 194 of crane unit 160 shown in Figure 8, skate 140 of crane system 100 may be actuated to transport a tubular member (e.g., a pipe joint 32, etc.) from storage area 12 to the rig floor 22 with the first end 172A of crane 172 disposed vertically over rig floor 22.

[0037] The embodiment of crane system 100 shown in Figures 2-8 may be retracted to the various positions described above by reversing the actuation and order of the components and steps previously described. Thus, in some embodiments, crane system 100 provides a catwalk machine with an integrated or combined crane that extends from the adjustable directing frame to transport loads to and from the drill floor and to provide support to the catwalk skate for delivering drill pipe from a pipe storage area to a rig floor and back again.

[0038] Referring to Figures 10 and 11, another embodiment of a tubular handling and transport system 200 (also referred to as a catwalk and crane system, or catwalk machine with crane) for use with the well system 10 of Figure 1 is shown. Crane system 200 includes features in common with the crane system 100 shown in Figures 2-8 and shared features are labeled similarly. As with crane system 100 described above, crane system 200 is configured to provide the functionality of a catwalk machine and a lifting crane in a single transport system,

thereby allowing for the transport of tubular members between a storage area and rig floor of a drilling rig and the lifting of equipment disposed at or near the surface to the rig floor.

[0039] In the embodiment shown in Figures 10 and 11, crane system 200 a catwalk unit 210 and crane unit 230. The catwalk unit 210 includes a substructure or support frame 212 with hydraulic moving feet 134 and support arms 136 and 138. Substructure 212 of catwalk unit 210 includes a first end 212A, a second end 212B longitudinally spaced from first end 212A. Additionally, catwalk unit 210 includes a pivotable tubular member or pipe support frame 214 having an upper or pipe support surface 215. Pipe support frame 214 has a first end 214A, a second end 214B longitudinally spaced from first end 214A, and an upper or pipe support surface 215 extending therebetween. Pipe support frame 214 is pivotally coupled with substructure 212 at a pivot joint 216 positioned at the second ends 212B and 214B of substructure 212 and pipe support frame 214, respectively. Additionally, a pipe transporter or catwalk ram or pusher 217 extends from support surface 215 and is configured to move longitudinally along support surface 215 when actuated via an actuator (not shown) to thereby transport a pipe or tubular member along support surface 215.

[0040] In the embodiment shown in Figures 10 and 11, crane unit 230 of crane system 200 includes a directing frame 232 having a first end 232A, a second end 232B longitudinally spaced from first end 232A, and an upper or pipe support surface 234 extending therebetween. Similar to the configuration of the crane unit 160 of crane system 100 described above, crane unit 230 also includes a telescopic member or crane 236 telescopically received in directing frame 232, where crane 236 is configured to telescopically extend and retract from the first end 232A of directing frame 232 in response to the actuation of a hydraulic cylinder or actuator (not shown) coupled to directing frame 232. Crane 236 has a first or outer end 236A that includes sheave 174 and a roller 238 for facilitating the transport of a tubular member along support surface 234 of directing frame 232. Similar to crane system 100, winch 176 is coupled to directing frame 232 proximal second end 232B. In some embodiments, support surface 215 comprises a first support surface 215 while support surface 234 comprises a second support surface 234.

[0041] The second end 232B of directing frame 232 is pivotally coupled to the first end 214A of pipe support frame 214 via a first or upper pivot joint 240. Additionally, in the embodiment shown in Figures 10 and 11, crane system 100 includes a pair of erecting cylinders or actuators 218 coupled to substructure 212 of crane unit 210. The second end 232B of directing frame 232 is pivotally coupled to each erecting cylinder 218 via a pair of second or lower pivot joints 242. Additionally, erecting cylinders 218 are coupled with pipe support frame 214 at a pair of third pivot joints 244 (shown in Figure 14), where third pivot joints 244 are positioned proximal the

first end 214A of pipe support frame 214. Thus, erecting cylinders 218 are coupled between the pipe support frame 214 and the directing frame 232. In this arrangement, extension of erecting cylinders 218 is configured to rotate directing frame 232 in a first rotational direction (indicated by arrow 219 in Figure 11) about upper pivot joint 240 while retraction of erecting cylinders 218 is configured to rotate directing frame 232 in a second rotational direction (indicated by arrow 221 in Figure 11) about upper pivot joint 240 opposite the first rotational direction 219. Particularly, extension of erecting cylinders 218 is configured to rotate directing frame 232 such that an angle formed between longitudinal axes of frames 232 and 214 is increased (e.g., the axes are closer to being orthogonal), while retraction of erecting cylinders 218 is configured to rotate directing frame 232 such that the angle formed between longitudinal axes of frames 232 and 214 is decreased (e.g., the axes are closer to being parallel).

[0042] In the embodiment shown in Figures 10 and 11, crane system 200 also includes a pivotable frame 250 having a first end 250A and a second end 250B longitudinally spaced from first end 250A. The first end 250A of pivotable frame 250 is pivotally coupled to directing frame 232 via a first pivot joint 252 located between or spaced from ends 232A and 232B of directing frame 232. The second end 250B of pivotable frame 250 is also pivotally coupled to substructure 212 via a second pivot joint 254 located at the first end 212A of substructure 212. In this arrangement, pivotable frame 250 is configured to restrict the movement of directing frame 232 such that retraction of erecting cylinders 218 results in rotation of pipe support frame 214 about pivot joint 216 in the first rotational direction 219, as will be discussed further herein.

[0043] Referring to Figures 12-14, crane system 200 is illustrated in Figures 12-14 transporting equipment 182 from a position at or near the surface 3 to the rig floor 22. Particularly, Figure 12 illustrates crane unit 230 of crane system 200 in an operating position 250 with equipment 182 suspended from cable 178 and crane 236 in a retracted position within directing frame 232. As shown in Figure 13, the first end 236A of crane 236 may be telescopically extended from directing frame 232 to transport equipment 182 both vertically and horizontally relative the surface 3 via a hydraulic cylinder similar to cylinder 173 of crane system 100.

[0044] As shown in Figure 14, with crane 236 extended from directing frame 232 and equipment 182 suspended from cable 178, erecting cylinders 218 may be extended to pivot directing frame 232 and crane 236 in the second rotational direction 221 about first pivot joint 252, thereby reducing an angle formed between support surface 215 and support surface 234. In some embodiments, with crane system 200 in the position shown in Figure 14, a tubular member driven or pushed by pusher 217 may be transported between support surface 215 and support surface 234 to transport the tubular member to the rig floor 22. Thus, the position of crane

system 200 shown in Figure 14 comprises a pipe transport position 252 configured to transport pipes or other tubular members between storage area 12 and the rig floor 22, whereas the position of crane system 200 shown in Figures 12 and 13 comprises a pipe loading position where pipe support frame 214 is configured to receive a pipe or other tubular member from the storage area 12. Additionally, the extension of erecting cylinders 218 transports equipment 182 horizontally relative surface 3 to dispose equipment 182 above rig floor 22 such that equipment 182 overhangs the side 24 of rig floor 22. Thus, by actuating crane system 200 into the transport position 252 from the loading position shown in Figures 12 and 13, equipment 182 is transported horizontally towards rig floor 22.

[0045] The embodiment of crane system 200 shown in Figures 10-14 may be retracted to the various positions described above by reversing the actuation and order of the components and steps previously described. Thus, in some embodiments, crane system 200 provides a catwalk machine with an integrated or combined crane that extends from the adjustable directing frame to transport loads to and from the drill floor and to provide support to the catwalk ram for delivering drill pipe from a pipe storage area to a rig floor and back again.

[0046] The above discussion is meant to be illustrative of the principles and various embodiments of the present disclosure. While certain embodiments have been shown and described, modifications thereof can be made by one skilled in the art without departing from the spirit and teachings of the disclosure. The embodiments described herein are exemplary only, and are not limiting. Accordingly, the scope of protection is not limited by the description set out above, but is only limited by the claims which follow, that scope including all equivalents of the subject matter of the claims.

CLAIMS

What is claimed is:

1. A catwalk and crane system for transporting equipment of a well system, comprising:
a substructure;
a directing frame pivotally coupled to the substructure;
a pipe transporter configured to transport a tubular along the directing frame;
a first actuator coupled to the directing frame and configured to rotate the directing frame relative to the substructure; and
a crane coupled to the directing frame, wherein the crane is extendable from a first end of the directing frame.
2. The catwalk and crane system of claim 1, wherein the directing frame is rotatable, the crane is extendable, and the pipe transporter is moveable up the directing frame to deliver a tubular to and from a rig floor of the well system.
3. The catwalk and crane system of claim 1, further comprising:
a winch coupled to a cable that is suspended from the crane;
wherein the winch is configured to extend and retract the cable, and the cable is configured to physically support a suspended load.
4. The catwalk and crane system of claim 3, wherein, when the load is coupled with the cable, the directing frame is configured to transport the load both vertically and horizontally in response to the extension of the crane from the first end of the directing frame.
5. The catwalk and crane system of claim 4, further comprising a second actuator coupled to the directing frame and the crane, the second actuator configured to telescopically extend and retract the crane from the first end of the directing frame.
6. The catwalk and crane system of claim 3, wherein, when the load is coupled with the cable, the directing frame is configured to transport the load both vertically and horizontally in response to rotation of the directing frame relative to the substructure.

7. The catwalk and crane system of claim 1, wherein the pipe transporter comprises a catwalk skate configured to receive the tubular.
8. The catwalk and crane system of claim 1, wherein the catwalk skate comprises rollers and is displaceable between the substructure and the directing frame to transport the tubular.
9. A catwalk and crane system for transporting equipment of a well system, comprising:
 - a substructure;
 - a directing frame pivotally coupled to the substructure;
 - a pipe transporter configured to transport a tubular along the directing frame;
 - a first actuator coupled to the directing frame and configured to rotate the directing frame relative to the substructure;
 - a crane coupled to the directing frame; and
 - a winch coupled to a cable that is suspended from the crane.
10. The catwalk and crane system of claim 9, wherein the winch is configured to extend and retract the cable, and the cable is configured to physically support a suspended load.
11. The catwalk and crane system of claim 10, wherein, in response to actuation from the winch, the cable is configured to transport the load from a first position to a second position elevated from the first position.
12. The catwalk and crane system of claim 9, further comprising a sheave coupled to a first end of the crane, wherein the sheave is configured to support the cable.
13. The catwalk and crane system of claim 9, wherein the winch is coupled to the directing frame and rotatable with the directing frame relative to the substructure.
14. The catwalk and crane system of claim 9, wherein the first actuator is coupled between the directing frame and the substructure.
15. The catwalk and crane system of claim 9, further comprising:
 - a pipe support frame pivotally coupled to the substructure and to the directing frame;
 - wherein the actuator is coupled between the pipe support frame and the directing frame.

16. A catwalk and crane system for transporting equipment of a well system, comprising:
a substructure;
a pipe support frame pivotally coupled to the substructure;
a directing frame pivotally coupled to the pipe support frame;
a pipe transporter configured to transport a tubular member along the directing frame;
and
a crane coupled to the directing frame, wherein the crane is extendable from a first end of the directing frame.
17. The catwalk and crane system of claim 16, further comprising:
a winch coupled to a cable that is suspended from the crane;
wherein the winch is configured to extend and retract the cable, and the cable is configured to physically support a suspended load.
18. The catwalk and crane system of claim 16, wherein:
the pipe support frame comprises a first support surface;
the directing frame comprises a second support surface; and
the pipe transporter comprises a ram configured to push the tubular along the first support surface and the second support surface.
19. The catwalk and crane system of claim 18, further comprising:
a strut coupled between the directing frame and the substructure, wherein the strut is pivotally coupled to the directing frame a pivot joint; and
a first actuator coupled between the directing frame and the pipe support frame and configured to rotate the directing frame about the pivot joint relative to the strut.
20. The catwalk and crane system of claim 19, wherein the first actuator is configured to actuate the catwalk and crane system between a loading position configured to receive the tubular, and a transport position configured to transport the tubular between the first support surface and the second support surface.

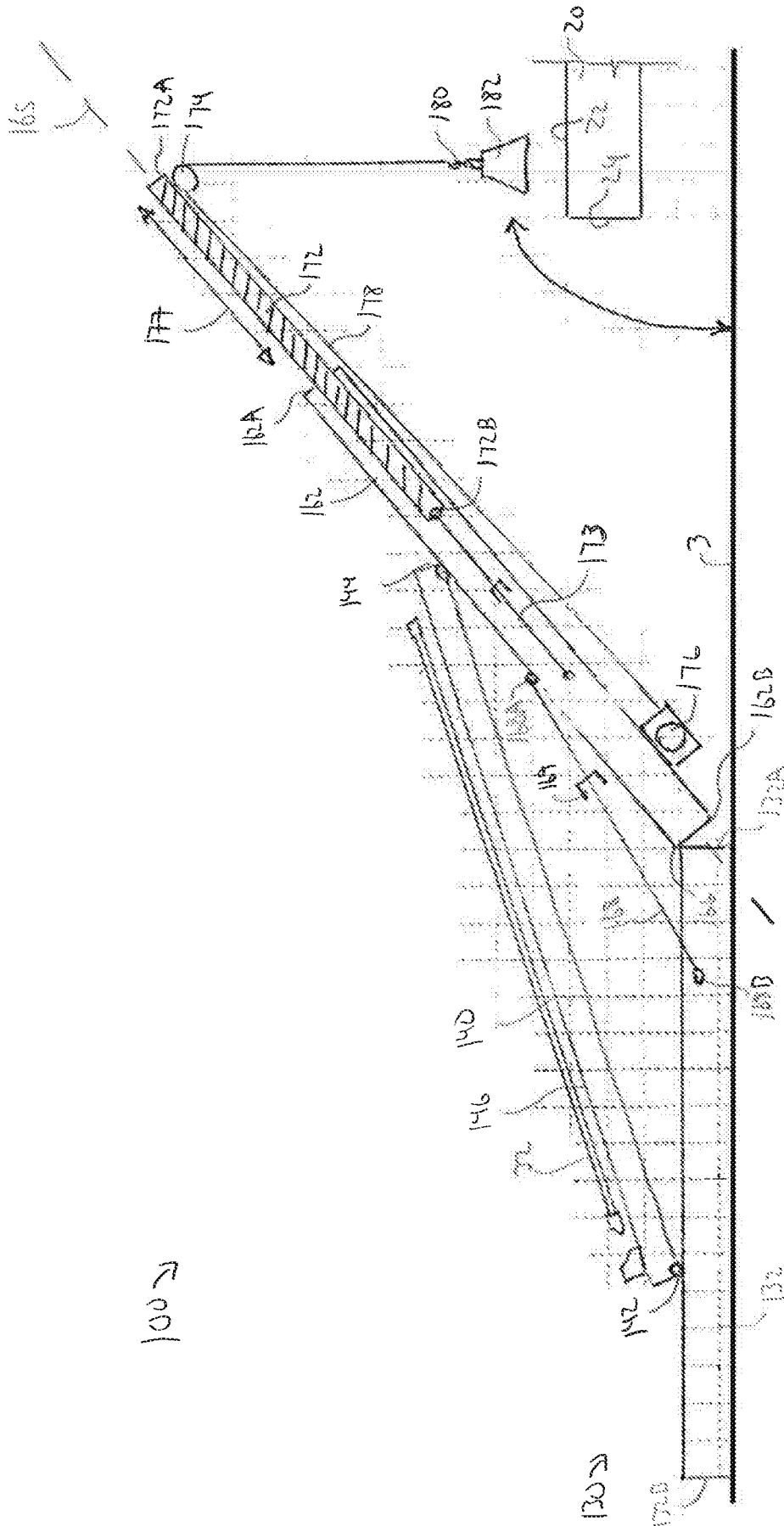

FIG 3

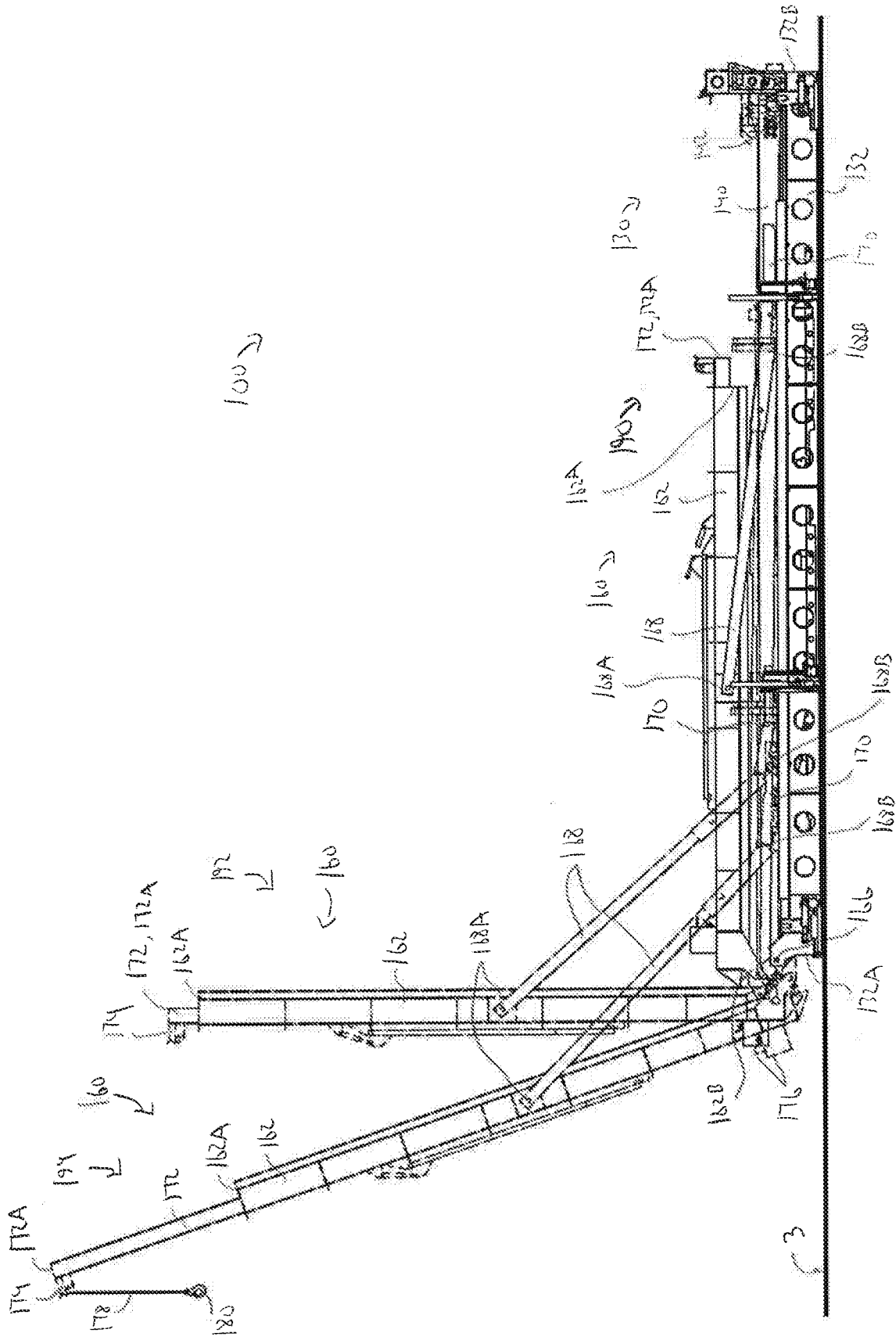
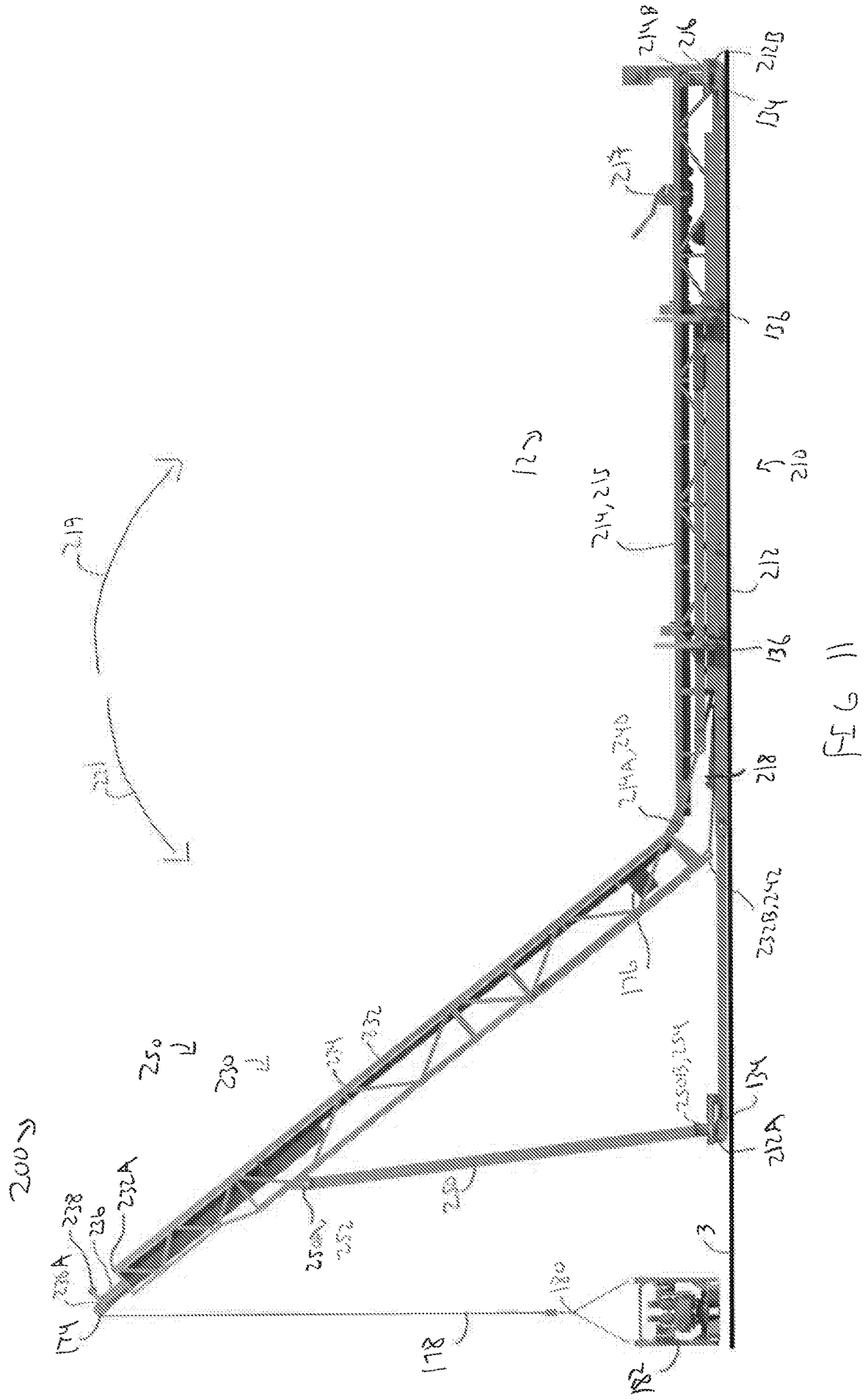

FIG 4



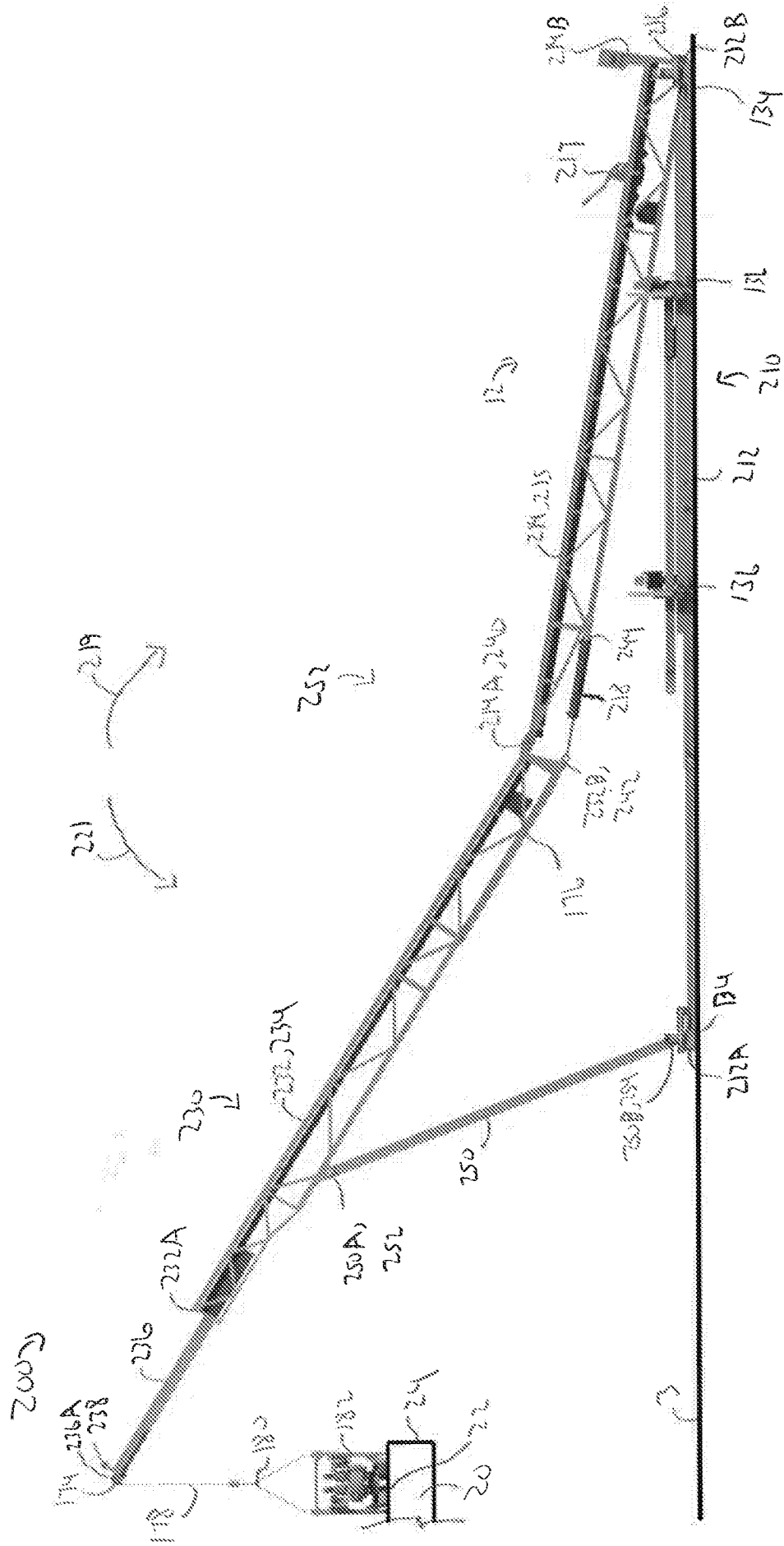

FIG 14

A. CLASSIFICATION OF SUBJECT MATTER**E21B 19/02(2006.01)i, E21B 19/15(2006.01)i**

According to International Patent Classification (IPC) or to both national classification and IPC

B. FIELDS SEARCHEDMinimum documentation searched (classification system followed by classification symbols)
E21B 19/02; B63B 39/02; E21B 7/12; E21B 19/15; E21B 19/14Documentation searched other than minimum documentation to the extent that such documents are included in the fields searched
Korean utility models and applications for utility models
Japanese utility models and applications for utility modelsElectronic data base consulted during the international search (name of data base and, where practicable, search terms used)
eKOMPASS(KIPO internal) & Keywords: catwalk, transport, tubular, actuator, crane, extend, winch and cable**C. DOCUMENTS CONSIDERED TO BE RELEVANT**

Category*	Citation of document, with indication, where appropriate, of the relevant passages	Relevant to claim No.
Y	US 2011-0070054 A1 (CROSSLEY, NATHAN et al.) 24 March 2011 See paragraphs [0046]-[0072]; claim 1; and figures 1-6.	1-20
Y	US 3534867 A (JOHNSTON, ROGER L. et al.) 20 October 1970 See column 2, line 30 - column 4, line 49 and figures 1-6.	1-20
A	US 2010-0307401 A1 (BEREZNITSKI, ALEXEI et al.) 09 December 2010 See paragraphs [0051]-[0058] and figures 1-4.	1-20
A	US 2011-0044787 A1 (FIKOWSKI, LARRY M. et al.) 24 February 2011 See paragraphs [0022]-[0052] and figures 1-12.	1-20
A	US 2012-0027541 A1 (GERBER, ANDREW et al.) 02 February 2012 See paragraphs [0026]-[0045] and figures 1-10.	1-20

 Further documents are listed in the continuation of Box C. See patent family annex.

* Special categories of cited documents:

"A" document defining the general state of the art which is not considered to be of particular relevance

"E" earlier application or patent but published on or after the international filing date

"L" document which may throw doubts on priority claim(s) or which is cited to establish the publication date of another citation or other special reason (as specified)

"O" document referring to an oral disclosure, use, exhibition or other means

"P" document published prior to the international filing date but later than the priority date claimed

"T" later document published after the international filing date or priority date and not in conflict with the application but cited to understand the principle or theory underlying the invention

"X" document of particular relevance; the claimed invention cannot be considered novel or cannot be considered to involve an inventive step when the document is taken alone

"Y" document of particular relevance; the claimed invention cannot be considered to involve an inventive step when the document is combined with one or more other such documents, such combination being obvious to a person skilled in the art

"&" document member of the same patent family

Date of the actual completion of the international search

26 July 2017 (26.07.2017)

Date of mailing of the international search report

26 July 2017 (26.07.2017)

Name and mailing address of the ISA/KR

International Application Division
Korean Intellectual Property Office
189 Cheongsa-ro, Seo-gu, Daejeon, 35208, Republic of Korea

Facsimile No. +82-42-481-8578

Authorized officer

KIM, Jin Ho

Telephone No. +82-42-481-8699



INTERNATIONAL SEARCH REPORT

Information on patent family members

International application No.

PCT/US2017/030562

Patent document cited in search report	Publication date	Patent family member(s)	Publication date
US 2011-0070054 A1	24/03/2011	CA 2713676 A1 CA 2713676 C US 8764368 B2	22/03/2011 14/04/2015 01/07/2014
US 3534867 A	20/10/1970	None	
US 2010-0307401 A1	09/12/2010	CN 101918271 A CN 101918271 B DK 2207713T3 EP 2207713 A1 EP 2207713 B1 KR 10-1533392 B1 KR 10-2010-0071070 A WO 2009-048322 A1	15/12/2010 11/09/2013 17/06/2013 21/07/2010 20/03/2013 02/07/2015 28/06/2010 16/04/2009
US 2011-0044787 A1	24/02/2011	CN 101278103 A CN 101278103 B CN 103089173 A CN 103089173 B EP 1888872 A1 MX 338370 B RU 2007148799 A RU 2405907 C2 UA 91550 C2 US 2006-0285941 A1 US 7832974 B2 US 8215887 B2 WO 2006-128300 A1	01/10/2008 21/11/2012 08/05/2013 09/03/2016 20/02/2008 12/04/2016 20/07/2009 10/12/2010 10/08/2010 21/12/2006 16/11/2010 10/07/2012 07/12/2006
US 2012-0027541 A1	02/02/2012	CA 2712526 A1 CA 2712526 C CA 2815598 A1 CA 2815598 C CN 101925718 A CN 101925718 B MX 2010008457 A MX 339444 B RU 2446267 C1 US 2009-196711 A1 US 8033779 B2 US 8454296 B2 WO 2009-094765 A1	06/08/2009 23/07/2013 06/08/2009 11/08/2015 22/12/2010 20/08/2014 30/08/2010 25/05/2016 27/03/2012 06/08/2009 11/10/2011 04/06/2013 06/08/2009