



⑪ Publication number : **0 443 997 B1**

⑫

EUROPEAN PATENT SPECIFICATION

⑬ Date of publication of patent specification :
30.11.94 Bulletin 94/48

⑭ Int. Cl.⁵ : **H04L 1/00, H03M 13/12,**
H04B 1/10, H04B 7/08

⑮ Application number : **91850015.8**

⑯ Date of filing : **29.01.91**

⑰ **A method of reducing the influence of fading of a Viterbi-receiver having at least two antennas.**

⑱ Priority : **16.02.90 SE 9000566**

⑲ Proprietor : **TELEFONAKTIEBOLAGET L M ERICSSON**
Patent and Trademark Department
S-126 25 Stockholm (SE)

⑳ Date of publication of application :
28.08.91 Bulletin 91/35

㉑ Inventor : **Bäckström, Tomas Olof**
Arhusgatan 81
S-161 41 Kleta (SE)
Inventor : **Kahre, Ragnar Erik**
Rinnbovägen 78
S-244 33 Kävlinge (SE)
Inventor : **Stjernvall, Jan-Erik**
Love Almqvists Väg 19
S-191 44 Sollentuna (SE)

㉒ Publication of the grant of the patent :
30.11.94 Bulletin 94/48

㉓ Designated Contracting States :
AT BE CH DE DK ES FR GB GR IT LI LU NL

㉔ References cited :
EP-A- 0 332 299
US-A- 4 293 798
US-A- 4 847 871

㉕ Representative : **Lövgren, Tage et al**
Telefonaktiebolaget L M Ericsson
Patent and Trademark Department
S-126 25 Stockholm (SE)

EP 0 443 997 B1

Note : Within nine months from the publication of the mention of the grant of the European patent, any person may give notice to the European Patent Office of opposition to the European patent granted. Notice of opposition shall be filed in a written reasoned statement. It shall not be deemed to have been filed until the opposition fee has been paid (Art. 99(1) European patent convention).

Description

TECHNICAL FIELD

The present invention relates to a method for reducing the influence of fading of a Viterbi-receiver having at least two antennas, which receiver receive radio signals over a channel which is liable to disturbance, said method comprising the steps of:

- receiving the signals on the antennas, which are mutually spaced apart,
- sampling signals received from the antennas to received antenna signals,
- forming a channel estimate, an estimate of the channel transmission function, and
- signal processing in the equalizer of the Viterbi-receiver in accordance with the Viterbi-algorithm, where-in symbols are assumed for the state transitions of the Viterbi-algorithm.

BACKGROUND ART

A common problem that occurs in radio transmission of signals is that the signals are extinguished as a result of interference, fading. This problem is evident in mobile radio transmissions in which a mobile receiver moves in an interference field with frequently recurring fading. One known method of reducing the influence of fading is to use a receiver which has two or more mutually spaced antennas, for instance as described in Electronics Letters, 20th July 1989, Vol. 25, No. 15, L.B. Lopes: Combined Space/Time Diversity Technique for Narrowband TDMA Mobile Radio Systems. A transmitted digital radio signal is received by a first antenna and is delayed in time by a suitable selected time interval. The radio signal is also received by a second antenna whose signal is added to the delayed signal and the summated signal is processed in an equalizer, which may be a Viterbi-equalizer. The article discloses that the bit error content decreases in accordance with the length of the delay interval. An alternative method is one of using receivers that are equipped with several antennas, as described in Mobile Communications Design Fundamentals by William C.Y. Lee, Howard W. Sams & Co, Indiana, USA. In section 3.5.1 of this book several examples are given as to how signals from two receiver amplifiers with separate antennas can be added in order to counteract fading. In the case of digital signal transmission this addition results in the difficulty of necessitating phase correct addition of the signals. The signals received by the individual antennas may be in counter-phase and extinguish one another, even when the signals received by the antennas have a satisfactorily high strength. Consequently, it is necessary to phase-lock the signals, which is difficult to achieve, particularly with a rapidly fading channel which is subjected to noise disturbances. Slow, variable phase-locking is used advantageously in the case of such noise disturbances, whereas the rapid fading requires rapid, variable phase locking.

DISCLOSURE OF THE INVENTION

The aforementioned problems of processing in a receiver signals which are obtained from mutually separate antennas in order to reduce to effect of fading is solved in the following manner in accordance with the invention. There is estimated for each antenna a transmission function for the channel extending to the antenna. There is calculated for each state transition between an old and a new state in the Viterbi-algorithm a part metric value for each antenna signal, with the aid of respective channel estimates. The part metric values for individual antenna signals are mutually weighted and used to calculate the metric values at the transition between the old and the new state.

The invention is characterized by the features set forth in the following claims.

BRIEF DESCRIPTION OF THE DRAWINGS

An exemplifying embodiment of the invention will now be described in more detail with reference to the accompanying drawings, in which

Figure 1 illustrates schematically a radio transmission system comprising a transmitter, a receiver and an intermediate disturbed channel;

Figure 2 illustrates time slots for a time shared transmission system, and a time slot signal sequence;

Figure 3 is a diagram which illustrates the individual values of a transmitted symbol;

Figure 4 illustrates a mobile receiver which moves in a signal interference pattern between two buildings;

Figure 5 is a block schematic illustrating a receiver which processes signals in accordance with the inventive method; and

Figure 6 is a block schematic which illustrates parts of the receiver in Figure 5 in more detail.

BEST MODE OF CARRYING OUT THE INVENTION

A radio transmission system for time shared radio communication is illustrated schematically in Figure 1. A transmitter has a unit 1 which receives an information carrying signal and generates corresponding digital symbols g . These symbols are subjected to digital/analog conversion and modulation and are transmitted as an analogue signal Y from a unit 2, in accordance with known techniques. The signal Y is intercepted by a receiver having receiving units 3 which are R in number. Each of the receiving units has an antenna 4 and is connected to a respective analogue/digital converter 5. These converters convert the signals received from the antennas 4 to received antenna signals $s_{m,r}(k)$. The reference k identifies a sampling time point with number k , while reference r indicates that the signal arrives from the r :th antenna, $1 \leq r \leq R$. The received antenna signals $s_{m,r}(k)$ are sent to a unit 6 in which signals are processed in accordance with the inventive method. The unit 6 includes means which carry out the Viterbi-algorithm and means for estimating a channel transmission function. The unit produces estimated symbols \hat{g} which correspond to the digital symbols g . The transmitted signal Y is disturbed during transmission, among other things by fading, the disturbing influence of which on the estimated symbols \hat{g} is reduced in the receiver. This is achieved by the fact that the antennas 4 are at least two in number, $R \geq 2$, and in that the received antenna signals $s_{m,r}(k)$ are processed in accordance with the inventive method in the unit 6, as described in more detail herebelow.

As beforementioned, the radio transmission system according to the present embodiment is time-shared with separate time slots 1-N according to Figure 2, in which t represents time. Each time slot f can transmit a signal sequence SS , which includes a synchronizing sequence SO and a data sequence DO containing the information to be transmitted. The signal sequence SS contains binary information, although the aforesaid symbols can be modulated in accordance with quadrature modulation for instance, as illustrated in Figure 3. In a complex numeric plan with the axes referenced I and Q , the four possible values of the modulated symbols are marked one in each quadrant with the binary number 00, 01, 10 or 11. That time taken to transmit one such modulated symbol is designated symbol time TS .

The aforesaid signal fading, so-called Rayleigh-fading, occurs in the following manner. Figure 4 illustrates two buildings 7 and 8 which reflect the transmitted signal Y . The reflected signals interfere with one another between the buildings and, as a result of a phase shift, there may occur a regular interference pattern with alternating bulges and nodes of the signal strength. A mobile receiver 9 which moves through the interference pattern will repeatedly pass the nodes where the signal strength is very low. A more exhaustive description of signal fading is given in the aforesaid reference Mobile Communications Design Fundamentals by William C.Y. Lee, Chapter 1.

The aforesaid unit 6 is illustrated in more detail in Figure 5, where for the sake of simplicity the number of antennas R has been restricted to three. The Figure also shows a block 10 which symbolizes a transmission function h for the actual transmission channel which influences the digital signal g . The transmission function h includes the transmitting units 2, the radio transmission of the signal Y , the receiving units 3 and the analogue/digital converters 5. The unit 6 includes a symbol sequence generator 9, channel estimating circuits 17 for the respective antennas 4, a metric calculating unit 11 and an analyzer 12 which effects signal processing in accordance with the Viterbi-algorithm. A part channel estimate $h_{est,r}$ is calculated in each of the channel estimating circuits 17. Each part channel estimate is calculated in a known manner, by comparing the synchronizing sequence SO generated by the symbol sequence generator 9 with the received antenna signals $s_{m,r}(k)$ for the transmitted synchronizing sequence SO . It is assumed in the present embodiment that the part channel estimates $h_{est,r}$ are calculated once with each signal sequence SS , with the aid of the synchronizing sequence SO , and are held constant during the data sequence DO . It is possible, however, to adapt the part channel estimates $h_{est,r}$ in a known manner, for instance in the manner described in IEEE Transactions on Information Theory, January 1973, F.R. Megee Jr. and J.G. Proakis: Adaptive Maximum-Likelihood Sequence Estimation for Digital Signaling in the Presence of Intersymbol Interference.

When the data sequence DO is transmitted, the received antenna signals $s_{m,r}(k)$ are obtained for the information to be transmitted. These signals are analyzed in accordance with the aforesaid Viterbi-algorithm, which has a number of states $M=V^D-1$. V designates a number of values which a symbol can assume, this value being $V=4$ in the case of the symbols shown in Figure 3. D designates the time dispersion for the transmission channel in the number of symbol times TS and it is assumed in the illustrated embodiment that D equals 2. This means that the Viterbi-algorithm shall have $M=3$ states in which it is able to carry out the desired processing of the received antenna signals $s_{m,r}(k)$. A more detailed description of the Viterbi-algorithm is given, for instance, in Proceeding of the IEEE, Vol. 61, No. 3, March 1973, G.D. Forney, Jr.: The Viterbi Algorithm. The symbol sequence generator 9 assumes sequences of symbols $S(\Delta T_{ij})$ for a state transition ΔT_{ij} in the Viterbi-algorithm from an old state T_j to a new state T_i . With the aid of the channel estimates $h_{est,r}$, assumed input signals are calculated in accordance with a relationship

$$s_{a,r}(\Delta T_j, k) = h_{est,r} * S(\Delta T_j)$$

in which the symbol * indicates a convolution. The part metric values $m_r(\Delta T_j, k)$ for a future selection of the state transition ΔT_j is calculated with the aid of the assumed input signals $s_{a,r}(\Delta T_j, k)$ and the received antenna signals $s_{in,r}(k)$, as will be described with reference to Figure 6.

This Figure illustrates the Viterbi-analyzer 12 and the metric calculating unit 11. This unit includes for each of the part channel estimates $h_{est,r}$ an arithmetic circuit 13 and a coefficient circuit 14. The arithmetic circuits 13 function to calculate the part metric values in accordance with a relationship

$$m_r(\Delta T_j, k) = |s_{in,r}(k) - s_{a,r}(\Delta T_j, k)|^2$$

Similar to the foregoing, the reference k designates an indicated sampling time, the index r designates one of the antennas, and ΔT_j designates the state transitions according to the Viterbi algorithm. In the case of the illustrated embodiment, this algorithm has $M=4$ states designated by binary numbers 00, 01, 10, 11, having four transitions to each new state, as illustrated in the Figure, and thus a total of 16 state transitions. A metric value is calculated for each of these state transitions in accordance with a relationship

$$M(\Delta T_{ij}, k) = M(T_j, k-1) + \sum_{r=1}^R K_r \cdot m_r(\Delta T_{ij}, k)$$

K_r designates, in this case, the coefficients in the circuits 14 and the weighted summation is carried out in a summator 15 for all of the R antennas. In accordance with the Viterbi algorithm, the magnitude $M(T_j, k-1)$ relates to a selected metric value for the old state T_j at a sampling time point $k-1$ one symbol time TS prior to the indicated sampling point k . The old metric value is increased with the weighted sum of the part metric values in a summator 16. According to the Viterbi algorithm there is selected the smallest of the metric values at the transition to the new state T_i , according to a relationship

$$M(T_j, k) = \text{Min}_i (M(\Delta T_{ij}, k))$$

The metric value $M(T_j, k)$ is thus the value selected for the new state at the indicated sampling time point k . The metric value $M(T_j, k)$ is used in accordance with the Viterbi algorithm, in order to determine the estimated symbols \hat{s} . The metric value is also stored for continued calculation of the metric values at the subsequent sampling time point $k+1$.

The coefficients K_r for weighting the part metric values can be selected in various ways. According to one simple alternative, all of the coefficients are constant and mutually equal and in the case of the example illustrated in Figure 8 where $R=3$, K_r will equal $P/3$ where P is a chosen constant. This method implies that the radio signal on one of the antennas 4 with fully developed fading will have the same weighting in the metric calculation as the signal on one of the antennas where the signal strength is good. According to a more complicated alternative, the strength of the received antenna signals according to $s_{in,r}(k)$ is measured by a control circuit 18 and the value of the coefficients K_r are assumed by the control circuit in dependence on this signal strength. According to one advantageous embodiment, K_r is proportional to the energy in respective received antenna signals $K_r = c \cdot |s_{in,r}(k)|^2$. In this case, c designates a constant which is chosen so that the sum of the coefficients $\sum K_r$ will equal P in accordance with the foregoing.

The invention has been described with reference to a time shared system for radio communication. It is possible, however, to apply the invention also to other systems, for instance systems for frequency shared radio communication. In such systems it is sufficient to transmit a synchronizing sequence used in forming a channel estimate once at the beginning of a message. The channel estimate is thereafter adapted during the whole of the message, with the aid of the signal transmitted unbrokenly during this time period. If there is limited demand on the speed of the system, it is also possible to form a channel estimate in the complete absence of a synchronizing sequence, for instance in the manner described in IEEE Transactions on Communications, Vol. COM-28, No. 11, November 1980, D.N. Godard: "Self-Recovering Equalization and Carrier Tracking in Two-Dimensional Data Communication System".

Claims

1. A method for reducing the influence of fading of a Viterbi-receiver having at least two antennas, which receiver receive radio signals over a channel which is liable to disturbance, said method comprising the steps of:
- receiving the signals on the antennas, which are mutually spaced apart,
 - sampling signals received from the antennas to received antenna signals,
 - forming a channel estimate, an estimate of the channel transmission function, and
 - signal processing in the equalizer of the Viterbi-receiver in accordance with the Viterbi-algorithm, wherein symbols are assumed for the state transitions of the Viterbi-algorithm, characterized in that the channel estimate includes at least two (R) part channel estimates ($h_{est,r}$) belonging to individual antennas (4), wherein the method in an indicated sampling time point (k) includes the further steps of:
 - forming assumed input signals ($s_{a,r}(\Delta T_{ij},k)$) from the assumed symbols (S(ΔT_{ij})) with the aid of the part channel estimates ($h_{est,r}$), wherein an assumed input signal ($s_{a,r}(\Delta T_{ij},k)$) for the individual part channel estimates ($h_{est,r}$) is formed for each state transition (ΔT_{ij}) of the Viterbi-algorithm,
 - forming part metric values ($m_r(\Delta T_{ij},k)$) for the individual part channel estimates ($h_{est,r}$) in dependence on the received antenna signal ($s_{n,r}(k)$) which belongs to the part channel estimate and the corresponding assumed input signals ($s_{a,r}(\Delta T_{ij},k)$),
 - forming for an indicated state transition (ΔT_{ij}) between an old (T_j) and a new (T_i) state in the Viterbi-algorithm a metric value ($M(\Delta T_{ij},k)$), such as a metric value ($M(T_j,k-1)$) chosen in accordance with the Viterbi-algorithm for the old state (T_j) at a sampling time point (k-1) preceding the indicated sampling time point (k) increased with a weighted (K_r) sum of the part metric values ($m_r(\Delta T_{ij},k)$) belonging to the individual part channel estimates ($h_{est,r}$), and
 - forming metric values, corresponding to the metric value ($M(\Delta T_{ij},k)$) for the indicated state transition (ΔT_{ij}), for all state transitions (ΔT_{ij}) to the new state (T_i) and selecting, in accordance with the Viterbi-algorithm, the smallest ($M(T_j,k)$) of these metric values ($M(\Delta T_{ij},k)$) at the transition to the new state (T_i).
2. A method according to Claim 1, characterized by forming the individual part metric values ($m_r(\Delta T_{ij},k)$) in dependence on an absolute value of the difference between the received antenna signal ($s_{n,r}(k)$) and the corresponding assumed input signals ($s_{a,r}(\Delta T_{ij},k)$).
3. A method according to Claim 1 or Claim 2, characterized in that all of the coefficients (K_r) for the weighting of the part metric values ($m_r(\Delta T_{ij},k)$) have mutually the same values ($K_r=P/R$).
4. A method according to Claim 1 or Claim 2, characterized by choosing the coefficients (K_r) for the weighting of the part metric values ($m_r(\Delta T_{ij},k)$) in dependence on the amplitude of the corresponding received antenna signals ($s_{n,r}(k)$).
5. A method according to Claim 4, characterized in that the coefficients (K_r) for the weighting of the part metric values ($m_r(\Delta T_{ij},k)$) are proportional (c) to the energy of the received antenna signals ($s_{n,r}(k)$).

Patentansprüche

1. Verfahren zur Verminderung des Fadingeinflusses auf einen Viterbi-Empfänger mit mindestens zwei Antennen, wobei der Empfänger Funksignale über einen Kanal empfängt, der Störungen unterworfen ist und das Verfahren die Schritte aufweist:
- Empfangen des Signals an den Antennen die wechselseitig beabstandet sind,
 - Abtasten von den Antennen empfangener Signale in empfangene Antennensignale,
 - Bilden einer Kanalabschätzung, einer Abschätzung der Kanalübertragungsfunktion, und Verarbeiten des Signals in dem Entzerrer des Viterbi-Empfängers nach dem Viterbi-Algorithmus, wobei Symbole für die Zustandsübergänge des Viterbi-Algorithmus angenommen werden, dadurch gekennzeichnet, daß die Kanalabschätzung mindestens zwei (R) zu individuellen Antennen (4) zugehörige Teil-Kanalabschätzungen ($h_{est,r}$) einschließt, wobei das Verfahren zu einem angegebenen Abtastzeitpunkt (k) die weiteren Schritte einschließt:

- Bilden angenommener Eingangssignale ($s_{a,r}(\Delta T_{ij},k)$) aus den angenommenen Symbolen ($s(\Delta T_{ij})$) mit Hilfe der Teil-Kanalabschätzungen ($h_{est,r}$), wobei ein angenommenes Eingangssignal ($s_{a,r}(\Delta T_{ij},k)$) für die individuellen Teil-Kanalabschätzungen ($h_{est,r}$) für jeden Zustandsübergang (ΔT_{ij}) des Viterbi-Algorithmus gebildet wird,
- Bilden teilmetrischer Werte ($m_r(\Delta T_{ij},k)$) für die individuellen Kanalabschätzungen ($h_{est,r}$) in Abhängigkeit von dem empfangenen Antennensignal $S_{in,r}(k)$, welches zu der Teil-Kanalabschätzung und den entsprechenden angenommenen Eingangssignalen ($s_{a,r}(\Delta T_{ij},k)$) gehört,
- Bilden eines metrischen Wertes ($M((\Delta T_{ij},k)$) für einen angegebenen Zustandsübergang (ΔT_{ij}) zwischen einem alten (T_j) und einem neuen (T_i) Zustand im Viterbi-Algorithmus, wie beispielsweise eines metrischen Wertes ($M((\Delta T_{ij},k-1)$), der gemäß dem Viterbi-Algorithmus für den alten Zustand (T_j) zu einem Abtastzeitpunkt ($k-1$), der dem angegebenen Abtastzeitpunkt (k) vorhergeht, gewählt wurde, der mit einer gewichteten (K_r) Summe der teilmetrischen Werte ($m_r(\Delta T_{ij},k)$), welche zu den individuellen Teil-Kanalabschätzungen ($h_{est,r}$) gehören, vergrößert ist, und
- Bilden metrischer Werte, welche dem metrischen Wert ($M(\Delta T_{ij},k)$) für den angegebenen Zustandsübergang (ΔT_{ij}) entsprechen, für alle Zustandsübergänge (ΔT_{ij}) auf den neuen Zustand (T_i) und Auswählen des kleinsten Wertes ($M(T_i,k)$) dieser metrischen Werte ($M(\Delta T_{ij},k)$) am Übergang zu dem neuen Zustand (T_i) nach dem Viterbi-Algorithmus.

2. Verfahren nach Anspruch 1, dadurch gekennzeichnet, daß die individuellen teilmetrischen Werte ($m_r(\Delta T_{ij},k)$) in Abhängigkeit von einem absoluten Wert der Differenz zwischen dem empfangenen Antennensignal ($s_{in,r}(k)$) und den entsprechenden angenommenen Eingangssignalen ($s_{a,r}(\Delta T_{ij},k)$) gebildet werden.
3. Verfahren nach Anspruch 1 oder Anspruch 2, dadurch gekennzeichnet, daß alle Koeffizienten (K_r) für die Wichtung der teilmetrischen Werte ($m_r(\Delta T_{ij},k)$) wechselseitig dieselben Werte ($K_r = P/R$) aufweisen.
4. Verfahren nach Anspruch 1 oder Anspruch 2, dadurch gekennzeichnet, daß die Koeffizienten (K_r) für die Wichtung der teilmetrischen Werte ($m_r(\Delta T_{ij},k)$) in Abhängigkeit von der Amplitude des entsprechenden empfangenen Antennensignals $S_{in,r}(k)$ gewählt werden.
5. Verfahren nach Anspruch 4, dadurch gekennzeichnet, daß die Koeffizienten (K_r) für die Wichtung der teilmetrischen Werte ($m_r(\Delta T_{ij},k)$) proportional (c) zu der Energie des empfangenen Antennensignals $s_{in,r}(k)$ sind.

Revendications

1. Un procédé pour réduire l'influence de l'évanouissement dans un récepteur de Viterbi ayant au moins deux antennes, ce récepteur recevant des signaux radioélectriques sur un canal qui est sujet à des perturbations, ce procédé comprenant les étapes suivantes :
 - on reçoit les signaux sur les antennes, qui sont mutuellement espacées,
 - on échantillonne les signaux reçus à partir des antennes, pour donner des signaux d'antenne reçus,
 - on forme une estimation de canal, qui est une estimation de la fonction de transmission du canal, et
 - on effectue dans l'égaliseur du récepteur de Viterbi un traitement de signal, conformément à l'algorithme de Viterbi, dans lequel on suppose des symboles pour les transitions d'états de l'algorithme de Viterbi,
 caractérisé en ce que l'estimation de canal comprend au moins deux (R) estimations de canal partielles ($h_{est,r}$) appartenant à des antennes individuelles (4), le procédé comprenant les étapes supplémentaires suivantes, à un instant d'échantillonnage indiqué (k) :
 - on forme des signaux d'entrée supposés ($s_{a,r}(\Delta T_{ij},k)$) à partir des symboles supposés ($S(\Delta T_{ij})$), à l'aide des estimations de canal partielles ($h_{est,r}$), un signal d'entrée supposé ($s_{a,r}(\Delta T_{ij},k)$) pour les estimations de canal partielles individuelles ($h_{est,r}$) étant formé pour chaque transition d'états (ΔT_{ij}) de l'algorithme de Viterbi,
 - on forme des valeurs de métrique partielle ($m_r(\Delta T_{ij},k)$) pour les estimations de canal partielles individuelles ($h_{est,r}$), sous la dépendance du signal d'antenne reçu ($s_{in,r}(k)$) qui correspond à l'estimation de canal partielle et aux signaux d'entrée supposés correspondants ($s_{a,r}(\Delta T_{ij},k)$),
 - on forme pour une transition d'états indiquée (ΔT_{ij}) entre un ancien état (T_j) et un nouvel état (T_i) dans l'algorithme de Viterbi, une valeur de métrique $M(\Delta T_{ij},k)$, telle qu'une valeur de métrique

($M(T_j, k-1)$) choisie conformément à l'algorithme de Viterbi pour l'ancien état (T_j) à un instant d'échantillonnage ($k-1$) qui précède l'instant d'échantillonnage indiqué (k), augmentée par une somme pondérée (K_r) des valeurs de métrique partielle ($m_r(\Delta T_{ij}, k)$) correspondant aux estimations de canal partielles individuelles ($h_{e,r}$), et

- on forme des valeurs de métrique, correspondant à la valeur de métrique ($M(\Delta T_{ij}, k)$) pour la transition d'état indiquée (ΔT_{ij}), pour toutes les transitions d'états (ΔT_{ij}) vers le nouvel état (T_i) et on sélectionne, conformément à l'algorithme de Viterbi, la plus petite ($M(T_j, k)$) de ces valeurs de métrique ($M(\Delta T_{ij}, k)$) à la transition vers le nouvel état (T_i).

2. Un procédé selon la revendication 1, caractérisé en ce qu'on forme les valeurs de métrique partielle individuelles ($m_r(\Delta T_{ij}, k)$) sous la dépendance d'une valeur absolue de la différence entre le signal d'antenne reçu ($s_{in,r}(k)$) et les signaux d'entrée supposés correspondants ($s_{e,r}(\Delta T_{ij}, k)$).
3. Un procédé selon la revendication 1 ou la revendication 2, caractérisé en ce que tous les coefficients (K_r) pour la pondération des valeurs de métrique partielle ($m_r(\Delta T_{ij}, k)$) ont mutuellement les mêmes valeurs ($K_r = P/R$).
4. Un procédé selon la revendication 1 ou la revendication 2, caractérisé en ce qu'on choisit les coefficients (K_r) pour la pondération des valeurs de métrique partielle ($m_r(\Delta T_{ij}, k)$) sous la dépendance de l'amplitude des signaux d'antenne reçus correspondants ($s_{in,r}(k)$).
5. Un procédé selon la revendication 4, caractérisé en ce que les coefficients (K_r) pour la pondération des valeurs de métrique partielle ($m_r(\Delta T_{ij}, k)$) sont proportionnelles (c) à l'énergie des signaux d'antenne reçus ($s_{in,r}(k)$).

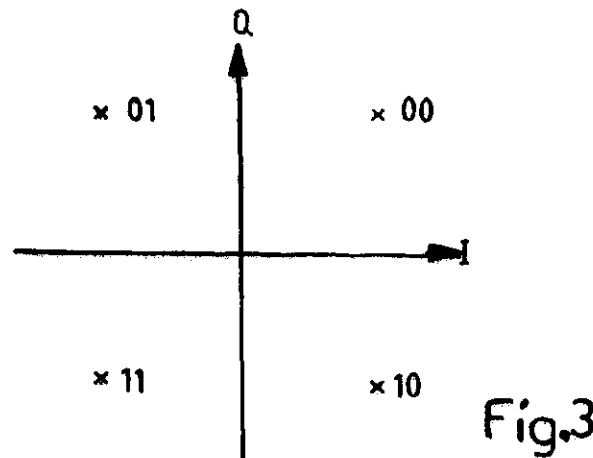
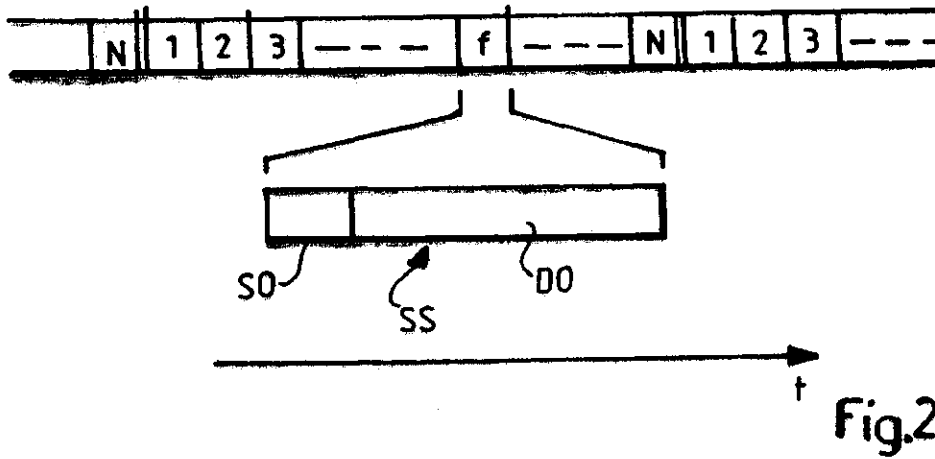
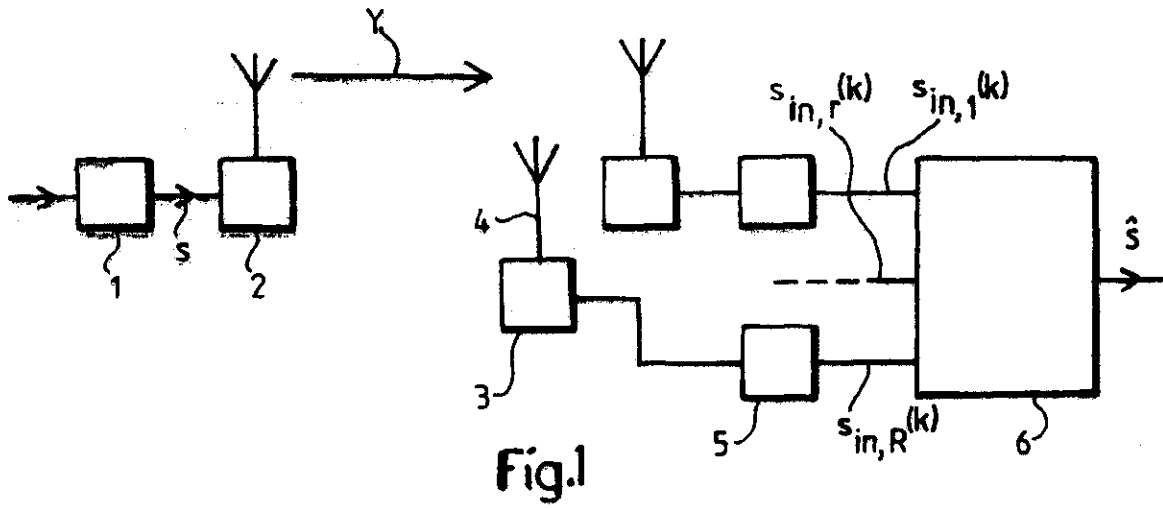

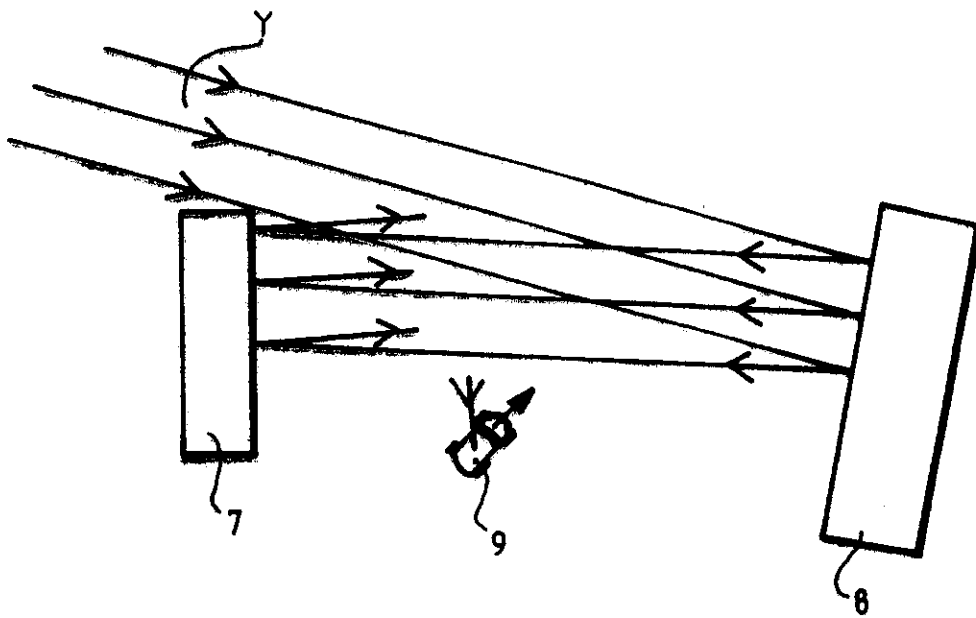

Fig.4

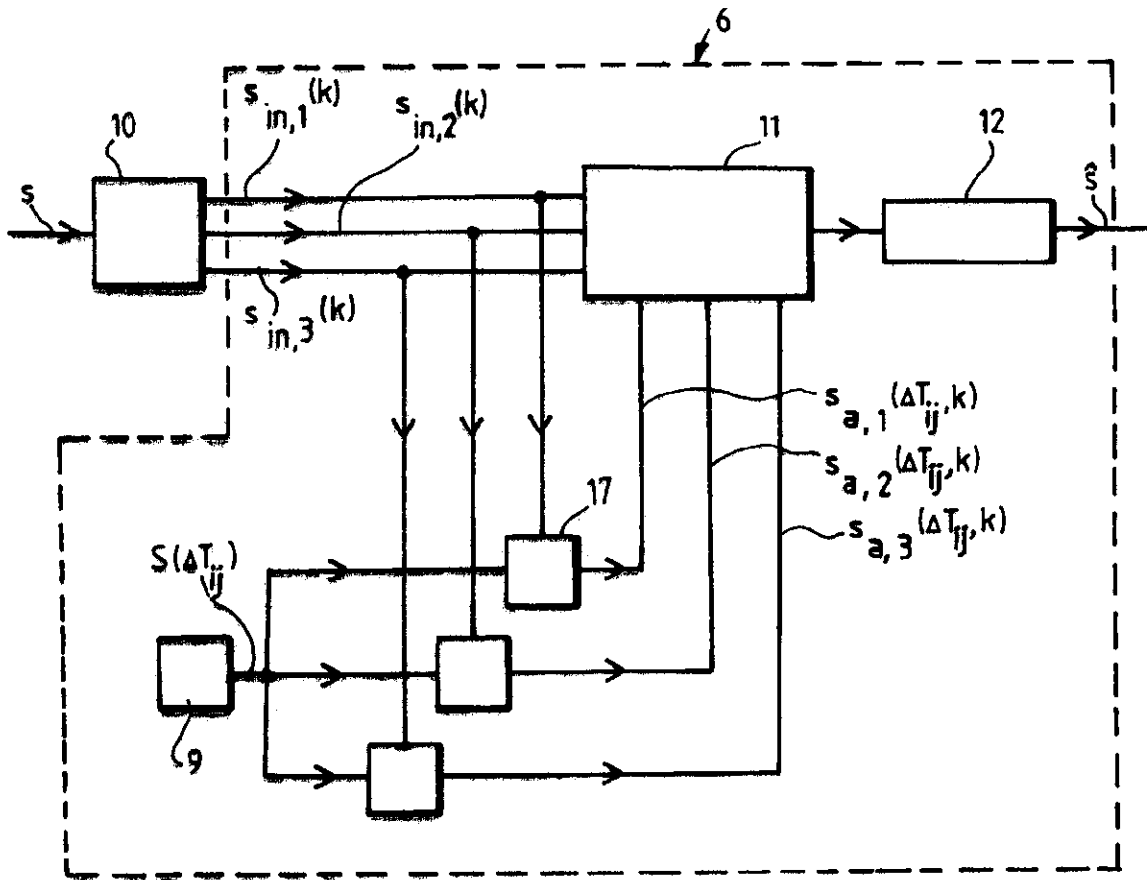

Fig.5

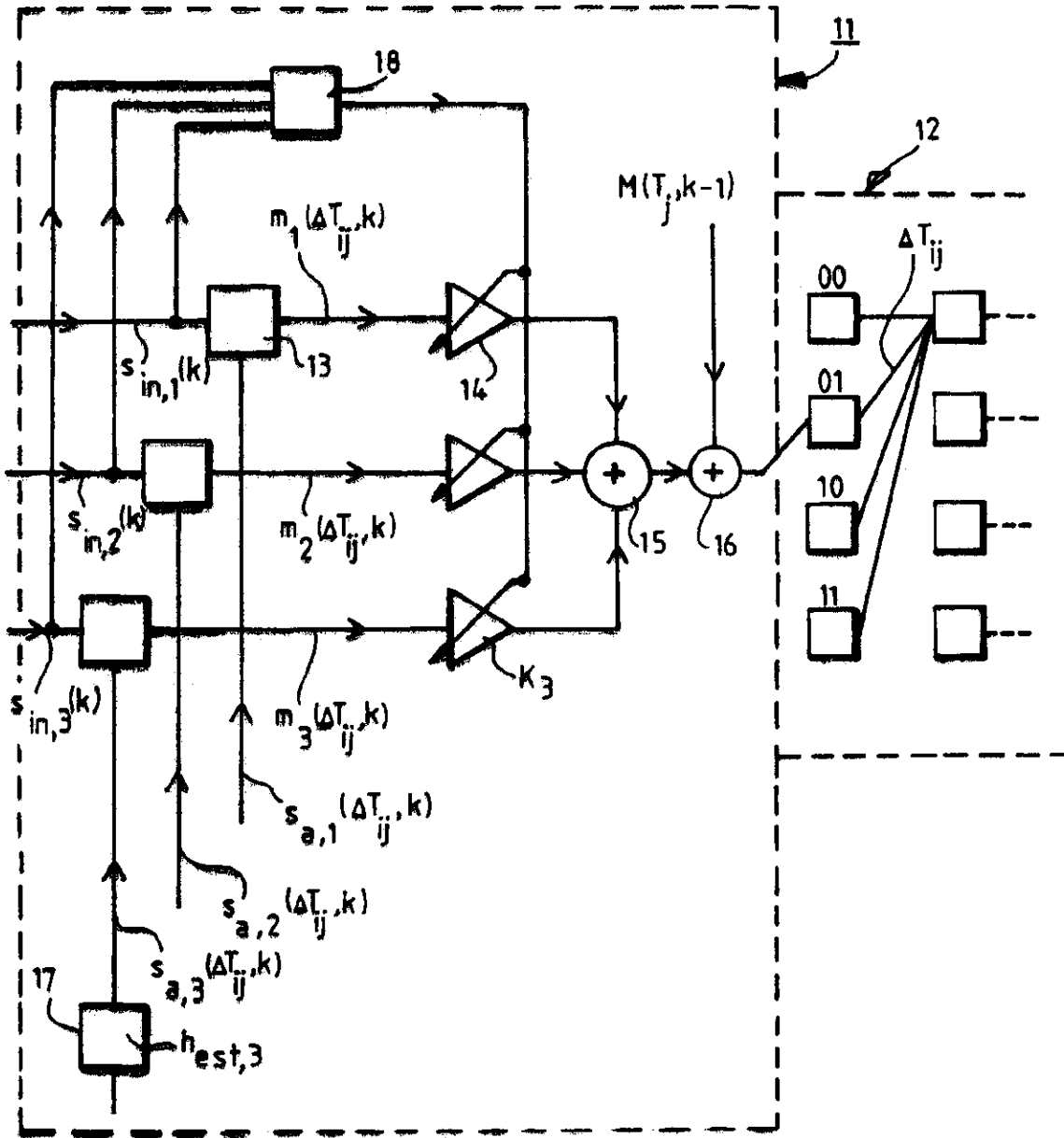

Fig.6

REGISTER ENTRY FOR EP0443997

European Application No EP91850015.8 filing date 29.01.1991

Priority claimed:

16.02.1990 in Sweden - doc: 9000566

Designated States BE CH DE DK ES FR GB GR IT LI LU NL AT

Title A METHOD OF REDUCING THE INFLUENCE OF FADING OF A VITERBI RECIEVER
HAVING AT LEAST TWO ANTENNAS.

Applicant/Proprietor

TELEFONAKTIEBOLAGET L M ERICSSON, S-126 25 Stockholm, Sweden

[ADP No. 50239789001]

Inventors

TOMAS OLOF BÄCKSTRÖM, Arhusgatan 81, S-161 41 Kista, Sweden

[ADP No. 58878919001]

RAGNAR ERIK KAHRE, Rinnbovägen 78, S-244 33 Kävlinge, Sweden

[ADP No. 58878927001]

JAN-ERIK STJERNVALL, Love Almqvists Väg 19, S-191 44 Sollentuna, Sweden

[ADP No. 58878935001]

Classified to

H04L H03M H04B

Address for Service

HASELTINE LAKE & CO, Hazlitt House, 28 Southampton Buildings, Chancery

Lane, LONDON, WC2A 1AT, United Kingdom

[ADP No. 00000034001]

EPO Representative

TAGE LÖVGREN, Telefonaktiebolaget L M Ericsson Patent and Trademark

Department, S-126 25 Stockholm, Sweden

[ADP No. 58362526001]

Publication No EP0443997 dated 28.08.1991

Publication in English

Examination requested 21.01.1992

Patent Granted with effect from 30.11.1994 (Section 25(1)) with title A METHOD
OF REDUCING THE INFLUENCE OF FADING OF A VITERBI-RECEIVER HAVING AT LEAST
TWO ANTENNAS.

24.06.1994 HASELTINE LAKE & CO, Hazlitt House, 28 Southampton Buildings,
Chancery Lane, LONDON, WC2A 1AT, United Kingdom

[ADP No. 00000034001]

registered as address for service

Entry Type 8.11 Staff ID. DD1 Auth ID. AA

TIMED: 13/12/94 15:37:39

REGISTER ENTRY FOR EP0443997 (Cont.)

PAGE: 2

28.10.1994 Notification from EPO of change of Applicant/Proprietor details
from

TELEFONAKTIEBOLAGET L M ERICSSON, S-126 25 Stockholm, Sweden

[ADP No. 50239789001]

to

TELEFONAKTIEBOLAGET L M ERICSSON, Patent and Trademark Department,

S-126 25 Stockholm, Sweden

[ADP No. 50239789001]

Entry Type 25.14 Staff ID. RD06 Auth ID. EPT

**** END OF REGISTER ENTRY ****

OA80-01
EP

OPTICS - PATENTS

13/12/94 15:38:12
PAGE: 1

RENEWAL DETAILS

PUBLICATION NUMBER

EP0443997

PROPRIETOR(S)

TELEFONAKTIEBOLAGET L M ERICSSON, Patent and Trademark Department,
S-126 25 Stockholm, Sweden

DATE FILED

29.01.1991

DATE GRANTED

30.11.1994

DATE NEXT RENEWAL DUE

28.02.1995

DATE NOT IN FORCE

DATE OF LAST RENEWAL

YEAR OF LAST RENEWAL

00

STATUS

PATENT IN FORCE