



(11) **EP 1 564 497 B1**

(12) **EUROPEAN PATENT SPECIFICATION**

(45) Date of publication and mention of the grant of the patent:  
**27.08.2008 Bulletin 2008/35**

(51) Int Cl.:  
**F24C 15/02<sup>(2006.01)</sup>**

(21) Application number: **04027019.1**

(22) Date of filing: **12.11.2004**

(54) **Door opening/closing apparatus for electric oven**

Öffnungs- und Schliesssystem für eine Ofentür

Système d'ouverture-fermeture pour porte d'un four

(84) Designated Contracting States:  
**DE ES FR GB**

(30) Priority: **16.02.2004 KR 2004010015**  
**25.02.2004 KR 2004004925**

(43) Date of publication of application:  
**17.08.2005 Bulletin 2005/33**

(73) Proprietor: **LG ELECTRONICS INC.**  
**Seoul (KR)**

(72) Inventor: **Kim, Hag Sin**  
**Kimhae-si**  
**Kyungsangnam-do (KR)**

(74) Representative: **Henkel, Feiler & Hänzler**  
**Patentanwälte**  
**Maximiliansplatz 21**  
**80333 München (DE)**

(56) References cited:  
**EP-A- 0 617 235** **US-A- 4 764 648**  
**US-A- 5 493 099**

**EP 1 564 497 B1**

Note: Within nine months of the publication of the mention of the grant of the European patent in the European Patent Bulletin, any person may give notice to the European Patent Office of opposition to that patent, in accordance with the Implementing Regulations. Notice of opposition shall not be deemed to have been filed until the opposition fee has been paid. (Art. 99(1) European Patent Convention).

**Description****BACKGROUND OF THE INVENTION****Field of the Invention**

**[0001]** The present invention relates to a door opening/closing apparatus in an electric oven, and more particularly, to a door opening/closing apparatus in an electric oven, capable of exactly indicating a door's opening/closing status of the electric oven and safely shielding a cavity when the door is closed. Further, the present invention relates to a door opening/closing apparatus in an electric oven, wherein the electric oven is not operated upon inadvertent use of a user so that the electric oven may be more safely used.

**Description of the Related Art**

**[0002]** Generally, an electric oven is an apparatus for cooking foods by heating an electric heater with foods put in an inside of a cavity. The electric oven can perform a grill or oven function using radiant heat of the electric heater or convectional hot blast of a convection fan. Also, in case a magnetron is additionally provided, an electromagnetic wave generated from the magnetron is radiated to an inside of the cavity, whereby food cooking may be swiftly performed even more.

**[0003]** Generally, a door is formed on a front side of the electric oven and a door's opening/closing operation in an up/down direction is performed by a hinge provided to a lower portion of the door. A latch is formed on an upper portion of the door and inserted into and hooked at a latch receiving hole provided to a front side of a main machine of the electric oven, so that a closed state of the door can be stably maintained. When a user intends to open the door, the latch is released by a predetermined mechanism so that a user can open the door. Further, it is known that a predetermined door switch for detecting that the latch is inserted into the latch receiving hole is provided, so that if the latch is inserted into the latch receiving hole, the door is judged to have been closed' and the electric oven starts to operate and if the latch is not inserted, the electric oven does not operate even if a start button is pressed.

**[0004]** In the meantime, there are following problems in using the above-described general electric oven of the related art. When temperature in an inside of the cavity reaches a high temperature and a user who does not yet recognize the high temperature opens the door, there is a danger of getting burned. To prevent such a danger, another related art of United States Patent No. 6,315,336 entitled "motorized self-cleaning oven latch" has been suggested. However, the above US patent is difficult to realize and the manufacturing cost is raised due to its complicated structure.

**[0005]** Further, even a case that a careless user inadvertently inserts a long rod into the latch receiving hole,

the related art electric oven may detect the case as a door-closed state. In that case, the electric oven may operate unexpectedly and the user may get burned. Still further, if the case described above occurs when the oven is overheated, there is a danger that a fire may break out.

**[0006]** EP-A-0617235 discloses an oven with a door and a device for locking the door. The device includes a hook pivoting about a spindle under the action of the sliding movement of a slider shifted linearly at the side of the cavity and engaging a protrusion of the hook opposite the engaging section. The hook selectively engages a locking piece positioned at the outer periphery of the door of the oven. The slider is linearly moved by means of a motor equipped with a cam inserted into an opening of the slider. The motor is caused to start if the temperature within the oven is higher than a set-point temperature.

**SUMMARY OF THE INVENTION**

**[0007]** It is an object of the present invention to provide an electric oven including a door opening/closing apparatus that operates in a reliable manner and safely avoids damage to a user's body that may be generated due to an inadvertent use, or a danger of a fire that may be broken out in a room due to a high temperature generated from the electric oven.

**[0008]** Further, an aspect of the present invention is to provide a door opening/closing apparatus for an electric oven, capable of reducing manufacturing costs and enhancing convenience in product application even more by simplifying a structure of the door opening/closing apparatus of the electric oven.

**[0009]** Additional advantages, objects, and features of the invention will be set forth in part in the description which follows and in part will become apparent to those having ordinary skill in the art upon examination of the following or may be learned from practice of the invention. The objectives and other advantages of the invention may be realized and attained by the structure particularly pointed out in the written description and claims hereof as well as the appended drawings.

**[0010]** To achieve these objects and other advantages and in accordance with the purpose of the invention, as embodied and broadly described herein, an electric oven with a door opening/closing apparatus has the features of claim 1.

**[0011]** According to the present invention, operational safety of the electric oven where high temperature is generated can be enhanced even more. Further, the door opening/closing apparatus is more reliably realized, so that user's convenience of the electric oven can be promoted even more.

**[0012]** Particularly, according to the present invention, damage on a user's body due to an inadvertent use, or a danger of a fire can be reduced.

**[0013]** Further, a structure of the door opening/closing apparatus of the electric oven is simplified, whereby manufacturing cost is reduced and convenience is increased

upon application of the electric oven.

[0014] It is to be understood that both the foregoing general description and the following detailed description of the present invention are exemplary and explanatory and are intended to provide further explanation of the invention as claimed.

### **BRIEF DESCRIPTION OF THE DRAWINGS**

[0015] The accompanying drawings, which are included to provide a further understanding of the invention and are incorporated in and constitute a part of this application, illustrate embodiment(s) of the invention and together with the description serve to explain the principle of the invention. In the drawings:

[0016] Fig. 1 is a perspective view of an electric oven to which the present invention is applied;

[0017] Fig. 2 is a cross-sectional view, taken along line I-I' of Fig. 1, and illustrating a construction of a latch;

[0018] Fig. 3 is a cross-sectional view, taken along line II-II' of Fig. 1;

[0019] Fig. 4 is a view illustrating a state before a latch is not inserted in a second door opening/closing structure;

[0020] Fig. 5 is a view illustrating a state in which a latch is inserted to some extent and a first micro-switch is switched on;

[0021] Fig. 6 is a view illustrating a state in which a latch is inserted completely and both a first and a second micro-switches are switched on;

[0022] Figs. 7 and 8 are views illustrating that an alien material is inserted into the second door opening/closing structure;

[0023] Fig. 9 is a cross-sectional view, taken along line III-III' of Fig. 1;

[0024] Fig. 10 is a side view of a first door opening/closing structure; and

[0025] Figs. 11 through 13 are views sequentially illustrating a movement procedure of a hook in the first door opening/closing structure.

### **DETAILED DESCRIPTION OF THE INVENTION**

[0026] Reference will now be made in detail to the preferred embodiments of the present invention, examples of which are illustrated in the accompanying drawings.

[0027] Fig. 1 is a perspective view of an electric oven to which the present invention is applied.

[0028] Referring to Fig. 1, an electric oven 1 according to the present invention includes: a cavity 3 having a heating element in its inside; a door 30 formed on one side of the cavity 3, for selectively being opened/closed so that food may be put in and out; a pair of latches 20 provided to an inner side of the door 30; and a receiving hole 6 provided to one side of a housing 5, for fixing the door 30 by receiving the latch 20. Further, a hooked portion such as ring 65 formed on about a central portion of the inner side of the door 30, and a hook 60 for selectively

being engaged with the hooked portion 65 in its inside and catching the hooked portion 65 so that the door 30 may not be opened when the door 30 is in a closed state.

[0029] Operation of the door opening/closing apparatus according to the present invention will be briefly described below. If a user closes the cavity 3 by taking the door 30 with one hand, the latch 20 is inserted into the receiving hole 6 and fixed by a predetermined second door opening/closing structure formed in the receiving hole 6. When the latch 20 is inserted into the receiving hole 6, the second door opening/closing structure detects insertion of the latch 20, thereby checking detection of the door 30. Further, the second door opening/closing structure performs a function of determining that the door is not closed when an alien material, not the latch 20, is inserted.

[0030] Further, to prevent unexpected dangerous circumstances such as a case in which the cavity is heated to a high temperature during operation of the electric oven and a user does not recognize such a high temperature and opens the cavity, a first door opening/closing structure making the hooked portion 65 caught on the hook 60 is provided. The first door opening/closing structure may be formed at an electric equipment unit in an upper portion of the cavity.

[0031] The first door opening/closing structure can be understood as a door locking apparatus and the second door opening/closing structure can be understood as a door interlocking apparatus. More specifically, the door interlocking apparatus is a predetermined structure for preventing the door from being detected as being closed using a door switch formed in an inside of the receiving hole 6 when a user inadvertently inserts a rod into the receiving hole 6. If the door is detected as being closed due to the inadvertently inserted rod and the electric oven starts to operate, a dangerous circumstance such as a fire in a room may be caused. Therefore, the door should be exactly detected as being closed only when the latch 20 is inserted reasonably.

[0032] In the meantime, the electric oven 1 of the present invention further includes: an operation unit 4 for operating the electric oven 1 according to a user's intention; an exhaust port 2 for exhausting water vapor generated while food is being cooked in an inside of the cavity 3; a convection fan 7 formed in an inside of the cavity 3, for circulating an air in the inside of the cavity 3 convectively. Further, if necessary, a hot plate (not shown) is provided to an upper surface of the electric oven so that a cookware such as a pot may be placed and food is cooked.

[0033] Figs. 2 through 8 are views illustrating a door interlocking apparatus according the present invention. Referring to Figs. 2 through 8, the door interlocking apparatus will be described in detail.

[0034] Fig. 2 is a cross-sectional view, taken along line I-I' of Fig. 1, and illustrating a construction of a latch. Referring to Fig. 2, the latch 20 is formed in an inside of the door 30 and the latch 20 can stably operate at a set

position. For maintaining stable operation of the latch 20, there are provided a latch pivot 21 functioning as a pivot of the latch 20 at a central position of a latch operation, and a latch spring 22 connecting a rear end of the latch 20 with a latch fixing part 23 to operate the latch 20 elastically. The latch 20 slightly rotates in a clockwise direction about the latch pivot 21 during a closing operation of the door 30 and once the latch 20 is inserted, the latch 20 rotates again in a counterclockwise direction. At this point, since force by which the latch 20 would rotate counterclockwise is constantly applied by the latch spring 22, a position of the latch 20 may be stably maintained. Further, a hook-shaped latch head 24 is formed on a front end of the latch 20, thus an insertion operation of the latch 20 can be stably performed and after the latch 20 is inserted, a hooking operation is performed and a position of the door 30 can be fixed.

**[0035]** Fig. 3 is a cross-sectional view, taken along line II-II' of Fig. 1 and illustrating a second door opening/closing structure. Referring to Fig. 3, a latch board 40 is formed in an inside of the receiving hole 6. The latch board 40 performs a function of detecting whether the latch 20 is inserted or not, together with a function of fixing a position of the latch 20. Further, if an alien material such as a pin, not the latch 20, is inserted, the latch board 40 may perform a function of detecting that the door is not closed.

**[0036]** The latch board 40 includes: a plurality of operation parts 45, 48, and 50 to be moved by the latch head 24 when the latch 20 is inserted into an inside of the receiving hole 6; micro-switches 41 and 42 for detecting the insertion of the latch 20 by receiving movements of the operation parts; and a latch hooking part 53 for guiding the insertion operation of the latch 20 and fixing a position of the inserted latch 20.

**[0037]** More specifically, the operation parts includes: a first operation part 45 to be touched first when the latch 20 is inserted; a third operation part 50 pressed in cooperation with the first operation part 45; and a second operation part 48 sequentially moving after the first operation part 45 is moved. Further, the first operation part 45, which is a plate-shaped member, rotates on a first pivot 46, and a pressing part 51 is extended from a predetermined position of the first operation part 45. The second operation part 48 has one end touched to the latch head 24 and other end touched to a second switch button 44 of the second micro-switch 42 so as to be rotated about the second pivot 49. In the third operation part 50, one end is fixed to the first micro-switch 41 and other end is pressed by the pressing part 51 so as to make a first switch button 43 switched on. The operation parts are formed into a plate shapes, whereby cooperative operation of the operation parts can be swiftly performed.

**[0038]** Further, a spring 47 is interposed between other end of the first operation part 45 and the latch board 40. A position of the first operation part 45 can be supported by the spring 47. For example, if the latch 20 is not inserted, the first operation part 45 is set to rotate counter-

clockwise on the first pivot 46. Of course, since the first operation part 45 is rotated counterclockwise, the pressing part 51 and the third operation part 50 are not touched each other, thus the first micro-switch 41 is in an off-state.

5 Further, under a state that the first operation part 45 is rotated counterclockwise, a terminal of the pressing part 51 pushes the second operation part 48 so that the second operation part 48 may be rotated counterclockwise. Thus, the second micro-switch 42 is also in an off-state.

10 **[0039]** If the latch 20 is inserted under such a state, the first operation part 45 and the second operation part 48 are sequentially touched to the latch head 24. The first operation part 45 continuously moves the third operation part 50. After that; the first micro-switch 41 is switched on by the third operation part 50, and the second micro-switch 42 is switched on by the second operation part 48. The micro-switches 41 and 42 are sequentially switched on, whereby the door 30 can be detected as being normally closed. Of course, switch-on operations of the micro-switches 41 and 42 are delivered to a controller of the electric oven, and an interval of the delivered continuous detection signal is judged, so that the door 30 is detected as being closed. If an alien material such as a spoon is inserted into the receiving hole 6, the operation parts 45 and 48 are not operated continuously. In that case, it may be judged that the door 30 is not closed because other material, not the latch 20 is inserted.

20 **[0040]** Figs. 4 through 6 are views sequentially illustrating an insertion process of the latch. Fig. 4 illustrates a state just before the latch is inserted, Fig. 5 illustrates a state that the latch is inserted to some extent and the first micro-switch 41 is switched on, and Fig. 6 illustrates a state that the latch is inserted completely and the second micro-switch 42 is also switched on as well as the first micro-switch 41.

30 **[0041]** Referring to Fig. 4, before the latch 20 is inserted, the first operation part 45 is rotated counterclockwise by the spring 47 and the pressing part 51 only touches to the third operation part 50, thereby not applying any force on the third operation part 50. At this point, the first and the second micro-switches 41 and 42 are all in a switch-off state. Referring to Fig. 5, the latch head 24 is touched to the first operation part 45, and the first operation part 45 is rotated clockwise on the first pivot 46. If the first operation part 45 is rotated, the pressing part 51 is rotated clockwise on the whole, pressing the third operation part 50. Then, the third operation part 50 presses the first switch button 43 so that the first micro-switch 41 may be switched on. Referring to Fig. 6, if inserted even further, the latch head 24 pushes the second operation part 48 to rotate the same clockwise. At this point, a terminal of the second operation part 48 presses the second switch button 44 so that the first micro-switch 42 may be switched on. Further, if the latch 20 is inserted completely, the latch head 24 is hooked on the latch hooking part 53, so that the latch 20 can be detached only when predetermined external force is applied. Thus, a position of

the closed door 30 can be stably fixed.

**[0042]** In the meantime, the micro-switches 41 and 42 are sequentially switched on during a series of operations of the operation parts 45, 48, and 50. According to an experiment, a time difference of about 4ms is generated. The continuous detection signal of the micro-switch is delivered to the controller of the electric oven so that whether the door is normally closed can be detected. Of course, since a continuous delivery of the detection signal may have an error to some extent, a time difference of  $4 \pm 1$  ms may be judged as closing of the door.

**[0043]** The sequential operation of the micro-switch by an interlocking apparatus of the second door opening/closing structure is intended to prevent a circuit for a safety apparatus provided to an inside of the micro-switch from being connected simultaneously. If the circuit for the safety apparatus operating in cooperation with the micro-switch is connected simultaneously to operate, a power switch is falsely operated, so that an arcing region, in which the electric oven automatically operates without an instruction of a user, may be generated.

**[0044]** In the meantime, in an opening operation of the door, a hooking position of the latch hooking part 53 and the latch head 24 is released, and the latch head 24 is rotated clockwise by a predetermined amount in order to be ejected through the receiving hole 6. At this point, the first operation part 45 is rotated counterclockwise by force of the spring 47, the second operation part 48 is also rotated counterclockwise by a pressing operation of the pressing part 51, and the third operation part 50 is restored to its original position by elasticity of its own.

**[0045]** Figs. 7 and 8 illustrate an operation sequence of the second door opening/closing structure when a pin, not the latch is inserted into the second door opening/closing structure. Referring to Figs. 7 and 8, if an alien material such as a pin P is mistakenly inserted into the receiving hole 6 by a user, the first micro-switch 41 may be normally switched on by the first operation part 45. However, it is easily expected that the pin P requires a little more time to operate the second operation part 48 than the latch 20 because it may take a more time until the first operation part 45 is pushed to its end by the pin P to push the second operation part 48, and such a time may be at least more than 4ms. Further, the second operation part 48 might not be pushed by the pin P, depending on cases.

**[0046]** Since closing of the door can be exactly detected by the above-described second door opening/closing structure, malfunction associated with the door is reduced.

**[0047]** Figs. 9 through 13 illustrate the first door opening/closing structure as a door locking apparatus. The first door opening/closing structure is intended to prevent the door from being opened even by an external force from a user while a thermal decomposition cleaning is performed in the cavity, so that user's safety can be enhanced even more.

**[0048]** Fig. 9 is a cross-sectional view taken along line

III-III' of Fig. 1, illustrating the first door opening/closing structure. Referring to Fig. 9, the first door opening/closing structure includes: a hook 60 selectively hooked on the hooked portion 65; and a hook operation unit 80 for generating external force by which the hook 60 is operated. The hook operation unit 80 includes: a motor 70 for generating power; a cam operation shaft 71 extended to a lower side of the motor 70 so that the hook 60 may be operated in cooperation with the motor 70; a cam 72 on an eccentric position of which the cam operation shaft 71 is formed; and a cam guide 73 into which the cam 72 is inserted so that a predetermined hook operation is performed. Further, a guide slot 61 having an elongated shape in an up and down direction is formed on each side of the cam guide 73, and a guide member 82 fixed to the hook operation unit 80 is provided in the guide slot 61 to guide a movement of the hook 60, are provided. Further, a micro-switch 81 performing on/off operation according to a rotational angle of the cam 72 is provided to control closing/releasing of the door.

**[0049]** In the meantime, the guide slot 61 is formed obliquely at a predetermined angle of  $\alpha$  so that the hook 60 may move in a direction inclined of a predetermined angle.

**[0050]** Fig. 10 is a side view of the first door opening/closing structure. Referring to Fig. 10, the motor 70, the cam operation shaft 71 extending downwardly from the motor 70, the cam 72 formed at the end of the cam operation shaft 71, and the micro-switch 81 are illustrated.

**[0051]** Referring to the above-described first door opening/closing structure, an operation of the first door opening/closing structure will be briefly described. When the motor 70 is rotated, the cam operation shaft 71 is rotated. The cam operation shaft 71 rotates the cam 72 on the whole and the cam 72 pushes the cam guide 73 so that the hook 60 may be moved wholly in up and down directions. Further, when the hook 60 is moved in the up and down directions, the hook 60 is made to be moved in a predetermined direction only by interaction between the guide slot 61 and the guide member 82, whereby the hook 60 can be exactly hooked on the hooked portion 65. Further, it is also possible to make the rotation of the motor 70 stopped when the rotation of the cam operation shaft 71 is detected by the micro-switch 81, and the door may be judged to have been closed completely.

**[0052]** Figs. 11 through 13 sequentially illustrate a movement process of the hook. Referring to Figs. 11 through 13, the hooked portion 65, the cam 72, the cam operation shaft 71, and the guide member 82 are fixed and only the hook 60 is moved.

**[0053]** Referring to Fig. 11, the hook 60 is hooked on the hooked portion 65 so that the door 30 is closed. Under such a state, even if a user intends to open the door, the door would not be opened. The inside of the cavity may be in a state in which food's remnant is being thermally decomposed by high temperature. The cam operation shaft 71 is rotated, such that the cam 72 is rotated about the cam operation shaft 71. The cam operation shaft 71

forces the hook 60 to move on the whole by an operation of pushing/pulling the cam guide 73. The hook 60 is moved in a predetermined direction by an interaction between the guide member 82 and the guide slot 61. Particularly, since the guide slot 61 is obliquely formed from the upper left to the lower right, the hook 60 is also moved in the direction inclined toward the upper left in order to be completely detached from the hooked portion 65.

**[0054]** Fig. 12 illustrates that the hook 60 has moved half of the whole movement distance with the cam rotated about 90°, and Fig. 13 illustrates that the hook 60 has moved completely the whole movement distance with the cam rotated about 180°.

**[0055]** Further, although Figs. 11 through 13 illustrate that the hook is moved to a door-opening direction, it is easily expected that the hook will be moved in a door-closing direction by movement of the cam 72 in an opposite direction.

**[0056]** In the meantime, although the present embodiment explains that the hooked portion is formed in the door and the hook is formed in the main machine of the oven, the hook and the hooked portion may be also formed in the door and the main machine, respectively, of course. The above configuration may be applied in the same way to the second door opening/closing structure.

**[0057]** In the door opening/closing apparatus of the electric oven according to the present invention, the first door opening/closing structure, a door locking structure, prevents the locked door from opening, and simultaneously the second door opening/closing structure, a door interlocking structure, indicates the opening/closing of the door exactly. Thanks to such a configuration, the first door opening/closing structure is operated only when the door is detected as being completely closed by the second door opening/closing structure. However, either the first or the second opening/closing structure may be selectively applied, depending on a specific application type of the electric oven. That is, by mounting the first door opening/closing structure, it is possible to safely use the electric oven when the door is closed. By mounting the second door opening/closing structure, it is also possible to prevent the electric oven from being operated under an unsafe state resulting from an inadvertent behavior of a user. Of course, the whole spirit of the present invention can be fully realized in case both the first and the second opening/closing structures are used simultaneously.

**[0058]** Further, although the first and the second opening/closing structures perform their opening/closing operation using the latch and the hooked portion separately formed in the door, the first and the second opening/closing structures may also operate in cooperation with each other using a latch structure integrally formed in the door.

**[0059]** According to the door opening/closing apparatus of the present invention, an accident that may occur due to malfunction of the electric oven can be prevented in advance, and thereby a safety in using the electric oven can be enhanced even more.

**[0060]** Particularly, since opening of the door is prevented in case the inside of the cavity is maintained at high temperature due to an inadvertent use, safety in using the electric oven is enhanced even more. Further, an erroneous detecting that the door is closed due to insertion of an alien material can be prevented, whereby a danger of a fire in a room due to a high temperature generated from the electric oven can be removed.

**[0061]** Still further, the structure of the door opening/closing apparatus of the electric oven is simplified, so that manufacturing cost can be reduced and the apparatus can be conveniently applied to products.

**[0062]** It will be apparent to those skilled in the art that various modifications and variations can be made in the present invention. Thus, it is intended that the present invention covers the modifications and variations of this invention provided they come within the scope of the appended claims and their equivalents.

## Claims

1. An electric oven (1) including a door opening/closing apparatus, said electric oven (1) having a cavity (3) where a high temperature condition is formed, a door (30) for selectively opening/closing the cavity (3), and a door opening/closing structure for exactly opening/closing the door (30), the door opening/closing apparatus comprising:

a hooked portion (65) formed on the door (30);  
 a hook (60) arranged to be selectively caught on the hooked portion (65);  
 a cam guide (73); and  
 a cam (72) inserted into the cam guide (73), for moving the cam guide (73), said cam (72) being adapted to be rotated by external force;  
**characterized in that**  
 said hooked portion (65) is formed on an inner side of the door (30); and  
 said cam guide (73) is formed on a body of the hook (60).

2. The electric oven (1) according to claim 1, wherein the body of the hook (60) comprises a guide slot (61) for guiding a movement of the hook (60), and a guide member (82) inserted into the guide slot (61).
3. The electric oven (1) according to claim 2, wherein the guide slot (61) is obliquely formed.
4. The electric oven (1) according to any one of claims 1 through 3, further comprising:

a latch (20) formed on an inner side of the door (30);

a first (45) and a second operation part (48) arranged to be sequentially operated by the latch (20); and  
 a first (41) and a second micro-switch (42) arranged to be sequentially switched on by the first and second operation parts (45,48).

5. The electric oven (1) according to claim 4, further comprising a spring (47) for guiding a position of the first operation part (45) by connecting the first operation part (45) with a latch board (40). 10
6. The electric oven (1) according to claim 4 or 5, further comprising a third operation part (50) for switching on the first micro-switch (41) by acting in cooperation with the first operation part (45). 15
7. The electric oven (1) according to any one of claims 4 through 6, wherein the first and second operation parts (45,48) rotate on a predetermined pivot (47). 20
8. The electric oven (1) according to any one of claims 4 through 7, further comprising a latch hooking part (53) for having the latch (20) smoothly inserted. 25
9. The electric oven (1) according to any one of claims 4 through 8, wherein the first and second operation parts (45,48) are arranged to be selectively touched.
10. The electric oven (1) according to any one of claims 1 through 9, wherein the cam (72) is inserted into the cam guide (73) such that the rotation of the cam (72) directly moves the hook (60) into and out of engagement with/from the hooked portion (65). 30

#### Patentansprüche

1. Elektrischer Ofen (1) mit einer Türöffnungs-/Schließvorrichtung, wobei der elektrische Ofen (1) aufweist:  
 einen Garraum (3), in dem ein Hochtemperaturzustand geschaffen wird,  
 eine Tür (30) zum selektiven Öffnen/Schließen des Garraums (3), und  
 eine Türöffnungs-/Schließstruktur zum exakten Öffnen/Schließen der Tür (30),  
 wobei die Türöffnungs-/Schließvorrichtung umfasst:  
 einen Hakenabschnitt (65), der an der Tür (30) ausgebildet ist,  
 einen Haken (60), der so angeordnet ist, dass er selektiv am Hakenabschnitt (65) eingreift,  
 eine Nockenführung (73), und  
 einen Nocken (72), der in die Nockenführung (73) eingesetzt ist, zum Bewegen der Nockenführung (73), wobei der Nocken (72) durch eine externe Kraft gedreht werden kann,  
**dadurch gekennzeichnet, dass**  
 der Hakenabschnitt (65) an einer Innenseite der Tür (30) ausgebildet ist, und  
 die Nockenführung (73) an einem Körper des Hakens (60) ausgebildet ist.

2. Elektrischer Ofen (1) nach Anspruch 1, wobei der Körper des Hakens (60) einen Führungsschlitz (61) zum Führen einer Bewegung des Hakens (60) aufweist, sowie ein in den Führungsschlitz (61) eingesetztes Führungselement (82).
3. Elektrischer Ofen (1) nach Anspruch 2, wobei der Führungsschlitz (61) schräg ausgebildet ist.
4. Elektrischer Ofen (1) nach einem der Ansprüche 1 bis 3, ferner mit:  
 einer an einer Innenseite der Tür (30) ausgebildeten Verriegelung (20),  
 einem ersten (45) und einem zweiten Betätigungsteil (48), die so angeordnet sind, dass sie nacheinander von der Verriegelung (20) betätigt werden, und  
 einem ersten (41) und einem zweiten Mikroschalter (42), die so angeordnet sind, dass sie nacheinander durch die ersten und zweiten Betätigungsteile (45,48) eingeschaltet werden.
5. Elektrischer Ofen (1) nach Anspruch 4, ferner mit einer Feder (47) zum Führen einer Position des ersten Betätigungsteils (45) durch Verbinden des ersten Betätigungsteils (45) mit einer Verriegelungsplatte (40).
6. Elektrischer Ofen (1) nach Anspruch 4 oder 5, ferner mit einem dritten Betätigungsteil (50) zum Einschalten des ersten Mikroschalters (41) durch Zusammenwirken mit dem ersten Betätigungsteil (45).
7. Elektrischer Ofen (1) nach einem der Ansprüche 4 bis 6, wobei die ersten und zweiten Betätigungsteile (45,48) sich an einem vorbestimmten Drehpunkt (47) drehen.
8. Elektrischer Ofen (1) nach einem der Ansprüche 4 bis 7, ferner mit einem Verriegelungs-Einhakteil (53) zum reibungslosen Einführen der Verriegelung (20).
9. Elektrischer Ofen (1) nach einem der Ansprüche 4 bis 8, wobei die ersten und zweiten Betätigungsteile (45,48) so angeordnet sind, dass sie selektiv berührt werden.

10. Elektrischer Ofen (1) nach einem der Ansprüche 1 bis 9, wobei der Nocken (72) in die Nockenführung (73) so eingeführt ist, dass die Drehung des Nockens (72) den Haken (60) direkt in und außer Eingriff mit/von dem Hakenabschnitt (65) bewegt.

### Revendications

1. Four électrique (1) comportant un appareil d'ouverture/de fermeture de porte, ledit four électrique (1) présentant une cavité (3) dans laquelle une condition de température élevée est formée, une porte (30) destinée à ouvrir/fermer sélectivement la cavité (3), et une structure d'ouverture/de fermeture de porte destinée à ouvrir/fermer exactement la porte (30), l'appareil d'ouverture/de fermeture de porte comprenant :

une partie crochetée (65) formée sur la porte (30) ;  
 un crochet (60) agencé pour être accroché sélectivement sur la partie crochetée (65) ;  
 un guide de came (73) ; et  
 une came (72) insérée à l'intérieur du guide de came (73), destinée à déplacer le guide de came (73), ladite came (72) étant adaptée pour être amenée en rotation par une force externe ;  
**caractérisé en ce que**  
 ladite partie crochetée (65) est formée sur un côté interne de la porte (30) ; et  
 ledit guide de came (73) est formé sur un corps du crochet (60).

2. Four électrique (1) selon la revendication 1, dans lequel le corps du crochet (60) comprend une fente de guidage (61) destinée à guider un déplacement du crochet (60), et un élément de guidage (82) inséré à l'intérieur de la fente de guidage (61).
3. Four électrique (1) selon la revendication 2, dans lequel la fente de guidage (61) est formée de manière oblique.
4. Four électrique (1) selon l'une quelconque des revendications 1 à 3, comprenant en outre :

un loquet (20) formé sur un côté interne de la porte (30) ;  
 une première partie d'opération (45) et une deuxième partie d'opération (48) agencées pour être actionnées de manière séquentielle par le loquet (20) ; et  
 un premier micro-interrupteur (41) et un second micro-interrupteur (42) agencés pour être fermés de manière séquentielle par les première

et deuxième parties d'opération (45, 48).

5. Four électrique (1) selon la revendication 4, comprenant en outre un ressort (47) destiné à guider une position de la première partie d'opération (45) en connectant la première partie d'opération (45) à une plaque de loquet (40).
6. Four électrique (1) selon la revendication 4 ou 5, comprenant en outre une troisième partie d'opération (50) destinée à fermer le premier micro-interrupteur (41) en agissant en coopération avec la première partie d'opération (45).
7. Four électrique (1) selon l'une quelconque des revendications 4 à 6, dans lequel les première et deuxième parties d'opération (45, 48) tournent sur un pivot (47) prédéterminé.
8. Four électrique (1) selon l'une quelconque des revendications 4 à 7, comprenant en outre une partie d'accouplement de loquet (53) destinée à ce que le loquet (20) soit doucement inséré.
9. Four électrique (1) selon l'une quelconque des revendications 4 à 8, dans lequel les première et deuxième parties d'opération (45, 48) sont agencées pour être touchées sélectivement.
10. Four électrique (1) selon l'une quelconque des revendications 1 à 9, dans lequel la came (72) est insérée à l'intérieur du guide de came (73) de telle sorte que la rotation de la came (72) déplace directement le crochet (60) en prise et hors de prise avec la partie crochetée (65).

FIG. 1

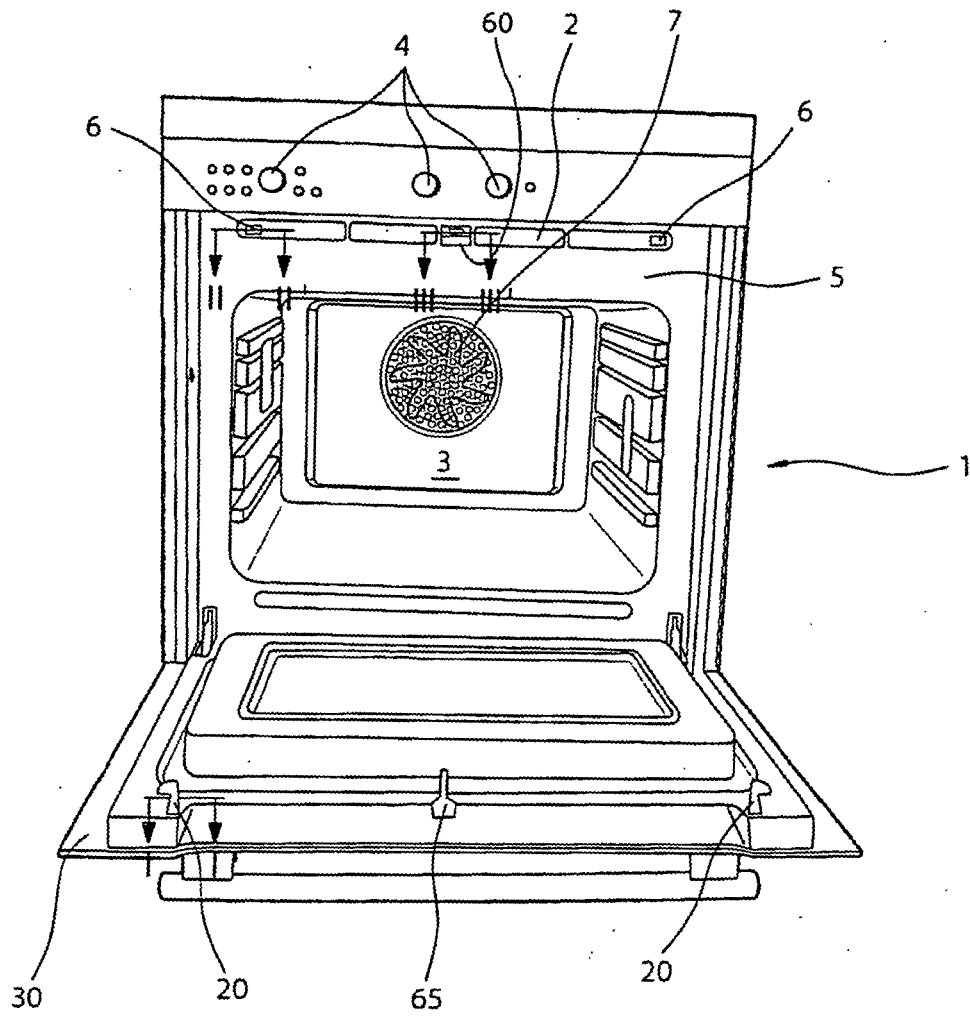

FIG. 2

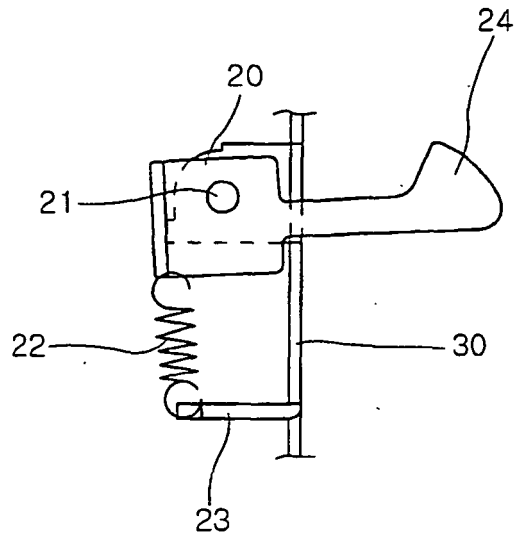

FIG. 3

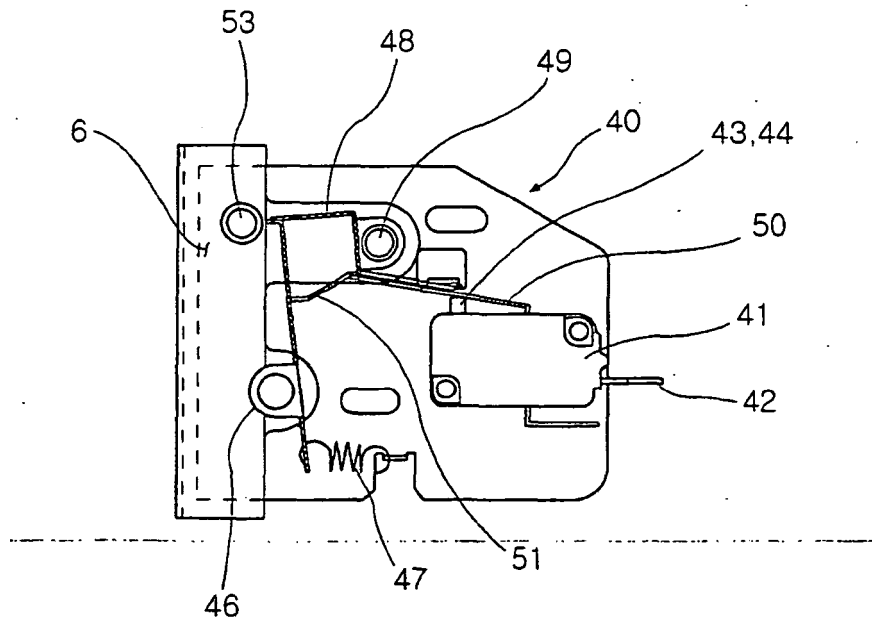

FIG. 4

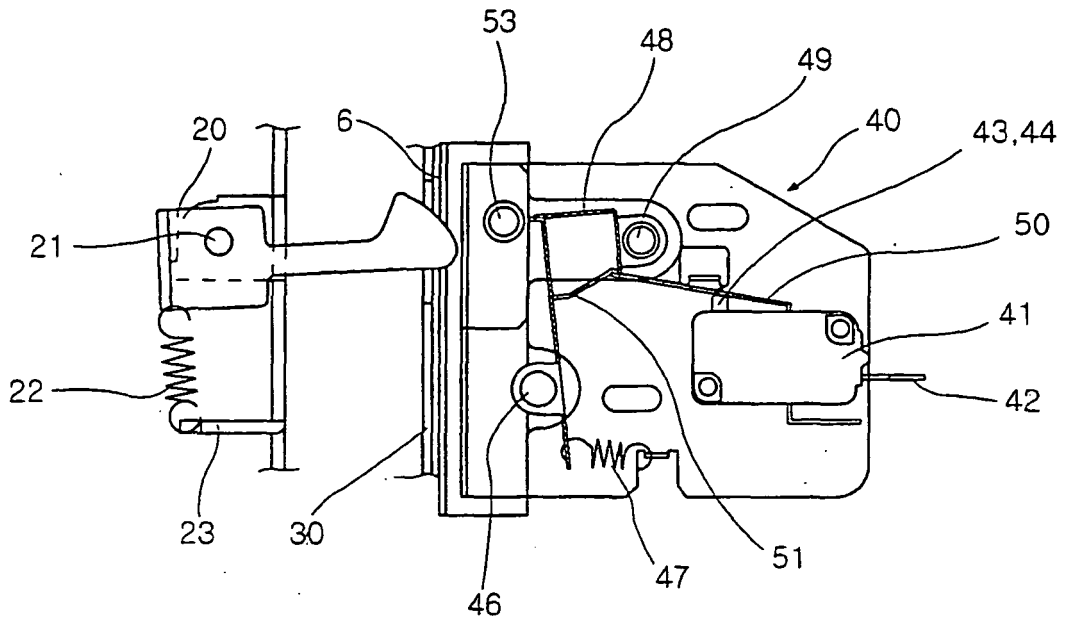

FIG. 5

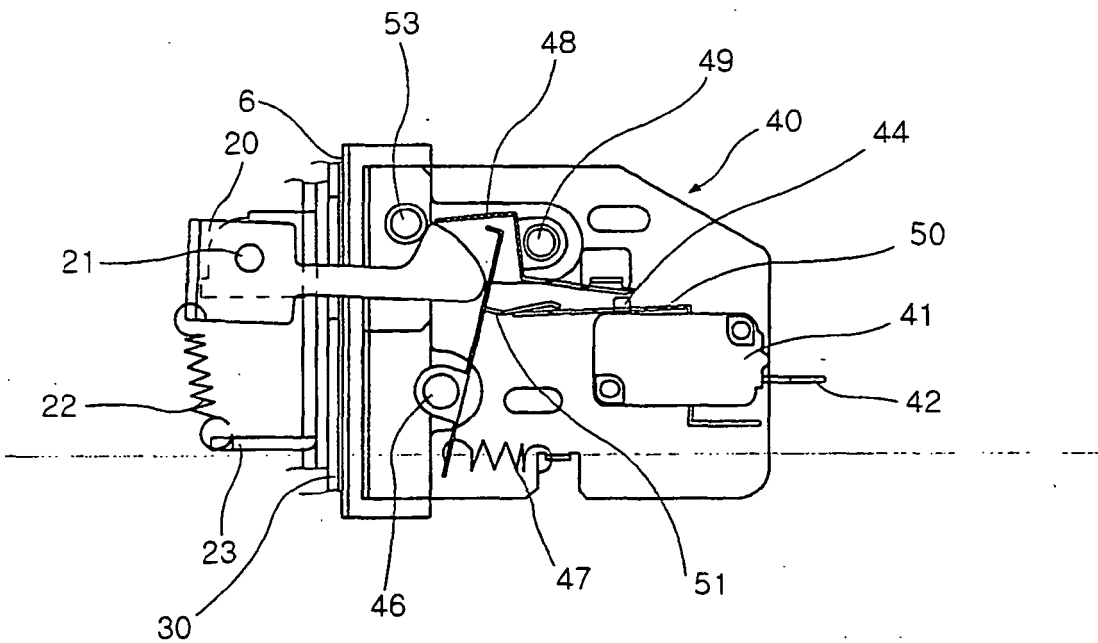

FIG. 6

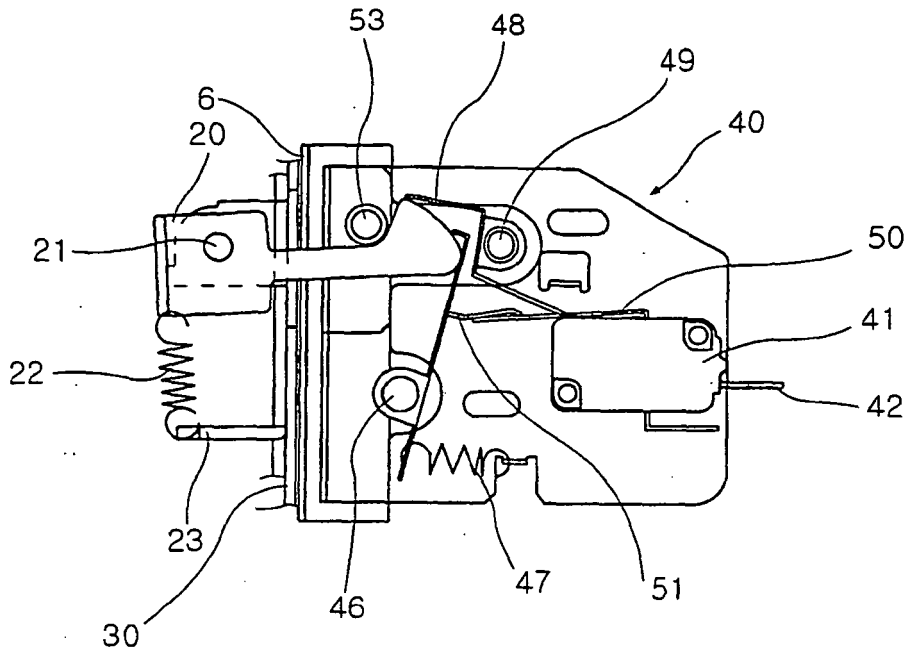

FIG. 7

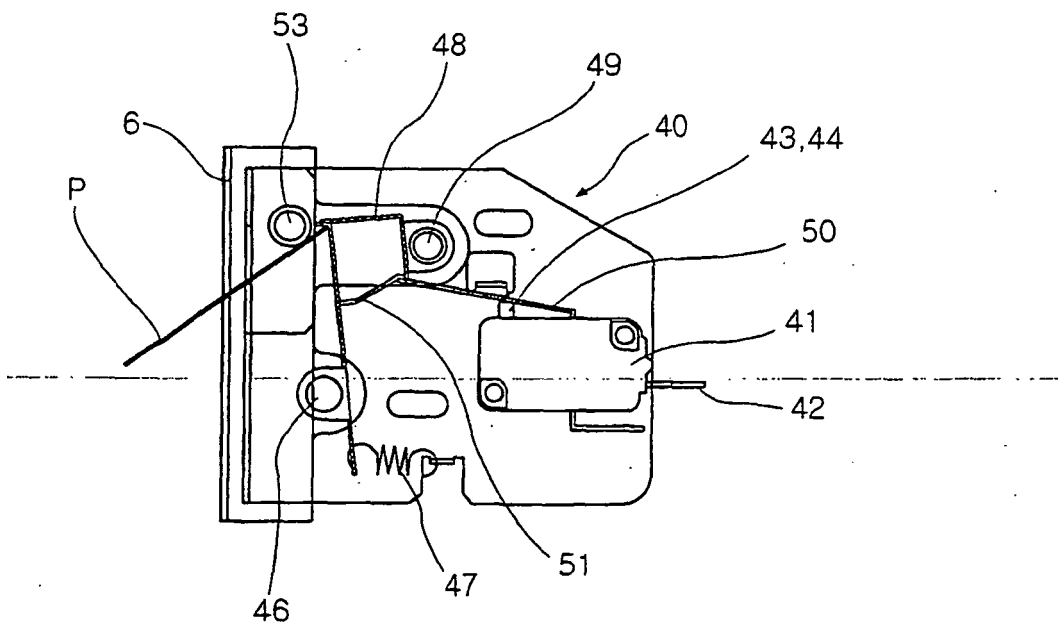

FIG. 8

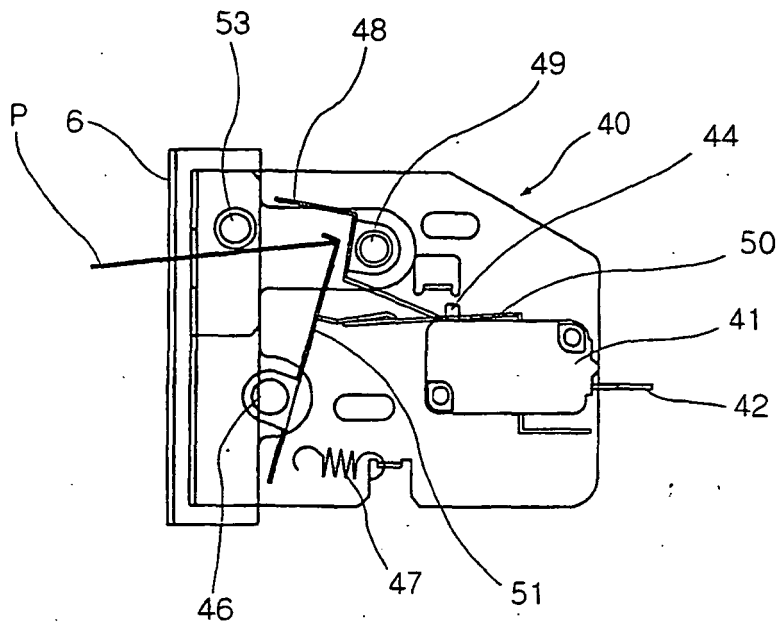

FIG. 9

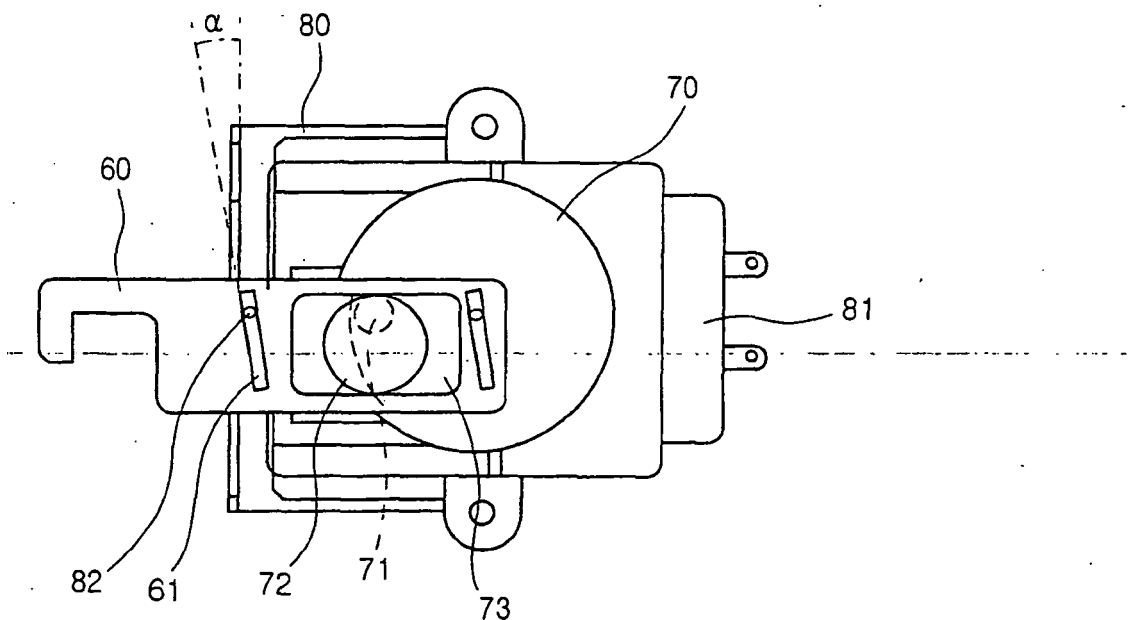

FIG. 10

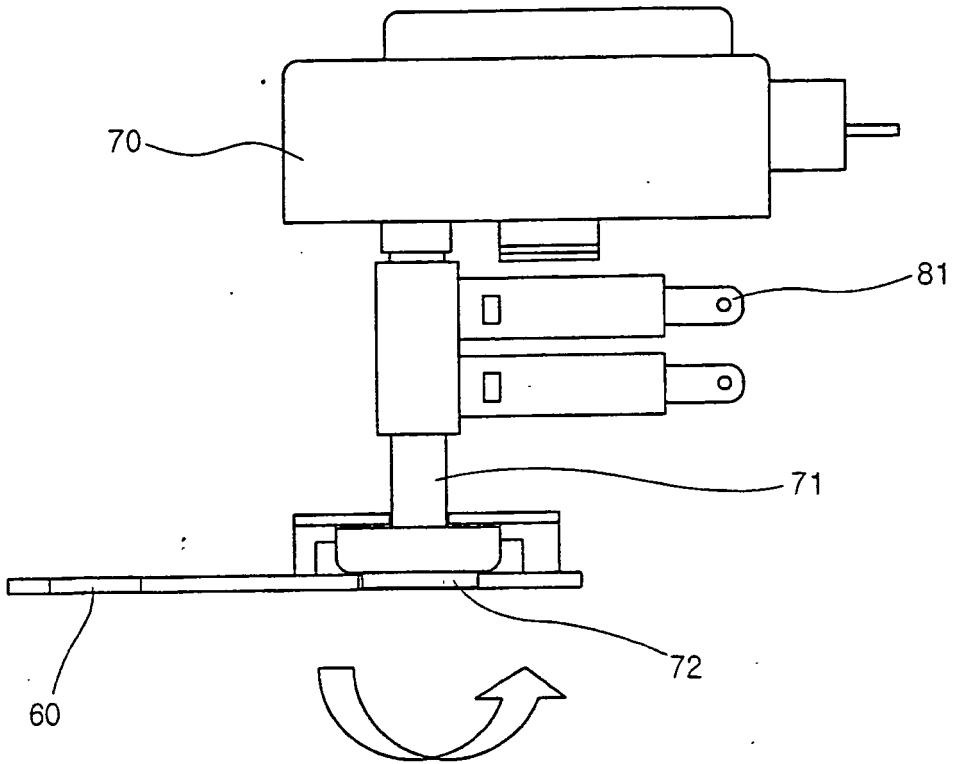

FIG. 11

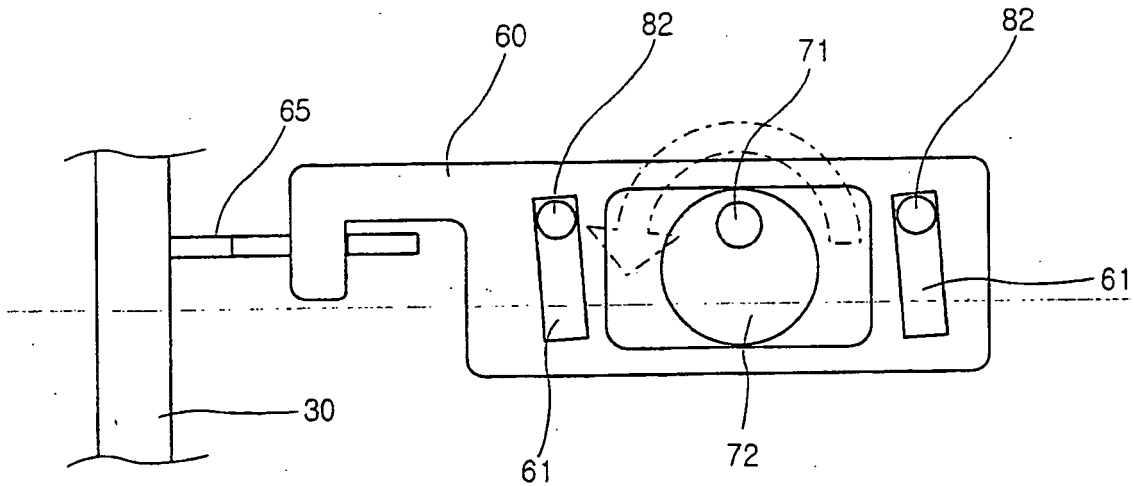

FIG. 12

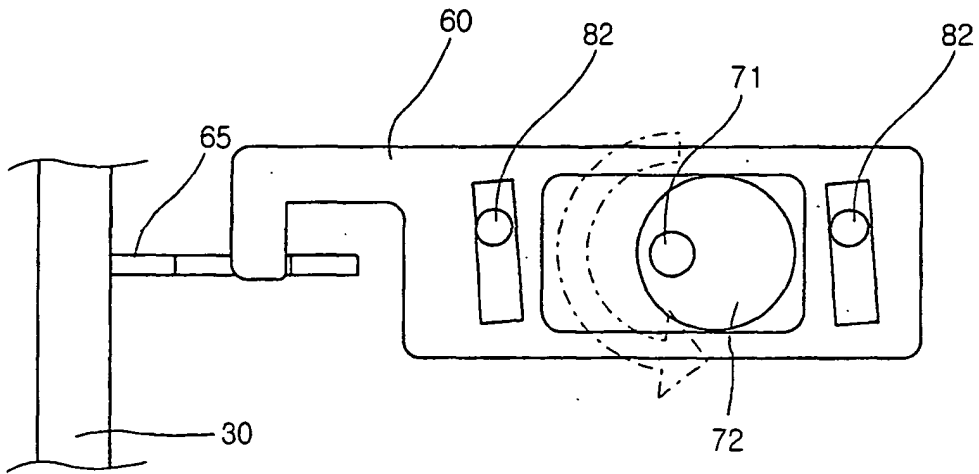
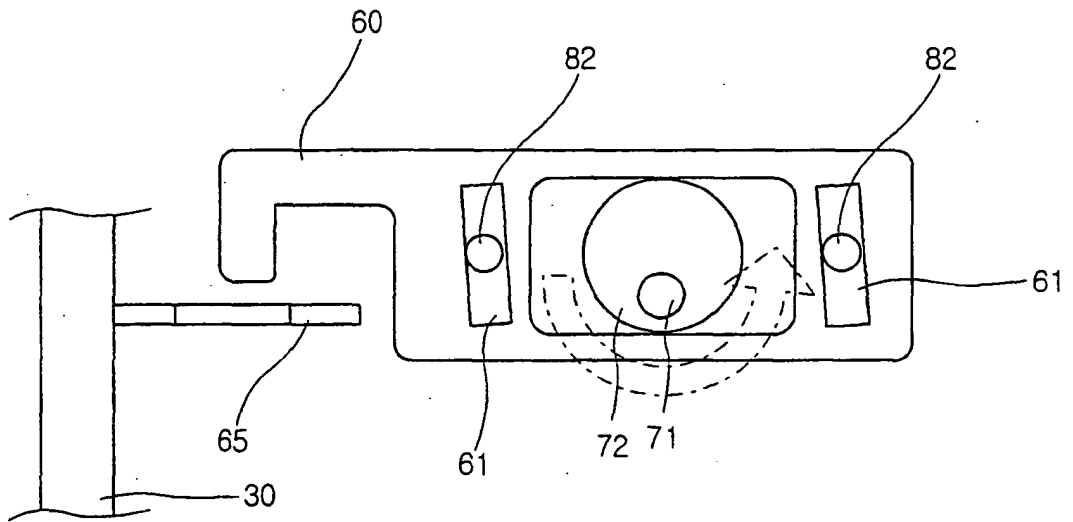

FIG. 13



**REFERENCES CITED IN THE DESCRIPTION**

*This list of references cited by the applicant is for the reader's convenience only. It does not form part of the European patent document. Even though great care has been taken in compiling the references, errors or omissions cannot be excluded and the EPO disclaims all liability in this regard.*

**Patent documents cited in the description**

- US 6315336 B [0004]
- EP 0617235 A [0006]