

ORGANISATION AFRICAINE DE LA PROPRIETE INTELLECTUELLE
(O.A.P.I.)



19

11 N°

11621

51 Inter. Cl. 7

E21B 17/01
E21B 43/017

BREVET D'INVENTION

21 Numéro de dépôt : 120000252

22 Date de dépôt : 11.03.1999

30 Priorité(s) : 14.03.1998 N° 60/078017
US

24 Délivré le : 17.10.2001

45 Publié le : 09 SEPT 2004

73 Titulaire(s) :

Société dite : SHELL INTERNATIONALE
RESEARCH MAATSCHAPPIJ B.V.
Carel Van Bylandtlaan 30
2596 HR THE HAGUE (NL)

72 Inventeur(s) :

1- DORGANT Paul Louis
4203 Bean Lodge Ctr.
HOUSTON, TX 77084 (US)
2- GALLAHER Dale Marion (US)
3- HANSEN Mark Christian (US)
4- LANGNER Carl Gottlieb (US)
5- COYNE Michael John (US)

74 Mandataire : CABINET CAZENAVE
B.P. 500
YAOUNDE - Cameroun

54 Titre : Supporting frame for risers.

57 Abrégé :

An offshore platform comprising a jacket structure supporting a platform deck having a wellbay, the jacket structure having a plurality of legs and a bracing assembly, at least one flowline extending from a remote well to a lower part of the jacket structure and from there in upward direction to the wellbay, wherein each flowline extends through a passage formed within the jacket structure and aligned with the wellbay, whereby the flowline is supported by the bracing assembly.

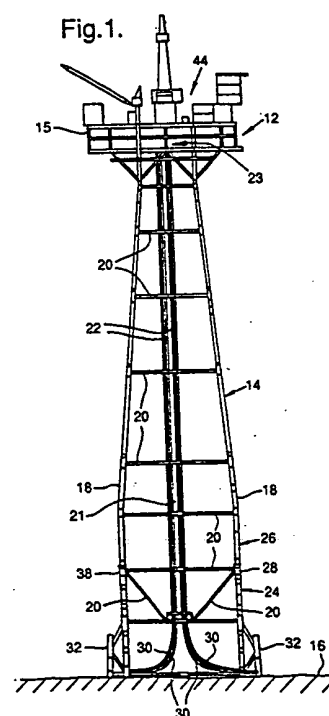

SUPPORTING FRAME FOR RISERS

Offshore development of hydrocarbon reserves requires substantial investments into both well development and infrastructure. Further, project economics increasingly demand the best utilization of equipment. In this development, the production facilities of a bottom founded platform may be useful for initial processing of hydrocarbons produced from wells not drilled and completed from the platform, e.g., from satellite subsea wells or from minimal platforms not providing such initial processing capabilities. Platforms with such processing capabilities then become central hubs upon which the minimal facilities depend for economic development of a region.

Providing this support to these remote wells requires that the wells be connected to the platform facilities by pipeline along the ocean floor and through vertical flowlines.

In the conventional practice, flowlines are run within or exteriorly aside the legs of the platform and require frequent support points connecting the flowlines to the vertical legs of the platform. This can require that the jacket be designed with additional legs to accommodate the flowlines, thus increasing the cost of materials (more steel) and increasing installation weight. This also requires a more complicated deck and facility design because produced fluids are conducted to the initial processing facilities from the exterior legs as well as from the central well bay. Such complications can substantially impact the economics of developing the region substantially more than the incremental cost of providing greater processing facilities.

Thus there is a need for an improved offshore platform for tying such remote production into a platforms processing facilities with minimal impact on the structure itself.

5 In accordance with the invention there is provided an offshore platform comprising a jacket structure supporting a platform deck having a wellbay, the jacket structure having a plurality of legs and a bracing assembly, at least one flowline extending from a remote well to a lower part of the jacket structure and from there in upward direction to the wellbay, wherein each flowline extends through a passage formed within the jacket structure and aligned with the wellbay, whereby the flowline is supported by the bracing assembly.

10 By positioning the flowline in the passage aligned with the wellbay and supporting the flowline at the bracing assembly it is achieved that additional steel for connecting each flowline to the legs is avoided, thus allowing a lower overall platform weight. Furthermore, it is avoided that the flowlines must be routed from the upper ends of the legs to the wellbay. It is to be understood that the wellbay is the area at the platform deck to which the flowlines from individual wells below the platform transport extend. Thus, in the platform of the present invention the flowlines from the remote wells and the flowlines from the wells below the platform extend within the jacket structure to a common wellbay.

15 The invention will be described hereinafter in more detail and by way of example with reference to the accompanying drawings, in which

20 Fig. 1 schematically shows a side view of a platform system according to the invention;

25 Fig. 2 schematically shows a perspective view of a jacket base applied in conjunction with the platform system of Fig. 1;

30

35

Fig. 3 is a top view of the jacket base of Fig. 2;

Fig. 4 schematically shows a longitudinal section of a conductor applied in conjunction with the platform system of Fig. 1;

5 Fig. 5A is a cross-section along line 5A-5A of Fig. 4;

Fig. 5B is a cross-section along line 5B-5B of Fig. 4; and

10 Fig. 5C is a cross-section of an alternative embodiment in accordance with the platform system according to the invention.

In Fig. 1 is shown an offshore platform 12 installed on the sea bed 16, the platform 12 including a platform deck 15 supported by a support structure 14 (also referred to as jacket) having four legs 18 and bracing 20 (simplified for the purpose of illustration). The jacket has a central passage 21 through which five conductor conduits 22 extend from near a lower end of the jacket 14 to a well bay 23 provided at the platform deck 15. The jacket is assembled from a lower portion in the form of platform base 24 and an upper portion 26, which portions are interconnected by docking pins (not shown) at connections 28. The two portions 24, 26 are fabricated as separate pieces. During installation the platform base 24 is first installed on the sea bed 16 whereafter the upper portion 26 is lowered through the water so as to be connected to the platform base 24.

As shown in more detail in Figs. 2 and 3, the platform base 24 is provided with five pull-tube bundles 30, each pull-tube bundle including a number of curved pull-tubes 31 extending from a substantially horizontal orientation near the lower perimeter of the platform base 24 to a substantially vertical orientation at the central passage 21. The pull-tubes 31 are fixedly connected to the bracing 20 and to the legs 18 or pile

sleeves 32 of the platform 12. This arrangement has the advantage that maximum protection is provided to the pull-tubes against the damaging effects of snagging anchors. Each pull-tube is at its lower end provided with an outwardly tapering guide funnel 34 for receiving a flowline as will be discussed hereinafter. The upper end parts of the individual pull-tubes 31 of each bundle 30 are held together by a conductor conduit sleeve 36 into which said upper end parts of the pull-tubes 31 converge, each pull-tube 31 being at its upper end provided with an outwardly tapering funnel 37 welded to the inner surface of the conductor conduit sleeve 36. The conductor conduit sleeves 36 are fixedly connected to the platform bracing 20 and are vertically aligned with the well bay 23.

Referring to Fig. 4, each conductor conduit sleeve 36 is connected to a corresponding one of the conductor conduits 22 in a vertically aligned relationship by means of a conductor connector 38. Lateral support is provided to the conductor conduits 22 at regular intervals by conductor guides (not shown) attached to the platform bracing 20. Thus the conductor guides have the same function as conductor guides conventionally applied to support large diameter, thick walled "drive pipes" or "conductors" through which drill strings, casing, tubing and production risers are run into wells below the platform. Each conductor conduit 22 is at its upper end provided with a circular plate 40 of larger diameter than the conductor, which plate 40 vertically suspends the conductor at the platform bracing 20. Furthermore, at least part of the required vertical support for each conductor conduit 22 is provided by the conductor conduit sleeve 36 to which the conductor conduit 22 is connected. The upper end part of each pull-tube 31 is vertically aligned with a corresponding guide-tube 42 extending from

within an upper part of the conductor conduit 22. conduit
via an opening in the plate 40, to a short distance above
the conductor conduit 22. The guide-tubes 42 are
substantially straight and have a diameter and a wall
5 thickness similar to the pull-tubes. The lower end of
each guide tube 42 is provided with a guide funnel 44
located only a short distance below the circular plate 40
and welded to the inner surface of the conductor
conduit 22.

10 During normal use of the offshore platform 12 each
pull-tube 31 is provided with a primary messenger wire
(not shown) extending through the pull-tube and having a
primary connector extending above the respective
funnel 37. Each primary messenger wire is at its lower
15 end connected to a pulling cable (not show) protruding
through the lower end of the pull-tube 31. The platform
base 24 with the pull-tube bundles 30 connected thereto
is then lowered to the seabed 16 and fixed by piles (not
shown) driven into the seabed through the pile
20 sleeves 32. In a next step the upper jacket portion 26 is
lowered to the platform base and connected thereto at
connections 28, during which step the conductor
conduits 22 are still absent from the upper jacket
portion 26. Once the upper portion 26 has been fixedly
25 connected to the platform base 24, each conductor
conduit 22 is lowered in vertical orientation through the
central passage 21 until the lower end of the conductor
conduit 22 is at a selected distance above the upper end
of the corresponding conductor conduit sleeve 32. A
30 secondary messenger wire (not shown) is then lowered
through each guide-tube 42, which secondary messenger
wire is at its lower end provided with a secondary
connector and which at its upper is connected to hoisting
equipment (not shown) arranged at the platform deck 15.
35 Next a remotely operated vehicle (ROV) is deployed to

connect the primary and secondary connectors of each pair of corresponding primary and secondary messenger wires to each other. The conductor conduit 22 is then further lowered so as to become connected to the corresponding conductor conduit sleeve 36 by means of the conductor connector 38. In this position the circular plate 40 of the conductor conduit 22 is suspended from the upper platform bracing 20, while part of the weight of the conductor conduit 22 is carried by the conductor conduit sleeve 36.

After the conductor conduits 22 have been installed in the manner described above, the hoisting equipment is operated to pull the messenger wires and the respective pulling cables attached thereto, through the respective pull-tubes and guide-tubes to the platform deck. Once the upper end of each pulling cable has been pulled to the platform deck, the lower end of the pulling cable is connected to a respective flowline extending along the seabed 16 to a satellite well (not shown). The hoisting equipment is then operated to pull each flowline through the corresponding pull-tube 31, conductor conduit 22 and guide-tube 42 to the platform deck 15 where the flowline is connected to suitable hydrocarbon fluid production equipment (not shown). Production of hydrocarbon fluid from each satellite well through the respective flowlines commences once all required flowline connections have been completed.

In Fig. 5A is shown cross-section 5A-5A of Fig. 4 after installation of the flowlines, indicating the arrangement of pull-tubes 31 and flowlines 46 inside one of the conductor conduit sleeves 36.

In Fig. 5B is shown cross-section 5B-5B of Fig. 4 after installation of the flowlines, indicating the arrangement of the flowlines 46 inside one of the

conductor conduit sleeves 36 at a position between the pull-tubes and the guide-tubes.

5 An alternative embodiment of the platform system according to the invention is shown in Fig. 5C where reference numeral 48 indicates a bundle of pull-tubes 47. In this embodiment the conductors described above are replaced by clamps 50 which hold together a number of pull-tubes 47 so as to form the pull-tube bundle 48. Each pull-tube 47 contains a flowline 52 which has been
10 installed in the same manner as described with reference to Figs. 1-4. Each pull-tube bundle 48 is connected to the jacket 14 at regular intervals in vertical direction. For example each bundle can be provided lateral support by conductor guides similar to those applied with
15 reference to Figs. 1-4.

Instead of the conductor conduit being connected to the conductor sleeve by the conductor connector described above, the conductor conduit can be provided at its lower end with a plate assembly of at least two vertical plates
20 which are suspended from the conductor conduit sleeve. For example two such plates can be applied to form a plate assembly having a cruciform cross-section, whereby the plates are suspended in corresponding vertical slots provided in the conductor conduit sleeve.

011621

N E W C L A I M S

1. An offshore platform comprising a jacket structure supporting a platform deck having a wellbay, the jacket structure having a plurality of legs and a bracing assembly, a plurality of flowlines extending from a
5 remote well to a lower part of the jacket structure and from there in upward direction to the wellbay, wherein each flowline extends through a passage formed within the jacket structure and aligned with the wellbay, each flowline being supported by the bracing assembly, wherein
10 said flowlines are kept together by a conductor conduit through which the flowlines of the flowline bundle extend, said conductor conduit being supported by the bracing assembly, characterised in that the conductor has an open lower end arranged at selected distance above the
15 sea floor, said flowlines extending through said open lower end.

2. The offshore platform of claim 1, wherein each flowline extends through a curved pull-tube having a substantially horizontal lower part extending near the seabed and a substantially vertical upper part extending
20 in said passage.

3. The offshore platform of claim 2, wherein each pull-tube extends into a lower end part of the conductor conduit.

25 4. The offshore platform of any one of claims 1-3, wherein each flowline extends through a guide-tube extending through an upper part of the conductor conduit.

30 5. The offshore platform of any one of claims 1-4, wherein said conductor conduit is internally provided with at least one support means to provide lateral support to each flowline in the conductor conduit.

6. The offshore platform of claim 5, wherein each said support means is formed by an inflated diaphragm.

7. The offshore platform of any one of claims 1-6, wherein each conductor conduit includes a lower part and an upper part connectable to the lower part, which lower part keeps said flowlines together to form said bundle and is fixedly connected to the jacket structure.

8. The offshore platform of claim 7, wherein said lower part and said upper part are interconnected by a conductor connector.

9. The offshore platform of claim 7, wherein said upper part is supported by a plate assembly including at least two vertical plates interposed between said upper part and said lower part, said plates being supported in corresponding vertical slots provided in the lower part.

10. The offshore platform of claim 9, wherein the plate assembly includes two said plates having a cruciform shaped cross-section.

11. The offshore platform substantially as described hereinbefore with reference to the accompanying drawings.

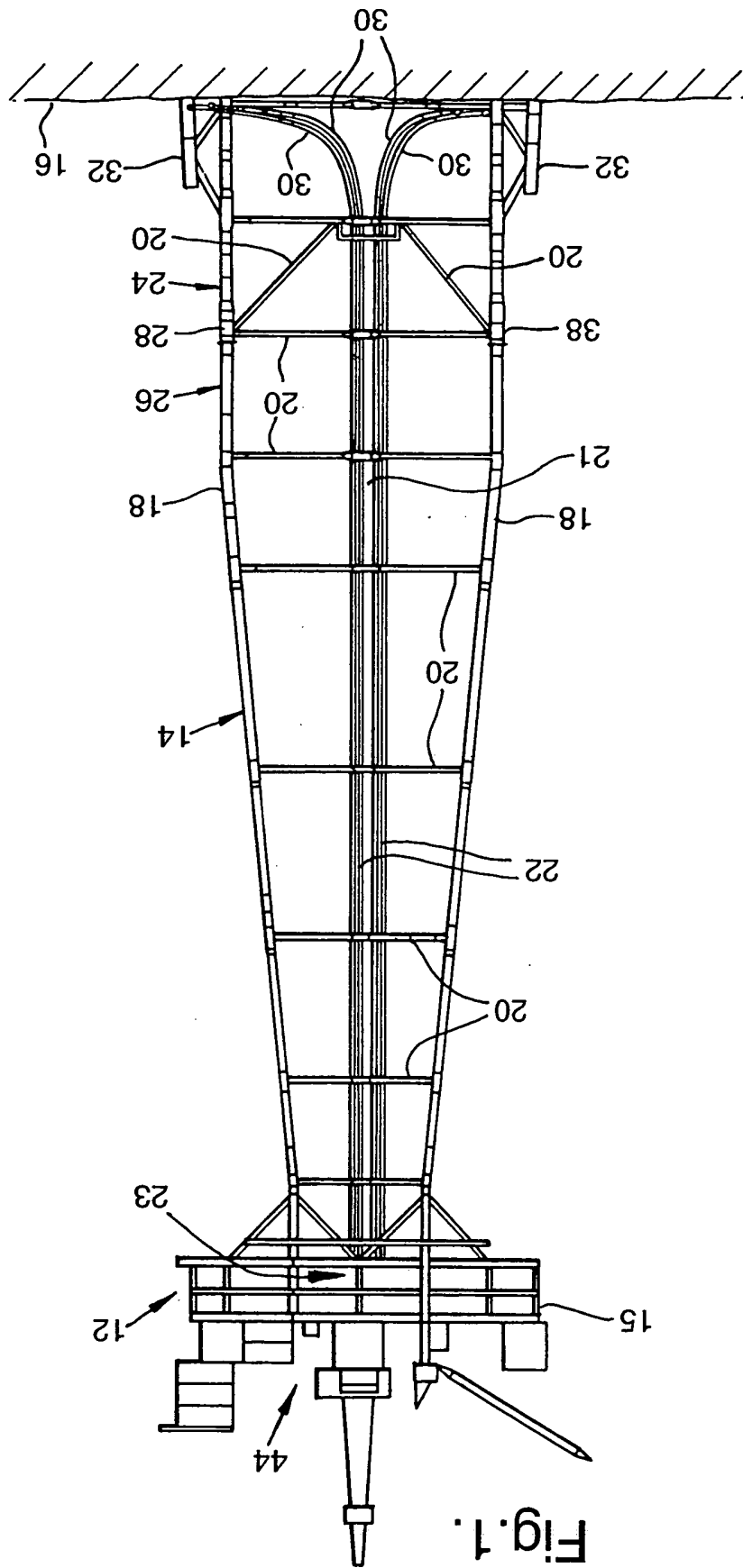

Fig. 1.

011621

Fig.2.

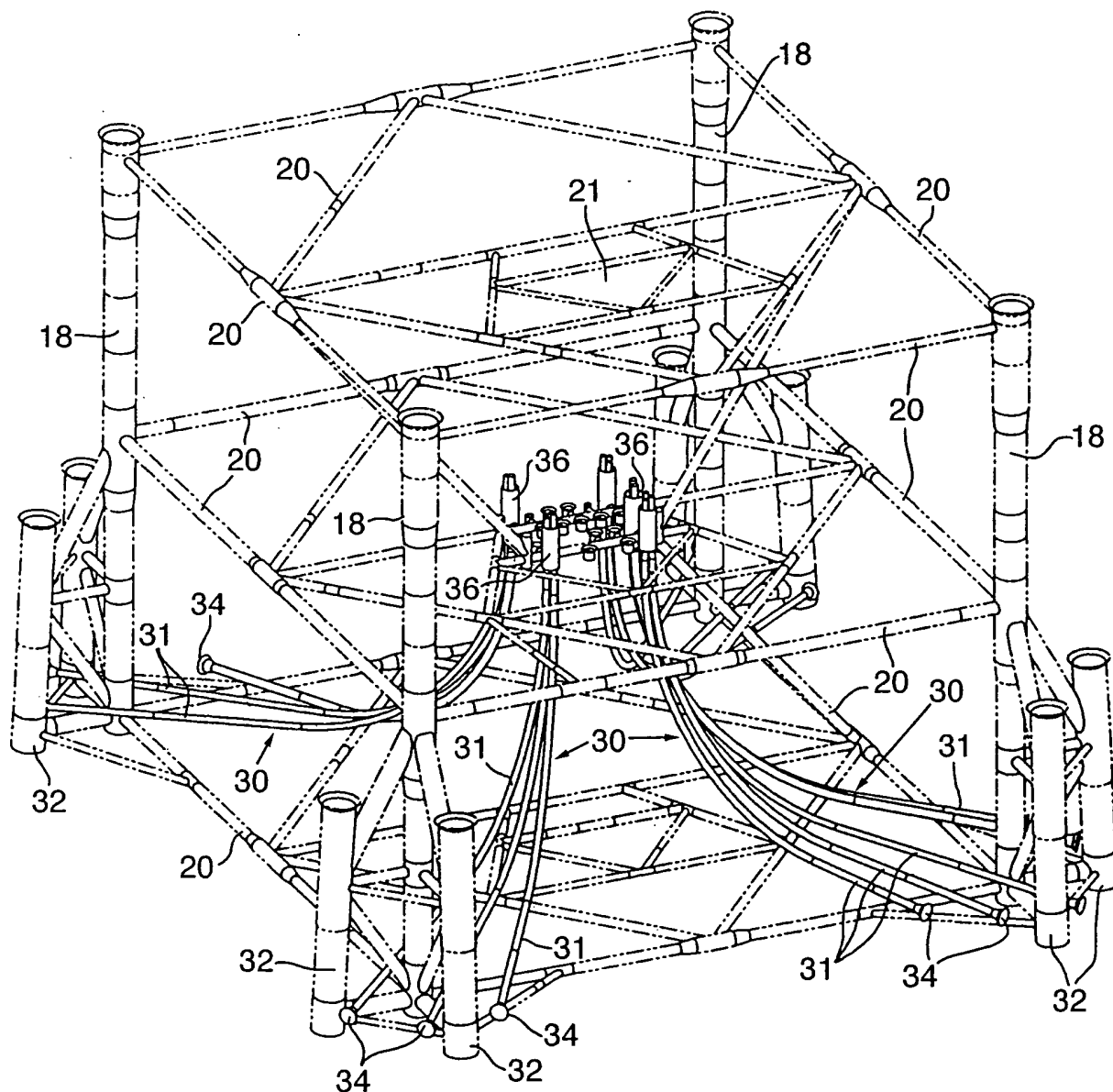

Fig.3.

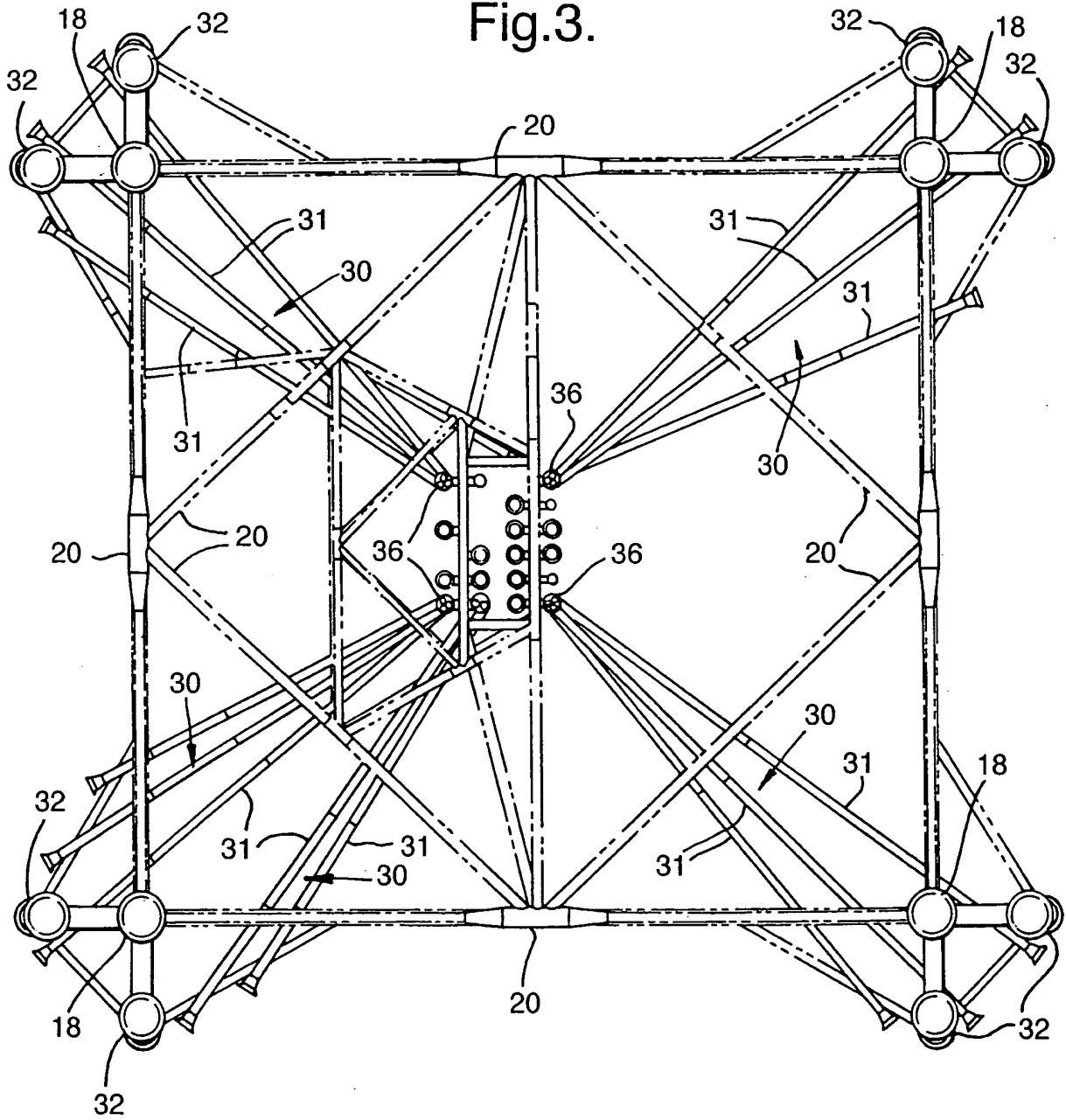

Fig.4.

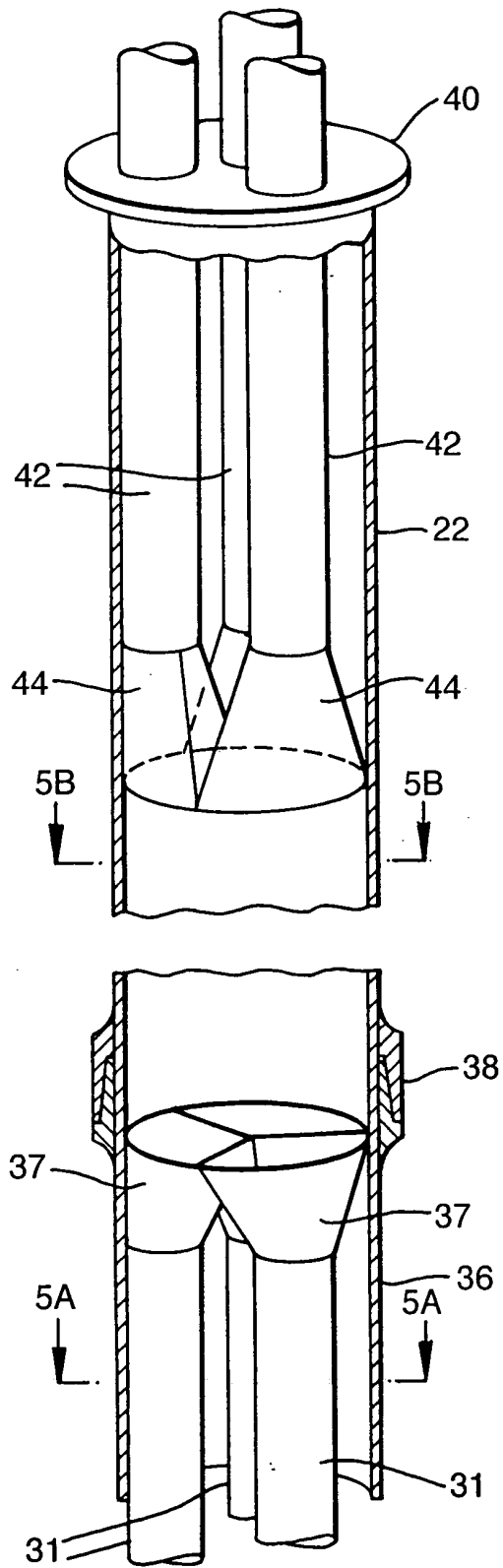

Fig.5A.

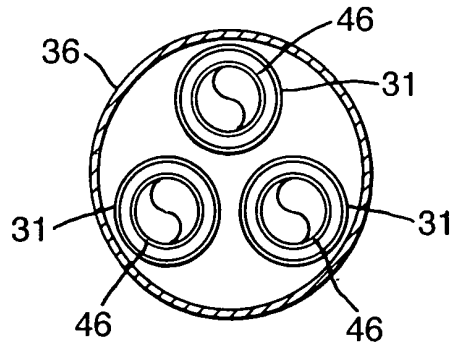

Fig.5B.

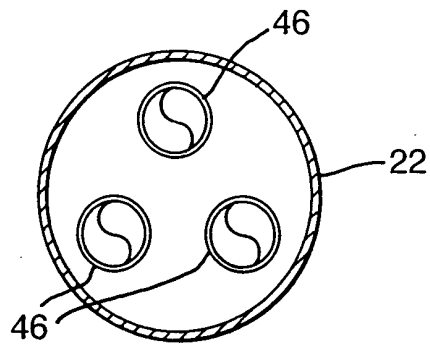

Fig.5C.

