

T. & G. A. PEMBERTON.

Door Bell.

No. 102,035.

Patented April 19, 1870.

Fig. 1.

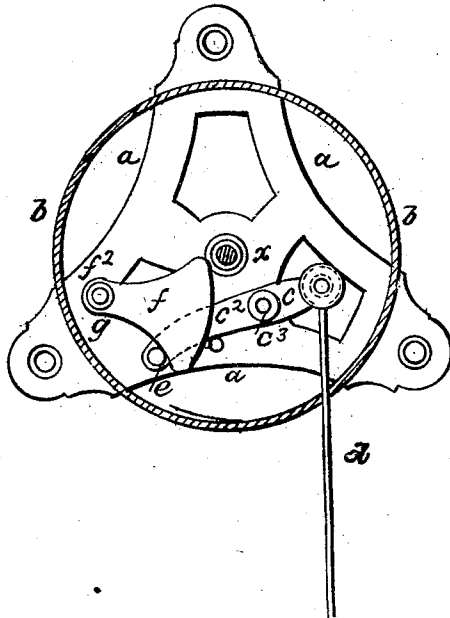

Fig. 2.

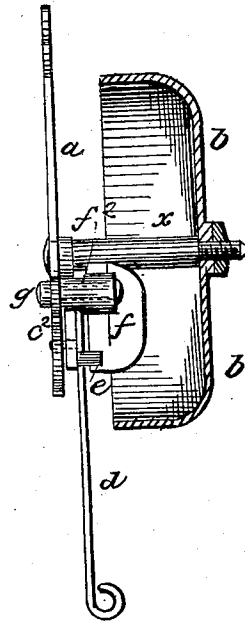

Fig. 3.

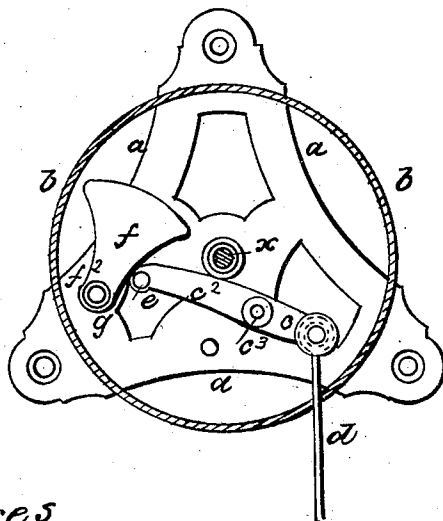
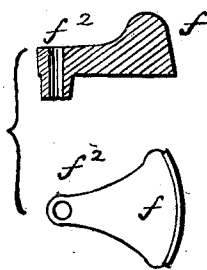

Fig. 4.



Witnesses  
 Richard Knott.  
 Henry Knott.

Inventor  
 Thomas Pemberton  
 by Arthur Pemberton

T. & G. A. PEMBERTON.

Door Bell.

No. 102,035.

Patented April 19, 1870.

Fig 5

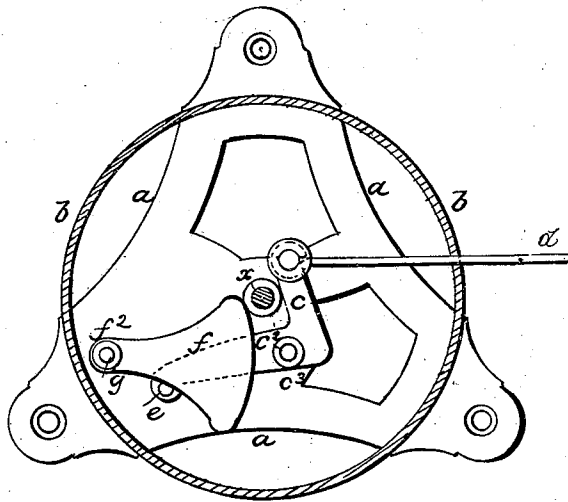
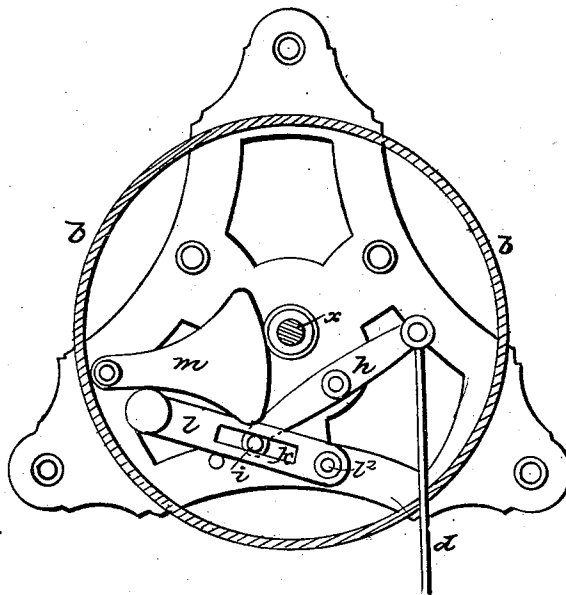

Fig 6



Witnesses

Richard Kerrett  
Henry Kerrett

Inventors

Thomas Pemberton  
Guy Arthur Pemberton

T. & G. A. PEMBERTON.

3 Sheets—Sheet 3.

Door Bell.

No. 102,035.

Patented April 19, 1870.

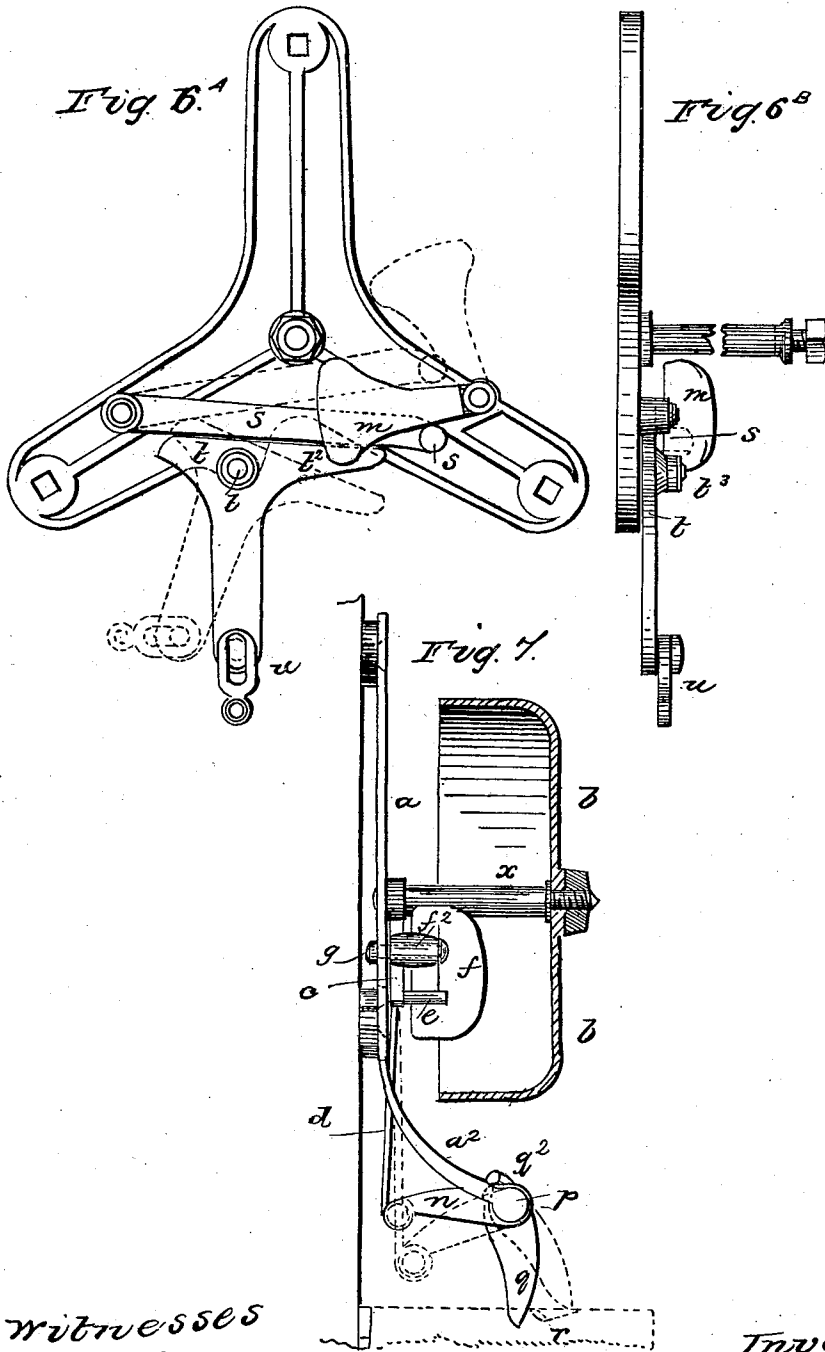

Witnesses  
Richard Kerrett  
Henry Kerrett

Inventor  
Thomas Pemberton  
By [Signature]

# UNITED STATES PATENT OFFICE.

THOMAS PEMBERTON AND GEORGE ARTHUR PEMBERTON, OF BIRMINGHAM,  
ENGLAND.

## IMPROVEMENT IN ALARM AND OTHER BELLS.

Specification forming part of Letters Patent No. 102,035, dated April 19, 1870.

*To all whom it may concern:*

Be it known that we, THOMAS PEMBERTON and GEORGE ARTHUR PEMBERTON, both of Birmingham, in the county of Warwick, England, brass-founders, subjects of the Queen of Great Britain, have invented or discovered new and useful Improvements in Alarm-Bells, Call-Bells, and other Bells; and we, the said THOMAS PEMBERTON and GEORGE ARTHUR PEMBERTON, do hereby declare the nature of the said invention, and in what manner the same is to be performed, to be particularly described and ascertained in and by the following statement thereof—that is to say:

Our invention consists in operating the clappers or hammers of alarm-bells, call-bells, gongs, church-bells, and other bells by means of a lever or levers unattached to the clapper, but so combined therewith as to be restored to their original position without the use of springs after the bell has been struck or rung.

We will describe our invention in connection with an alarm-bell for a door. The bell is fixed in a vertical plane on a horizontal rod carried by a base-plate, as usual, and on the said base-plate a lever is jointed, turning in a vertical plane. To the end of the short arm of the said lever the wire for working the bell is attached, and on the other and long arm of the lever a stud or peg is made at right angles to the said arm. The clapper or hammer of the bell consists of a weighted arm or lever turning in a vertical plane, the end of the said clapper or hammer most distant from the lever hereinbefore described turning on a center on the base-plate of the bell. The bulb or weighted end of the clapper or hammer bears against the stud or peg on the long arm of the lever, and by its weight depresses the said lever, when the latter is at liberty to move. When the wire of the bell is pulled down, the short arm of the lever is depressed and the opposite arm is raised. By the raising of the long arm of the lever the peg or stud on its end raises the clapper or hammer, and, throwing it forcibly against the bell, rings or sounds the said bell, the said peg or stud, as the arm is raised, approaching the center on which the clapper or hammer turns. On loosing the wire of the bell, the lever and parts connected therewith are restored to their original position by

the descent of the clapper or hammer, the said clapper bearing upon the peg or stud on the long arm of the lever.

Having explained the nature of our invention, we will proceed to describe, with reference to the accompanying drawings, the manner in which the same is to be performed.

Figure 1 represents in elevation, partly in horizontal section, an alarm-bell with a vertical pull constructed according to our invention. Fig. 2 is a side elevation, partly in vertical section, of the same. Fig. 3 represents the same view as Fig. 1, but with the parts in the positions which they respectively occupy when the clapper is about striking the bell; and Fig. 4 represents in section and plan the clapper of the bell separately.

The same letters of reference are employed to indicate the same parts in Figs. 1, 2, and 3.

*a* is the base-plate, carrying the bell *b*, the said bell being supported on the horizontal rod *x*.

On the base-plate *a* is a lever, *c c'*, turning in a vertical plane on the center *c'*.

To the arm *c* of the lever the wire *d* is attached for working the bell, and on the end of the other arm, *c'*, of the lever, and at right angles to it, is a stud or peg, *e*.

*f* is the clapper or hammer of the bell, the hollow end or eye *f'* of the said clapper turning in a vertical plane on a pin or center, *g*, carried by the plate *a*. The bulb or weighted end of the clapper or hammer *g*, when it is in its normal position, as represented in Figs. 1 and 2, bears against the said stud *e*, and by its weight depresses the arm *c'* of the said lever.

The action of the bell is as follows: When the wire *d* is pulled down, the arm *c* of the lever is depressed and the other arm, *c'*, is raised. The pin or stud *e* on the said arm *c'* is thereby made to press against and raise the clapper or hammer *f* and throw it forcibly against the bell *b* and ring or sound the said bell, the parts occupying the positions represented in Fig. 3, where the clapper is shown in the act of striking the bell. By an examination of the said Fig. 3 it will be seen that as the peg *e* of the arm *c'* of the lever raises the clapper *f* the said peg approaches the pin or center *g*, on which the said clapper turns, thereby causing the clapper to be thrown with great force

against the bell. After ringing the bell and loosening the wire  $d$ , the clapper  $f$  descends by its own weight, and by pressing on the arm  $c^2$  of the lever restores the parts to their normal positions—that is, to the positions represented in Figs. 1 and 2. When the pull of the bell is required to be in a horizontal direction, the lever  $c^2$  is cranked in the manner represented in Fig. 5, where the parts of the bell are marked with the same letters of reference as corresponding parts in Figs. 1, 2, and 3.

Instead of transmitting the motion of the wire  $d$ , by which the bell is worked, to the clapper through a single lever, as in the arrangements last described, a compound lever may be employed for that purpose, as illustrated in Fig. 6 of the drawings. In this arrangement  $h$  is the lever, to the upper arm of which the wire  $d$ , for pulling the bell, is attached.

On the end of the other arm of the lever  $h$  is a pin or stud,  $i$ , which stud works in a slot,  $k$ , in a second lever,  $l$ , the said second lever turning on a center,  $l^2$ , immediately under the center on which the first lever,  $h$ , turns. By pulling down the lever  $h$  by its wire  $d$  the short arm is raised, thereby lifting the lever  $l$  and causing the latter to raise the clapper  $m$  and ring the bell  $b$ . On loosening the wire  $d$  the compound lever  $l h$  is returned to its normal position by the weight of the clapper  $m$ .

For large gongs, for signaling at railway stations and elsewhere, we employ the arrangement of compound lever represented in front elevation in Fig. 6<sup>A</sup> and side elevation in Fig. 6<sup>B</sup>, (the gong being omitted.) In this arrangement the jointed arm  $s$ , carrying the pin or stud  $s^2$ , which acts upon the clapper  $m$ , is raised by the lever  $t t^2$ , turning on the center  $t^2$ , the said lever being worked by a wire or chain attached to the link  $u$  at the bottom of the said lever. By pulling the said lever  $t t^2$  to the right or left one or other of its arms raises the jointed arm  $s$ , and the pin or stud  $s^2$  of the said arm lifts the clapper and throws it against the gong. The clapper is indicated in dotted lines in its raised position in Fig. 6<sup>A</sup>, the lever  $t t^2$  and arm  $s$  also being indicated in dotted lines. After the gong has been sounded and on loosening the wire by which the lever  $t t^2$  is pulled, the weight of the clapper  $m$  restores the parts to their normal position.

Fig. 7 represents in side elevation, partly in vertical section, an alarm-bell constructed

according to our invention, to be worked or rung by the opening of the door instead of by hand. In this arrangement we attach the wire  $d$ , connected with the lever  $c^2$  of the bell, to an arm,  $n$ , turning on a center or axis,  $p$ , carried by a prolonged part,  $a^2$ , of the base-plate  $a$  of the bell. Also, turning on the center or axis  $p$  is a lever,  $q q^2$ , the short expanded upper arm,  $q^2$ , of which can be made to press upon and depress the arm  $n$ . The lower arm,  $q$ , of the lever  $q q^2$  is situated below the top of the door  $r$ , so that on opening the said door the said lower arm is raised in the manner indicated in dotted lines. Its upper arm is thereby made to depress the arm  $n$ , to which the bell-wire is connected, and cause the bell to be rung. The closing of the door does not affect the bell. The mechanism of this bell is of the kind hereinbefore described, and represented in Figs. 1, 2, and 3.

In applying our invention to other than alarm-bells the parts are constructed and arranged substantially in the manner hereinbefore described, and illustrated in the accompanying drawings, such changes only in the details being made as are necessary to fit the said parts to the kind of bell with which they are to be used.

Having now described the nature of our invention and the manner in which the same is to be performed, we wish it to be understood that we do not limit ourselves to the precise details herein described and illustrated, as the same may be varied without departing from the nature of our invention; but

We claim as our invention the improvements in alarm-bells, call-bells, and other bells hereinbefore described, and illustrated in the accompanying drawings—that is to say:

The combination, with the pivoted clapper or hammer, of an independent single or compound lever, which is unattached to but actuates the hammer, and is restored to its original position by the action of the same, the said lever and clapper or hammer being constructed, arranged, and operating substantially as described and illustrated.

THOMAS PEMBERTON. [L. S.]  
GEORGE ARTHUR PEMBERTON. [L. S.]

Witnesses:

RICHARD SKERRET,  
HENRY SKERRET,

7 Cannon Street, Birmingham.