

No. 863,283.

PATENTED AUG. 13, 1907.

G. J. KAPLAN.
COMBINED CHURN AND BUTTER WORKER.
APPLICATION FILED MAR. 13, 1907.

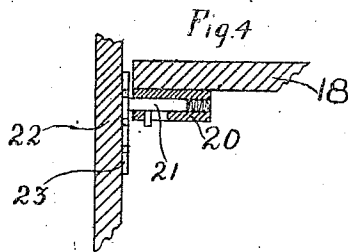
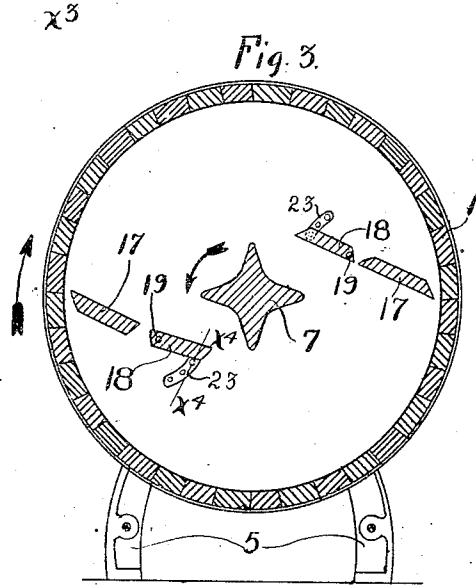
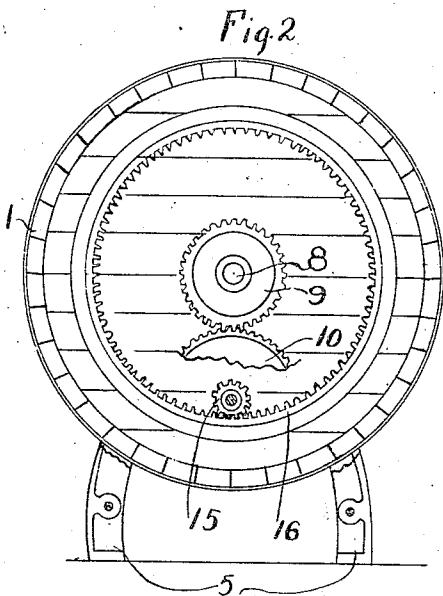
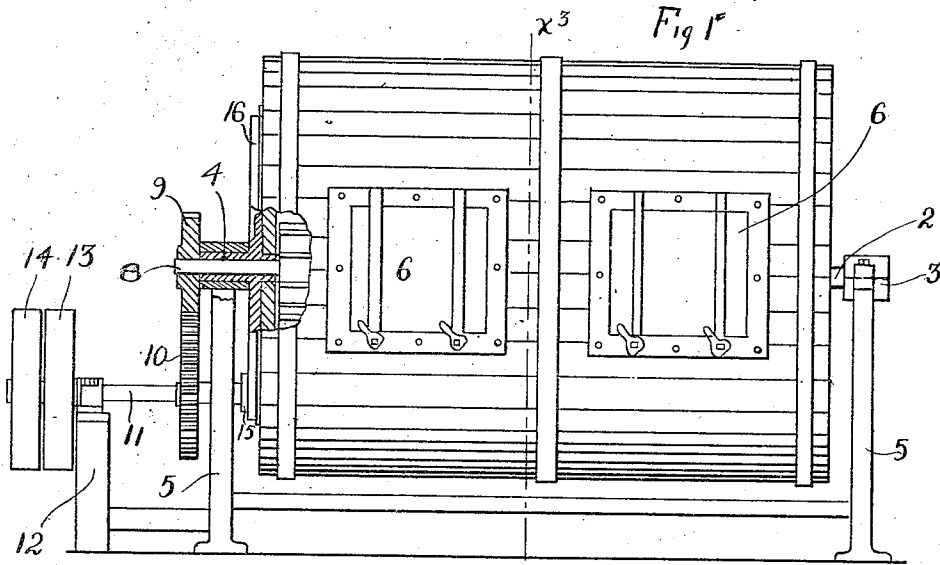

Witnesses:
Leon B. Losey.
L. L. Simpson.

Inventor:
Godfrey Kaplan
By his Attorneys
William M. Mechant

UNITED STATES PATENT OFFICE.

GODFREY J. KAPLAN, OF OWATONNA, MINNESOTA, ASSIGNOR TO PERFECTION CHURN COMPANY, OF OWATONNA, MINNESOTA, A CORPORATION OF MINNESOTA.

COMBINED CHURN AND BUTTER-WORKER.

No. 663,238.

Specification of Letters Patent.

Patented Aug. 13, 1907

Application filed March 13, 1907. Serial No. 363,238.

To all whom it may concern:

Be it known that I, GODFREY J. KAPLAN, a citizen of the United States, residing at Owatonna, in the county of Steele and State of Minnesota, have invented certain new and useful Improvements in Combined Churns and Butter-Workers; and I do hereby declare the following to be a full, clear, and exact description of the invention, such as will enable others skilled in the art to which it appertains to make and use the same.

My present invention has for its object to provide a simple and highly efficient combined churn and butter-worker, and to this end it consists of the novel devices and combinations of devices hereinafter described and defined in the claims.

The improved machine is illustrated in the accompanying drawings, wherein like characters indicate like parts throughout the several views.

Referring to the drawings, Figure 1 shows the improved machine in side elevation, some parts being broken away and some parts being sectioned. Fig. 2 is an end elevation of the improved machine, with some parts broken away and some removed. Fig. 3 is a transverse section taken through the machine on the line $x^3 x^3$ of Fig. 1; and Fig. 4 is a fragmentary view taken in section, approximately on the line $x^4 x^4$ of Fig. 3.

The rotary drum 1 of the machine is horizontally disposed and has fixed heads, one of which heads is provided with a trunnion 2 that is journaled in a suitable bearing of a pedestal bracket 3, while the other head thereof is provided with a hollow trunnion 4 that is journaled in a bearing of a similar pedestal bracket 5. The drum, as shown, is provided with two peripheral openings that are normally closed by tightly clamped doors 6 of the usual or any suitable construction and of which, as is obvious, one or more may be employed.

Within the drum, and extending from one head to the other thereof and journaled on the axis of said drum, is a large deeply corrugated butter-working roller 7. This working roller 7, at one end, is provided with a projecting shaft 8 that is journaled in and extended through the hollow trunnion 4, and is provided at its outer end with a spur gear 9.

Any suitable driving mechanism, either of two speed or a single speed construction, may be used so far as my present invention is concerned, but as illustrated in the drawings, the gear 9 meshes with a gear 10 that is carried by a countershaft 11 mounted in a suitable bearing on the pedestal 5, and in a supplemental bearing pedestal 12. Also, as shown, said countershaft 11 is provided at its outer end with a loose pulley 13 and a rigidly secured pulley 14, and at its inner end

with a spur pinion 15 that meshes with an internal ring gear 16 secured to and carried by the adjacent head of the drum. By the driving gear described, the drum will be rotated in one direction, and the working roller 7 will be rotated in an opposite direction, but at a relatively high speed with respect to the rotation of the drum. Motion may, of course, be transmitted to the machine from a power-driven belt, not shown, but which when the machine is in action would run upon the fixed pulley 14, and when the machine is idle would run upon the idle pulley 13.

Within the drum, adjacent to the cylindrical shell of the drum and preferably at diametrically opposite points, are so-called lifting flights 17 which at their ends are rigidly secured to the fixed heads of the drum. These lifting flights 17 are set obliquely in respect to radial lines drawn from the common axis of the drum and working roller, and their inner edges are inclined backward in respect to the direction in which the drum is rotated when in action. The directions in which the drum and working rollers are rotated when the machine is in action are indicated by the arrows marked adjacent to the respective parts in Fig. 3.

The lifting flights 17 are arranged to raise the butter on the rising side of the drum and to deliver the same onto the so-called working shelves 18, which working shelves, in a sense, constitute extensions of the said lifting flights, but are preferably spaced apart therefrom, so as to leave a space or gap through which part of the liquid pressed or running from the butter may freely pass. These working shelves, like the lifting flights, are supported at their ends by the fixed heads of the drum, but they are preferably made pivotally adjustable so that the distance between their inner edges and the circular line of travel of the outer portions of the working roller 7 may be varied. To this end, the said working shelves, at the end portions of their outer edges, are pivotally connected by trunnions or otherwise to the fixed heads of the drum, as indicated at 19, and at the ends of their inner edges they are provided with bolt housings 20 in which spring pressed lock bolts 21 are mounted for sliding movements toward and from adjacent drum heads, for engagement and disengagement with perforations or seats 22 of latch plates 23 rigidly secured to the inner surface of the said drum heads. The distance which the inner edges of the working shelves 18 will be set with respect to the working roller will depend largely on the amount of butter that is being churned.

In the churning action, the lifting flights and working shelves are dashed against the cream on the lowering side of the drum and on the rising side of the drum they raise the cream and then allow the same to be

dashed violently inward and downward. In brief, the cream is subjected to intense agitation under the rotation of the drum and the action thereon of the said lifting flights and working shelves, and this is so whether or not the working roller is at such time kept under rotation. The agitation is, however, very greatly increased by keeping the working roller under rotation in the churning action.

With the construction described, in the butter-working action, the butter picked up and elevated on the rising side of the drum by the upwardly moving lifting flight 17 will be delivered onto the adjacent working shelf 18, and the butter thus interposed between said upwardly moving working table and the working roller 7 will, under the rotation of said roller, be pressed or squeezed directly against the said working shelf, and as each projecting rib or blade of the said roller passes the said working shelf, a long strip or bar-like body will be cut from the butter which is being raised and will be forced below the said working shelf and dropped to the bottom of the drum. Under this compressing action between the working roller and working shelf, the buttermilk is squeezed from the butter, and when salt is applied the salt will be thoroughly commingled and evenly mixed throughout the body of the butter. In fact, in practice I have found that a very material saving in salt is accomplished by the use of this machine, which is undoubtedly due to the fact that nearly all of the salt introduced into the churn, in the butter-working action, is mixed into the butter, so that a very much less amount of salt is carried off in the form of brine.

The thorough commingling of the salt is due to the fact that successive strips or bars of butter cut from the body which is being raised are, under the successive actions of the pairs of lifting flights and working shelves in cooperation with the working roller, collected and pressed together and then separated again in such a way as to effect a continuous rearrangement of the body of butter.

What I claim is:

1. The combination with a horizontally disposed drum, of a single axially disposed working roller within said drum, one or more lifting and working abutments extended longitudinally within said drum between said working roller and the shell of the drum, positioned obliquely with respect to a radial line drawn from the axis of said roller, and inclining at its inner edge backward with respect to the direction of the rotation of said drum, and means for rotating said drum and working roller in reverse directions, the latter at a higher speed than the former and in a direction for cooperation with said abutment, to work the butter on the rising side of the drum, substantially as described.

2. The combination with a horizontally disposed drum,

of an axially located working roller within said drum, a lifting flight extending longitudinally within said drum adjacent to the shell thereof, a working shelf or abutment also extended longitudinally within said drum, arranged to receive from said lifting flight and to cooperate with said working roller, and means for rotating said drum and working roller in reverse directions, the latter at a higher speed than the former, and in a direction for cooperation with said working shelf or abutment to work the butter on the rising side of the drum, substantially as described.

3. The combination with a horizontally disposed drum, of a single axially disposed working roller within said drum, a lifting flight extended longitudinally within said drum, adjacent to the shell thereof, a working shelf or abutment also extended longitudinally within said drum, arranged to receive from said lifting flight and to cooperate with said roller in the butter working action, said lifting flight and working shelf or abutment inclining at their inner edges backward with respect to the direction of the rotation of the drum, the former at a greater angle than the latter to lines drawn radially therethrough from the axis of the drum, and means for rotating said drum and working roller, in reverse directions, the latter at a higher speed than the former, and in a direction for cooperation with said working shelf or abutment, to work the butter on the rising side of the drum, substantially as described.

4. The combination with a horizontally disposed drum, of a centrally disposed working roller within said drum, a lifting flight extended longitudinally within said drum, adjacent to the shell thereof, and an adjustable working shelf also extended longitudinally within said drum, and arranged to receive the butter from said lifting flight and to cooperate with said working roller in the butter-working action, and means for rotating said drum and working roller in reverse directions, the latter at a higher speed than the former, substantially as described.

5. The combination with a horizontally disposed drum, of a centrally located working roller within said drum, a plurality of lifting flights within said drum, adjacent to the shell thereof, corresponding working shelves adjustably mounted within said drum, located inward of the respective lifting flights and arranged to cooperate, in succession, with said working roller, and means for rotating said drum and working roller in reverse directions, the latter at a higher speed than the former, substantially as described.

6. The combination with a horizontally disposed drum, of a centrally located working roller within said drum, a lifting flight within said drum, adjacent to the shell thereof, a working shelf within said drum, inward of said lifting flight, which shelf is pivoted to the heads of the drum at the ends of its outer edge portion, and is provided at the ends of its inner edge portion with latches adjustably engageable with seats carried by the heads, and means for rotating said drum and working roller in reverse directions, the latter at a higher speed than the former, substantially as described.

In testimony whereof I affix my signature in presence of two witnesses.

GODFREY J. KAPLAN.

Witnesses:

F. A. DUNHAM,
S. G. KINNEY.