

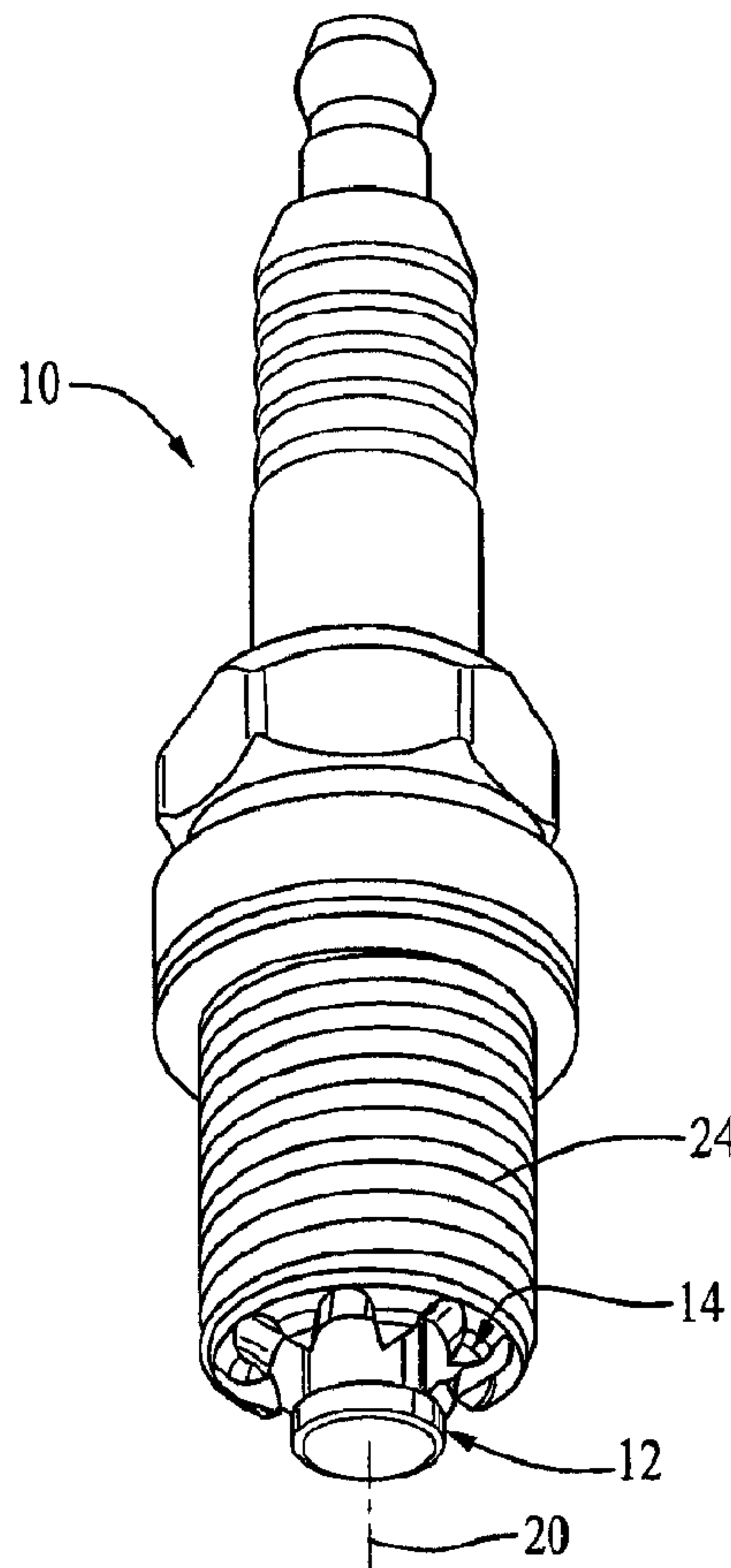

(86) **Date de dépôt PCT/PCT Filing Date:** 2010/08/23
 (87) **Date publication PCT/PCT Publication Date:** 2012/03/01
 (45) **Date de délivrance/Issue Date:** 2016/02/09
 (85) **Entrée phase nationale/National Entry:** 2013/02/20
 (86) **N° demande PCT/PCT Application No.:** US 2010/046386
 (87) **N° publication PCT/PCT Publication No.:** 2012/026919

(51) **Cl.Int./Int.Cl. H01T 13/20** (2006.01)
 (72) **Inventeurs/Inventors:**
 MARTIN, PERRY D., US;
 WITHERSPOON, CHRISTOPHER J., US
 (73) **Propriétaire/Owner:**
 VOMAR TECH, INC., US
 (74) **Agent:** BORDEN LADNER GERVAIS LLP

(54) **Titre : BOUGIE D'ALLUMAGE**
 (54) **Title: SPARK PLUG**



(57) **Abrégé/Abstract:**

A spark plug (10) has a central electrode (12) and a plurality of peripheral electrodes 14. Each peripheral electrode (14) has a lower portion (25) and an upper portion (26). Each upper portion (26) has a distal-most point (28). Each distal-most point (28) is

(57) Abrégé(suite)/Abstract(continued):

disposed in a central plane (30) within which the longitudinal axis (20) of the distal portion (18) of the central electrode (12) is wholly disposed. The cross-section of each upper portion (26) taken along its central plane (30) defines a convex outer side (32) and a non-convex inner side (34). Each convex outer side (33) has a curved surface (36) which is tangent to a plurality of tangent planes (38), all of which intersect the longitudinal axis (30) of the distal portion (18) of the central electrode (12) at points at or above the distal end (22) of the distal point of the central electrode (12).

(12) INTERNATIONAL APPLICATION PUBLISHED UNDER THE PATENT COOPERATION TREATY (PCT)

(19) World Intellectual Property Organization
International Bureau(43) International Publication Date
1 March 2012 (01.03.2012)(10) International Publication Number
WO 2012/026919 A1(51) International Patent Classification:
H01T 13/20 (2006.01)(21) International Application Number:
PCT/US2010/046386(22) International Filing Date:
23 August 2010 (23.08.2010)

(25) Filing Language: English

(26) Publication Language: English

(71) Applicant (for all designated States except US): **VO-MAR TECH, INC.** [US/US]; P.O. Box 2893, Big Bear Lake, CA 92315 (US).

(72) Inventors; and

(75) Inventors/Applicants (for US only): **MARTIN, Perry, D.** [US/US]; 8295 Mesa Linda Street, Oak Hills, CA 92344 (US). **WITHERSPOON, Christopher, J.** [US/US]; 6139 Deep Creek Road, Apple Valley, CA 92308 (US).(74) Agents: **ANDERSON, Denton, L.** et al.; Sheldon Mak & Anderson PC, 100 Corson Street, Third Floor, Pasadena, CA 91103-3842 (US).

(81) Designated States (unless otherwise indicated, for every kind of national protection available): AE, AG, AL, AM, AO, AT, AU, AZ, BA, BB, BG, BH, BR, BW, BY, BZ, CA, CH, CL, CN, CO, CR, CU, CZ, DE, DK, DM, DO, DZ, EC, EE, EG, ES, FI, GB, GD, GE, GH, GM, GT, HN, HR, HU, ID, IL, IN, IS, JP, KE, KG, KM, KN, KP, KR, KZ, LA, LC, LK, LR, LS, LT, LU, LY, MA, MD, ME, MG, MK, MN, MW, MX, MY, MZ, NA, NG, NI, NO, NZ, OM, PE, PG, PH, PL, PT, RO, RS, RU, SC, SD, SE, SG, SK, SL, SM, ST, SV, SY, TH, TJ, TM, TN, TR, TT, TZ, UA, UG, US, UZ, VC, VN, ZA, ZM, ZW.

(84) Designated States (unless otherwise indicated, for every kind of regional protection available): ARIPO (BW, GH, GM, KE, LR, LS, MW, MZ, NA, SD, SL, SZ, TZ, UG, ZM, ZW), Eurasian (AM, AZ, BY, KG, KZ, MD, RU, TJ, TM), European (AL, AT, BE, BG, CH, CY, CZ, DE, DK, EE, ES, FI, FR, GB, GR, HR, HU, IE, IS, IT, LT, LU, LV, MC, MK, MT, NL, NO, PL, PT, RO, SE, SI, SK, SM, TR), OAPI (BF, BJ, CF, CG, CI, CM, GA, GN, GQ, GW, ML, MR, NE, SN, TD, TG).

Published:

— with international search report (Art. 21(3))

(54) Title: SPARK PLUG

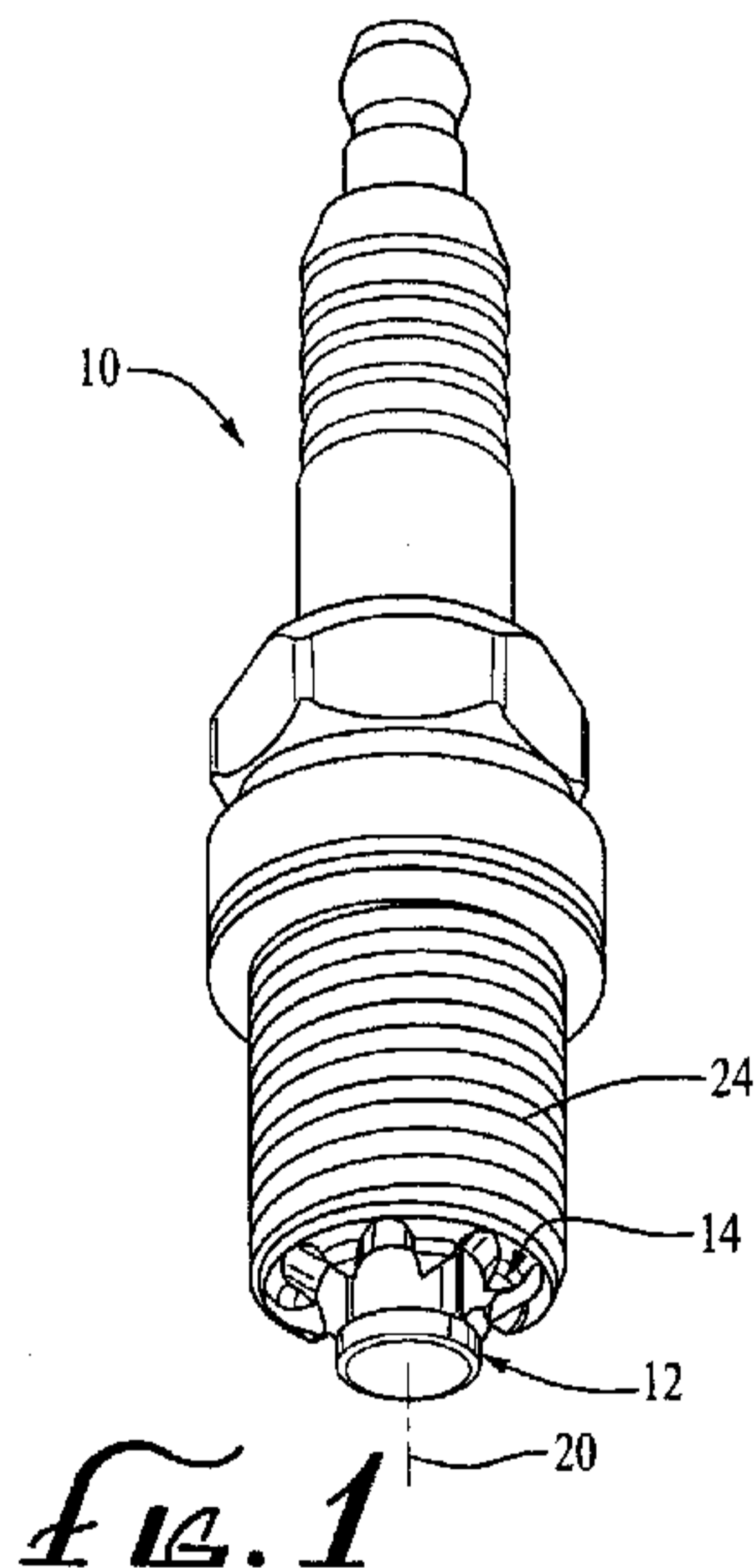

(57) Abstract: A spark plug (10) has a central electrode (12) and a plurality of peripheral electrodes 14. Each peripheral electrode (14) has a lower portion (25) and an upper portion (26). Each upper portion (26) has a distal-most point (28). Each distal-most point (28) is disposed in a central plane (30) within which the longitudinal axis (20) of the distal portion (18) of the central electrode (12) is wholly disposed. The cross-section of each upper portion (26) taken along its central plane (30) defines a convex outer side (32) and a non-convex inner side (34). Each convex outer side (33) has a curved surface (36) which is tangent to a plurality of tangent planes (38), all of which intersect the longitudinal axis (30) of the distal portion (18) of the central electrode (12) at points at or above the distal end (22) of the distal point of the central electrode (12).

SPARK PLUG

5

10

FIELD OF THE INVENTION

The invention relates generally to spark plugs for internal combustion engines.

15

BACKGROUND OF THE INVENTION

Spark plugs for internal combustion engines have been known for more than 100 years. Although the design of spark plugs has improved considerably during that time, there is a continuing need for spark plugs which will further enhance engine performance and, hopefully, reduce the rate of fuel consumption.

20

25

The need for spark plugs which yield improved engine performance is especially acute in the racing industry, where even small increases in engine performance and/or small decreases in engine fuel consumption can mean the difference between winning and losing.

5

SUMMARY OF THE INVENTION

The invention satisfies this need. The invention is a spark plug comprising (a) a central electrode having a proximal portion and a distal portion, the distal portion having a circular cross section with a longitudinal axis and terminating in a distal end; and (b) a plurality of peripheral electrodes, each peripheral electrode having a lower portion and an upper portion and being substantially identical in shape and dimensions, each upper portion having a distal-most point, each distal-most point being disposed in a central plane within which the longitudinal axis of the distal portion of the central electrode is wholly disposed, the cross-section of each upper portion taken along its central plane defining a convex outer side and a non-convex inner side, each convex outer side having a curved surface which is tangent to a plurality of tangent planes, all of which tangent planes intersect the longitudinal axis of the distal portion of the central electrode at points at or above the distal end of the distal point of the central electrode.

20

DRAWINGS

These and other features, aspects and advantages of the present invention will become better understood with reference to the following description, appended claims and accompanying drawings where:

25

Figure 1 is a perspective view of a spark plug having features of the invention;

Figure 2 is a plan view of one end of the spark plug illustrated in Figure 1;

30

Figure 3A is a cross-sectional view of the spark plug illustrated in Figure 2, taken along line 3-3;

Figure 3B is an alternative cross-sectional view of the spark plug illustrated in Figure 2, take along line 3-3;

35

5 Figure 4A is diagrammatic illustration of a first lower portion of a peripheral electrode useable in the invention;

 Figure 4B is a diagrammatic illustration of a second lower portion of a peripheral electrode useable in the invention;

10

 Figure 4C is a diagrammatic illustration of a third lower portion of a peripheral electrode useable in the invention;

 Figure 4D is a diagrammatic illustration of a fourth lower portion of a peripheral electrode useable in the invention;

15

 Figure 4E is a diagrammatic illustration of a fifth lower portion of a peripheral electrode useable in the invention;

 Figure 4F is a diagrammatic illustration of a sixth lower portion of a peripheral electrode useable in the invention;

20

 Figure 4G is a diagrammatic illustration of a seventh lower portion of a peripheral electrode useable in the invention;

25

 Figure 4H is a diagrammatic illustration of an eighth lower portion of a peripheral electrode useable in the invention;

 Figure 4I is a side view of the lower portion of the peripheral electrode illustrated in Figure 4H;

30

 Figure 4J is a diagrammatic illustration of an ninth lower portion of a peripheral electrode useable in the invention;

 Figure 4K is a side view of the lower portion of the peripheral electrode illustrated in Figure 4J;

35

5 Figure 4L is a diagrammatic illustration of a tenth lower portion of a peripheral electrode useable in the invention;

 Figure 4M is a side view of the lower portion of the peripheral electrode illustrated in Figure 4L;

10

 Figure 4N is an alternative side view of the lower portion of the peripheral electrode illustrated in Figure 4L.

15

DETAILED DESCRIPTION

 The following discussion describes in detail one embodiment of the invention and several variations of that embodiment. This discussion should not be construed, however, as limiting the invention to those particular embodiments. Practitioners skilled in the art will recognize numerous other embodiments as well.

20

 As used herein, except where the context requires otherwise, the term "comprise" and variations of the term, such as "comprising," "comprises" and "comprised" are not intended to exclude other additives, components, integers or steps. Thus, throughout this specification, unless the context requires otherwise, the words "comprise", "comprising" and the like, are to be construed in an inclusive sense as opposed to an exclusive sense, that is to say, in the sense of "including, but not limited to".

25

 As depicted in the figures, all dimensions specified in this disclosure are by way of example only and are not intended to be limiting. Further, the proportions shown in these figures are not necessarily to scale. As will be understood by those with skill in the art with reference to this disclosure, the actual dimensions of any device or part of a device disclosed in this disclosure will be determined by its intended use.

30

35

5

5 The invention is a spark plug 10 for an internal combustion engine which is capable of providing extraordinary performance. The spark plug 10 comprises a central electrode 12 and a plurality of peripheral electrodes 14. The invention is illustrated in Figures 1-3.

10 The central electrode 12 has a proximal portion 16 and a distal portion 18. The distal portion 18 has a circular cross-section with a longitudinal axis 20. The distal portion 18 terminates at a distal end 22. In one embodiment, the distal end 22 of the central electrode 12 is dome-shaped for a congruous blunt shape. For ease of manufacturing, the central electrode 12 is cylindrical as with a typical spark plug.

15 In a preferred embodiment, the diameter of the distal portion 18 is between about 0.125 inches and about 0.265 inches. This diameter of the distal portion 18 is about two to three times larger than in a typical spark plug. The central electrode 12 is enlarged for several reasons. One purpose is for spark stabilization. The enlarged electrode stores up more
20 energy, thereby releasing a greater amount of electricity at the spark event. A second purpose is to cause continuous rapid ion movement during the ignition cycle that will not break down, even under extreme combustion pressure, as with racing engines.

25 The plurality of peripheral electrodes 14 are disposed equidistant from one another around the central electrode 12 so as to define a circle having the central electrode 12 disposed at its center. The peripheral electrodes 14 are typically integral with a threaded base cylinder 24. In the embodiment illustrated in the drawings, the plurality of peripheral electrodes 14 constitutes 8 peripheral electrodes 14. In all cases, it is important that the number of peripheral electrodes 14 is between about 3 and about 12. When the number of peripheral
30 electrodes 14 is less than 3 or greater than 12, performance in an internal combustion engine is markedly reduced.

35 Each of the peripheral electrodes 14 is substantially identical in shape and dimensions. Each peripheral electrode 14 has a lower portion 25 and an upper portion 26. The upper portion 26 has a distal-most point 28. As illustrated in Figures 1 and 2, the distal-most point 28 of each of the peripheral electrodes 14 can be relatively sharp. However, in other

5 embodiments, the distal-most point 28 of each of the peripheral electrodes 14 may be more rounded or flat.

10 As illustrated in Figure 2, each distal-most point 28 is disposed in a central plane 30 within which the longitudinal axis 20 of the distal portion 18 of the central electrode 12 is wholly disposed. The cross-section of each upper portion 26 of each of the peripheral electrodes 14, taken along its central plane 30, defines a convex outer side 32 and a non-convex inner side 34.

15 As illustrated in Figure 3A, each convex outer side 32 has a curved surface 36 which is tangent to a plurality of tangent planes 38, all of which tangent planes 38 intersect the longitudinal axis 20 of the distal portion 18 of the central electrode 12 at points at or above the distal end 22 of the distal point of the central electrode 12. In a typical embodiment, the curved surface 36 of the convex outer side 32 is smooth with preferably no discontinuities.

20 Figure 3B illustrates an alternative cross-sectional view identical to that which is illustrated in Figure 3A, except that the inner side 34 defines a small flat section 37 near the distal-most point 28.

25 By the aforementioned design, the plurality of peripheral electrodes 14 resembles a fork that has been bent into a loop with the tines arcing inwards to point at the central electrode 12.

30 As also illustrated in Figure 3, the peripheral electrodes 14 are electrically insulated from the central electrode 12 by a layer of bakelite 40 or other suitable insulator.

35 As illustrated in Figures 4A-4M, the peripheral electrodes 14 can be provided in a variety of shapes. Figure 4A illustrates the cross-sectional shape of the lower portion 25 of a peripheral electrode 14 having a generally square cross-section. Figure 4B illustrates the lower portion 25 of a peripheral electrode 14 having a generally rectangular cross-section. Figure 4C illustrates the lower portion 25 of a peripheral electrode 14 having a generally oval shape. Figure 4D illustrates the lower portion 25 of a peripheral electrode 14 having a generally

5 circular shape. Figure 4E illustrates the lower portion 25 of a peripheral electrode 14 having a generally square shape but with rounded corners. Figure 4F illustrates the lower portion 25 of a peripheral electrode 14 having a generally rectangular cross-section, but with rounded corners. Figure 4G illustrates the lower portion 25 of a peripheral electrode 14 having a generally triangular cross-section.

10

Figures 4H and 4I illustrates the upper portion 26 of a peripheral electrode 14 having the shape of an eccentric cone. Similarly, Figures 4J and 4K illustrate the upper portion 26 of a peripheral electrode 14 having a shape of an alternative eccentric cone.

15

Figures 4L and 4M illustrate the upper portion 26 of a peripheral electrode 14 having a generally flat inner side 34 and an outer side 32 which in cross-section taken along its central plane 30, the inner side 34 has a generally flat surface and the outer side 32 has a surface having the shape of a circular arc.

20

Figure 4N illustrates the cross-section of an alternative upper portion 26 of the peripheral electrode 14 illustrated in Figure 4L wherein the inner side 34 is somewhat concave.

25

Typically, the distal-most point 28 of each of the peripheral electrodes 14 is spaced apart from the central electrode 12 by a distance of between about 0.04 inches and about 0.095 inches, most typically between about 0.05 inches and about 0.07 inches.

30

By the above-described unique design of the spark plug 10 of the invention, the spark plug 10 is capable of providing improved engine performance, including the increasing of horsepower and torque, by utilizing the excess energy from an ignition source to cause rapid ion movement that mixes with the incoming air/fuel in the combustion chamber. A blast of negative ions is mixed into the air fuel in the combustion chamber just prior to ignition, during the spark event and during combustion. This blast of ions changes the burn characteristics of the fuel by releasing more potential energy and slowing down the actual combustion event.

35

This phenomenon is similar to raising the octane level of the fuel. During the firing event ions are cooling the tips. This event often results in rapid circular flow around the central electrode.

8

5 This phenomenon has the further advantage that the spark plug of the invention need not be designed for one of a large number of specific heat ranges. For most applications, only one heat range is required. In contrast, with conventional spark plugs, as many as 20 different designs are required, one for a different heat range.

10 By the design of the peripheral electrodes in the invention, negative ions are separated out of the electrical charge flowing from the coil. The ions travel along the periphery of the negative electrodes, building momentum along the curves of the peripheral electrodes culminating at the distal portion and then blasting a pathway toward the center electrode for the spark plasma to travel. As the piston nears top dead center of the compression/combustion
15 stroke the combustion chamber becomes highly pressurized. In this atmosphere the spark plasma is amplified and split so a plurality of sparks are emitted from the variety of the ground electrodes. As many as three distinct, highly energized spark kernels have been observed during high pressure testing.

20 The rapid ion movement impacts upon the central electrode and splays out into the air/fuel charge, heavily ionizing said charge before, during and shortly after the spark event. Thus fully utilizing, completely, the electrical charge provided by the coil.

25 Another phenomenon that occurs in the use of the invention is that the moving ions create a pressure shield beneath the central electrode and in the cavity between the insulator and the inner wall of the base shell. This pressure shield keeps carbon from partially burnt fuel and oil from contaminating the insulator and the inner wall of the base shell, thus avoiding potential shorting of the spark.

30 After ignition, the rapid ion movement cools down the flame front, thus slowing down the combustion event. This rapid ion movement process causes an increased duration of pressure on the descending piston top. This rapid ion movement combustion process also ensures a more complete burn, thus lowering the percentage of unburned hydrocarbons.

35

5 Another positive benefit concerning emissions is that the cooling aspect of the rapid ion movement keeps the NO_x from rising. This is contrasted with conventional spark plugs wherein a higher heat range must be utilized to burn more hydrocarbons (and such higher heat necessarily produces more NO_x).

10 Finally, the design of the invention also produces a very strong and stable spark that can jump large spark gaps and under extreme combustion pressure, thereby greatly reducing misfires.

EXAMPLES

15 Dynometer charts are re-produced utilizing a high performance V-8 test engine. These tests were conducted by an independent facility. No changes or alterations were made to the engine with the exception of the changing of spark plugs.

20 These charts demonstrate the increase in horsepower and torque achieved by the sparkplug of the invention compared to a typical racing spark plug of the prior art.

Example 1

25 In this example, the engine for testing was a 420 cubic inch Ford FE engine with an 850 cfm Holly carburetor and 38 degrees of timing. The stock spark plugs were Autolite 3924 stock plugs set at a gap of .040 inches. The spark plugs of the invention were Autolite 3924 stock plugs modified as illustrated in Figure 1, with a gap of .058 inches.

	<u>Stock Plug</u>			<u>Invention Plug</u>	
	<u>RPM</u>	<u>Trq</u>	<u>Pwr</u>	<u>Trq</u>	<u>Pwr</u>
	3900	470.7	349.5	462.7	343.6
	4000	505.1	384.7	503.5	383.4
35	4100	500.6	390.8	505.5	394.6
	4200	499.8	399.7	507.6	405.9
	4300	499.5	408.9	503.7	412.4
	4400	498.2	417.4	501.8	420.4
	4500	502.0	430.1	508.3	435.5

10

5	<u>RPM</u>	<u>Trq</u>	<u>Pwr</u>	<u>Trq</u>	<u>Pwr</u>
	4600	512.8	449.2	511.9	448.3
	4700	516.2	461.9	523.0	468.0
	4800	514.9	470.6	522.0	477.1
	4900	519.0	484.2	521.7	486.7
10	5000	518.8	493.9	525.4	500.2
	5100	520.9	505.8	522.4	507.3
	5200	523.2	518.0	520.5	515.3
	5300	519.4	524.1	524.3	529.1
	5400	514.2	528.7	521.4	536.1
15	5500	514.3	538.6	518.6	543.1
	5600	505.6	539.1	511.7	545.6
	5700	500.0	542.6	501.6	544.4
	5800	493.5	545.0	493.1	544.6
	5900	483.5	543.1	487.0	547.1
20	6000	476.6	544.5	481.6	550.1
	6100	471.4	547.5	469.4	545.2
	6200	462.3	545.8	462.2	545.6
	6300	452.7	543.0	458.0	549.4
	6400	447.3	545.1	446.5	544.1
25	6500	437.6	541.6	435.8	539.3

Example 2

The engine for testing was an 812 cubic inch Ford engine with an 850 cfm Holly carburetor and 38 degrees of timing. The stock spark plugs were Autolite 3924 stock plugs set at a gap of 0.45 inches. The spark plugs of the invention were Autolite 3924 stock plugs modified as illustrated in Figure 1, with a gap of .062 inches. In Example 2, two tests were run with the spark plugs of the invention.

35		<u>Stock</u>		<u>Invention 1</u>		<u>Invention 2</u>
	<u>RPM</u>	<u>Trq</u>	<u>Pwr</u>	<u>Trq</u>	<u>Pwr</u>	<u>Trq</u>
	4000	495.9	377.6	496.6	378.2	506.0
	4100	505.4	394.5	496.9	387.9	504.1
40	4200	503.5	402.6	501.1	400.7	505.0
	4300	506.1	414.4	498.9	408.5	511.2
	4400	511.9	428.9	508.8	426.2	510.0
	4500	513.5	440.0	514.4	440.7	511.4
	4600	512.3	448.7	515.4	451.5	517.6
45	4700	523.3	468.3	519.4	464.8	526.2
	4800	530.2	484.6	531.2	485.4	527.9

11

	<u>RPM</u>	<u>Trq</u>	<u>Pwr</u>	<u>Trq</u>	<u>Pwr</u>	<u>Trq</u>	<u>Pwr</u>
5	4900	528.6	493.2	529.7	494.2	527.1	491.8
	5000	534.2	508.6	533.3	507.8	530.1	504.7
	5100	530.9	515.5	531.4	516.1	532.9	517.5
	5200	529.5	524.2	533.9	528.6	529.6	524.4
10	5300	524.1	528.9	528.1	532.9	526.9	531.7
	5400	520.1	534.8	523.2	538.0	522.4	537.1
	5500	519.2	543.7	523.2	547.9	517.8	542.2
	5600	512.7	546.7	518.7	553.0	505.9	539.4
	5700	498.7	541.3	511.1	554.7	503.7	546.7
15	5800	497.3	549.2	502.7	555.1	495.6	547.4
	5900	494.1	555.0	493.6	554.4	492.8	553.6
	6000	483.7	552.6	488.8	557.9	489.3	559.0

20 Having thus described the invention, it should be apparent that numerous structural modifications and adaptations may be resorted to without departing from the scope and fair meaning of the instant invention as set forth hereinabove and as described hereinbelow by the claims.

5 **CLAIMS:**

1. A spark plug comprising:

(a) a central electrode having a proximal portion and a distal portion, the distal portion having a circular cross section with a longitudinal axis and terminating in a distal end;

10 (b) a plurality of peripheral electrodes, each peripheral electrode having a lower portion and an upper portion and being substantially identical in shape and dimensions, each upper portion having a distal-most point, each distal-most point being disposed in a central plane within which the longitudinal axis of the distal portion of the central electrode is wholly disposed, the cross-section of each upper portion taken along its central plane defining a convex outer side and a non-convex inner side, each convex outer side having a curved surface
15 which is tangent to a plurality of tangent planes,

characterised in that the shape of the curved surface of each convex outer side of the upper portion of each peripheral electrode is such that all of said tangent planes intersect the longitudinal axis of the distal portion of the central electrode at points at or above the distal end of
20 the distal point of the central electrode;

in that either the inner side of the upper portion of each peripheral electrode has a generally flat surface or the upper portion of each peripheral electrode has the shape of an eccentric cone; and

25 the inner side of each peripheral electrode defines a flat section near each distal-most point.

2. A spark plug according to claim 1 wherein the distal portion of the central electrode has a diameter between about 0.125 inches and about 0.265 inches.

30 3. A spark plug according to claim 1 wherein the central electrode has a distal end which is dome-shaped.

4. A spark plug according to claim 1 wherein the number of the plurality of peripheral electrodes is between 3 and 12 peripheral electrodes.

- 5 5. A spark plug according to claim 1 wherein the lower portion of each of the
peripheral electrodes has a square cross-section.
6. A spark plug according to claim 1 wherein the lower portion of each of the
peripheral electrodes has a rectangular cross-section.
- 10 7. A spark plug according to claim 1 wherein the lower portion of each of the
peripheral electrodes has a generally oval cross-section.
8. A spark plug according to claim 1 wherein the lower portion of each of the
15 peripheral electrodes has a circular cross-section.
9. A spark plug according to claim 1 wherein the lower portion of each of the
peripheral electrodes has a generally square cross-section with rounded corners.
- 20 10. A spark plug according to claim 1 wherein the lower portion of each of the
peripheral electrodes has a generally rectangular cross-section with rounded corners.
11. A spark plug according to claim 1 wherein the lower portion of each of the
peripheral electrodes has a generally triangular cross-section with rounded corners.
- 25 12. A spark plug according to claim 1 wherein the convex outer side is
smooth.
- 30 13. A spark plug according to claim 12 wherein the convex outer side forms
an arc of a circle.
14. A spark plug according to claim 1 wherein the central electrode is
surrounded by an insulator and wherein the distal end of the central electrode extends axially
35 beyond a distal end of the insulator and has a width substantially equal to the width of the distal
end of the insulator.

