



- (51) International Patent Classification:  
*G02B 7/00* (2006.01)      *G02B 7/02* (2006.01)
- (21) International Application Number:  
PCT/EP2017/061108
- (22) International Filing Date:  
10 May 2017 (10.05.2017)
- (25) Filing Language: English
- (26) Publication Language: English
- (30) Priority Data:  
16169093.8      11 May 2016 (11.05.2016)      EP
- (71) Applicant: AUTOLIV DEVELOPMENT AB [SE/SE];  
Wallentinsvägen 22, 44783 Vargarda (SE).
- (72) Inventors: KNUTSSON, Per; Bygdegatan 276, 58331  
Linköping (SE). FREDRIKSSON, Peter; Mjärdevigatan,  
58422 Linköping (SE).
- (74) Agent: KOCH, Henning; Otto-Hahn-Str. 4, 25337  
Elmshorn (DE).

- (81) Designated States (unless otherwise indicated, for every kind of national protection available): AE, AG, AL, AM, AO, AT, AU, AZ, BA, BB, BG, BH, BN, BR, BW, BY, BZ, CA, CH, CL, CN, CO, CR, CU, CZ, DE, DJ, DK, DM, DO, DZ, EC, EE, EG, ES, FI, GB, GD, GE, GH, GM, GT, HN, HR, HU, ID, IL, IN, IR, IS, JP, KE, KG, KH, KN, KP, KR, KW, KZ, LA, LC, LK, LR, LS, LU, LY, MA, MD, ME, MG, MK, MN, MW, MX, MY, MZ, NA, NG, NI, NO, NZ, OM, PA, PE, PG, PH, PL, PT, QA, RO, RS, RU, RW, SA, SC, SD, SE, SG, SK, SL, SM, ST, SV, SY, TH, TJ, TM, TN, TR, TT, TZ, UA, UG, US, UZ, VC, VN, ZA, ZM, ZW.
- (84) Designated States (unless otherwise indicated, for every kind of regional protection available): ARIPO (BW, GH, GM, KE, LR, LS, MW, MZ, NA, RW, SD, SL, ST, SZ, TZ, UG, ZM, ZW), Eurasian (AM, AZ, BY, KG, KZ, RU, TJ, TM), European (AL, AT, BE, BG, CH, CY, CZ, DE, DK, EE, ES, FI, FR, GB, GR, HR, HU, IE, IS, IT, LT, LU, LV, MC, MK, MT, NL, NO, PL, PT, RO, RS, SE, SI, SK, SM, TR), OAPI (BF, BJ, CF, CG, CI, CM, GA, GN, GQ, GW, KM, ML, MR, NE, SN, TD, TG).

(54) Title: CAMERA MODULE FOR A MOTOR VEHICLE

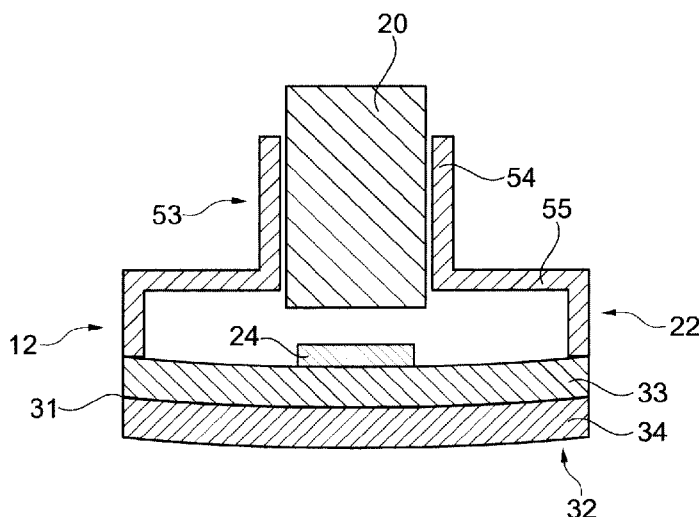

Fig. 3

(57) Abstract: A camera module (12) for a motor vehicle comprises a lens assembly (20), a housing (22) comprising a back plate (32) and a lens holder (53), wherein said back plate (32) carries an image sensor (24) within the housing (22), wherein said lens holder (53) is mounted to said back plate (32) and holds said lens objective (20) such that said image sensor (24) is arranged in or close to an image plane (A) of the lens objective (20). The back plate (32) comprises at least one bi-material element (31) holding said image sensor (24), said bi-material element (31) having at least two layers (33, 34) of materials having significantly different thermal properties and being joined together such that the bi-material element (31) is adapted to bend with changing temperature.



**Published:**

— *with international search report (Art. 21(3))*

## Camera module for a motor vehicle

5 The invention relates to a camera module for a motor vehicle, comprising a lens objective, a housing comprising a back plate and a lens holder, wherein said back plate carries an image sensor within the housing, wherein said lens holder is mounted to said back plate and holds said lens objective such that  
10 said image sensor is arranged in or close to an image plane of the lens objective.

Automotive camera modules are exposed to temperatures varying over a large range, and are required to have excellent imaging  
15 performance over the whole temperature range occurring in practice. Furthermore, automotive camera modules normally do not include an autofocus mechanism for cost reasons. In many fixed-focus automotive camera modules, a major challenge is to retain the focus over the temperature envelope  $T$ . For  
20 low  $f/\#$  lenses, the distance between the image and the sensor must be controlled at a scale of micrometres.

Temperature differences lead to a respective change of the dimensions of the housing of the camera module. For instance,  
25 the height of the housing increases due to thermal expansion with an increase of the housing temperature. Accordingly, a distance between the lens objective, usually attached to a front end of the housing, and the image sensor, usually arranged at a back end of the housing, increases with a temperature  
30 increase, resulting in the sensor moving out of the image plane of the lens objective. Consequently, at high or very low temperatures the image sensor may not detect an image as clear as at moderate temperatures.

Therefore, for fixed focus cameras, there is a need to balance the image plane drift caused by the lens objective at largely varying temperatures; otherwise image sharpness will inevitably decrease under such conditions. Even more, since pixel size of image sensors is constantly being reduced, the image plane drift has to be controlled with increasing precision.

Solutions exist to control the image plane drift by introducing counter-acting mechanical elements in the camera module, so-called "athermalizers". For example, WO 2015/032512 A1 discloses an automotive camera module having a tube holding the lens objective, the tube being tuned to cancel the image plane drift. Although this solution is simple and reliable, the tube is an additional part which causes additional steps in the mounting of the camera module.

The problem underlying the present invention is to provide a fast-to-mount camera module having a simple mechanism to keep the image sensor close to the image plane of the lens objective.

The invention solves this objective with the features of the independent claims. The invention has realized that the thermal drift of the focus plane out of the image sensor plane can be counteracted at the back side of the camera module, namely by providing a bi-material element holding the image sensor and designed to bend with changing temperature. The bending action causes the image sensor to move, and this movement can be designed such that the image sensor, and with it the sensor plane, follows the thermal displacement of the image focus plane.

Preferably, therefore, the bi-material element is designed such that the bending of the bi-material element acts towards keeping the image plane in a predetermined positional relation to the image sensor, most preferably in the sensitive plane of the image sensor. Ideally the bending of the bi-material element holding the image sensor is tuned such that the image focus plane and the sensor plane are coinciding over the whole temperature range existing in automotive applications. Advantageously the bi-material element is designed such that a thermal displacement of the bi-material element is able to compensate a thermal expansion of the lens holder and a shift of the image plane caused by changes of and within the lens objective.

The realization of the invention comprises different preferred aspects which shall be described in the following. Preferably the designing of the bi-material element comprises one or more of:

- choosing the material of the layers to have different suited coefficients of thermal expansion;
- choosing the material of the layers to have suited elastic moduli; and/or
- choosing a suited geometry of the bi-material element, in particular a suited thickness of the layers.

In preferred embodiments under the present invention, the material of one or preferably both of said at least two layers is a metal. In particular, the bi-material element may be a bi-metal strip or plate. In these embodiments, the material of the layers may for example be based on iron, like steel, and/or be based on copper and/or tin, like brass.

In other preferred embodiments under the present invention, the layers are formed by layers of a sandwiched structure, like a PCB structure, comprising a metal layer, for example a copper layer, and a non-metal composite layer, like a glass fibre layer. In such embodiments, the bending properties of the plate may preferably be tuned by one or more of

- adjusting the copper coverage in the copper layer of the sandwiched structure, for example in the form of a square grid;
- 10 - providing slits in at least one of said plate layers to mechanically decouple from the stiff lens holder;
- providing an inhomogeneous pattern in said metal layer, in particular in said copper layer, wherein the inhomogeneous pattern may preferably comprise stripes in a preferred direction, a circular pattern, or combinations thereof.

The invention solves the above mentioned objective also with a camera module of the same kind, where instead of a bi-material element in the back plate, the back plate and the lens holder are made of materials having thermal properties and geometries and being connected together such that the back plate is adapted to bend with changing temperature. In this embodiment, the material, thickness and geometries of the back plate and the lens holder are combined to achieve the bi-material effect. Many preferred features described above with respect to the bi-material element in the back plate also apply for this embodiment in a corresponding manner. In particular, the back plate is designed and connected to the lens holder in such a manner such that the bending of the back plate acts towards keeping the image plane in a predetermined positional relation to the image sensor.

In the following the invention shall be illustrated on the basis of preferred embodiments with reference to the accompanying drawings, wherein:

5 Fig. 1 schematically shows a vision system comprising the inventive camera module;

Figs. 2, 3 schematically show an embodiment of the inventive camera module;

10

Fig. 4 schematically shows an inventive camera module in another embodiment;

Fig. 5 shows a schematic cross-sectional view of a lens objective for use in an inventive camera module; and

15

Fig. 6 schematically shows an inventive camera module in a further embodiment.

20 In Fig. 1 a vision system 10 is shown which is mounted in a motor vehicle (not shown) and comprises an imaging apparatus 11 for acquiring images of a region surrounding the motor vehicle, for example a region in front of the motor vehicle. The imaging apparatus 11 comprises one or more camera modules 12.

25 The camera module 12 preferably operates in the visible wavelength region. In an alternative embodiment, the camera module 12 operates in the infrared wavelength region, where infrared covers near IR with wavelengths below 5 microns and/or far IR with wavelengths beyond 5 microns. In one embodiment the imaging

30 apparatus 11 comprises a plurality of camera modules 12 in particular forming a stereo imaging apparatus 11. Alternatively only camera module 12 forming a mono imaging apparatus 11 can be used.

The image data from the imaging apparatus 11 are provided to an electronic processing device 14 where image and data processing is carried out by corresponding software. In particular, the image and data processing in the processing device 14 comprises the following functions: identification and classification of possible objects surrounding the motor vehicle, such as pedestrians, other vehicles, bicyclists or large animals; tracking over time the position of identified object candidates in the recorded images; calculation of a collision probability between the vehicle and a detected object; and/or activation or control of at least one driver assistance device 18 depending on the result of the object detection and tracking processing and/or said collision probability calculation. The driver assistance device 18 may comprise a display device for displaying information relating to a detected object; a warning device adapted to provide a collision warning to the driver by suitable optical, acoustical and/or haptical warning signals; one or more restraint systems such as occupant airbags or safety belt tensioners, pedestrian airbags, hood lifters and the like; and/or dynamic vehicle control systems such as brakes or steering device. The processing device 14 expediently has access to a memory device 25.

The data processing device 14 is preferably a digital device which is programmed or programmable and preferably comprises a microprocessor, micro-controller, digital signal processor (DSP) or a System-On-Chip (SoC) device. The data processing device 14 and the memory device 25 are preferably realised in an on-board electronic control unit (ECU) and may be connected to the imaging apparatus 11 via a separate cable or a vehicle data bus. In another embodiment the ECU and one or more of the imaging devices 12 can be integrated into a single unit, where

a one box solution including the ECU and all imaging devices 12 can be preferred. All steps from imaging, image processing to possible activation or control of driver assistance device 18 are performed automatically and continuously during driving  
5 in real time.

In Fig. 2 an embodiment of the inventive camera module 12 is schematically shown. The camera module 12 comprises a lens objective 20, a housing 22 and an image sensor 24. The housing  
10 22 comprises a lens holder 53 and a back plate 32 holding the image sensor 24. The housing 22 is basically closed in a light tight manner except for an opening 28 at a front end. The lens holder 53 comprises a tubular part 54 holding the lens objective 20 and a base part 55 adapted to connect the lens holder  
15 53 to the back plate 32. The tubular part 54 is preferably cylindrical and extends parallel to the optical axis of the lens objective 20.

Radiation or light from an image incidenting through the opening 28 is transmitted through the lens objective 20 held by  
20 the lens holder 53. The lens objective 20 focuses the image in the image plane A of the lens objective 20. The lens objective 20 and the sensitive plane of the image sensor 24 are arranged apart from each other with a predetermined distance  $d_1$ , which  
25 ideally corresponds to the back focal distance of the lens objective 20 such that the image focus lies in the sensitive plane of the image sensor 24.

The image sensor 24 is preferably a two-dimensional image sensor, in particular an optical sensor having maximum sensitivity preferably in the visible wavelength region, and is adapted  
30 to convert incident light into an electrical signal containing image information of the image to be detected. As mentioned

above, the image sensor 24 is advantageously arranged within the housing 22 in or close to the image plane A of the lens objective 20.

5 Preferably the lens holder 53 is made of a metal or a metal alloy, for example a zink alloy. In another embodiment, the lens holder 53 may be made of a polymer material, for example Polyphenylene sulphide (PPS). Further preferably the lens holder 53 is made of reinforced plastics, in particular glass  
10 fiber and/or mineral powder reinforced plastics. A very preferred material for the lens holder 53 is PPS GM65, i.e. PPS with 65% glass fiber and mineral powder reinforcement.

The temperature dependent distance  $a(T)$  between the image  
15 plane A and the sensitive surface of the sensor 24 is determined by two parameters, see Figure 2. The first is the temperature dependent distance  $d1(T)$  between the lens objective 20 and the sensitive surface of the sensor 24. The second is the distance  $d2(T)$  between the lens objective 20 and the image  
20 plane A which varies over temperature due to mechanical displacements in the lens objective 20, change in refractive index of the optical elements or lenses in the lens objective 20, dimensional changes within the lens objective 20, etc. The image position A relative to the sensor 24 is then given by  
25  $a(T) = d1(T) - d2(T)$ . Ideally, the image plane shall always coincide with the sensor surface, i.e.  $a(T) = 0$ , such that  $d1(T) = d2(T)$ .

In order to achieve this, the image sensor 24 is mounted on a  
30 bi-material element 31 which is preferably planar and has the form of a plate or strip. In particular, the bi-material element 31 can form the back plate 32, be part of the back plate 32 or be mounted on the back plate 32. The image sensor 24 is

preferably mounted in the center of the bi-material element 31 in a longitudinal direction, as shown in Figures 2 to 4. The bi-material element 31 comprises at least two layers 33, 34 made of different materials having significantly different coefficients of thermal expansion (CTE) and connected to each other in a manner (for example along opposing edges of the bi-material element 31) such that the bi-material element 31 bends which changing temperature.

In one embodiment, the layers 33, 34 may be made of metal, for example an iron based layer 33 like steel, and a copper and/or tin based layer 34 like brass. In another embodiment, the layers 33, 34 may be the layers of a sandwiched PCB structure, in particular a copper layer and a glass fiber layer.

The materials of the plate layers 33, 34 are duly chosen such that the above equation  $d_1(T)=d_2(T)$  is fulfilled over the temperature range occurring in the operation of a motor vehicle.

In the embodiment of Figures 2 and Figure 3 the plate 33 of material having the lower CTE is facing towards the lens objective 20 and carries the image sensor 24, whereas the plate 34 of material having the higher CTE is arranged at the outer side of the camera module 23 facing away from the lens objective 20. In such embodiments the bi-material element 31 bends outwards in a convex manner, i.e. away from the lens objective 20, with rising temperature. For example, Figure 2 shows a planar state of the bi-material element 31 at a reference temperature, and Figure 3 shows a bent state of the bi-material element 31 at a temperature significantly higher than the reference temperature. Since the lens holder 53 expands with rising temperature (no materials are known which contract with rising temperature), this embodiment may be beneficial in case where downward movement of the image plane A with rising tem-

perature caused by effects in the lens objective 20 dominates over contraction of the lens holder 53.

In the embodiment of Figure 4 the plate 33 of material having the lower CTE is arranged at the outer side of the camera module 23 facing away from the lens objective 20, whereas the plate 34 of material having the higher CTE is facing towards the lens objective 20 and carries the image sensor 24. In other words, the arrangement of the layers 33, 34 is vice versa as compared to Figures 2 and 3. In such embodiments the bi-material element 31 bends inwards in a concave manner, i.e. towards the lens objective 20, with rising temperature. This embodiment may be beneficial in case the expansion of the lens holder 53 is dominating over the movement of the image plane A caused by effects in the lens objective 20.

The lens objective 20 comprises a lens barrel 63 and one or more lenses 64 to 69 held inside the lens barrel 63 and spaced from each other using ring shaped spacers 70, see Figure 5. The lens barrel 63 and the spacers 70 are preferably made of metal, in particular brass. The lenses 64 to 69 may comprise convex lenses 65, 66, 68, 69 and concave lenses 64, 67. The outer shape of the lens barrel 63 is generally cylindrical and closely fits the inner cylindrical shape of the tubular part 24 such that the lens objective 20 is closely guided in the tubular part 24.

There is no requirement that a practical embodiment of the invention comprises a state with plane or even bi-material element 31 as shown in Figure 2. In particular, a practical embodiment of the invention may be designed such that the bi-material element 31 changes between a less convex bent state and largely convex bent state, or between a less concave bent

state and largely concave bent state. That is, the bi-material element 31 may be bent in one direction over the whole temperature range occurring in automobile operation.

5 Figure 6 shows an embodiment where the back plate 32 is made of a material, form and thickness which leads to a bending of the back plate 32 here towards the lens objective 20 when the temperature rises, such that the image sensor 24 mounted on the back plate 32 moves towards the lens objective 20 with  
10 rising temperature. In particular, the back plate 32 may be made of a material having significantly different thermal properties, in particular a higher CTE, as compared to the material of the lens holder 53. Therefore, in this embodiment, the desired bi-material effect is achieved through the connec-  
15 tion of the back plate 32 to the lens holder 53, whereas no thermal bending is required in the back plate 32 on its own, i.e. when disconnected from the lens holder 53.

## Claims:

1. A camera module (12) for a motor vehicle, comprising a lens objective (20), a housing (22) comprising a back plate (32) and a lens holder (53), wherein said back  
5 plate (32) carries an image sensor (24) within the housing (22), wherein said lens holder (53) is mounted to said back plate (32) and holds said lens objective (20) such that said image sensor (24) is arranged in or close  
10 to an image plane (A) of the lens objective (20), characterized in that the back plate (32) comprises at least one bi-material element (31) holding said image sensor (24), said bi-material element (31) having at least two layers (33, 34) of materials having significantly different  
15 thermal properties and being connected together such that the bi-material element (31) is adapted to bend with changing temperature.
2. The camera module (12) as claimed in claim 1, characterized  
20 in that the bi-material element (31) is designed such that the bending of the bi-material element (31) acts towards keeping the image plane (A) in a predetermined positional relation to the image sensor (24).
- 25 3. The camera module (12) as claimed in claim 2, characterized in that the designing of the bi-material element (31) comprises choosing the material of the layers (33, 34) to have different suited coefficients of thermal expansion.
- 30 4. The camera module (12) as claimed in claims 2 or 3, characterized in that the designing of the bi-material element (31) comprises choosing the material of the layers

(33, 34) to have suited elastic moduli.

5. The camera module (12) as claimed in any one of claims 2 to 4, characterized in that the designing of the bi-material element (31) comprises choosing a suited geometry of the bi-material element (31).  
5
6. The camera module (12) as claimed in claim 5, characterized in that the designing of the bi-material element (31) comprises choosing a suited thickness of said layers (33, 34).  
10
7. The camera module (12) as claimed in any one of the preceding claims, characterized in that said bi-material element (31) is designed to bend away from the lens objective (20) with rising temperature.  
15
8. The camera module (12) as claimed in any one of the preceding claims, characterized in that bi-material element (31) is adapted to bend towards the lens objective (20) with rising temperature.  
20
9. The camera module (12) as claimed in any one of the preceding claims, characterized in that the material of one or preferably both of said at least two layers (33, 34) is a metal.  
25
10. The camera module (12) as claimed in any one of the preceding, characterized in that the layers (33, 34) are formed by layers of a sandwiched structure, like a PCB structure, comprising a metal layer, for example a copper layer, and a non-metal composite layer, like a glass  
30

fiber layer.

11. The camera module (12) as claimed in claim 10, characterized in that the bending properties of the bi-material element (31) are tuned by adjusting the copper coverage in the copper layer of the sandwiched structure, for example in the form of a square grid.
12. The camera module (12) as claimed in claim 10 or 11, characterized in that the bending properties of the bi-material element (31) are tuned by providing slits in at least one of said layers (33, 34) to mechanically decouple from the lens holder (53).
13. The camera module (12) as claimed in any one of claims 10 to 12, characterized in that the bending properties of the bi-material element (31) are tuned by providing an inhomogeneous pattern in said metal layer, in particular in said copper layer, wherein preferably said inhomogeneous pattern comprises stripes in a preferred direction, a circular pattern, or combinations thereof.
14. The camera module (12) as claimed in any one of the preceding claims, characterized in that the bi-material element (31) is designed such that a thermal displacement of the bi-material element (31) is able to compensate a thermal expansion of the lens holder (53) and a shift of the image plane caused by changes of and within the lens objective (20).
15. A camera module (12) for a motor vehicle, comprising a lens objective (20), a housing (22) comprising a back plate (32) and a lens holder (53), wherein said back

plate (32) carries an image sensor (24) within the housing (22), wherein said lens holder (53) is mounted to said back plate (32) and holds said lens objective (20) such that said image sensor (24) is arranged in or close  
5 to an image plane (A) of the lens objective (20), characterized in that the back plate (32) and the lens holder (53) have thermal properties and geometries and being connected together such that the back plate (32) is adapted to bend with changing temperature.

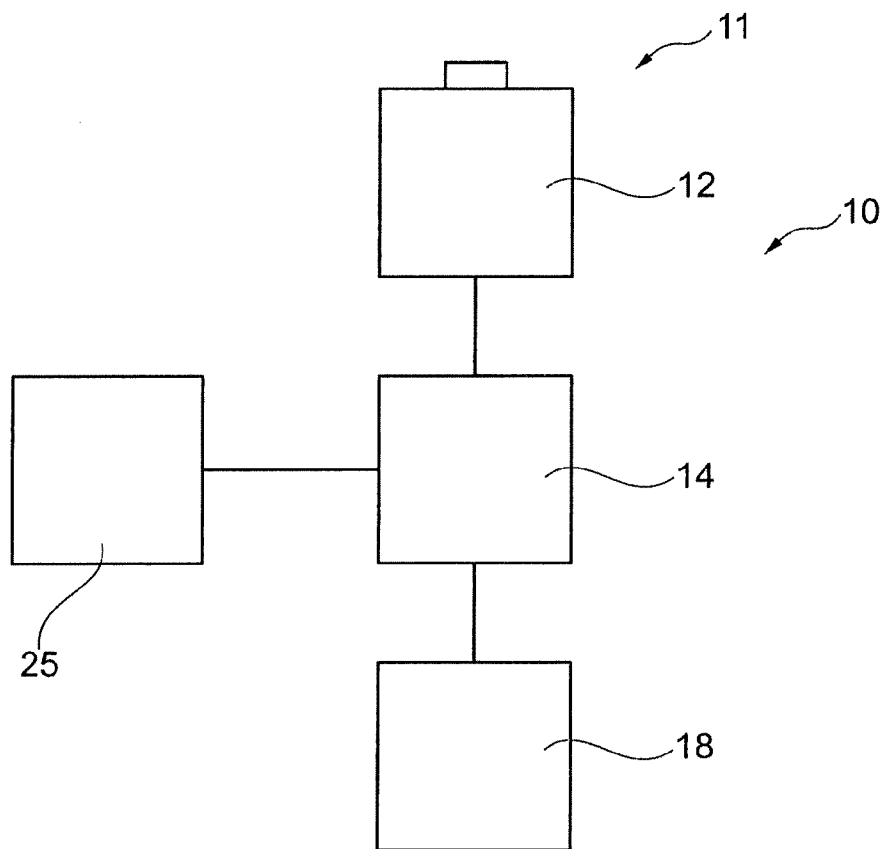
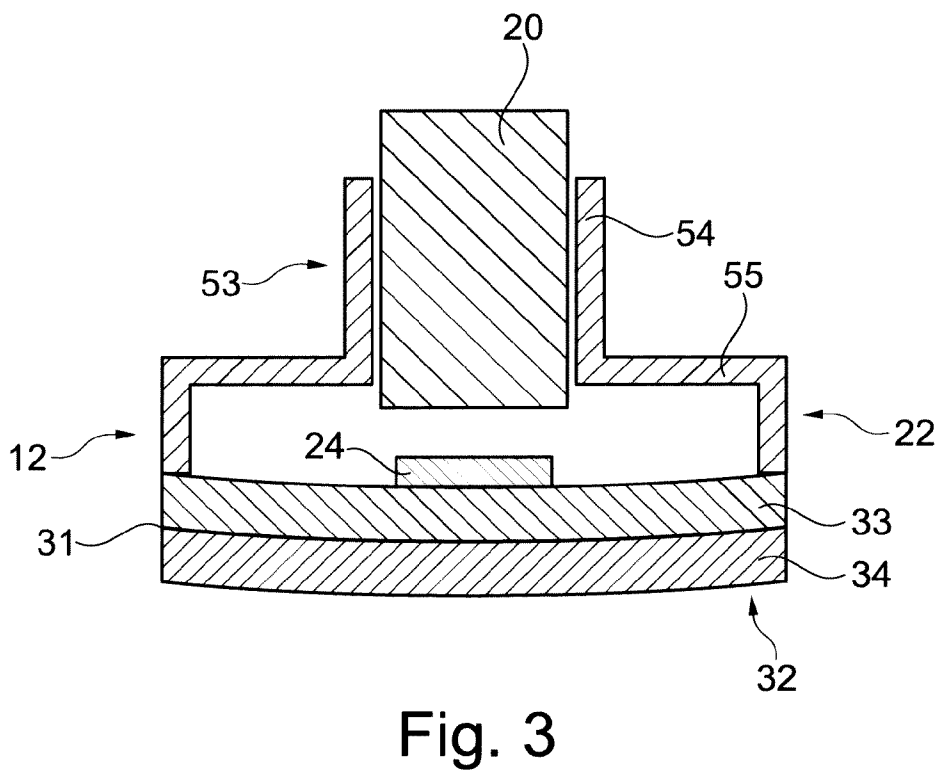
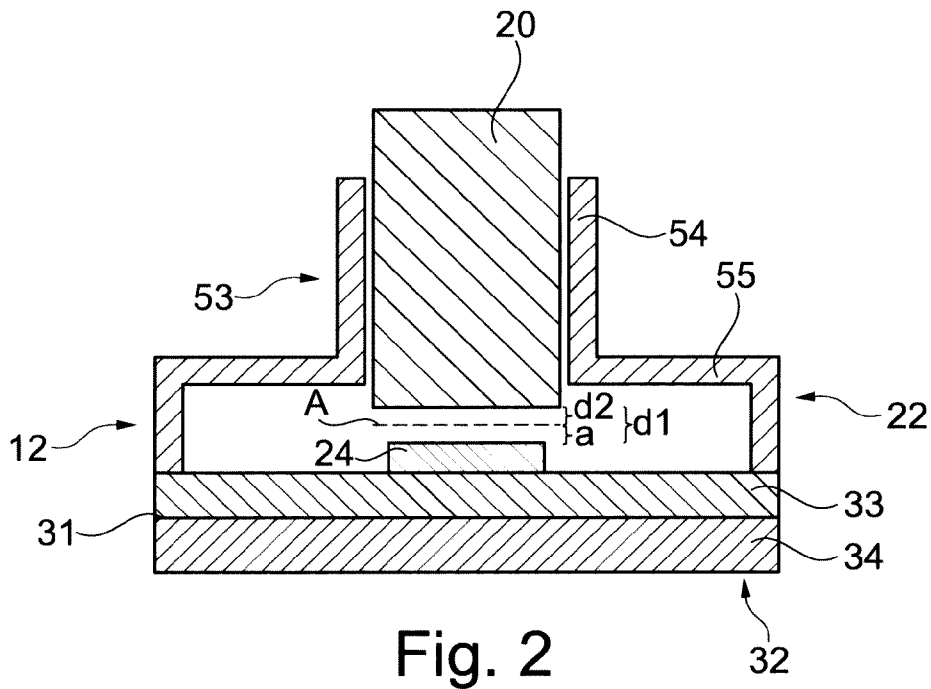

Fig. 1



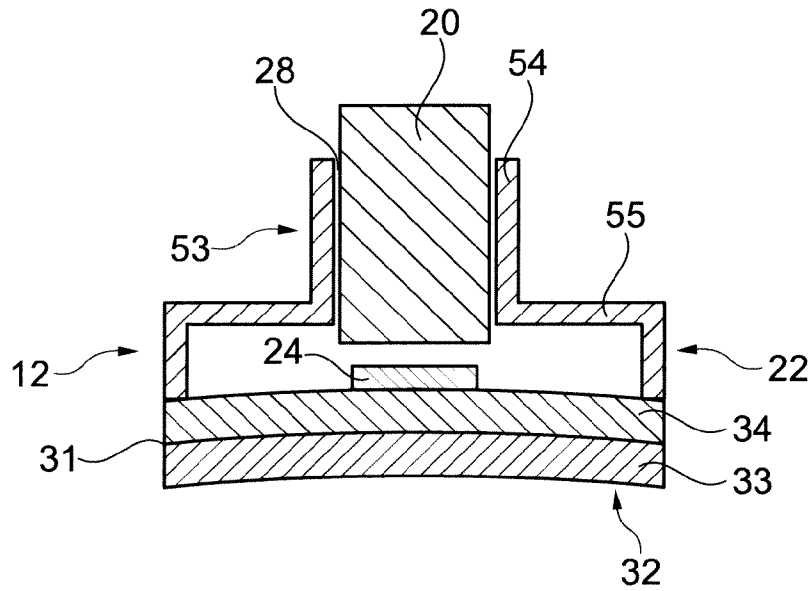

Fig. 4

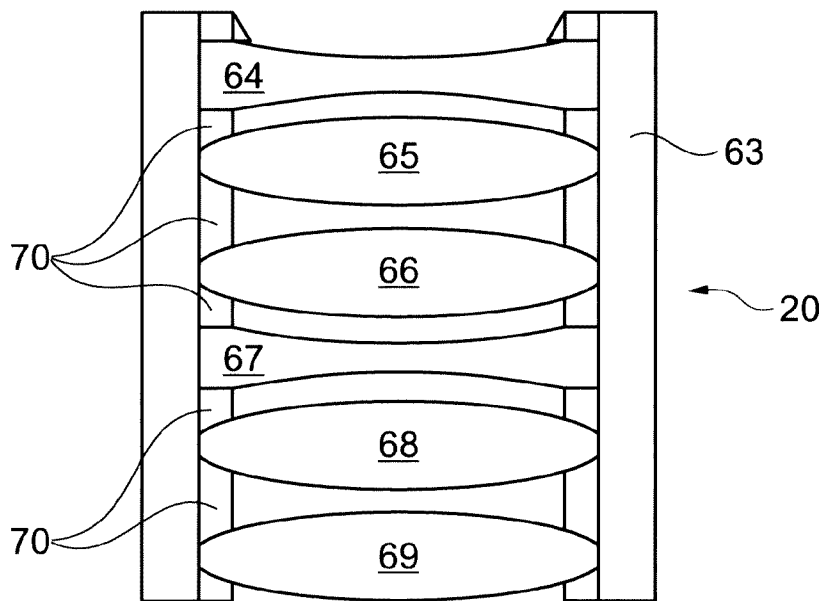

Fig. 5

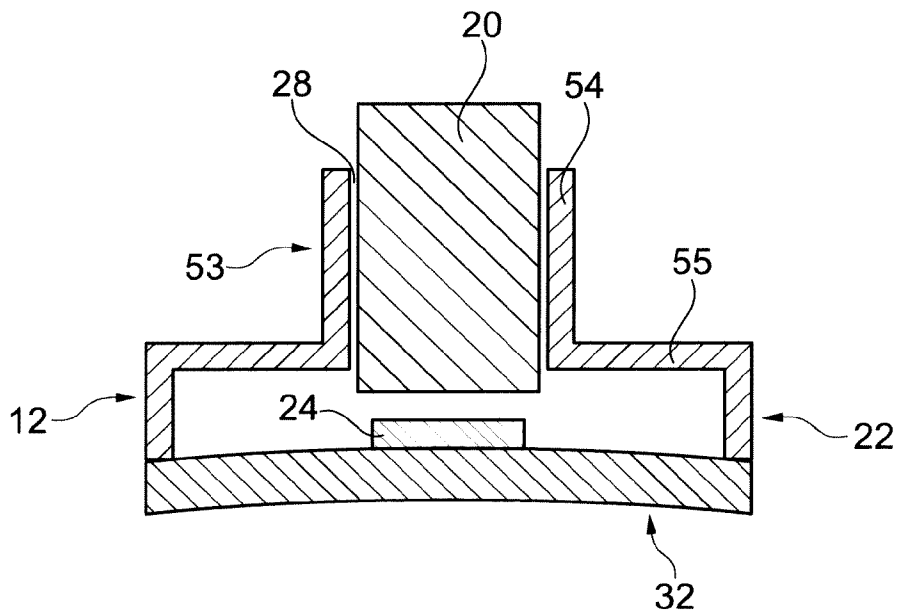

Fig. 6

**INTERNATIONAL SEARCH REPORT**

International application No  
PCT/EP2017/061108

A. CLASSIFICATION OF SUBJECT MATTER  
INV. G02B7/00 G02B7/02  
ADD.  
According to International Patent Classification (IPC) or to both national classification and IPC

B. FIELDS SEARCHED  
Minimum documentation searched (classification system followed by classification symbols)  
G02B

Documentation searched other than minimum documentation to the extent that such documents are included in the fields searched

Electronic data base consulted during the international search (name of data base and, where practicable, search terms used)  
EPO-Internal, WPI Data

C. DOCUMENTS CONSIDERED TO BE RELEVANT

Category*	Citation of document, with indication, where appropriate, of the relevant passages	Relevant to claim No.
Y	US 2008/278833 A1 (YUAN KUN-I [TW]) 13 November 2008 (2008-11-13) paragraphs [0004], [0007], [0015], [0018], [0019]; figures 1-3 -----	1-10, 12-15
Y	JP 2004 147188 A (FUJI PHOTO FILM CO LTD) 20 May 2004 (2004-05-20) claims 1,2 -----	1-10, 12-15
X A	US 5 614 763 A (WOMACK GARY L [US]) 25 March 1997 (1997-03-25) column 4, line 60 to column 5, line 11 column 5, lines 33-36 and 45; column 1 -----	1-10,14, 15 11

Further documents are listed in the continuation of Box C.

See patent family annex.

\* Special categories of cited documents :

<p>"A" document defining the general state of the art which is not considered to be of particular relevance</p> <p>"E" earlier application or patent but published on or after the international filing date</p> <p>"L" document which may throw doubts on priority claim(s) or which is cited to establish the publication date of another citation or other special reason (as specified)</p> <p>"O" document referring to an oral disclosure, use, exhibition or other means</p> <p>"P" document published prior to the international filing date but later than the priority date claimed</p>	<p>"T" later document published after the international filing date or priority date and not in conflict with the application but cited to understand the principle or theory underlying the invention</p> <p>"X" document of particular relevance; the claimed invention cannot be considered novel or cannot be considered to involve an inventive step when the document is taken alone</p> <p>"Y" document of particular relevance; the claimed invention cannot be considered to involve an inventive step when the document is combined with one or more other such documents, such combination being obvious to a person skilled in the art</p> <p>"&amp;" document member of the same patent family</p>
---	---

Date of the actual completion of the international search <b>1 June 2017</b>	Date of mailing of the international search report <b>13/06/2017</b>
---	---

Name and mailing address of the ISA/ European Patent Office, P.B. 5818 Patentlaan 2 NL - 2280 HV Rijswijk Tel. (+31-70) 340-2040, Fax: (+31-70) 340-3016	Authorized officer <b>Albero Silvestre, J</b>
--	--

# INTERNATIONAL SEARCH REPORT

Information on patent family members

International application No

PCT/EP2017/061108

Patent document cited in search report	Publication date	Patent family member(s)	Publication date
US 2008278833	A1	CN 101303442 A	12-11-2008
		US 2008278833 A1	13-11-2008
-----			
JP 2004147188	A	NONE	
-----			
US 5614763	A	NONE	
-----			