

(12) STANDARD PATENT
(19) AUSTRALIAN PATENT OFFICE

(11) Application No. **AU 2005201241 B2**

- (54) Title
Water heater having raw fuel jet pilot and associated burner clogging detection apparatus
- (51) International Patent Classification(s)
F24H 1/34 (2006.01) **F23D 14/20** (2006.01)
- (21) Application No: **2005201241** (22) Date of Filing: **2005.03.22**
- (30) Priority Data
- (31) Number (32) Date (33) Country
10/933,776 **2004.09.03** **US**
- (43) Publication Date: **2006.03.23**
(43) Publication Journal Date: **2006.03.23**
(44) Accepted Journal Date: **2008.04.17**
- (71) Applicant(s)
Rheem Manufacturing Company
- (72) Inventor(s)
Peart, Jacob A.
- (74) Agent / Attorney
Spruson & Ferguson, Level 35 St Martins Tower 31 Market Street, Sydney, NSW, 2000
- (56) Related Art
US 6540504

WATER HEATER HAVING RAW FUEL JET PILOT AND ASSOCIATED BURNER CLOGGING DETECTION APPARATUS

ABSTRACT OF THE DISCLOSURE

5 A radiant gas burner (28) within the combustion chamber (16) of a water heater (10) has a pilot flame (50) created using a raw fuel jet that impinges on an interior surface portion (54a) of a flame holding outer burner wall portion (54), representatively of a metal wire mesh material (54), and is mixed within the burner (28) with combustion air (36) delivered thereto from outside the combustion chamber (16). The resulting fuel/air
10 mixture (34a, 36) passes outwardly through the impinged upon mesh wall portion (54), which functions as a pilot flame stabilizing structure, and is ignited to form a pilot flame (50) on the exterior of the burner body. A thermocouple portion (66) of a clogging detection system (64) senses a change in the pilot flame shape caused by particulate clogging of the metal mesh material (54) and responsively terminates further gas supply
15 to the water heater (10).

2005201241 22 Mar 2005

S&F Ref: 712641

AUSTRALIA

PATENTS ACT 1990

COMPLETE SPECIFICATION

FOR A STANDARD PATENT

Name and Address of Applicant :	Rheem Manufacturing Company, of 405 Lexington Avenue 22nd Floor, New York, New York, 10174, United States of America
Actual Inventor(s):	Jacob A. Peart
Address for Service:	Spruson & Ferguson St Martins Tower Level 35 31 Market Street Sydney NSW 2000 (CCN 3710000177)
Invention Title:	Water heater having raw fuel jet pilot and associated burner clogging detection apparatus

The following statement is a full description of this invention, including the best method of performing it known to me/us:-

**WATER HEATER HAVING RAW FUEL JET PILOT AND
ASSOCIATED BURNER CLOGGING DETECTION APPARATUS**

BACKGROUND OF THE INVENTION

The present invention generally relates to fuel fired heating apparatus and, in a representatively illustrated embodiment thereof, more particularly provides a fuel-fired water heater having incorporated therein a specially designed raw fuel jet pilot structure and associated burner clogging detection apparatus.

15 Despite continuing improvements in the fuel efficiency of and reduction in undesirable operating emissions therefrom, modern fuel-fired waters still have various operational characteristics which are less than entirely satisfactory. For example, the burner pilots in most if not all conventional fuel-fired water heaters draw their combustion air from the area within the combustion chamber surrounding the pilot burner and its
20 associated main burner. In some water heater combustion chamber configurations this air surrounding the pilot is diluted with exhaust gases. This undesirably reduces the amount of available oxygen for proper pilot combustion. With respect to this pilot-related problem, the water heater designer is faced with two conflicting design criteria - the need for the
25 pilot to be close to the main burner for proper ignition thereof, and the need for the pilot to be near a clean combustion air source for proper pilot combustion.

30 Another design challenge associated with modern fuel-fired water heaters is that they typically operate in locations that are not regularly cleaned (for example, in attics, closets, basements, sheds, etc.). Due to the presence of various types of contaminants present in such locations,

which tend to clog various components of the water heater such as its burner, the water heater must either be able to operate reliably and safely throughout its life, or, in the case of extreme contamination from clogging materials such as lint, dust and oil, needs to be designed to safely shut itself down before producing undesirably high levels of carbon monoxide caused by clogging of various components of the water heater.

As can be seen from the foregoing, a need exists for a fuel-fired water heater having improvements in the above-described areas.

It is the object of the present invention to overcome or ameliorate one or more of the disadvantages of the prior art, or at least to provide a useful alternative.

SUMMARY OF THE INVENTION

In a first aspect, the present invention provides a combustion apparatus comprising:

a wall structure defining a combustion chamber;

a main fuel burner disposed within said combustion chamber;

a pilot flame stabilizing structure disposed within said combustion chamber;

fuel delivery apparatus operable to receive fuel from a source thereof and discharge the received fuel in the form of a fuel jet that impinges against said pilot flame stabilizing structure; and

air delivery apparatus through which combustion air from outside said combustion chamber is flowable to the discharged fuel jet to form therewith a fuel/air mixture ignitable to create a pilot flame extending outwardly from said pilot flame stabilizing structure.

In a second aspect, the present invention provides a method of creating hot combustion products in the combustion chamber of a fuel-fired heating appliance, said method comprising the steps of:

positioning a pilot flame stabilizing structure within said combustion chamber;

positioning a main fuel burner within said combustion chamber;

creating within said combustion chamber a fuel jet which impinges upon said pilot flame stabilizing structure;

mixing air from outside said combustion chamber with said fuel jet to form therewith a fuel/air mixture; and

igniting said fuel/air mixture to create a pilot flame extending outwardly from said pilot flame stabilizing structure and useable to ignite a fuel/air mixture subsequently supplied to said main fuel burner.

In a third aspect, the present invention provides a fuel-fired heating appliance comprising:

a combustion chamber thermally communicatable with a fluid to be heated;

a main burner disposed within said combustion chamber; and

5 a pilot burner structure disposed within said combustion chamber for igniting said main burner and including:

a flame stabilizing structure disposed within said combustion structure;

10 fuel delivery apparatus operable to receive fuel from a source thereof and discharge the received fuel in the form of a fuel jet that impinges against said flame stabilizing structure; and

air delivery apparatus through which combustion air from outside said combustion chamber is flowable through an enclosed flow path to adjacent the discharged fuel jet to form therewith a fuel/air mixture ignitable to create a pilot flame extending outwardly from said flame stabilizing structure.

15 In a fourth aspect, the present invention provides a fuel combustion apparatus comprising:

a hollow burner body having an outer wall portion with fuel/air discharge openings therein;

20 a fuel delivery tube extending into the interior of said burner body, said fuel delivery tube being operative to receive pressurized fuel from a source thereof and discharge from an opening therein a fuel jet which impinges against the interior surface of said outer wall portion; and

25 an air delivery conduit extending into the interior of said burner body and operative to deliver combustion air from a source thereof to the discharged fuel jet to form therewith a fuel/air mixture passing outwardly through discharge openings in a section of said outer wall portion and being ignitable to form a pilot flame extending outwardly from said outer wall portion.

30 In carrying out principles of the present invention, in accordance with a representatively illustrated embodiment thereof, a fuel-fired heating appliance is provided with specially designed combustion apparatus illustratively comprising a wall structure defining a combustion chamber; a flame stabilizing structure disposed within the combustion chamber; fuel delivery apparatus operable to receive fuel from a source thereof and discharge the receive fuel in the form of a fuel jet that impinges upon the flame stabilizing structure; and air delivery apparatus through which combustion air from

outside the combustion chamber is flowable to the discharged fuel jet to form therewith a fuel/air mixture ignitable to create a flame extending outwardly from the flame stabilizing structure.

5 The heating appliance is illustratively a gas-fired water heater, but could alternatively be another type of fuel-fired heating appliance such as, for example, a boiler or an air heating furnace. In the depicted water heater the combustion apparatus also includes a main burner disposed in the combustion chamber, the main burner having a hollow body with an outer wall having fuel/air discharge openings therein. The pilot flame fuel jet impinges against an interior surface of this outer wall, is mixed with the
10 incoming combustion air within the main burner, and passes outwardly through the main burner discharge openings whereupon it is suitably ignited to form the pilot flame on the exterior surface of the outer wall, part of which defines the aforementioned flame stabilizing structure impinged upon by the discharged fuel jet.

In the illustrated water heater embodiment, the main burner is a radiant fuel
15 burner with the outer wall portion thereof being a flame holding wall formed from a metal mesh material. However, the invention is not limited to a combustion system employing a radiant burner - other types of main burners may be utilized without departing from principles of the present invention, and apertured outer burner walls of other types, such as ceramic, porous, woven materials, etc., may be alternatively utilized if desired.

20 According to another embodiment of the invention, the fuel-fired heating appliance is also provided with a clogging detection system which shuts down the burner, preventing the generation of either of its main and pilot flames, in response to sensing a clogging of the burner caused, for example, by particulate matter passing through the burner and plugging up its fuel/air discharge openings. In an illustrated embodiment
25 thereof, this clogging detection system functions to sense burner clogging, by detecting an undersirable change in the shape of the pilot flame, and responsively closing a fuel valve controlling fuel flow to the burner and its associated pilot structure. Representatively, this sensing function of the clogging detection system is performed by a thermocouple positioned to be impinged upon by the pilot flame and operatively coupled to the fuel
30 valve.

In accordance with a further embodiment of the invention, a section of the apertured outer burner wall containing the portion thereof interiorly impinged upon by the pilot flame is more susceptible to clogging than the balance of the apertured outer wall of the burner, thereby increasing the sensitivity of the clogging detection system. In the

illustrated mesh outer flame-holding wall embodiment, the mesh spacing of the outer wall section interiorly impinged upon by the pilot flame is smaller than the mesh spacing of the balance of the outer wall.

BRIEF DESCRIPTION OF THE DRAWINGS

5 A preferred embodiment of the present invention will now be described, by way of an example only, with reference to the accompanying drawings, in which:

FIG. 1 is a schematic cross-sectional view through a representative fuel-fired water heater embodying principles of the present invention;

10 FIG. 2 is an enlarged scale schematic side elevational view of a raw fuel jet pilot portion of the water heater;

FIG. 3 is a schematic, partially sectioned side elevational view of a burner portion of the water heater incorporating therein the raw fuel jet pilot and an associated burner clogging detection system embodying principles of the present invention;

15 FIGS. 4 and 5 are enlarged scale schematic cross-sectional views through a flame-holding mesh wall of the FIG. 3 burner portion illustrating the operation of the burner clogging detection system; and

FIG. 6 is a schematic top plan view of part of the burner portion taken along line 6-6 of FIG. 4.

DETAILED DESCRIPTION

20 Schematically depicted in FIG. 1 is a fuel-fired heating appliance 10 which is representatively a gas-fired water heater, but which could alternatively be another type of fuel-fired heating appliance, such as, for example, a boiler or an air heating furnace, without departing from principles of the present invention. Water heater 10 has the usual insulated metal tank 12 adapted to hold a quantity of pressurized water 14 to be heated,
25 and a combustion chamber 16 operatively disposed beneath a lower end wall 18 of the tank 12. A flue pipe 20 communicates with the combustion chamber 16 and extends upwardly therefrom through the

water 14, passing upwardly through the upper end 22 of the tank 12. A cold water inlet pipe 24 and a hot water outlet pipe 26 are positioned on the upper end 22 of the tank 12 and communicate with the water 14 therein.

The water 14 in the tank 12 is heated by specially designed fuel burner apparatus 28 operatively disposed in the combustion chamber 16 and embodying principles of the present invention. As schematically depicted in FIG. 1, the burner apparatus 28 includes main and pilot burner portions 30,32 which are supplied with fuel 34 and primary combustion air 36 from outside the combustion chamber 16 in a manner subsequently described herein. During firing thereof the burner apparatus 28 creates hot combustion products 38 that flow upwardly through the flue 20 which transfers combustion heat therethrough to the water 14 to maintain it at a predetermined heated temperature.

15 The pressurized water 14, from a source thereof, is initially flowed into the tank 12 through the cold water inlet pipe 24 and heated as described above. As needed, the pressurized heated water 14 may be supplied to plumbing fixtures, such as sinks, showers, dishwashers and the like, via the hot water outlet pipe 26. Hot water discharged from outlet
20 pipe 26 is automatically replaced with cold water flowed inwardly through inlet pipe 24 into the tank 12.

Pilot portion 32 of the overall fuel burner apparatus 28 is of a unique raw fuel jet construction and, from a conceptual standpoint, operates as schematically depicted in FIG. 2. Pilot portion 32, as previously mentioned,
25 is disposed within the combustion chamber 16 and includes a fuel delivery tube 40 and an air delivery conduit 42, each of which extends into the combustion chamber 16 from exterior thereto. Fuel delivery tube 40 has an outlet opening 44 that underlies and faces a flame stabilization structure 46, which may representatively be a rod, wire or the like,
30 positioned adjacent a suitable pilot ignition structure 48.

During operation of the pilot burner portion 32, a raw jet 34a of pressurized fuel 34 being flowed inwardly through the tube 40 is discharged from the outlet opening 44 onto the flame stabilizing structure 46. Raw fuel jet 34a, by aspiration, draws combustion air 36 from outside the combustion chamber 16 inwardly through the conduit 42 and causes it to mix with the fuel jet 34a for impingement therewith against the fuel stabilizing structure 46. This fuel/air mixture, when ignited by the pilot ignition structure 48, forms a stabilized pilot flame 50 on the downstream side (i.e., the upper side as viewed in FIG. 2) of the stabilizing structure 46.

1 In this manner, conceptually embodying principles of the present invention, a stabilized pilot flame is created and maintained within the combustion chamber utilizing a raw fuel jet and primary combustion being delivered to the pilot burner portion essentially entirely from outside of the combustion chamber.

15 Schematically depicted in FIG. 3 is a representative structural embodiment of the fuel burner apparatus 28 operatively disposed within the combustion chamber 16. The main burner portion 30 of the fuel burner apparatus 28 is representatively a radiant fuel burner having a hollow body 52 with a flame holding upper side wall portion 54

20 illustratively formed from a metal wire mesh material. Alternatively, the flame holding wall portion 54 could be from another material having fuel/air discharge openings therein such as, for example, a ported wall structure, a porous ceramic wall construction, etc., and is not limited to the representatively illustrated metal wire mesh construction.

25 Extending inwardly through an inlet end wall portion 56 of the hollow main burner body 52 are the pilot burner fuel delivery tube 40, the air delivery conduit 42, and a main burner fuel delivery tube 58. The fuel delivery tube 40 has a side wall discharge port 60 (providing the previously described function of the tube outlet opening 44 conceptually illustrated

30 in FIG. 2) positioned adjacent a closed inner end 62 of the tube 40 and in a

downwardly spaced, facing relationship with an interior side surface portion of the metal wire mesh side wall portion 54 of the main burner body 52 adjacent its inlet end wall portion 56. While the main burner portion is representatively a radiant fuel burner, it will be readily appreciated by those of ordinary skill in this particular art that other types of main burners may be utilized without departing from principles of the present invention.

During operation of the pilot burner portion 32 of the fuel burner apparatus 28, the raw fuel jet 34a is upwardly discharged from the fuel tube side wall discharge port 60, and is mixed within the main burner body 30 with combustion air 36 (from outside the combustion chamber 16) flowed into the burner body 30 via the air delivery conduit 42. The resulting fuel/air mixture 34a,36 impinges on an interior side surface of a portion 54a of the metal mesh side wall 54 (see FIG. 4), which defines the
15
16
17
18
19
20
21
22
23
24
25
26
27
28
29
30
31
32
33
34
35
36
37
38
39
40
41
42
43
44
45
46
47
48
49
50
51
52
53
54
55
56
57
58
59
60
61
62
63
64
65
66
67
68
69
70
71
72
73
74
75
76
77
78
79
80
81
82
83
84
85
86
87
88
89
90
91
92
93
94
95
96
97
98
99
100
101
102
103
104
105
106
107
108
109
110
111
112
113
114
115
116
117
118
119
120
121
122
123
124
125
126
127
128
129
130
131
132
133
134
135
136
137
138
139
140
141
142
143
144
145
146
147
148
149
150
151
152
153
154
155
156
157
158
159
160
161
162
163
164
165
166
167
168
169
170
171
172
173
174
175
176
177
178
179
180
181
182
183
184
185
186
187
188
189
190
191
192
193
194
195
196
197
198
199
200
201
202
203
204
205
206
207
208
209
210
211
212
213
214
215
216
217
218
219
220
221
222
223
224
225
226
227
228
229
230
231
232
233
234
235
236
237
238
239
240
241
242
243
244
245
246
247
248
249
250
251
252
253
254
255
256
257
258
259
260
261
262
263
264
265
266
267
268
269
270
271
272
273
274
275
276
277
278
279
280
281
282
283
284
285
286
287
288
289
290
291
292
293
294
295
296
297
298
299
300
301
302
303
304
305
306
307
308
309
310
311
312
313
314
315
316
317
318
319
320
321
322
323
324
325
326
327
328
329
330
331
332
333
334
335
336
337
338
339
340
341
342
343
344
345
346
347
348
349
350
351
352
353
354
355
356
357
358
359
360
361
362
363
364
365
366
367
368
369
370
371
372
373
374
375
376
377
378
379
380
381
382
383
384
385
386
387
388
389
390
391
392
393
394
395
396
397
398
399
400
401
402
403
404
405
406
407
408
409
410
411
412
413
414
415
416
417
418
419
420
421
422
423
424
425
426
427
428
429
430
431
432
433
434
435
436
437
438
439
440
441
442
443
444
445
446
447
448
449
450
451
452
453
454
455
456
457
458
459
460
461
462
463
464
465
466
467
468
469
470
471
472
473
474
475
476
477
478
479
480
481
482
483
484
485
486
487
488
489
490
491
492
493
494
495
496
497
498
499
500
501
502
503
504
505
506
507
508
509
510
511
512
513
514
515
516
517
518
519
520
521
522
523
524
525
526
527
528
529
530
531
532
533
534
535
536
537
538
539
540
541
542
543
544
545
546
547
548
549
550
551
552
553
554
555
556
557
558
559
560
561
562
563
564
565
566
567
568
569
570
571
572
573
574
575
576
577
578
579
580
581
582
583
584
585
586
587
588
589
590
591
592
593
594
595
596
597
598
599
600
601
602
603
604
605
606
607
608
609
610
611
612
613
614
615
616
617
618
619
620
621
622
623
624
625
626
627
628
629
630
631
632
633
634
635
636
637
638
639
640
641
642
643
644
645
646
647
648
649
650
651
652
653
654
655
656
657
658
659
660
661
662
663
664
665
666
667
668
669
670
671
672
673
674
675
676
677
678
679
680
681
682
683
684
685
686
687
688
689
690
691
692
693
694
695
696
697
698
699
700
701
702
703
704
705
706
707
708
709
710
711
712
713
714
715
716
717
718
719
720
721
722
723
724
725
726
727
728
729
730
731
732
733
734
735
736
737
738
739
740
741
742
743
744
745
746
747
748
749
750
751
752
753
754
755
756
757
758
759
760
761
762
763
764
765
766
767
768
769
770
771
772
773
774
775
776
777
778
779
780
781
782
783
784
785
786
787
788
789
790
791
792
793
794
795
796
797
798
799
800
801
802
803
804
805
806
807
808
809
810
811
812
813
814
815
816
817
818
819
820
821
822
823
824
825
826
827
828
829
830
831
832
833
834
835
836
837
838
839
840
841
842
843
844
845
846
847
848
849
850
851
852
853
854
855
856
857
858
859
860
861
862
863
864
865
866
867
868
869
870
871
872
873
874
875
876
877
878
879
880
881
882
883
884
885
886
887
888
889
890
891
892
893
894
895
896
897
898
899
900
901
902
903
904
905
906
907
908
909
910
911
912
913
914
915
916
917
918
919
920
921
922
923
924
925
926
927
928
929
930
931
932
933
934
935
936
937
938
939
940
941
942
943
944
945
946
947
948
949
950
951
952
953
954
955
956
957
958
959
960
961
962
963
964
965
966
967
968
969
970
971
972
973
974
975
976
977
978
979
980
981
982
983
984
985
986
987
988
989
990
991
992
993
994
995
996
997
998
999
1000
1001
1002
1003
1004
1005
1006
1007
1008
1009
1010
1011
1012
1013
1014
1015
1016
1017
1018
1019
1020
1021
1022
1023
1024
1025
1026
1027
1028
1029
1030
1031
1032
1033
1034
1035
1036
1037
1038
1039
1040
1041
1042
1043
1044
1045
1046
1047
1048
1049
1050
1051
1052
1053
1054
1055
1056
1057
1058
1059
1060
1061
1062
1063
1064
1065
1066
1067
1068
1069
1070
1071
1072
1073
1074
1075
1076
1077
1078
1079
1080
1081
1082
1083
1084
1085
1086
1087
1088
1089
1090
1091
1092
1093
1094
1095
1096
1097
1098
1099
1100
1101
1102
1103
1104
1105
1106
1107
1108
1109
1110
1111
1112
1113
1114
1115
1116
1117
1118
1119
1120
1121
1122
1123
1124
1125
1126
1127
1128
1129
1130
1131
1132
1133
1134
1135
1136
1137
1138
1139
1140
1141
1142
1143
1144
1145
1146
1147
1148
1149
1150
1151
1152
1153
1154
1155
1156
1157
1158
1159
1160
1161
1162
1163
1164
1165
1166
1167
1168
1169
1170
1171
1172
1173
1174
1175
1176
1177
1178
1179
1180
1181
1182
1183
1184
1185
1186
1187
1188
1189
1190
1191
1192
1193
1194
1195
1196
1197
1198
1199
1200
1201
1202
1203
1204
1205
1206
1207
1208
1209
1210
1211
1212
1213
1214
1215
1216
1217
1218
1219
1220
1221
1222
1223
1224
1225
1226
1227
1228
1229
1230
1231
1232
1233
1234
1235
1236
1237
1238
1239
1240
1241
1242
1243
1244
1245
1246
1247
1248
1249
1250
1251
1252
1253
1254
1255
1256
1257
1258
1259
1260
1261
1262
1263
1264
1265
1266
1267
1268
1269
1270
1271
1272
1273
1274
1275
1276
1277
1278
1279
1280
1281
1282
1283
1284
1285
1286
1287
1288
1289
1290
1291
1292
1293
1294
1295
1296
1297
1298
1299
1300
1301
1302
1303
1304
1305
1306
1307
1308
1309
1310
1311
1312
1313
1314
1315
1316
1317
1318
1319
1320
1321
1322
1323
1324
1325
1326
1327
1328
1329
1330
1331
1332
1333
1334
1335
1336
1337
1338
1339
1340
1341
1342
1343
1344
1345
1346
1347
1348
1349
1350
1351
1352
1353
1354
1355
1356
1357
1358
1359
1360
1361
1362
1363
1364
1365
1366
1367
1368
1369
1370
1371
1372
1373
1374
1375
1376
1377
1378
1379
1380
1381
1382
1383
1384
1385
1386
1387
1388
1389
1390
1391
1392
1393
1394
1395
1396
1397
1398
1399
1400
1401
1402
1403
1404
1405
1406
1407
1408
1409
1410
1411
1412
1413
1414
1415
1416
1417
1418
1419
1420
1421
1422
1423
1424
1425
1426
1427
1428
1429
1430
1431
1432
1433
1434
1435
1436
1437
1438
1439
1440
1441
1442
1443
1444
1445
1446
1447
1448
1449
1450
1451
1452
1453
1454
1455
1456
1457
1458
1459
1460
1461
1462
1463
1464
1465
1466
1467
1468
1469
1470
1471
1472
1473
1474
1475
1476
1477
1478
1479
1480
1481
1482
1483
1484
1485
1486
1487
1488
1489
1490
1491
1492
1493
1494
1495
1496
1497
1498
1499
1500
1501
1502
1503
1504
1505
1506
1507
1508
1509
1510
1511
1512
1513
1514
1515
1516
1517
1518
1519
1520
1521
1522
1523
1524
1525
1526
1527
1528
1529
1530
1531
1532
1533
1534
1535
1536
1537
1538
1539
1540
1541
1542
1543
1544
1545
1546
1547
1548
1549
1550
1551
1552
1553
1554
1555
1556
1557
1558
1559
1560
1561
1562
1563
1564
1565
1566
1567
1568
1569
1570
1571
1572
1573
1574
1575
1576
1577
1578
1579
1580
1581
1582
1583
1584
1585
1586
1587
1588
1589
1590
1591
1592
1593
1594
1595
1596
1597
1598
1599
1600
1601
1602
1603
1604
1605
1606
1607
1608
1609
1610
1611
1612
1613
1614
1615
1616
1617
1618
1619
1620
1621
1622
1623
1624
1625
1626
1627
1628
1629
1630
1631
1632
1633
1634
1635
1636
1637
1638
1639
1640
1641
1642
1643
1644
1645
1646
1647
1648
1649
1650
1651
1652
1653
1654
1655
1656
1657
1658
1659
1660
1661
1662
1663
1664
1665
1666
1667
1668
1669
1670
1671
1672
1673
1674
1675
1676
1677
1678
1679
1680
1681
1682
1683
1684
1685
1686
1687
1688
1689
1690
1691
1692
1693
1694
1695
1696
1697
1698
1699
1700
1701
1702
1703
1704
1705
1706
1707
1708
1709
1710
1711
1712
1713
1714
1715
1716
1717
1718
1719
1720
1721
1722
1723
1724
1725
1726
1727
1728
1729
1730
1731
1732
1733
1734
1735
1736
1737
1738
1739
1740
1741
1742
1743
1744
1745
1746
1747
1748
1749
1750
1751
1752
1753
1754
1755
1756
1757
1758
1759
1760
1761
1762
1763
1764
1765
1766
1767
1768
1769
1770
1771
1772
1773
1774
1775
1776
1777
1778
1779
1780
1781
1782
1783
1784
1785
1786
1787
1788
1789
1790
1791
1792
1793
1794
1795
1796
1797
1798
1799
1800
1801
1802
1803
1804
1805
1806
1807
1808
1809
1810
1811
1812
1813
1814
1815
1816
1817
1818
1819
1820
1821
1822
1823
1824
1825
1826
1827
1828
1829
1830
1831
1832
1833
1834
1835
1836
1837
1838
1839
1840
1841
1842
1843
1844
1845
1846
1847
1848
1849
1850
1851
1852
1853
1854
1855
1856
1857
1858
1859
1860
1861
1862
1863
1864
1865
1866
1867
1868
1869
1870
1871
1872
1873
1874
1875
1876
1877
1878
1879
1880
1881
1882
1883
1884
1885
1886
1887
1888
1889
1890
1891
1892
1893
1894
1895
1896
1897
1898
1899
1900
1901
1902
1903
1904
1905
1906
1907
1908
1909
1910
1911
1912
1913
1914
1915
1916
1917
1918
1919
1920
1921
1922
1923
1924
1925
1926
1927
1928
1929
1930
1931
1932
1933
1934
1935
1936
1937
1938
1939
1940
1941
1942
1943
1944
1945
1946
1947
1948
1949
1950
1951
1952
1953
1954
1955
1956
1957
1958
1959
1960
1961
1962
1963
1964
1965
1966
1967
1968
1969
1970
1971
1972
1973
1974
1975
1976
1977
1978
1979
1980
1981
1982
1983
1984
1985
1986
1987
1988
1989
1990
1991
1992
1993
1994
1995
1996
1997
1998
1999
2000
2001
2002
2003
2004
2005
2006
2007
2008
2009
2010
2011
2012
2013
2014
2015
2016
2017
2018
2019
2020
2021
2022
2023
2024
2025
2026
2027
2028
2029
2030
2031
2032
2033
2034
2035
2036
2037
2038
2039
2040
2041
2042
2043
2044
2045
2046
2047
2048
2049
2050
2051
2052
2053
2054
2055
2056
2057
2058
2059
2060
2061
2062
2063
2064
2065
2066
2067
2068
2069
2070
2071
2072
2073
2074
2075
2076
2077
2078
2079
2080
2081
2082
2083
2084
2085
2086
2087
2088
2089
2090
2091
2092
2093
2094
2095
2096
2097
2098
2099
2100
2101
2102
2103
2104
2105
2106
2107
2108
2109
2110
2111
2112
2113
2114
2115
2116
2117
2118
2119
2120
2121
2122
2123
2124
2125
2126
2127
2128
2129
2130
2131
2132
2133
2134
2135
2136
2137
2138
2139
2140
2141
2142
2143
2144
2145
2146
2147
2148
2149
2150
2151
2152
2153
2154
2155
2156
2157
2158
2159
2160
2161
2162
2163
2164
2165
2166
2167
2168
2169
2170
2171
2172
2173
2174
2175
2176
2177
2178
2179
2180
2181
2182
2183
2184
2185
2186
2187
2188
2189
2190
2191
2192
2193
2194
2195
2196
2197
2198
2199
2200
2201

turn operatively coupled, as schematically designated at 72, to the gas supply valve 74 of the water heater 10.

In the absence of clogging of the metal mesh area 54a, the pilot flame 50 (during non-firing periods of the main burner 30) has the small cross-section, concentrated vertical configuration shown in FIGS. 3 and 4 and heats the thermocouple 66 sufficiently so that it permits continued fuel flow from the valve 74 to the fuel supply tube 40 to sustain the pilot flame 50. However, when the mesh area 54a becomes sufficiently clogged over time with particulate matter 76 (such as lint, dirt, oil and the like) as shown in FIG. 5, the shape of the pilot flame changes by horizontally spreading out and vertically shortening to its configuration 50a schematically shown in FIG. 5. This reduces the electrical output from the thermocouple 66 in a manner causing the gas valve 74 to close, thereby terminating the generation of the pilot flame 50 and also precluding fuel delivery to the main burner 30.

To increase the sensitivity of the system 64 to particulate clogging of the burner 30, the mesh within the area 54a (see FIG. 60) may be provided with a considerably finer mesh spacing than that of the balance of the mesh 54. This makes the plugging detection function of the overall thermocouple-based system 64, which operates to monitor the shape of the pilot flame 50, more sensitive to such particulate clogging of the burner apparatus 28.

Compared to conventional pilot structures, the raw fuel jet-based pilot structure 32, which receives its combustion air from outside the combustion chamber 16, is simpler, uses less parts, uses less fuel and provides a more efficient pilot flame. Moreover, in a simple and efficient manner, the clogging detection system 64 functions to automatically shut down the water heater 10 when a burner clogging condition that may generate undesirable levels of carbon monoxide is sensed.

2005201241 22 Mar 2005

The foregoing detailed description is to be clearly understood as being given by way of illustration and example only, the spirit and scope of the present invention being limited solely by the appended claims.

The claims defining the invention are as follows:

1. Combustion apparatus comprising:
a wall structure defining a combustion chamber;
a main fuel burner disposed within said combustion chamber;
5 a pilot flame stabilizing structure disposed within said combustion chamber;
fuel delivery apparatus operable to receive fuel from a source thereof and
discharge the received fuel in the form of a fuel jet that impinges against said pilot flame
stabilizing structure; and
air delivery apparatus through which combustion air from outside said
10 combustion chamber is flowable to the discharged fuel jet to form therewith a fuel/air
mixture ignitable to create a pilot flame extending outwardly from said pilot flame
stabilizing structure.
2. The combustion apparatus of Claim 1 wherein:
said pilot flame stabilizing structure is defined by a portion of said main fuel
15 burner.
3. The combustion apparatus of Claim 2 wherein:
said pilot flame passes through said portion of said main fuel burner.
4. The combustion apparatus of Claim 3 further comprising:
a clogging detection system operative to sense a change in the shape of said pilot
20 flame indicative of clogging of said main fuel burner and responsively prevent further
generation of said pilot flame.
5. The combustion apparatus of Claim 4 wherein:
said combustion apparatus further comprises a fuel valve operative to selectively
permit fuel, from a source thereof, to flow through said fuel delivery apparatus, and
25 said clogging detection system includes a thermocouple positioned to be
impinged by said pilot flame and operative to close said fuel valve when said change in
the shape of said pilot flame occurs.
6. The combustion apparatus of Claim 2 wherein:
said main fuel burner is a radiant fuel burner.
- 30 7. The combustion apparatus of Claim 1 wherein:
said combustion chamber is a water heater combustion chamber.
8. A method of creating hot combustion products in the combustion
chamber of a fuel-fired heating appliance, said method comprising the steps of:
positioning a pilot flame stabilizing structure within said combustion chamber;

positioning a main fuel burner within said combustion chamber;
creating within said combustion chamber a fuel jet which impinges upon said pilot flame stabilizing structure;
mixing air from outside said combustion chamber with said fuel jet to form therewith a fuel/air mixture; and
igniting said fuel/air mixture to create a pilot flame extending outwardly from said pilot flame stabilizing structure and useable to ignite a fuel/air mixture subsequently supplied to said main fuel burner.

9. The method of Claim 8 wherein said method further comprises the step of:
utilizing a wall portion of said main fuel burner as said pilot flame stabilizing structure.

10. The method of Claim 8 wherein:
said step of positioning a main fuel burner within said combustion chamber is performed by positioning a radiant fuel burner within said combustion chamber.

11. The method of Claim 8 wherein:
said mixing step is performed within an interior portion of said main fuel burner.

12. The method of Claim 11 wherein:
said mixing step includes the step of flowing air from outside said combustion chamber through an enclosed path into said interior portion of said main fuel burner.

13. The method of Claim 9 wherein:
said wall portion of said main fuel burner has discharge openings therein, and said method further comprises the step of causing said fuel/air mixture to flow outwardly through said discharge openings, and
said igniting step is performed in a manner causing said pilot flame to form on an outer surface of said wall portion of said main fuel burner.

14. The method of Claim 13 further comprising the step of:
sensing a change in the shape of said pilot flame indicative of clogging of said main fuel burner and responsively preventing further generation of said pilot flame.

15. The method of Claim 14 wherein:
said sensing step includes the step of causing said pilot flame to impinge upon a thermocouple.

16. A fuel-fired heating appliance comprising:
a combustion chamber thermally communicatable with a fluid to be heated;

a main burner disposed within said combustion chamber; and
a pilot burner structure disposed within said combustion chamber for igniting
said main burner and including:

5 a flame stabilizing structure disposed within said combustion structure;
fuel delivery apparatus operable to receive fuel from a source thereof
and discharge the received fuel in the form of a fuel jet that impinges against said flame
stabilizing structure; and

10 air delivery apparatus through which combustion air from outside said
combustion chamber is flowable through an enclosed flow path to adjacent the discharged
fuel jet to form therewith a fuel/air mixture ignitable to create a pilot flame extending
outwardly from said flame stabilizing structure.

17. Fuel combustion apparatus comprising:

a hollow burner body having an outer wall portion with fuel/air discharge
openings therein;

15 a fuel delivery tube extending into the interior of said burner body, said fuel
delivery tube being operative to receive pressurized fuel from a source thereof and
discharge from an opening therein a fuel jet which impinges against the interior surface of
said outer wall portion; and

20 an air delivery conduit extending into the interior of said burner body and
operative to deliver combustion air from a source thereof to the discharged fuel jet to
form therewith a fuel/air mixture passing outwardly through discharge openings in a
section of said outer wall portion and being ignitable to form a pilot flame extending
outwardly from said outer wall portion.

25 18. Combustion apparatus substantially as hereinbefore described with
reference to the accompanying drawings.

19. A method of creating hot combustion products in the combustion
chamber of a fuel-fired heating appliance, the method substantially as hereinbefore
described with reference to the accompanying drawings.

30 20. A fuel-fired heating appliance substantially as hereinbefore described
with reference to the accompanying drawings.

Dated 5 March, 2008
Rheem Manufacturing Company
Patent Attorneys for the Applicant/Nominated Person
SPRUSON & FERGUSON

+

1/2

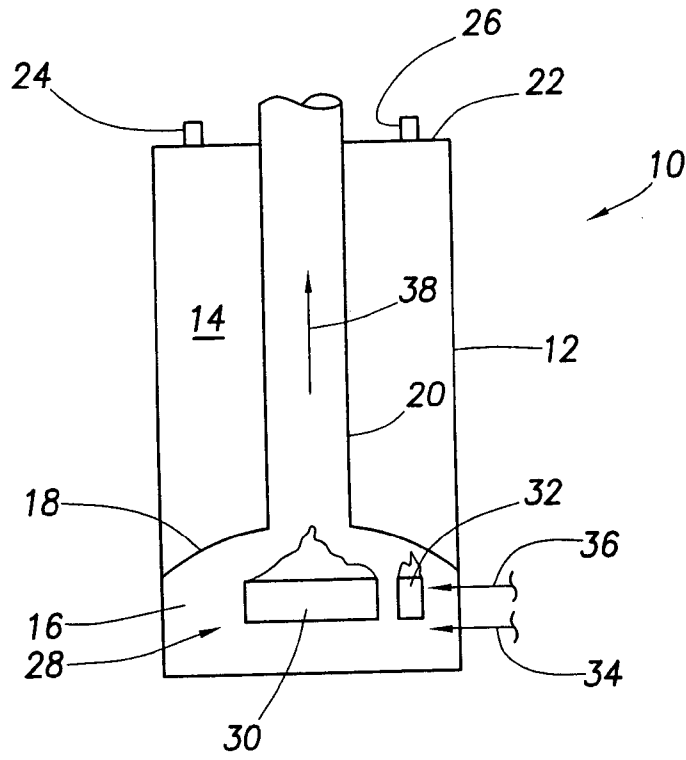

FIG. 1

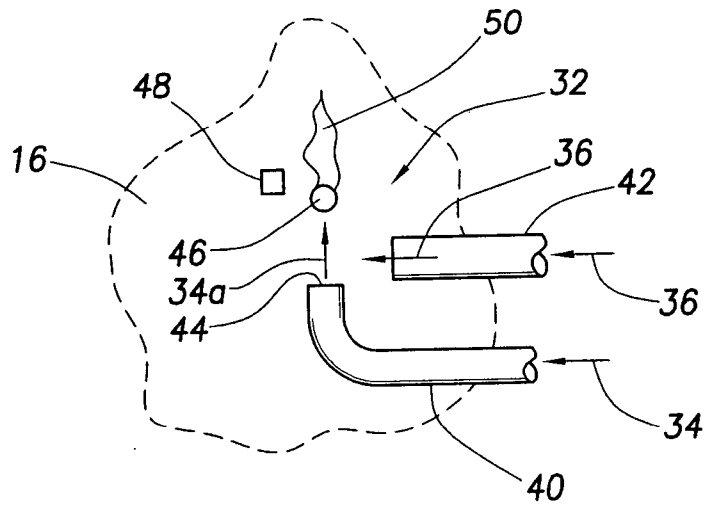

FIG. 2

+

+

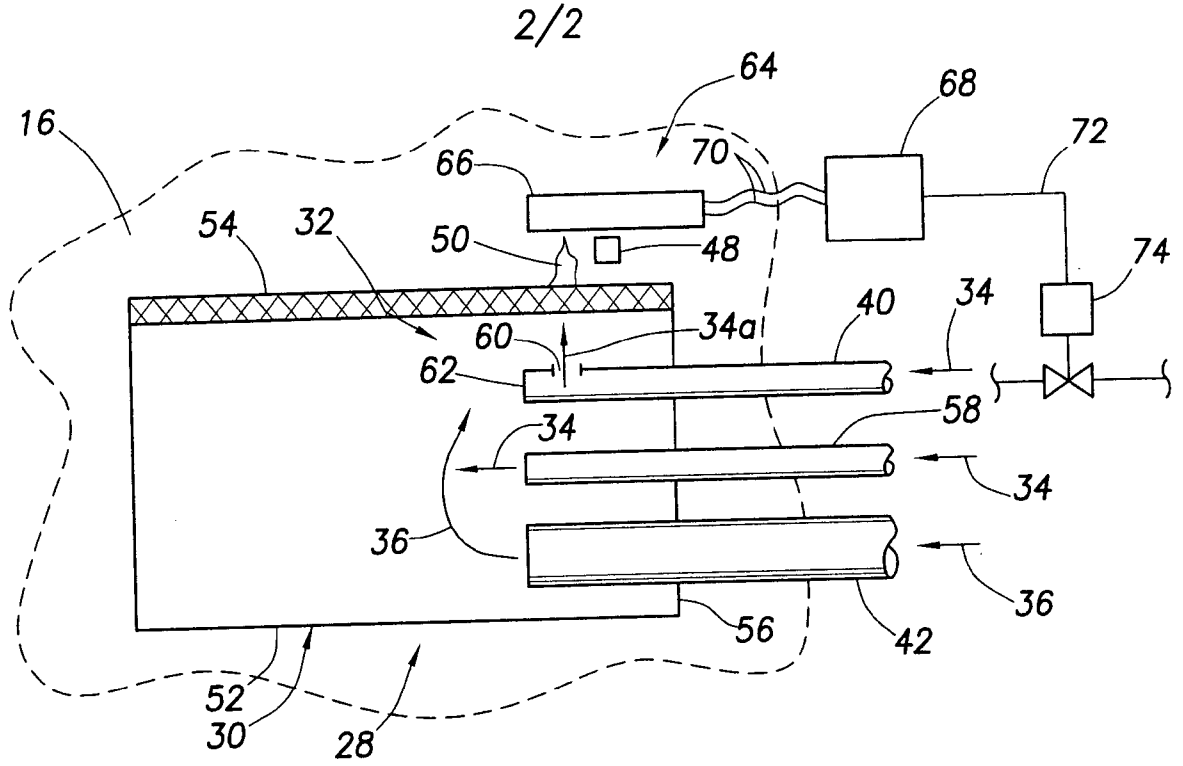

FIG. 3

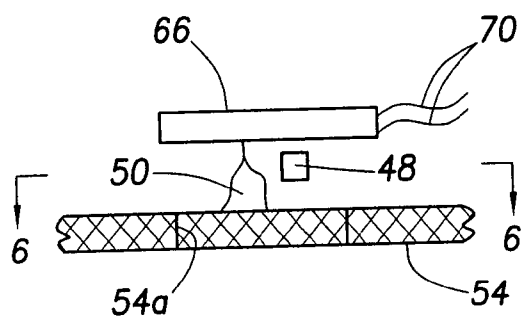

FIG. 4

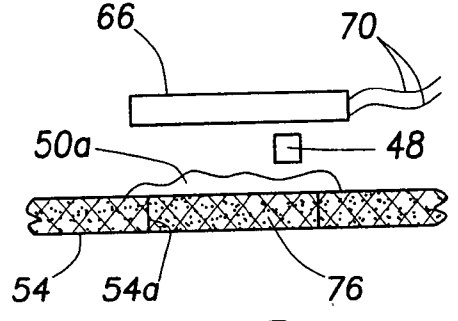

FIG. 5

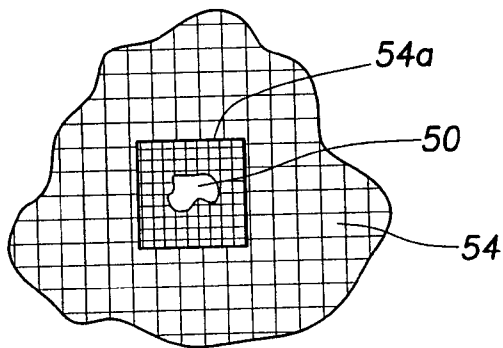

FIG. 6

+