

E. HOPKINSON.
ELECTRIC LOCOMOTIVE.

No. 522,834.

Patented July 10, 1894.

Fig. 2.

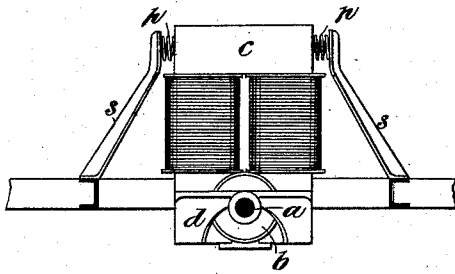

Fig. 1.

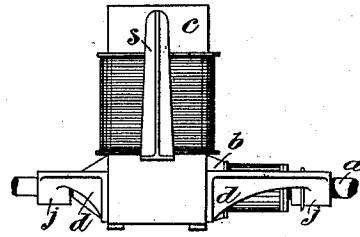

Fig. 3.

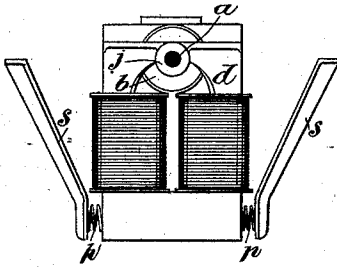

Fig. 4.

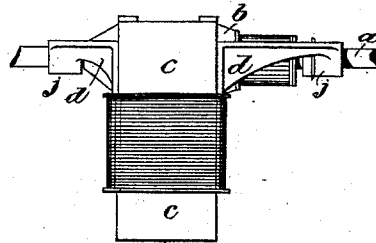
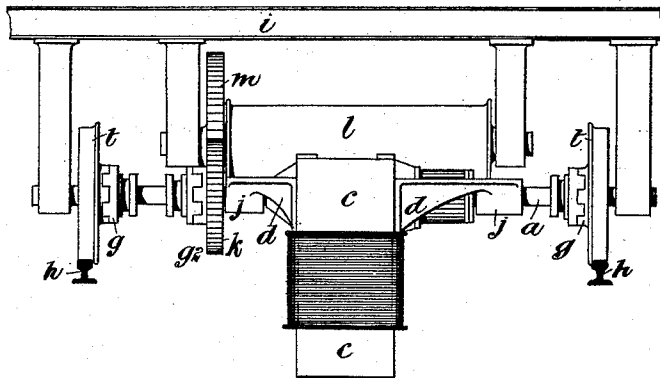

Fig. 5.



Witnesses:
Markin Alley
Willis Stanton

Inventor:
Edward Hopkinson
by *Pollo A. Mauro*
his attorneys

E. HOPKINSON.
ELECTRIC LOCOMOTIVE.

No. 522,834.

Patented July 10, 1894.

Fig. 7.

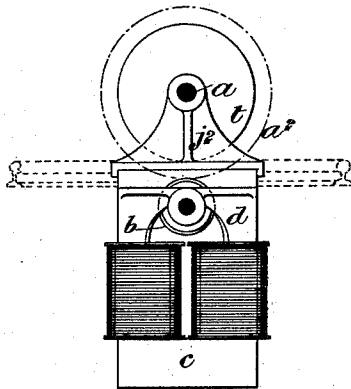

Fig. 8.

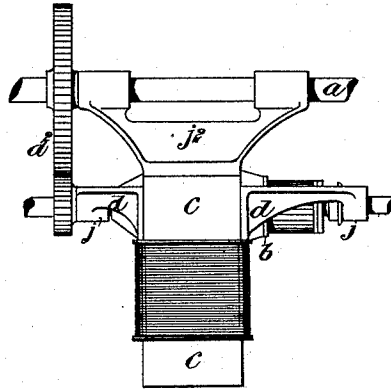
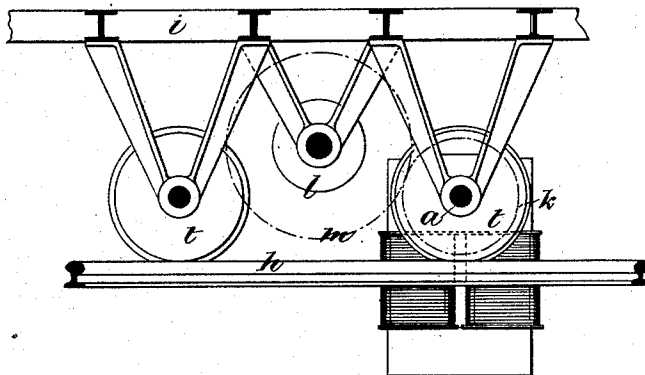

Fig. 6.



Witnesses:
James D. Kelly
Will H. Ketchum

Inventor:
Edward Hopkinson
 by *Drew A. Mauro*
 his attorneys.

UNITED STATES PATENT OFFICE.

EDWARD HOPKINSON, OF MANCHESTER, ENGLAND.

ELECTRIC LOCOMOTIVE.

SPECIFICATION forming part of Letters Patent No. 522,834, dated July 10, 1894.

Application filed July 21, 1891. Serial No. 400,198. (No model.) Patented in England March 14, 1888, No. 3,981.

To all whom it may concern:

Be it known that I, EDWARD HOPKINSON, engineer, a subject of the Queen of Great Britain and Ireland, residing at Salford Iron Works, Manchester, in the county of Lancaster, England, have invented certain Improvements in and Connected with Means for Driving, Controlling, and Working Electrically-Propelled Vehicles, Cranes, and the Like, (for which I have obtained a patent in Great Britain, No. 3,981, dated March 14, 1888,) of which the following is a specification.

The revolving axle or shaft of the motor dynamo of an electric locomotive tram car or other vehicle is generally independent of the axles of the vehicle, the driving connection being effected by gearing; but it has been proposed that the revolving armature of the motor should be built on one of the axles of the vehicle so as to avoid all intermediate gearing. To facilitate the application of this method I carry the magnets and pole pieces of the motor dynamo, between which the armature revolves, wholly or in part directly from the axle (and not from the framework of the car as is usual) supporting their weight on sleeves, bearings or journals in which the axle revolves. The center of gravity of the magnets and pole pieces may be in any convenient position relative to the axle. If it be vertically above the axle the whole weight will be carried on the axle, and the motion of the magnets and pole pieces will require to be restricted by guides or stops attached to the framework. In such cases it is convenient to insert a spring between the stops and the magnets or pole pieces which may be either a spiral compression or extension spring, or an india-rubber spring, or a laminated spring. In many cases the most convenient position for the magnets is such that they are in the same horizontal plane as the axle or approximately so. Their weight must then be supported in part from the framework of the vehicle and a portion only of such weight will rest directly on the axle through the journals. The support from the framework may in this case be conveniently effected by a spring or link which will allow certain limited freedom of motion of the magnets and pole pieces round the axle as an axis. Or the center of gravity may be below

the axle, in which case the weight will oppose the forces tending to cause the magnets to rotate round the armature. Stops or guides connected with the framework may be made use of in this case also, but this method of constructing or arranging the motor makes it possible to have two wheels and a single axle only to the vehicle, the carriage or framework being so constructed that the center of gravity of it and the magnets and pole pieces is below the axle. It will be observed that, in each of these arrangements, the magnets and pole pieces may have limited freedom of motion through a small angle round the axle, but this motion being circular only the armature which revolves with the axle must always remain central in the fields or pole pieces. By this means any rising or falling of the frame is compensated for by the angular movement of the magnets and pole pieces, and the jar and vibration in starting are largely absorbed by the spring stops or buffers.

My invention is also applicable to geared motors, but in such cases the entire motor-dynamo, including the armature, is slung from the axle and is free to move about it, except in so far as its motion may be restricted by guides or stops. The shaft of the motor is then geared to the axle which may be done by any of the well known devices, for example by a spur pinion and either an external or an internal wheel upon which it is free to roll as the frame of the motor moves about the axle, or by a friction pinion, or by chain gear.

In the application of my invention to overhead-railways, such as are intended for use in warehouses and works for the transporting of goods or weights from one part to another, I may carry the rails by hangers from the roof or ceiling, or by brackets from the walls, and I may arrange the carriage or framework entirely or in part beneath the rails. When applied to overhead traveling cranes, instead of permanently fixing the wheels on the axle I may connect them by a clutch or sliding key or equivalent device, and use the same motor and axle for both the lifting and traveling motions. For the lifting motion the clutches or keys are thrown out and the wheels form the journals or bearings for the axle upon which the lifting barrel

may be fixed or to which it may be geared by any suitable gearing.

In order that my invention may be fully understood I will now describe with reference to the accompanying drawings and diagrams (in which like parts are denoted by the same letters in all the figures) the manner in which the same may be performed.

Figure 1 shows a side elevation and Fig. 2 an end elevation of a motor with its center of gravity above the axle, and arranged according to my invention for propelling a vehicle, car or locomotive carriage. Figs. 3 and 4 are similar views of an arrangement in which the magnets are suspended from the axle. Fig. 5 is an end elevation and Fig. 6 a partial side elevation of a crane or hoist, having the invention applied thereto. Figs. 7 and 8 are elevations at right angles to each other illustrating a modification.

In Figs. 1 and 2 the axle *a* of the vehicle is also the axle or spindle of the armature *b*, the armature being built upon it which may be done in the usual manner. The magnets and pole pieces *c* are supported by means of the brackets *d* from the axle *a* by journals *j j*. The magnets *c* can turn on these journals with an angular movement round the axle by which any unequal motion between the motor axle and the framework is compensated for. The angular movement of the magnets *c* is restricted by the side struts *s* and springs *p*, the struts being rigidly attached to the framework of the car.

In Figs. 3 and 4 the same motor is shown, but with the magnets suspended from the axle of the vehicle and with their center of gravity below the said axle. The arrangement is the same as that described with reference to Figs. 1 and 2, but inverted. In this case the stops or guides may be omitted and the magnets be allowed to hang freely, being maintained in a vertical or approximately vertical position by their own weight.

Figs. 5 and 6 show the application of my invention to cranes or hoists, Fig. 5 being a side elevation and Fig. 6 an end elevation of a crane in which the same motor is used both for traversing and lifting. As already described the armature is built on the axle and the magnets are suspended from it. The chain barrel *l* is carried in suitable bearings from the framework and is driven by any convenient train of gearing from the motor axle. The traversing wheels *t t* of the crane are mounted loosely on the axle *a* but are connected to and disengaged from it by clutches *g* or other equivalent device. By this means one clutch or its equivalent only is required, but in some cases it will be found most convenient to have a separate clutch as at *g*², or

other arrangement for putting the lifting barrel in and out of gear with the motor.

In Figs. 5 and 6 the motor axle runs in journals carried by the framework *i i*. When it is desired to traverse the crane along the rails *h h* the motor is started and the clutches *g g* are thrown into gear. The lifting barrel *l* is shown driven from the axle *a* by the pinion *k* and the wheel *m*. The pinion *k* is shown in the drawings as riding loosely on the axle but is fitted to a clutch (*g*²) so that when this is in gear the barrel is driven while in order to stop the barrel the said clutch *g*² is thrown out of gear. By these means both the traversing and the lifting operations may be performed at one time.

Figs. 7 and 8 show in end and side elevation a motor in which the armature *b* is independent of the axle *a*, but is geared to it by spur gear *a*². In this case the motor is entirely suspended by journaled suspenders *j*² *j*² from the axle and the pinion of the motor is free to roll upon the spur wheel on the axle, and the motion of the motor round the axle is opposed by its weight only.

The specific application of my invention to traveling cranes, as illustrated in Figs. 5 and 6, is not claimed herein, being reserved to my application, Serial No. 503,782, filed March 15, 1894.

Having now particularly described and ascertained the nature of my said invention and in what manner the same is to be performed, I declare that what I claim is—

1. In electric vehicles and the like, the combination with the driving axle, of a motor for propelling the same the armature of said motor being built upon said driving axle, and the magnets and pole pieces supported therefrom by journals which allow freedom of angular motion around the axle, rigid stops or guides fixed to the frame work, and springs interposed between said stops or guides and the frame of the magnet, whereby the angular motion of the latter is limited, substantially as described.

2. In electric vehicles, cranes and the like, the combination with the driving axle of a motor having its armature built upon an axle and its magnets and pole-pieces suspended beneath the axle from journals thereon, substantially as described.

In testimony whereof I have signed my name to this specification in the presence of two subscribing witnesses.

EDWARD HOPKINSON.

Witnesses:

GEO. MILNES,
W. Broughton.
JNO. C. CHEETHAM,
Winton.