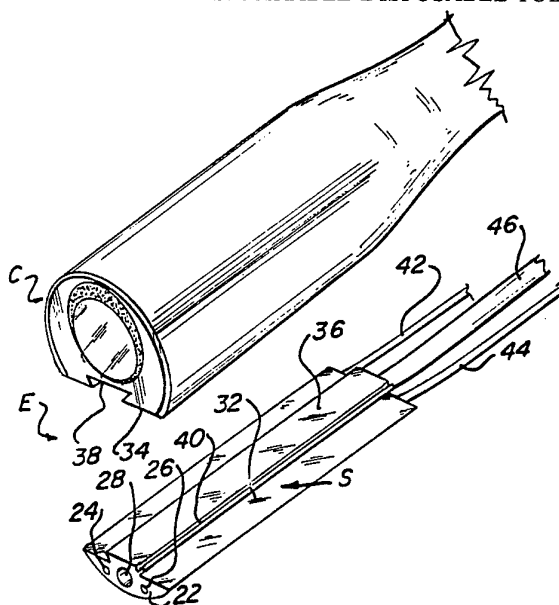




INTERNATIONAL APPLICATION PUBLISHED UNDER THE PATENT COOPERATION TREATY (PCT)

<p>(51) International Patent Classification ⁵ : A61B 1/04, 1/00, 1/12</p>	A1	<p>(11) International Publication Number: WO 94/05200 (43) International Publication Date: 17 March 1994 (17.03.94)</p>
<p>(21) International Application Number: PCT/US93/08292 (22) International Filing Date: 27 August 1993 (27.08.93) (30) Priority data: 938,629 1 September 1992 (01.09.92) US (60) Parent Application or Grant (63) Related by Continuation US 938,629 (CON) Filed on 1 September 1992 (01.09.92) (71)(72) Applicant and Inventor: ADAIR, Edwin, L. [US/US]; 317 Paragon Way, Castle Pines Village, CO 80104 (US).</p>		<p>(74) Agent: FIELDS, Gary, D.; Fields, Lewis, Pittenger & Rost, 1720 South Bellaire Street, Suite 1100, Denver, CO 80222 (US). (81) Designated States: CA, JP, US, European patent (AT, BE, CH, DE, DK, ES, FR, GB, GR, IE, IT, LU, MC, NL, PT, SE). Published <i>With international search report. Before the expiration of the time limit for amending the claims and to be republished in the event of the receipt of amendments.</i></p>

(54) Title: STERILIZABLE ENDOSCOPE WITH SEPARABLE DISPOSABLE TUBE ASSEMBLY



(57) Abstract

An endoscope (E, E', E'') has a sterilizable, reusable, elongated, optical capsule section (C, C') and a separable, disposable, sterile channel section (S). The capsule (C, C') has a window at a distal end in front of an image sensor (14). Image transmitting electronic cables (16), connected to the image sensor (14), extend proximally from the capsule (C, C'). Light transmitting fibers (20) extend from the window proximally for transmitting light to a site under investigation from a remote light source. The channel section (S) is removably attached in a fixed position to the capsule (C) and has plurality of longitudinal channels (24, 26) for transmitting fluids or for receiving an operative instrument. A flexible tube is connected to the proximal end of each channel for supplying fluid or for manipulating the operative instrument from a remote location. The separable section (S) is disposable after use. An umbilicated balloon catheter (130) or a telescopic catheter (160) can be used to position the tethered endoscope (E) in a passageway. Circumferentially spaced fluid vents (176) can supply jets of gas or liquid selectively to position the endoscope (E). Alternatively, a magnet (184) can be used for manipulating a capsule (C) with a ferrous housing along a passageway by use of a strong magnet (184) located exteriorly thereof.

FOR THE PURPOSES OF INFORMATION ONLY

Codes used to identify States party to the PCT on the front pages of pamphlets publishing international applications under the PCT.

AT	Austria	FR	France	MR	Mauritania
AU	Australia	GA	Gabon	MW	Malawi
BB	Barbados	GB	United Kingdom	NE	Niger
BE	Belgium	GN	Guinea	NL	Netherlands
BF	Burkina Faso	GR	Greece	NO	Norway
BG	Bulgaria	HU	Hungary	NZ	New Zealand
BJ	Benin	IE	Ireland	PL	Poland
BR	Brazil	IT	Italy	PT	Portugal
BY	Belarus	JP	Japan	RO	Romania
CA	Canada	KP	Democratic People's Republic of Korea	RU	Russian Federation
CF	Central African Republic	KR	Republic of Korea	SD	Sudan
CG	Congo	KZ	Kazakhstan	SE	Sweden
CH	Switzerland	LI	Liechtenstein	SI	Slovenia
CI	Côte d'Ivoire	LK	Sri Lanka	SK	Slovak Republic
CM	Cameroon	LU	Luxembourg	SN	Senegal
CN	China	LV	Latvia	TD	Chad
CS	Czechoslovakia	MC	Monaco	TG	Togo
CZ	Czech Republic	MG	Madagascar	UA	Ukraine
DE	Germany	ML	Mali	US	United States of America
DK	Denmark	MN	Mongolia	UZ	Uzbekistan
ES	Spain			VN	Viet Nam
FI	Finland				

**"STERILIZABLE ENDOSCOPE WITH SEPARABLE
DISPOSABLE TUBE ASSEMBLY"**

Technical Field

This invention relates to a sterilizable and/or
5 "fluid immersable" endoscope and particularly to a
tethered endoscope with a separable disposable tube
assembly which can be replaced after each use and
resterilization of the endoscope.

Background Art

10 In recent years the popularity of endoscopic
surgery has proliferated. This has occurred because
of the advances in technology which allow smaller and
smaller endoscopes to be used, thereby permitting
operative procedures to be undertaken in a less
15 invasive manner for the patient than was previously
possible. Thus, the patient suffers less trauma and
recuperates much more rapidly and experiences less
pain and discomfort than with more conventional
surgical procedures.

20 Because of the sophisticated optics and electro-
optics contained in modern endoscopes, they generally
are very expensive. In order for this expense to be
justified, they must be reused with a large number of
patients.

25 Of course, multiple use means that the endoscope
must be sterilized or at least disinfected after use
with each patient prior to use with the next patient.
One protocol for sterilization involves immersing the
endoscope in a disinfectant solution for a
30 predetermined period of time. It is also important to
flush the channels which carry gases or fluids and
those channels which are used for receiving operative
instruments. Another protocol is to heat sterilize

the endoscope by placing it in an autoclave. However, the optics and electronics of many endoscopes will not permit them to be subjected to heat sterilization. When using the disinfectant, sometimes the endoscope
5 is not placed in the disinfecting solution for a sufficient length of time nor are the channels flushed out completely, because of the urgency to get the endoscope back into service as soon as possible. Over time, the disinfectant solution may lose some of its
10 strength, thereby limiting its effectiveness.

Because of these shortcomings, many studies have shown that transmission of infectious diseases from one patient to another has occurred in many instances. By way of example, transmission of salmonella typhi
15 has been reported. In addition, pseudomonas aeruginosa has been linked to endoscopy. Also, an outbreak of serratia marcescens has been associated with the use of a bronchoscope. Furthermore, hepatitis B has been transmitted by endoscopes when
20 the endoscopes were processed in an inappropriate manner between patients. Finally, with respect to endoscope used on AID's patients it has been found that the sterilizing procedures have not always removed contamination of the human immunodeficiency
25 virus (HIV). This list is not exhaustive by any means.

A high-level of disinfection failures among gastrointestinal endoscopes have been noted, as well as failures in bronchoscopes, laryngoscopes and other
30 devices. This may be due to the fact that they are long and narrow and have long and narrow channels which are difficult to clean.

From the foregoing, it is apparent that endoscopes which can be more easily and effectively
35 sterilized are needed.

Disclosure of the Invention

In accordance with the present invention, an improved endoscope in one configuration has been provided which has a sterilizable optical section and a disposable or throwaway channel section or tube assembly. The endoscope includes an elongated capsule, of the size of a medicinal capsule and having a substantially cylindrical housing with a transparent window at the distal end thereof, for containing the endoscope optics. An image sensor is mounted adjacent the window within the capsule. An image transmitting cable with multiple conductors each has a distal end connected to the image sensor circuit board and a proximal end connected to a video control unit. From the video control unit signals are transmitted to the video monitor which displays the image in black and white or color. Light transmitting fibers each have a distal end adjacent to the window within the capsule and extends proximally from the capsule for transmitting light to a site under investigation from a remote light source. A separable channel section is removably attached to the capsule in fixed relationship and has at least one longitudinal channel for transmitting fluids or for receiving an operative instrument. A flexible tube is connected to the proximal end of the channel for supplying fluid or for manipulating the operative instrument from a remote location. The separable channel section is disposable after use on a patient and the capsule is sterilizable for reuse with another separable channel section on the next patient.

More particularly, the image transmitting filaments and the light transmitting fibers are housed in a common conduit connected to the proximal end of

the capsule. The separable channel section is configured to form a part of the cylindrical housing and includes a longitudinal guide or key which is slidably engageable with the longitudinal guideway or keyway in the housing. Conveniently, the capsule may have a flat relief which is engageable with a flat side on the separable channel section. The separable section has a cylindrical section with the same radius as the radius of the housing, so that when the capsule and the separable section are fastened together, they form the complete cylindrical cross-sectional shape. They may also be configured to have an elliptical cross-sectional shape. The separable section includes a plurality of longitudinal channels which include at least one fluid transmitting channel and at least one operative channel connected to tubes for supplying gases or operative instruments from a remote location.

Other means of attachment of the disposable channel can be utilized. This can include a magnetic attachment or the use of a very strong elastic band. Those schooled in the construction of such disposable tubing devices may envision other methods of holding the detachable channel section in the releasable yet fixed, relationship to the steerable endoscope.

This same inventive concept can be used with a conventional endoscope, such as a rigid endoscope or a steerable endoscope having a sterilizable steerable optical section, and a separable throwaway channel section releasably connected in a fixed position to the optical section. In this structure, the throwaway channel section includes a distal housing releasably connected to the distal end of the optical section and a proximal housing releasably connected to the proximal end of the optical section with tubes interconnecting longitudinal channels in each housing.

These channels and interconnecting tubes provide passageways through which gases or instruments can be passed.

In another form of the invention, an umbilicated
5 balloon catheter having a tubular wall with an
inflatable balloon adjacent the distal end thereof
receives the capsule configured endoscope of this
invention therein so that the capsule is positioned
just beyond the distal end of the catheter with the
10 conduit connected to the capsule extending through the
catheter. Thus, the balloon can be inflated in the
passageway to position and guide the capsule. The
balloon can either be donut shaped or elongated.
Also, the tubular wall of the umbilicated balloon
15 catheter can have a plurality of longitudinal channels
for introducing any one of a variety of tools to the
site under investigation.

In another form of the invention, a telescopic
catheter can be used which has an outer tubular wall
20 folded back upon itself as a distal end of the
catheter to form an inner tubular wall fan folded or
telescoped within the outer wall and within a
cylindrical housing for storage before expansion. The
housing has means for admitting gas under pressure
25 into the space between the inner and outer tubular
walls to expand the catheter so that the distal end
moves in a distal direction to push the capsule which
is positioned just ahead of the distal end in the
distal direction. This device is generally referred
30 to as a toposcopic catheter developed by the National
Institute of Health (NIH).

In a still further embodiment, the capsule can be
provided with at least three gas vents equally spaced
around the periphery thereof for selectively receiving
35 gas from a gas delivery tube to guide the capsule

through the passageway. Alternatively, a strong magnet can be used for manipulating the capsule along a passageway with the magnet located exteriorally thereof.

5 In another embodiment, the capsule may be configured into a side viewing device, with the optical window facing sideways. Here the image sensor is positioned behind the prism, and the detachable and disposable channel section is stair-stepped to one
10 side and behind the laterally facing window.

By utilizing the separable endoscope of this invention, a novel method is provided wherein a sterile disposable tube assembly or channel section is attached to a sterilized endoscope having suitable
15 optics for transmitting light to a site under investigation and reproducing an image of the site at a remote location. The endoscope is inserted with the attached tube assembly into a passageway to the desired site. The site is investigated through the
20 endoscope and the necessary operative procedures are carried out through the tube assembly. The endoscope is then removed from the passageway whereupon the tube assembly is separated from the endoscope and thrown away and the endoscope is sterilized. After
25 sterilization a new sterile tube assembly is attached to the sterilized endoscope. This greatly minimized possible cross infection between patients.

Existing endoscopes with built-in operating channels, optics and electronics can be modified for
30 use with a separable throwaway channel section or tube assembly. This is accomplished by encapsulating the entire steerable endoscope in a translucent sterile covering of thin, heat shrinkable plastic tubing closed at the distal end. This condom shaped covering
35 can be placed over the endoscope and heat shrunk down

to a very tight fitting covering encasing and sealing all of the endoscope including the hard to clean operating channels therein. This effectively isolates the endoscope in a sterile sheath and bars any cross contamination to the patient from the endoscope. The disposable operating channel section is then mounted onto the sheath enclosed steerable endoscope adjacent the distal end thereof with an elastic band holding it in proper position. The disposable channel section has a concave mating surface to fit snugly around the rounded body of the steerable endoscope. The sheath has incorporated therein a nylon string extending longitudinally therealong which allows easy tearing of the sheath after use for removal. A new sterile sheath can be heat shrunk onto the endoscope for use on the next patient.

The endoscope of this invention, because of its very small size substantially reduces the size and weight compared to conventional devices resulting in considerably more comfort for the patient. One of the most traumatic experiences for patients is the insertion of very large diameter and very heavy endoscopes into the colon, stomach or bronchial tree.

With this last-described apparatus, a method has been provided for utilizing a separable channel section on a conventional endoscope. The method includes placing a sterile heat shrinkable sheath on the body of the endoscope and applying heat to the sheath to shrink it into sealing engagement with the endoscope body. The channel section is releasably attached to the distal end of the endoscope body around the sheath in a fixed position. The operative site is investigated and the necessary, operative procedures are performed. The endoscope is then removed, the channel section is separated from the

endoscope and thrown away and the sheath is removed from the endoscope and thrown away.

Brief Description of the Drawings

5 Figure 1 is a perspective view of an endoscope having a sterilizable optical capsule section with a throwaway or disposable tube assembly or channel section;

Figure 2 is a fragmentary exploded view of the endoscope of Figure 1;

10 Figure 3 is an enlarged vertical section, taken along line 3-3 of Figure 1;

Figure 4 is a perspective view of the endoscope of Figure 1 connected through a control member to suitable gas supplying and instrument supplying channels;

15 Figure 5 is an enlarged vertical section, taken along line 5-5 of Figure 4, showing the interior construction of the conduits for the capsule section and the separable channel section;

20 Figure 6 is a perspective view of a steerable electronic endoscope having a discardable tubular section;

Figure 7 is a perspective view showing the use of the invention in an umbilicated balloon catheter;

25 Figure 8 is an enlarged horizontal section, taken along line 8-8 of Figure 7, showing details of the balloon construction;

Figure 9 is a perspective view of the endoscope of this invention used with an alternative umbilicated balloon catheter;

30 Figure 10 is an enlarged horizontal section, taken along line 10-10 of Figure 9, showing details of the balloon construction;

Figure 11 is a perspective view of a telescopic catheter (also known as toposcopic catheter) used with the endoscope of this invention;

5 Figure 12 is an enlarged longitudinal section, taken along line 12-12 of Figure 11, showing details of the telescopic catheter;

Figure 13 is a perspective view of an alternative endoscope having gas vents for guiding it along a bodily passageway;

10 Figure 14 is an enlarged vertical section, taken along line 14-14 of Figure 13, showing the gas passageways connected to the vents;

Figure 15 is a section through a bodily passageway showing the catheter of Figure 13 therein;

15 Figure 16 is a section through the intestines of a patient showing the endoscope of this invention being drawn therealong by means of a strong magnet;

Figure 17 is a fragmentary perspective view of another still further embodiment of the endoscope of this invention utilizing a prism for side viewing;

20 Figure 18 is an enlarged end view of the endoscope of Figure 17;

Figure 19 is a fragmentary horizontal section, taken along line 19-19 of Figure 18 showing further details of the endoscope construction;

Figure 20 is a fragmentary perspective view of another alternative embodiment of the endoscope wherein the separable section is magnetically attached;

30 Figure 21 is an exploded view of the endoscope of Figure 20;

Figure 22 is an enlarged vertical section, taken along line 22-22 of Figure 20;

35 Figure 23 is a fragmentary perspective view of yet another embodiment wherein the sterilizable

capsule and the separable section are held together by an elastic band;

Figure 24 is an enlarged vertical section, taken along line 24-24 of Figure 23;

5 Figure 25 is a fragmentary exploded view of the endoscope of Figure 23;

Figure 26 is a perspective view of a conventional steerable endoscope having a removable sterile sheath;

10 Figure 27 is an enlarged section, taken along line 27-27, showing the construction of the sheath;

Figure 28 is a perspective view of the endoscope with the sheath in place, showing it being heat shrunk onto the endoscope;

15 Figure 29 is an enlarged fragmentary horizontal section, taken along line 29-29 of Figure 28, showing the heat shrunk sheath in place on the end of the endoscope;

20 Figure 30 is a fragmentary exploded perspective view of the end of the endoscope of Figure 26 with the heat shrunk sheath in place and showing the separable section and an elastic band for holding it in place;

Figure 31 is a fragmentary perspective view of the apparatus of Figure 30 when assembled; and

25 Figure 32 is an exploded fragmentary perspective view of the endoscope assembly being disassembled after use.

Best Mode For Carrying Out The Invention

In accordance with one form of this invention, a tethered endoscope E is provided as best seen in
30 Figures 1-4 which includes a sterilizable capsule C to which a disposable or throwaway separable section S is releasably attached. Capsule C, which is easily sterilizable by heat in an autoclave, by gas sterilization or by dipping it in a disinfectant, has
35 a window 10 at the distal end thereof. Positioned

directly behind the window is a lens system 12 for focusing an image at a site under investigation on to a image receptor, such as CCD chip 14. It will be understood that other types of image receptors, such as a CID and MOS device or coherent optic fibers for guiding an image to a remotely located camera can be provided. However, under present technology, the CCD chip is the only electronic receptor of sufficiently small size to be placed in a capsule of the type contemplated by this invention. In this regard, the capsule is the size of a medicinal capsule, being 0.7 cm in diameter and 1.5 cm in length. Thus, it is small enough to be swallowed by a patient or otherwise introduced into small bodily passageways. The CCD is connected to electronic cable 16, shown in Figure 6 which extend through a conduit 18 to a remote location, as will be more fully described below. The CCD is at least partially surrounded by optical fibers 20 for transmitting light to the operative site for viewing by means of the CCD 14. These optical fibers also extend through conduit 18. Conveniently, conduit 18 will have a diameter of only 1/16 of an inch or smaller. This structure can be sterilized easily by immersing it in a disinfectant solution or by placing it in an autoclave for heat sterilization or by using ethylene oxide for gas sterilization.

Conveniently, separable section S is removably connectable to capsule C in a fixed position and has a channel section or tube assembly 22 having a plurality of channels, such as channels 24 and 26 for introduction of gas, such as carbon dioxide gas, or for drawing a suction to remove fluid or tissue from the operative site. Also, one channel could be used to direct fluid under pressure to clean the end of the optics to assure precise viewing. Another channel

could be used to direct a flow of warm gas over the optics for drying the optics. A larger central channel 28 is provided through which an operative tool, such as tool 30 shown in Figure 4, can be provided. Although the tool is illustrated as being forceps, it will be understood that other instruments may be utilized. Conveniently, section S has a flat 32 which engages a flat surface 34 of capsule C and further includes a central longitudinally extending guide or key 36 which is engageable in a longitudinal guideway or keyway 38 formed in flat surface 34 on capsule C. In use, a sterilized capsule is attached to a new sterile separable section S whereupon endoscope E can be introduced into a passageway of the body of a patient by one of many methods to be described, so that suitable investigative and/or operative procedures can be undertaken.

Once the procedures are completed, the endoscope can be withdrawn. Section S is then separated from capsule C and thrown away and the capsule is sterilized by immersion in disinfectant or by placing it in an autoclave for heat sterilization or gas sterilization over an appropriate period of time. In this manner, the expensive optical portion of the endoscope E is preserved for multiple uses whereas the inexpensive and easily contaminated and hard to clean or sterilize disposable section S can be separated from capsule C and thrown away.

Conveniently, guideway 38 can be provided with an additional channel 40 as shown for the introduction of a guide wire which has been previously positioned in the body of the patient by a catheter in a conventional manner. Thus, after removal of the catheter over the guide wire, the capsule can be

placed on to the guide wire and slid therealong over channel 40 until it is also properly positioned.

Conveniently, tubes are connected to the proximal end of section S which are in communication with the channels therein. For example, a tube 42 is connected to channel 24 and a tube 44 is connected to channel 26. Similarly, a larger tube 46 is connected to larger operating channel 28. Each tube can be connected to a suitable connector, not shown, for introducing an appropriate fluid or instrument.

As best seen in Figure 4, an alternative arrangement is shown wherein the conduit 18 extends distally to a housing 50 to which it is releasably connected by fitting 52. Conveniently, the housing 50 has a removable section 54 to which tubes 42, 44 and 46 are connected. On the other side of housing 50, a conduit 56 is provided for connecting the light fibers to a suitable source of light through fitting 58. Similarly, a conduit 60 is provided for conducting the electrical signals to an image processing device through connector 62.

Similarly, connected to the back side of removable section 54 is a tube 64 which is in further communication with tube 42 and is connected to a luer lock 66. A second tube 68 is in fluid communication with tube 44 and is provided with a luer lock 70. A third tube 72 is in communication with operating tube 46 and is adapted to receive an instrument, such as instrument 30, which has a handle 74 connected directly to it.

The same inventive concepts just described can be applied to a steerable endoscope E', as best seen in Figure 6. This endoscope includes a barrel 80 with light fibers 82, for providing light to a site under investigation, and electronic cables 84 attached to a

CCD (not shown) for transmitting an image which is viewed through lens 86. As illustrated, light fibers 82 are connected through a fitting 88 to a light source 90. The CCD is connected to a camera 92, having controls 94, and supplying an image through conduit 96 to a video to a video control unit 97 and then to video monitor 98 via cable 99. The steering mechanism within barrel 80 is controlled, as by knob 100 and may be of the type shown in my U.S. Patent Application Serial No. 07/894,824, filed June 8, 1992 and entitled "Steerable Sheath For Use With Selected Removable Optical Catheter", or any other well-known steering device. In an alternative configuration, the imaging system of the steerable endoscope may be a coherent optical fiber bundle instead of a CCD.

A separable distal housing 102 is removably connected to the distal end of barrel 80 in the same manner in which separable section S is attached to capsule C in Figure 2. Housing 102 has a plurality of longitudinal channels, such as three, which are connected to a vacuum hose 104, a fluid hose 106 and an instrument tube 108. These are connected to a proximal housing 110 which also is of similar construction to separable section S, shown in Figure 2, and is releasably connected to barrel 80 in a similar manner. It is provided with longitudinal channels one of which respectively communicate vacuum hose 104 with vacuum hose 112 attached to the proximal end of housing 110 at one end and to a vacuum pump 114 at the other end. Another channel in housing 110 communicates fluid hose 106 with fluid hose 116 which is connected to a fluid pump 118. A third central channel in housing 110 communicates instrument tube 108 with instrument tube 120 for receiving an operative instrument, such as forceps 122.

As with endoscope E, steerable endoscope E' can be initially sterilized in a sterilizing solution or by heating it in an autoclave or by gas sterilization for a suitable period of time to kill any viruses or bacteria remaining on the endoscope from its previous use. A tube assembly T, which is sterile, can be attached to barrel 80 by sliding distal housing 102 and proximal housing 110 into position and connecting the respective tubes to the proximal end of proximal housing 110. The endoscope can then be used in a conventional manner and after use the tube assembly T can be separated from the endoscope and thrown away. This portion of the endoscope is that which is the most difficult to clean but also that which is the most inexpensive. The endoscope E' can be resterilized by putting it in an autoclave or by soaking it in a suitable disinfectant. Thereafter, it can be reconnected to a new sterile tube assembly for reuse.

Various methods are available for introducing endoscope E into the body. As previously explained, it is of very small size, being approximately the same size as a medicinal capsule. Thus, it can be swallowed and if necessary a metallic weight can be imbedded into the terminal end to aid in propulsion of the capsule through the gastrointestinal track.

A second method of insertion and propulsion is by use of an umbilicated balloon catheter 130, of the type shown in Figures 7 and 8, in which endoscope E can be preloaded. Preloading is of great help to the endoscopist because it saves him or her the time and trouble of inserting the devices over long distances inside exceptionally long operating channels. As can be seen in Figure 7, conduit 18 as well as tubes 42, 44 and 46 pass through a central passageway 132 in the

catheter and are attached to a connector 134 which has an optics portion 136 and a separable tube connector 138 which can be attached to the appropriate instrumentation, as previously described. The distal end of catheter 130 is provided with an inflatable balloon 140 which can be used to center the catheter in a body passageway 142 as best seen in Figure 8. The balloon provides a very safe non-traumatic guide when used in the bowel or colon. The wetness of these structures cause them to offer little resistance to the passage of the catheter to its desired location. The balloon is inflated through a tube 144 which is connected to a gas supply tube 146 whose proximal end is connected to a suitable connector 148. The umbilicated balloon catheter 130 can be provided with an additional channel 150 for introduction of a guide wire (not shown) to introduce umbilicated catheter 130 through a trochar (not shown) to the desired location within a patient's body in a conventional manner.

Another umbilicated balloon catheter 152 is shown in Figures 9 and 10 wherein the balloon 154 has a generally donut configuration, because it has less contact surface with the passageway it can be more easily manipulated therealong.

The endoscope E can also be inserted by use of a telescopic catheter 160, as shown in Figures 11 and 12. The generally cylindrical housing 162 is provided which has a distal cylindrical portion 164 to which an outer tubular wall is securely attached. This wall is folded back upon itself to form a distal end 168 to form an inner tubular wall 170 which is fan folded and telescoped within housing 162, as shown in Figure 12. This catheter can be preloaded with endoscope E, having capsule C extending beyond the distal end thereof and conduit 18 and tubes 42, 44 and 46

extending through the inner tubular wall 170 and out the proximal end, as shown. Housing 162 has a gas inlet 174 to which a gas supply hose 176 is connected. When gas is introduced under pressure, the distal end
5 168 of the catheter will be pushed in a distal direction, thereby moving capsule C in that same distal direction. Thus, the capsule can be moved into its appropriate location by the expansion of telescopic catheter 160.

10 An alternative form of endoscope E" is illustrated in Figures 13-15. This endoscope has a capsule C' with circumferentially and equally spaced fluid vents 176. A similar set of fluid vents 178 are provided adjacent the proximal end thereof. Fluid
15 vents 176 are supplied with a gas or liquid through supply tubes 180, whereas fluid vents 178 are supplied with a gas or liquid through supply tubes 182. When the endoscope E" is introduced into a bodily
20 passageway, such as passageway 184, shown in Figure 15, the fluid can be selectively controlled through remote control valves (not shown) connected to supply tubes 180 and 182 so that jets of gas or liquid can be ejected selectively through any one of vents 176 or
25 vents 178 in any combination so as to manipulate and guide the endoscope through the passageway.

Figure 16 shows the use of endoscope E within the intestines of patient wherein the endoscope is moved along the desired path by a strong magnet 184. An example of such a magnet is one made of Samarium
30 Cobalt which is available through the Hitachi Corporation of Midland, Michigan U.S.A. In this application, the endoscope housing is made of ferrous material.

A further embodiment is shown in Figures 17-19
35 wherein an endoscope E₁ is provided which has a capsule

C_a with a prism therein for viewing at right angles the instruments introduced through separable section S. In this regard, capsule C_a has a CCD chip 190 mounted adjacent the distal end thereof for receiving an image projected through a lens system 192 mounted distally thereof. Attached to the lens system is a prism 194 for viewing an image projected through a window 196, as shown. Optical fibers 198 surround the CCD and project light onto the operative site by means of prism 194.

Separable section S is identical to section S of Figure 1. It has a flat 32, which engages a flat surface 200 on capsule C_a , and a central longitudinally extending guide or key 36 which is engageable in a longitudinal guideway or keyway 202 formed in flat surface 200 on capsule C_a . Guideway 36 can be provided with an additional channel 40 for introduction of a guide wire, as best seen in Figure 18.

Yet another embodiment is shown in Figures 20-22, wherein an endoscope E_b has a sterilizable capsule C_b to which a separable section S_b is attached by means of a magnetic strip. Capsule C_b is substantially identical to capsule C of Figure 1. The capsule includes a CCD chip 208 having a lens 210 for focusing an image at the operative site thereon. Light transmitting fibers 212 are positioned around the CCD and lens structure for directing light to the operative site. Separable section S_b has fluid passageways 214 and 216 with an instrument passageway 218 of larger size therebetween. Passageway 214 is connected to a tube 218; passageway 216 is connected to tube 220 and operative passageway 218 is connected to tube 222. The flat surface of capsule of C_b is provided with a ferrous metal plate 226 having depending flanges 228 on opposite sides thereof.

Separable section S_b has a magnetic strip 230 which is held in place against plate 228 by magnetic attraction and is sized to fit within the flanges 228 to hold the separable section in a fixed but removable position.

5 Another embodiment is shown in Figures 23-25 wherein an endoscope E_c has a capsule C_c and a separable section S_c which are held together by an elastic band. Capsule C_c is substantially identical to capsule C_b in the previous embodiment except that it
10 includes a recess 234 around its periphery. Section S_c also has a corresponding recess 236 around its periphery for receiving and positioning an elastic band 238, thereby holding capsule C_c and Section S_c together in a fixed position during use.

15 A final embodiment is shown in Figures 26-32 wherein a conventional steerable endoscope E_d is provided with a sterile sheath 240 which is made of heat shrinkable material which is transparent and has a pull string 242 extending substantially the full
20 length of the sheath for ripping it open after use, as will be explained more fully below. The steerable endoscope E_d has a flexible body portion 244 whose proximal end is connected to a handle 246 having controls 248 and 250 for manipulating the distal end
25 252. It also includes one or more channels, not shown, which are used for passage of fluids and instruments when the endoscope is used in the conventional manner.

 When the endoscope is to be used in accordance
30 with this invention, the sterile sheath 240 is placed over the end of the endoscope and drawn up over body 244, thereby covering the channels and body, and heat is applied thereto, as by a forced air dryer 254, which causes the sheath 240 to seal tightly around
35 endoscope body 244. The sheath 240 is transparent so

as not to interfere with light or image transmission through the encased endoscope.

Next, a separable section S_d is attached to the distal end 252 of endoscope E_d over the sheath 240 and is fixedly held in place, as by a sterile elastic band 256. Separable section S_d is similar to the separable sections of the previous embodiments except that it has a concave surface 258 which mates with the outer surface of distal end 252 of endoscope E_d . When assembled, the apparatus will have the configuration shown in Figure 31 whereupon it can be inserted through a body passageway and used for its intended purpose. After use, band 56 is removed, as shown in Figure 32, and the sheath 240 is removed by pulling on string 242 which longitudinally rips the sheath apart so that it can be separated from endoscope E_d . Thus, the present application can be adapted for use with conventional endoscopes without modification thereof. This provides a means and method of reusing a conventional endoscope without encountering the expense, time delay and uncertainty associated with conventional resterilization procedures. Although a steerable endoscope has been illustrated and described, the sheath can be used also with a conventional rigid endoscope.

From the foregoing, the advantages of this invention are readily apparent. An endoscope has been provided which is of very small size having a sterilizable optical section and a disposable sterile tubular section which is removably but fixedly attached to the capsule so that after initial use, the tubular section can be separated from the optical section and thrown away. The optical section then is resterilized by heating it in an autoclave or by immersing it in a sterilizing solution for a suitable

length of time. After the optical section is
resterilized, a new sterile tubular section can be
attached to the resterilized optical section and the
endoscope reused. The device can be end viewing or,
5 by use of a prism, side viewing. A similar structure
can be provided on a steerable endoscope wherein the
tubular section is separable from the optical section
which is steerable. Additionally, the endoscope,
because of its small size can be introduced into the
10 body by swallowing since it is no larger than a
medicinal capsule. Other ways of introducing the
device are by umbilicated balloon catheters which
offer almost no resistance in the intestinal
passageways and serve to center the catheter within
15 the passageway. Another alternative is the use of a
telescopic catheter for placement of the endoscope in
the desired location. The endoscope can also be
provided with fluid vents which are selectively
supplied with fluid to steer the endoscope as it is
20 moved into a bodily passageway. Finally, a strong
magnet can be used outside the bodily passageway for
pulling the endoscope, having a ferrous housing, into
the desired location. In other embodiments, a
separable section can be fixedly attached to the
25 capsule by an elastic band or magnetically. Finally,
the separable section can be used with a
conventionally endoscope which has been sealed in a
sterile sheath.

This invention has been described in detail with
30 reference to particular embodiments thereof, but it
will be understood that various other modifications
can be effected within the spirit and scope of this
invention.

CLAIMS**I Claim:**

1. An improved endoscope having a sterilizable optical section and a throwaway sterile channel section, said endoscope comprising:

an elongated capsule, having a substantially
5 cylindrical housing with a transparent window at the distal end thereof, for containing the endoscope optics, and having a proximal end;

an image sensor mounted adjacent said window within said capsule;

10 image electronic cables having a distal end connected to said image sensor and extending proximally from said capsule for transmitting an image signal from said image sensor to a video control unit and then to a remote image display device;

15 at least one light transmitting fiber having a distal end adjacent said window within said capsule and extending proximally from said capsule for transmitting light to a site under investigation from a remote light source;

20 a separable channel section having at least one longitudinal channel for transmitting fluids or for receiving an operative instrument;

means for releasably attaching said separable channel section to said capsule; and

25 a flexible tube connected to the proximal end of said channel for supplying fluid or for manipulating the operative instrument from a remote location, said separable section being disposable after use on a patient, said capsule being
30 sterilizable for reuse with another new sterile separable section on the next patient.

2. Apparatus, as claimed in Claim 1, wherein:

said image transmitting electronic cable and
said light transmitting fiber are housed in a common
conduit connected to said proximal end of said
5 capsule.

3. Apparatus, as claimed in Claim 1, wherein:
said separable section is configured to form
part of said cylindrical housing and includes a
longitudinal key which is slidably engageable with a
5 longitudinal keyway in said housing.

4. Apparatus, as claimed in Claim 1, wherein:
said capsule is no larger than a medicinal
capsule.

5. Apparatus, as claimed in Claim 2, wherein:
said capsule has a diameter of 0.7 cm and a
length of 1.5 cm; and
said conduit has a diameter of 1/16 inches.

6. Apparatus, as claimed in Claim 1, further
including:
at least three fluid vents equally spaced
around the periphery of said capsule; and
5 a fluid delivery tube connected to each of
said fluid vents to selectively supply a gas or liquid
thereto to guide said capsule through a passageway.

7. Apparatus, as claimed in Claim 1, wherein:
said capsule is of ferrous materials for
manipulation along a passageway by use of a strong
magnet located exteriorly of the passageway.

8. Apparatus, as claimed in Claim 1, wherein:
said capsule is an end viewing device.

9. Apparatus, as claimed in Claim 1, further including:

a prism between said image sensor and said window, said window being mounted on the side of said capsule so that said capsule is a side viewing device.

10. Apparatus, as claimed in Claim 1, wherein said attaching means includes:

a longitudinal key on one of said capsule and said channel section; and

a longitudinal keyway on the other of said capsule and said channel section for releasably attaching said channel section to said capsule.

11. Apparatus, as claimed in Claim 1, wherein said attaching means includes:

an elastic band extending around said capsule and said channel section.

12. Apparatus, as claimed in Claim 1, wherein said attaching means includes:

a ferrous material on one of said capsule and said channel section; and

a magnetic strip on the other of said capsule and said channel section for releasably attaching said channel section to said capsule.

13. An improved endoscope having a sterilizable optical section and a throwaway sterile channel section, said endoscope comprising:

an elongated capsule, having a substantially cylindrical housing with a transparent window at the distal end thereof, for containing the endoscope optics, and having a proximal end;

an image sensor mounted adjacent said window within said capsule;

10 an image transmitting electronic cable having a distal end connected to said image sensor and extending proximally from said capsule for transmitting an image signal from said image sensor to a camera and then to a video control unit and then to
15 a remote image display device;

a plurality of optical fibers having distal ends adjacent said windows at least partially surrounding said image sensor;

a conduit connected to said proximal end of
20 said housing through which said electronic cable and optic fibers extend to a camera control unit and then to a remote image display device and light source, respectively;

a generally flat relief along one side of
25 said capsule;

a separable section having a flat side engageable with said flat relief and having a cylindrical section with the same radius as the radius of said housing so that when said capsule and said
30 separable section are together said separable section completes the cylindrical shape of said housing, said separable section further including a plurality of longitudinal channels therethrough, including at least one fluid transmitting channel and at least one
35 operative channel;

releasable locking means for connecting said flat relief and said flat side together to hold said capsule and said separable section in fixed relationship with respect to each other; and

40 a flexible tube connected to the proximal end of said channel for supplying fluid or for manipulating the operative instrument from a remote

location, said separable section being disposable
after use on a patient, said capsule being
45 sterilizable for reuse with another new sterile
separable section on the next patient.

14. Apparatus, as claimed in Claim 13, wherein:
said releasable locking means comprises:
a longitudinal keyway in one of said flat
relief and said flat side; and
5 a longitudinal key in the other of said flat
relief and said flat side for longitudinal sliding and
locking engagement with each other.

15. Apparatus, as claimed in Claim 13, further
including:
a coupling connected to said proximal end of
said conduit and said tubes and having means for
5 connecting suitable apparatus to each of said conduits
and tubes.

16. An improved endoscope having a sterilizable
optical or electro-optical section and a throwaway
sterile channel section, said endoscope comprising:
a sterilizable optical section having light
5 transmitting and image receiving means mounted within
an elongated sterilizable steerable sleeve, said
section having a distal end and a proximal end;
a separable, throwaway sterile section
releasably connected to said optical section in a
10 fixed position, said throwaway section including at
least one passageway for supplying fluid or for
receiving an operative device.

17. Apparatus, as claimed in Claim 16, wherein
said throwaway section further includes:

a distal housing releasably connected to
said distal end of said optical section and having at
5 least one longitudinal channel therethrough;

a proximal housing releasably connected to
said proximal end of said optical section and having
at least one longitudinal channel therethrough; and

10 a tube interconnecting each channel of said
distal channel with a corresponding channel of said
proximal housing to form each said passageway.

18. Apparatus, as claimed in Claim 17, further
including:

a first releasable locking means for
releasably connecting said distal housing to said
5 distal end of said optical section; and

a second releasable locking means for
releasably connecting said proximal housing to said
proximal end of said optical section.

19. Apparatus, as claimed in Claim 18, wherein
each of releasable locking means comprises:

a longitudinal channel in one of said
optical section and said housing; and

5 a longitudinal key in the other of said
optical section and said housing for mating engagement
with said channel.

20. A tethered endoscope comprising:

an improved endoscope having a sterilizable
optical section and a throwaway sterile channel
section, said endoscope comprising:

5 an elongated capsule, having a substantially
cylindrical housing with a transparent window at the
distal end thereof, for containing the endoscope
optics, and having a proximal end;

an image sensor mounted adjacent said window
10 within said capsule;

an image transmitting electronic cable
having a distal end connected to said image sensor and
extending proximally from said capsule for
transmitting an image signal from said image sensor to
15 a camera and then to a video control unit and then to
a remote image display device;

at least one light transmitting fiber having
a distal end adjacent said window within said capsule
and extending proximally from said capsule for
20 transmitting light to a site under investigation from
a remote light source;

a common conduit connected to said proximal
end of said capsule housing said image transmitting
electronic cable and said light transmitting fiber;

25 an umbilicated balloon catheter having a
tubular wall with an inflatable balloon adjacent a
distal end thereof, said capsule being positioned just
beyond said distal end of said catheter with said
conduit extending therethrough; and

30 at least one longitudinal channel extending
longitudinally within said tubular wall in fluid
communication with said balloon for inflation of said
balloon to center said capsule in a passageway into
which said catheter has been introduced.

21. Apparatus, as claimed in Claim 20, further
including:

a plurality of longitudinal channels within
said tubular wall for introducing fluids or tools to
5 the site under investigation.

22. A tethered endoscope comprising:

an elongated capsule, having a substantially cylindrical housing with a transparent window at the distal end thereof, for containing the endoscope optics, and having a proximal end;

an image sensor mounted adjacent said window within said capsule;

image transmitting electronic cable having a distal end connected to said image sensor and extending proximally from said capsule for transmitting an image signal from said image sensor to a remote image display device;

at least one light transmitting fiber having a distal end adjacent said window within said capsule and extending proximally from said capsule for transmitting light to a site under investigation from a remote light source;

a common conduit connected to said proximal end of said capsule housing said image transmitting electronic cables and said light transmitting fiber;

a telescopic catheter having an outer tubular wall folded back upon itself as a distal end of said catheter at a distal location to form an inner tubular wall telescoped within said outer wall;

a generally cylindrical housing in which the telescoped portion of said inner wall is stored before expansion, said housing including a distal end to which said proximal end of said outer wall is attached and a proximal end to which said proximal end of said inner wall is attached, said capsule being positioned just beyond said distal end of said catheter with said conduit extending through said inner tubular wall and out said proximal end of said housing; and

means in said housing for admitting gas under pressure into the space between said inner and outer tubular walls to expand said catheter so that

said distal end moves in a distal direction to push said capsule in said distal direction.

23. A separable channel device for use with a conventional endoscope having a body with a distal end and channels for transmitting fluids or receiving operative instruments, said device comprising:

5 a heat shrinkable sheath for placing over the distal end and a substantial portion of the body in sealing relationship thereto;

a separable channel section having at least one longitudinal channel therethrough;

10 a tube attached to said channel for passage of fluid or an operative instrument; and

means for releasably attaching said channel section to said sheath adjacent the distal end of the endoscope in a fixed position.

24. Apparatus, as claimed in Claim 23, wherein: said channel section has a concave surface to receive said sheath at the distal end of the endoscope.

25. Apparatus, as claimed in Claim 23, wherein: said attaching means is a sterile elastic band.

26. Apparatus, as claimed in Claim 23, further including:

5 a pull string attached to and running substantially the entire length of said sheath for ripping said sheath apart to remove said sheath from the endoscope after use.

27. A method of examining an operative site in the body of a patient and performing the necessary operative procedures with a conventional endoscope, said endoscope having a body with a distal end and channels for transmitting fluids or receiving operative instruments, said method comprising the steps of:

5
10 placing a sterile heat shrinkable sheath over the distal end and a substantial portion of the body;

applying heat along the sheath to shrink it into sealing engagement with the endoscope body;

15 removably attaching a sterile channel section to the distal end of the endoscope body around the sheath in a fixed position, inserting the endoscope with attached channel section into a body passageway of the patient to the desired site;

investigating the site through the endoscope;

20 carrying out necessary operative procedures through the tube assembly;

removing the endoscope and tube assembly from the passageway;

25 separating the channel section from the endoscope and throwing the channel section away; and

removing the sheath from the endoscope and throwing it away.

28. A method, as claimed in Claim 27, wherein: said step of removing the sheath includes: ripping the sheath longitudinally from one end to the other.

29. A method of examining a patient with an endoscope comprising:

attaching a sterile disposable channel
section in a fixed position to a sterilizable
5 endoscope having suitable optics for transmitting
light to a site under investigation and reproducing an
image of the site at a remote location;
inserting the endoscope with attached
channel section into a body passageway of the patient
10 to the desired site;
investigating the site through the
endoscope;
carrying out necessary operative procedures
through the tube assembly;
15 removing the endoscope and tube assembly
from the passageway;
separating the channel section from the
endoscope and throwing the tube assembly away;
sterilizing the endoscope; and
20 attaching a new sterile tube assembly to the
sterilized endoscope.

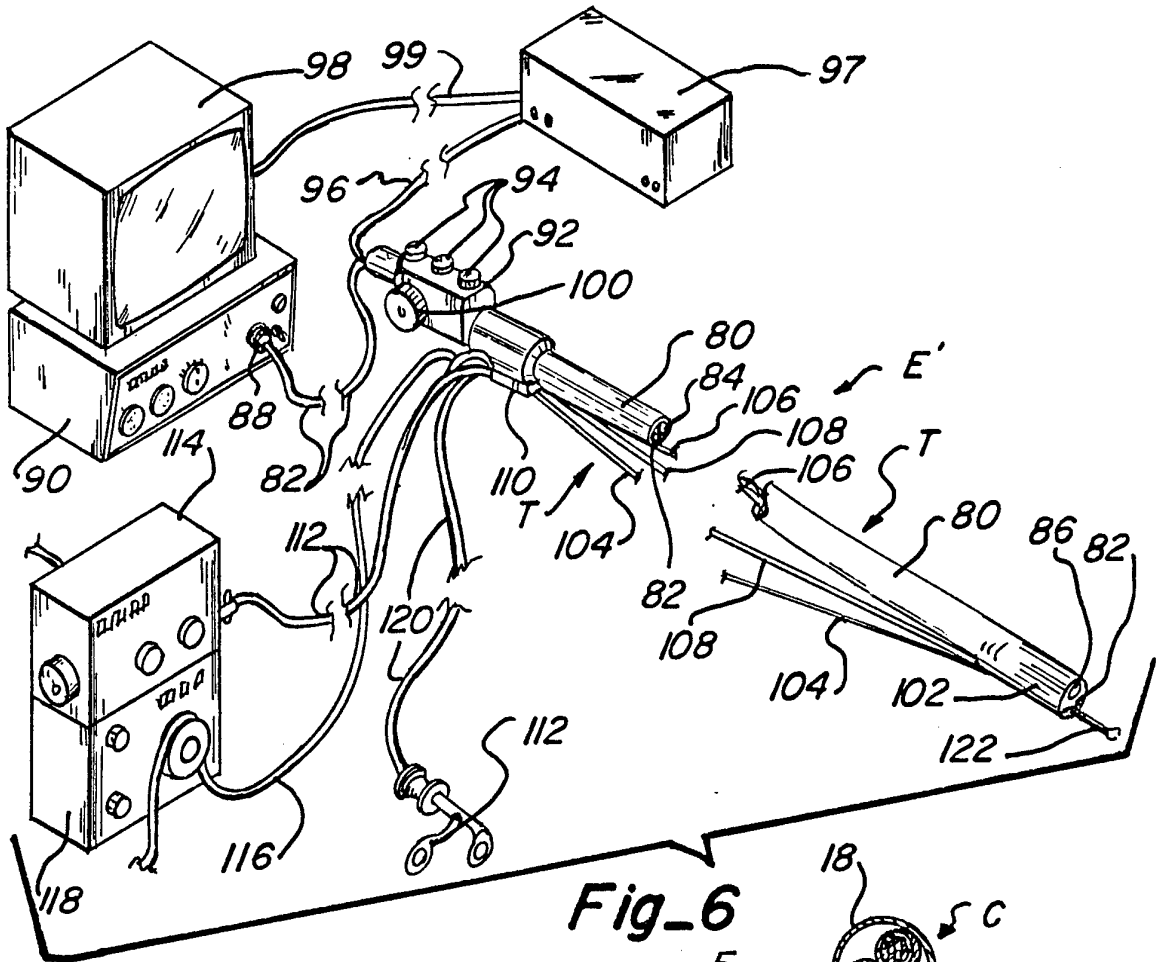


Fig-6

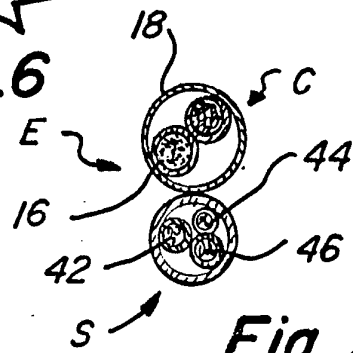


Fig-5

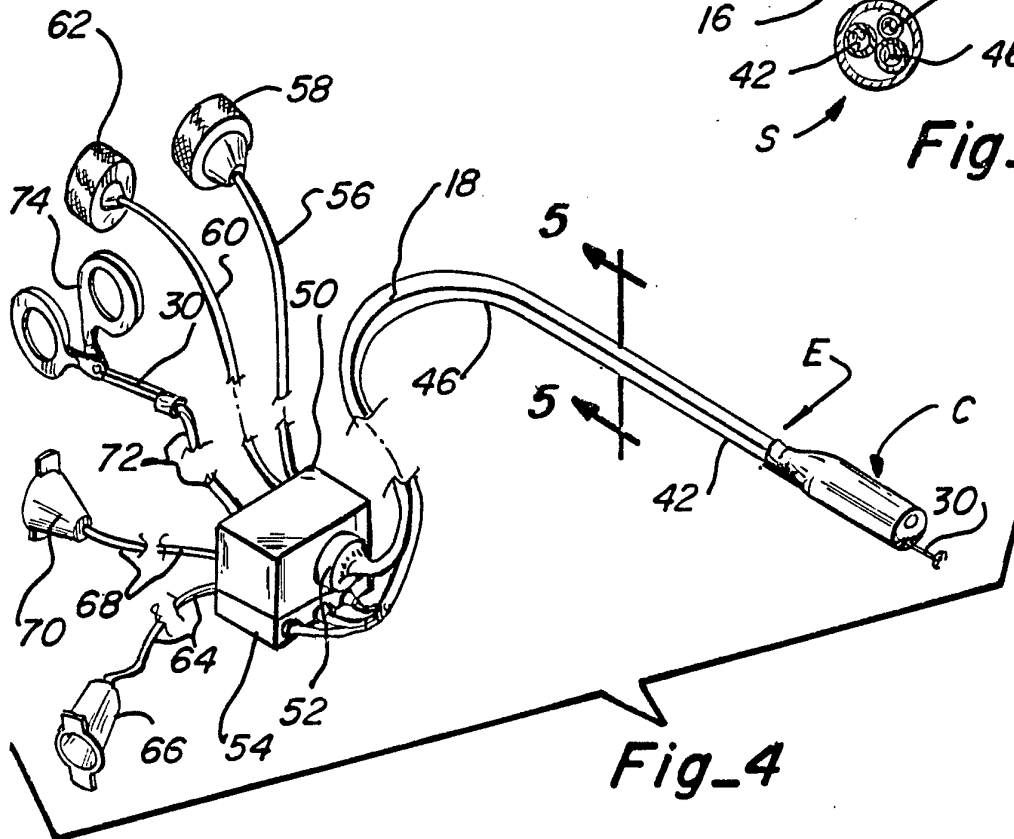
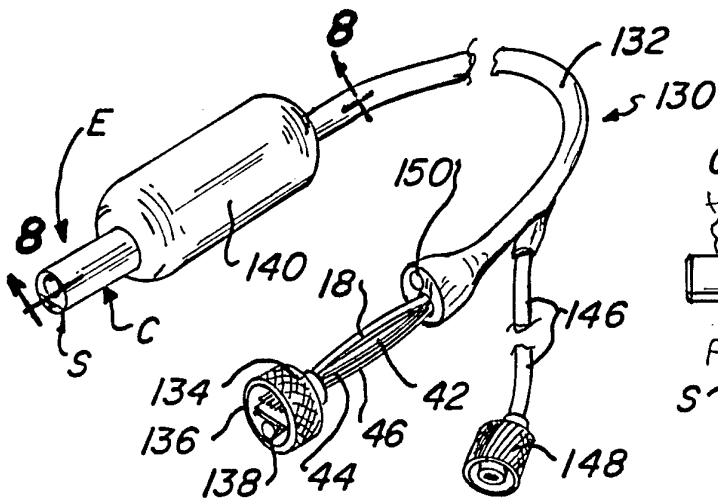
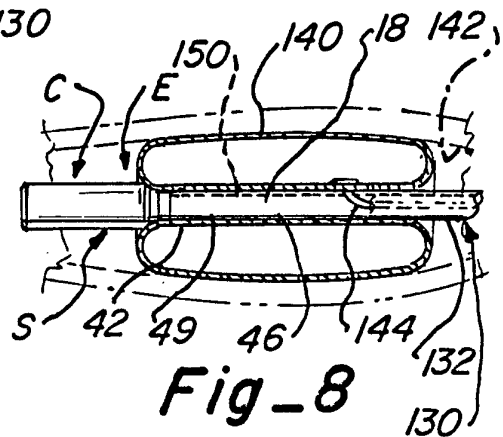


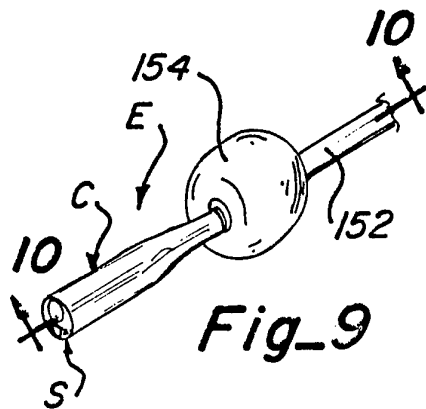
Fig-4



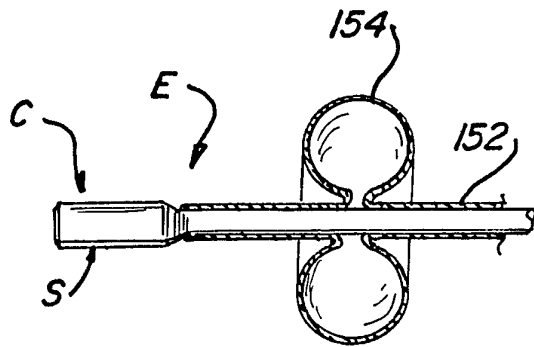
Fig_7



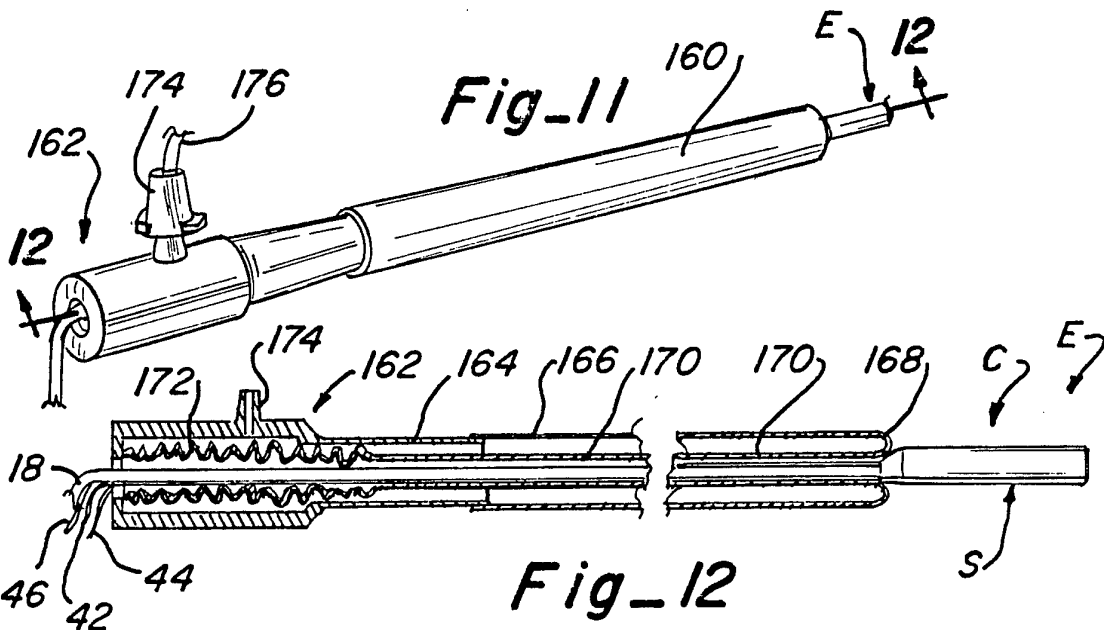
Fig_8



Fig_9

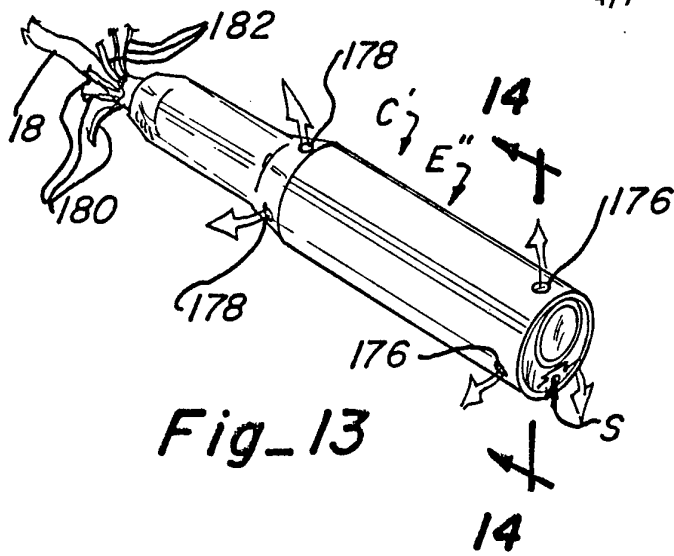


Fig_10

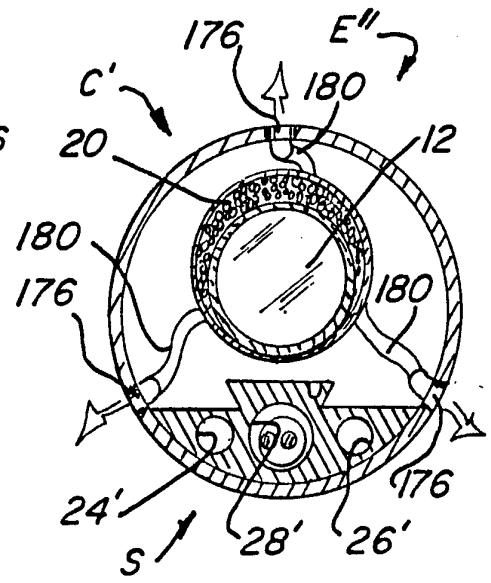


Fig_11

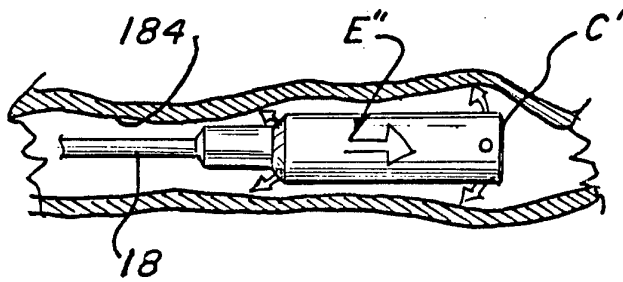
Fig_12



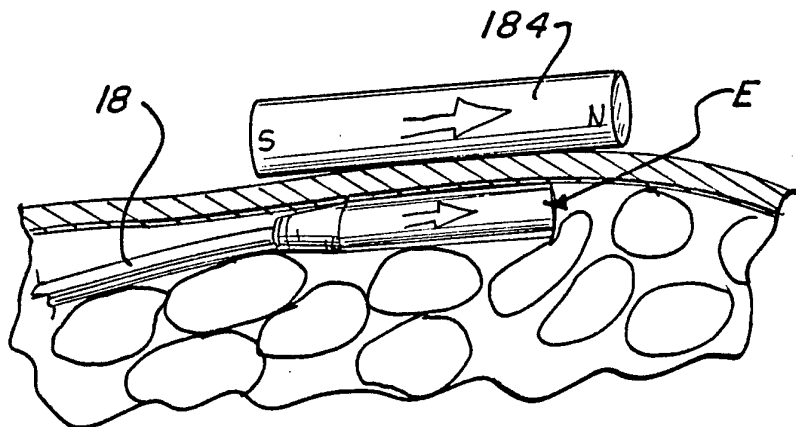
Fig_13



Fig_14

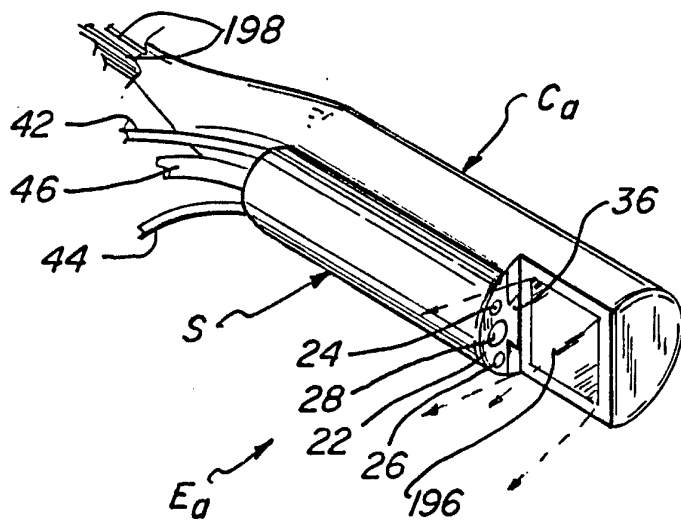


Fig_15

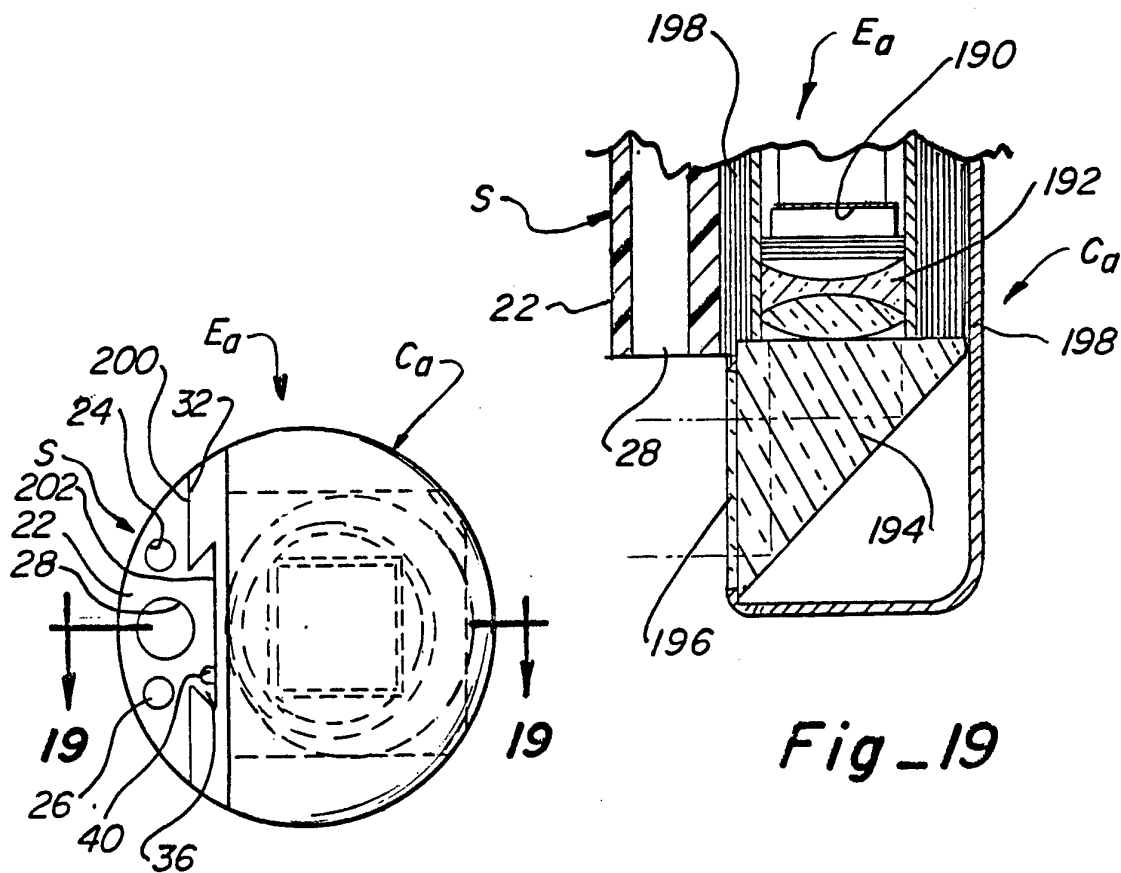


Fig_16

5/7

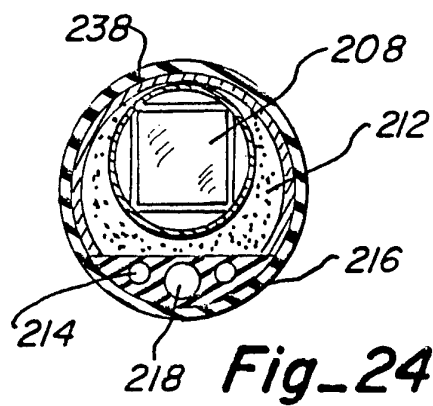
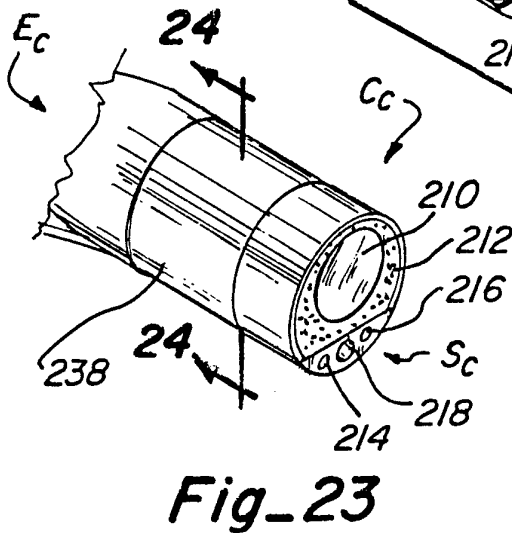
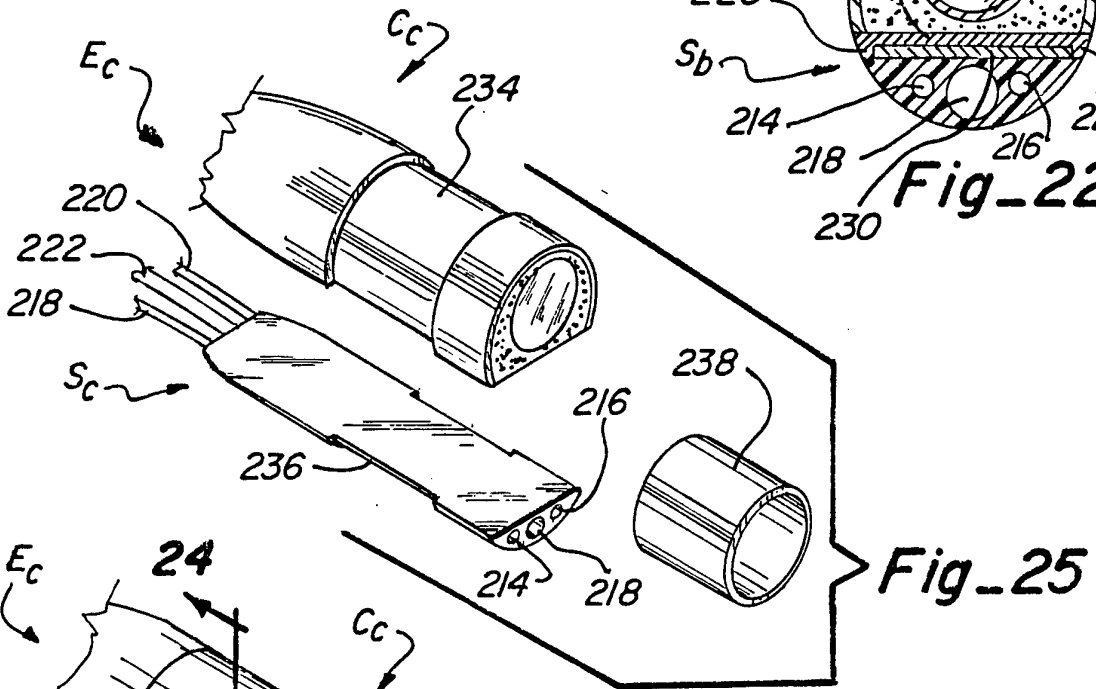
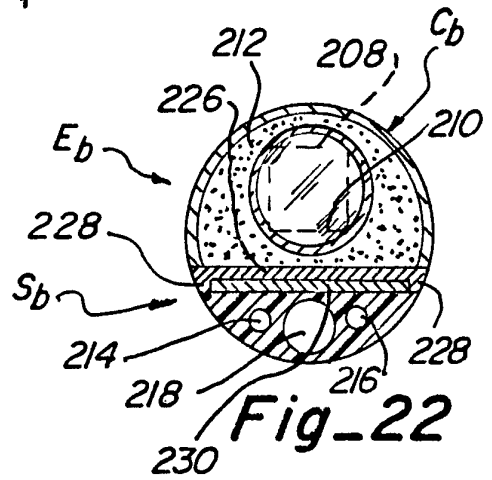
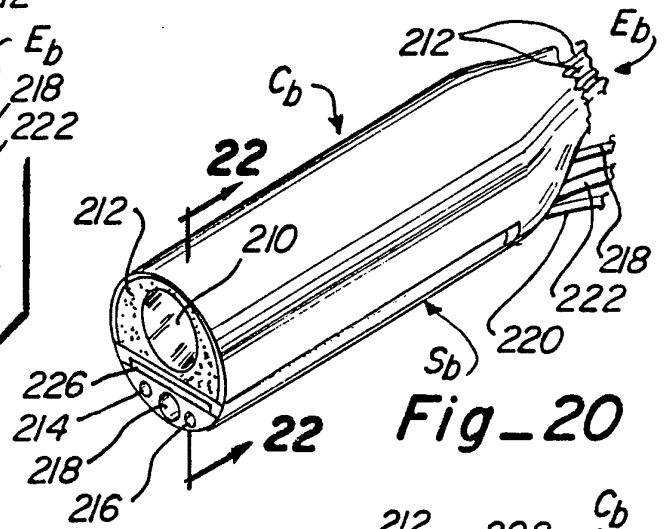
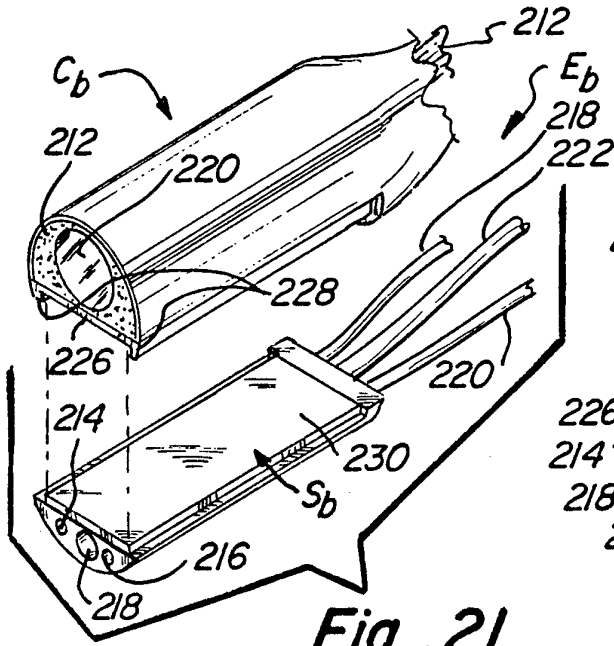


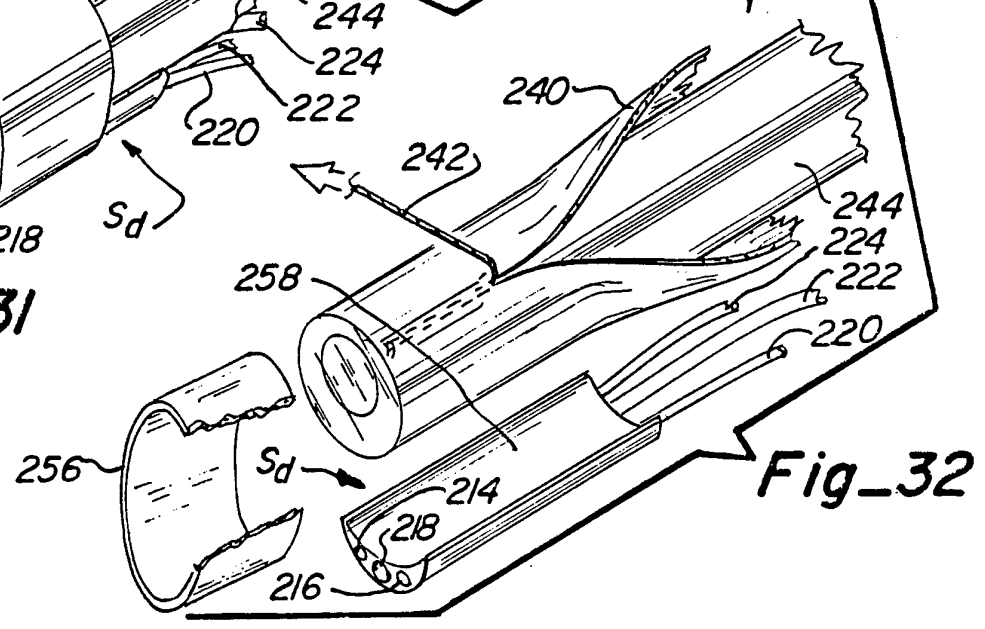
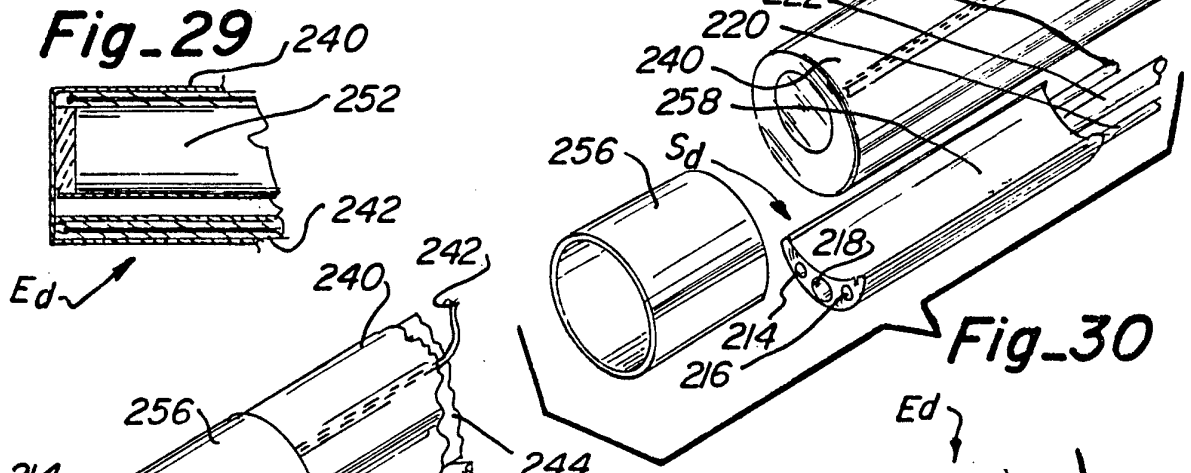
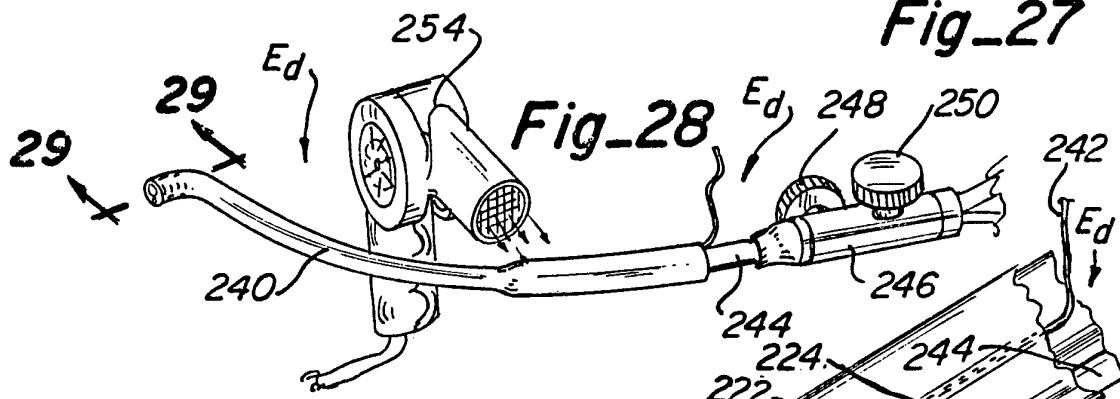
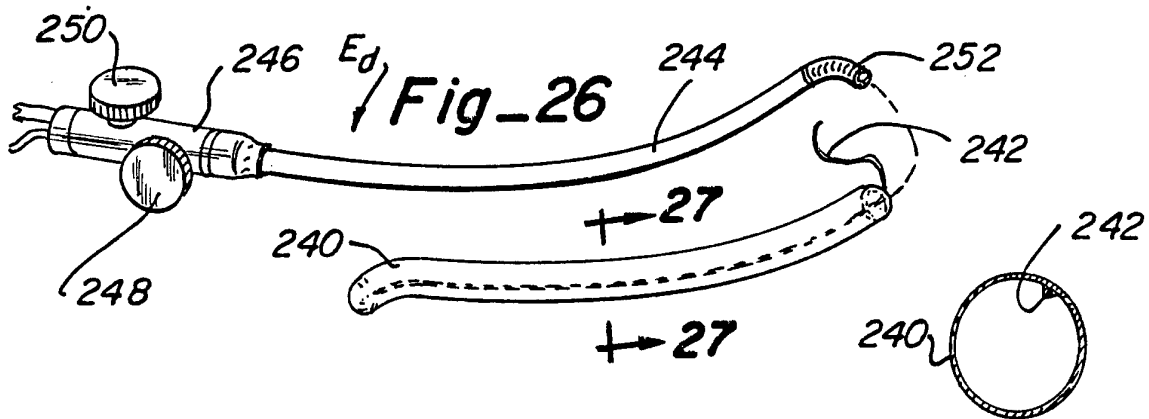
Fig_17



Fig_18

Fig_19





INTERNATIONAL SEARCH REPORT

International Application No

PCT/US 93/08292

A. CLASSIFICATION OF SUBJECT MATTER
 IPC 5 A61B1/04 A61B1/00 A61B1/12

According to International Patent Classification (IPC) or to both national classification and IPC

B. FIELDS SEARCHED

Minimum documentation searched (classification system followed by classification symbols)
 IPC 5 A61B

Documentation searched other than minimum documentation to the extent that such documents are included in the fields searched

Electronic data base consulted during the international search (name of data base and, where practical, search terms used)

C. DOCUMENTS CONSIDERED TO BE RELEVANT

Category *	Citation of document, with indication, where appropriate, of the relevant passages	Relevant to claim No.
X	EP,A,0 184 778 (F. E. SILVERSTEIN ET AL.) 18 June 1986	1,2,8, 11,16, 17,29
Y	see page 1, line 1 - page 2, line 19	20-22
A	see page 3, line 18 - line 36 see page 4, line 23 - page 7, line 4 see page 8, line 5 - line 27; figures	13,23,27
X	DE,A,39 09 290 (ASAHI KOGAKU KOGYO) 12 October 1989 see column 1, line 20 - line 37; claims; figures	1,8,16, 17,29
Y	DE,A,28 47 633 (OLYMPUS OPTICAL CO. LTD.) 10 May 1979 see page 7, line 17 - page 8, line 27; claims; figure 1	20-22
	-/--	

Further documents are listed in the continuation of box C.

Patent family members are listed in annex.

* Special categories of cited documents :

- *A* document defining the general state of the art which is not considered to be of particular relevance
- *E* earlier document but published on or after the international filing date
- *L* document which may throw doubts on priority claim(s) or which is cited to establish the publication date of another citation or other special reason (as specified)
- *O* document referring to an oral disclosure, use, exhibition or other means
- *P* document published prior to the international filing date but later than the priority date claimed

- *T* later document published after the international filing date or priority date and not in conflict with the application but cited to understand the principle or theory underlying the invention
- *X* document of particular relevance; the claimed invention cannot be considered novel or cannot be considered to involve an inventive step when the document is taken alone
- *Y* document of particular relevance; the claimed invention cannot be considered to involve an inventive step when the document is combined with one or more other such documents, such combination being obvious to a person skilled in the art.
- * & * document member of the same patent family

Date of the actual completion of the international search

5 January 1994

Date of mailing of the international search report

27. 01. 94

Name and mailing address of the ISA

European Patent Office, P.B. 5818 Patentlaan 2
 NL - 2280 HV Rijswijk
 Tel. (+ 31-70) 340-2040, Tx. 31 651 epo nl,
 Fax (+ 31-70) 340-3016

Authorized officer

Fontenay, P

INTERNATIONAL SEARCH REPORT

Internationa 1 Application No

PCT/US 93/08292

C.(Continuation) DOCUMENTS CONSIDERED TO BE RELEVANT

Category °	Citation of document, with indication, where appropriate, of the relevant passages	Relevant to claim No.
A	DE,A,39 42 905 (K. STORZ) 27 June 1991 see the whole document ---	20
A	PATENT ABSTRACTS OF JAPAN vol. 14, no. 453 (C-0764)28 September 1990 & JP,A,02 177 965 (M & M KK) 11 July 1990 see abstract ---	20
A	PATENT ABSTRACTS OF JAPAN vol. 16, no. 180 (C-0935)30 April 1992 & JP,A,04 022 325 (OLYMPUS OPTICAL CO LTD.) 27 January 1992 see abstract ---	7,12
P,X	WO,A,92 22238 (J. S. JONES) 23 December 1992 see page 2, line 30 - page 3, line 31 see page 6, line 33 - page 8, line 12; claims; figures -----	1,16,29

INTERNATIONAL SEARCH REPORT

Information on patent family members

International Application No

PCT/US 93/08292

Patent document cited in search report	Publication date	Patent family member(s)	Publication date
EP-A-0184778	18-06-86	US-A- 4646722	03-03-87
		CA-A- 1262246	10-10-89
		JP-C- 1633964	20-01-92
		JP-B- 2054734	22-11-90
		JP-A- 61179128	11-08-86

DE-A-3909290	12-10-89	JP-A- 1244732	29-09-89
		JP-C- 1721141	24-12-92
		JP-B- 3060486	13-09-91
		US-A- 5050585	24-09-91

DE-A-2847633	10-05-79	JP-C- 1322709	27-06-86
		JP-A- 54066582	29-05-79
		JP-B- 60051913	16-11-85

DE-A-3942905	27-06-91	US-A- 5048508	17-09-91

WO-A-9222238	23-12-92	US-A- 5201908	13-04-93
		AU-A- 2178892	12-01-93
