

(12) UK Patent Application (19) GB (11) 2 106 691 A

- (21) Application No 8227167
- (22) Date of filing 23 Sep 1982
- (30) Priority data
- (31) 8118505
- (32) 28 Sep 1981
- (33) France (FR)
- (43) Application published
13 Apr 1983
- (51) INT CL³
G09F 7/18
- (52) Domestic classification
G5C ES
- (56) Documents cited
GB A 2062745
GB A 2021945
GB 1602730
GB 1226744
- (58) Field of search
G5C
- (71) Applicants
Jean-Pierre Saine,
15 Rue du Chateau,
83440 Fayence,
France.
- (72) Inventors
Jean-Pierre Saine

- (74) Agents
J M Halstead,
54 Pine Walk,
Carshalton Beeches,
Surrey SM5 4HD.

(54) Notice show case

(57) A notice show case or notice board has a display panel 1 and a framed glass 10 pivotably hung thereon. The display panel has an upper side 2 which is bent forwardly and upturned over at least a portion of its length, thereby forming at the rear of the upturned portion 2a a bearing face 2b at an angle with respect to the upturned portion. An upper element 12a of the framed glass is recessed for receiving the upturned portion 2a. The panel 1 is screwed to a wall and may display information 17 by magnetic elements or drawing pins 18. The framed glass 10 is pivotably hung to fit around the outside of the panel 1 and is fixed in its closed position by a screw (16) passing through the lower overlapping sides.

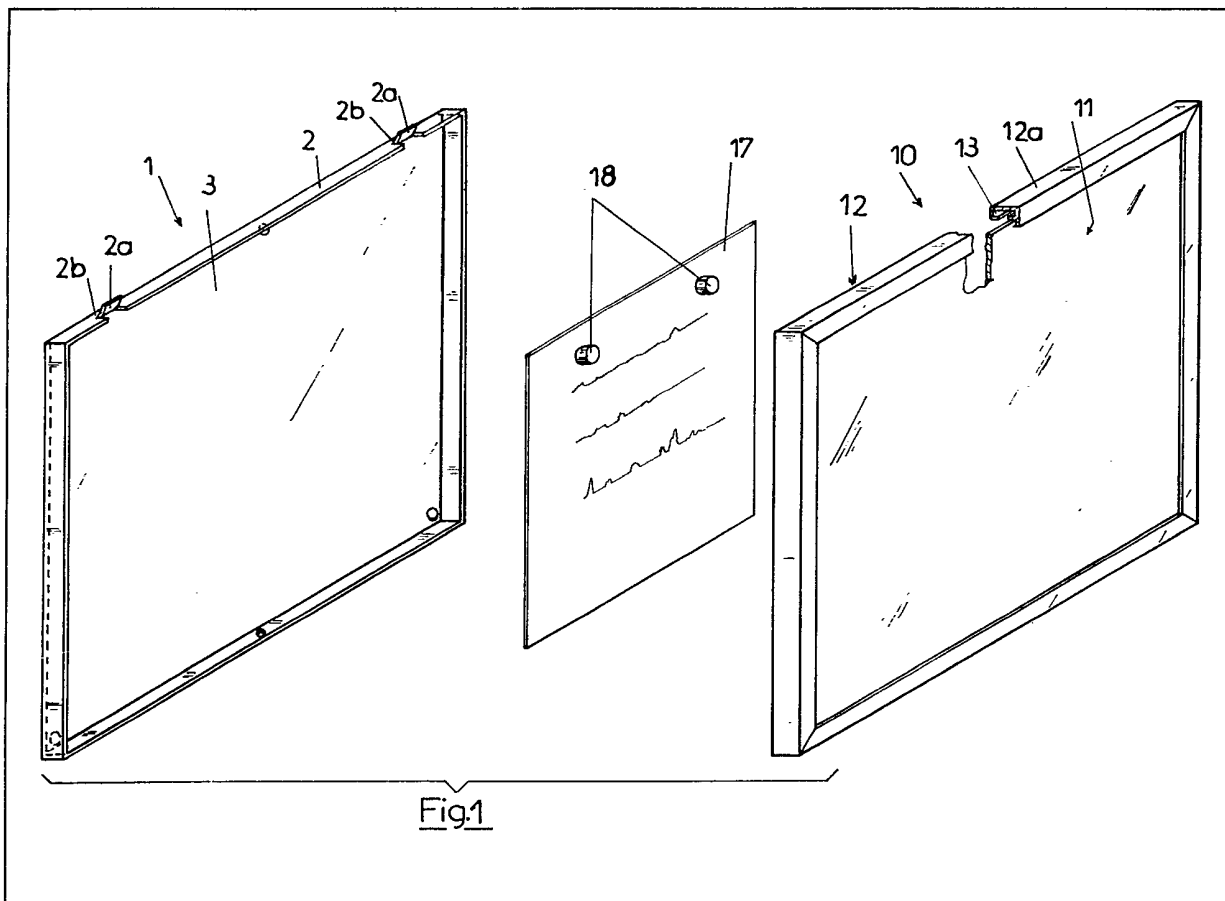

GB 2 106 691 A

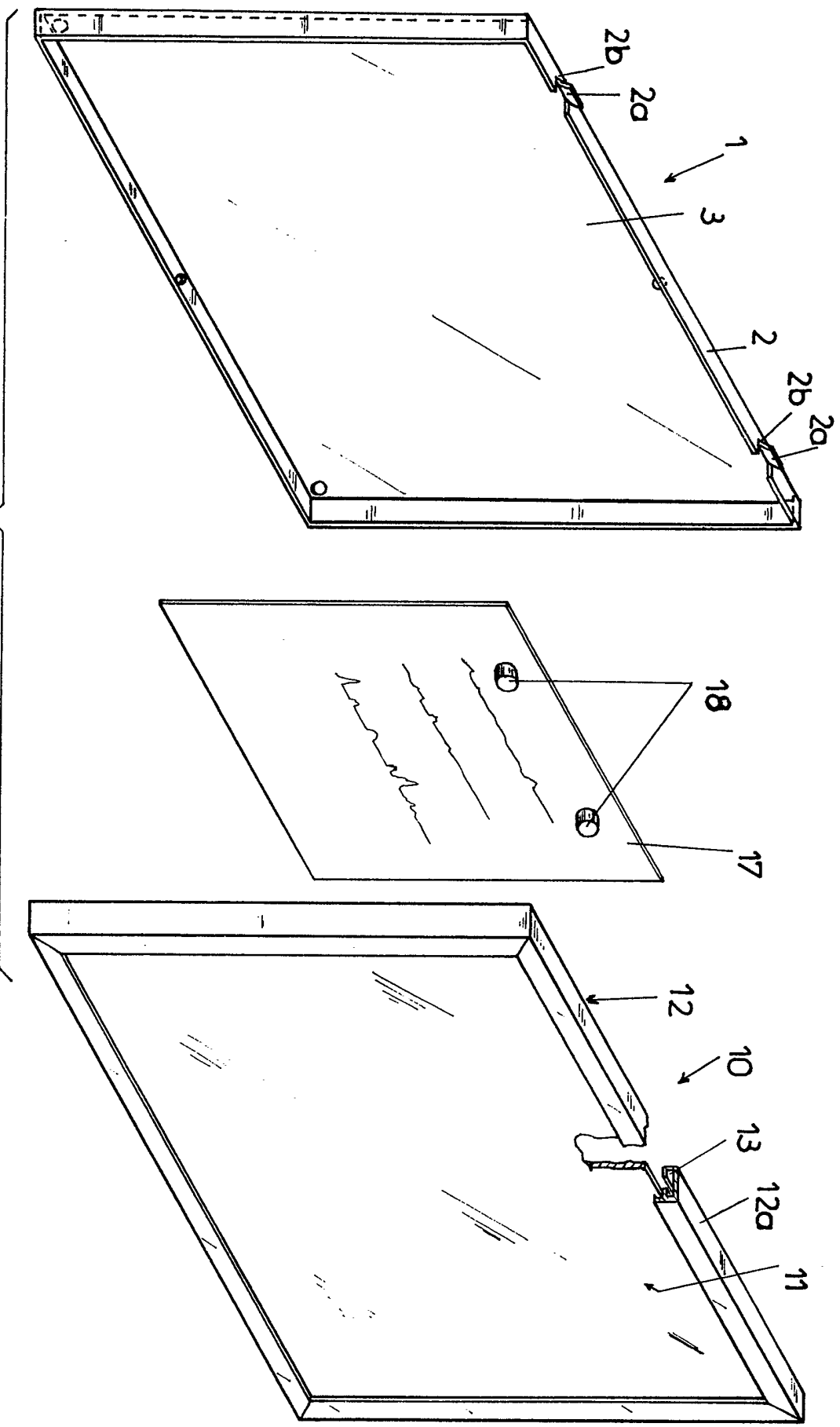
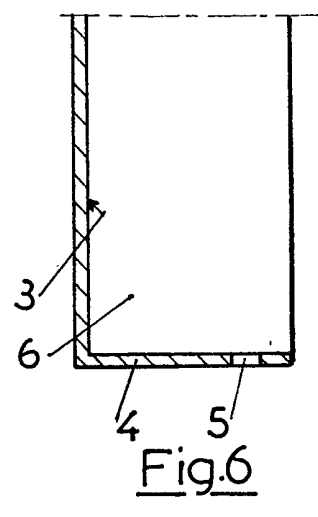
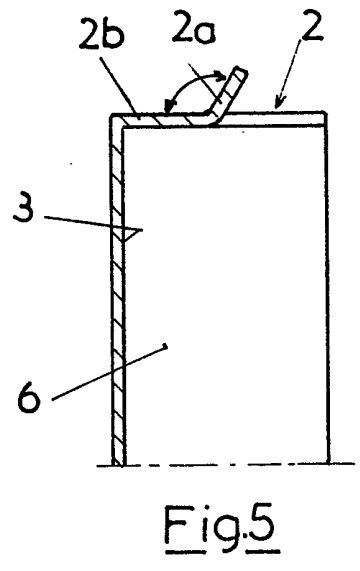
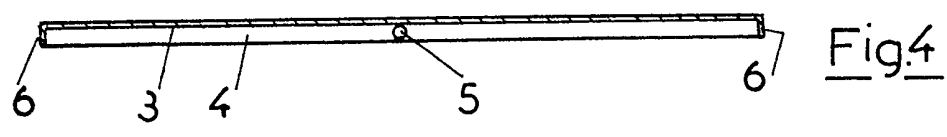
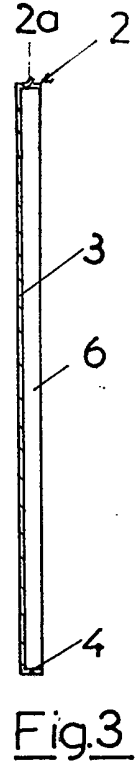
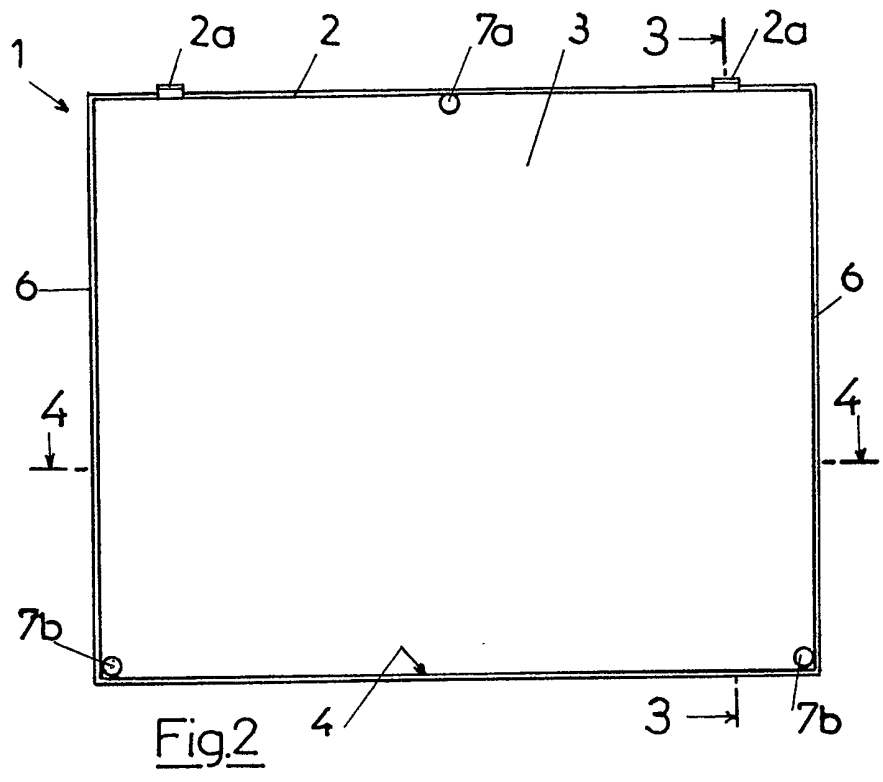

Fig. 1



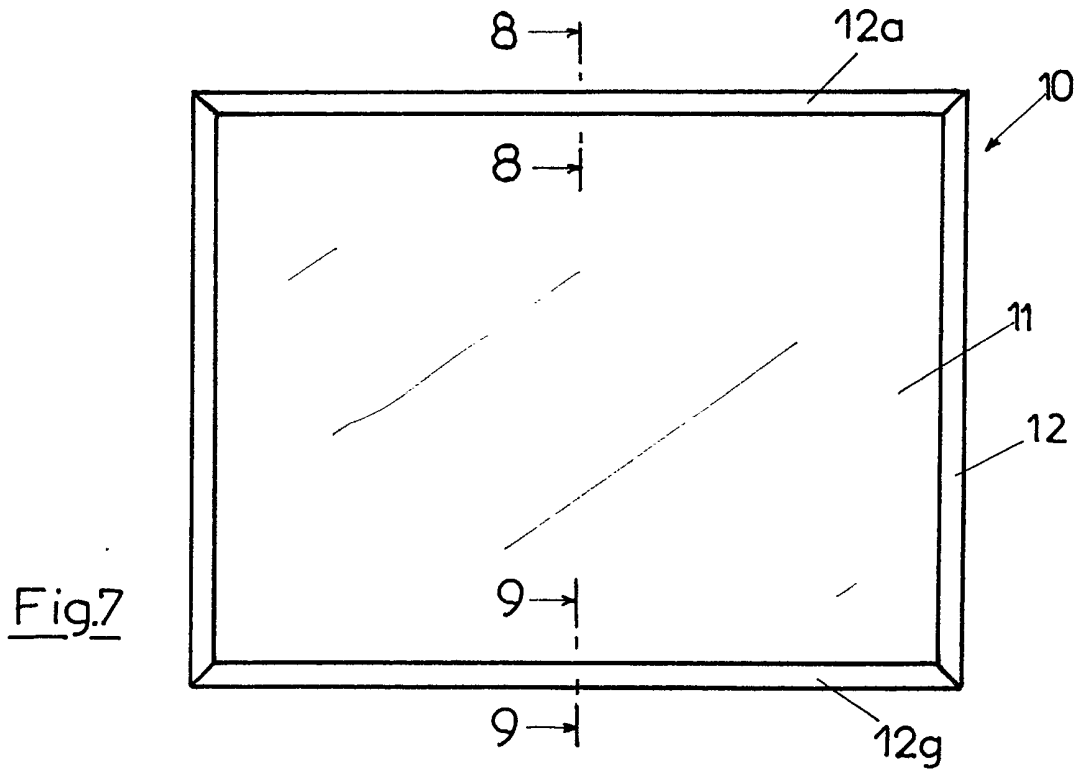

Fig. 7

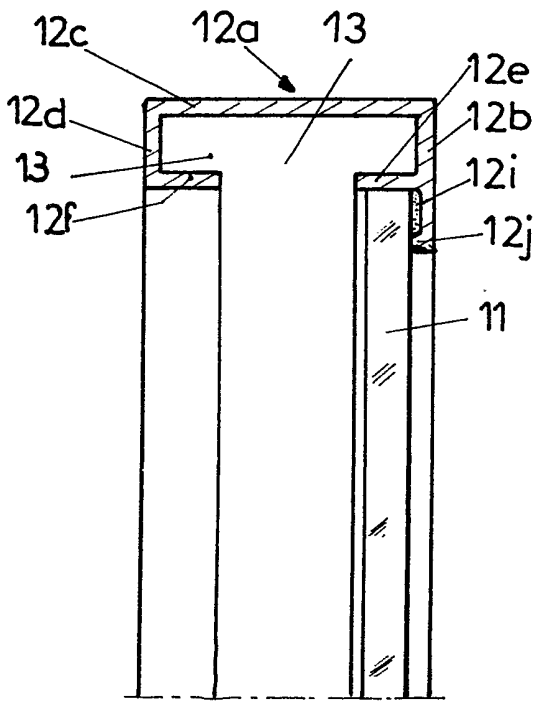

Fig. 8

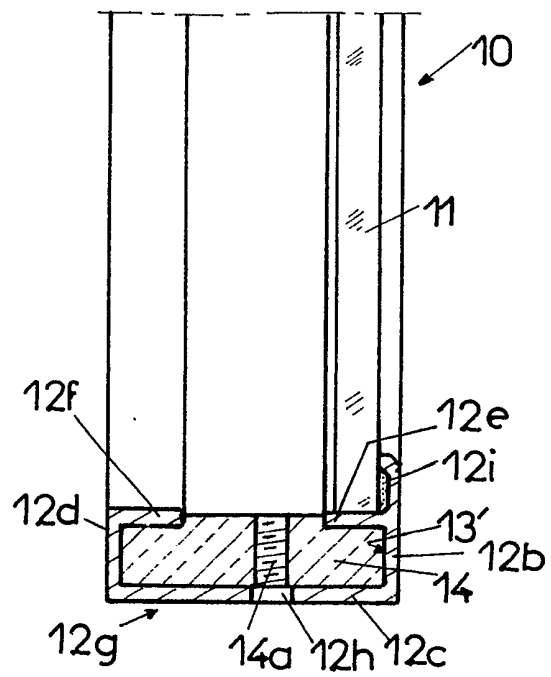

Fig. 9

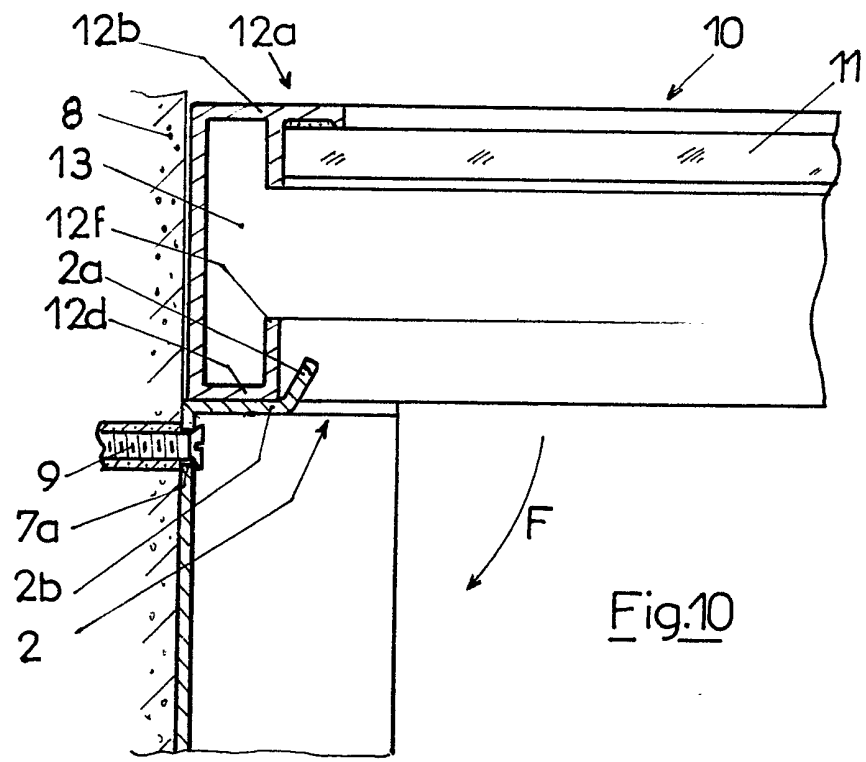

Fig.10

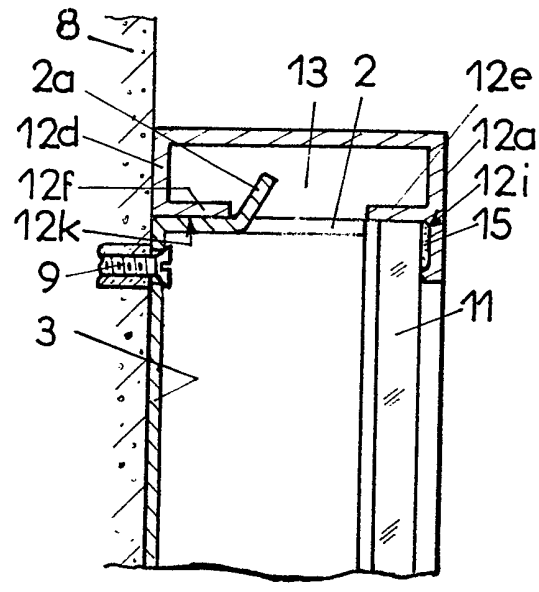

Fig.11

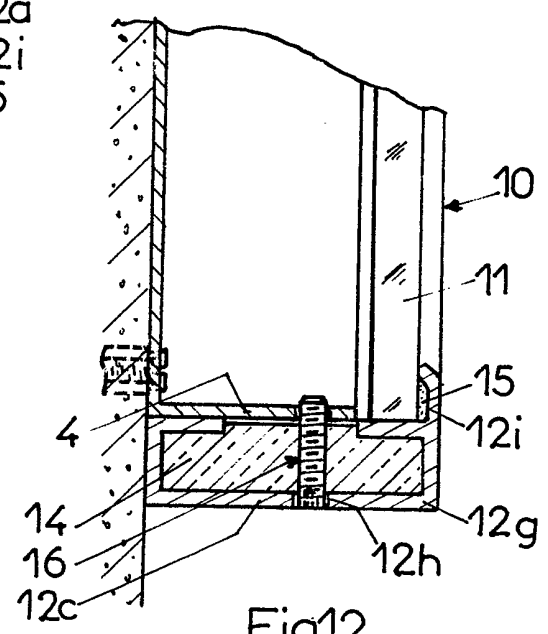

Fig.12

SPECIFICATION

Notice show case

5 The present invention relates to a notice show case of the kind comprising a first panel intended to be fixed on a wall or other vertical partition and to receive, on its exposed face, the sheets or documents to be displayed, and a second transparent protection panel pivoted on the first.

10 The known notice show cases comprise a notice panel provided with a frame permitting it to be fixed to a wall and made fast with the said panel by screwing, riveting, adhesive or other means, and a protection glass likewise provided with a frame and pivoted laterally on a vertical side of the notice panel by means of hinges.

15 The frames of the notice panel and of the protection glass are most often made of aluminium, whilst the said notice panel is generally made of compressed fibre or of lacquered steel. These notice show cases have the inconvenience of being quite inconvenient, because their manufacture requires numerous components and necessitates a large number of assembly operations.

20 The object of the present invention is thus to provide an economical notice show case comprising a number of components which is reduced as much as possible and necessitating a minimum of operations of assembly.

25 According to the invention, this object is achieved by a notice display case comprising a metallic display case comprising a metallic panel of which at least the upper side is rebated towards the front over at least a part of its length and of which the front edge is turned towards the exterior over at least a portion of its length, a bearing face forming an angle with the turned portion or portions of the said front edge being formed behind this latter or these latter, and a glass provided with a frame the upper side of which comprises at least one throat disposed to the rear of the said glass for the housing of the turned portion or portions of the said rebated upper side of the panel.

30 By this construction, the framed glass rests by the upper side of its frame on the rebated upper side of the panel, and the turned portion or portions of the said side housed in the throat of the said upper side of the frame of the glass assure the coupling of this latter with the said rebated upper side of the panel, whilst fulfilling the functions of hinges and means of retention.

35 The notice show case presents the advantage of being constructed with a minimum of components, of necessitating a very small number of operations of assembly and, consequently, of being able to be manufactured in a very economical manner. On the other hand, thanks to the method of pivoting and of coupling used, the peripheral surface of the notice show case is made free of any sharp parts, by reason of the absence of hinges or other apparent means of fixation.

40 These characteristics and advantages will appear from the following description and from the accompanying drawings in which:

Figure 1 is a perspective view, with partial sectioning, of a notice show case seen in separated condition;

Figure 2 is a front view of the display panel of the notice show case;

Figure 3 is a view in section along the line 3-3 of *Figure 2*;

Figure 4 is a view in section along the line 4-4 of *Figure 2*;

75 *Figure 5* is a detail view, on a larger scale and in vertical section of the upper part of the display panel;

Figure 6 is a detail view, to a larger scale and in axial vertical section, of the lower part of the said panel;

Figure 7 is a front view of the framed protection glass.

Figure 8 is a detail view, to a larger scale and in vertical section, of the upper part of this frame glass, taken on the line 8-8 of *Figure 7*;

Figure 9 is a detail view, to a larger scale and in vertical axial section, of the lower part of the frame glass, taken on the line 9-9 of *Figure 7*;

Figure 10 is a partial view, in vertical section, showing the upper part of the notice show case in open position;

Figure 11 is a partial view, in vertical section, illustrating the upper part of the show case in closed position;

Figure 12 is a partial view, in vertical axial section, of the lower part of the notice show case in closed position.

Reference is now made to the drawings for a description of an example of a preferred but in no way limiting construction of the notice show case.

The show case comprises a display panel 1 and a framed protection glass 10 provided with pivoting means and closing means.

The display panel is made of metal and, for example, of lacquered steel. It has a quadrangular shape, preferably rectangular. The upper side 2 of this panel is rebated or bent towards the front on at least a part of its length, and, preferably, on the whole of its length. The rebated upper side 2 forming an angle of 90° with the base or display surface 3 of the panel. The front edge of the upper rebated side 2 is bent or turned towards the exterior or upwardly, over at least a portion of its length. For example, and as illustrated in the drawings, two portions 2a of identical length of the front edge of the bent upper side 2 are turned towards the exterior, in such a manner as to constitute two tongues equidistant from the centre of the panel.

A horizontal bearing surface 2b is provided to the rear of the line of bending of the tongues or upturned portions 2a of the front edge of the rebated upper side 2. This bearing face 2b forms with the said up-turned portions 2a an obtuse angle β having, for example, a value of the order of 120°, these returned portions having a position inclined with respect to the base or display surface 3 of the panel. In an advantageous manner, the lower side 4 of the display panel 1 is likewise rebated or bent towards the front over at least a portion of its length, and preferably, over the whole of its length. The bent

lower side 4 forms, with the display surface of the panel, an angle of 90°. The rebated lower edge 4 comprises, preferably in its centre, a hole 5 the purpose of which will be explained later herein.

5 The lateral sides or vertical sides 6 of the panel 1 are likewise, in a preferred manner, rebated or bent towards the front over at least their greater portion and, preferably, over the whole of their height, the rebated lateral sides 6 forming, with the base or
10 display surface 3 of the said panel, an angle of 90°.
A fixing hole 7a is formed in the base 3 of the panel, in the proximity of the rebated upper edge 2 and in the vertical central axis of the panel, and the base 3 comprises two other fixing holes 7b disposed
15 in the proximity of the rebated lower edge 4, each of these latter being situated in the vicinity of a corner of the base. The disposition of the three holes 7a, 7b facilitates the positioning of the display panel, on a wall 8 or other vertical partition. In effect, during the
20 positioning of the panel, this latter is first of all suspended with freedom of pivoting in two directions, by means of a screw 9 passing through the upper hole 7a and not fully tightened. It is then easy to position the panel and to mark the position of
25 plugs or pegs for the reception of lower fixing screws, through the holes 7b. By pivoting the panel in one direction and then the other, it is then possible to implant the plugs or pegs in the wall, without removing the suspended panel.

30 The framed protection glass 10 is composed of a sheet 11 of transparent material (glass or transparent plastics material) and of a frame 12 made for example with the aid of aluminium sections. According to the invention, the horizontal upper side or
35 element 12a of the frame comprises, at the rear of the glass 11, at least one recess 13 for the housing of the up-turned or bent portion or portions 2a of the rebated upper side 2 of the panel 1. This recess is advantageously constituted by a recess which is
40 presented by the sections forming the frame 12. The sections used for the manufacture of the frame 12 comprise, for example and as is shown particularly in Figures 8 and 9, a front facing 12b assembled, by a transverse wall 12c to a rear facing 12d of less width.
45 The recess 13 is constituted by the space between the front and rear facings 12b and 12d, the entrance of the said recess being bounded by the ribs 12e and 12f placed opposite to each other and respectively integral with the front and rear facings, these ribs
50 being orientated in the direction of the interior of the section.

The horizontal lower element 12g of the frame 12 is provided, at its centre, with a nut 14 made of flexible material such as plastics material and
55 housed in the recess 13' of the section constituting the lower element.

The threading 14a of this nut intended to receive a closing screw is aligned with a hole 12h formed in the cross wall 12c of the lower section 12g. The nut
60 14 and its locking screw constitute, with the hole 5 formed in the rebated lower edge 4 of the panel 1, the means of locking of the show case in closed position.

The frame constituted by the rebated or bent sides
65 2, 4 and 6 of the display panel 1 has, externally,

dimensions which are substantially equal to or a little less than, the internal dimensions of the frame 12, in such a manner as to be able to be enclosed in this latter without excessive play.

70 The glass 11 is glued, for example by means of silicone glues, against the internal face of the forward facing 12b of the frame 12. For this purpose, the sections constituting the frame comprise a recess 12i disposed at the rear of their front facing.
75 This recess 12i is bounded by the rib 12e and by a second rib 12j parallel to the said rib 12e. The rib 12j is integral with the internal edge of the front facing 12b and directed towards the rear.

The rib 12j has a height which is less than that of
80 the rib 12e.

The recess 12i formed at the rear of the front facing of the frame 12 permits the introduction of a ribbon or layer of glue 15 of desired thickness for obtaining an efficacious glueing of the glass and the
85 frame, in spite of the large difference of the coefficients of expansion of the materials of which the glass and the frame are manufactured.

In the position of closing (Figures 11 and 12) the frame constituted by the bent sides 2, 4 and 6 of the
90 display panel fixed against the wall 8 is housed in the frame 12 of the protection glass 10. In this position, the upper element 12a of the frame 12 rests by means of the plane surface 12k constituted by the internal edge of the rear facing 12d and by the
95 internal face of the rib 12f, on the upper rebated side 2 of the display panel 1, and, more precisely, on the bearing face 2b formed at the rear of the tongues or bent portions 2a. The bearing face 12k of the upper element 12a of the frame 12 and the bearing face 2b
100 of the display panel 1 have equal or substantially equal widths. The rear facing 12d of the frame is disposed opposite to the wall 8 and the bent tongues or portions 2a prevent all movement forwardly of the upper part of the framed protection glass 10. On the
105 other hand, a screw 16 threaded into the nut 14 and passing through the hole 5 formed in the bent lower edge 4 of the panel 1 prevents all displacement forwardly of the lower part of the framed protection glass which is thus locked on the panel.

110 To open the notice display case, it is sufficient to unscrew the screw to withdraw it from the hole 5 and to pull, whilst lifting it, the lower part of the framed protection glass. During this movement, the upper element 12a of the frame 12 pivots and slides on the
115 upper surfaces of the rebated side 2 of the panel 1 and, notably, on the tongues 2a the inclined position of which permits and facilitates this pivoting.

The framed protection glass 10 can be simply lifted or completely disengaged from the display
120 panel 1 whilst one proceeds with the placing up of the documents or sheets of information 17 retained, in known manner against the panel by means of magnetic elements or drawing pins 18.

The framed glass can be rapidly and easily
125 replaced by placing the upper element 12a of the frame 12 on the top of the display panel 1, as illustrated in Figure 10, and by then causing it to pivot downwardly, according to the arrow F. It will be seen that, during this replacing, the wall 8 serves
130 as a stop member, and that during the pivoting

downwardly of the frame protection glass, the rebated lateral sides 6 of the display panel permit the centering and guiding of the frame 12.

5 CLAIMS

1. Notice show case, of the kind comprising a display panel and a glass provided with a frame, the display panel being preferably made of metal so as to permit the placing up of sheets of information supported by means of magnetic elements or drawing pins, characterised in that the display panel comprises an upper side rebated or bent forwardly over at least a portion of its length and of which the front edge is turned or bent rowards the exterior over at least a portion of its length such that a bearing face forming an angle with the up-turned portion or portions of the front edge is formed behind the upturned portion or portions, and in that an upper element of the frame or the framed protection glass comprises at least one recess disposed behind the glass for housing the up-turned portion or portions of the rebated upper side of the panel.

2. Notice show case, according to claim 1, wherein the up-turned or bent portion or portions of the front edge of the rebated upper side of the panel forms or form, with the bearing face provided behind the said turned portion or portions, an obtuse angle.

3. Notice show case, according to either of claims 1 and 2, wherein the display panel comprises a lower side rebated or bent forwardly over at least a portion of its length.

4. Notice show case, according to any one of claims 1 to 3, wherein the display panel comprises lateral or vertical sides rebated or bent forwardly over at least their upper part.

5. Notice show case, according to claim 4, wherein the frame constituted by the rebated sides of the display panel has external dimensions which are slightly less than the internal dimensions of the frame of the framed protection glass so as to be able to enter thereinto without excessive play.

6. Notice show case, according to either of claims 1 and 2, wherein the bearing face of the upper element of the frame of the frame protection glass has a width equal to or substantially equal to the width of the bearing face formed behind the up-turned portion or portions of the rebated upper edge of the display panel.

7. Notice show case, according to any one of claims 1 to 5, wherein the lower edge of the display panel and the lower element of the frame of the framed glass are provided with complementary means for locking the show case in closed position.

8. Notice show case, according to claim 7, characterised in that the said locking means comprise a hole formed in the lower bent side of the panel, preferably in its centre, and a nut of flexible material housing in a recess of the lower element of the frame of the framed glass, the threading of said nut being aligned with a hole formed in the connecting wall of the lower element, and a screw screwed into the nut and passing through the hole which is presented by

the bent lower side of the panel, permitting to lock the frame glass on the panel.

9. Notice show case, according to claim 1, in which the framed protection glass comprises a glass assembled by glueing to a frame, characterised in that a layer or strip of glue is disposed in a recess formed in the rear surface of the front facing of the frame.

10. Notice show case, according to claim 1, wherein the base of the display panel comprises three fixing holes, a first of said holes being disposed in the proximity of the upper edge and in the vertical central axis of the panel, and two other holes each being situated in the vicinity of a corner of the base, in the proximity of the lower edge of the panel.

11. Notice show case substantially as described herein with reference to the accompanying drawings.

Printed for Her Majesty's Stationery Office, by Croydon Printing Company Limited, Croydon, Surrey, 1983.
Published by The Patent Office, 25 Southampton Buildings, London, WC2A 1AY, from which copies may be obtained.