



- (51) International Patent Classification:
G02F 1/1343 (2006.01) G02F 1/155 (2006.01)
- (21) International Application Number:
PCT/US2016/014891
- (22) International Filing Date:
26 January 2016 (26.01.2016)
- (25) Filing Language: English
- (26) Publication Language: English
- (30) Priority Data:
62/113,272 6 February 2015 (06.02.2015) US
- (71) Applicant: PROTEQ TECHNOLOGIES LLC [US/US];
1000 N. West Street, Suite 1200, Wilmington, DC 19801 (US).
- (74) Agent: TREYZ, G., Victor; Treyz Law Group, 870 Market Street, Suite 984, San Francisco, CA 94102 (US).

- (81) Designated States (unless otherwise indicated, for every kind of national protection available): AT, AU, BG, BH, BR, CA, CH, CN, CO, DE, EC, ES, FI, GB, HR, HU, ID, IL, IN, IS, JP, KR, LU, LY, MA, MN, MX, MY, NA, NO, NZ, PE, PG, PH, PL, QA, RO, RS, RW, SD, SE, SG, SM, SV, SY, TN, US, VC, ZA.
- (84) Designated States (unless otherwise indicated, for every kind of regional protection available): ARIPO (BW, GH, GM, KE, LR, LS, MW, MZ, NA, RW, SD, SL, ST, SZ, TZ, UG, ZM, ZW), European (AL, AT, BE, BG, CH, CY, CZ, DE, DK, EE, ES, FI, FR, GB, GR, HR, HU, IE, IS, IT, LT, LU, LV, MC, MK, MT, NL, NO, PL, PT, RO, RS, SE, SI, SK, SM, TR).

Published:
— without international search report and to be republished upon receipt of that report (Rule 48.2(g))

(54) Title: ELECTROCHROMIC DEVICES

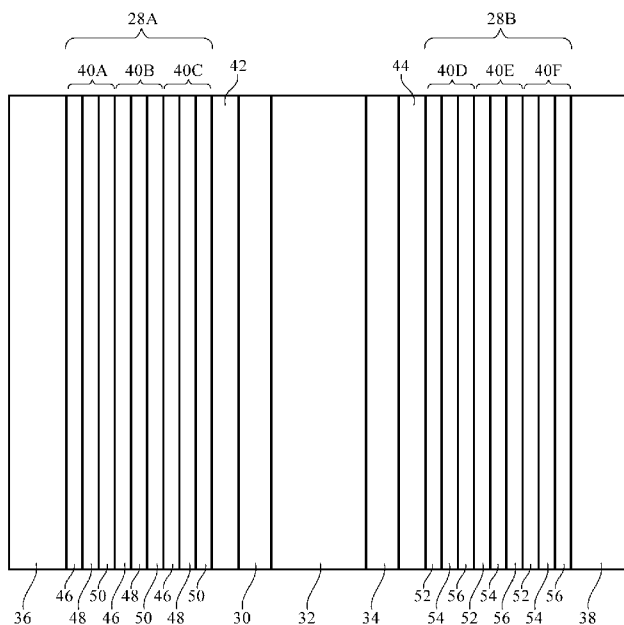

(57) **Abstract:** Conductive transparent electrodes may be formed from multilayer structures. The multilayer structures may include layers on a substrate. Each layer may include a seed layer, a metal layer on the seed layer, and a protective layer on the metal layer. The protective layer may be an oxide. The conductive transparent electrodes may pass visible light and block infrared light. An electrochromatic device may be formed from an electrolyte sandwiched between first and second layers of electrochromic material. The electrodes may be formed adjacent to the first and second layer of electrochromic material. A thin-film heater may be used to heat the electrochromic device to speed ion diffusion and chemical reaction rates, thereby enhancing electrochromatic device switching speeds. The thin-film heater may be controlled based on feedback from a light transmission sensor that is monitoring the transmission level of the electrochromic device.

FIG. 5

Electrochromic Devices

This application claims priority to U.S. provisional patent application No. 62/113,272, filed February 6, 2015, which is hereby incorporated by reference herein in its entirety.

Background

[0001] This relates generally to variable light transmission devices, and, more particularly, to electrochromic devices.

[0002] Mechanical shutters and electronic shutters have been used to control the transmission of light. For example, movable mechanical sunshades have been used to control the amount of light that passes through the windows of a building or vehicle. Electrochromic devices have also been used to control the amount of light that passes through windows. Electrochromic devices exhibit light transmission values that can be varied as a function of applied voltage. This allows electronic signals to be used to vary light transmission in place of movement of mechanical systems.

[0003] It can be challenging to form an electrochromic device. Some electrochromic devices have conducting oxide electrodes that exhibit high sheet resistance. This may cause an electrochromic device to exhibit a slow and non-uniform change in light transmission. Chemical diffusion processes can also limit switching speed. Light transmission is often lower than desired.

[0004] It would therefore be desirable to be able to provide improved devices such as electrochromic devices.

Summary

[0005] Conductive transparent electrodes may be formed from multilayer structures. The multilayer structures may include a stack of layers on a substrate. Each layer in the stack may include a seed layer, a metal layer on the seed layer, and a protective layer on the metal layer. The seed layer may be a crystalline oxide such as zinc oxide. The metal layer may be a crystalline metal layer such as a silver layer. The protective layer may be an oxide such as titanium oxide. The conductive transparent electrodes may pass visible light and block infrared light and may exhibit low resistivity and high visible light transmission.

[0006] An electrochromatic device may be formed from an electrolyte sandwiched between first and second layers of electrochromic material. The electrodes may be formed adjacent to the first and second layer of electrochromic material. The first and second layers of electrochromic material may be Li doped NiO and WO₃ layers or other suitable layers. Application of electric signals to the electrochromatic device may cause Li⁺ migration between the NiO and WO₃ layers, thereby adjusting the transmission of the electrochromic device.

[0007] A thin-film heater may be used to heat the electrochromic device to enhance ion diffusion and chemical reaction rates, thereby increasing electrochromatic device switching speeds. The thin-film heater may be controlled based on feedback from a light transmission sensor that monitors the transmission level of the electrochromic device.

[0008] The electrochromic device may be used in windows in buildings, vehicles, containers, or other structures. The conductive transparent electrodes may be used in the electrochromic device and in other devices such as displays and touch sensors.

Brief Description of the Drawings

[0009] FIG. 1 is a schematic diagram of an illustrative system that includes a variable light transmission device such as an electrochromic device in accordance with an embodiment.

[0010] FIG. 2 is a cross-sectional side view of an illustrative system with an electrochromic device that serves as an interface between an interior portion of the system and the exterior environment surrounding the system in accordance with an embodiment.

[0011] FIG. 3 is a cross-sectional side view of an illustrative electrochromic device in accordance with an embodiment.

[0012] FIG. 4 is an illustrative transmission spectrum for an electrochromic device or other device formed using electrodes in accordance with an embodiment.

[0013] FIG. 5 is a cross-sectional side view of an illustrative electrochromic device with electrodes formed in accordance with an embodiment.

[0014] FIG. 6 is a side view of an illustrative dynamically controlled heating system for facilitating rapid operation of an electrochromic device in accordance with an embodiment.

[0015] FIG. 7 is a graph in which an illustrative time-varying target transmission for an electrochromic device has been plotted as a function of time in accordance with an embodiment.

[0016] FIG. 8 is a graph in which the transmission of the electrochromic device of FIG. 7 has been plotted as a function of time in accordance with an embodiment.

[0017] FIG. 9 is a graph in which the temperature of the electrochromic device of FIG. 7 has been plotted as a function of time in accordance of the present invention.

[0018] FIG. 10 is a diagram showing how an electrode layer may be formed as part of a display or touch sensor in accordance with an embodiment.

[0019] FIG. 11 is a diagram of an illustrative organic light-emitting diode display with an electrode in accordance with an embodiment.

[0020] FIG. 12 is a diagram of an illustrative liquid crystal display with an electrode in accordance with an embodiment.

[0021] FIG. 13 is a top view of an illustrative camera in which an electrochromic device with segmented electrodes has been used to implement an adjustable aperture in accordance with an embodiment.

Detailed Description

[0022] Systems such as buildings, vehicles, electronic equipment with light producing and light sensitive components (e.g., electronic devices such as computers, cellular telephones, and other portable electronic equipment), and other systems may use electrochromic devices and other structures that include transparent electrodes. Electrochromic device performance and the performance of other systems with transparent electrodes can be enhanced by forming the electrodes using a high-transmission, low resistivity structure. High light transmission can boost optical efficiency. Low resistance can enhance electrochromic device switching speed and other device performance parameters. The transparent electrodes may block infrared light and may be used as windows in buildings, vehicles, containers, and other structures.

[0023] An illustrative system of the type that may be provided with an electrochromic device or other device with transparent electrodes is shown in FIG. 1. System 10 of FIG. 1 may be an electronic device such as a computer or other equipment with a display, touch sensor, or other component that includes one or more transparent electrodes, may be an electronic device such as a computer or other electronic equipment having a camera or other component that senses light through structures having one or more transparent electrodes, may be an automobile, truck, airplane, or other vehicle that has windows through which it is desired to control light transmission, may be a building with windows through which it is desired to control light transmission, or may be other system that includes an electrochromic device or other equipment with transparent electrodes.

[0024] As shown in FIG. 1, system 10 may include control circuitry 12. Control circuitry 12 may include storage and processing circuitry for supporting the operation of device 10. The storage and processing circuitry may include storage such as hard disk drive storage, nonvolatile memory (e.g., flash memory or other electrically-programmable-read-only memory configured to form a solid state drive), volatile memory (e.g., static or dynamic random-access-memory), etc. Processing circuitry in control circuitry 12 may be used to control the operation of device 10. The processing circuitry may be based on one or more microprocessors, microcontrollers, digital signal processors, baseband processors, power management units, audio chips, application specific integrated circuits, etc.

[0025] In some configurations (e.g., configurations in which system 10 is an electronic

device such as a computer or other electronic equipment), system 10 may include input-output devices 14 that allow data to be supplied to system 10 and that allow data to be provided from system 10 to external systems. Input-output devices 14 may include buttons, joysticks, scrolling wheels, touch pads, key pads, keyboards, microphones, speakers, tone generators, vibrators, cameras, sensors, light-emitting diodes and other status indicators, data ports, etc. A user can control the operation of this type of system by supplying commands through input-output devices 14 and may receive status information and other output from the system using the output resources of input-output devices 14. If desired, input-output devices 14 may include one or more displays (e.g., organic light-emitting diode displays and other displays with arrays of light-emitting diodes, liquid crystal displays, electrophoretic displays, etc.). Displays may be touch screen displays that includes a touch sensor for gathering touch input from a user or may be insensitive to touch. A touch sensor for a display may be based on an array of capacitive touch sensor electrodes, acoustic touch sensor structures, resistive touch components, force-based touch sensor structures, a light-based touch sensor, or other suitable touch sensor arrangements.

[0026] The optional input-output devices of system 10 (e.g., a display, touch sensor array, etc.) may contain transparent electrodes. System 10 may also have one or more variable light-transmission devices such as electrochromic device 16 that includes transparent electrodes. Electrochromic device 16 may exhibit an electronically controlled light transmission characteristic based on the electrochromism principle. Switching speed in electrochromic device 16 may, if desired, be enhanced by dynamically heating electrochromic device 16 and thereby enhancing ion diffusion and chemical reaction rates in the electrochromic device.

[0027] In some configurations, transparent electrodes may be embedded within the equipment of system 10. For example, transparent electrodes may be formed within a display, a touch sensor, or other device that uses transparent conductive layers. In other configurations, such as a building or vehicle, transparent electrodes may be formed as part of an electrochromic window. A cross-sectional side view of this type of system is shown in FIG. 2. As shown in FIG. 2, system 10 may include structures such as structures 20 that separate system exterior 24 from system interior 22. One or more electrochromic devices such as electrochromic device 16 may serve as windows in structures 20. Structures 20 may form walls in a building, the body of a vehicle, walls in a container, or other support

structures for the electrochromic devices. Because the electrochromic devices are mounted in openings in structures 20 and separate interior 22 from exterior 24, electrochromic devices in this type of arrangement are sometimes referred to as electrochromic windows. Examples of electrochromic windows that may incorporate an electrochromic device include office building windows, windows in a home, vehicle windows such as a sunroof window in an automobile or truck, side and rear vehicle windows in an automobile or truck, or a strip-shaped part of a window such as an upper strip along the front window in an automobile or truck, windows in vehicles such as boats or airplanes, and viewing windows in a box-shaped enclosure or other container. Windows such as these (e.g., windows in a vehicle) may, if desired, move relative to structures 20. If desired, electrochromic devices such as electrochromic device 16 of FIG. 2 may be incorporated into other types of systems. The arrangement of FIG. 2 is merely illustrative.

[0028] Electrochromic device 16 may be controlled in real time to control the transmission of light 26 between exterior 24 and interior 22. For example, when it is desired to dim a room in a building, the visible light transmission of electrochromic device 16 may be decreased to decrease the amount of light 26 that is passing from exterior 24 to interior 22. When it is desired to let more light pass into interior 22, electrochromic device 16 may be adjusted to increase the visible light transmission of electrochromic device 16.

[0029] Electrochromic device 16 may be configured to exhibit low amounts of light transmission at infrared wavelengths. This type of infrared light-blocking configuration may help avoid excessive heat transmission to interior 22. For example, infrared light components of solar radiation may be blocked by electrochromic device 16 rather than being passed into interior 22. This may help reduce solar heat build up in the interior of a building, the interior of a vehicle, or the interior of a container or other structure.

[0030] A cross-sectional side view of an illustrative electrochromic device is shown in FIG. 3. As shown in FIG. 3, electrochromic device 16 may have electrodes 28 such as electrode 28A and electrode 28B. Electrodes 28A and 28B and device 16 may extend along lateral dimensions X and Y that lie perpendicular to dimension Z. Electrode 28A is adjacent to electrochromic layer 30 and electrode 28B is adjacent to electrochromic layer 34. A current may be applied to electrochromic layers 30, 32, and 34 to either darken (color) or lighten (discolor) device 16. Layers 30, 32, and 34 may be, for example, materials that support an oxidation-reduction reaction in which the polarity of the applied electrical signal determines

whether device 16 is darkened or lightened. By increasing or decreasing the transmission of device 16, the amount of light 26 that passes through device 16 can be controlled.

[0031] With one illustrative configuration, electrochromic material 30 is a layer of Li_xNiO formed as a coating on electrode 28A, electrochromic material 34 is a layer of WO_3 formed as a coating on electrode 28B, and material 32 is a layer of a gel electrolyte such as LiNiOP that is interposed between the Li_xNiO and WO_3 layers. With this type of configuration, device 16 can be darkened or lightened by applying current through layers 30, 32, and 34 using electrodes 28A and 28B. The NiO material of layer 30 is brownish in color when undoped, but turns transparent when doped with Li. The WO_3 material of layer 34 is bluish in color when doped by Li, but turns transparent when not doped by Li. When it is desired to darken device 16, a positive voltage may be applied to electrode 28A relative to electrode 28B. This causes Li^+ ions to be injected into electrolyte layer 32 from layer 30 and causes Li^+ ions to form LiWO_3 complexes at the interface between layers 32 and 34, thereby coloring both layers 30 and 34 and darkening device 16. When it is desired to render device 16 transparent, a negative voltage may be applied to electrode 28A relative to electrode 28B. This causes Li^+ ions to be injected into layer 32 from layer 34, leaving behind undoped WO_3 in layer 34 and causes LiNiO complexes to form at the interface between layers 30 and 32, thereby discoloring both layers 30 and 34 and rendering device 16 transparent.

[0032] If desired, other electrochromic device chemistries may be used in device 16. For example, layer 30 may be formed from a material such as CrO or CoO instead of NiO , layer 34 may be formed from a material such as TiO or MoO instead of WO_3 , other inorganic materials may be used for layers 30, 32, and/or 34, organic materials may be used to form the electrochromic layers in device 16, etc.

[0033] The time required for device 16 to switch between colored and discolored states is sometimes referred to as the switching time for device 16. Switching speeds can be enhanced by rapidly delivering current to layers 30 and 34 and by enhancing ion diffusion and the speed with which the chemical reactions take place in layers 30, 32, and 34. Rapid current delivery and enhanced switching uniformity can be achieved by minimizing the resistance of electrodes 28.

[0034] Electrodes 28 may be formed from transparent conducting oxides such as indium tin oxide. An electrode formed from a layer of indium tin oxide may exhibit a sheet resistance of about 8-10 ohm/square. If desired, lower resistance electrodes may be formed using

multilayer structures. For example, a multilayer structure having one or more layers of a metal such as silver may be used in forming electrodes 28. This type of multilayer electrode structure may exhibit a sheet resistance of less than 8 ohm/square. For example, a multilayer electrode may exhibit a sheet resistance of about 1 ohm/square, 0.5-8 ohm/square, more than 0.2 ohm/square, less than 5 ohm/square, 0.1-3 ohm/square, less than 2 ohm/square, etc.

[0035] If desired, a multilayer electrode structure may be configured to exhibit more transmission at visible light wavelengths than at infrared wavelengths. This allows electrodes 28 to serve not only as low resistance electrochromic device electrodes, but also as infrared-light-blocking layers that help reduce solar heating in locations such as interior portion 22 of system 10 of FIG. 2.

[0036] An illustrative transmission spectrum for electrodes 28 that have been based on a multilayer construction of this type is shown in FIG. 4. As shown in FIG. 4, electrodes 28 (and an electrochromic device in which one electrode 28 or multiple electrodes 28 have been incorporated) may exhibit high transmission TR2 at visible (VIS) light wavelengths (e.g., 400-700 nm) and may exhibit low transmission TR1 (and high reflectivity) at infrared (IR) wavelengths (e.g., wavelengths above 700 nm, wavelengths from 700-3000 nm, wavelengths of 700-2000 nm, or other infrared wavelengths). The value of transmission TR2 over these ranges of IR wavelengths may be 60-100%, may be more than 60%, may be more than 70%, may be more than 80%, may be more than 85%, may be more than 90%, may be 90-100%, may be less than 99%, or may be any other suitable transmission level. The value of transmission TR1 may be less than 80%, less than 40%, less than 30%, less than 20%, less than 10%, less than 5%, more than 2%, or any other suitable transmission level.

[0037] An illustrative electrochromic device having multilayer electrodes of the type that may exhibit low sheet resistance and high infrared light blocking capabilities is shown in FIG. 5. As shown in FIG. 5, electrochromic device 16 may have electrochromic materials 30, 32, and 34 that are sandwiched between electrodes 28A and 28B. Electrode 28A is formed from layers deposited on transparent substrate 36. Electrode 28B is formed from layers deposited on transparent substrate 38. Substrates 36 and 38 may be clear glass, transparent plastic, sapphire, ceramic, or other transparent materials or structures containing two or more layers of these materials.

[0038] Electrode 28A may include a stack of one or more layers such as layers 40A, 40B, and 40C, each of which contains a thin metal layer such as a thin silver layer that provides

electrode 28 with conductivity. Electrode 28B may likewise have one or more layers such as layers 40D, 40E, and 40F that each contain a thin layer of silver or other metal. There are three of these layers on each electrode in the example of FIG. 5, but, in general, each electrode may have one or more layers such as layers 40A, 40B, 40C, 40D, 40E, and 40F. The compositions of the material and the thicknesses of the materials in layers 40A, 40B, 40C, 40D, 40E may be selected to provide electrodes 28 with a high visible light transmission and, if desired, a low infrared transmission (and high infrared reflection), as described in connection with FIG. 4.

[0039] During electrode fabrication, layers of material may be deposited on substrate 36 in sequence. Initially a crystalline seed layer such as layer 46 of layer 40A may be deposited. The seed layer may be formed from a crystalline oxide such as zinc oxide or other material that serves as a suitable base layer for subsequent crystalline silver deposition. Layer 46 may have a thickness of about 11 nm (10-15 nm, less than 15 nm, more than 10 nm, etc.) and may be deposited using sputter deposition or other suitable deposition techniques.

[0040] Metal layer 48 may be deposited on seed layer 46. Metal layer 48 may be formed from silver or other suitable metal and may have a thickness of about 10-20 nm, more than 10 nm, less than 20 nm, etc. Excessive thicknesses for layer 48 should be avoided to avoid creating excessive visible light absorption. At the same time, layer 48 should not be too thin so that electrodes 28 exhibit low sheet resistance. Sputter deposition techniques or other deposition techniques may be used when depositing layer 48.

[0041] Silver has the potential of becoming damaged when exposed to oxygen. The risk of damage will be elevated when the deposited silver has a rough surface morphology. By forming a thin layer, silver layer 48 may be crystalline and may exhibit a smooth surface morphology suitable for supporting the growth of additional smooth crystalline layers of material for electrode 28.

[0042] After depositing silver layer 48, a barrier film such as protective layer 50 of layer 40A may be deposited. Protective layer 50 may be a crystalline layer of titanium oxide (e.g., titanium dioxide) that exhibits a close lattice match to zinc oxide seed layer 46 and silver layer 48 and that serves to protect silver layer 48 from damage during subsequent layer deposition steps (e.g., when sputter depositing additional seed layers). Layer 50 is preferably deposited using a technique such as atomic layer deposition that allows layer 50 to be accurately deposited to a thickness of about 2 nm (e.g., about 10-20 atomic layers) without

damaging silver layer 48. Layer 50 may, for example, have a thickness of less than 3 nm, less than 5 nm, more than 1 nm, 1-5 nm, 1-3 nm, or other suitable thickness. If desired, other deposition techniques may be used (e.g., sputtering) and/or other materials may be used to form protective layer 50 (e.g., titanium, ZnAlO, SiO₂, etc.). An advantage of using titanium oxide rather than materials such as titanium is that transmission for electrode 28 may be enhanced (e.g., visible light transmission may be increased from about 70% to about 85-90%). Quantum mechanical tunneling may allow current to pass through thin dielectric layers in electrodes 28 such as an oxide protective layer.

[0043] After depositing protective layer 50 in layer 40A, the formation of layer 40A is complete. Subsequent layers (e.g., layers 40B and 40C) may be formed in the same way as layer 40A. First seed layer 46 is deposited on the previous protective layer 50. Metal layer 48 is then deposited, followed by another protective layer 50. The thickness of metal layer 48 may differ in different layers. For example, layer 48 may have a thickness of 11 nm in layer 40A, a thickness of 13 nm in layer 40B, and a thickness of 17 nm in layer 40C (as an example). Optical simulations have determined that this type of configuration with different metal layer thicknesses can help enhance visible light transmission. Other layer thicknesses may be used if desired. In addition to enhancing transmission through appropriate selection of layer thicknesses, visible light transmission may also be enhanced by plasmonic effects at the interface between the ZnO and Ag layers.

[0044] Following deposition of layers 40A, 40B, and 40C, layer 42 is deposited on layer 40C to finish formation of electrode 28A. In the illustrative configuration of FIG. 5, layer 42 is a ZnO layer, but other materials with an appropriate lattice constant may be used, if desired. After layer 42 has been deposited, NiO layer 30 may be deposited (e.g., to a thickness of 7 nm to 1 micron or other suitable thickness).

[0045] Electrode 28B may, if desired, be formed in the same way as electrode 28A. Layers 40F, 40E, and 40D may be deposited one after the other on substrate 38. In each of these layers, layer 56 is a ZnO layer or other seed layer such as one of layers 46, metal layer 54 is a silver layer or other metal layer such as one of layers 48, and protective layer 52 is a barrier film such as a titanium oxide layer or other layer such as one of layers 50. Layer 44 (e.g., a ZnO layer such as layer 42) may be deposited after depositing layer 40D. Electrochromic material layer 34 may be deposited on layer 44 and electrolyte layer 32 may be sandwiched between layers 30 and 34 to form electrochromic device 16.

[0046] The speed with which electrochromic device 16 can change transmission levels is in affected by the speed with which ions (e.g., Li⁺ ions) diffuse in layer 32 and the speed with which the ions chemically react. Ion diffusion and chemical reaction rates can be enhanced by heating device 16. For example, a thin-film heater may be placed in contact with device 16 or other structures to which heat is to be applied. Using a pulse-width-modulated signal or other controllable intensity drive signal, current can be applied to the thin-film heater. The current flowing through the thin-film heater can produce heat through ohmic heating. To enhance the resistance of heater 64, heater 64 may be formed from a serpentine strip of material. Heater 64 may also be formed from a blanket film. When the current is increased, more heat is produced. If desired, feedback may be used to help control the heating process. The thin-film heater may extend over all of device 16 (e.g., 100% of the surface area of device 16) or may extend over only part of the area of device 16 (e.g., less than 100% of the area of device 16, less than 50% of the area of device 16, 25-80% of the area of device 16, less than 80% of the area of device 10, more than 10% of the area of device 16, etc.).

[0047] An illustrative configuration for system 10 that includes thin-film heating capabilities is shown in FIG. 6. As shown in FIG. 6, system 10 may include thin-film heater 64. Thin-film heater 64 may be formed on one or more surfaces of electrochromic device 16 or other structure in system 10 that is to be heated. Examples of structures other than electrochromic device 16 that may be heated using thin-film heater 64 include mirrors in a home, office, vehicle, or other location and windows in a building, vehicle, container, or other environment. Windows and mirrors may be heated to de-ice these structures or to defog these structures (as examples).

[0048] Thin-film heater 64 may be formed from a transparent conductive material such as a transparent conducting oxide (e.g., indium tin oxide). For example, device 16 may have electrodes 28 that are formed from structures of the type described in connection with FIG. 5 and thin-film heater 64 may be formed from a layer of indium tin oxide or other material that is deposited as a coating on one of electrodes 28 (as an example). If desired, thin-film heater 64 may be formed from electrode structures of the type described in connection with electrodes 28 of FIG. 5.

[0049] Light source 74 may be a light-emitting diode or other light source that produces light 78. Light 78 may be, for example, visible light. Light sensor 76 may detect light 78. When the transmission of electrochromic device 16 is high, light 78 will pass through

electrochromic device 16 and thin-film heater 64. When the transmission of electrochromic device 16 is low, some or all of light 78 will be blocked. Control circuitry 12 may control the amount of light 78 that is produced by source 74 and may measure the amount of light 78 that is transmitted through device 16 and heater 64 using light sensor 76.

[0050] Control circuitry 12 may control the amount of heat that is produced by heater 64 by controlling the amount of current passing through path 60. Control circuitry 12 may, for example, apply heat to electrochromic device 16 whenever the state of electrochromic device 16 is being changed. The elevated temperature from the applied heat helps enhance the switching speed of device 16. Using feedback from the optical monitoring system (source 74 and sensor 76), control circuitry 12 can dynamically adjust the amount of heat that is being produced by heater 64. Control circuitry 12 may, for example, reduce the amount of heat that is being applied once the transmission exhibited by electrochromic device 16 is within a predetermined amount of a target transmission (transmission set-point) established by a user of system 10.

[0051] Control circuitry 12 may include components such as components 68, 70, and 72 for monitoring light transmission and controlling heater 64 accordingly. Component 68 may be a transimpedance amplifier that converts current signals from light sensor 76 into a signal voltage representative of the amount of light 78 that is detected by light sensor 76. Component 70 may be a proportional-integral-derivative controller. The proportional-integral-derivative controller may receive the output of the transimpedance amplifier at a first input and may receive a voltage representative of a user-defined light transmission setpoint for device 16 at a second input. The proportional-integral-derivative controller may produce a control signal that is based on the difference between the voltages at the first and second inputs. Component 72 may be a circuit such as a pulse width modulation (PWM) circuit that applies a current to heater 64 via path 60 that has a strength (e.g., a pulse width) based on the control signal received from the proportional-integral-derivative controller. With this type of scheme, heater 64 may rapidly elevate the temperature of device 16 whenever a user adjusts the transmission setting for device 16 and may shut down heater 64 as soon as optical feedback measurements made with light source 74 and light sensor 76 indicate that the desired transmission setpoint has been reached (or almost reached).

[0052] Consider, as an example, a scenario in which a user adjusts a light transmission setpoint (TRset). As shown by curve 80 in FIG. 7, TRset has a value of TH at times before

time t_1 . At time t_1 , the user lowers the setpoint to T_L .

[0053] At times before time t_1 , electrochromic device 16 exhibits a transmission T_R with a value of T_H in accordance with the established setpoint, as shown by curve 82 in FIG. 8. At time t_1 , in response to the adjustment of setpoint T_{Rset} to T_L , control circuitry 12 uses the pulse width modulation controller or other control circuitry to apply a heating current to heater 64. As shown by curve 84 in FIG. 9, this raises the temperature T of heater 64 to help enhance ion diffusion and chemical reaction rates in device 16, thereby enhancing the switching speed for device 16. While device 16 is switching, the transmission of device 16 is being monitored by measuring light 78 with light sensor 76. As soon as the measured value of transmission T_R reaches a value within a predetermined amount ΔT_R (e.g., a predetermined threshold amount, a predetermined fraction of the transmission setpoint, etc.) or has otherwise reached a value that is sufficiently close to the desired target transmission value, control circuitry 12 can reduce the heat being produced by heater 64. As a result, temperature T may drop at times after time t_2 , as shown in FIG. 9.

[0054] If desired, a conductive transparent electrode of the type used in forming electrodes 28A and 28B of FIG. 5 may be incorporated into a display, touch sensor, or other electronic component with transparent conductive structures. As shown in FIG. 10, a display or other input-output device 14 may have layers such as layers 88 and 92. Electrode 28 may be interposed among layers 88 and 92 and may be used in forming an array of elements 94 for the device. Electrode 28 may be, for example, a patterned transparent conductive electrode that is used in forming an array of capacitive touch sensor pads or other touch sensor electrodes (i.e., components 94 may be transparent conductive touch sensor electrodes).

[0055] If desired, the device of FIG. 10 may be a display and components 94 may be an array of pixels. In this type of configuration, pixels 94 may be organic light-emitting diode pixels, liquid crystal display pixels, electrophoretic display pixels, or other suitable display pixels. Layers 88 and 92 of display 14 may include substrate layers, inorganic layers, organic layers, dielectric layers, metal layers, and other display structures. Electrode 28 may be used to convey signals laterally within display 14 and may be interposed among the other layers of display 14 such as layers 88 and 92.

[0056] In the illustrative configuration of FIG. 11, multilayer electrode 28 has been used to form a cathode layer in an organic light-emitting diode display. As shown in FIG. 11, each pixel 94 of display 14 may include a light-emitting diode such as light-emitting diode 104.

Display 14 may have a substrate such as substrate 98. Thin-film transistor circuitry 100 (e.g., pixel circuits for controlling light-emitting diode 104) may be formed on substrate 98. Each diode 104 may have an anode and a cathode. Anode 106 may be coupled to a drive transistor in thin-film transistor circuitry 100. Anode 106 may be located in an opening formed within dielectric layer 102. Organic emissive material 108 may be used to generate light when current is applied between anode 106 and the cathode formed from electrode 28. Anode 106 may be formed from a conductive material such as metal. The cathode formed from electrode 28 may be formed from a blanket multilayer structure of the type described in connection with electrodes 28A and 28B of FIG. 5 (e.g., electrode 28 may be highly transparent and may exhibit a low sheet resistance).

[0057] In the illustrative configuration of FIG. 12, display 14 is a liquid crystal display. Display 14 has liquid crystal layer 124. Liquid crystal layer 124 may be sandwiched between color filter layer 126 and thin-film transistor layer 130. Color filter layer 126 may have an array of color filter elements that provide display 14 with the ability to display color images. Color filter layer 126, liquid crystal layer 124, and thin-film transistor layer 130 may be sandwiched between upper polarizer 134 and lower polarizer 132. A backlight unit may create backlight 136 that passes through display 14.

[0058] Thin-film transistor layer 130 may have a layer of thin-film transistor circuitry 116 on transparent substrate 114. Electrode 28 may be formed from a multilayer structure of the type described in connection with electrodes 28A and 28B of FIG. 5 and may serve as a common voltage (Vcom) electrode for display 14. Dielectric layer 120 may separate pixel electrode fingers 122 from Vcom layer 28. Layer 28 may exhibit high transmission and low sheet resistance, which can help enhance pixel switching speed and the efficiency with which display 14 allows backlight 136 to pass through pixels 94.

[0059] If desired, electrochromic device 16 may be used to form an adjustable opening for an electronic device. The adjustable opening may be, for example, a shutter that hides or reveals an optical component from view (e.g., a camera, a proximity sensor, an ambient light sensor, a status indicator light, a display, etc.). In this type of arrangement, electrochromic device 16 may have a single pair of electrodes. The shutter formed by device 16 may be open or closed by controlling the voltage across the signal pair of electrodes.

[0060] In some configurations, electrochromic device 16 may be provided with segmented electrodes that are individually adjustable. Consider, as an example, the use of

electrochromic device 16 to form an electronically adjustable camera aperture. An arrangement of this type is shown in the top view of device 16 in FIG. 13. As shown in FIG. 13, device 16 may have multiple individually controllable concentric electrodes such as first electrode 28-1, second electrode 28-2, and third electrode 28-3 (or more electrodes or fewer electrodes). Each of these electrodes may form part of a set of opposing electrodes in an electrochromic device structure. An optical component such as camera 200 (e.g., a digital image sensor and lens) may overlap device 16. Device 16 may be mounted above and/or below a lens for camera 200 and/or may be formed as part of a lens. Device 16 is preferably interposed between camera 200 and an object that is being imaged, so that device 16 can control the amount of light that reaches camera 200.

[0061] When it is desired to adjust the aperture for camera 200, an appropriate set of electrodes may be activated. If, for example, the widest possible aperture is desired in an arrangement of the type shown in FIG. 13, the first, second, and third electrodes may all be used to place corresponding overlapping portions of device 16 into a transparent state. If a slightly smaller aperture is desired, central electrode 28-1 and middle electrode 28-2 may be placed in a state that renders underlying portions of device 16 transparent, while outer electrode 28-3 is supplied with a voltage that renders the portions of device 16 under electrode 28-3 opaque. Different aperture sizes may be achieved by lightening and darkening portions of device 16 in this way during operation of camera 200.

[0062] In accordance with an embodiment, a system is provided that includes structures that form an interior region that is separated from an exterior region, and an electrochromatic device that forms a window in the structures, the electrochromatic device includes first and second layers, an electrolyte sandwiched between the first and second layers, and a first electrode adjacent to the first layer and a second electrode adjacent to the second layer, at least one of the first and second electrodes has a substrate, a seed layer on the substrate, a metal layer on the seed layer, and a protective layer on the metal layer.

[0063] In accordance with another embodiment, the protective layer includes a material selected from the group consisting of Ti, ZnAlO, and SiO₂.

[0064] In accordance with another embodiment, the protective layer includes titanium oxide.

[0065] In accordance with another embodiment, the protective layer includes a dielectric.

[0066] In accordance with another embodiment, the seed layer includes a crystalline layer.

[0067] In accordance with another embodiment, the seed layer includes a crystalline oxide layer.

[0068] In accordance with another embodiment, the seed layer includes a crystalline layer of ZnO.

[0069] In accordance with another embodiment, the metal layer includes silver.

[0070] In accordance with another embodiment, the first layer includes a material selected from the group consisting of NiO, CrO, and CoO.

[0071] In accordance with another embodiment, the second layer includes a material selected from the group consisting of WO₃, TiO, and MoO.

[0072] In accordance with another embodiment, the structures include structures selected from the group consisting of building structures, vehicle structures, and container structures.

[0073] In accordance with an embodiment, an electrochromic device is provided that includes an electrolyte sandwiched between first and second layers, and a first electrode adjacent to the first layer and a second electrode adjacent to the second layer, at least one of the first and second electrodes includes multiple layers each layer including a crystalline seed layer, a crystalline metal layer on the crystalline seed layer, and a protective layer on the crystalline metal layer.

[0074] In accordance with another embodiment, the crystalline metal layers include silver.

[0075] In accordance with another embodiment, the protective layers include an oxide.

[0076] In accordance with another embodiment, the crystalline seed layers include ZnO.

[0077] In accordance with another embodiment, the protective layers include titanium oxide.

[0078] In accordance with another embodiment, the titanium oxide layer has a thickness of less than 5 nm.

[0079] In accordance with an embodiment, apparatus is provided that includes an electrochromic device characterized by a light transmission level that changes in response to control signals, and a thin-film heater on the electrochromic device that heats the electrochromic device to enhance switching speed.

[0080] In accordance with another embodiment, the apparatus includes a light source that emits light that passes through the electrochromic device, a light sensor that measures the light that has passed through the electrochromic device, and control circuitry that uses the measured light to determine the light transmission level and that adjusts the thin-film heater

based at least partly on the light transmission level.

[0081] In accordance with another embodiment, the electrochromic device has a pair of electrodes each of which includes at least one crystalline oxide seed layer, at least one crystalline silver layer on the crystalline oxide seed layer, and at least one protective layer on the crystalline silver layer.

[0082] In accordance with another embodiment, the electrodes block at least 30% of infrared light from 700 nm to 2000 nm.

[0083] In accordance with another embodiment, the protective layer includes titanium oxide.

[0084] In accordance with an embodiment, apparatus is provided that includes an electrode that transmits visible light and that has a transparent substrate and a plurality of layers in a stack on the transparent substrate, each of the plurality of layers includes a crystalline oxide seed layer, a crystalline metal layer, and a protective layer.

[0085] In accordance with another embodiment, the apparatus includes display layers including a layer of liquid crystal material, the electrode includes a common voltage electrode layer in the display layers.

[0086] In accordance with another embodiment, the apparatus includes display layers that form an array of organic light-emitting diodes, the electrode includes a cathode layer in the display layers.

[0087] In accordance with another embodiment, the apparatus includes layers that form a touch sensor, the electrode includes a touch sensor electrode for the touch sensor.

[0088] In accordance with another embodiment, the protective layer includes an oxide layer having a thickness of less than 5 nm.

[0089] In accordance with another embodiment, the protective layer includes titanium oxide.

[0090] In accordance with another embodiment, the apparatus includes a camera, and an adjustable aperture electrochromic device that overlaps the camera, the electrode includes one of a plurality of electrodes in the adjustable aperture electrochromic device that are independently adjusted to adjust the adjustable aperture electrochromic device.

[0091] The foregoing is merely illustrative and various modifications can be made by those skilled in the art without departing from the scope and spirit of the described embodiments. The foregoing embodiments may be implemented individually or in any combination.

Claims

What is Claimed is:

1. A system, comprising:
structures that form an interior region that is separated from an exterior region;
an electrochromatic device that forms a window in the structures,
wherein the electrochromatic device includes:
first and second layers;
an electrolyte sandwiched between the first and second layers;
and
a first electrode adjacent to the first layer and a second electrode adjacent to the second layer, wherein at least one of the first and second electrodes has a substrate, a seed layer on the substrate, a metal layer on the seed layer, and a protective layer on the metal layer; and
control circuitry configured to control light transmission into the interior region through the window by adjusting voltage applied to one or more of the first and second electrodes of the electrochromatic device.
2. The system defined in claim 1 wherein the protective layer comprises a material selected from the group consisting of Ti, ZnAlO, and SiO₂.
3. The system defined in claim 1 wherein the protective layer comprises titanium oxide.
4. The system defined in claim 1 wherein the protective layer comprises a dielectric.
5. The system defined in claim 1 wherein the seed layer comprises a crystalline layer.
6. The system defined in claim 1 wherein the seed layer comprises a

crystalline oxide layer.

7. The system defined in claim 1 wherein the seed layer comprises a crystalline layer of ZnO.
8. The system defined in claim 1 wherein the metal layer comprises silver.
9. The system defined in claim 1 wherein the first layer comprises a material selected from the group consisting of: NiO, CrO, and CoO.
10. The system defined in claim 1 wherein the second layer comprises a material selected from the group consisting of: WO₃, TiO, and MoO.
11. The system defined in claim 1 wherein the structures comprise structures selected from the group consisting of: building structures, vehicle structures, and container structures.
12. An electrochromic device, comprising:
 - an electrolyte sandwiched between first and second layers; and
 - a first electrode adjacent to the first layer and a second electrode adjacent to the second layer, wherein at least one of the first and second electrodes includes multiple layers each layer including a crystalline seed layer, a crystalline metal layer on the crystalline seed layer, and a protective layer on the crystalline metal layer.
13. The electrochromic display defined in claim 12 wherein the crystalline metal layers comprise silver.
14. The electrochromic display defined in claim 13 wherein the protective layers comprise an oxide.
15. The electrochromic display defined in claim 14 wherein the crystalline

seed layers comprise ZnO.

16. The electrochromic display defined in claim 15 wherein the protective layers comprise titanium oxide.

17. The electrochromic display defined in claim 16 wherein the titanium oxide layer has a thickness of less than 5 nm.

18. Apparatus, comprising:
an electrochromic device characterized by a light transmission level that that changes in response to control signals; and
a thin-film heater on the electrochromic device that heats the electrochromic device to enhance switching speed.

19. The apparatus defined in claim 18 further comprising:
a light source that emits light that passes through the electrochromic device;
a light sensor that measures the light that has passed through the electrochromic device; and
control circuitry that uses the measured light to determine the light transmission level and that adjusts the thin-film heater based at least partly on the light transmission level.

20. The apparatus defined in claim 19 wherein the electrochromic device has a pair of electrodes each of which includes at least one crystalline oxide seed layer, at least one crystalline silver layer on the crystalline oxide seed layer, and at least one protective layer on the crystalline silver layer.

21. The apparatus defined in claim 20 wherein the electrodes block at least 30% of infrared light from 700 nm to 2000 nm.

22. The apparatus defined in claim 20 wherein the protective layer

comprises titanium oxide.

23. The apparatus defined in claim 18 wherein the electrochromic device has an area and wherein the thin-film heater covers less than 50% of the area.

24. Apparatus, comprising:
an electrode that transmits visible light and that has a transparent substrate and a plurality of layers in a stack on the transparent substrate, wherein each of the plurality of layers includes a crystalline oxide seed layer, a crystalline metal layer, and a protective layer.

25. The apparatus defined in claim 24 further comprising:
display layers including a layer of liquid crystal material, wherein the electrode comprises a common voltage electrode layer in the display layers.

26. The apparatus defined in claim 24 further comprising:
display layers that form an array of organic light-emitting diodes, wherein the electrode comprises a cathode layer in the display layers.

27. The apparatus defined in claim 26 further comprising:
layers that form a touch sensor, wherein the electrode comprises a touch sensor electrode for the touch sensor.

28. The apparatus defined in claim 24 wherein the protective layer comprises an oxide layer having a thickness of less than 5 nm.

29. The apparatus defined in claim 28 wherein the protective layer comprises titanium oxide.

30. The apparatus defined in claim 24 further comprising:
a camera; and
an adjustable aperture electrochromic device that overlaps the camera,

wherein the electrode comprises one of a plurality of electrodes in the adjustable aperture electrochromic device that are independently adjusted to adjust the adjustable aperture electrochromic device.

1/11

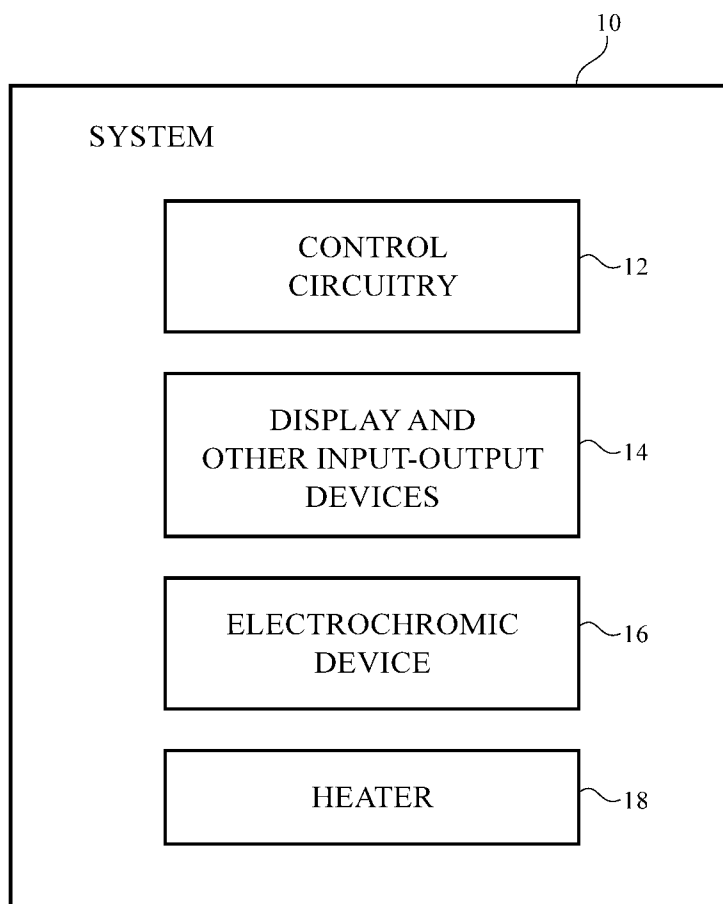

FIG. 1

2/11

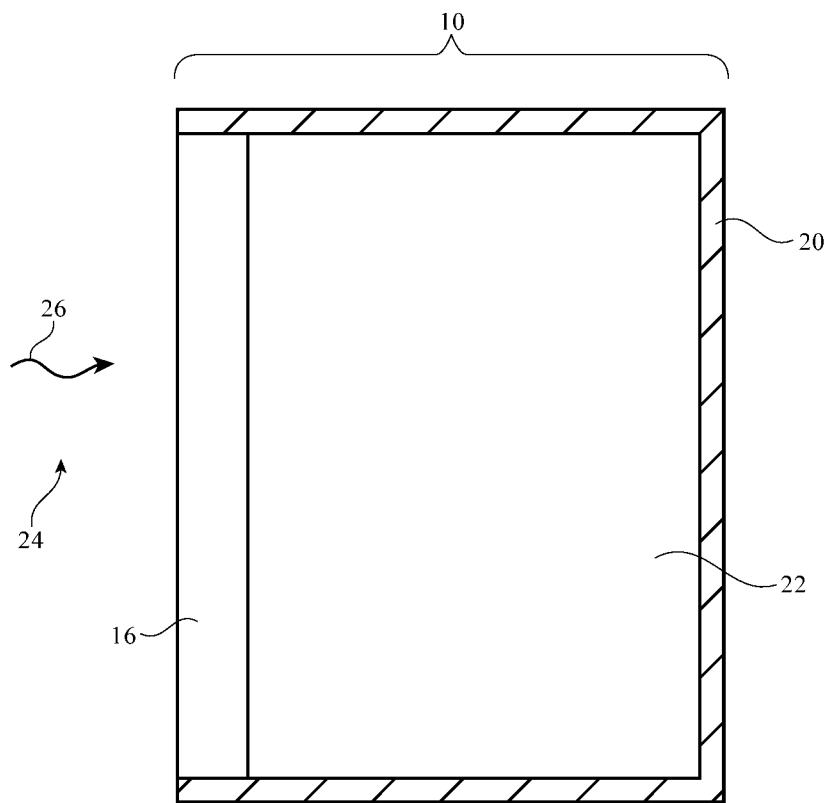

FIG. 2

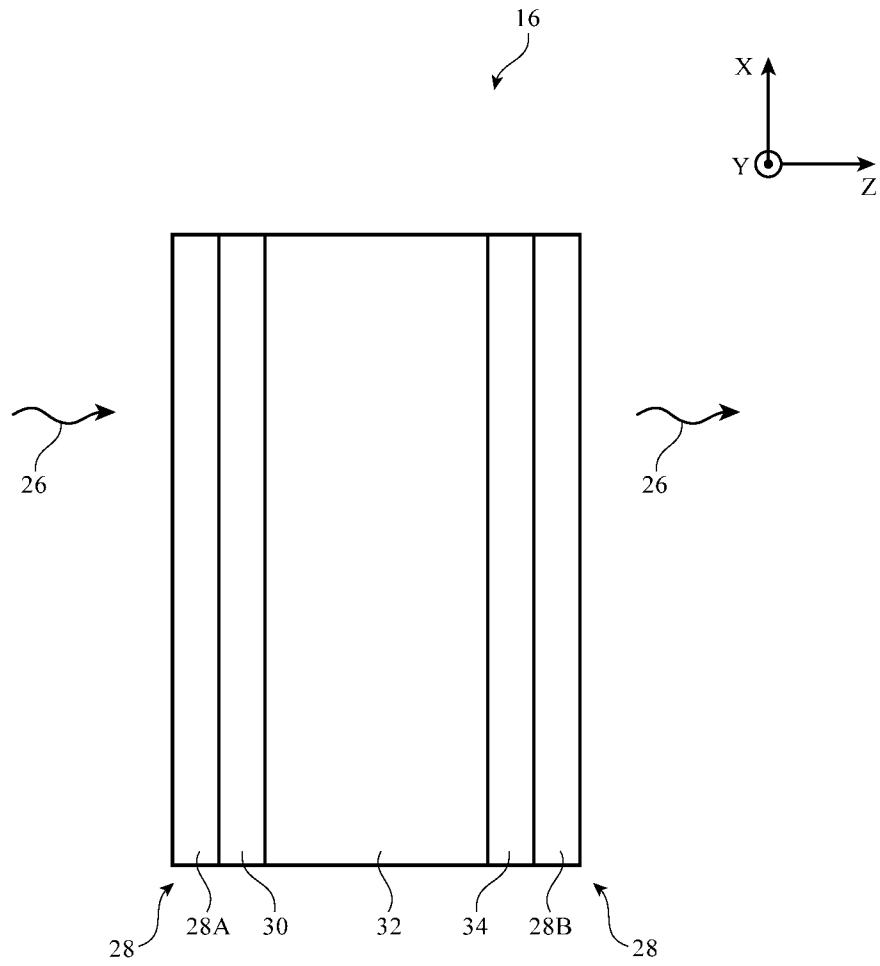

FIG. 3

4/11

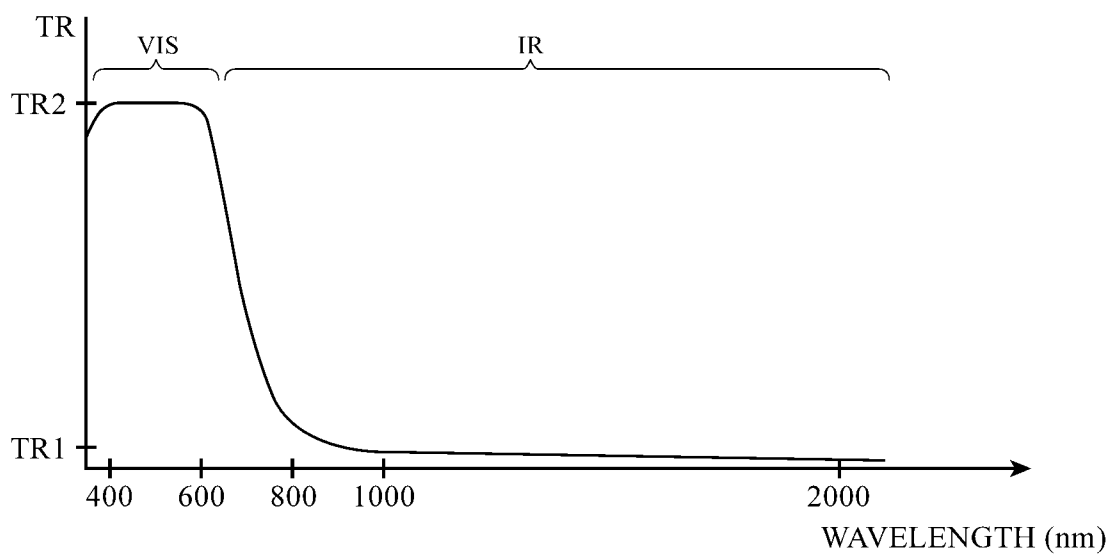

FIG. 4

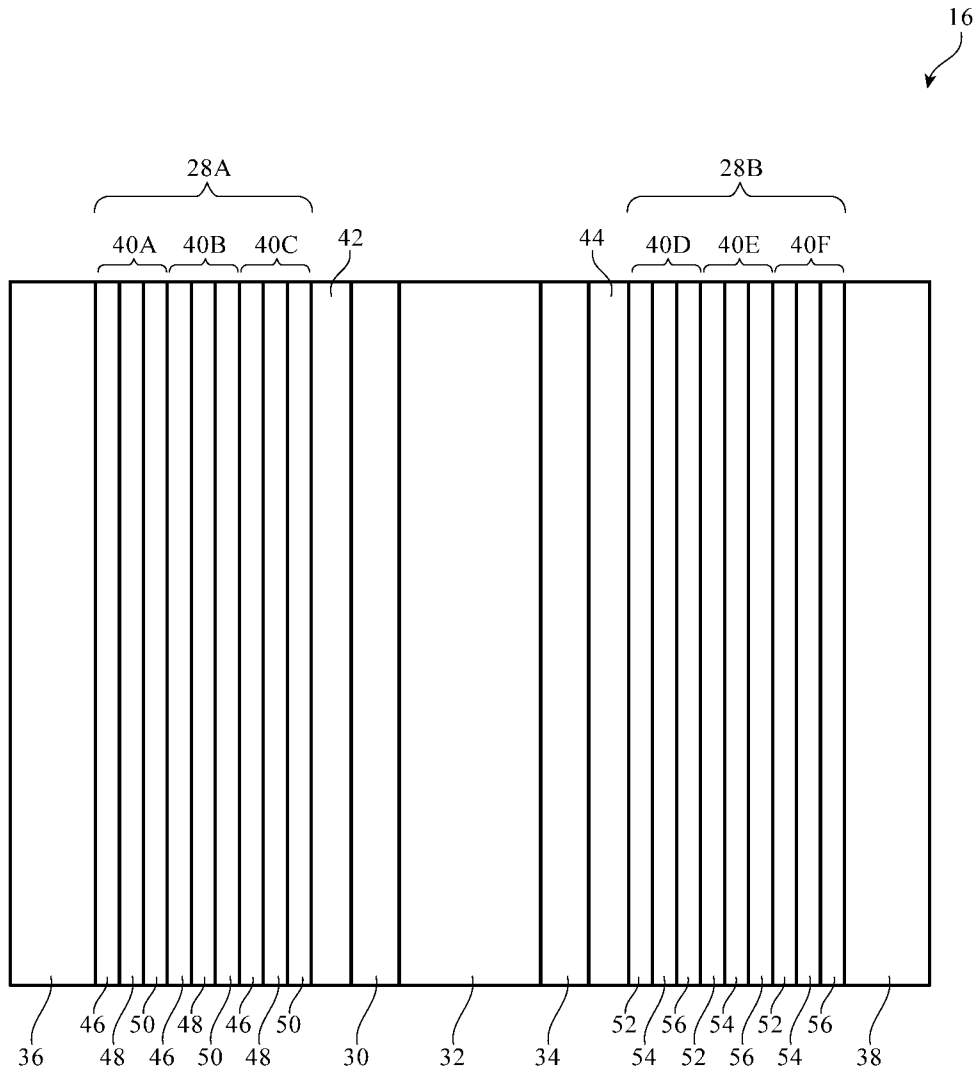

FIG. 5

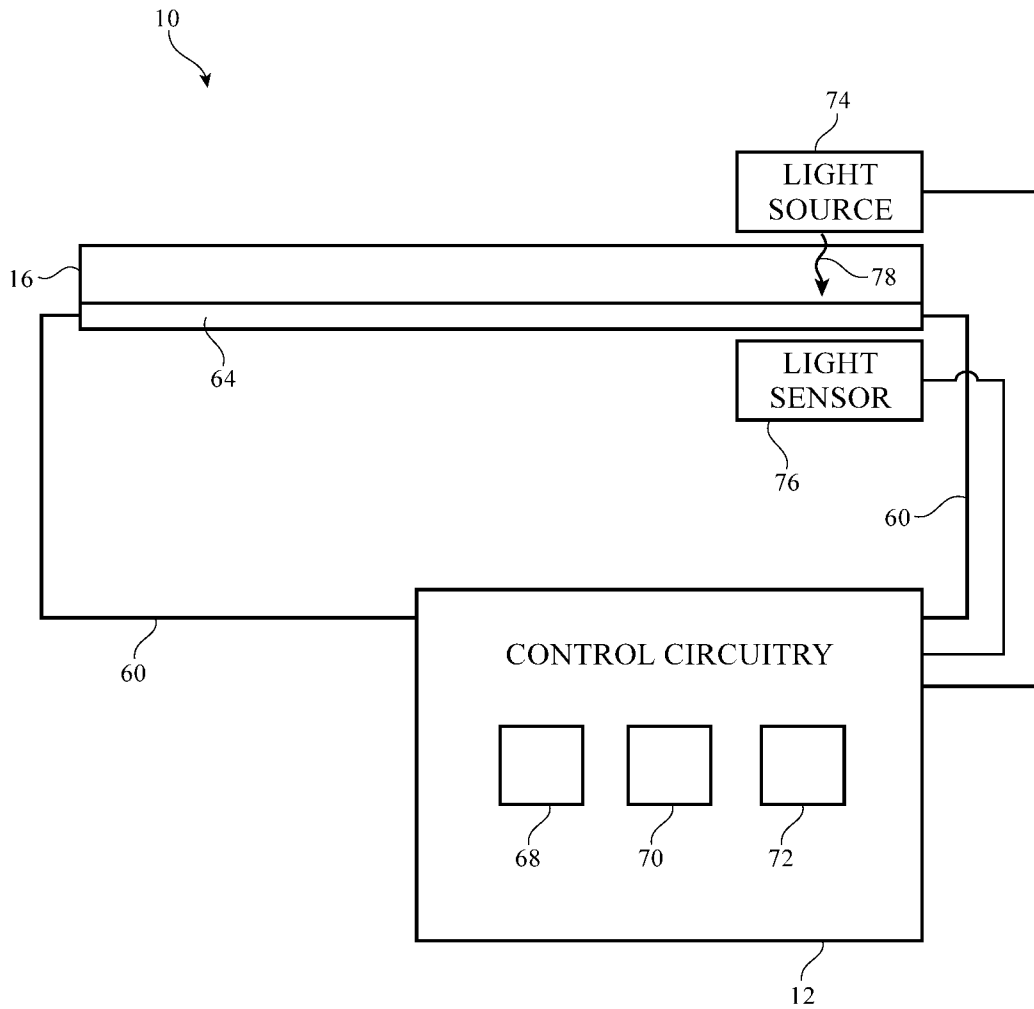

FIG. 6

7/11

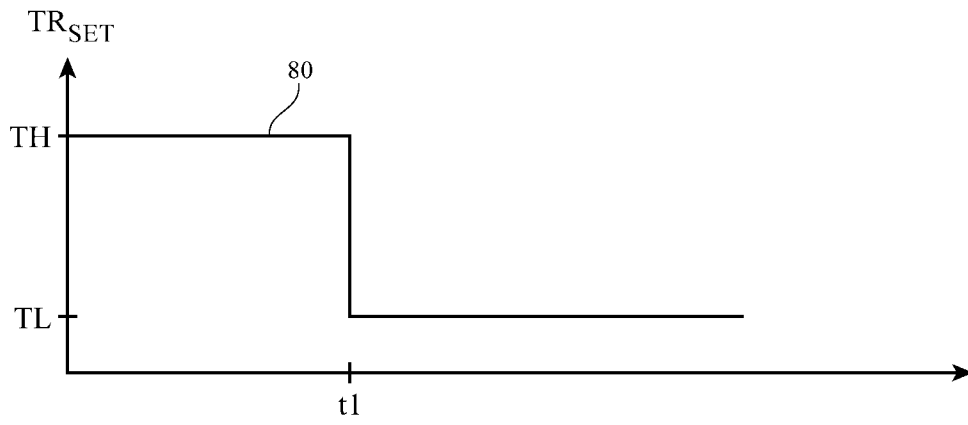

FIG. 7

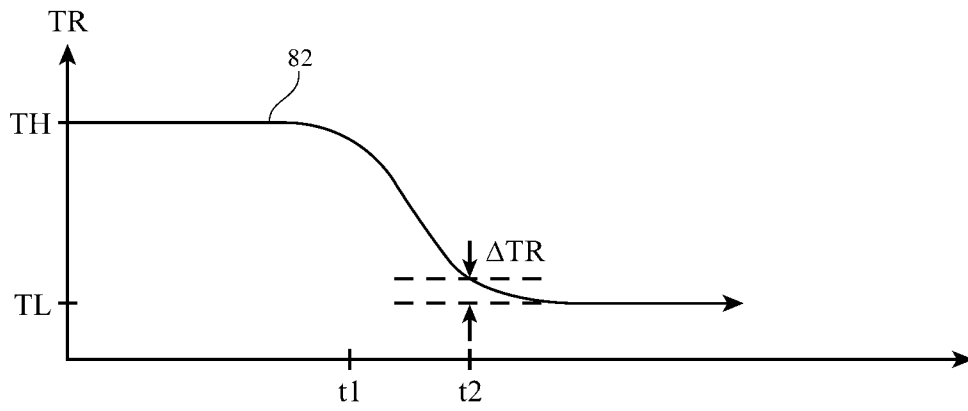

FIG. 8

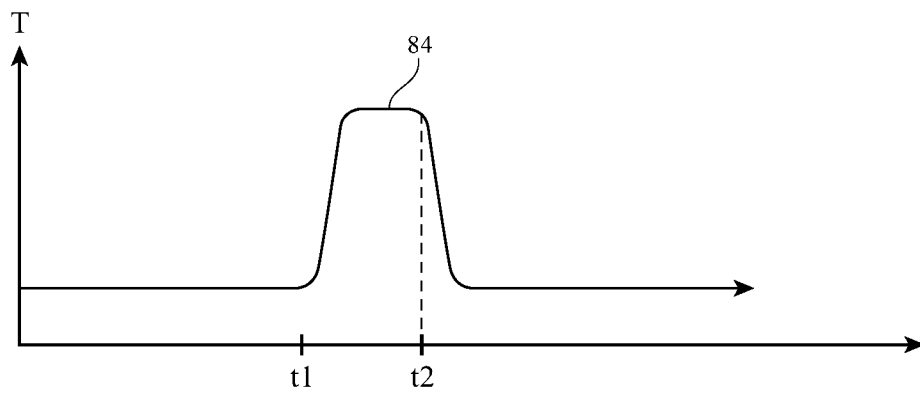

FIG. 9

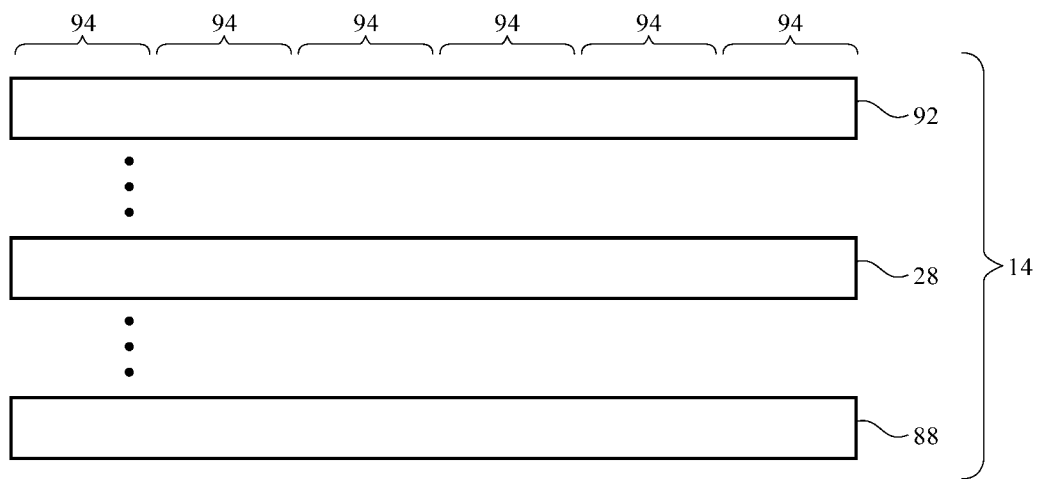

FIG. 10

9/11

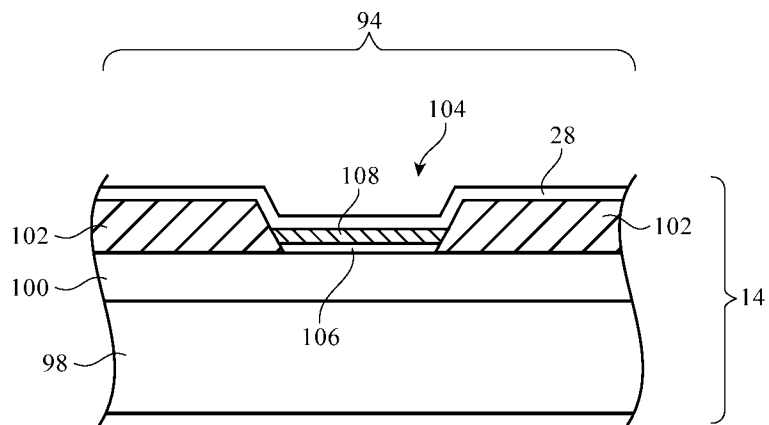

FIG. 11

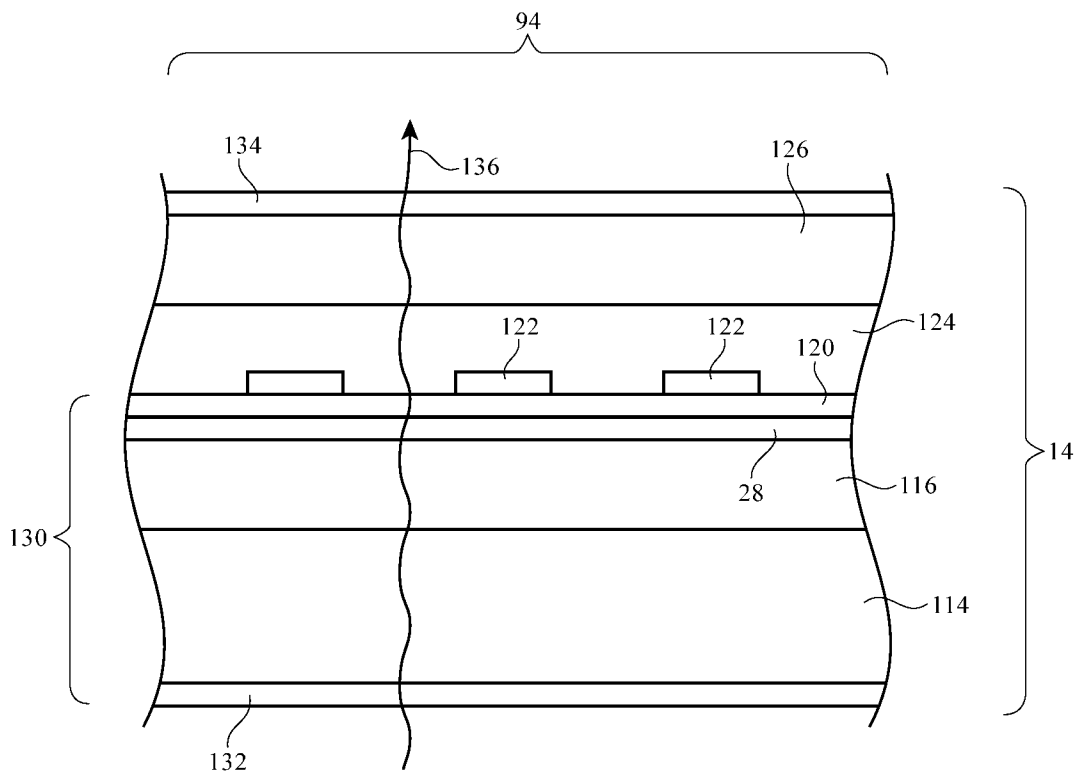

FIG. 12

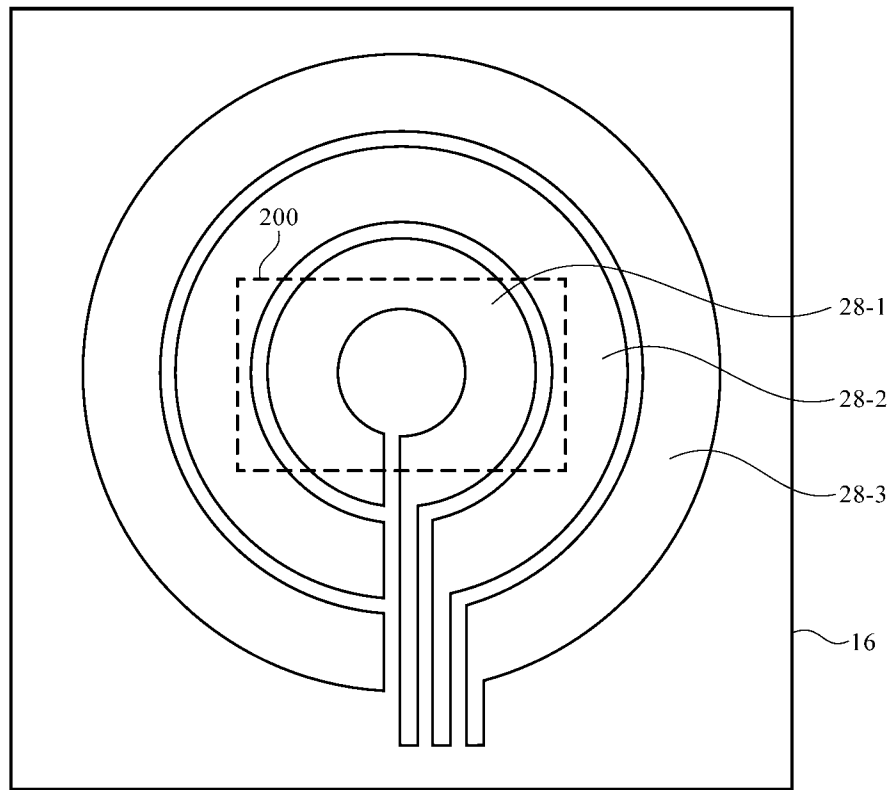

FIG. 13