



US 20110253294A1

(19) **United States**  
(12) **Patent Application Publication**  
**Weder**

(10) **Pub. No.: US 2011/0253294 A1**  
(43) **Pub. Date: Oct. 20, 2011**

(54) **METHOD FOR FORMING A DECORATIVE COVER FOR A FLOWER POT WITH A SHEET OF MATERIAL HAVING PRINTED AND EMBOSSED PATTERNS THEREON**

filed on Jun. 26, 2002, now Pat. No. 6,564,507, which is a continuation of application No. 10/051,828, filed on Jan. 17, 2002, now abandoned, which is a continuation of application No. 09/606,812, filed on Jun. 28, 2000, now Pat. No. 6,347,480, which is a continuation-in-part of application No. 08/888,813, filed on Jul. 7, 1997, now abandoned, which is a division of application No. 08/480,657, filed on Jun. 7, 1995, now Pat. No. 5,752,360.

(76) Inventor: **Donald E. Weder**, Highland, IL (US)

(21) Appl. No.: **13/172,956**

(22) Filed: **Jun. 30, 2011**

**Publication Classification**

(51) **Int. Cl.**  
**B65H 81/00** (2006.01)  
(52) **U.S. Cl.** ..... **156/185**

**Related U.S. Application Data**

(60) Continuation of application No. 12/723,132, filed on Mar. 12, 2010, now abandoned, which is a continuation of application No. 11/803,962, filed on May 16, 2007, now abandoned, which is a continuation of application No. 10/721,368, filed on Nov. 25, 2003, now abandoned, which is a division of application No. 10/385,084, filed on Mar. 10, 2003, now abandoned, which is a continuation of application No. 10/183,786,

(57) **ABSTRACT**

A decorative covering for a flower pot wherein a sheet of material having embossed and printed patterns thereon is formed about at least a portion of the flower pot.

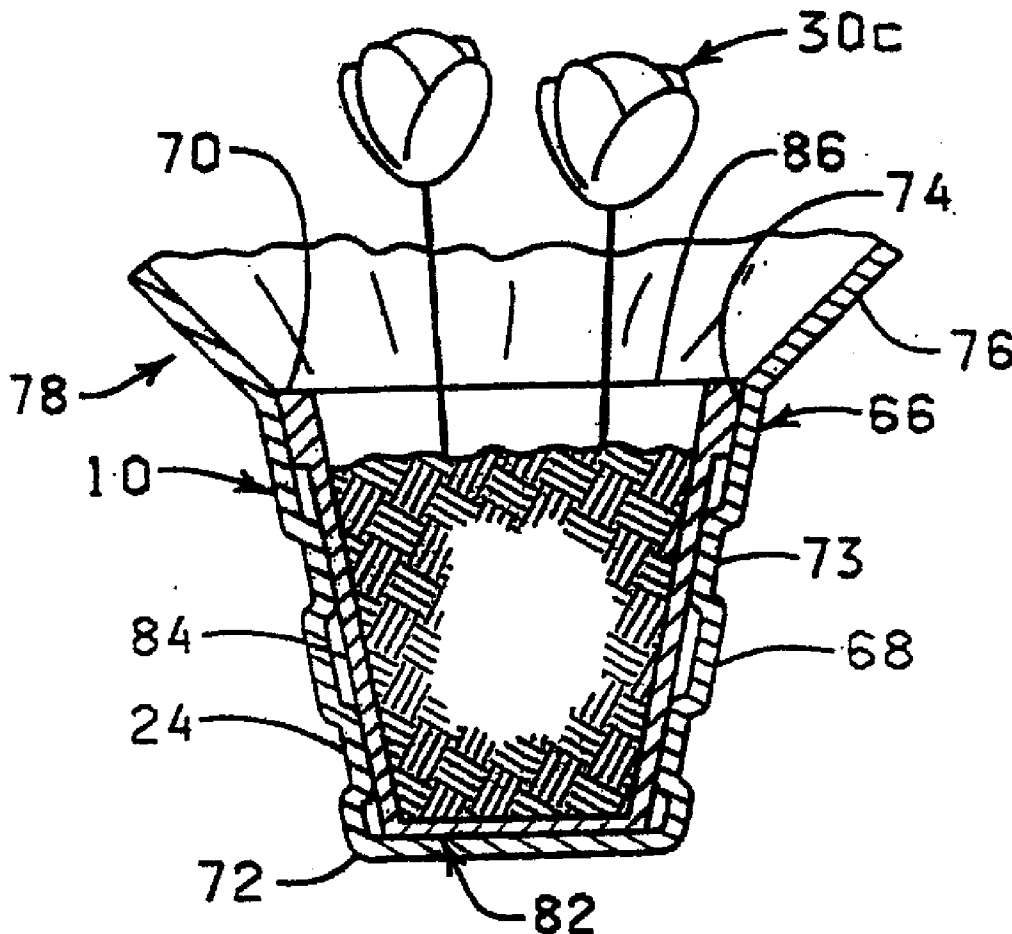

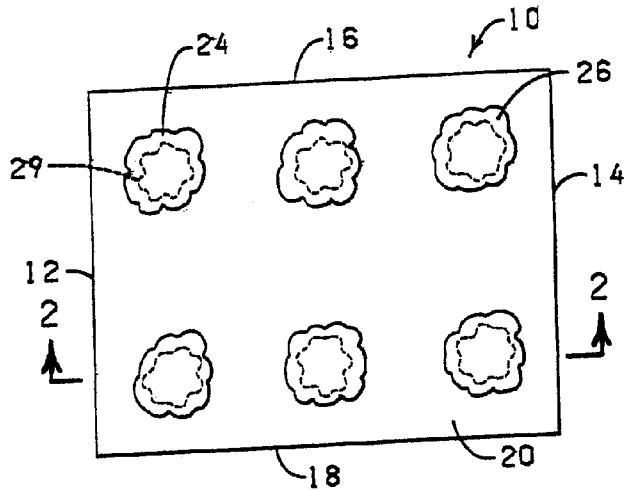

FIG. 1

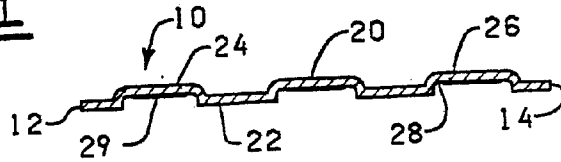

FIG. 2

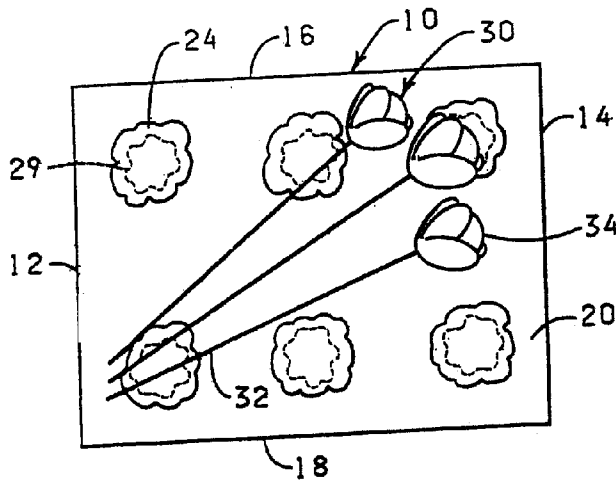

FIG. 3

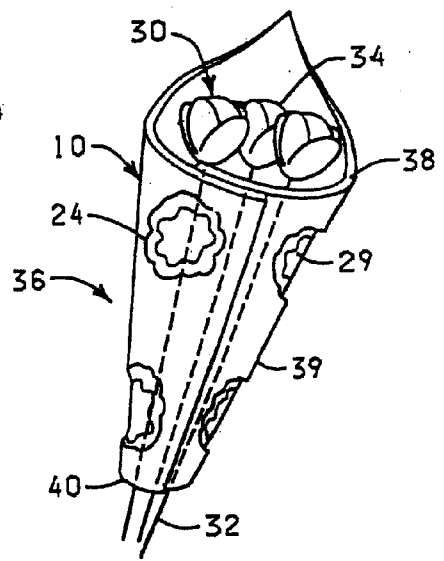
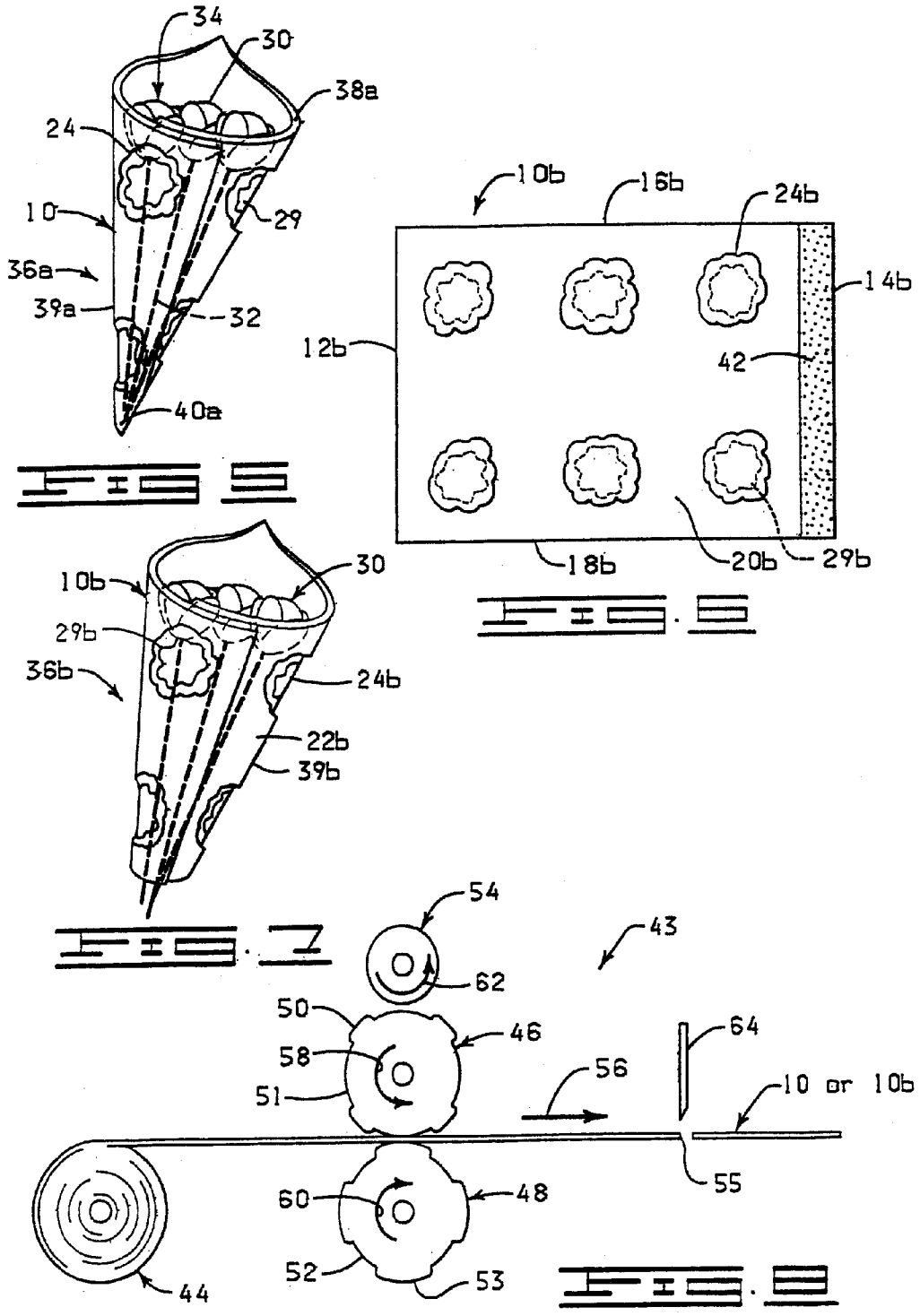
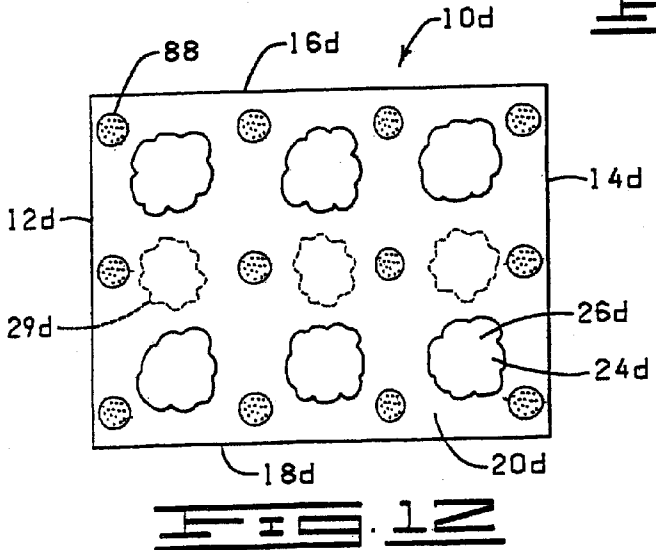
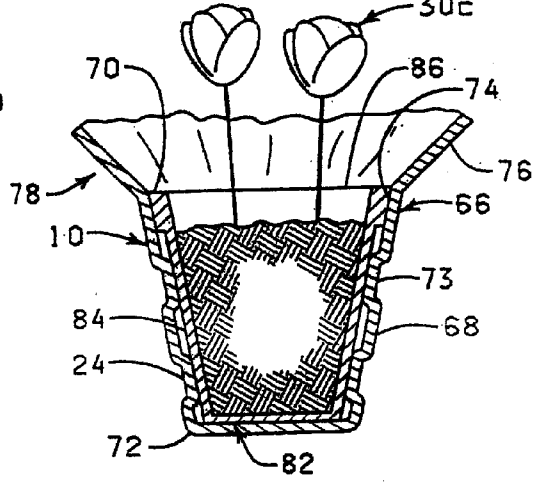
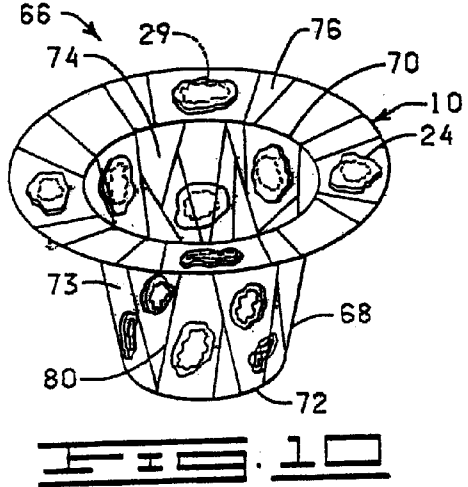
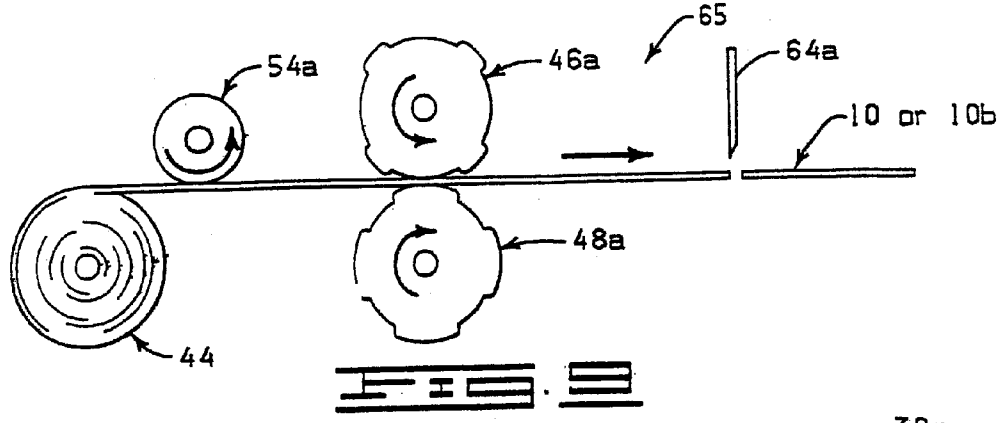

FIG. 4





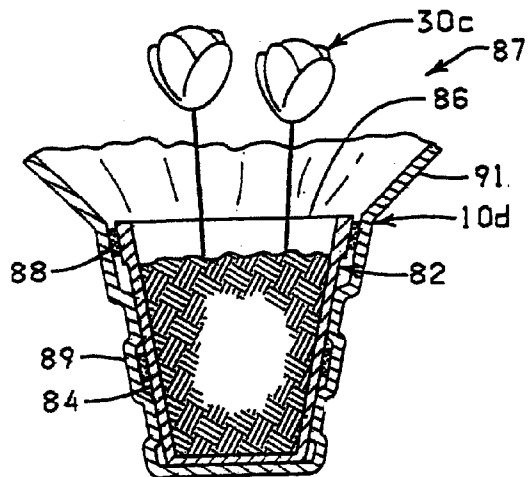

FIG. 13

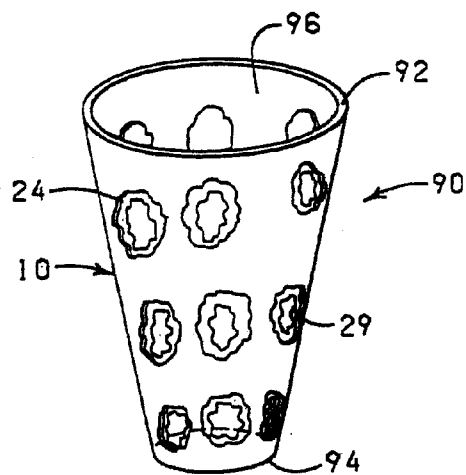

FIG. 14

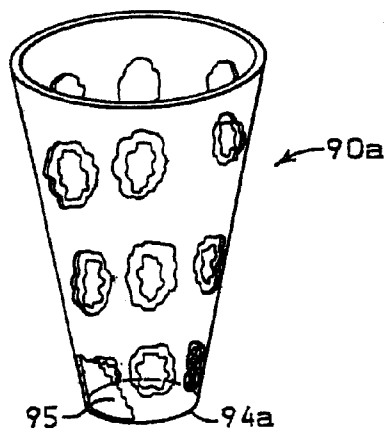

FIG. 14A

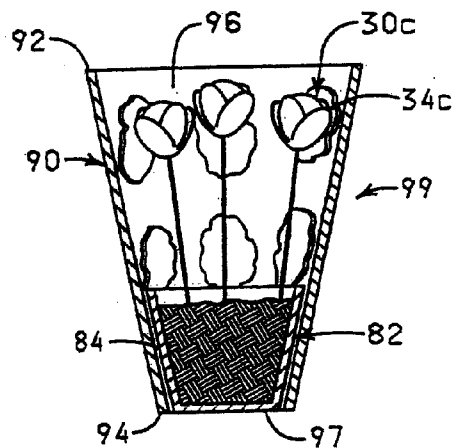

FIG. 15

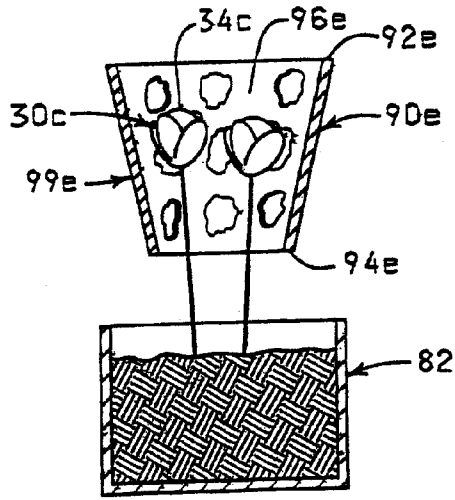

FIG. 16

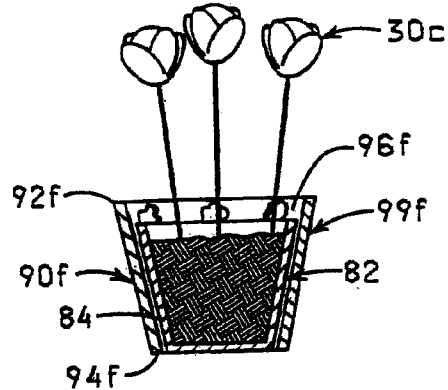

FIG. 17

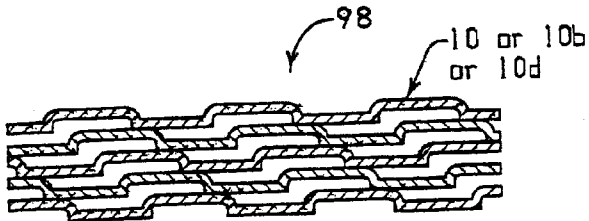

FIG. 18

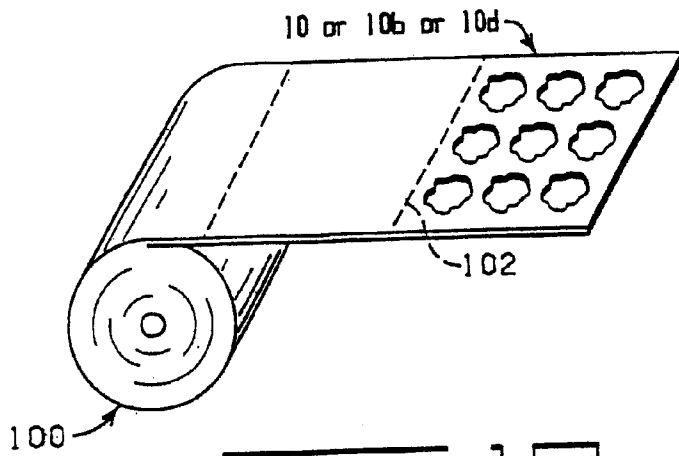

FIG. 19

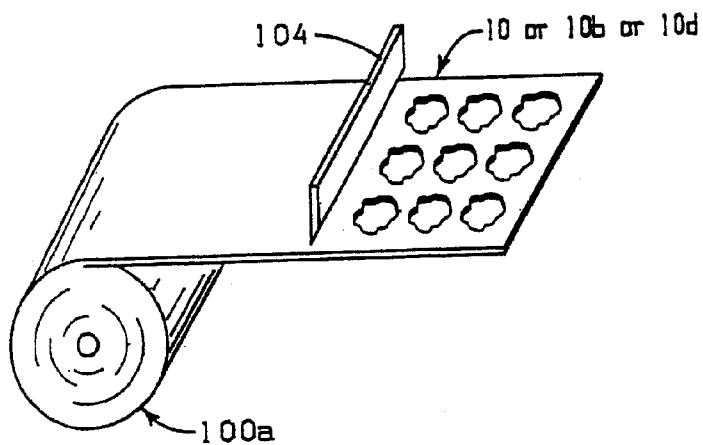

FIG. 20

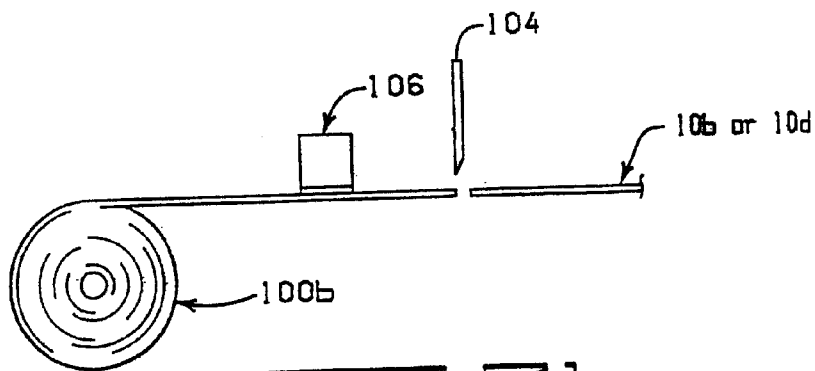

FIG. 21

**METHOD FOR FORMING A DECORATIVE COVER FOR A FLOWER POT WITH A SHEET OF MATERIAL HAVING PRINTED AND EMBOSSED PATTERNS THEREON**

**CROSS REFERENCE TO RELATED APPLICATIONS**

[0001] The present application is a continuation of U.S. Ser. No. 12/723,132, filed Mar. 12, 2010, now abandoned; which is a continuation of U.S. Ser. No. 11/803,962, filed May 16, 2007, now abandoned; which is a continuation of U.S. Ser. No. 10/721,368, filed Nov. 25, 2003, now abandoned; which is a divisional of U.S. Ser. No. 10/385,084, filed Mar. 10, 2003, now abandoned; which is a continuation of U.S. Ser. No. 10/183,786, filed Jun. 26, 2002, now U.S. Pat. No. 6,564,507, issued May 20, 2003; which is a continuation of U.S. Ser. No. 10/051,828, filed Jan. 17, 2002, now abandoned; which is a continuation of U.S. Ser. No. 09/606,812, filed Jun. 28, 2000, now U.S. Pat. No. 6,347,480, issued Feb. 19, 2002; which is a continuation-in-part of U.S. Ser. No. 08/888,813, filed Jul. 7, 1997, now abandoned; which is a divisional of U.S. Ser. No. 08/480,657, filed Jun. 7, 1995, now U.S. Pat. No. 5,752,360, issued May 19, 1998, the contents of which are hereby expressly incorporated herein by reference in their entirety.

**FIELD OF THE INVENTION**

[0002] The presently disclosed and claimed inventive concept(s) relates generally to methods for wrapping floral groupings or flower pots wherein the floral grouping or flower pot is wrapped with a sheet of material having a pattern embossed thereon and a pattern printed thereon.

**BRIEF DESCRIPTION OF THE DRAWINGS**

[0003] FIG. 1 is a plan view of a sheet of material constructed in accordance with the presently disclosed and claimed inventive concept(s).  
[0004] FIG. 2 is a sectional view of the sheet of material shown in FIG. 1 taken substantially along the lines 2-2 of FIG. 1.  
[0005] FIG. 3 is a plan view of the sheet of material of FIGS. 1 and 2 showing a floral grouping disposed thereon prior to the sheet of material being wrapped about the floral grouping.  
[0006] FIG. 4 is a perspective view showing the sheet of material of FIGS. 1-3 wrapped about the floral grouping of FIG. 3.  
[0007] FIG. 5 is a perspective view similar to FIG. 4, but showing the sheet of material of FIGS. 1-3 wrapped about the floral grouping in a different manner as compared to that shown in FIG. 4.  
[0008] FIG. 6 is a plan view of a sheet of material which is similar to the sheet of material shown in FIG. 1, but having a bonding material disposed thereon.  
[0009] FIG. 7 is a perspective view showing the sheet of material of FIG. 6 wrapped about a floral grouping.  
[0010] FIG. 8 is a schematic view illustrating the embossing of a pattern on the sheets of material described herein and showing the printing of a pattern on the sheets of material wherein the printed pattern is in register with the embossed pattern.  
[0011] FIG. 9 is a schematic view, similar to FIG. 8, but showing a modified system for embossing a pattern on the

sheets of material described herein and printing a pattern on the sheets of material wherein the printed pattern is out of register with the embossed pattern.

[0012] FIG. 10 is a perspective view of a pot cover constructed using the sheet of material shown in FIG. 1.  
[0013] FIG. 11 is a cross-sectional view showing the pot cover of FIG. 10 disposed about a flower pot having a floral grouping disposed therein.  
[0014] FIG. 12 is a top plan view of another sheet of material which is similar to the sheet of material shown in FIG. 1, but having a plurality of spots of bonding material disposed thereon.  
[0015] FIG. 13 is a cross-sectional view showing the sheet of material of FIG. 12 wrapped about a flower pot having a floral grouping disposed therein wherein the spots of bonding material secure the sheet of material to the flower pot.  
[0016] FIG. 14 is a perspective view showing a plant sleeve having an embossed pattern thereon.  
[0017] FIG. 14a is a partially cut away perspective view showing a plant sleeve having an embossed pattern thereon and a closed lower end.  
[0018] FIG. 15 is a cross-sectional view showing the plant sleeve of FIG. 14 disposed about a flower pot having a floral grouping disposed therein.  
[0019] FIG. 16 is a cross-sectional view of a flower pot having a floral grouping therein with a modified plant sleeve disposed about a bloom end of the floral grouping.  
[0020] FIG. 17 is a cross-sectional view of a flower pot having a floral grouping disposed therein and having a modified plant sleeve disposed about the flower pot.  
[0021] FIG. 18 is a cross-sectional view of a pad of material containing a plurality of sheets of material constructed in accordance with the presently disclosed and claimed inventive concept(s).  
[0022] FIG. 19 is a perspective view of a roll of material formed of sheets of material constructed in accordance with the presently disclosed and claimed inventive concept(s) wherein the sheets of material are separated from the roll of material by tearing along the lines of perforations.  
[0023] FIG. 20 is a perspective view of a roll of material formed of sheets of material constructed in accordance with the presently disclosed and claimed inventive concept(s) wherein the sheets of material are separated from the roll of material by a knife.  
[0024] FIG. 21 is a schematic view showing a roll of material formed of sheets of material wherein a bonding material is applied to the roll of material and the sheets of material are cut from the roll of material by way of a knife.

**DETAILED DESCRIPTION OF THE PRESENTLY DISCLOSED AND CLAIMED INVENTIVE CONCEPT(S)**

**Embodiment of FIGS. 1-5**

[0025] Shown in FIGS. 1-3 is a sheet of material 10 constructed in accordance with the presently disclosed and claimed inventive concept(s). The sheet of material 10 may be constructed of any material which is suitable for use with the presently disclosed and claimed inventive concept(s). That is, the sheet of material 10 may be constructed of any flexible material capable of being wrapped about a floral grouping or flower pot. Examples of materials from which the sheet of material 10 may be constructed include paper, polymeric



film, metallized film, foil, and laminations and combinations thereof. Preferably, the sheet of material 10 is constructed of paper.

[0026] The sheet of material 10 shown in FIG. 1 is rectangular shaped, although the sheet of material 10 may be any other shape, such as square, elliptical or round, or may be die cut into any shape, such as a rose shape. The sheet of material 10 has a first side 12, second side 14, a first end 16, a second end 18, an upper surface 20 and a lower surface 22 (FIG. 2).

[0027] An embossed pattern 24 is formed on at least a portion of one of the upper surface 20 and the lower surface 22 of the sheet of material 10. The embossed pattern 24 may be any one of a number of patterns such as depictions of flowers or logos or meaningless designs, for example. The embossed pattern 24 forms a plurality of spaced apart raised portions 26 in the upper surface 20 of the sheet of material 10 (only one of the raised portions 26 is designated with the reference numeral in FIGS. 1 and 2). The embossed pattern 24 also forms a plurality of corresponding depressed portions 28 (only one of the depressed portions 28 being designated with the reference numeral in FIG. 2) in the lower surface 22 of the sheet of material 10. Each of the depressed portions 28 corresponds to one of the raised portions 26. The embossed pattern 24 may cause the raised portions 26 and the corresponding depressed portions 28 to be uniformly raised and depressed, or each of the raised portions 26 and corresponding depressed portions 28 may include portions raised and depressed to different heights as may be desired in a particular application.

[0028] The embossed pattern 24 of the sheet of material 10 provides more rigidity as compared to an unembossed sheet of material, such that a lighter material can serve the same purpose as compared to heavier sheets of material. Further, the embossed sheets of material 10 described herein give the appearance in a roll or a stack of more material or volume of material being contained in such roll or stack. The embossing of the sheets of material 10 to provide the embossed pattern 24 also adds strength to the material. In addition, the embossing of the sheets of material 10 provides more absorbency per square inch as compared to unembossed sheets of material, and thus the embossed sheets of material 10 described herein absorb more moisture or absorb the moisture quicker. The embossed sheets of material 10 also provide an insulating quality due to the air space formed by the embossed pattern 24.

[0029] In addition to the embossed pattern 24, the sheet of material 10 may further include a decorative pattern 29 printed on at least a portion of the upper surface 20 of the sheet of material 10, the lower surface 22 of the sheet of material 10 or both the upper and lower surfaces 20 and 22 of the sheet of material if desired. In FIGS. 1 and 2, the decorative printed pattern 29 is depicted as being disposed on the lower surface 22 of the sheet of material 10 and in register with the depressed portions 28 of the embossed pattern 24. The decorative printed pattern 29 may be a solid color or a printed pattern comprising one or more colors. The decorative printed pattern 29 may be in register with the embossed pattern 26 as illustrated in FIGS. 1 and 2, or the decorative printed pattern 29 may be out of register with the embossed pattern 24, or a portion of the decorative printed pattern 29 may be in register with the embossed pattern 24 while a portion of the decorative printed pattern 29 may be out of register with the embossed pattern 24. The upper surface 20 or the lower surface 22 or

both the upper and lower surfaces 22 and 24 of the sheet of material 10 may also include a metallic finish.

[0030] In operation, the sheet of material 10 is embossed to provide the embossed pattern 24 thereon and printed to provide the printed pattern 29 thereon. A floral grouping 30 (FIGS. 3 and 4) having a stem end 32 and a bloom end 34 is placed on the upper surface 20 of the sheet of material 10 (as shown in FIG. 3). It should be noted that the floral grouping 30 may be placed on the lower surface 22 of the sheet of material 10 if desired in a particular application. The sheet of material 10 then is wrapped about the floral grouping 30 to provide a decorative wrapper 36 (shown in FIG. 4) which encompasses a substantial portion of the floral grouping 30.

[0031] The decorative wrapper 36 has an upper end 38, a lower end 40 and an outer peripheral surface 39 (FIG. 4). The upper end 38 is opened and the lower end 40 is opened. At least a portion of the embossed pattern 24 and at least a portion of the printed pattern 29 provided on the sheet of material 10 from which the decorative wrapper 36 is constructed are visible on the outer peripheral surface 39 of the decorative wrapper 36. The decorative wrapper 36 encompasses a substantial portion of the floral grouping 30 with the stem end 32 of the floral grouping 30 extending through the open lower end 40 of the decorative wrapper 36. The bloom end 34 of the floral grouping 30 is exposed via the open upper end 38 of the decorative wrapper 36.

[0032] In FIG. 5, the sheet of material 10 is wrapped about the floral grouping 30 in a slightly different manner as compared to that described before with respect to FIG. 4 to provide a modified decorative wrapper 36a. The decorative wrapper 36a has an upper end 38a, a lower end 40a and an outer peripheral surface 39a, and at least a portion of the embossed pattern 24 and at least a portion of the printed pattern 29 disposed on the sheet of material 10 from which the decorative wrapper 36a is constructed are visible on the outer peripheral surface 39a of the decorative wrapper 36a.

[0033] As shown in FIG. 5, the stem end 32 of the floral grouping 30 does not extend through the lower end 40a of the decorative wrapper 36a, and the bloom end 34 of the floral grouping 30 is disposed below the upper end 38a of the decorative wrapper 36a. The lower end 40a of the decorative wrapper 36a may be closed by simply crimping portions of the sheet of material 10 adjacent the lower end 40a together or by securing the lower end 40a in a closed position by tying a string or ribbon or other securing element or material about the lower end 40a of the decorative wrapper 36a. The upper end 38a of the decorative wrapper 36a may also be closed in a similar manner if desired in a particular application.

[0034] With either the decorative wrapper 36 or the decorative wrapper 36a, the sheet of material 10 is wrapped about the floral grouping 30 to a position wherein a portion of the sheet of material 10 overlaps other portions of the sheet of material 10 to provide the decorative wrapper 36 or 36a with a substantially conically shaped configuration. The decorative wrapper 36 or 36a may be secured in this wrapped position about the floral grouping 30 by taping the overlapping portion of the sheet of material 10 to the adjacent portions of the sheet of material 10, or by bonding the overlapping portion of the sheet of material 10 to the adjacent portions of the sheet of material 10, or by tying a ribbon or string or other binder around the decorative wrapper 36 or 36a to secure the sheet of material 10 in the conically shaped form of the decorative wrapper 36 or 36a if desired in a particular application.

[0035] “Floral grouping” as used herein means cut fresh flowers, artificial flowers, a single flower, other fresh and/or artificial plants or other floral materials and may include other secondary plants and/or ornamentation which add to the aesthetics of the overall floral grouping.

#### Embodiment of FIGS. 6 and 7

[0036] Shown in FIG. 6 is a modified sheet of material **10b** which is constructed similar to the sheet of material **10** shown in FIGS. 1 and 2 and described in detail before, except as described herein below. The sheet of material **10b** is provided with a first side **12b**, a second side **14b**, a first end **16b**, a second end **18b**, an upper surface **20b**, a lower surface **22b** (FIG. 7), an embossed pattern **24b** and a printed pattern **29b**. In FIGS. 6 and 7, the printed pattern **29b** is disposed on at least a portion of the lower surface **22b** of the sheet of material **10b**, and the printed and embossed patterns **29b** and **24b** are in register with one another. In addition, the sheet of material **10b** also includes a bonding material **42** disposed on a portion of the upper surface **20b** thereof near the second side **14b** which extends between the first and the second ends **16b** and **18b** of the sheet of material **10b**.

[0037] The bonding material **42** preferably is an adhesive or pressure sensitive adhesive material. The bonding material **42** may be a cohesive material; however, in that event, a corresponding strip or spot of cohesive material also must be applied to the lower surface **22b** of the sheet of material **10b** to connect with the cohesive bonding material **42** on the upper surface **20b** of the sheet of material **10b**. Alternatively, the bonding material **42** may be applied to at least a portion of the lower surface **22b** of the sheet of material **10b**.

[0038] The term “bonding material” as used herein means an adhesive, preferably a pressure sensitive adhesive, or a cohesive. Where the bonding material **42** is a cohesive, a similar cohesive material must be placed on the adjacent surface of the sheet of material **10b** for bondingly contacting and bondingly engaging with the cohesive material. The term “bonding material” also includes materials which are heat sealable and, in this instance, the adjacent portions of the sheet of material **10b** must be brought into contact and then heat must be applied to effect the seal. The term “bonding material” as used herein also means a heat sealing lacquer which may be applied to the sheet of material **10b** and, in this instance, heat also must be applied to effect the sealing. The term “bonding material” as used herein means any type of material or thing which can be used to effect the bonding or connecting of the two adjacent portions of the sheet of material **10b** to effect the connection or bonding described herein. The term “bonding material” also includes labels, bands, ribbons, strings, tape, staples or combinations thereof. Some of the bonding materials would secure the ends of the sheet of material **10b** while other bonding materials may bind the circumference of a decorative wrapper **36b** formed from the sheet of material **10b**.

[0039] The sheet of material **10b** is wrapped (shown in FIG. 7) about the floral grouping **30** to form the decorative wrapper **36b** in the same manner as described before with respect to wrapping the sheet of material **10** about the floral grouping **30** to form the decorative wrapper **36** as shown in FIG. 4 or the decorative wrapper **36a** as shown in FIG. 5. A portion of the sheet of material **10b** near the second side **14b** thereof overlaps portions of the sheet of material **10b** near the second end **18b** thereof when wrapped about the floral grouping **30** and the bonding material **42** bondingly engages the overlapping

portions of the sheet of material **10b** and bondingly connects the overlapping portions of the sheet of material **10b** to secure the sheet of material **10b** in the form of the decorative wrapper **36b** as shown in FIG. 7. At least a portion of the embossed pattern **24b** and at least a portion of the printed pattern **29b** are visible on an outer peripheral surface **39b** of the decorative wrapper **36b**.

[0040] Sheets of material with bonding material thereon for wrapping about a floral grouping are disclosed in U.S. Pat. No. 5,111,637; issued May 12, 1992, entitled, “Method For Wrapping A Floral Grouping”; U.S. Pat. No. 5,111,638, issued May 12, 1992, entitled, “Method For Wrapping an Object With A Material Having Pressure Sensitive Adhesive Thereon” and U.S. Pat. No. 5,181,364, issued Jan. 26, 1993, entitled, “Wrapping A Floral Grouping With Sheets Having Adhesive or Cohesive Material Applied” and the descriptions in these patents are specifically incorporated herein by reference.

#### Embodiment of FIG. 8

[0041] Shown in FIG. 8 schematically is a system **43** for embossing the sheet of material **10** or **10b** to provide the embossed pattern **24** or **24b** and for printing a color or colors on the sheet of material **10a** or **10b** to provide the printed pattern **29** or **29b**. A roll of material **44** may be constructed of any flexible material capable of being cut into sheets of material and wrapped about a floral grouping. Preferably, the roll of material **44** is constructed of paper, polymeric film, metallized film, foil, or laminations or combinations thereof.

[0042] The roll of material **44** is rollingly supported, and one end of the roll of material **44** is passed between a pair of embossing rollers **46** and **48**. The embossing roller **46** has a plurality of raised portions **50** and a plurality of depressed portions **51** (only one of the raised portions **50** and one of the depressed portions **51** being designated by the reference numerals in FIG. 8). The embossing roller **48** has a plurality of depressed portions **52** and a plurality of raised portions **53** (only one of the depressed portions **52** and one of the raised portions **53** being designated by the reference numerals in FIG. 8). The depressed portions **52** are arranged on the embossing roller **48** to correspond and register with the raised portions **50** on the embossing roller **46**. In a similar manner, the depressed portions **51** are arranged on the embossing roller **46** to correspond and register with the raised portions **53** on the embossing roller **48**.

[0043] An ink roller **54** is disposed near the embossing roller **46**. The ink roller **54** is positioned to apply ink to the raised portions **50** of the embossing roller **46**.

[0044] One end **55** of the roll of material **44** is passed between the embossing rollers **46** and **48** in the direction indicated by the arrow **56**, and the embossing rollers **46** and **48** are rotated in the respective directions indicated by the arrows **58** and **60**. As the roll of material **44** is passed between the embossing rollers **46** and **48**, the raised portions **50** of the embossing roller **46** engage the roll of material **44** and force the roll of material **44** into the corresponding depressed portion **52** of the embossing roller **48**, thereby forming raised and depressed portions, such as the raised portions **26** and depressed portions **28** depicted in the sheet of material **10** (FIGS. 1-3). The ink roller **54** rotates in a direction indicated by the arrow **62** and applies ink to the raised portions **50** of the embossing roller **46**. The raised portions **50** of the embossing roller **46** having the ink thereon transfer the ink to the roll of material **44**, thereby providing the printed pattern **29** by

applying a color to the depressed portions 28 of the sheet of material 10, wherein the printed pattern 29 is provided simultaneously with the forming of the raised portions 26 and depressed portions 28 of the embossed pattern 24 provided on the sheet of material 10. In this manner, the printed pattern 29 is provided in register with the embossed pattern 24.

[0045] A portion of the roll of material 44 then is passed under a knife 64. After a predetermined amount of the roll of material 44 is passed under the knife 64, the knife 64 is moved to engage and cut the sheet of material 10 or 10b from the roll of material 44.

[0046] The embossing rollers 46 and 48 each may be constructed of any suitable material capable of maintaining the raised and depressed portions 50 and 51 of the embossing roller 46 and the depressed and raised portions 52 and 53 of the embossing roller 48. Preferably, however, the embossing rollers 46 and 48 are constructed of a metal. In some instances, an embossing roller 48 constructed of paper may be used and, in this instance, it is not necessary to preform the depressed portions 52 in the embossing roller 48 as the depressed portions 52 will somewhat automatically be formed by the raised portions 50 of the embossing roller 46 engaging the paper embossing roller 48 and depressing the engaged portions of the paper embossing roller 48.

[0047] It should be noted that the ink roller 54 could be positioned to apply ink to the depressed portions 52 of the embossing roller 48 or the corresponding raised portions 53 on the embossing roller 48 if desired in a particular application. Alternatively, the ink roller 54 may not interact with either of the embossing rollers 46 and 48 and may provide the printed pattern 29 to the material by directly interacting with the material withdrawn from the roll of material 44, as discussed in further detail below.

Embodiment of FIG. 9

[0048] Shown in FIG. 9 is a system 65 for forming the embossed pattern 24 or 24b on the respective sheets of material 10 or 10b. The system 65 is similar to the system 43 described hereinbefore with respect to FIG. 8, except as described herein below.

[0049] In the system 65 shown in FIG. 9, an ink roller 54a is disposed upstream of embossing rollers 46a and 48a to apply a color or colors which provide the printed pattern 29 to the roll of material 44 prior to the roll of material 44 being embossed by the embossing rollers 46a and 48a to provide the embossed pattern 24. Otherwise, the system 65 shown in FIG. 9 operates in a manner similar to the system 43 hereinbefore described with reference to FIG. 8.

[0050] It should be noted that the ink roller 54a could be positioned past the embossing rollers 46a and 48a so that the printed pattern 29 is applied to the sheet of material 10 or 10b after the embossed pattern 24 or 24b has been depressed thereon by the embossing rollers 46a and 48a. It also should be noted that an additional ink roller could be included for applying a second printed pattern (not shown) to the opposite surface of the sheet of material 10 or 10b if desired in a particular application.

[0051] By applying the printed pattern 29 prior to or following the embossing of the embossed pattern 24, the printed pattern 29 may be applied in register with the embossed pattern 24 or out of register with the embossed pattern 24. Alternatively, a portion of the printed pattern 29 may be applied in register with the embossed pattern 24,

while a portion of the printed pattern 29 may be applied out of register with the embossed pattern 24.

[0052] Systems for embossing sheets of material are well known in the art, and a detailed description of such systems and the embossing roller or ink rollers used therein is not deemed necessary herein.

[0053] Following application of the printed pattern 29 and the embossed pattern 24 to the roll of material 44, a portion of the roll of material 44 is passed under a knife 64a, and the knife 64a is moved to engage and cut the sheet of material 10 or 10b from the roll of material 44.

Embodiment of FIGS. 10 and 11

[0054] Shown in FIGS. 10 and 11 is a pot cover 66 which is formed from the sheet of material 10 shown in FIG. 1. The pot cover 66 includes a base 68 having an upper end 70, a lower end 72 and an outer peripheral surface 73. An object opening 74 is formed through the upper end 70 of the base 68 of the pot cover 66, and the object opening 74 extends a distance between the upper end 70 and the lower end 72 of the base 68 of the pot cover 66. The object opening 74 is sized to receive a pot or flower pot. A skirt 76 is formed on the upper end 70 of the base 68 of the pot cover 66, and the skirt 76 extends a distance outwardly from the upper end 70 of the base 68 of the pot cover 66.

[0055] At least a portion of the embossed pattern 24 provided on the sheet of material 10 from which the pot cover 66 is constructed is visible on at least one of the outer peripheral surface 73 of the base 68 of the pot cover 66 and the skirt 76 of the pot cover 66. When the sheet of material 10 from which the pot cover 66 is constructed is provided with a decorative printed pattern 29, at least a portion of the decorative printed pattern 29 is visible on the outer peripheral surface 73 of the base 68 and/or the skirt 76b of the pot cover 66.

[0056] The pot cover 66 is formed by placing the sheet of material 10 between a male die and a female die. The dies are brought together with the sheet of material 10 being disposed there between to form the sheet of material 10 into the pot cover 66. During this forming process, a plurality of overlapping folds 80 is formed in the base 68 of the pot cover 66. The overlapping folds 80 extend at various and different distances and at various and different angles over the base 68 of the pot cover 66.

[0057] The system for forming the pot cover 66 is described in detail in U.S. Pat. No. 4,772,183, entitled, "Article Forming System", issued Sep. 27, 1988, the Specification of such patent specifically being expressly incorporated herein by reference.

[0058] As shown in FIG. 11, a flower pot 82 is disposed in the object opening 74 of the pot cover 66. The base 68 of the pot cover 66 covers a substantial portion of an outer peripheral surface 84 of the flower pot 82. The skirt 76 of the pot cover 66 extends a distance outwardly and upwardly from an upper end 86 of the flower pot 82. The flower pot 82 has a floral grouping 30c disposed therein, and the floral grouping 30c extends a distance upwardly from the upper end 86 of the flower pot 82. The pot cover 66 provides a decorative covering 78 for the flower pot 82.

Embodiment of FIGS. 12 and 13

[0059] Shown in FIG. 12 is a modified sheet of material 10d which is constructed similar to the sheet of material 10 shown in FIG. 1, except as described hereinbelow. The sheet of

material **10d** has a first side **12d**, a second side **14d**, a first end **16d**, a second end **18d**, an upper surface **20d** and a lower surface **22d**. At least a portion of at least one of the upper and lower surfaces **20d** and **22d** of the sheet of material **10d** is provided with an embossed pattern **24d**, and at least a portion of at least one of the upper and lower surfaces **20d** and **22d** of the sheet of material **10d** is provided with a printed pattern **29d**. In FIG. 12, the printed pattern **29d** is depicted as disposed on the lower surface **22d** of the sheet of material **10d** and out of register with the embossed pattern **24d**.

[0060] The sheet of material **10d** also includes a plurality of spaced apart spots of bonding material **88** disposed on at least a portion of the upper surface **20d** thereof. It should be noted that in lieu of the spots of bonding material **88**, the bonding material **88** could be applied to at least a portion of the upper surface **20d** of the sheet of material **10d** in the form of strips or any other geometric shape, and the bonding material **88** may be applied only on the raised portions **26d** of the embossed pattern **24d**, or the bonding material **88** may be incorporated in the ink applied to the upper surface **20d** of the sheet of material **10d** in the form of the decorative printed pattern **29**.

[0061] In FIG. 12, the embossed pattern **24d** and the printed pattern **29d** are illustrated as being out of register with one another. However, it will be understood that the embossed pattern **24d** and the printed pattern **29d** may be in register with one another, or a portion of the embossed pattern **24d** may be in register with the printed pattern **29d** and a portion of the embossed pattern **24d** may be out of register with the printed pattern **29d**.

[0062] In operation, the flower pot **82** is placed on the upper surface **20d** of the sheet of material **10d**. In this position, the sheet of material **10d** is formed about the outer peripheral surface **84** of the flower pot **82** (shown in FIG. 13) such that the sheet of material **10d** substantially encompasses and covers the outer peripheral surface **84** of the flower pot **82**, thereby providing a decorative covering **87** for the flower pot **82**. The bonding material **88** is brought into engagement with the outer peripheral surface **84** of the flower pot **82** as the sheet of material **10d** is formed about the flower pot **82** to provide the decorative covering **87**. The bonding material **88** bondingly engages the outer peripheral surface **84** of the flower pot **82** so as to bondingly connect the sheet of material **10d** to the outer peripheral surface **84** of the flower pot **82**. As the sheet of material **10d** conforms to the shape of the outer peripheral surface **84** of the flower pot **82**, a base portion **89** of the decorative covering **87** is formed. A portion of the sheet of material **10d** extends outwardly and upwardly from the upper end **86** of the flower pot **82** to form a skirt portion **91** of the decorative covering **87** formed from the sheet of material **10d**.

[0063] It also should be noted that the bonding material **88** may be applied to the lower surface **22d** of the sheet of material **10d**. In this instance, the sheet of material **10d** would be applied to the flower pot **82** in a manner similar to that described before, except the flower pot **82** would be adjacent the lower surface **22d** of the sheet of material **10d** such that the lower surface **22d** would be positioned adjacent the outer peripheral surface **84** of the flower pot **82**.

Embodiment of FIGS. 14, 14a, 15, 16 and 17

[0064] Shown in FIG. 14 is a sleeve **90** for a flower pot or floral grouping, the sleeve **90** constructed from the sheet of material **10** having printed and embossed patterns **29** and **24**, respectively, as shown in FIG. 1 and described in detail

before. The sleeve **90** has an upper end **92** and a lower end **94**. The sleeve **90** is frusto-conically shaped and has an opening **96** extending therethrough intersecting the upper end **92** and the lower end **94** thereof.

[0065] The sleeve **90** may be constructed by taking the sheet of material **10** shown in FIG. 1 and cutting the sheet of material **10** in the form of two trapezoidally shaped sheets and then connecting the two sheets together along two edges of each sheet to form the frusto-conically shaped sleeve **90** shown in FIG. 14. In the alternative, two rolls of material having the embossed pattern **24** and the printed pattern **29** thereon may be connected at spaced apart places to form the frusto-conically shaped sleeves **90**, and then the formed frusto-conically shaped sleeves **90** may then be separated from the combined materials. There are various commercially available methods for forming sleeves such as the sleeve **90**, and any of these commercially available methods or systems can be used to form the sleeve **90**. These prior art systems for forming the sleeve **90** are well known in the art, and a detailed description of the apparatus and methods for forming the sleeve **90** is not deemed necessary herein.

[0066] Shown in FIG. 14a is a sleeve **90a** similar to the sleeve **90** shown in FIG. 14 and described hereinbefore, except that a lower end **94a** of the sleeve **90a** is closed, thereby forming a closed bottom **95** of the sleeve **90a**. While the uses of sleeve **90** will be described in detail hereinafter, it will be understood that sleeve **90a** may be used in a similar manner.

[0067] As shown in FIG. 15, the flower pot **82** with the floral grouping **30c** disposed therein is disposed in the opening **96** of the sleeve **90**. The flower pot **82** is positioned near the lower end **94** of the sleeve **90**, and the sleeve **90** substantially encompasses the outer peripheral surface **84** of the flower pot **82**, except for a bottom **97** of the flower pot **82** which is disposed adjacent the open lower end **94** of the sleeve **90**. A portion of the sleeve **90** also encompasses and surrounds the floral grouping **30c** disposed in the flower pot **82**. Preferably, a portion of the sleeve **90** extends above the bloom end **34c** of the floral grouping **30c**. The sleeve **90** provides a protective and a decorative covering **99** for the flower pot **82** and the floral grouping **30c** disposed therein.

[0068] While the use of the sleeve **90** to provide a decorative covering **99** for the flower pot **82** has been described herein, it will be understood that the sleeve **90** may also be employed to provide a decorative covering for a floral grouping in a substantially similar manner as that described above in reference to providing the decorative covering **99** for the flower pot **82**.

[0069] Shown in FIG. 16 is a modified sleeve **90e** which is constructed similar to the sleeve **90** shown in FIG. 14 and described in detail before, except the sleeve **90e** is smaller than the sleeve **90** shown in FIG. 14 in that the distance between an upper end **92e** and a lower end **94e** of the sleeve **90e** is less than the distance between the upper and lower ends **92** and **94** of the sleeve **90**. The sleeve **90e** is positioned over and encompasses only the bloom end **34c** of the floral grouping **30c** disposed in the flower pot **82** to provide a protective and a decorative covering **99e** for the bloom end **34c** of the floral grouping **30c** with the bloom end **34c** being disposed in an opening **96e** of the sleeve **90e**.

[0070] Shown in FIG. 17 is another modified sleeve **90f** which is constructed similar to the sleeve **90e** shown in FIG. 16, except the sleeve **90f** is sized to surround and encompass the flower pot **82** rather than surrounding the bloom end **34c**

of the floral grouping **30c** disposed in the flower pot **82**. The sleeve **90f** is sized to encompass substantially only the outer peripheral surface **84** of the flower pot **82** in such a manner that the floral grouping **30c** disposed in the flower pot **82** is clearly visible, thereby providing a decorative covering **99f** for the flower pot **82**.

#### Embodiment of FIG. 18

[0071] Shown in FIG. 18 is a pad **98** of sheets of material **10**, **10b** or **10d** with each of the sheets of material **10**, **10b** or **10d** being constructed in a manner like that described before with respect to FIG. 1, 6 or 12. In those instances where the sheets of material **10**, **10b** or **10d** in the pad **98** are constructed like the sheet of material **10b** or **10d** shown in FIG. 6 or 12, the bonding material **42** or **88** bondingly and releasably connects each of the sheets of material **10b** or **10d** to the adjacent sheet of material **10b** or **10d** to form the pad **98**. The sheets of material **10**, **10b** or **10d** are disconnected or removed from the pad **98** and wrapped about the floral grouping **30** or the flower pot **82** in the manner described before with respect to FIGS. 1, 3-7 and 12-13. A pad of sheets of material for wrapping about floral groupings is disclosed and described in detail in U.S. Pat. No. 5,181,364, referred to before and expressly incorporated herein by reference.

#### Embodiment of FIGS. 19-21

[0072] Shown in FIG. 19 is a roll of material **100** containing a plurality of sheets of material, such as the sheet of material **10**, **10b** or **10d**, separated by lines of perforations **102**. In this embodiment, the material is unrolled from the roll of material **100** and the sheets of material **10**, **10b** or **10d** are separated from the roll of material **100** by tearing along the lines of perforations **102**.

[0073] Shown in FIG. 20 is a roll of material **100a** which is constructed similar to the roll of material **100** shown in FIG. 19, except the roll of material **100a** does not include the lines of perforations **102**. In this embodiment, the material is unrolled from the roll of material **100a** and, after a predetermined amount of material has been unrolled from the roll of material **100a**, a knife **104** is activated or manually manipulated to cut the material from the roll of material **100a** thereby separating a sheet of material **10**, **10b** or **10d** from the roll of material **100a**. The separated sheet of material **10**, **10b** or **10d** is constructed similar to the sheets of material hereinbefore described with reference to FIG. 1, 6 or 12, for example.

[0074] Shown in FIG. 21 is another roll of material **100b** containing a plurality of sheets of material similar to the sheet of material **10**, **10b** or **10d** described herein before with respect to FIG. 1, 6 or 12. The roll of material **100b** is constructed similar to the roll of material **100a** shown in FIG. 20 and described in detail before. The material is unrolled from the roll of material **100b** and passed through an adhesive applicator **106** where a bonding material is applied to the material to form a sheet of material containing a bonding material disposed on one surface thereof such as the sheet of material **10b** having the bonding material **42** disposed on the upper surface **20d** thereof or the sheet of material **10d** having the bonding material **88** disposed on the upper surface **20d** thereof, as described hereinbefore with reference to FIGS. 6 and 12, respectively. The material further is unrolled from the roll of material **100b** and, after a predetermined amount of material has been unrolled from the roll of material **100b**, the

knife **104** is activated or manually manipulated to cut a sheet of material, such as the sheets of material **10b** and **10d**, from the roll of material **100b**.

[0075] Changes may be made in the steps or the sequence of steps of the methods described herein without departing from the spirit and scope of the invention as defined in the following claims.

What is claimed is:

1. A method for providing a decorative covering for a flower pot comprising:
  - providing a sheet of material having a first surface and a second surface, the sheet of material having an embossed pattern disposed on at least a portion of the first surface thereof and a printed pattern disposed on at least a portion of the second surface thereof, wherein the printed and embossed patterns are in register with one another, the sheet of material being selected from the group consisting of paper, polymeric film, metallized film, foil, laminations thereof and combinations thereof;
  - providing a flower pot having an upper end, a lower end and an outer peripheral surface;
  - forming the sheet of material about the outer peripheral surface of the flower pot to provide the decorative covering wherein at least a portion of the embossed pattern and at least a portion of the printed pattern are visible on the decorative covering; and
  - securing the sheet of material about the flower pot via a bonding material.
2. The method of claim 1 wherein the step of providing the sheet of material is further defined as comprising the steps of:
  - providing a roll of material;
  - unrolling material from the roll of material until a predetermined amount of material has been unrolled from the roll of material; and
  - cutting the unrolled material from the roll of material to provide the sheet of material.
3. The method of claim 1 wherein the step of providing the sheet of material is further defined as comprising the steps of:
  - providing a pad of sheets of material wherein the sheets of material are bondingly connected to form the pad; and
  - disconnecting one sheet of material from the pad to provide the sheet of material.
4. The method of claim 1 wherein, in the step of securing the sheet of material about the flower pot, the bonding material is disposed on at least a portion of the sheet of material.
5. The method of claim 1 wherein, in the step of securing the sheet of material about the flower pot, the bonding material is disposed on at least a portion of the flower pot.
6. The method of claim 1 wherein, in the step of securing the sheet of material about the flower pot, the bonding material is selected from the group consisting of adhesive, cohesive, bands, ribbons, strings, tape, staples and combinations thereof.
7. A method for providing a decorative covering for a flower pot comprising:
  - providing a roll of material having a first surface and a second surface, the roll of material having an embossed pattern disposed on at least a portion of the first surface thereof and a printed pattern disposed on at least a portion of the second surface thereof, the roll of material being selected from the group consisting of paper, polymeric film, metallized film, foil, laminations thereof and combinations thereof;

unrolling material from the roll of material until a predetermined amount of material has been unrolled from the roll of material;

cutting the unrolled material from the roll of material to provide a sheet of material having a first surface and a second surface, and having an embossed pattern disposed on at least a portion of the first surface thereof and a printed pattern disposed on at least a portion of the second surface thereof;

providing a flower pot having an upper end, a lower end and an outer peripheral surface;

forming the sheet of material about the outer peripheral surface of the flower pot to provide the decorative covering wherein at least a portion of the embossed pattern and at least a portion of the printed pattern are visible on the decorative covering; and

securing the sheet of material about the flower pot via a bonding material.

**8.** The method of claim 7 wherein, in the step of securing the sheet of material about the flower pot, the bonding material is disposed on at least a portion of the sheet of material.

**9.** The method of claim 7 wherein, in the step of securing the sheet of material about the flower pot, the bonding material is disposed on at least a portion of the flower pot.

**10.** The method of claim 7 wherein, in the step of securing the sheet of material about the flower pot, the bonding material is selected from the group consisting of adhesive, cohesive, bands, ribbons, strings, tape, staples and combinations thereof.

**11.** The method of claim 7 wherein, in the step of providing a roll of material, the printed and embossed patterns are in register with one another.

**12.** The method of claim 7 wherein, in the step of providing a roll of material, the printed and embossed patterns are out of register with one another.

**13.** A method for providing a decorative covering for a flower pot comprising:

providing a pad of sheets of material wherein the sheets of material are bondingly connected to form the pad, each

of the sheets of material having a first surface and a second surface, and having an embossed pattern disposed on at least a portion of the first surface thereof and a printed pattern disposed on at least a portion of the second surface thereof, and each of the sheets of material being selected from the group consisting of paper, polymeric film, metallized film, foil, laminations thereof and combinations thereof;

disconnecting one sheet of material from the pad to provide the sheet of material;

providing a flower pot having an upper end, a lower end and an outer peripheral surface;

forming the sheet of material about the outer peripheral surface of the flower pot to provide the decorative covering wherein at least a portion of the embossed pattern and at least a portion of the printed pattern are visible on the decorative covering; and

securing the sheet of material about the flower pot via a bonding material.

**14.** The method of claim 13 wherein, in the step of securing the sheet of material about the flower pot, the bonding material is disposed on at least a portion of the sheet of material.

**15.** The method of claim 13 wherein, in the step of securing the sheet of material about the flower pot, the bonding material is disposed on at least a portion of the flower pot.

**16.** The method of claim 13 wherein, in the step of securing the sheet of material about the flower pot, the bonding material is selected from the group consisting of adhesive, cohesive, bands, ribbons, strings, tape, staples and combinations thereof.

**17.** The method of claim 13 wherein, in the step of providing a roll of material, the printed and embossed patterns are in register with one another.

**18.** The method of claim 13 wherein, in the step of providing a roll of material, the printed and embossed patterns are out of register with one another.

\* \* \* \* \*