

(No Model.)

2 Sheets—Sheet 1.

J. H. CLARK.
ELECTRIC MOTOR.

No. 526,686.

Patented Oct. 2, 1894.

FIG. 1.

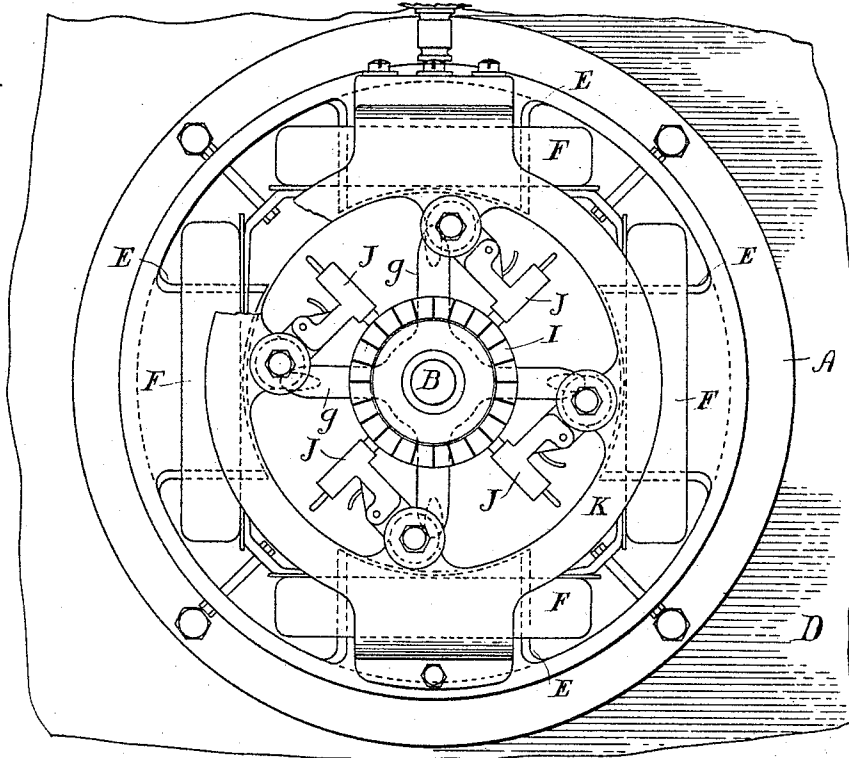

FIG. 3.

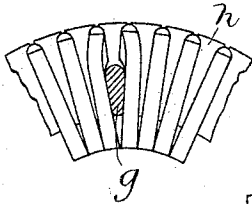
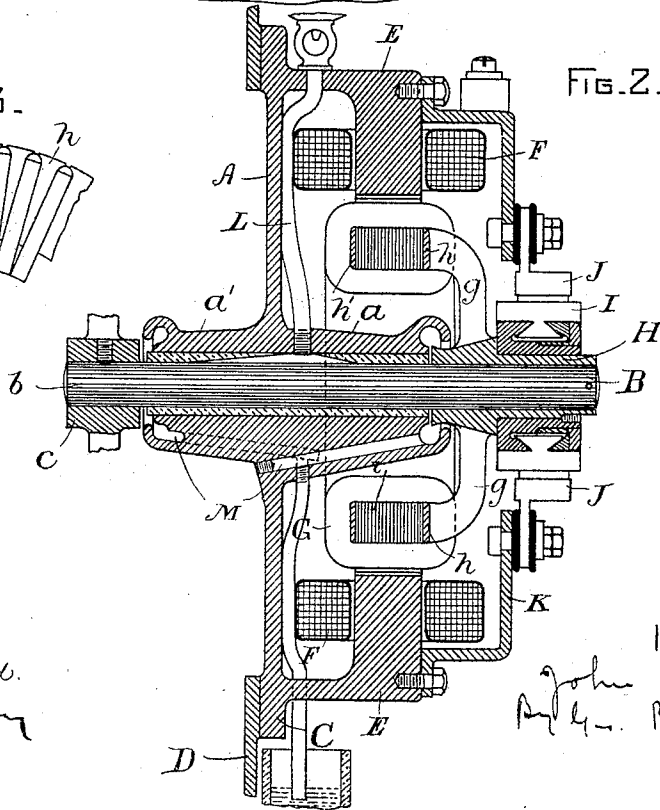

FIG. 2.



WITNESSES.

A. F. Macdonald.

E. W. Cady

INVENTOR-

John H. Clark
By R. B. Hodgkiss
Atty.

(No Model.)

2 Sheets—Sheet 2.

J. H. CLARK.
ELECTRIC MOTOR.

No. 526,686.

Patented Oct. 2, 1894.

FIG. 4.

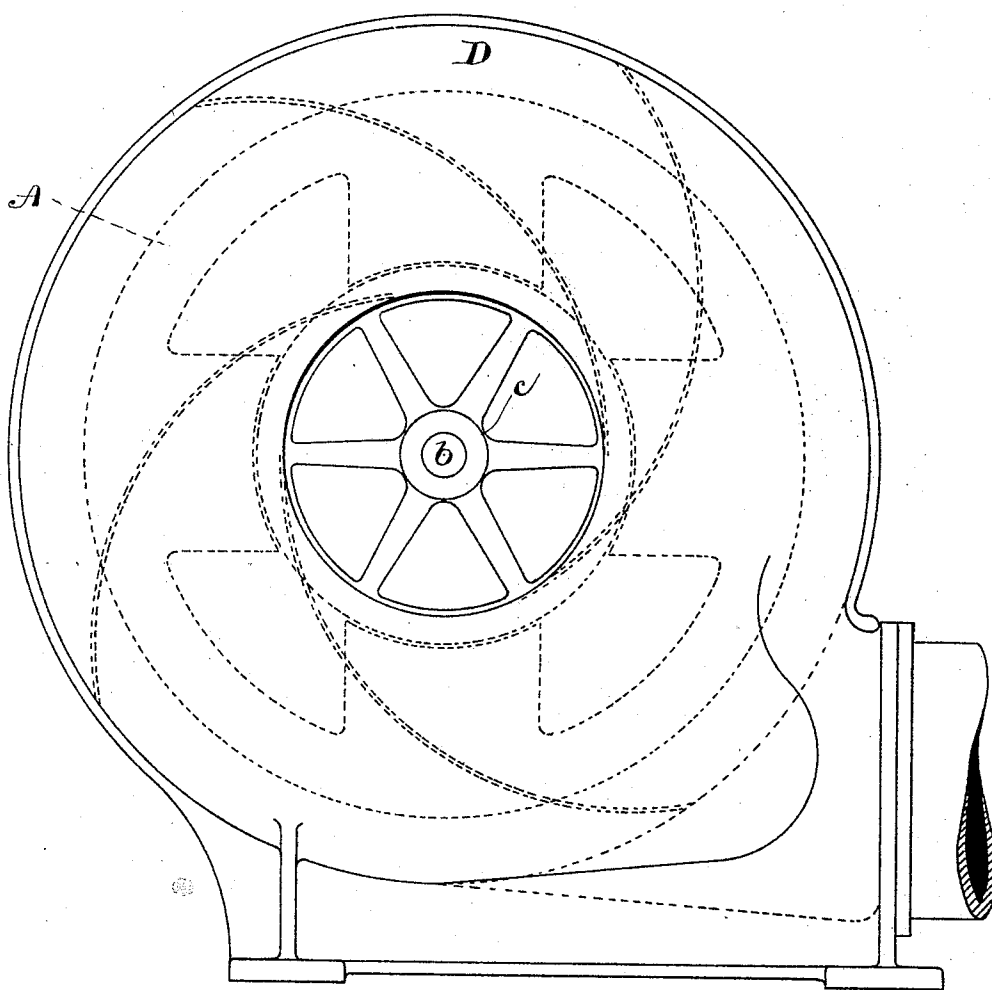

WITNESSES.

A. F. Macdonald.

D. B. Hill.

INVENTOR—

John H. Clark.

By Geo. R. Blodgett
Att'y.

UNITED STATES PATENT OFFICE.

JOHN H. CLARK, OF BOSTON, MASSACHUSETTS, ASSIGNOR TO THE GENERAL ELECTRIC COMPANY, OF NEW YORK.

ELECTRIC MOTOR.

SPECIFICATION forming part of Letters Patent No. 526,686, dated October 2, 1894.

Application filed April 16, 1894. Serial No. 507,653. (No model.)

To all whom it may concern:

Be it known that I, JOHN H. CLARK, a citizen of the United States, residing at Boston, county of Suffolk, State of Massachusetts, have invented a new and useful Improvement in Electric Motors, of which the following is a specification.

My invention relates to the driving of ventilating fans or blowers by electric motors; and my object is to produce a compact and efficient arrangement and construction for this purpose.

My invention consists in the novel construction and arrangement of parts as hereinafter set forth and claimed.

In the accompanying drawings,—Figure 1 is an end view of a motor, its frame, and a portion of the blower casing to which the motor frame is attached. Fig. 2 is a transverse section of the parts shown in Fig. 1; and Fig. 3 is a detail enlarged view of a portion of the coils of the armature and one of the arms of the armature in section. Fig. 4 is a view in elevation of a blower, its revolving fan, and the frame of the electric motor forming the back of the fan casing.

A is a casting forming a part of the frame of the motor and constructed with the hub *a*, provided with the portion *a'*, projecting from the back of the casting A into the blower chamber, and serving as a bearing for the shaft B, on the projecting end *b* of which is mounted the hub *c* of a fan. The casting A is also constructed with a flange C by means of which it is fastened to the edge of an opening in the casing D of the blower. The casting A is further formed with L-shaped projections E, turned down to extend parallel with the back of casing A and forming the poles on which are mounted the coils F of the field magnets. A ring armature G is mounted on the shaft B by means of arms *g* projecting radially from a sleeve H secured to shaft B, curved at their outer ends, projecting through the coils of the armature and secured to an annular plate *h*, as shown in Fig. 3, between which annular plate and an annular plate *h'*, are clamped the laminæ *i* of the armature.

I indicates the commutator and J the commutator brushes which are mounted on the circular ring K secured to the L-shaped projections of the casting A.

L and M are oil pipes leading through the casting A and its hub to the shaft B. By means of this construction and arrangement of the parts of the motor and its casing, the whole is located flat against the side of the blower and the motor shaft has a bearing throughout its length.

The advantages of the construction and arrangement hereinbefore set forth, are as follows: The parts of the motor and its frame are compactly located adjacent to the blower, thereby economizing in space and the extended hub of the casting A serves to afford an additional and solid bearing for the shaft B in carrying both the fan, the armature and the commutator.

What I claim is—

1. In an electric motor, a casting for the motor frame formed with a back or wall having a hub projecting on each side of the back and L-shaped projections forming the poles of the field magnets as set forth.

2. The combination with a blower of an electric motor and its frame formed with a back or wall secured to the blower casing, a hub projecting from the back of the frame on each side thereof, and serving as a continuous bearing for the shaft of the motor and fan, and L-shaped projections extending parallel with the back of the frame and forming the poles of the field magnets, as set forth.

3. In an electric motor, a casting forming the back of the frame and provided with a securing flange, and L-shaped projections extending parallel with said backs forming the poles of the field magnets.

4. The combination with a blower, of an electric motor having a frame, consisting of a casting formed with a back having a flange by which the motor is secured to the blower casing, a hub projecting on either side of the frame back, L-shaped projections extending parallel with the frame back, and forming the poles of the field magnets, a shaft extending through the hub, a fan mounted on a

sleeve secured to the shaft, curved at their
outer ends, projecting through the coils of the
ring armature and secured to one of the clamp-
ing ring plates of the armature, a commutator
5 mounted on said sleeve, and commutator
brushes mounted on brackets secured to the
field magnets, as set forth.

In witness whereof I have hereunto set my
hand this 11th day of April, 1894.

JOHN H. CLARK.

Witnesses:

B. B. HULL,
C. L. HAYNES.