



US 20150032146A1

(19) **United States**  
(12) **Patent Application Publication**  
**Janardhan et al.**

(10) **Pub. No.: US 2015/0032146 A1**  
(43) **Pub. Date: Jan. 29, 2015**

(54) **VARIABLELY HEAT-TREATED TUBULAR DEVICES**

(52) **U.S. Cl.**  
CPC ..... *A61F 2/01* (2013.01)  
USPC ..... **606/200**

(71) Applicant: **Insera Therapeutics, Inc.**, Sacramento, CA (US)

(72) Inventors: **Vallabh Janardhan**, Dallas, TX (US);  
**Vikram Janardhan**, Sacramento, CA (US)

(73) Assignee: **Insera Therapeutics, Inc.**, Sacramento, CA (US)

(21) Appl. No.: **14/224,637**

(22) Filed: **Mar. 25, 2014**

**Related U.S. Application Data**

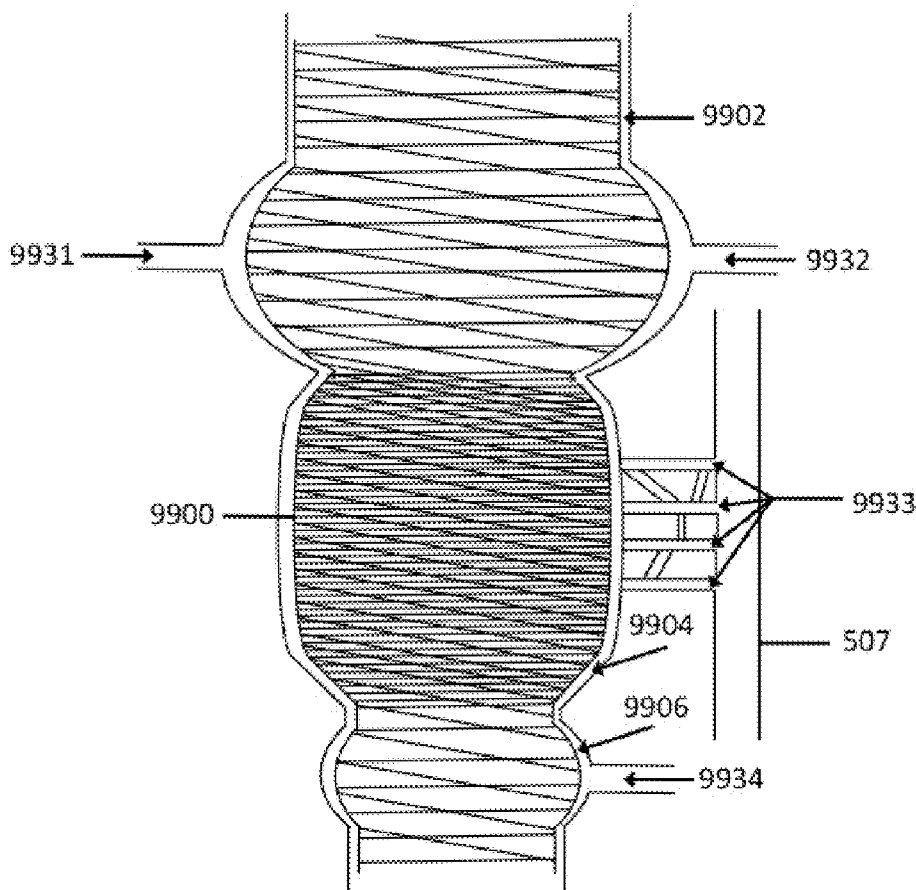
(63) Continuation of application No. 13/953,540, filed on Jul. 29, 2013, now Pat. No. 8,715,314.

**Publication Classification**

(51) **Int. Cl.**  
*A61F 2/01* (2006.01)

(57) **ABSTRACT**

A vascular device may include a tubular element. The tubular element may include a plurality of longitudinal sections. The plurality of longitudinal sections may include a first longitudinal section having a first austenitic finish temperature and a second longitudinal section having a second austenitic finish temperature different than the first austenitic finish temperature. The first longitudinal section may include a first material. The second longitudinal section may include a second material different than the first material. The first longitudinal section may include a first shape set. The second longitudinal section may include a second shape set different than the first shape set. The first longitudinal section may be configured to provide torquability. The second longitudinal section may be configured to provide flexibility. At least one of the first longitudinal section and the second longitudinal section may be shape set to a straight configuration. The tubular element may include a pattern.



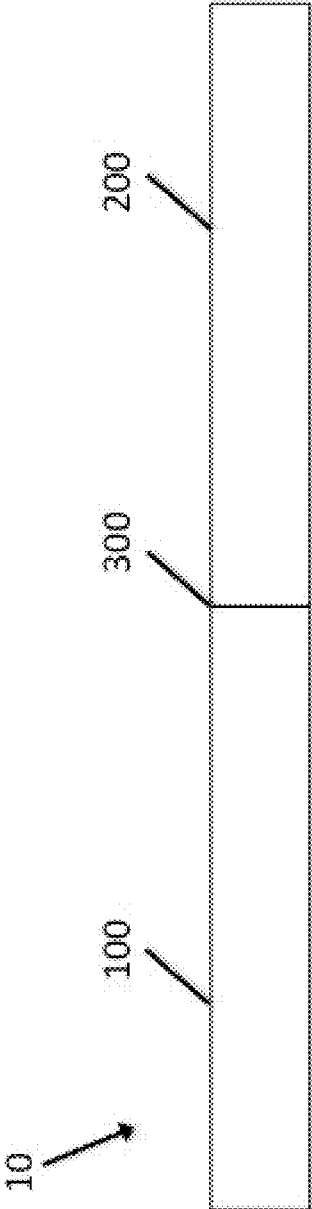


Fig. 1A

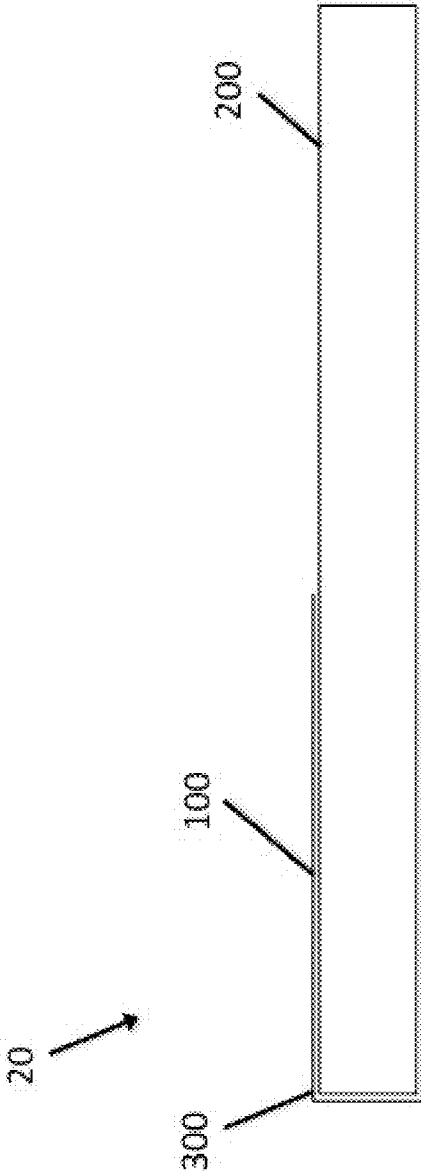


FIG. 1B

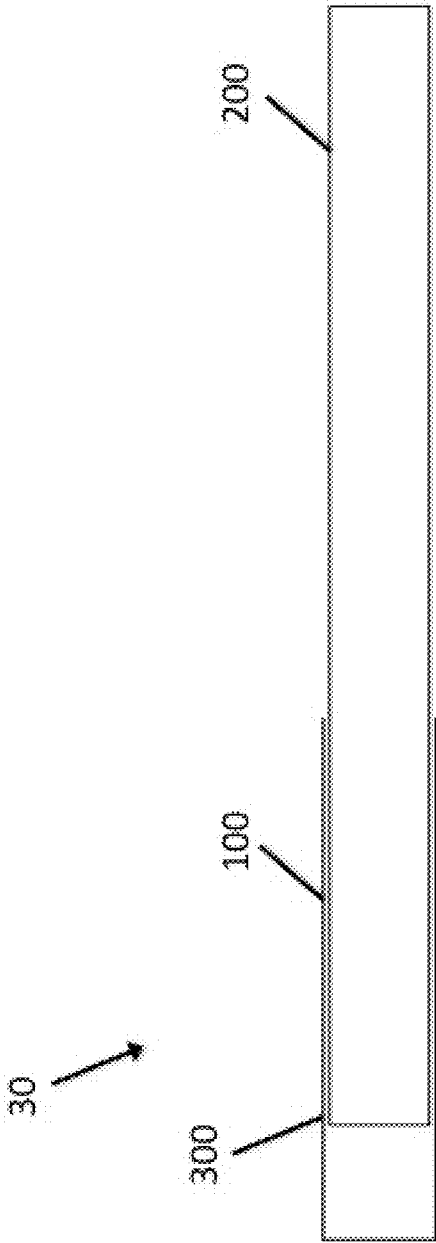


Fig. 1C

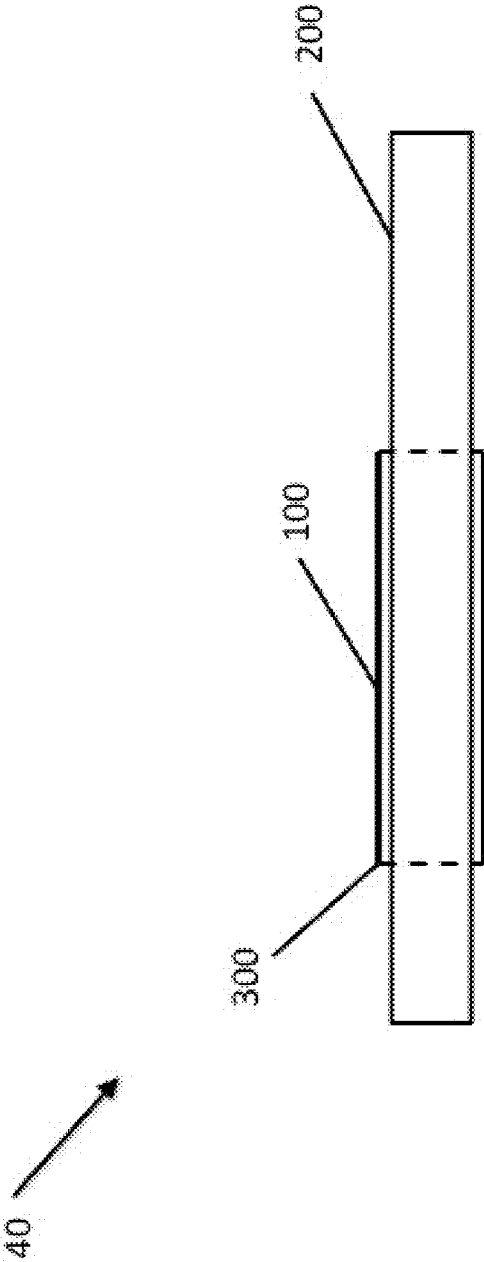


FIG. 1D

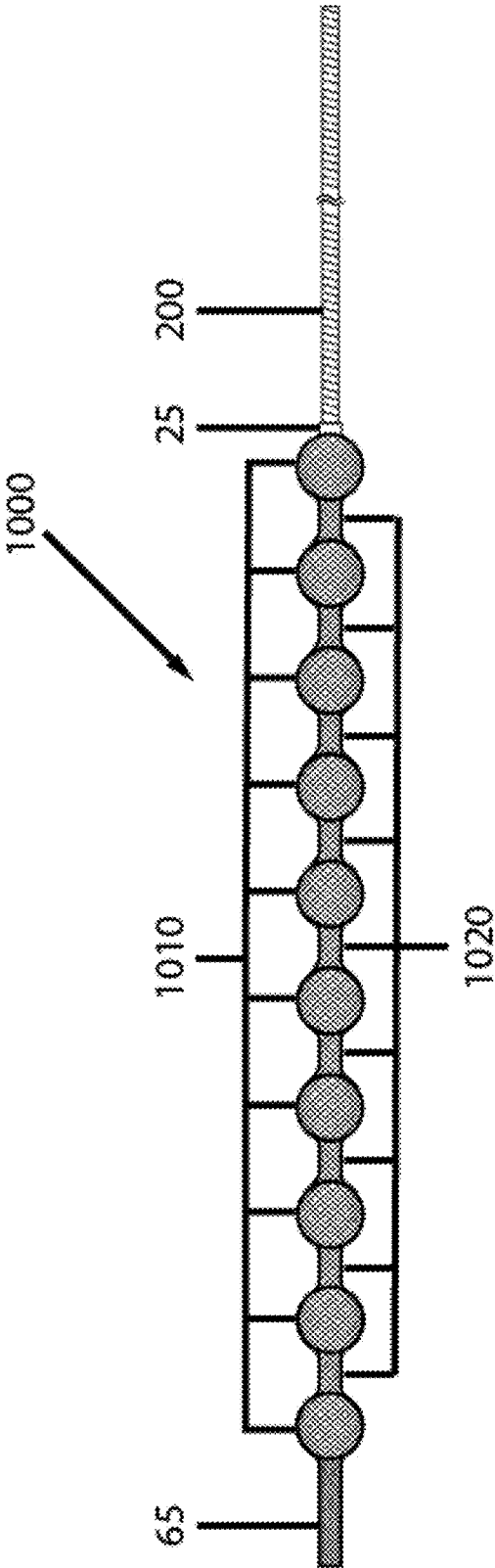


Fig. 2A

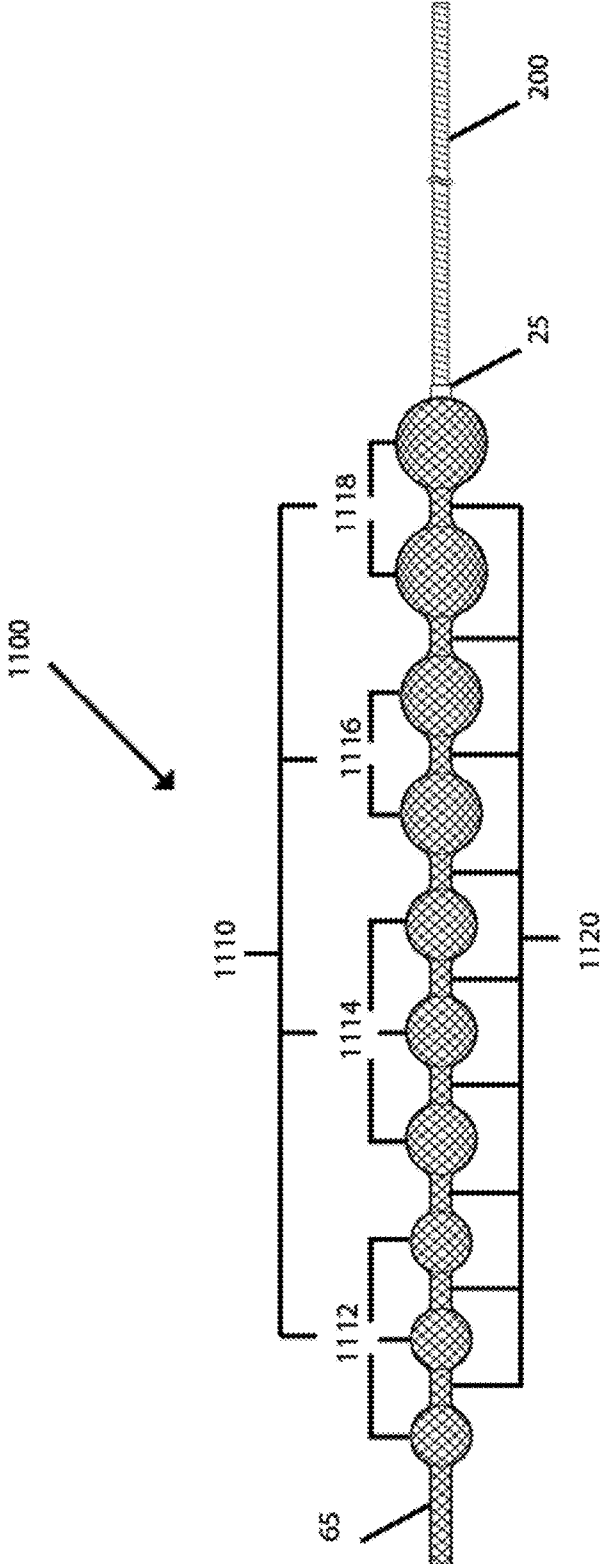


Fig. 2B

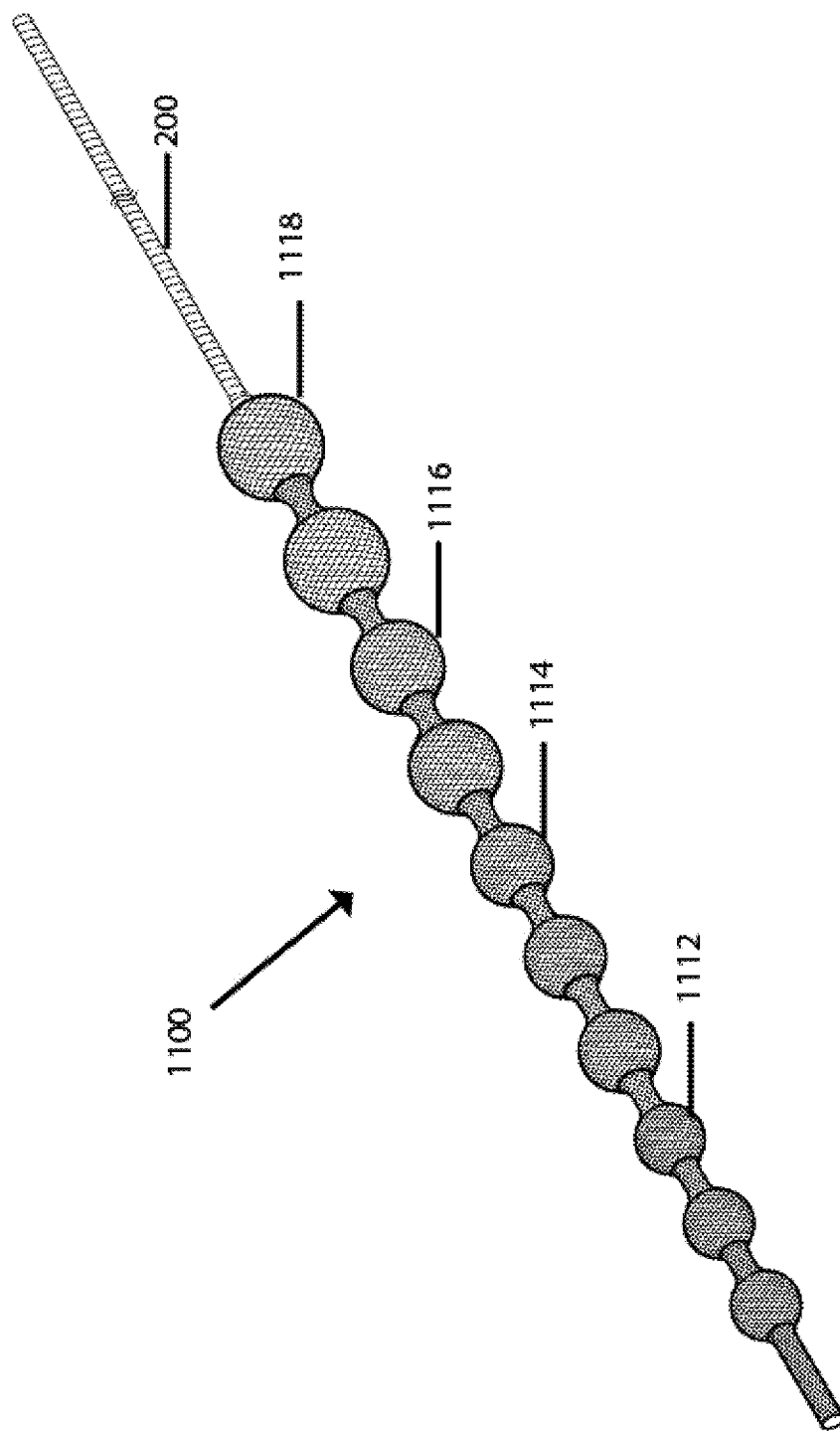
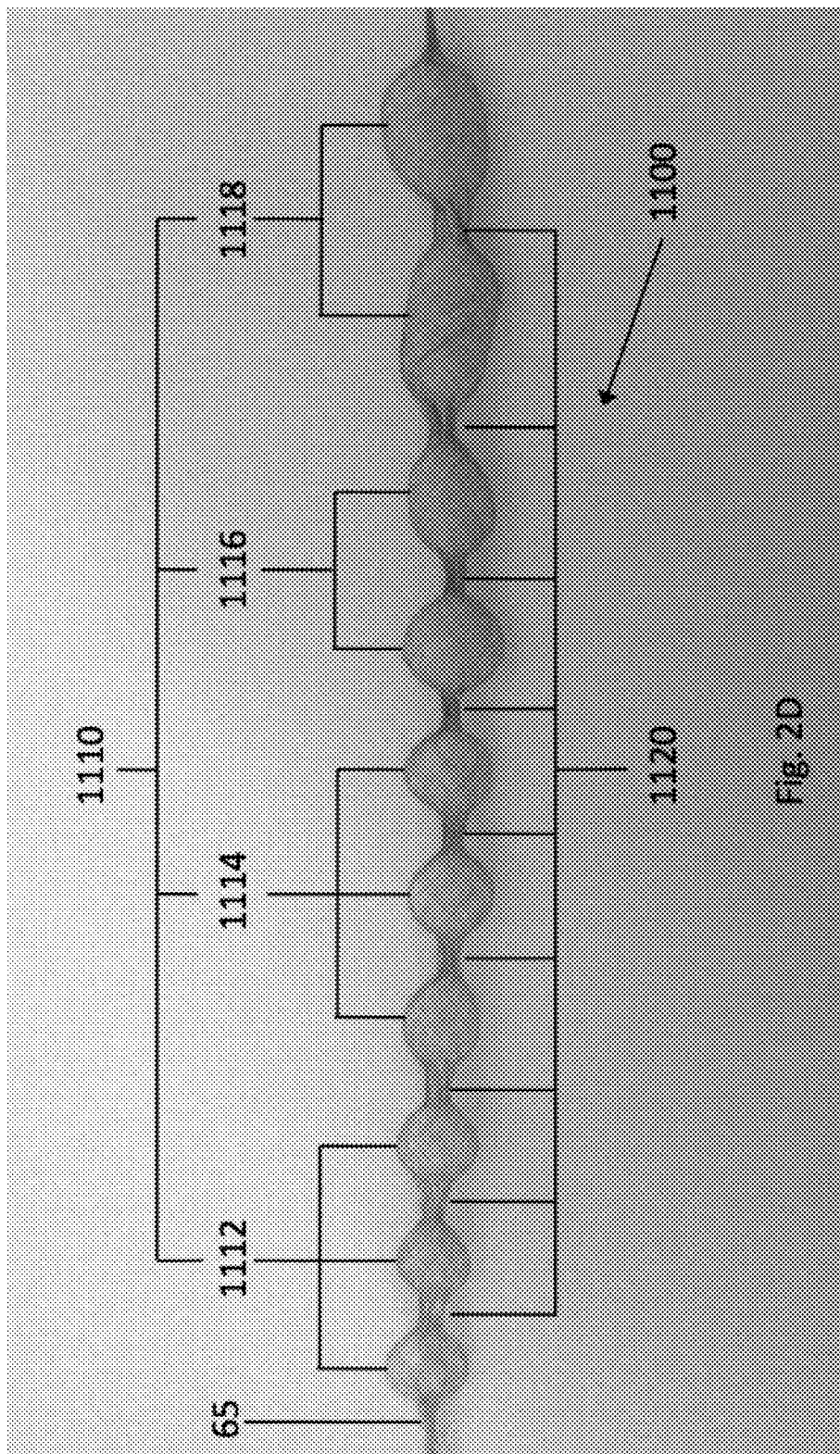


Fig. 2C





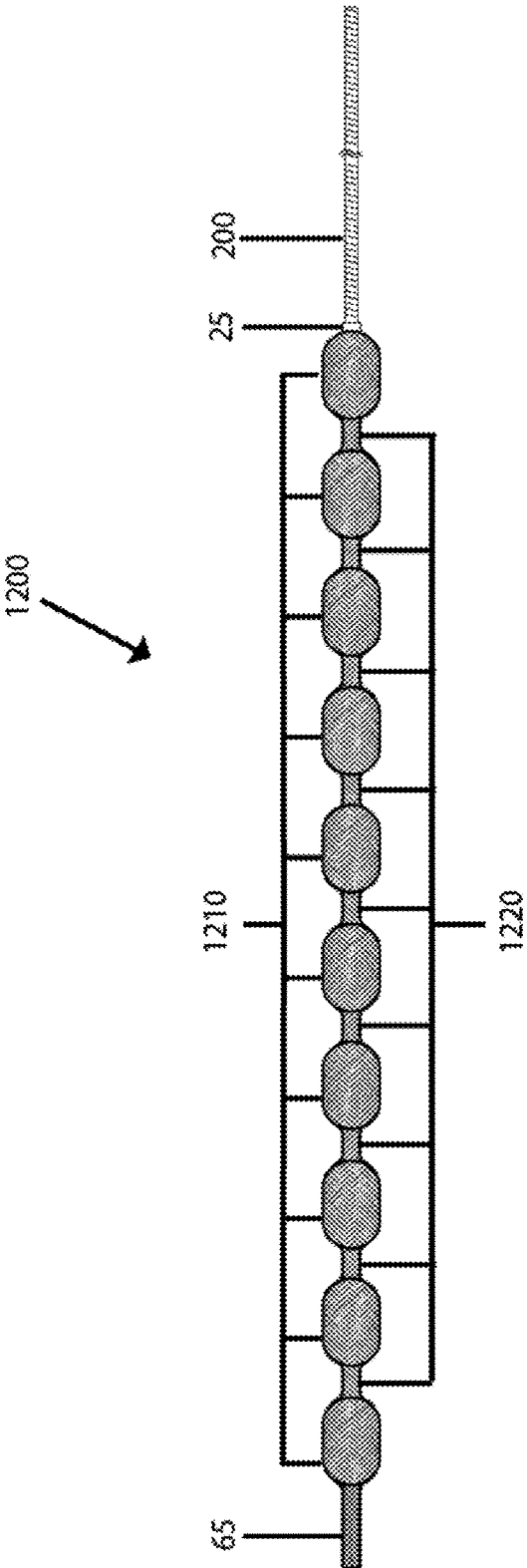


Fig. 3A

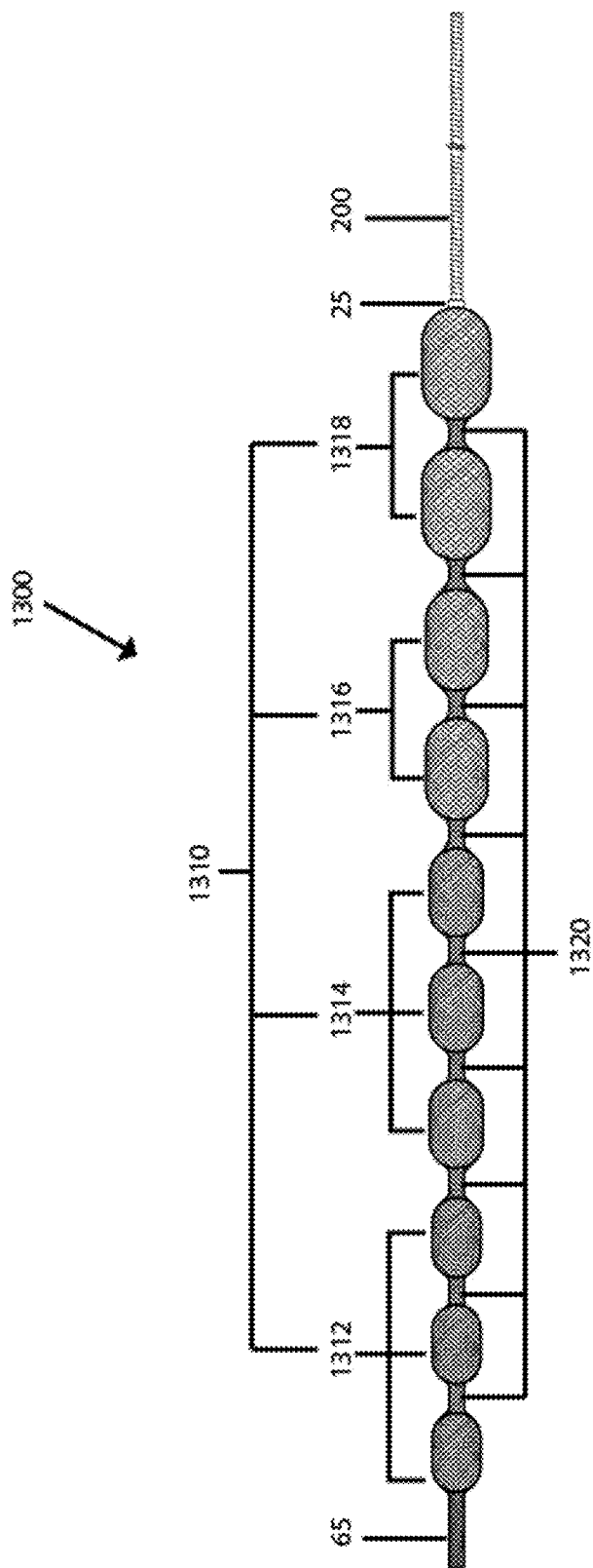


Fig. 3B

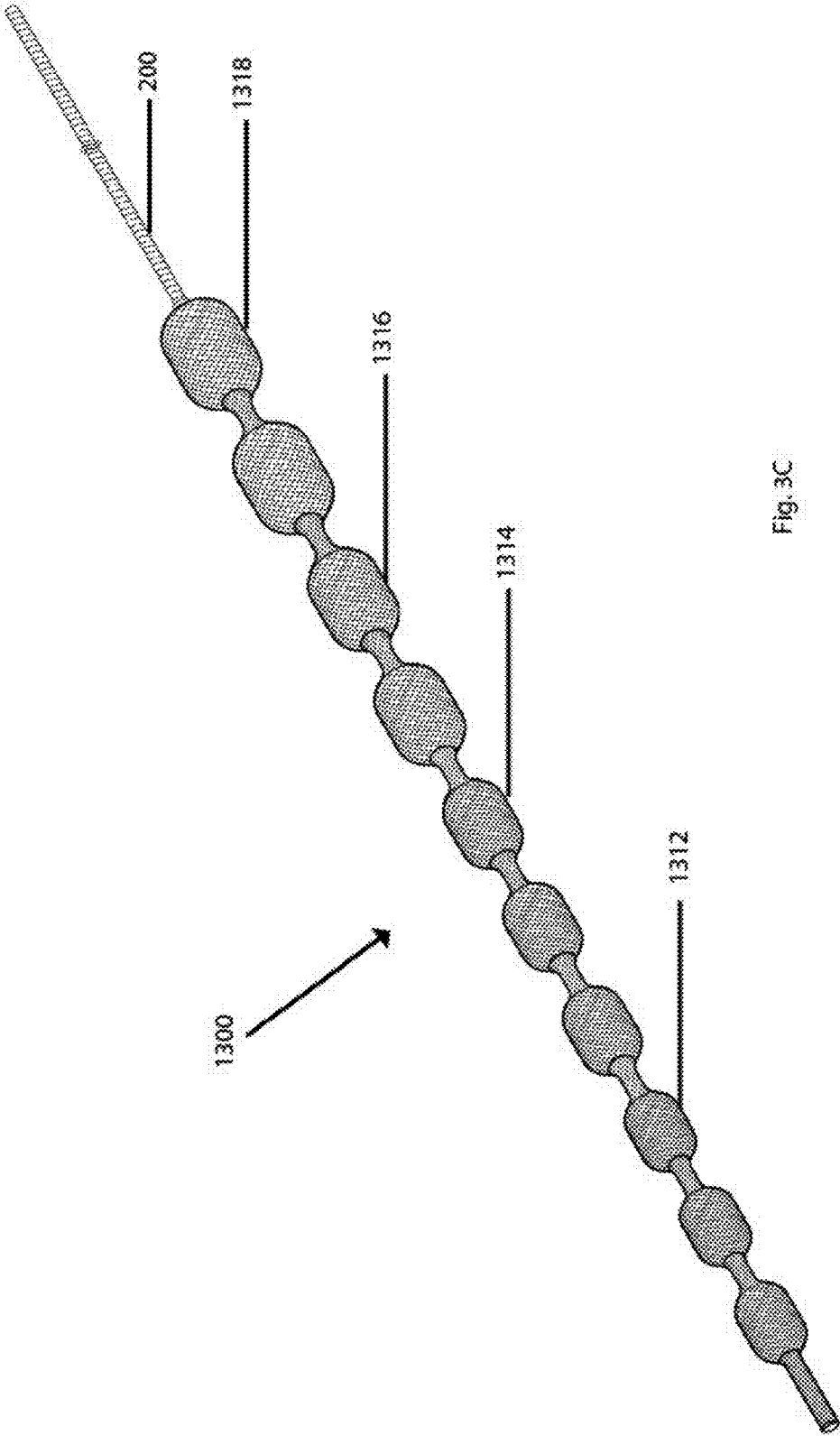


Fig. 3C

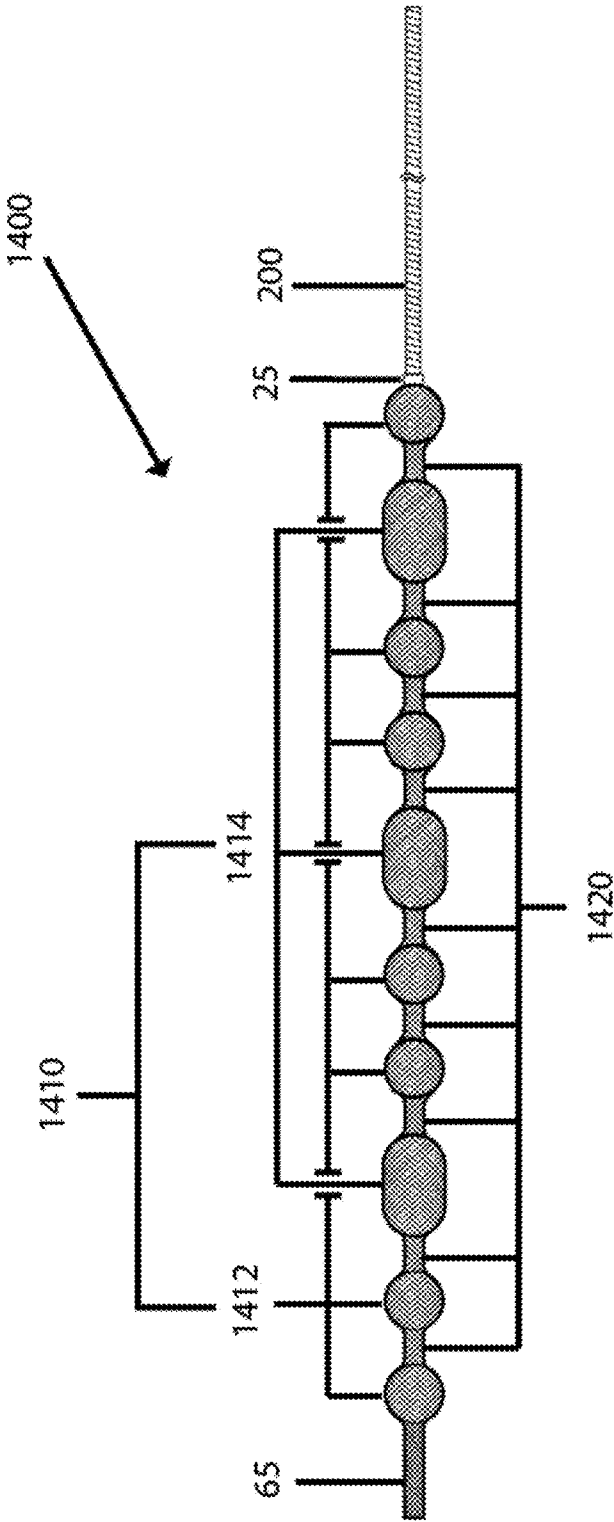


Fig. 4A

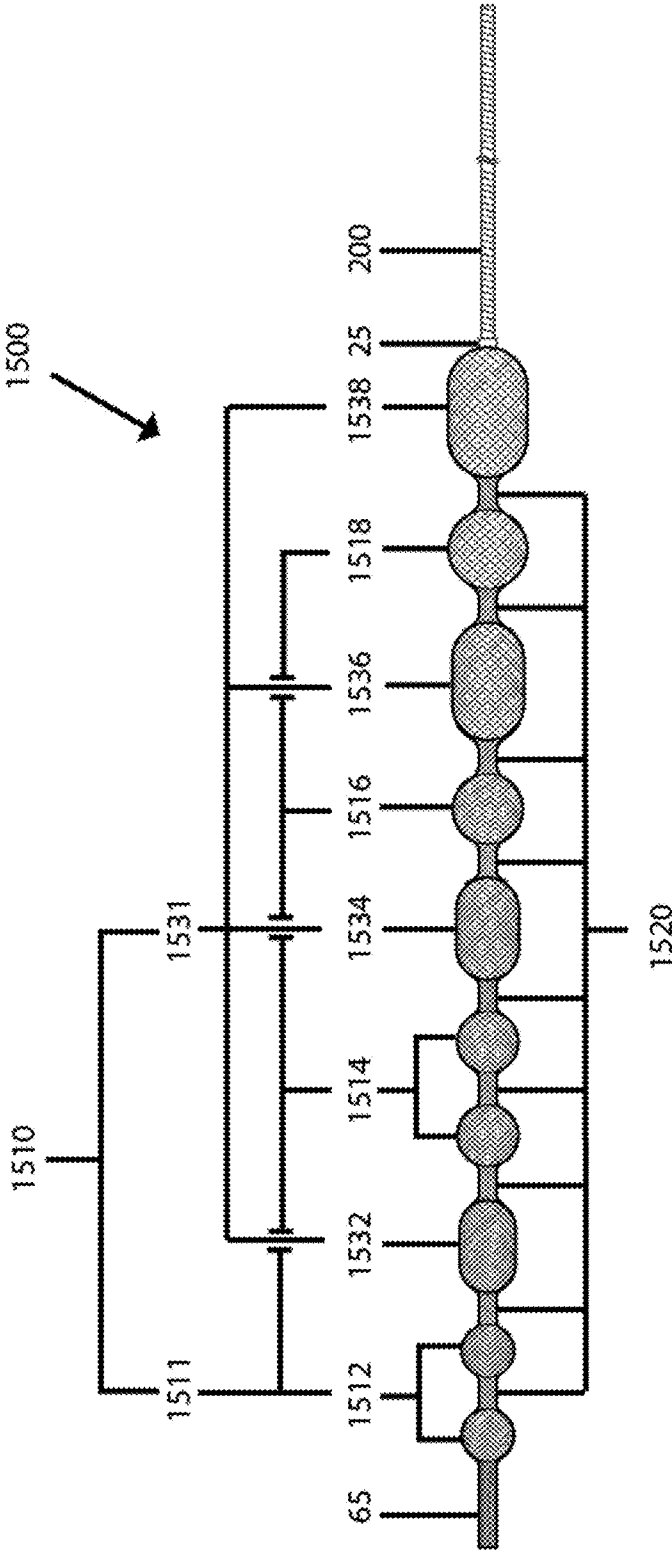


Fig. 4B

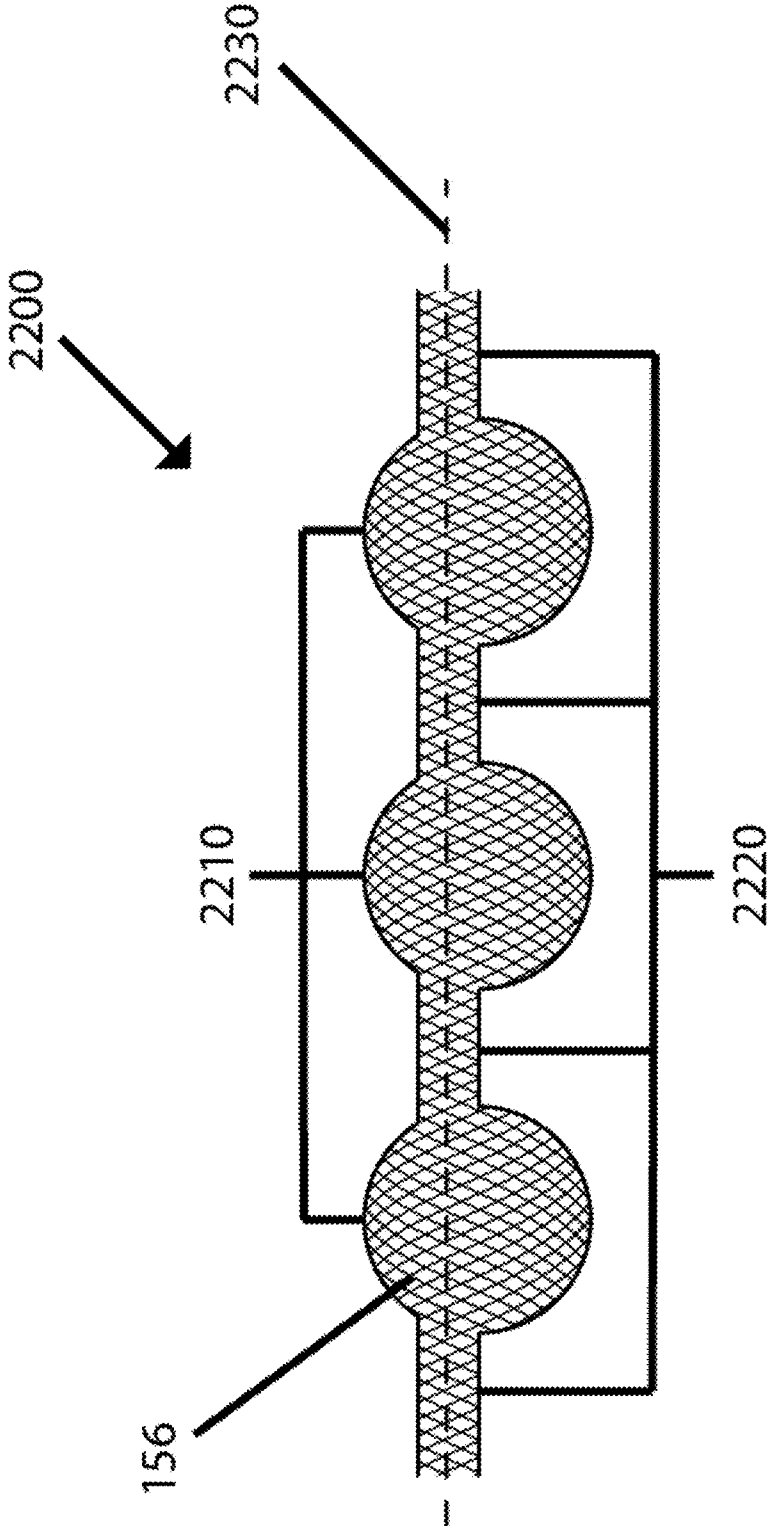


Fig. 4C

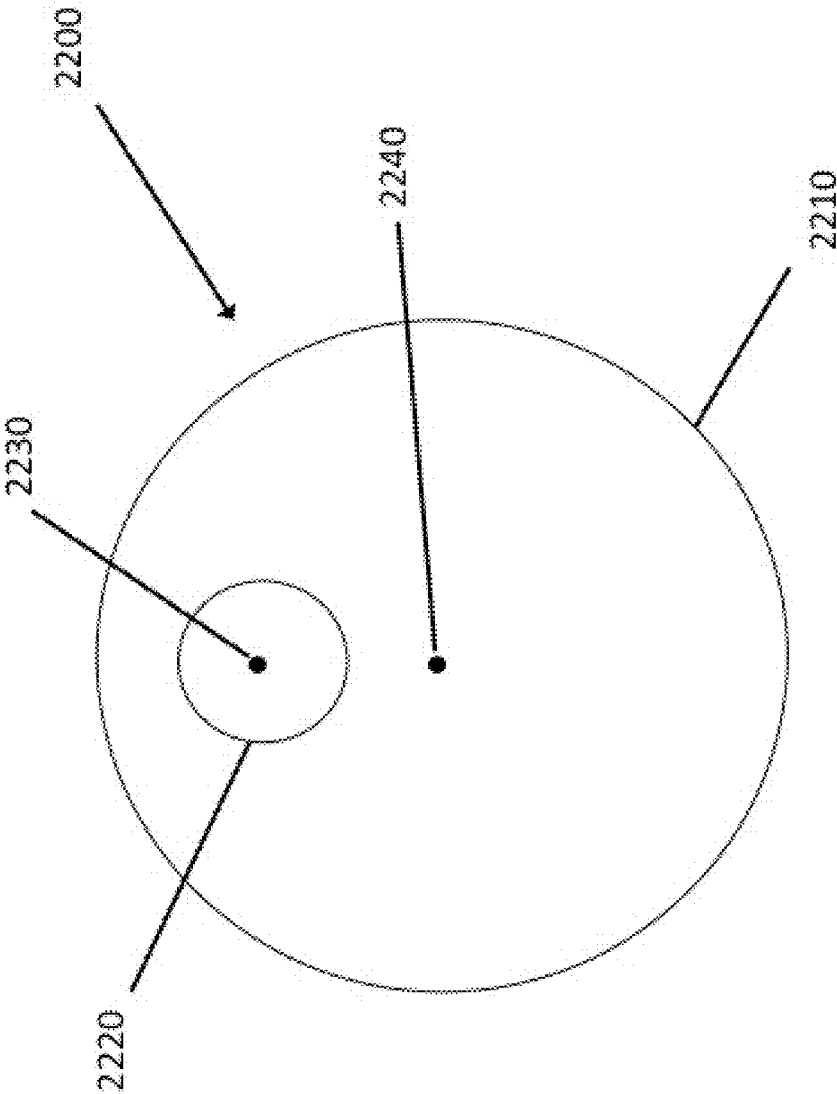


Fig. 4D



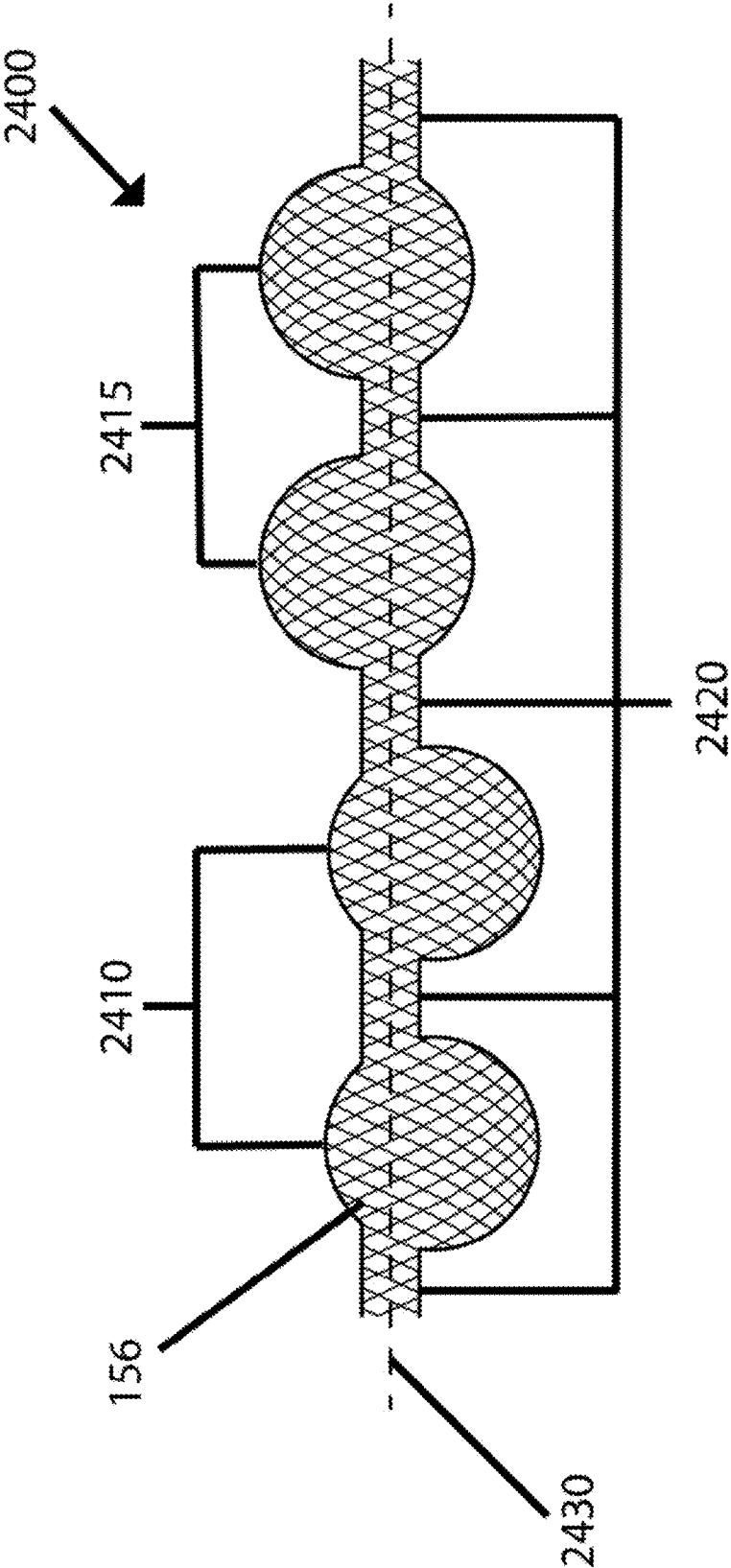


Fig. 4E

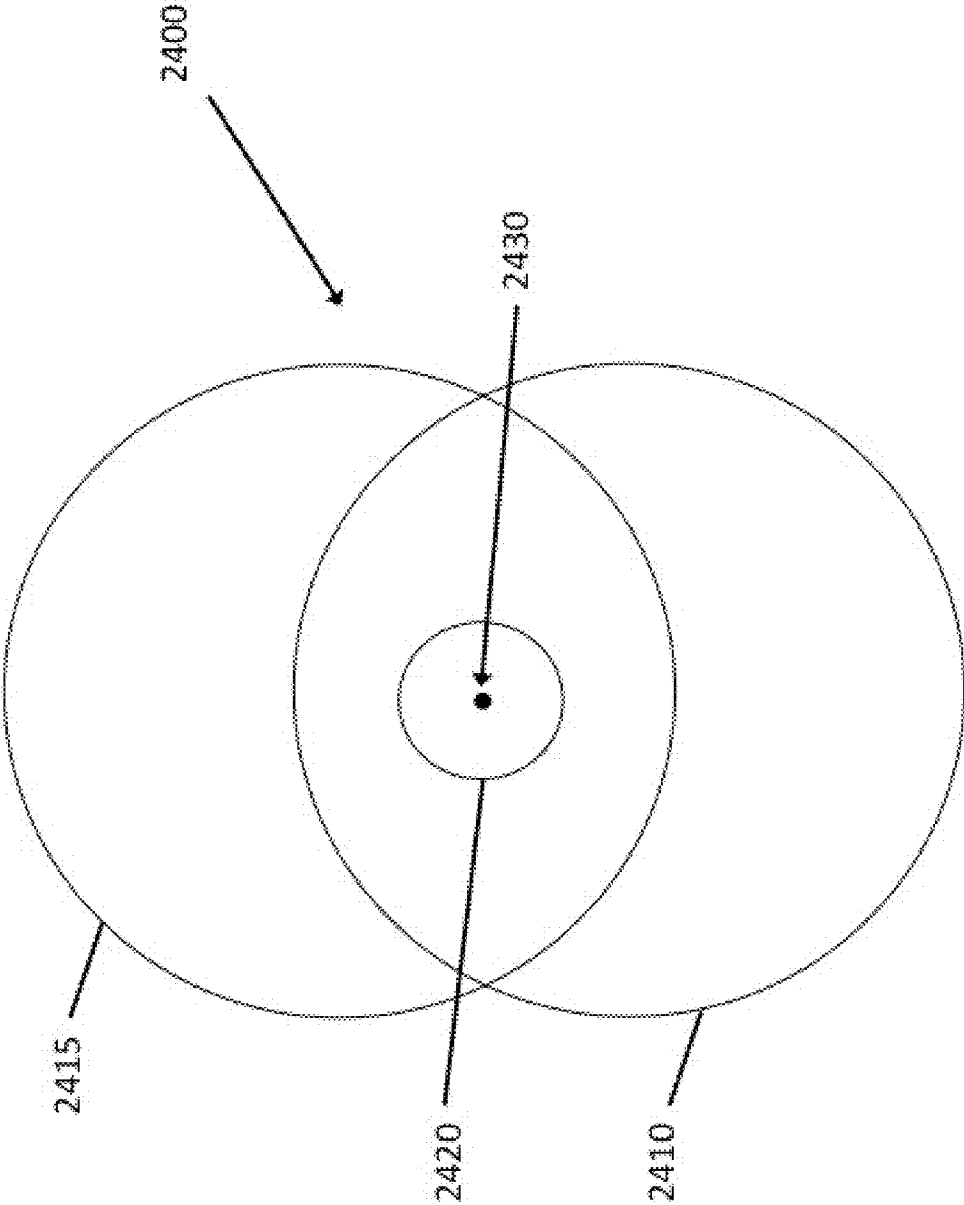


Fig. 4F

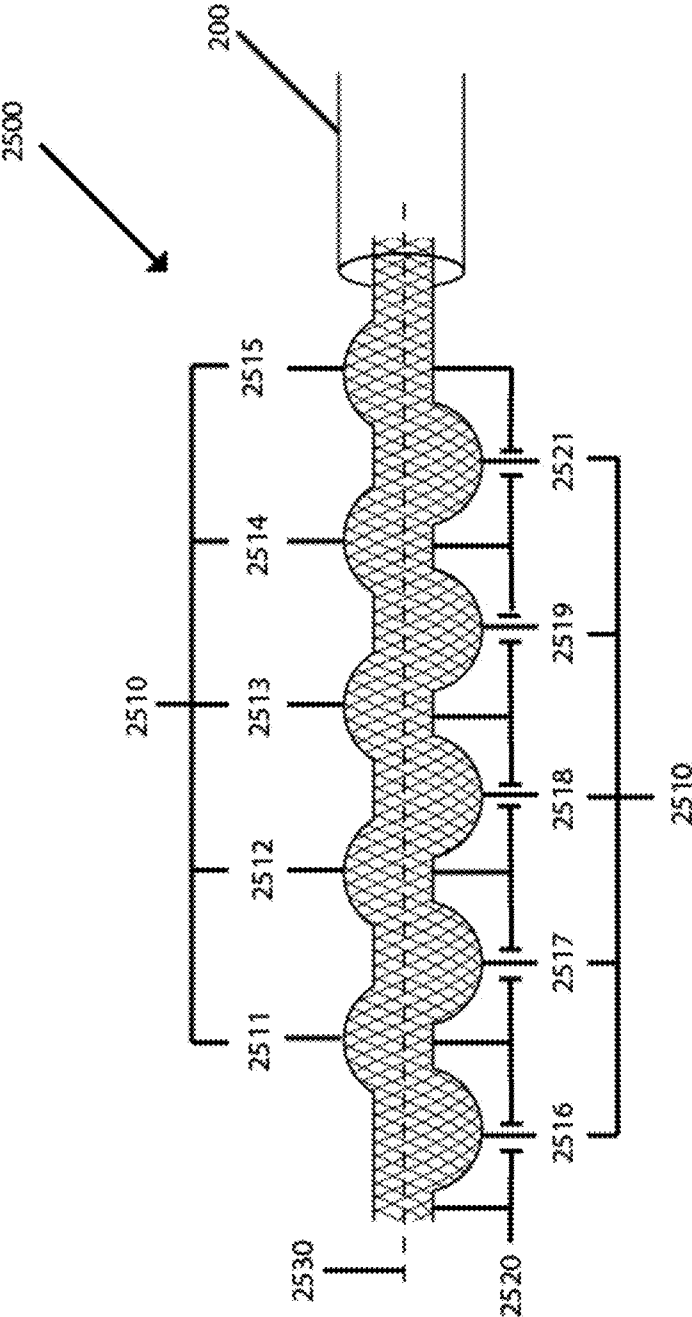


Fig. 4G

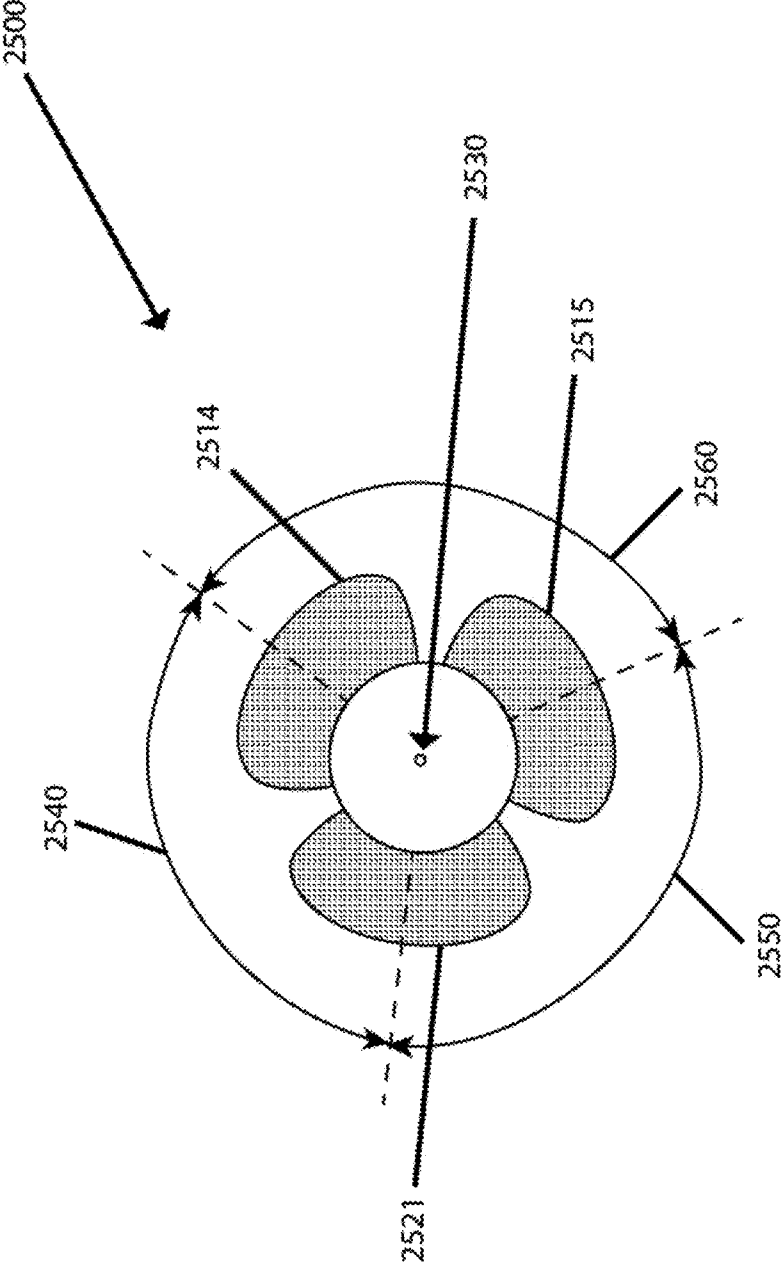


Fig. 4H

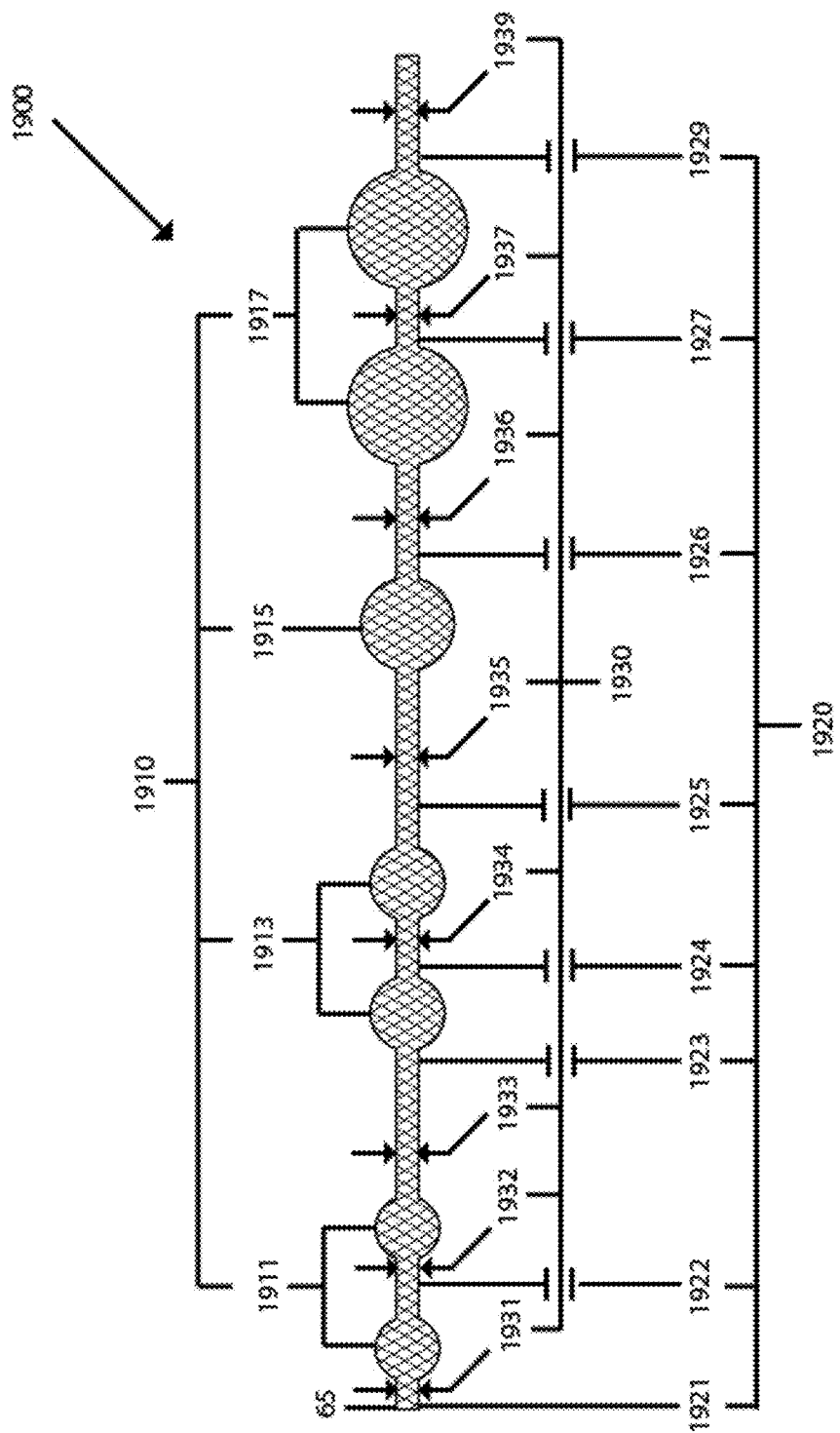


Fig. 4I

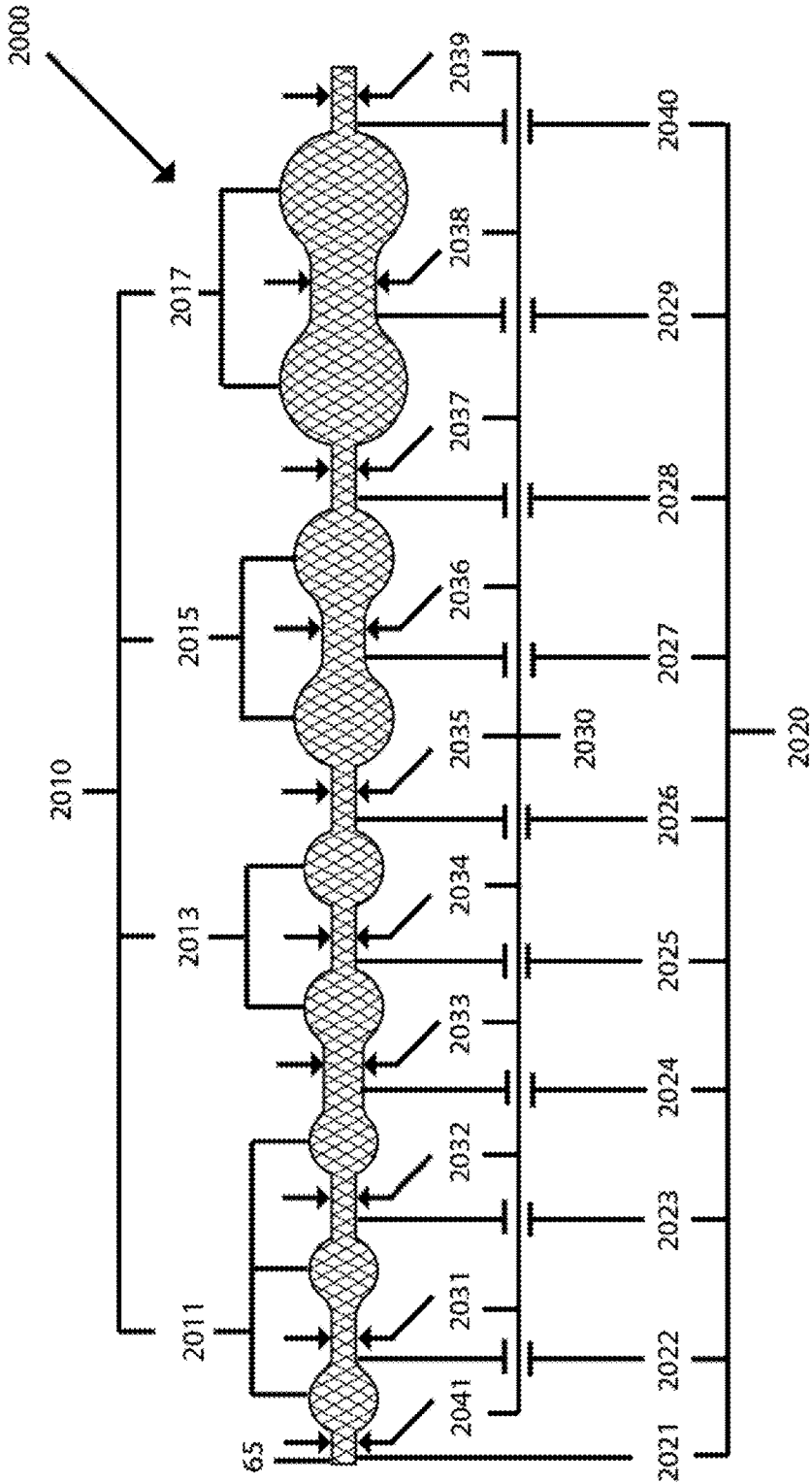


Fig. 4J

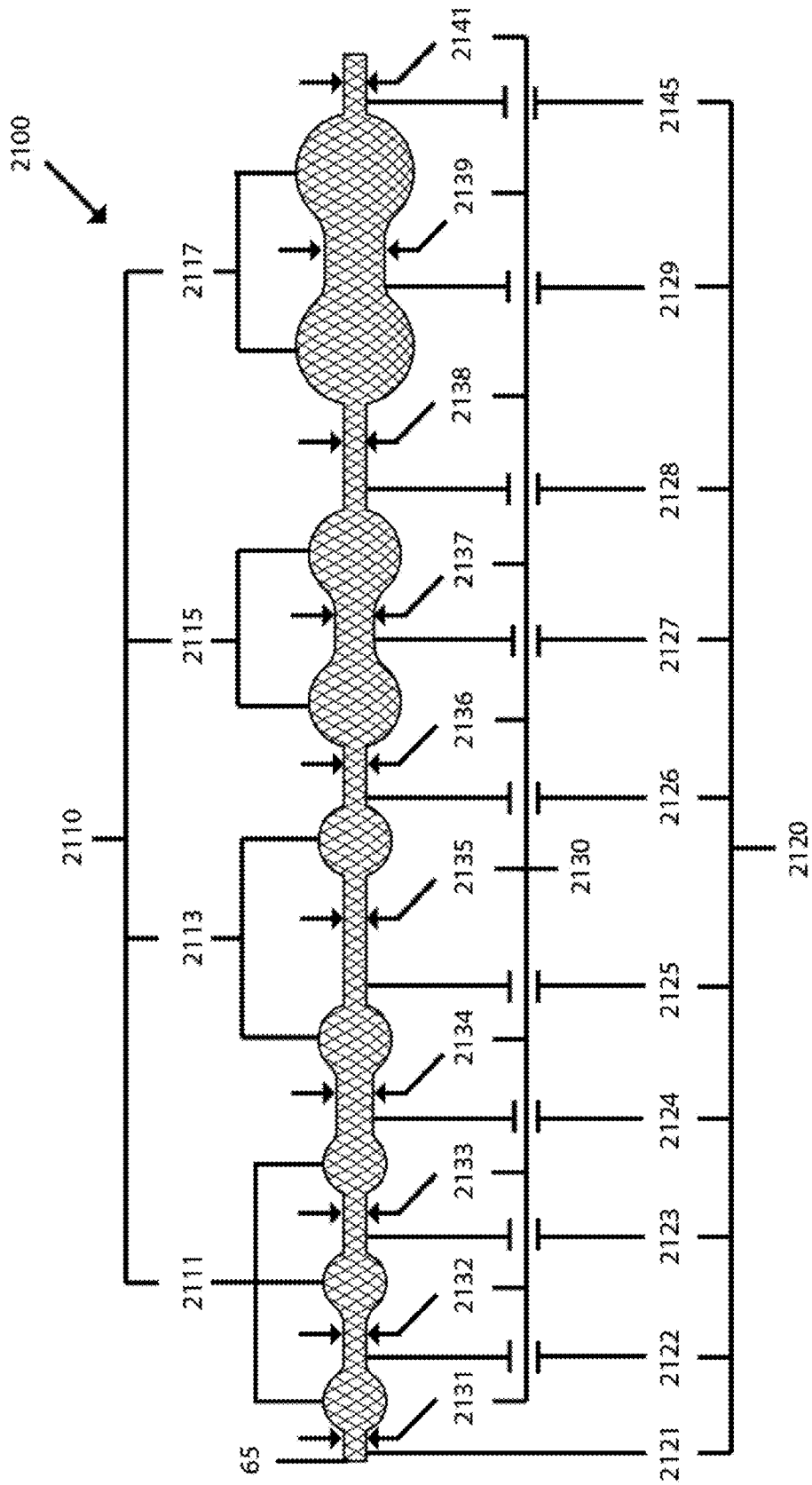


FIG. 4K

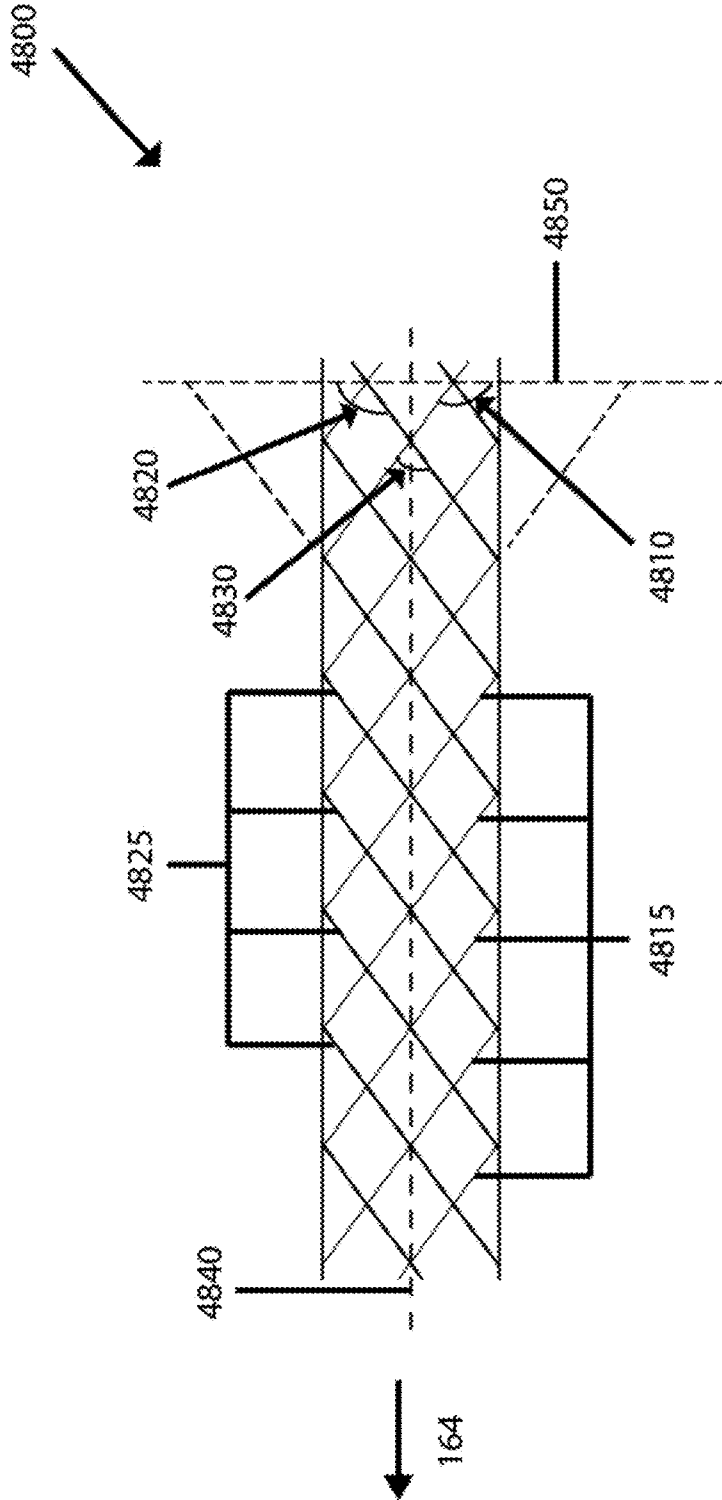


Fig. 4L



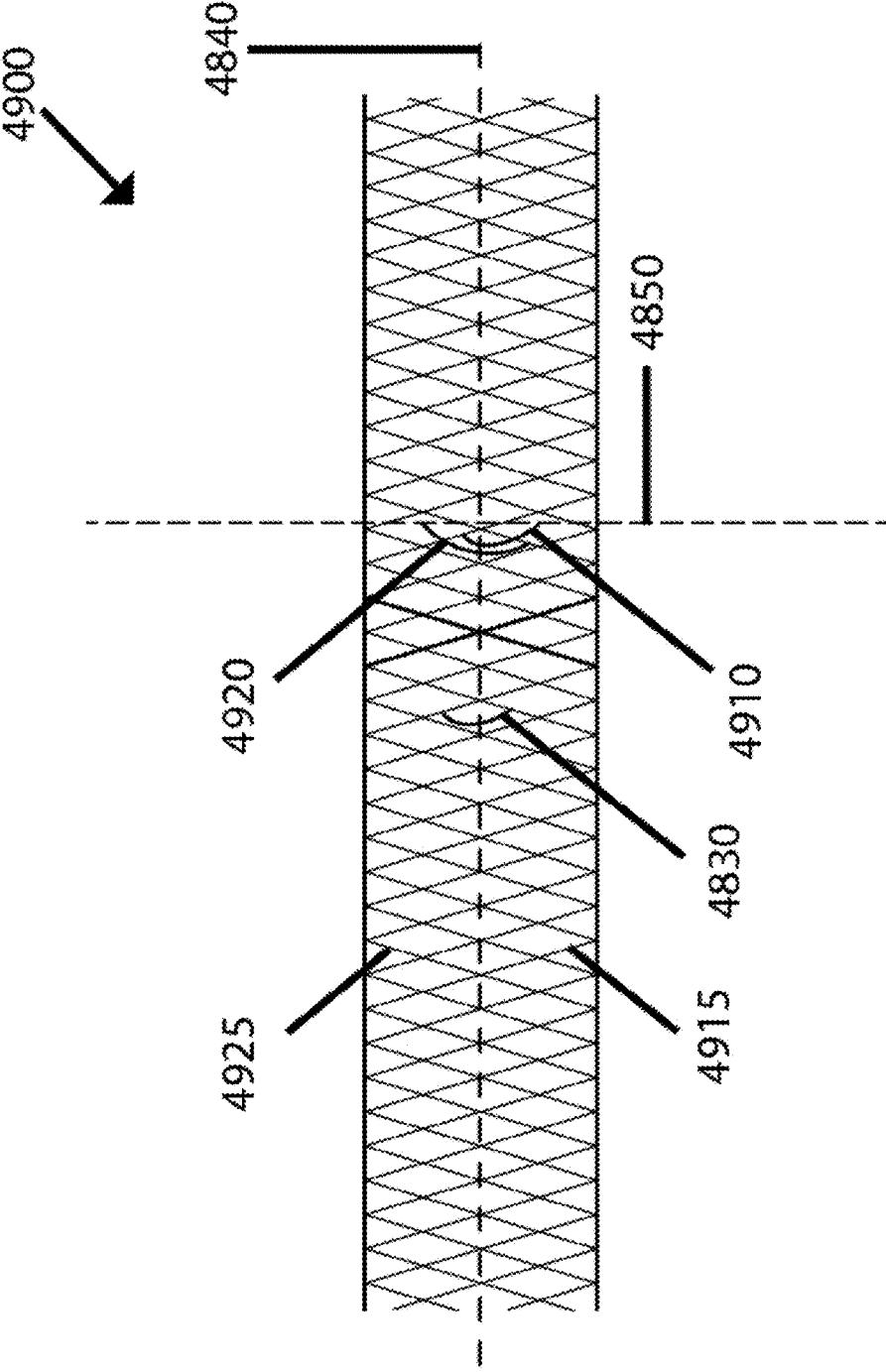


Fig. 4M

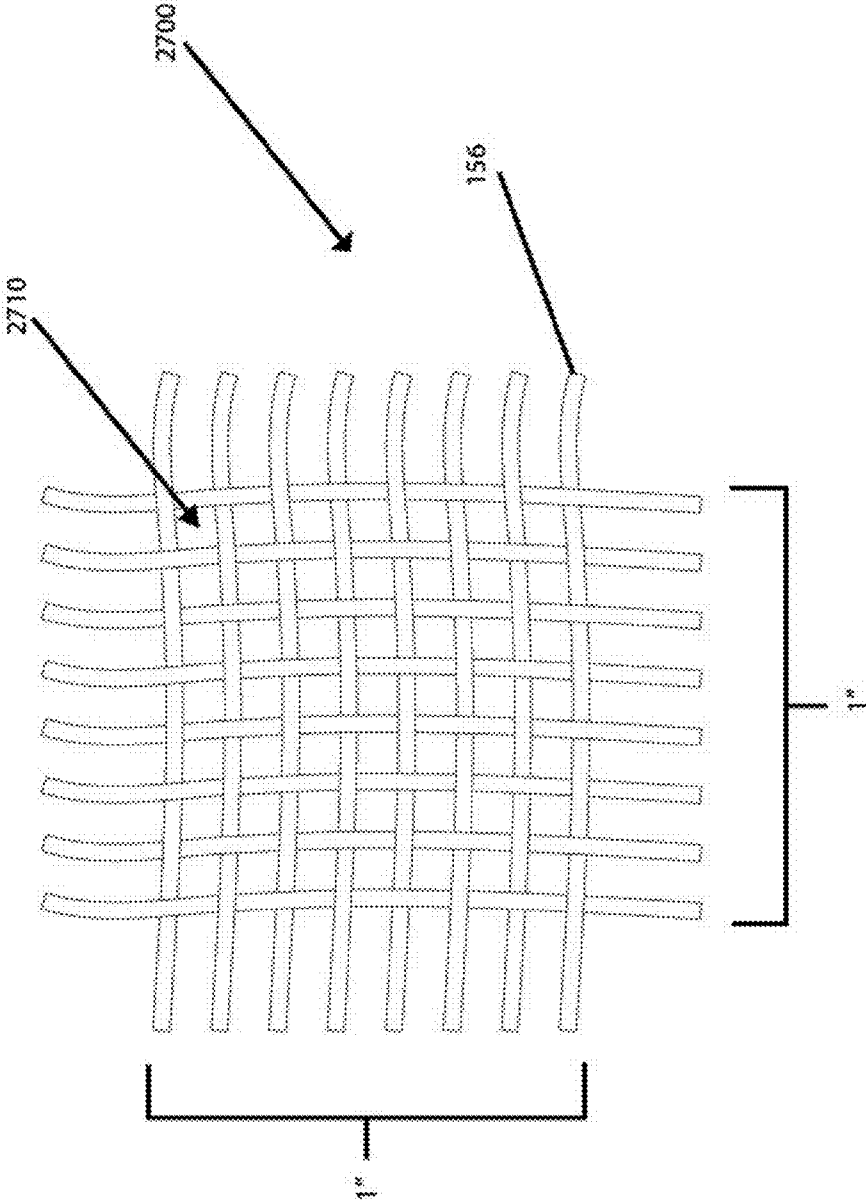


Fig. 4N

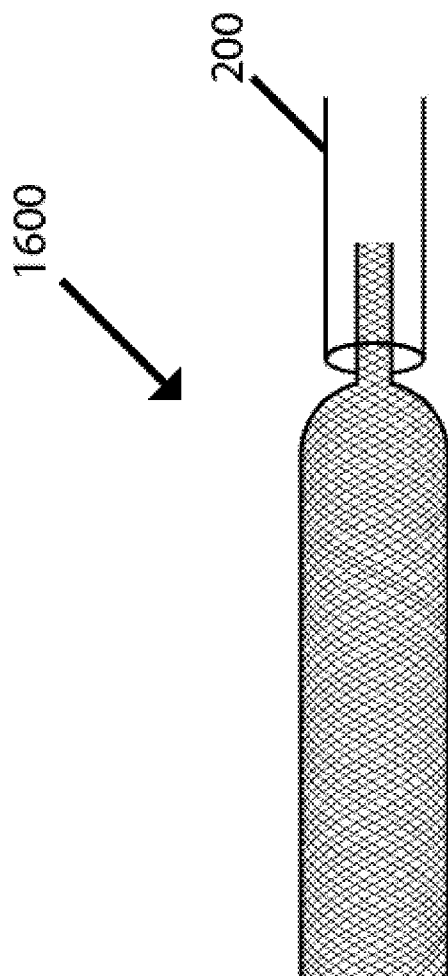


Fig. 5A

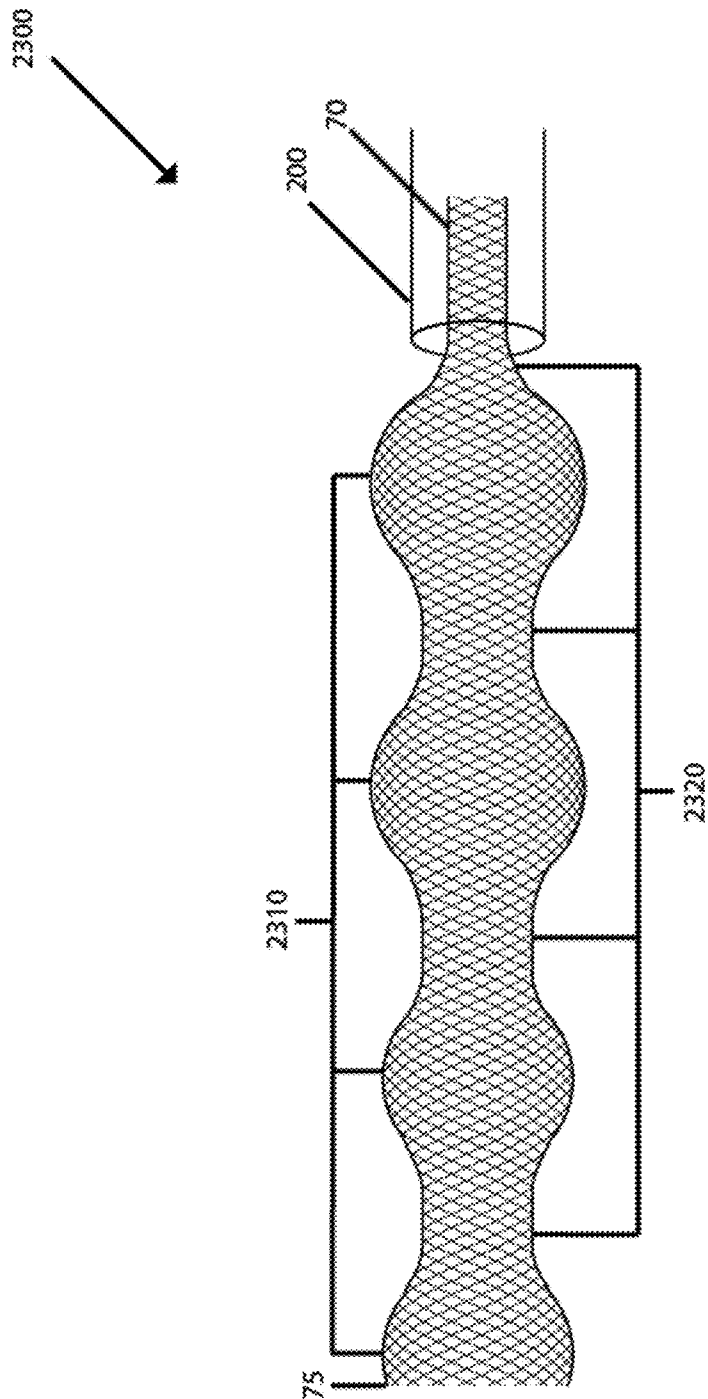


Fig. 5B

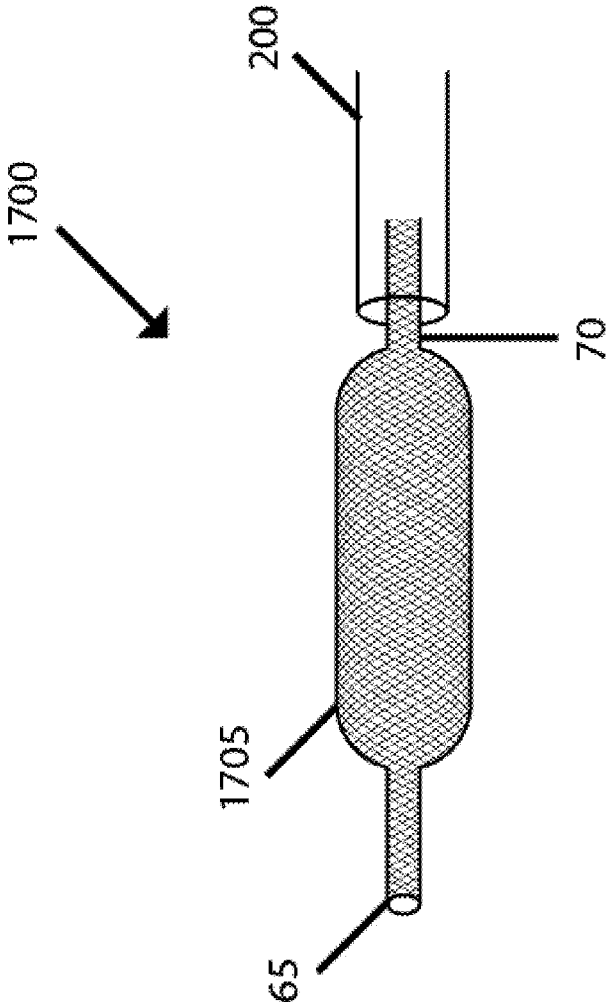


Fig. 5C

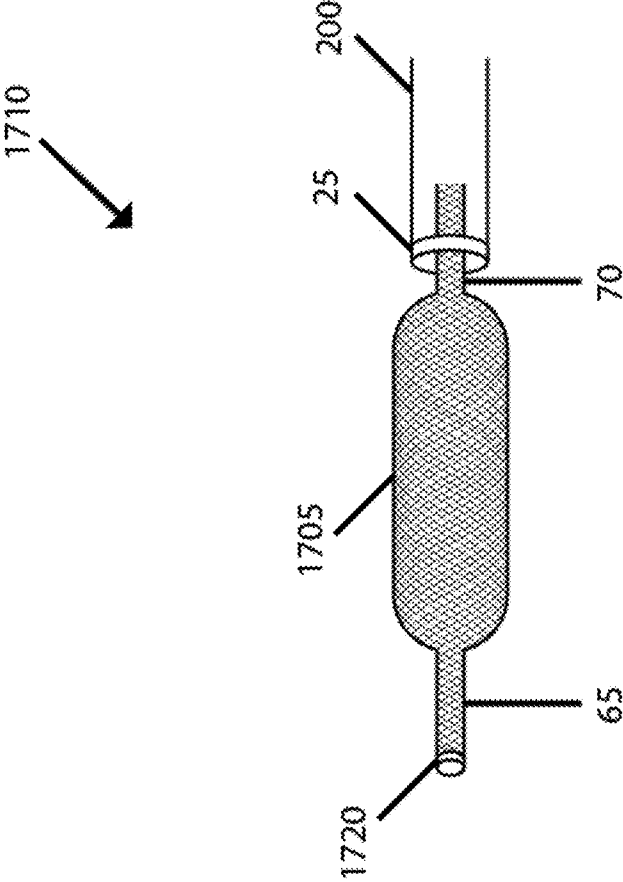


Fig. 5D

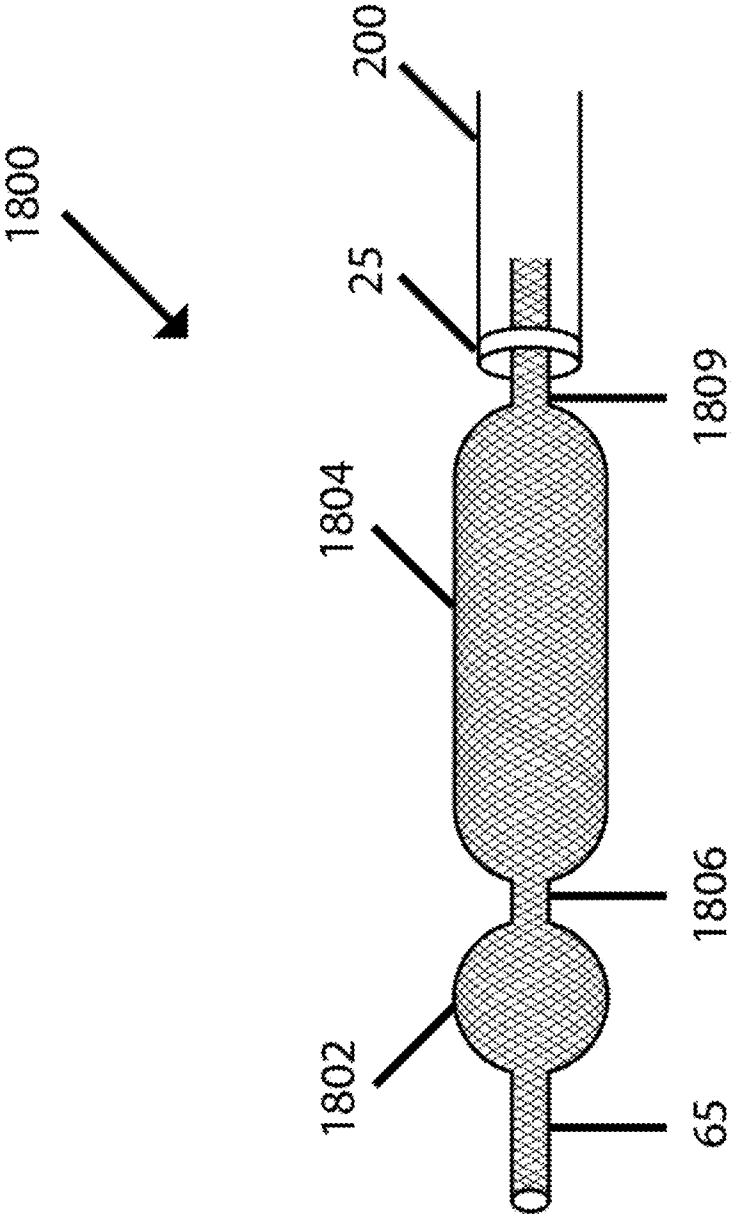


Fig. 5E

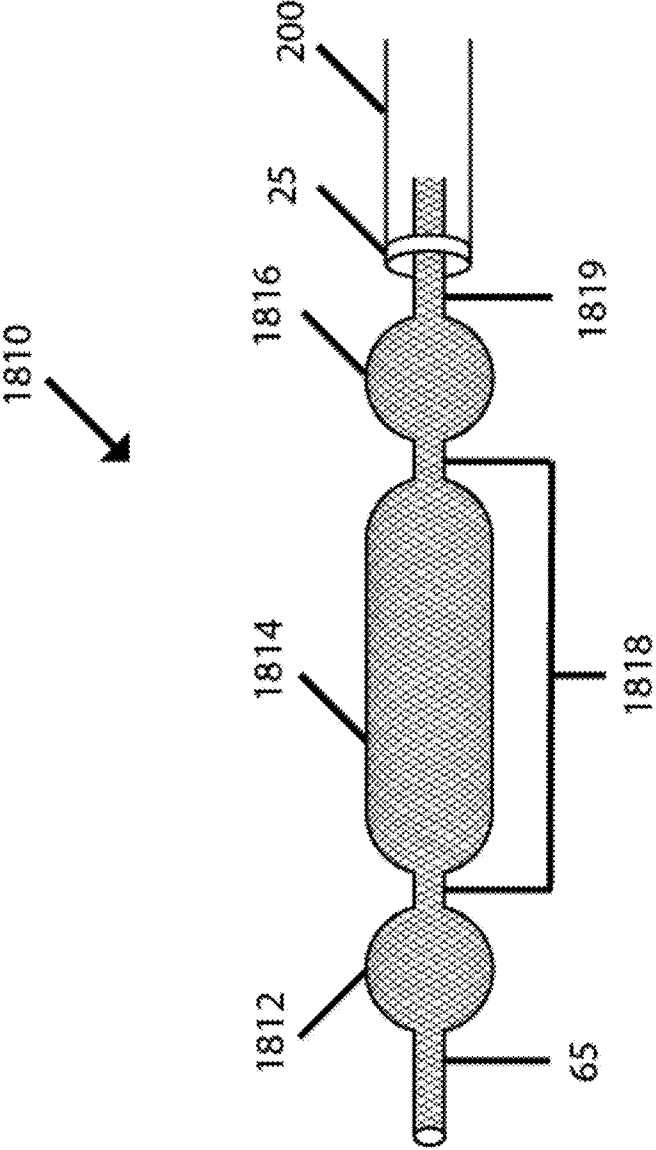


Fig. 5F



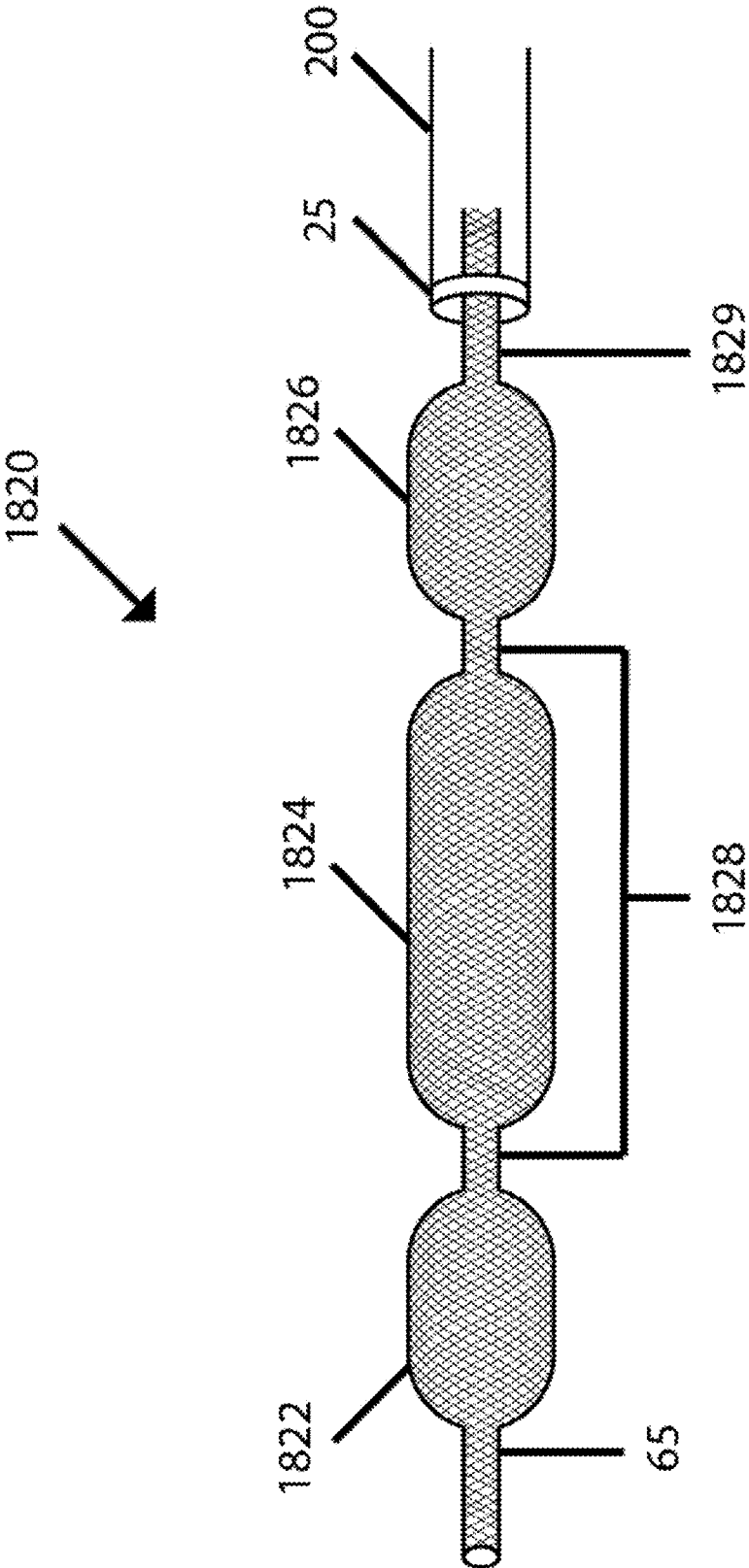


Fig. 5G

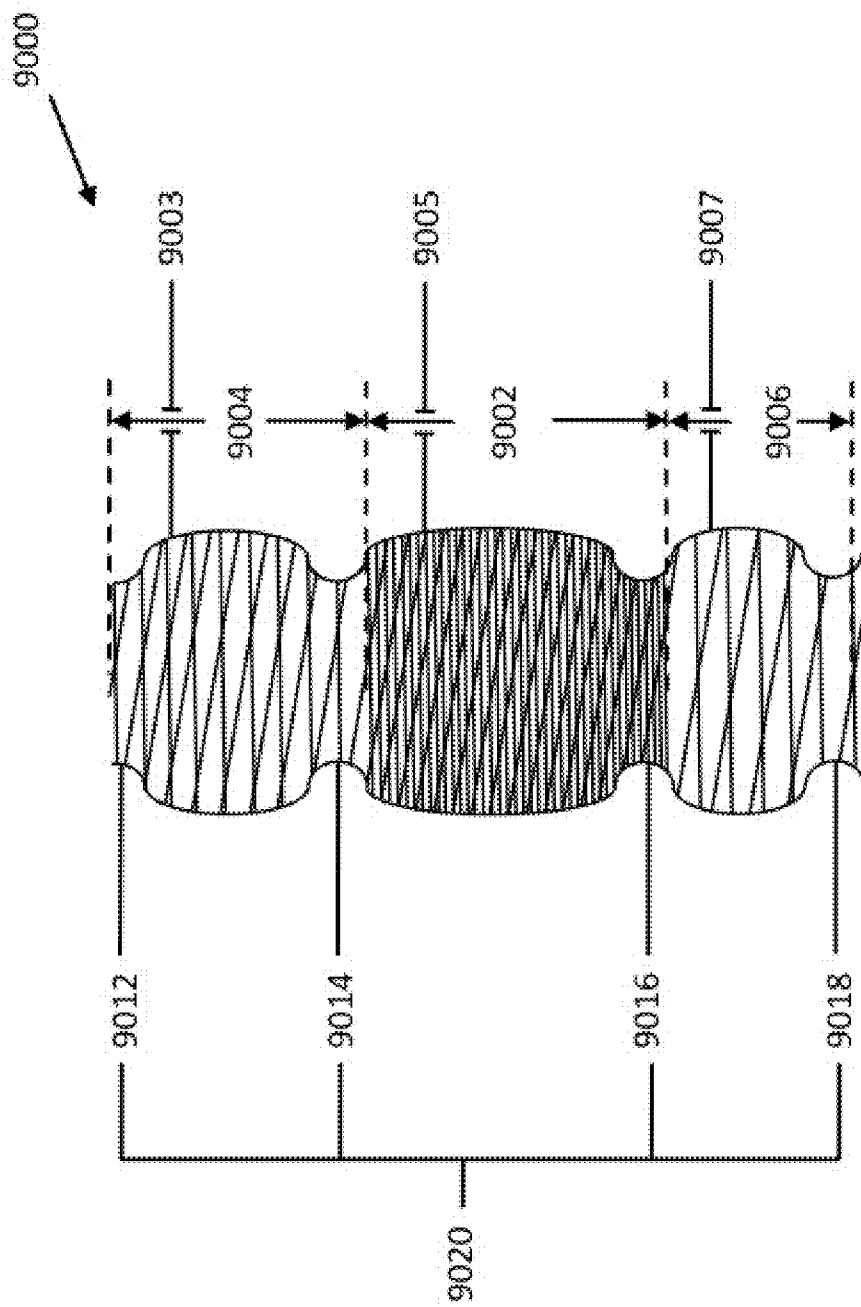


Fig. 6A

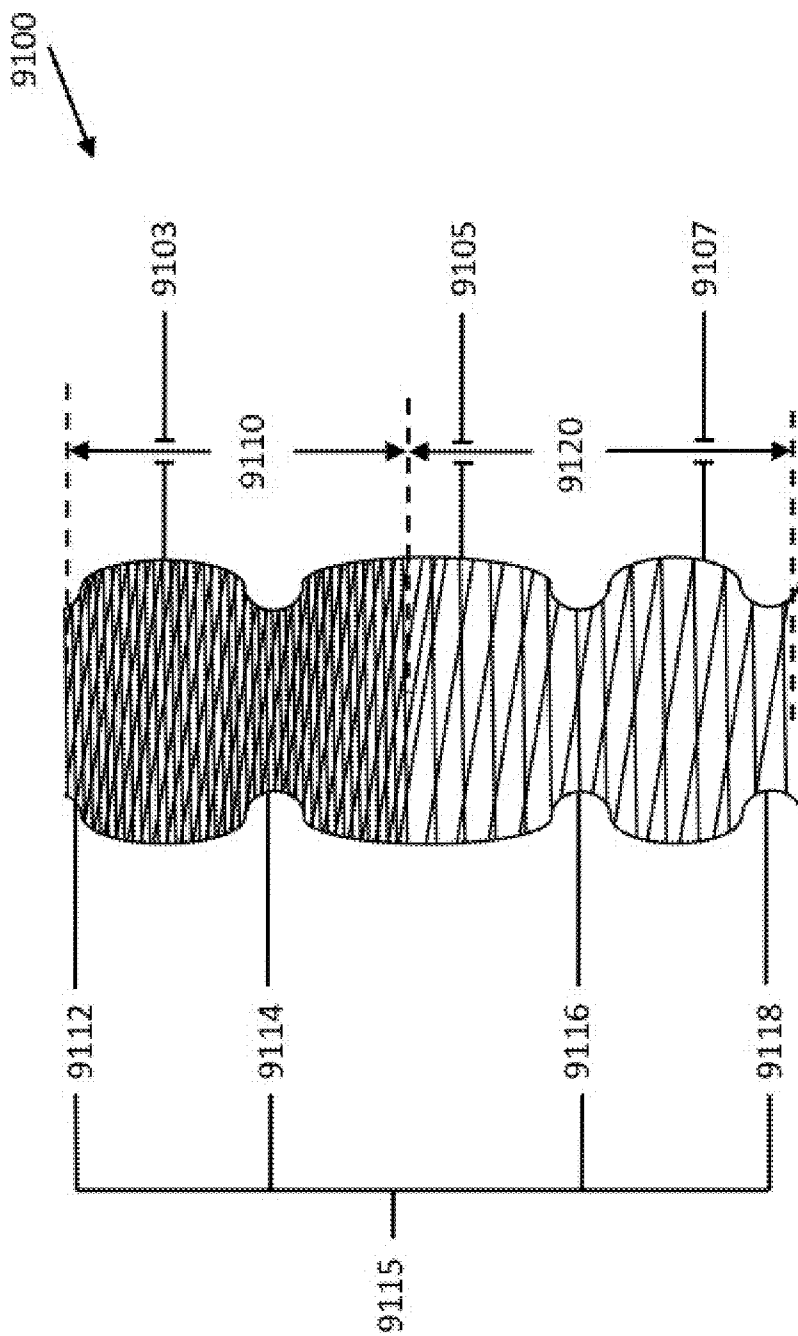


Fig. 6B

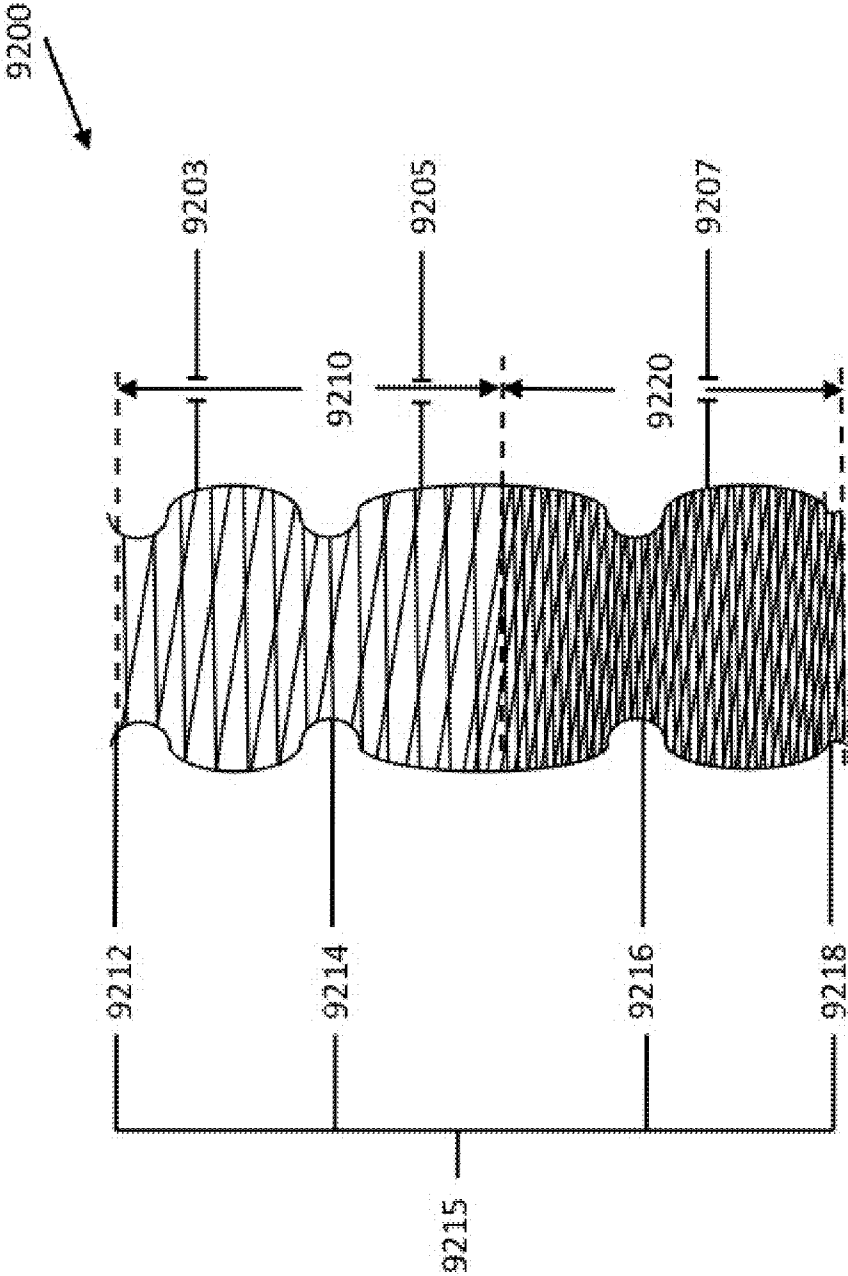


Fig. 6C

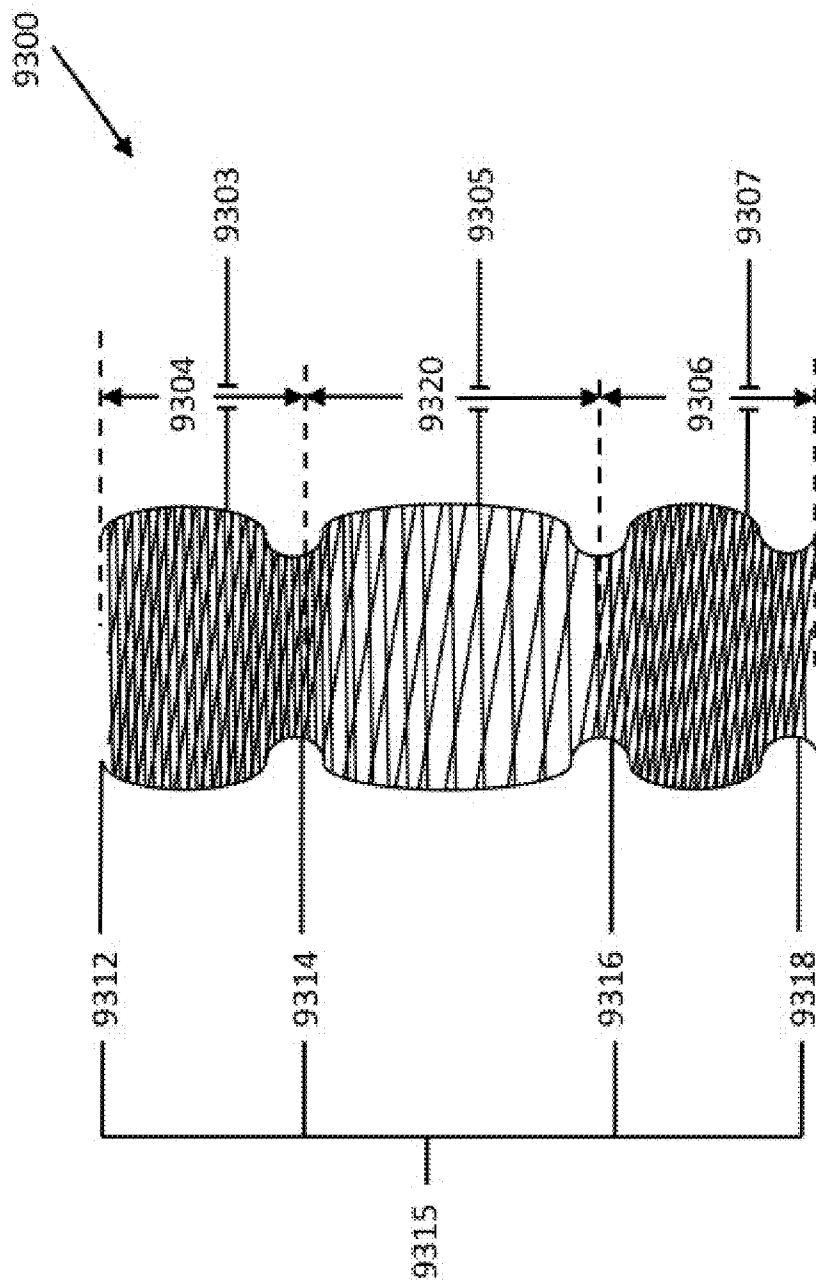


Fig. 6D

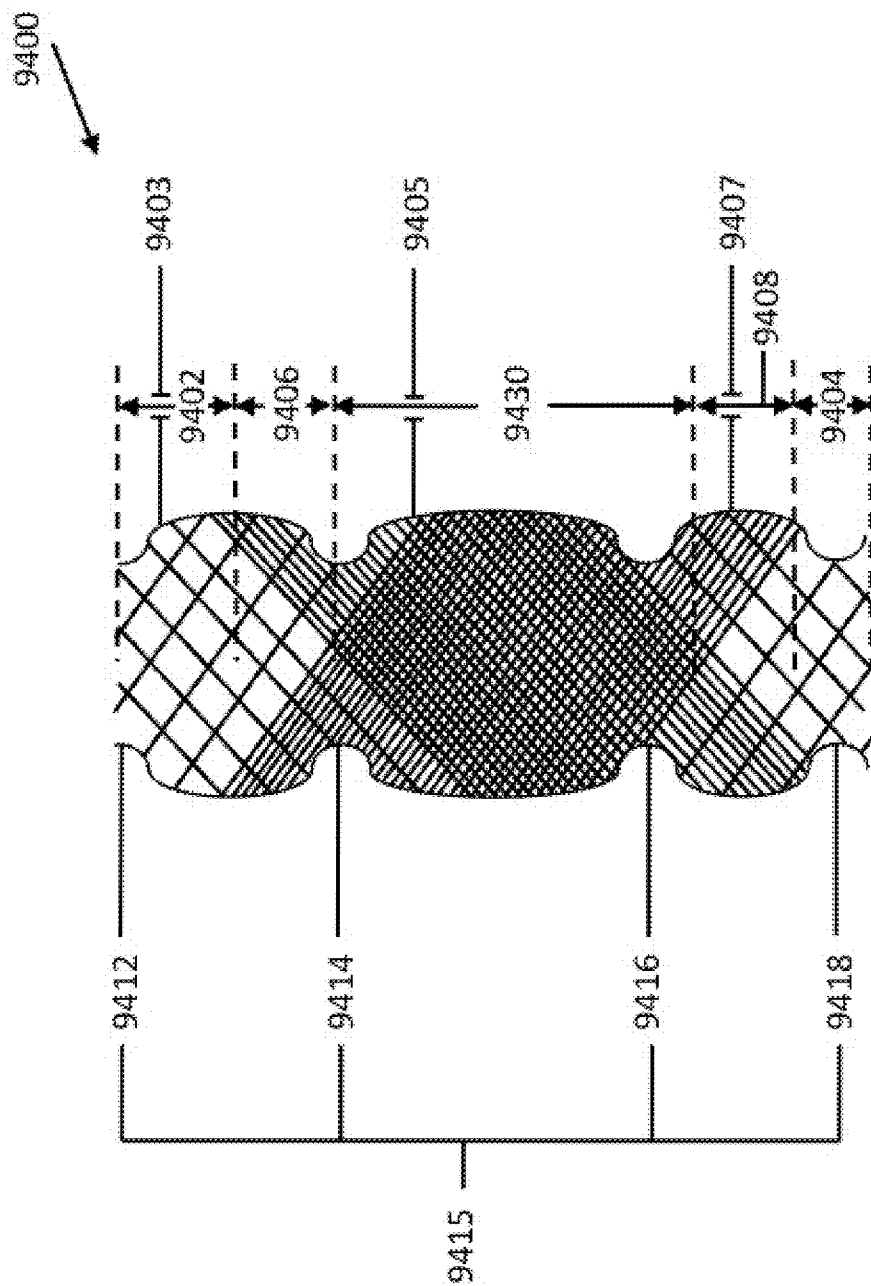


Fig. 6E

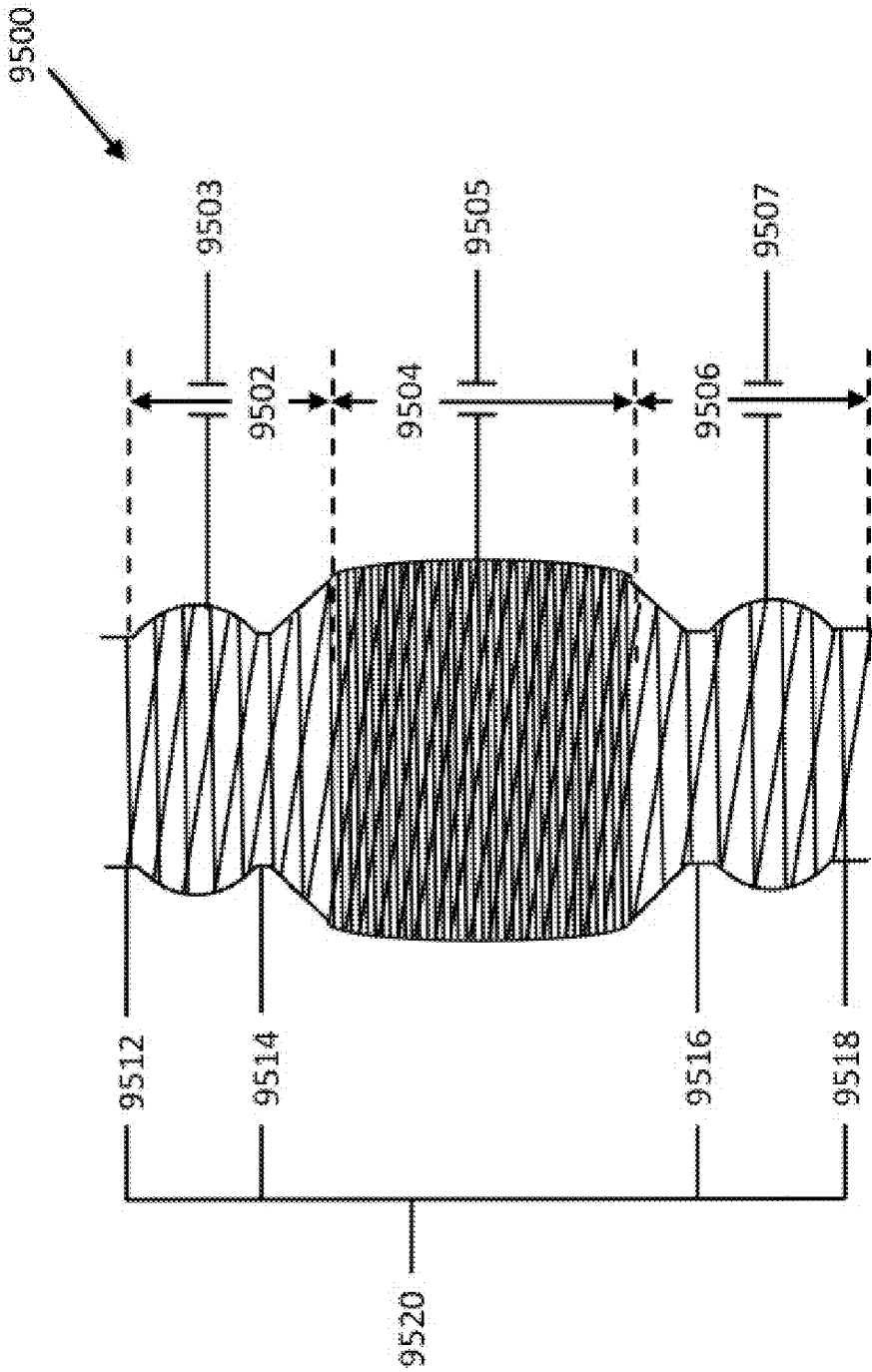


Fig. 6F

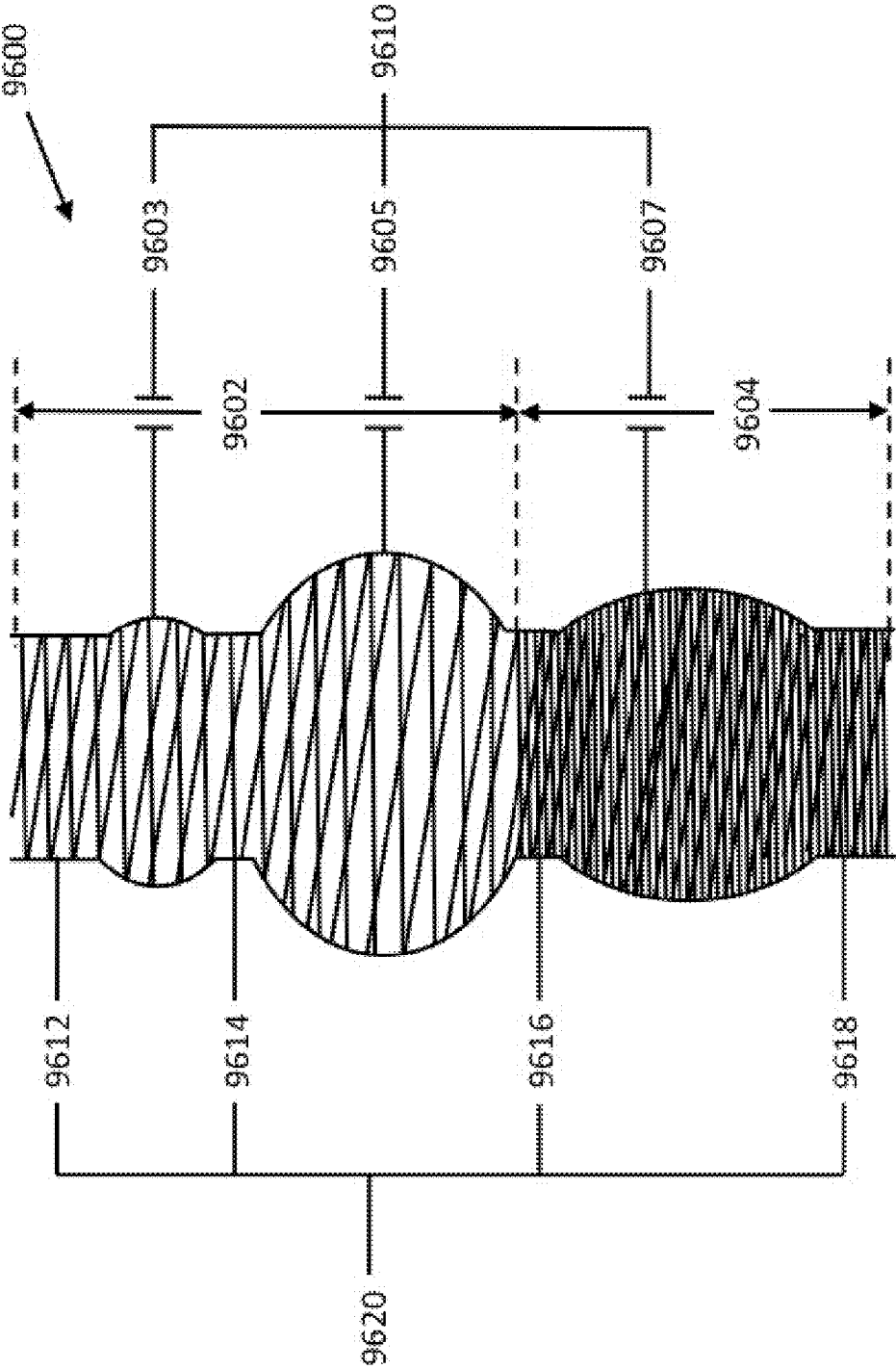


Fig. 6G



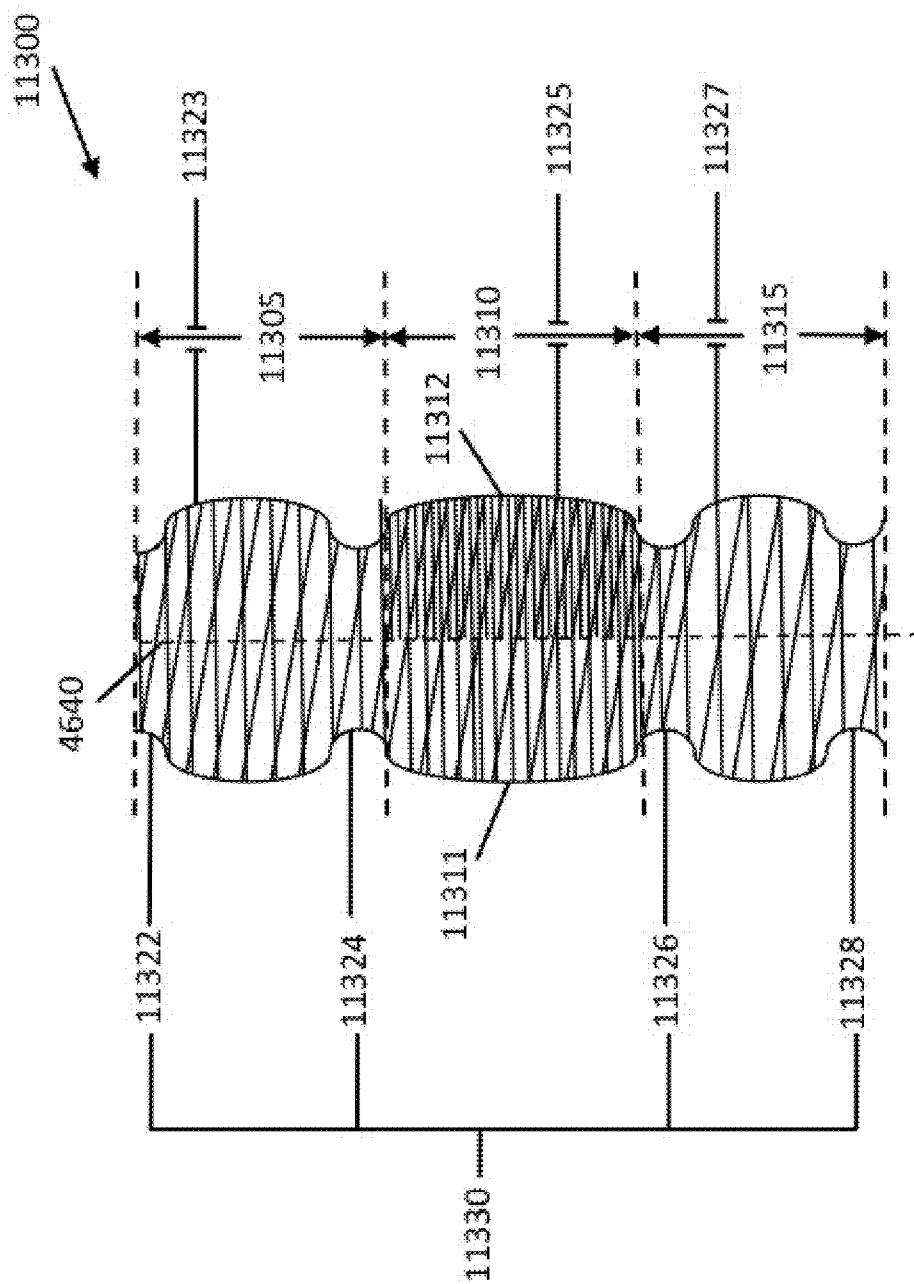


Fig. 6H

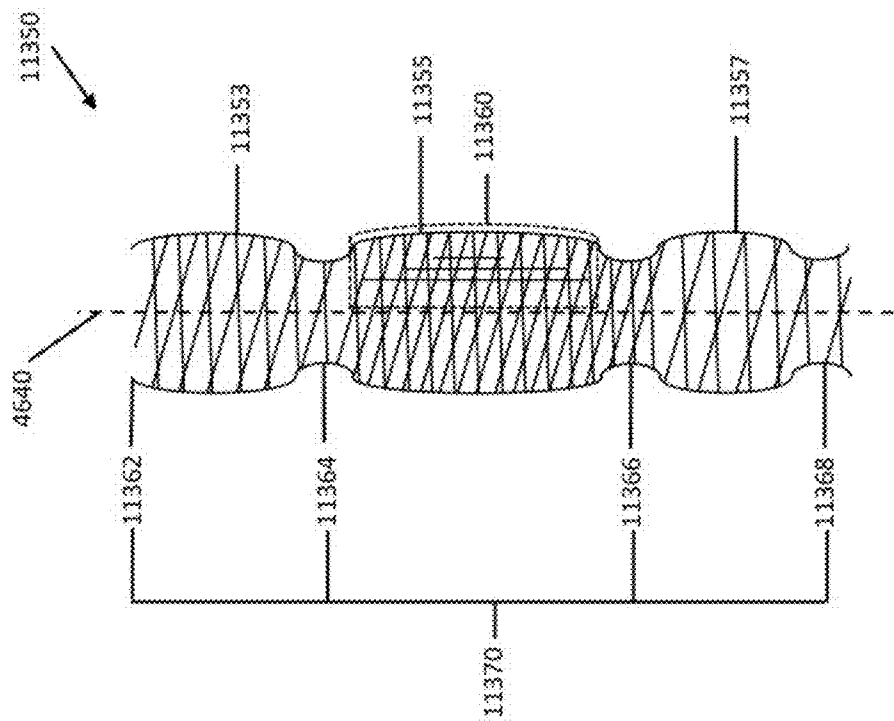
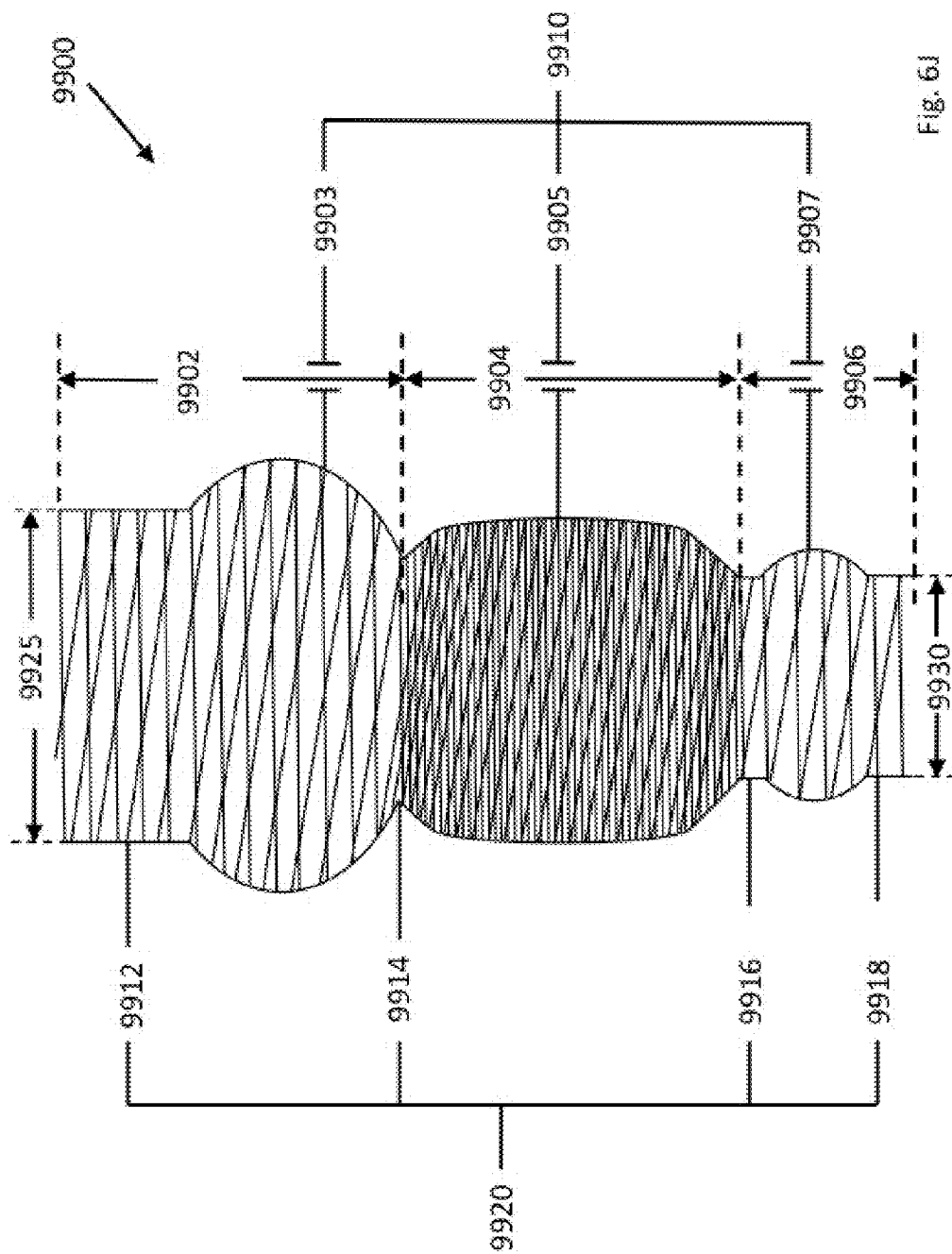


Fig. 6I



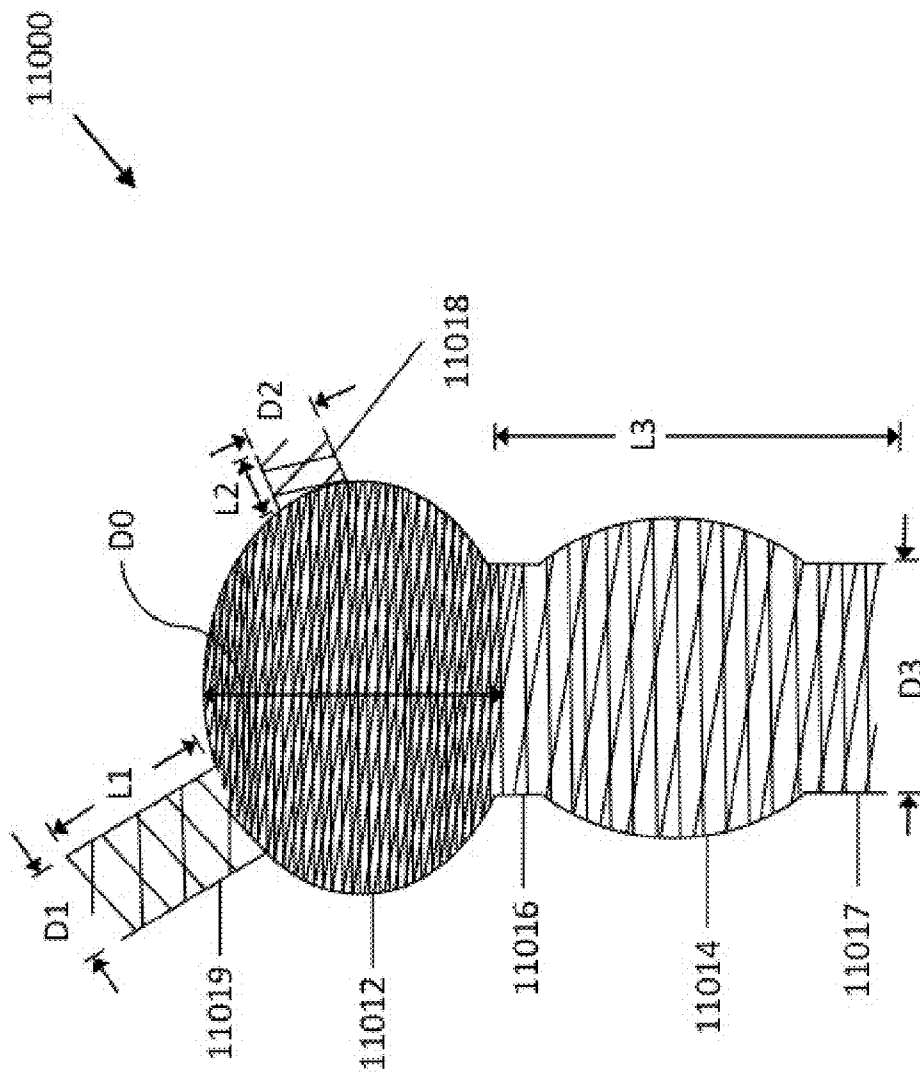


Fig. 7A

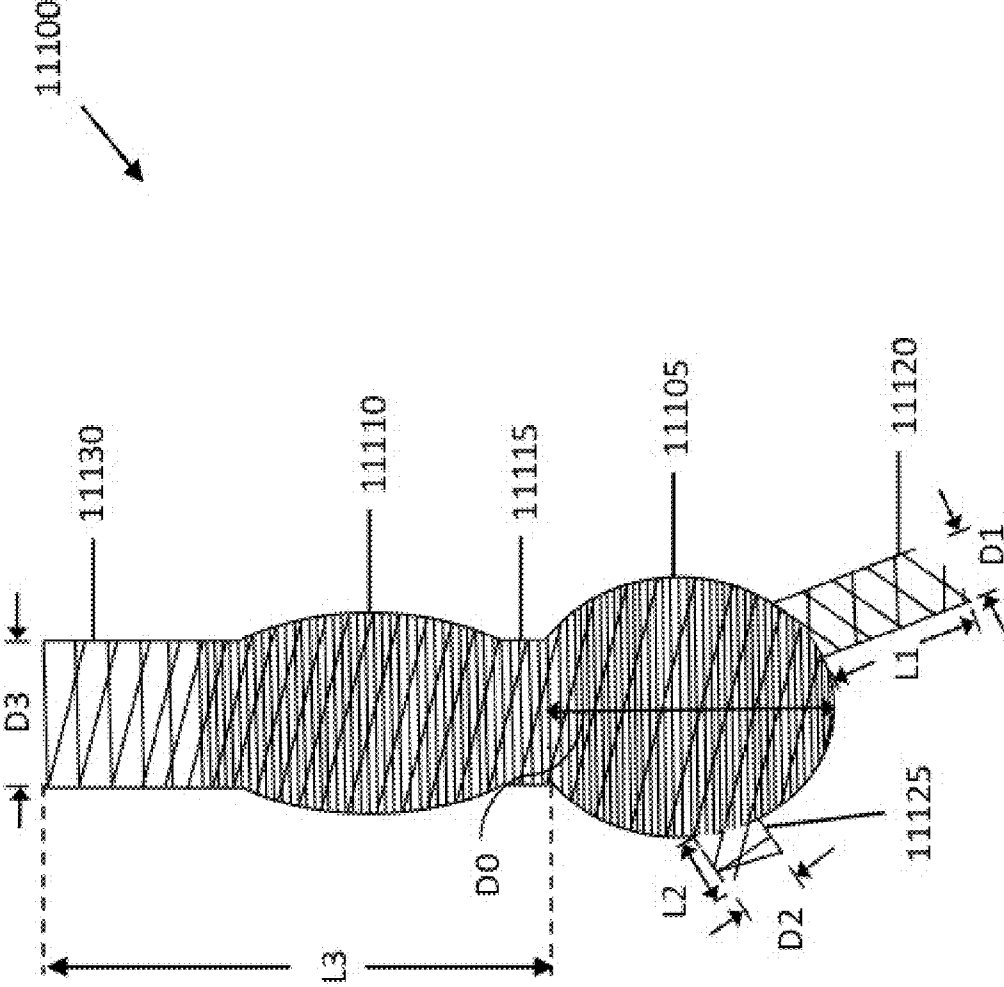


Fig. 7B

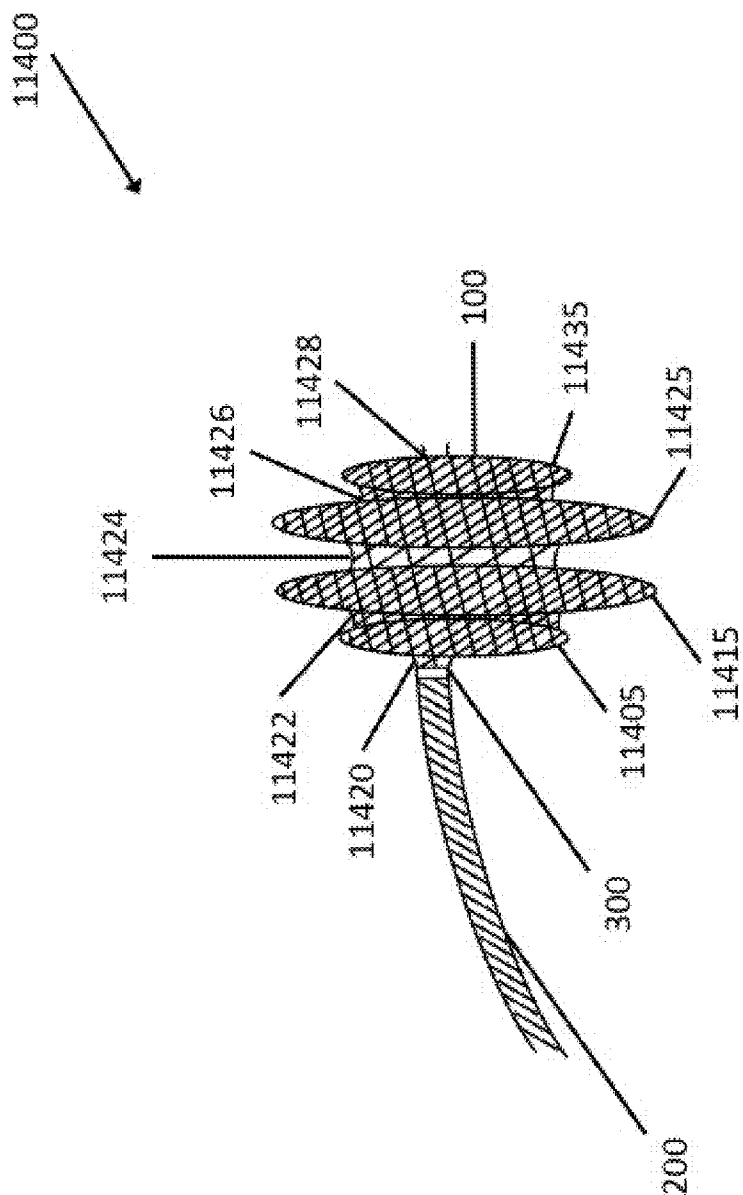


Fig. 7C

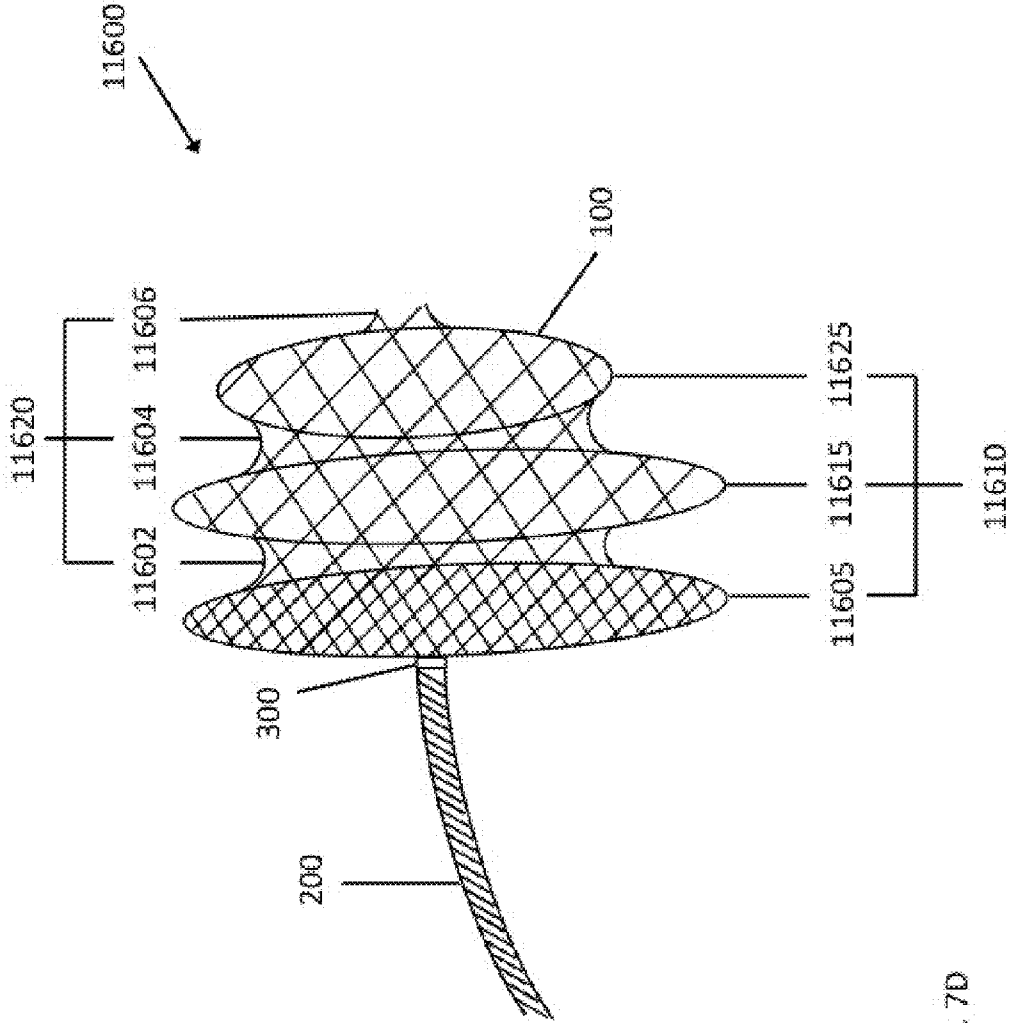


Fig. 7D

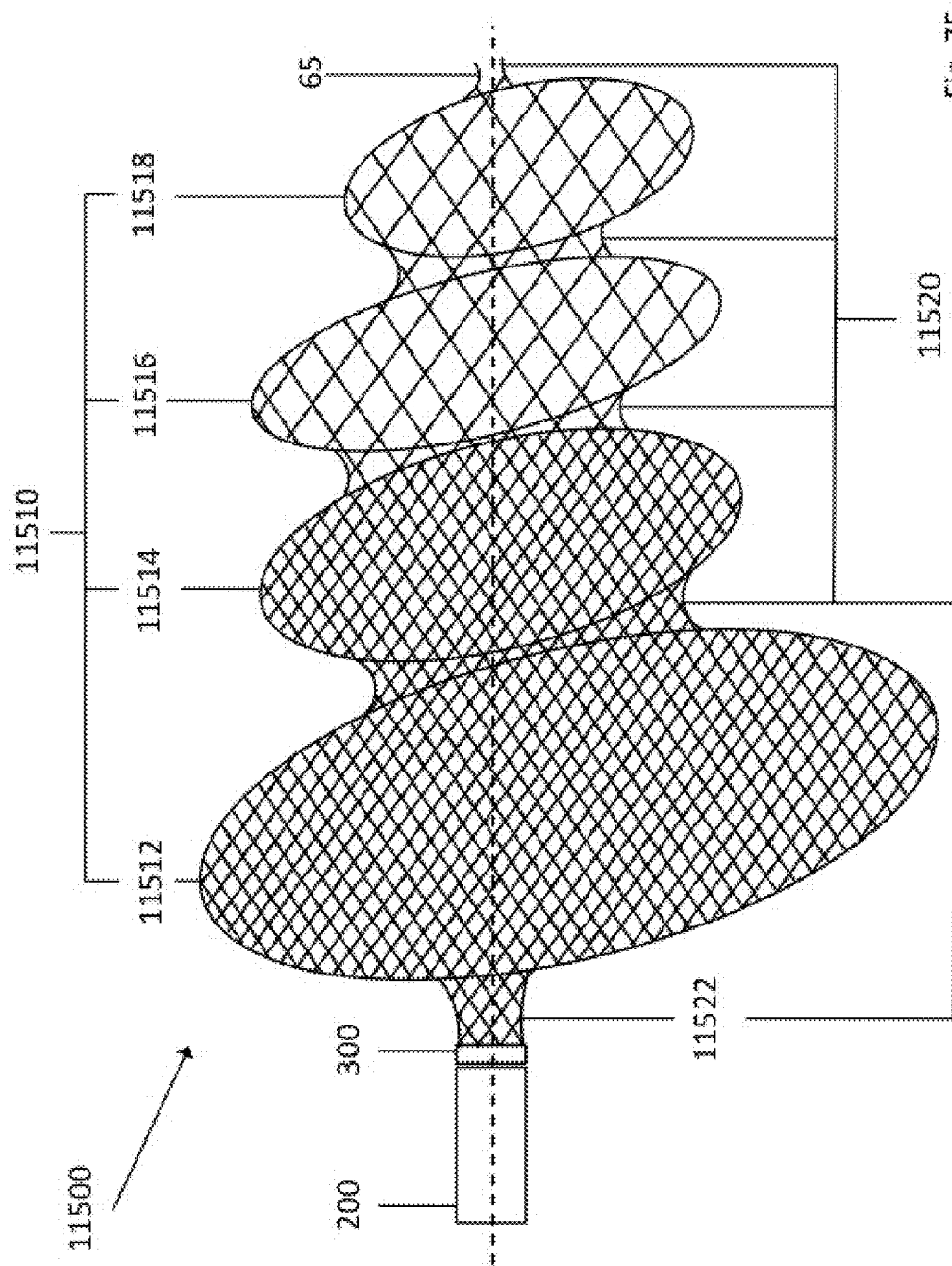


Fig. 7E



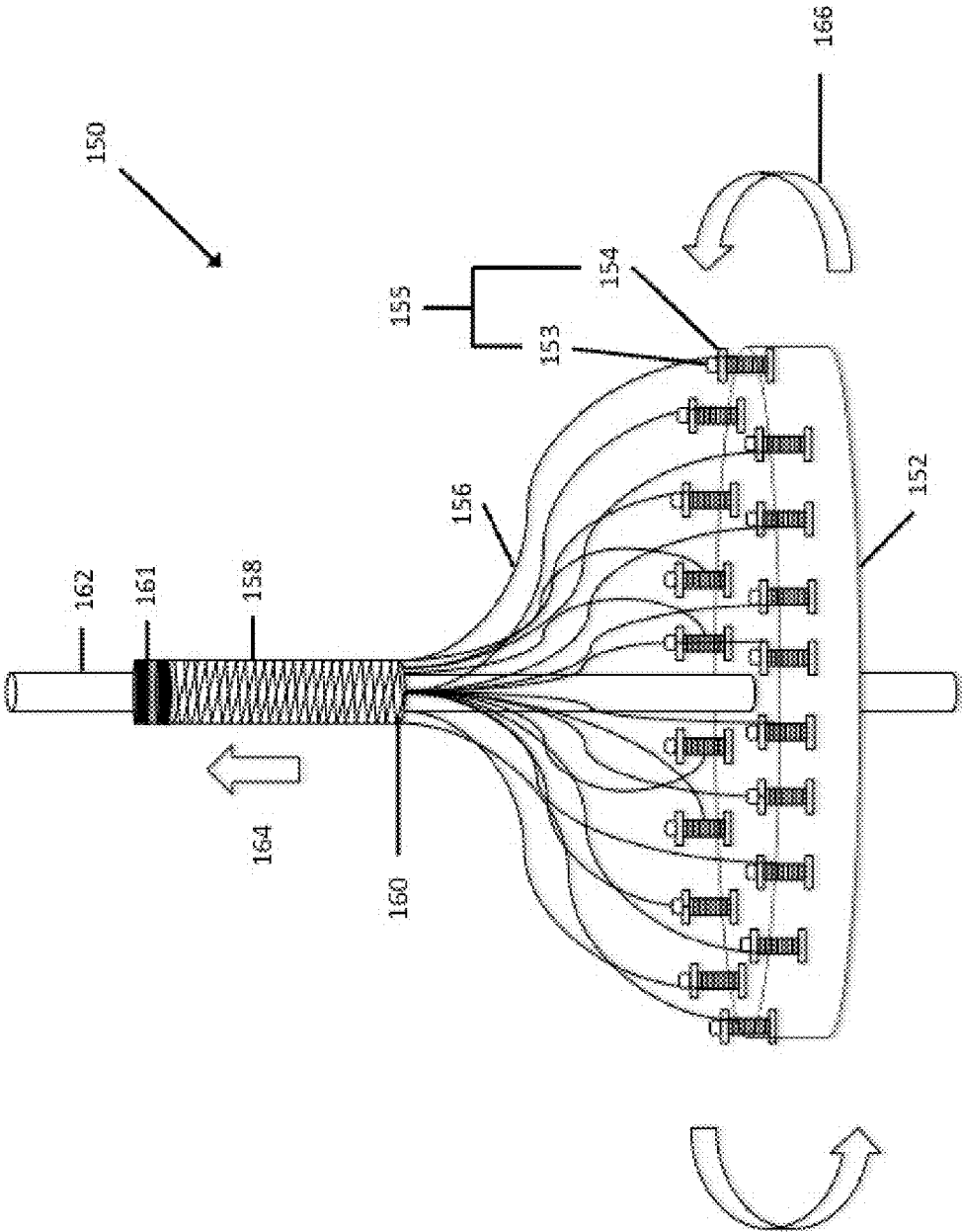


Fig. 8A

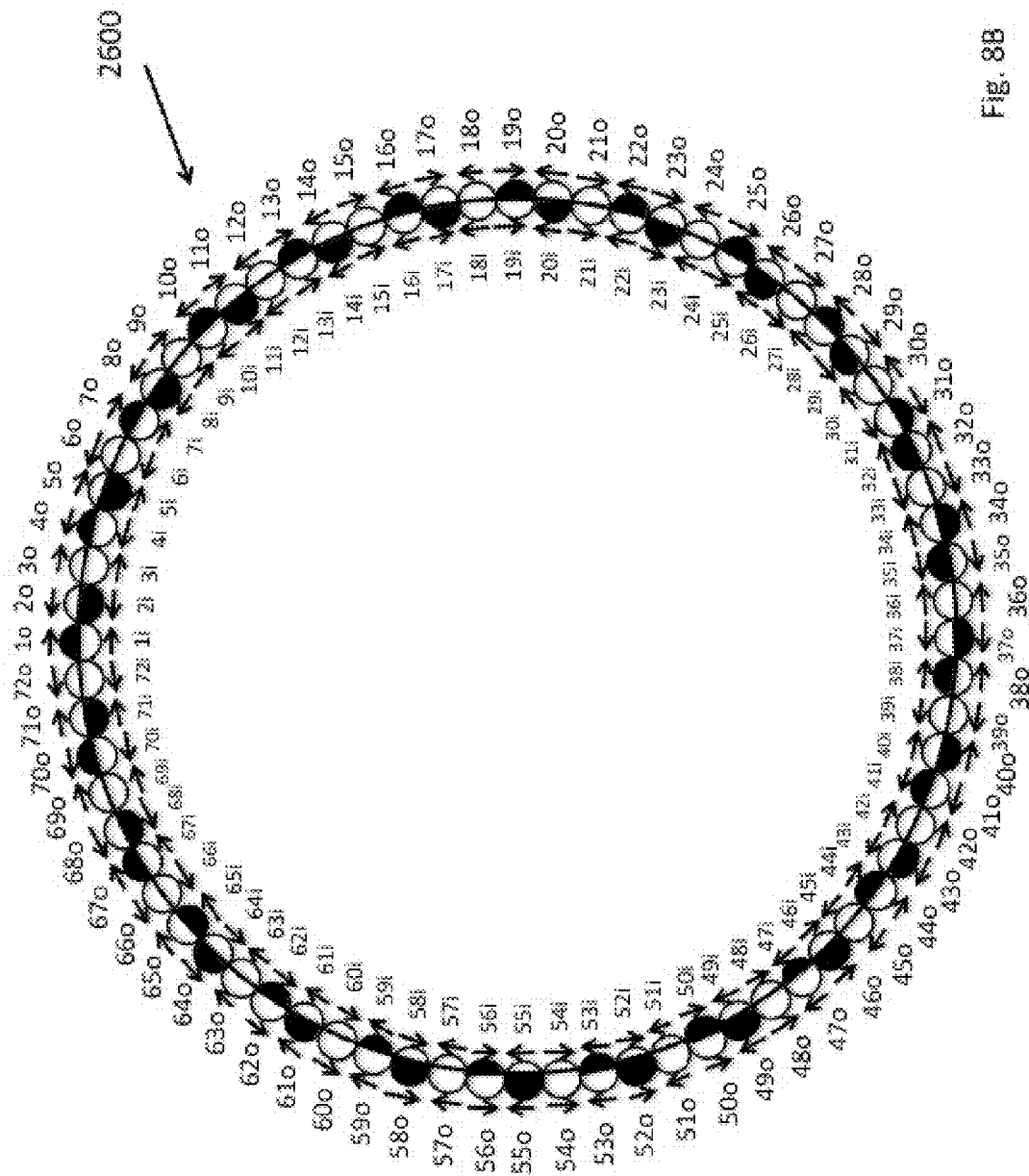


Fig. 8B

2600

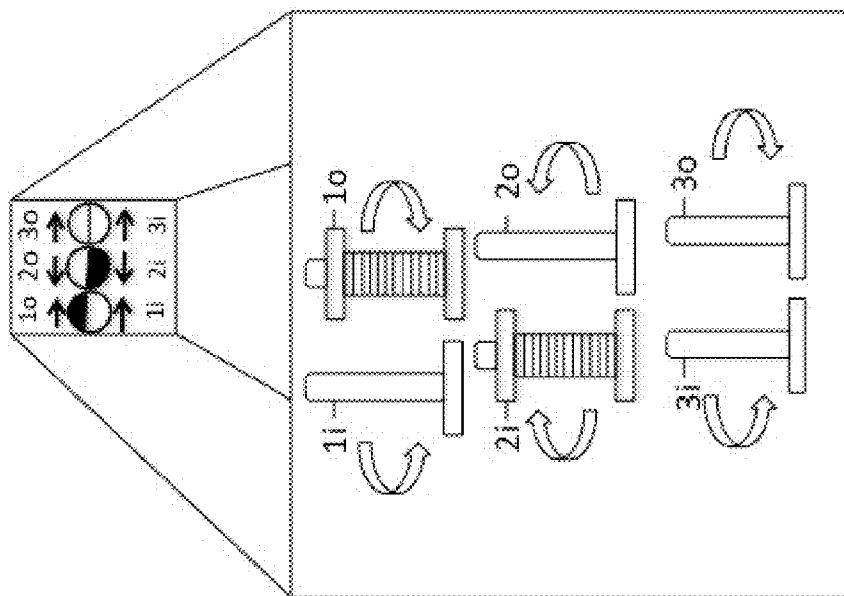
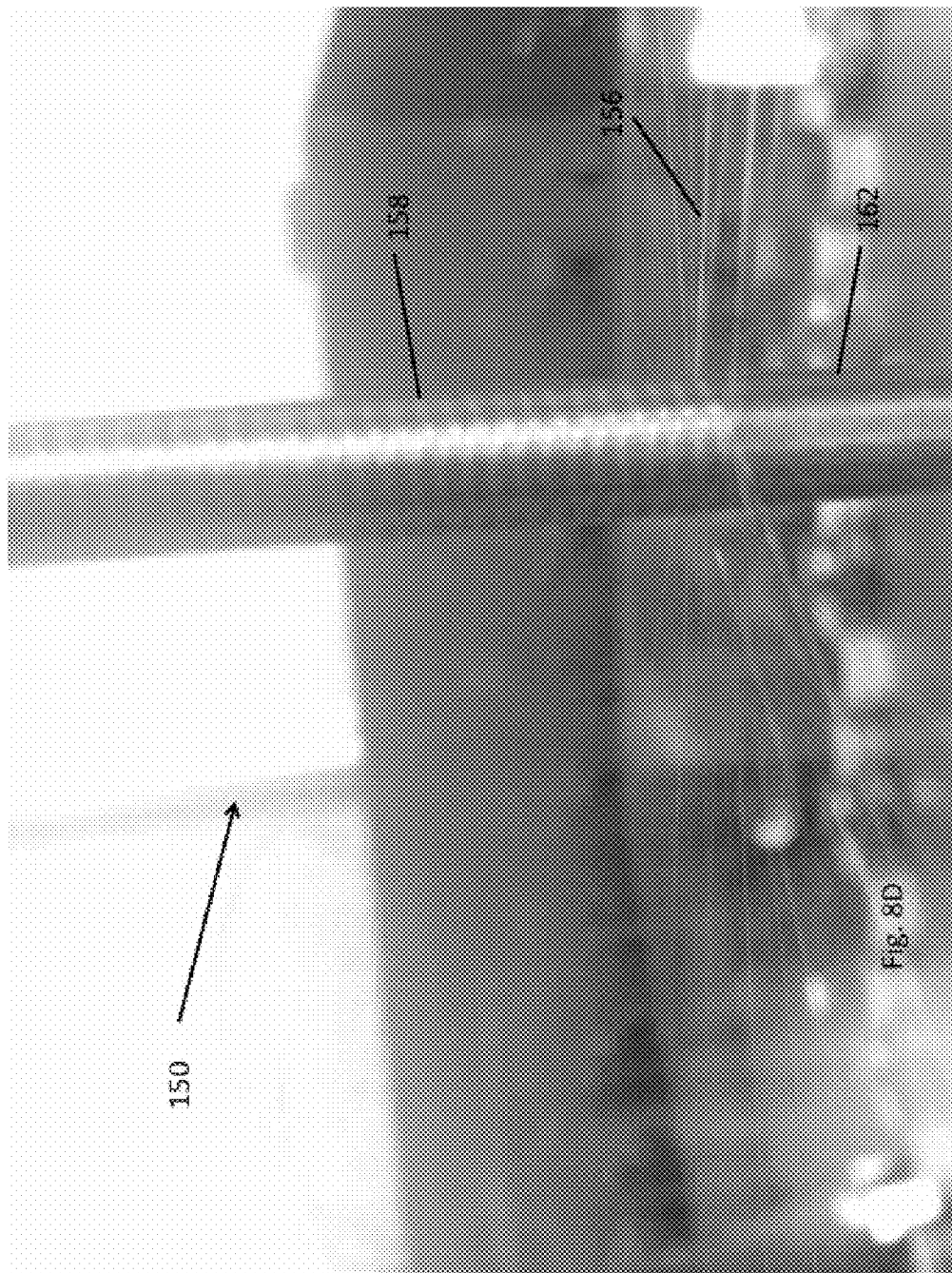


Fig. 8C



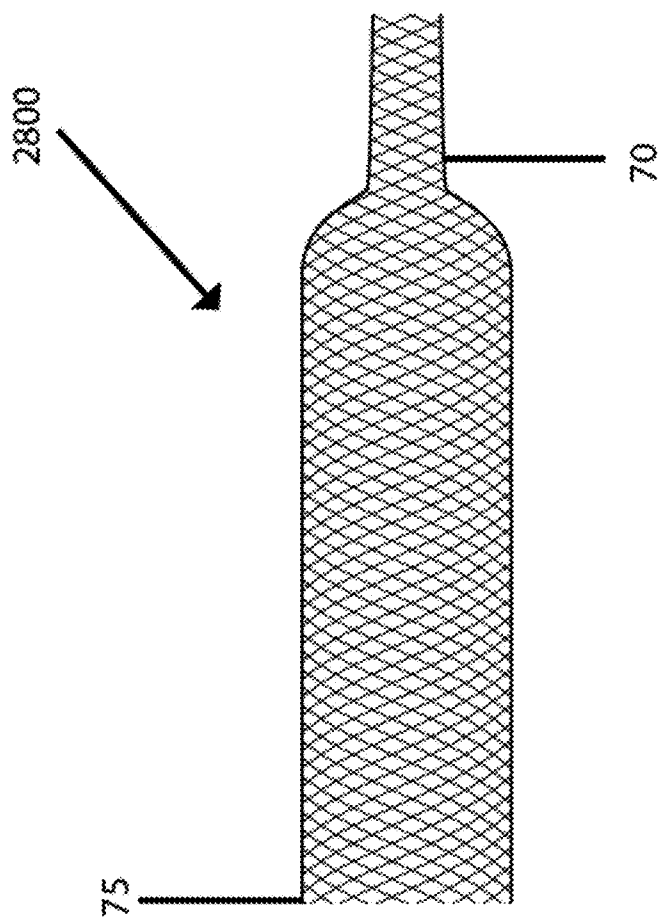


Fig. 8E

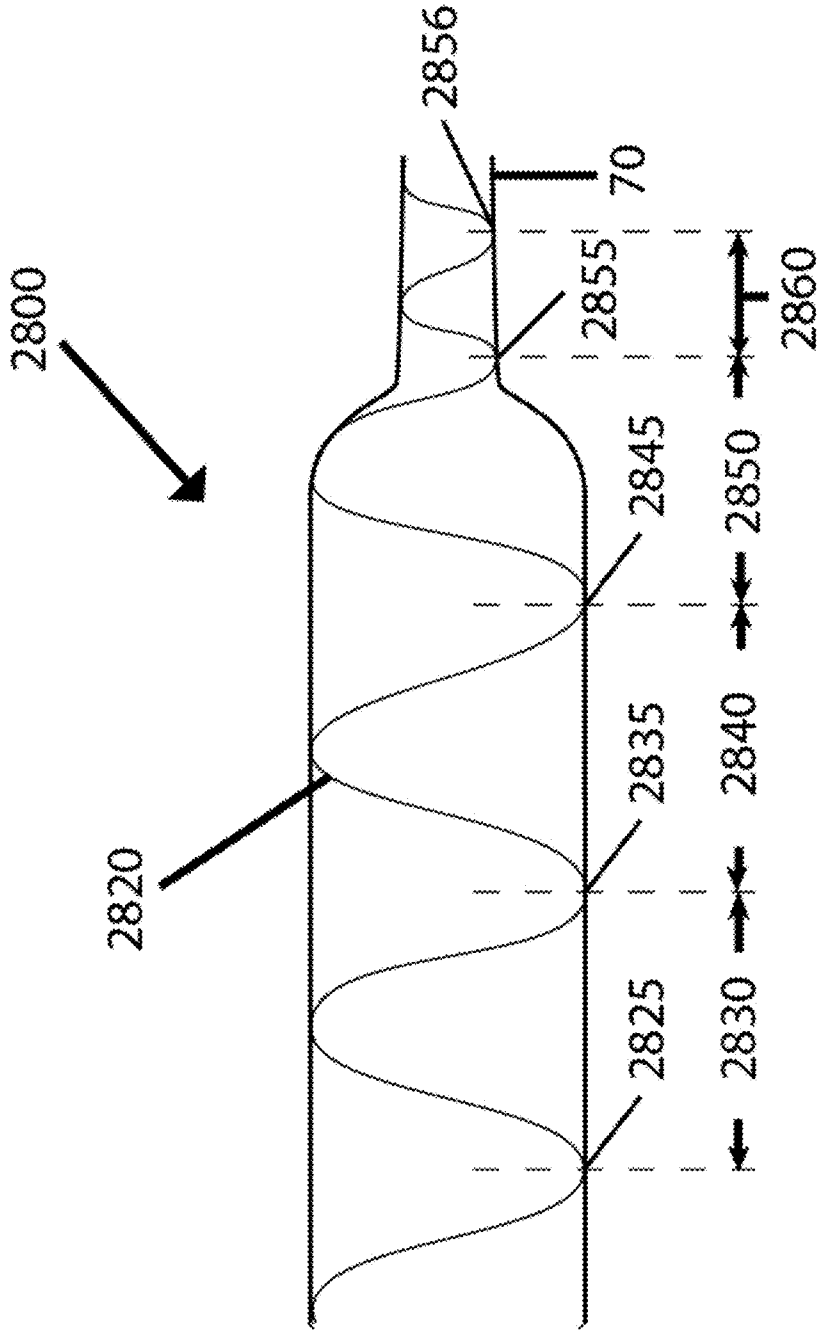


FIG. 8F

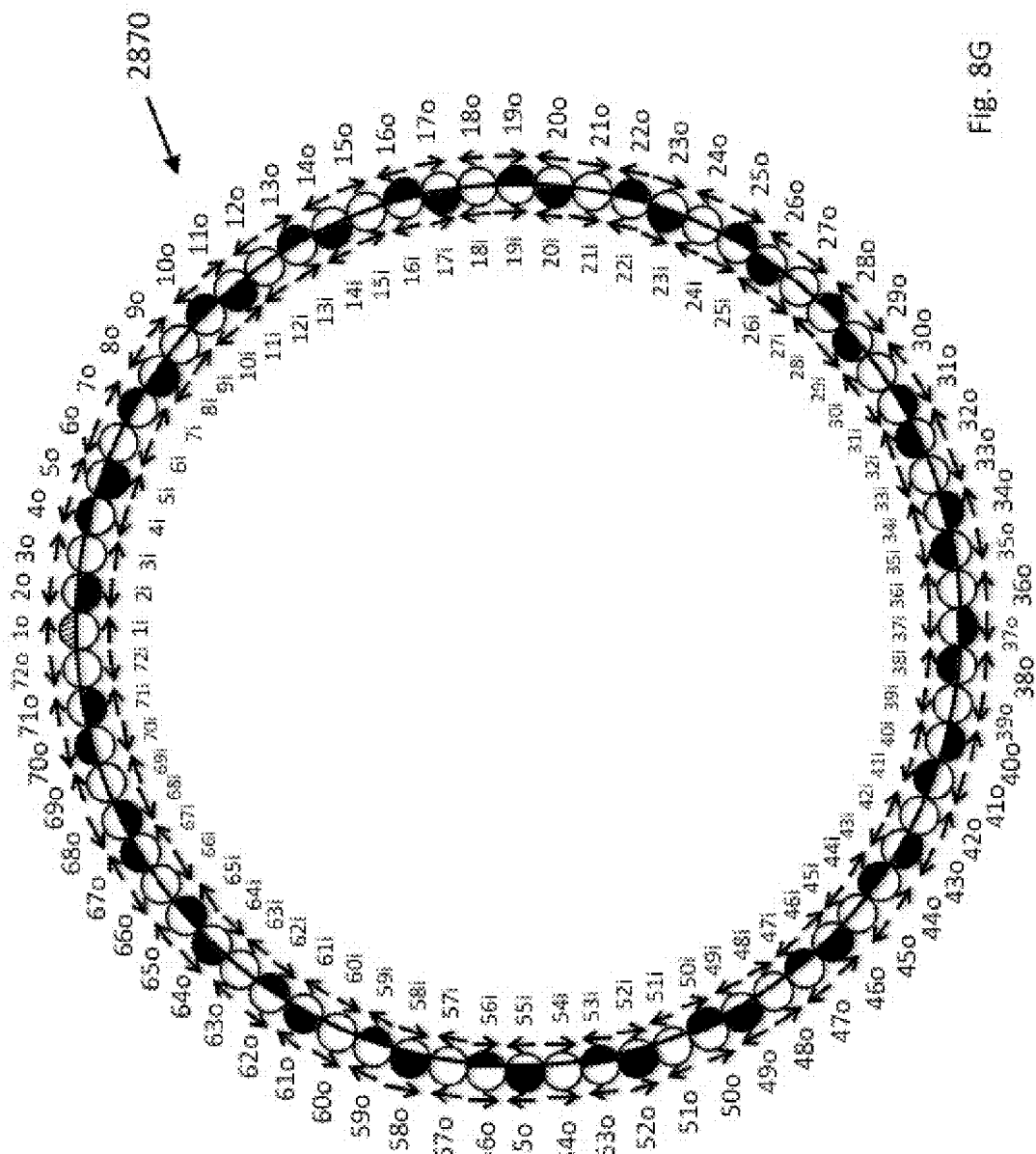


Fig. 8G

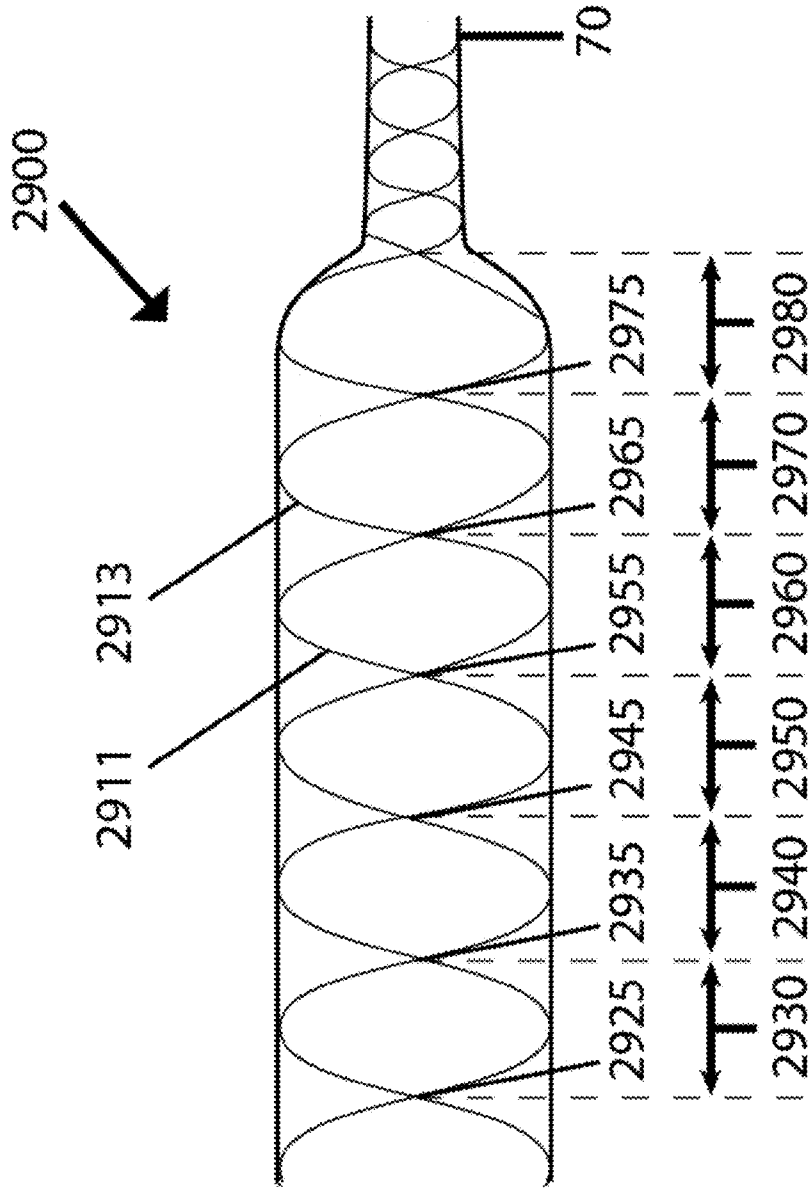


Fig. 8H



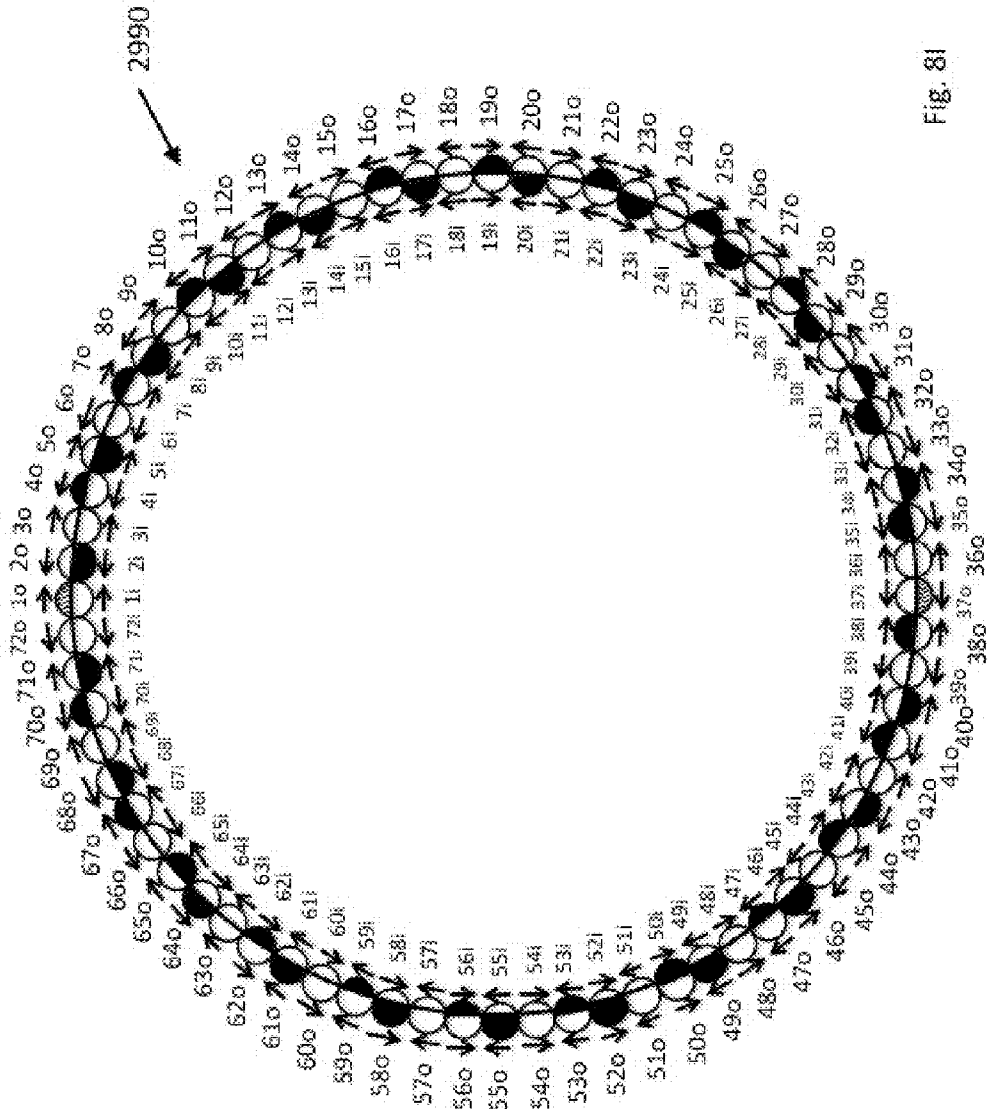


Fig. 8f

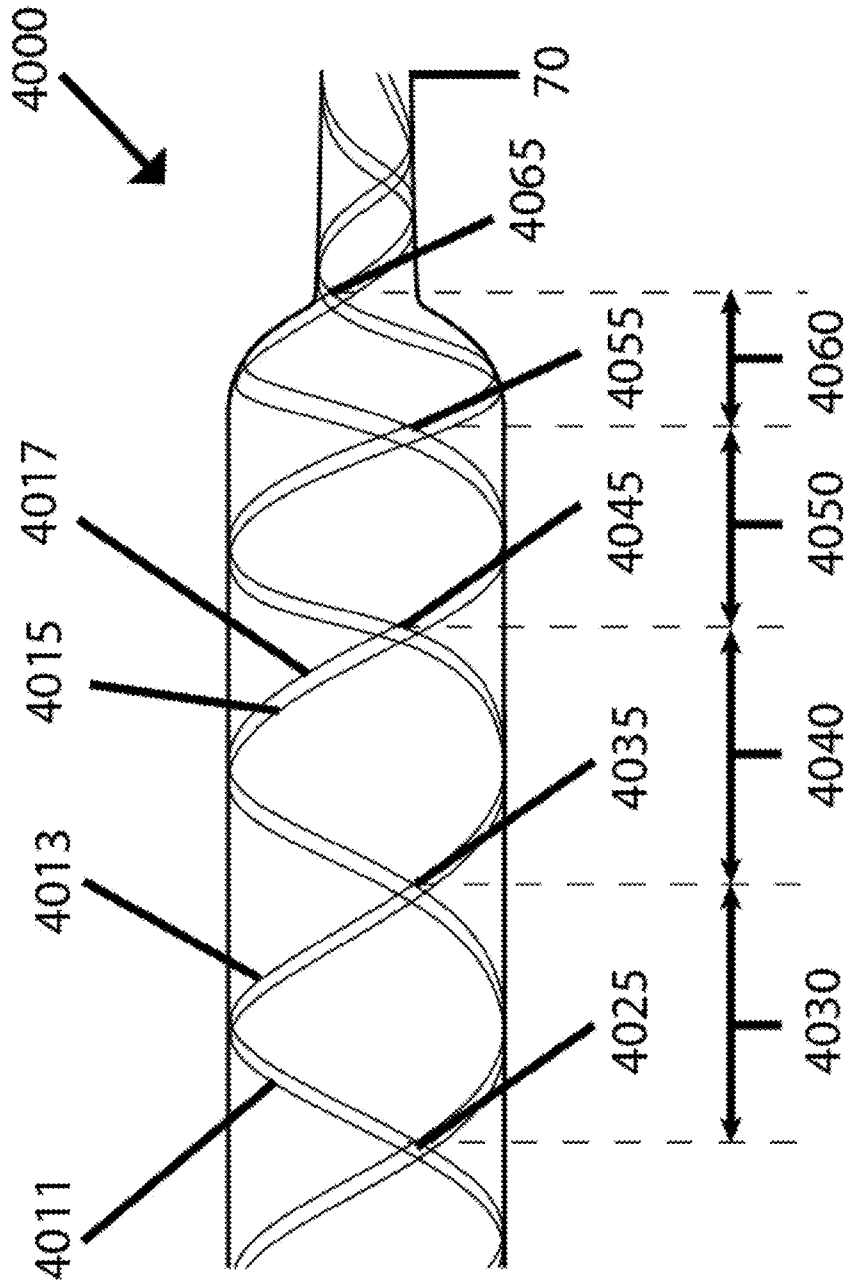


Fig. 8J

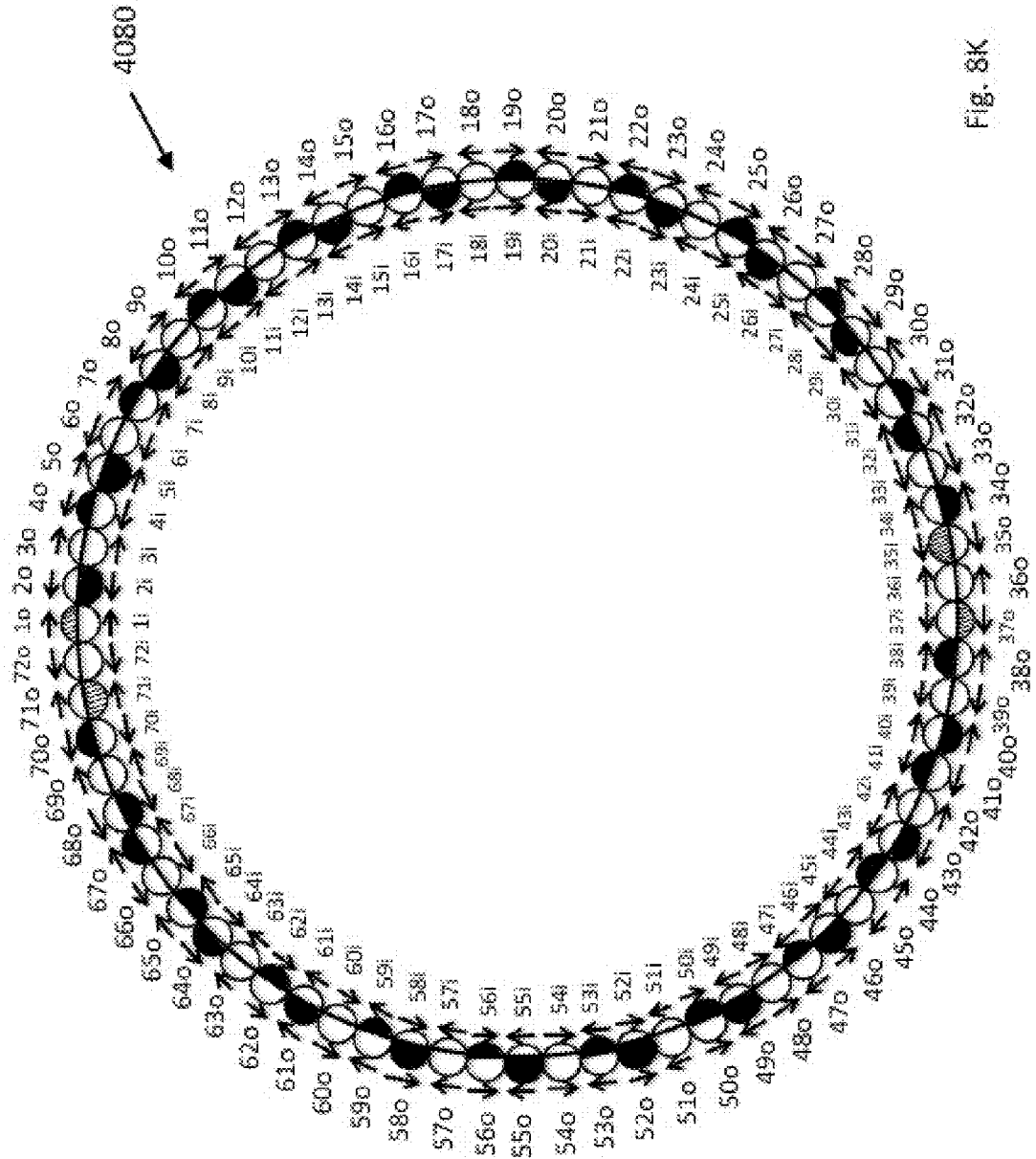


Fig. 8K

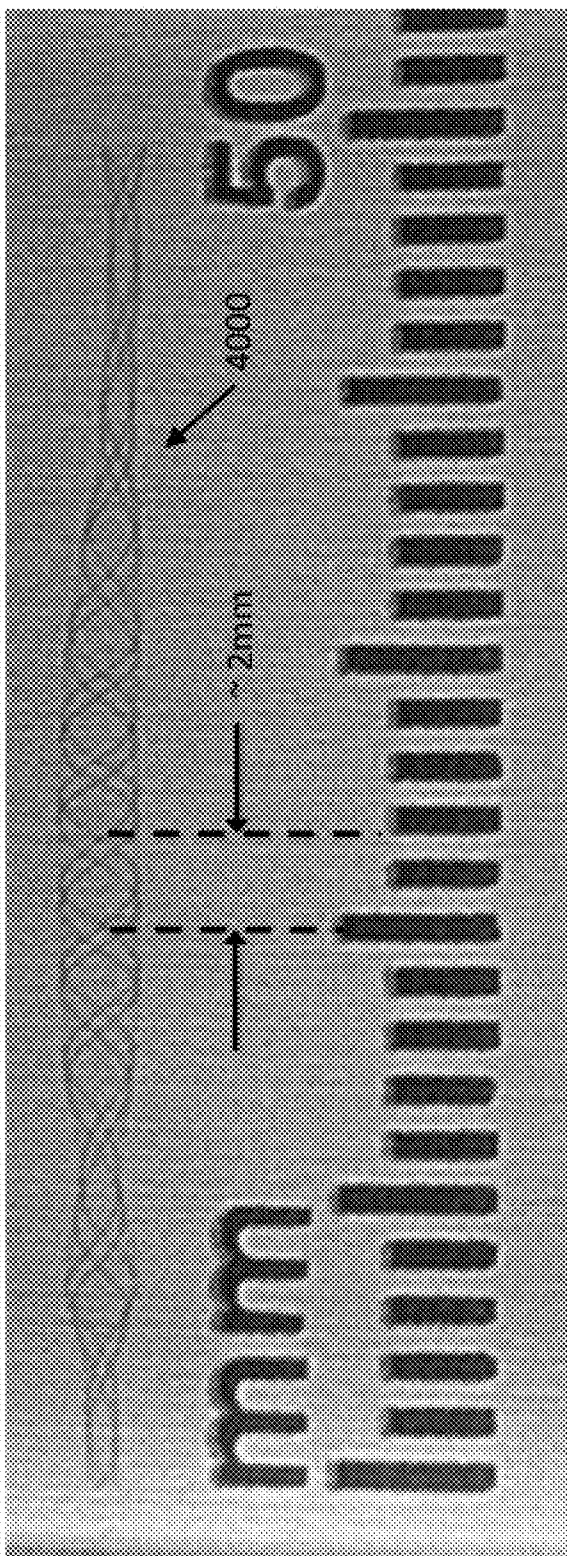


Fig. 8L

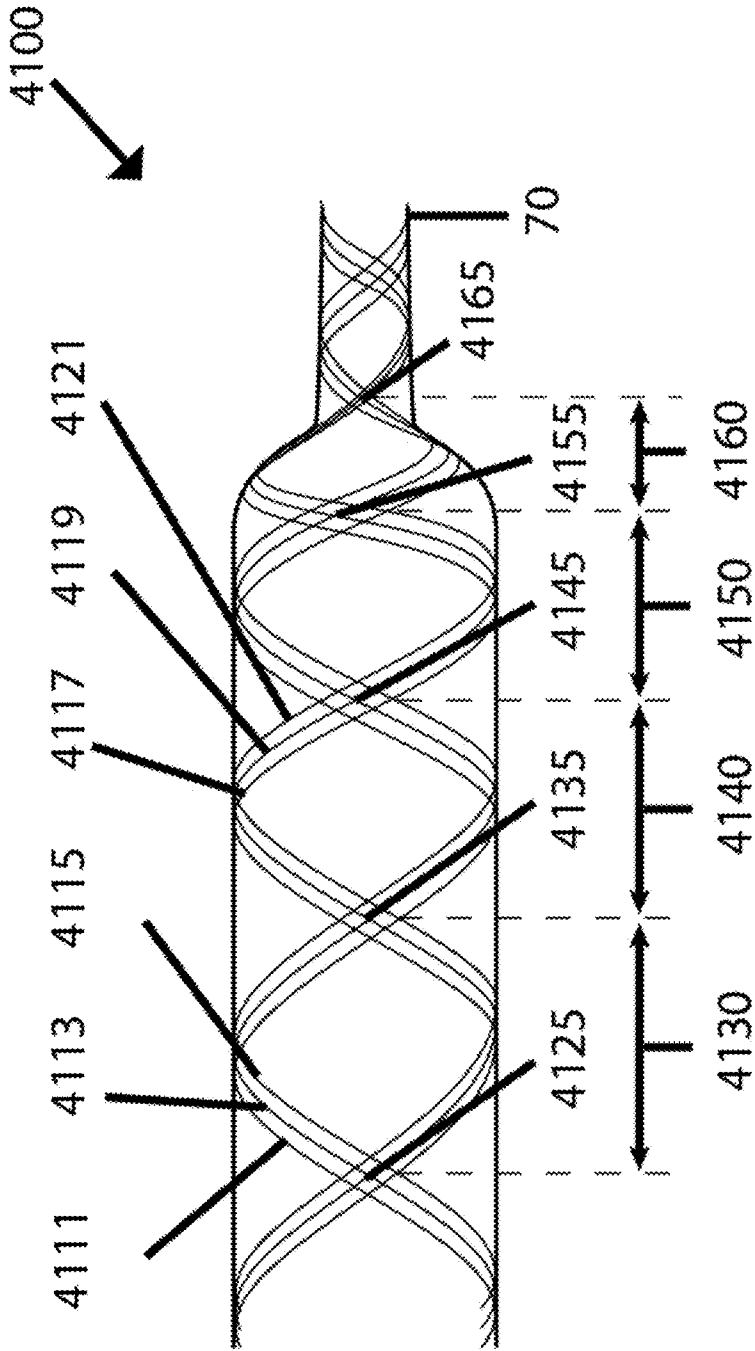


Fig. 8M

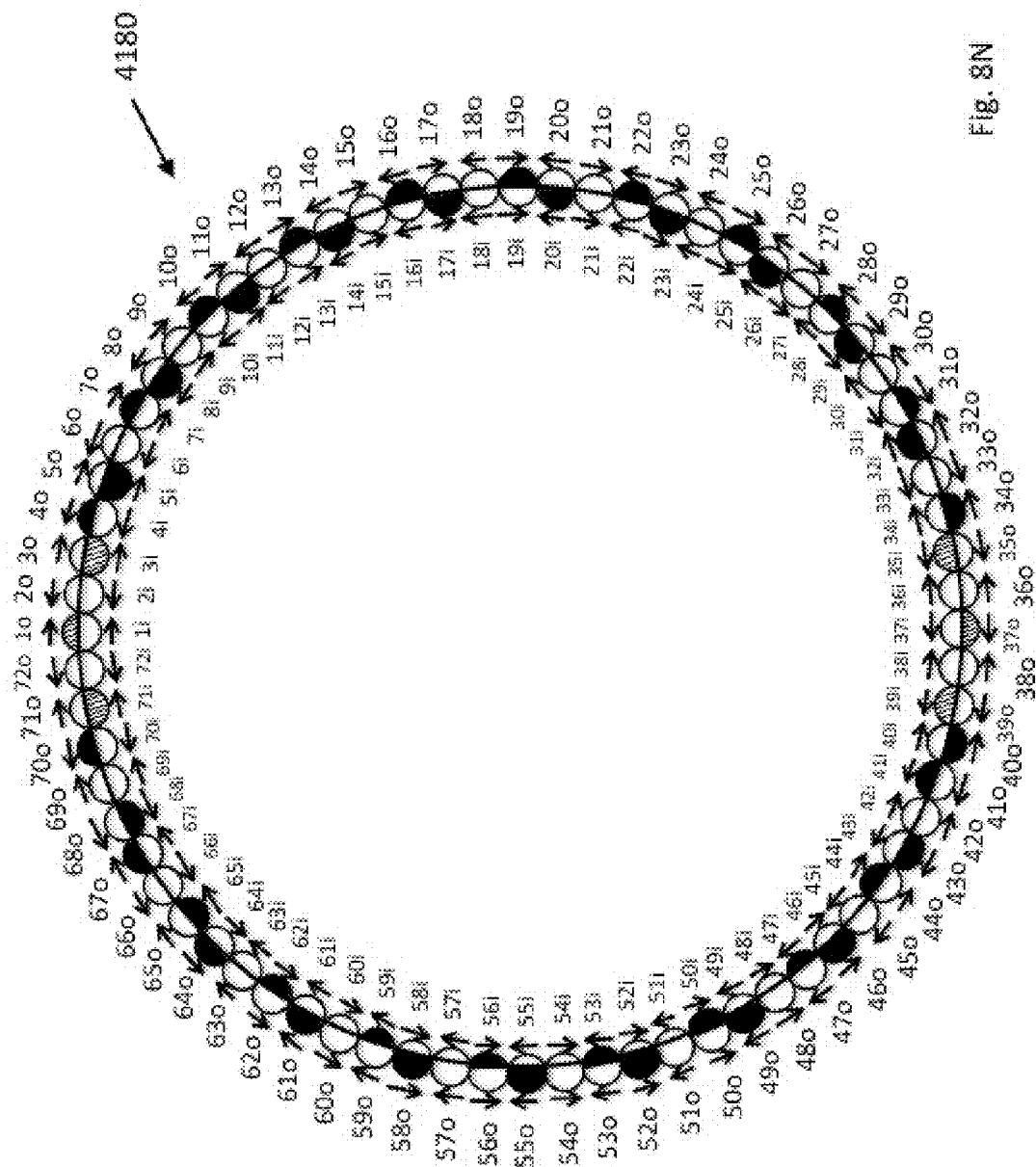
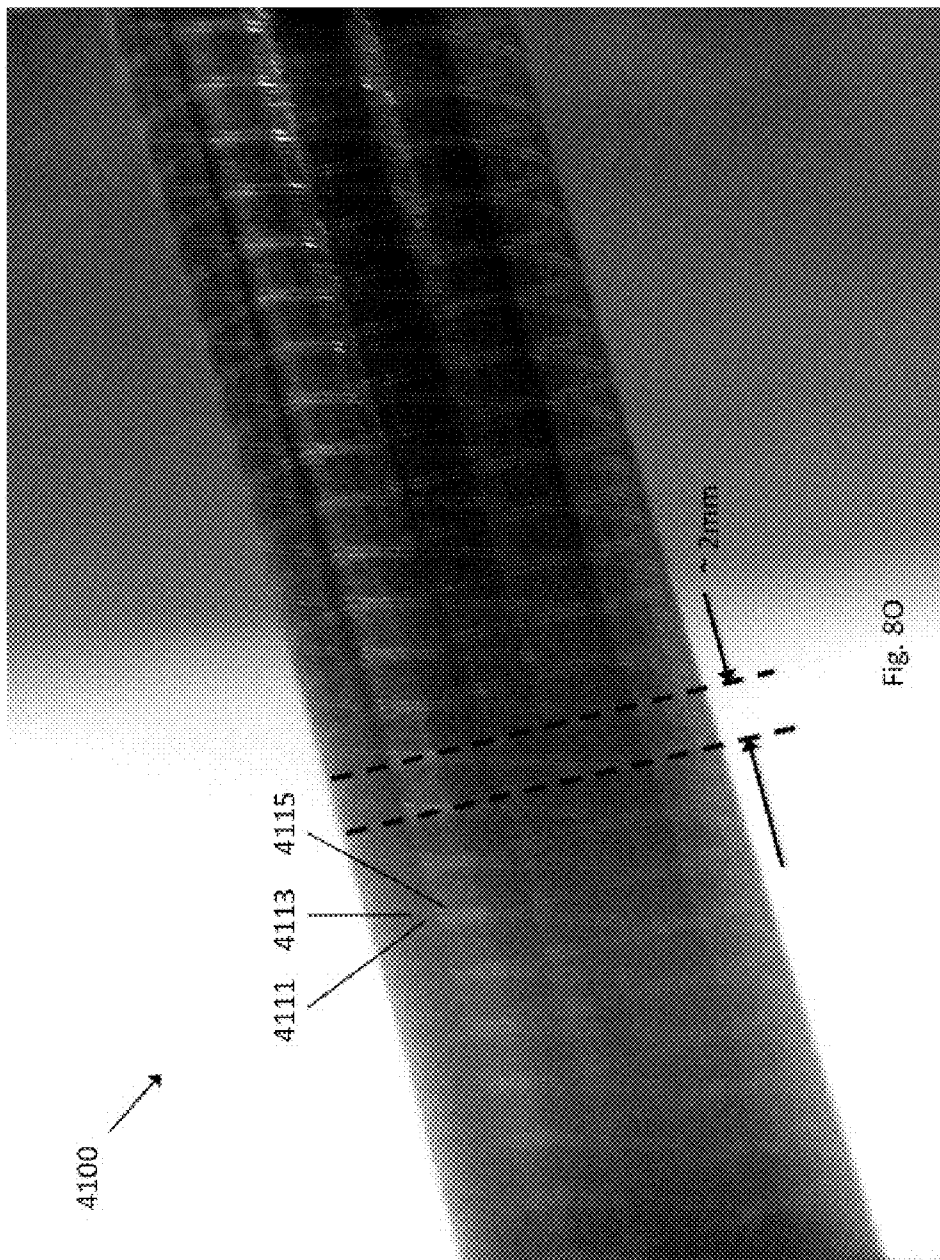


Fig. 8N



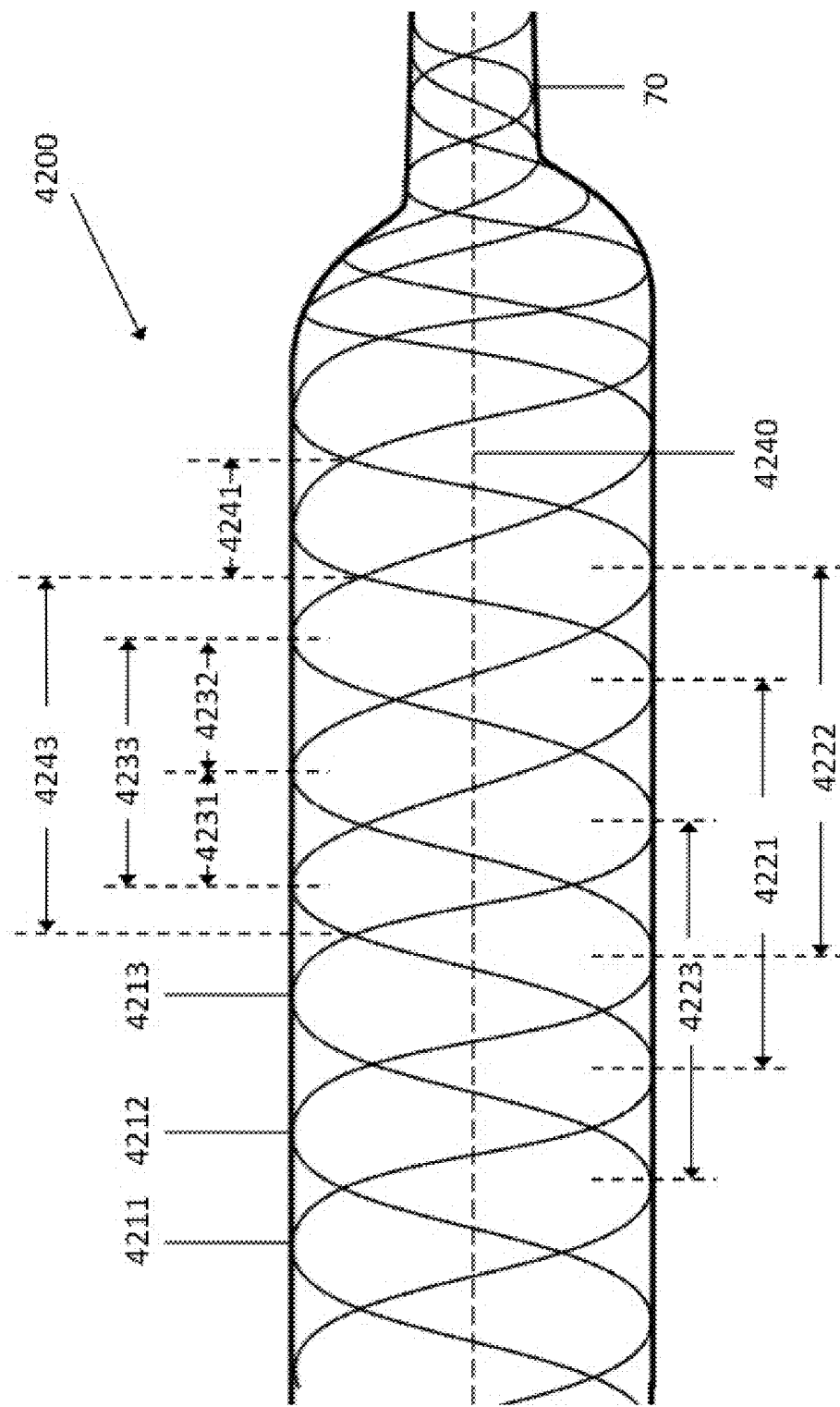


Fig. 8P



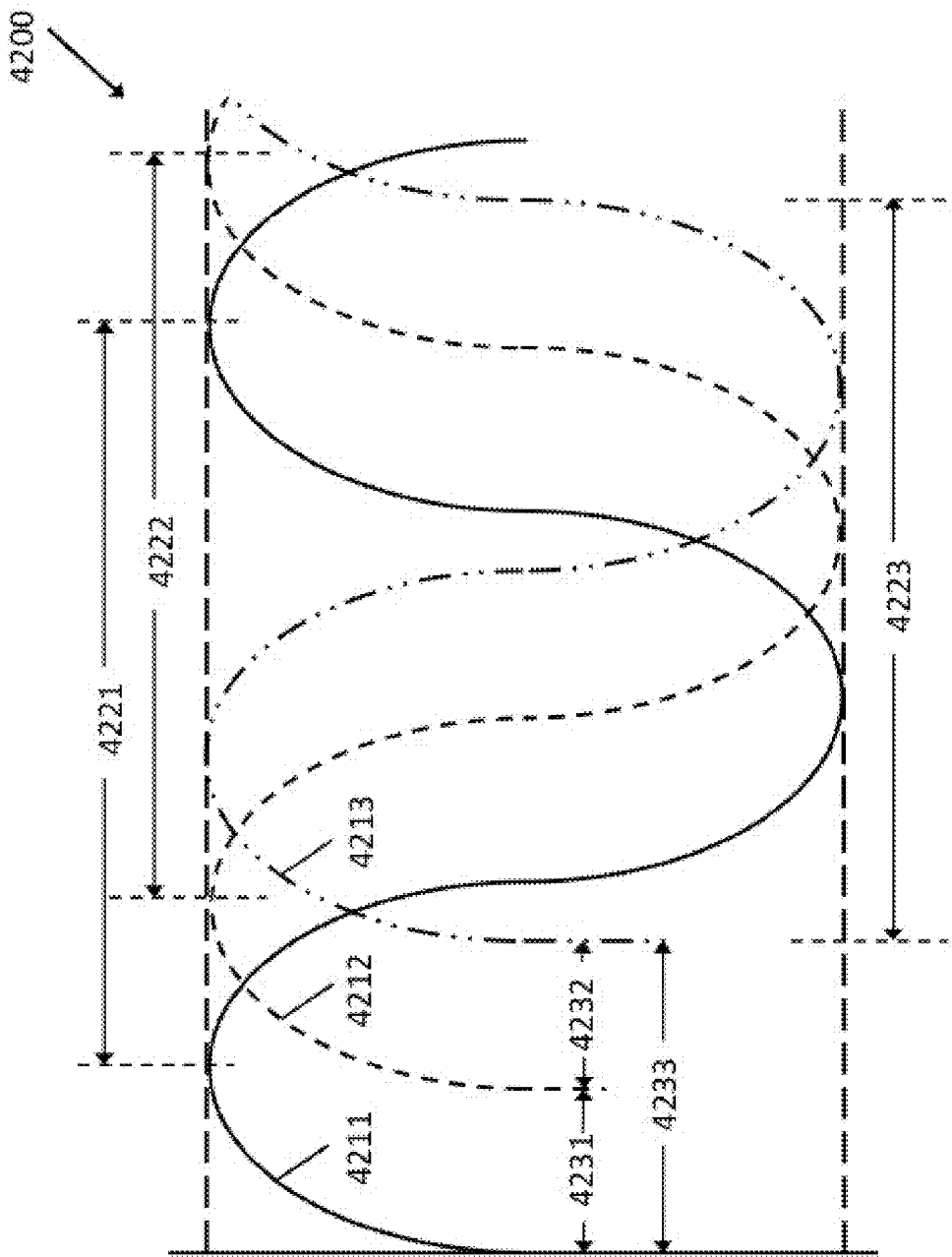


Fig. 8Q

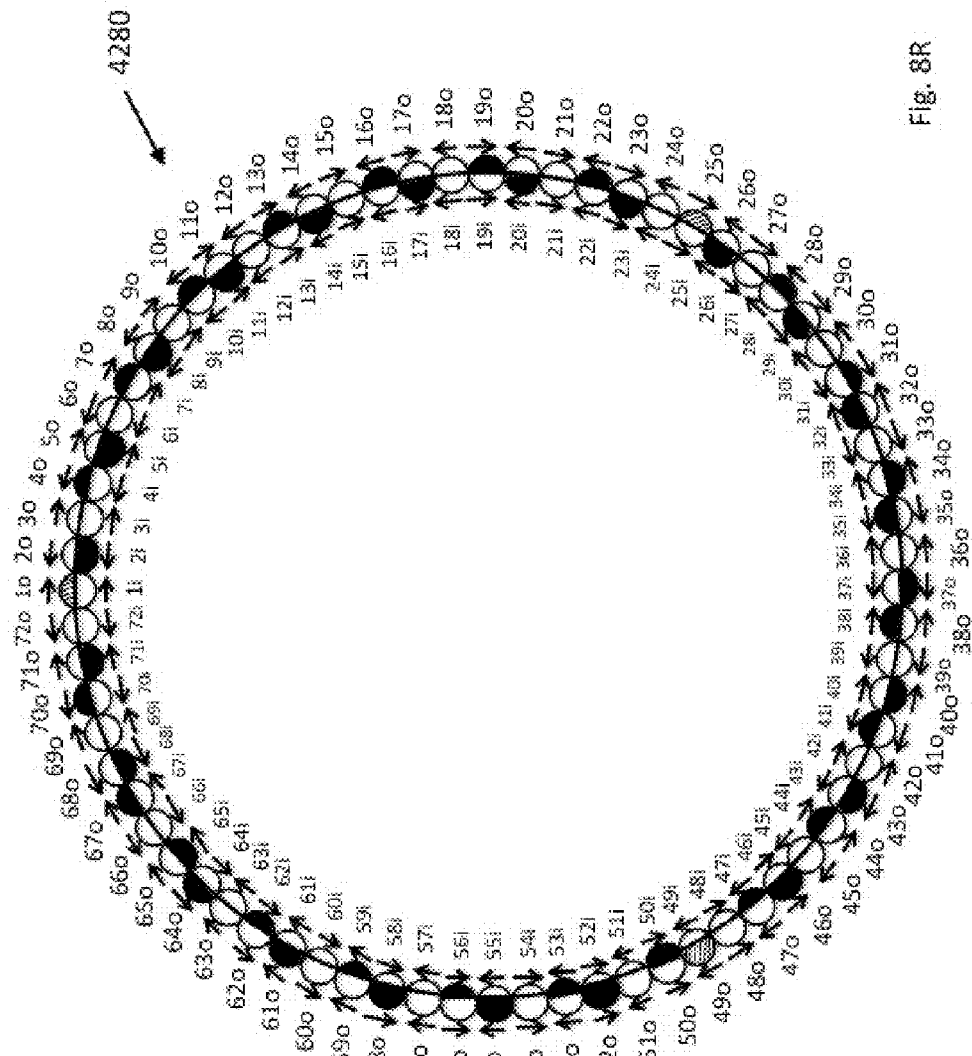


Fig. 8R

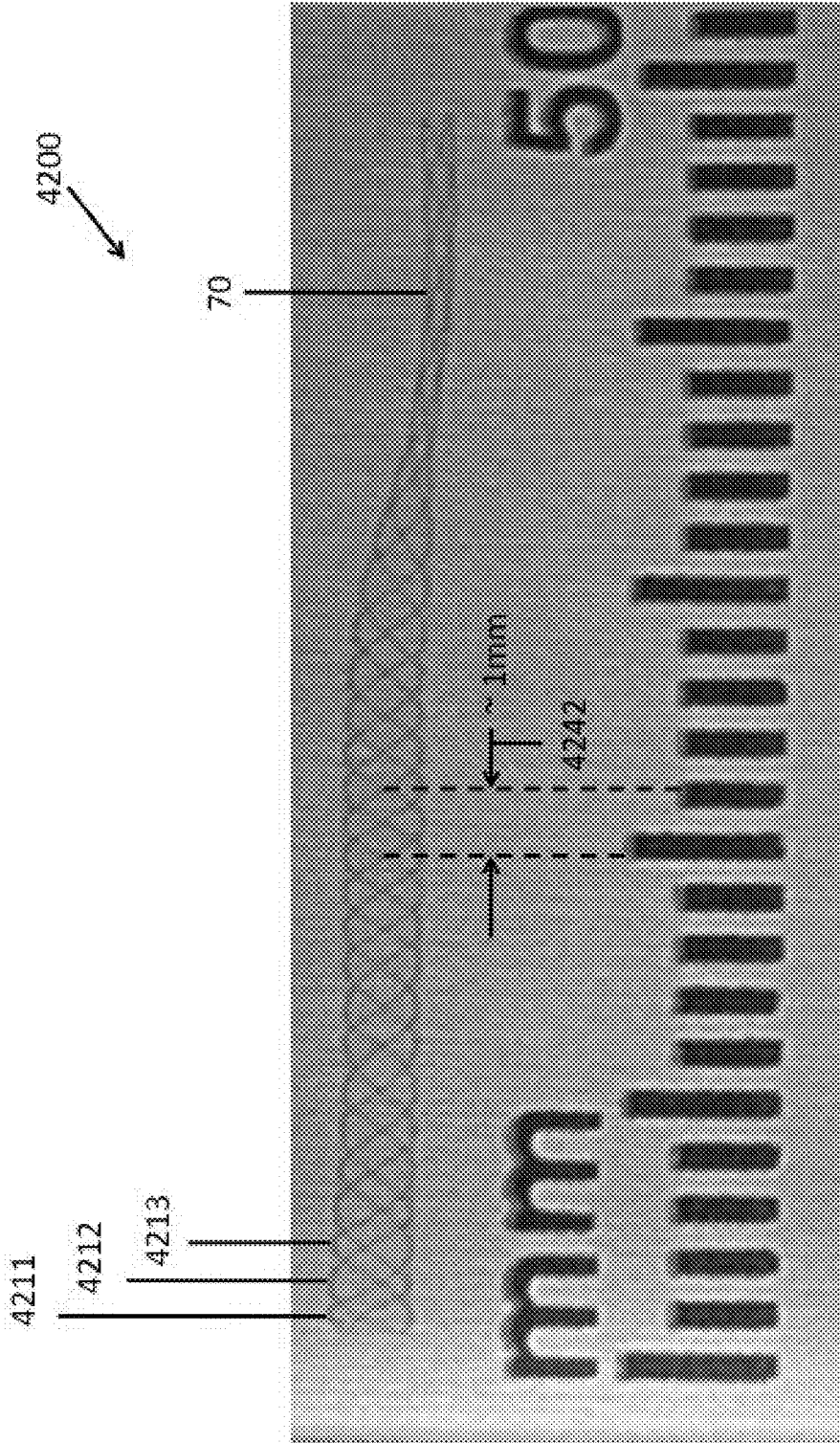


Fig. 85

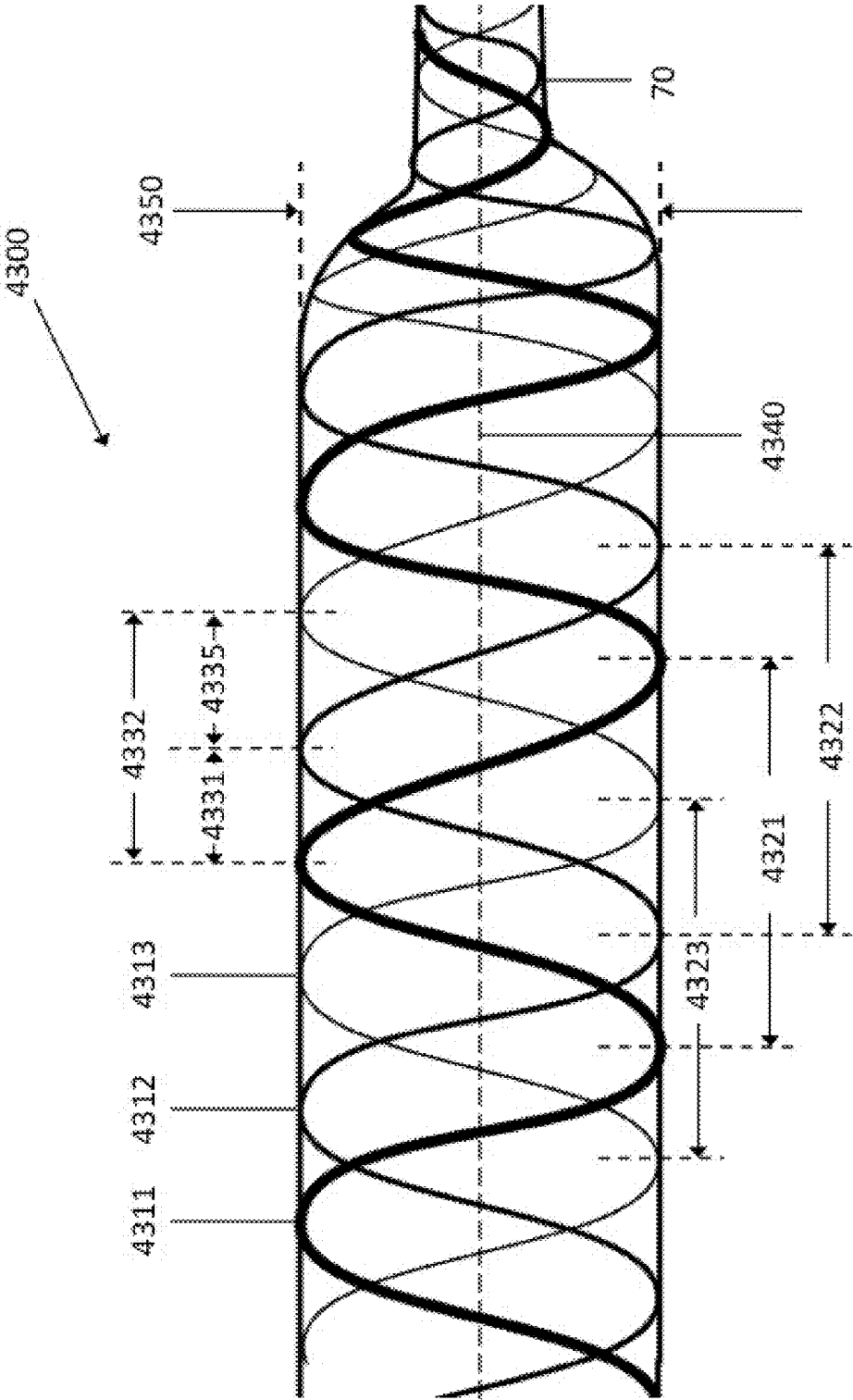


Fig. 8T-1

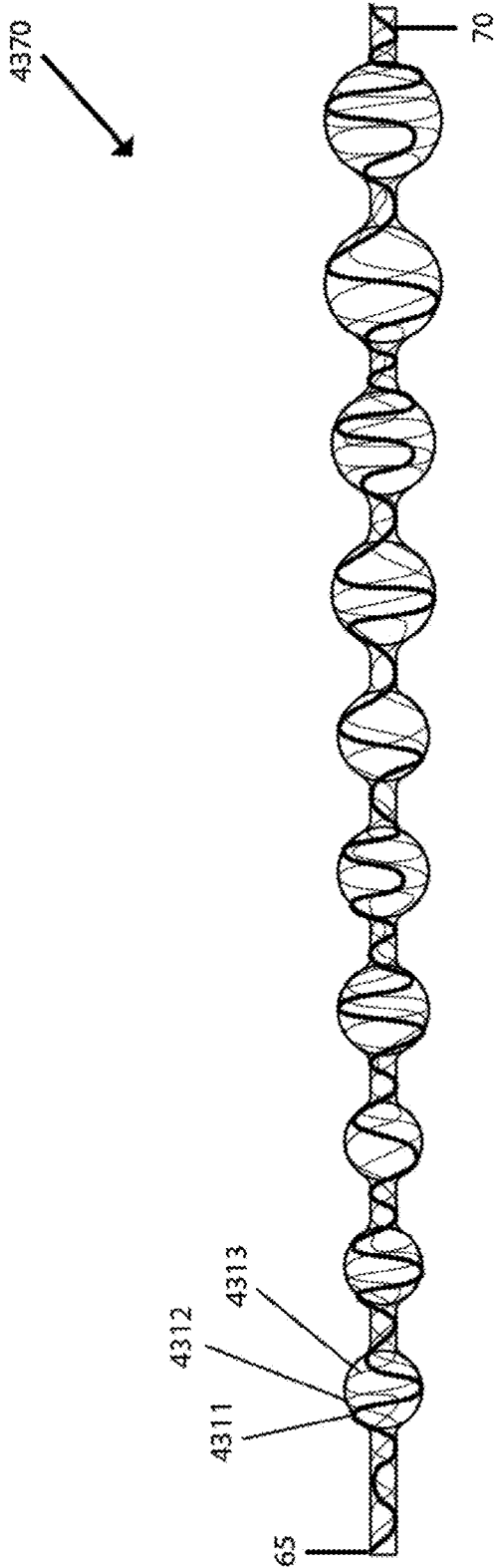
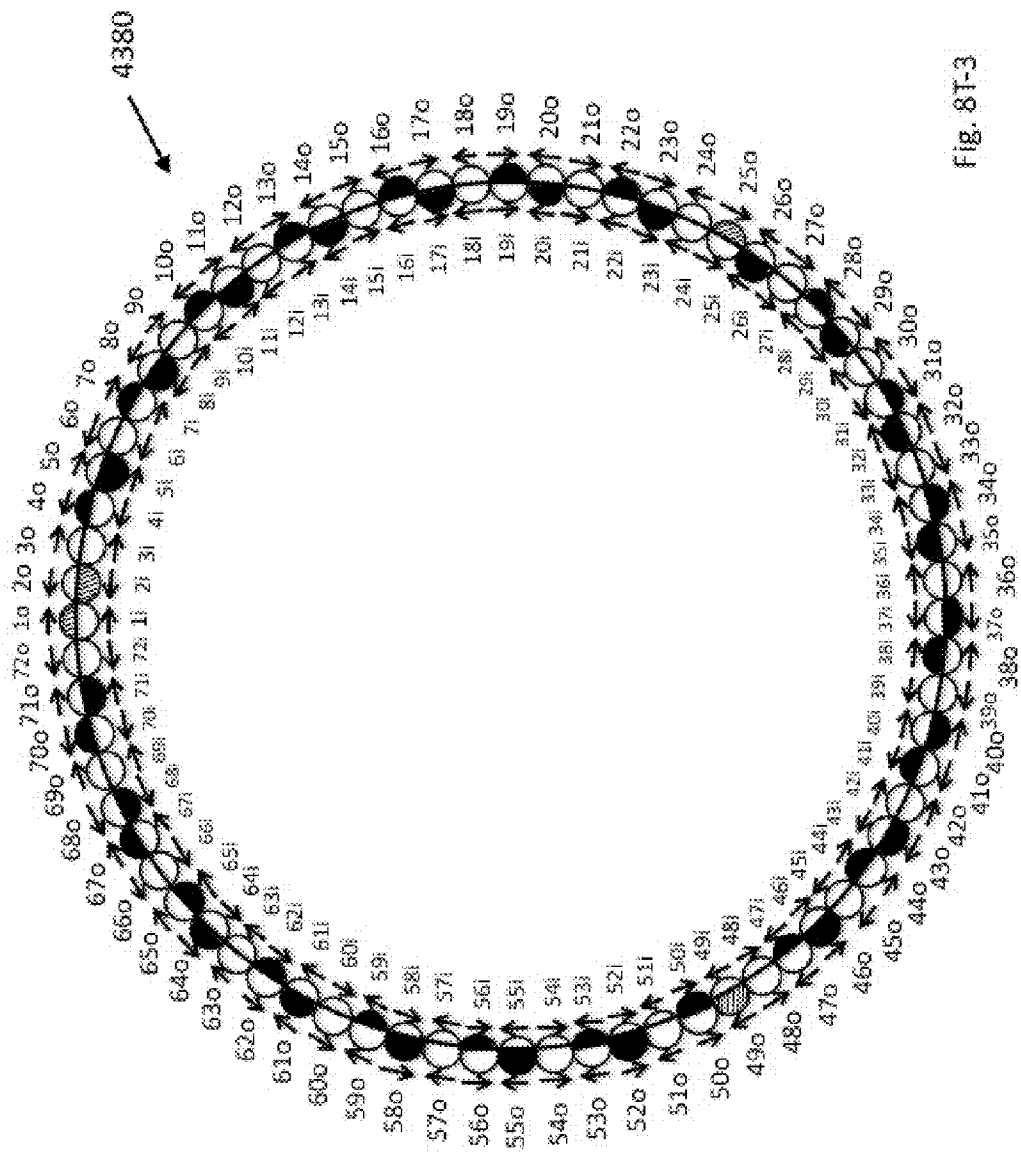


Fig. 8T-2



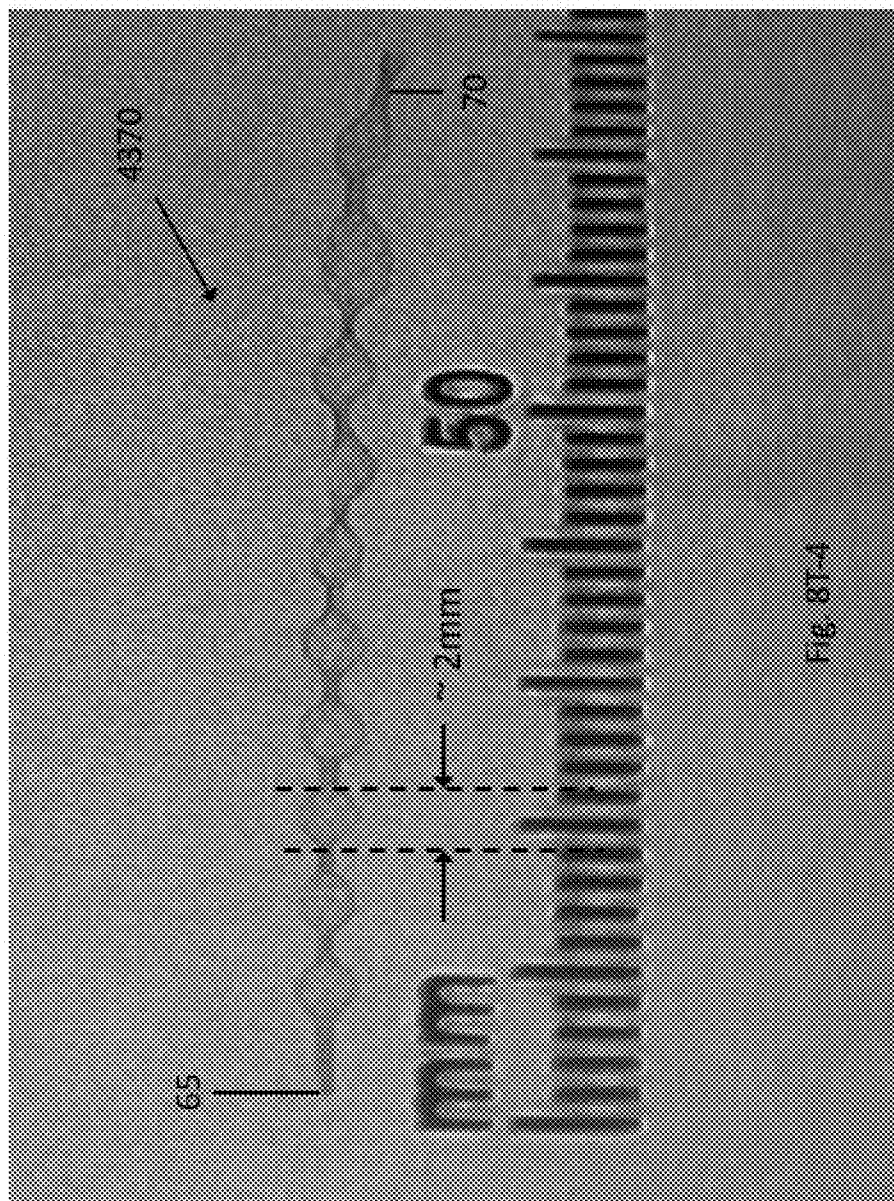


Fig. 8T-4

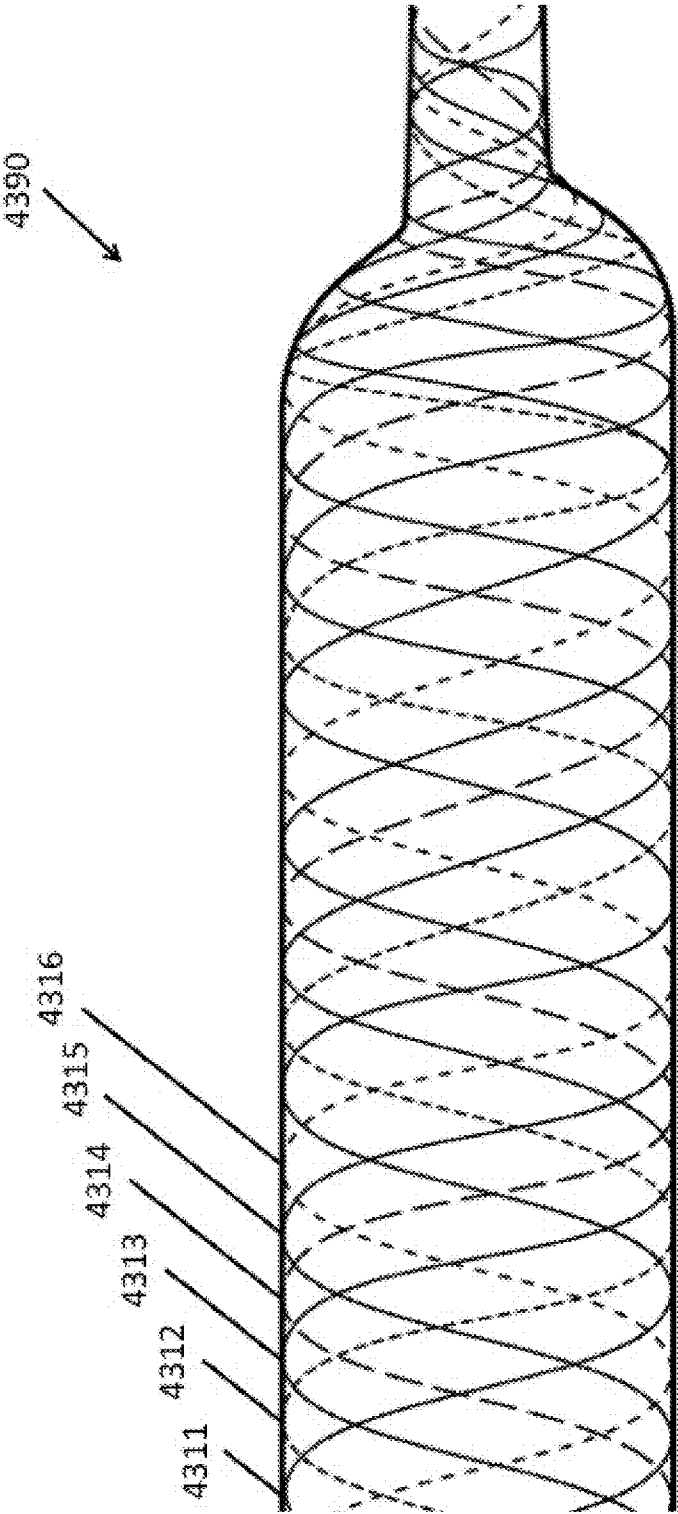


Fig. 8U



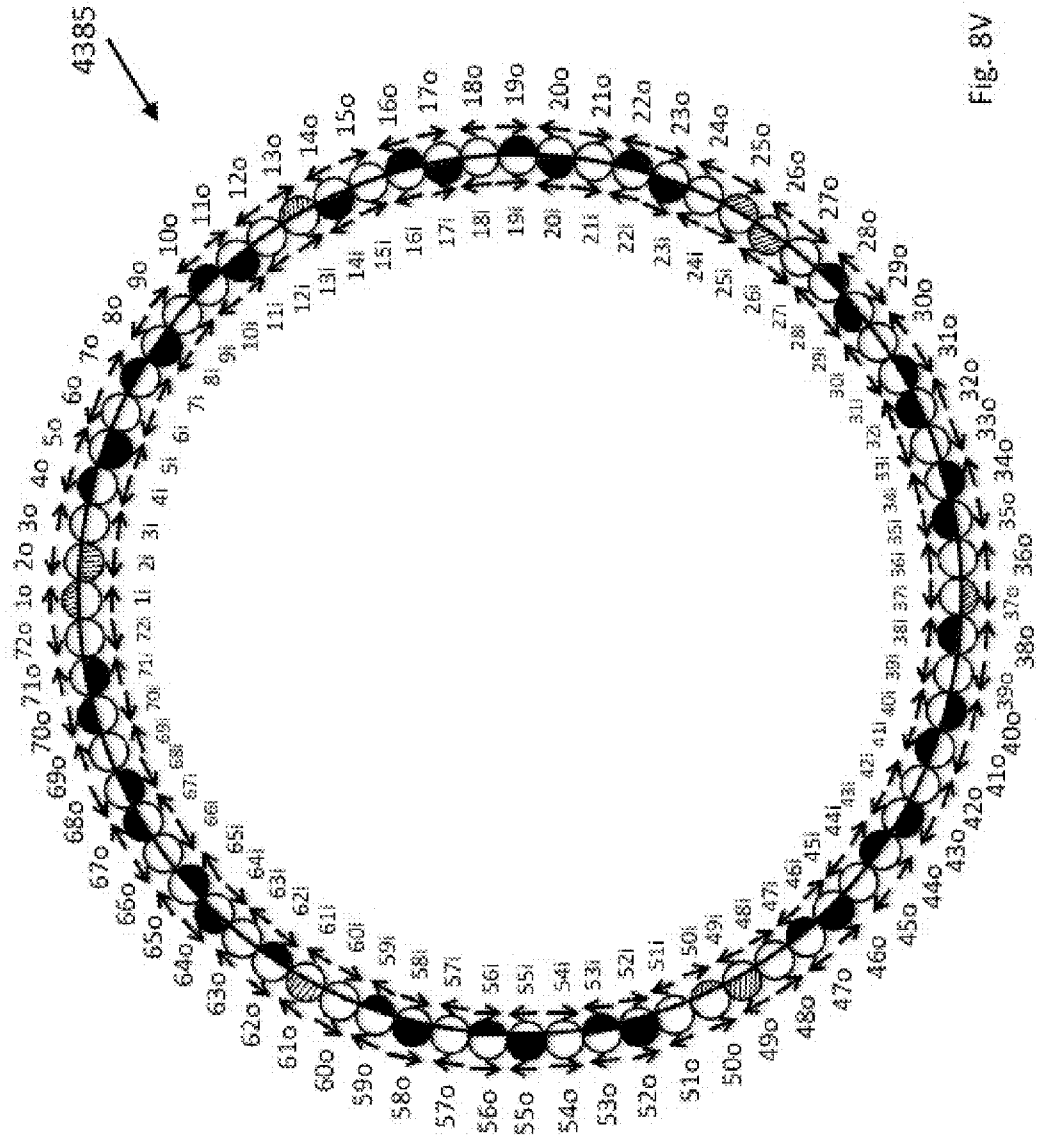


Fig. 8V

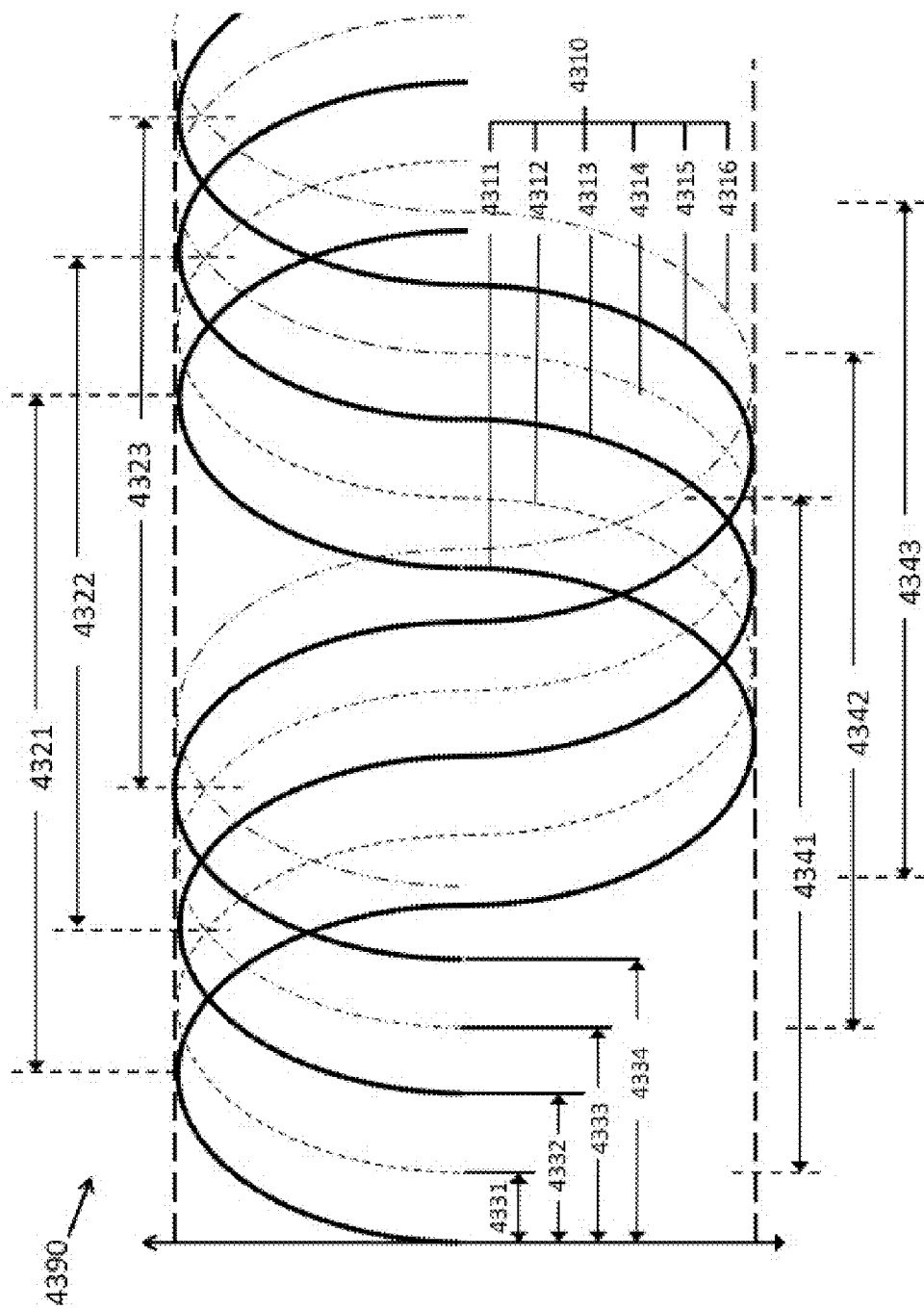


Fig. 8W

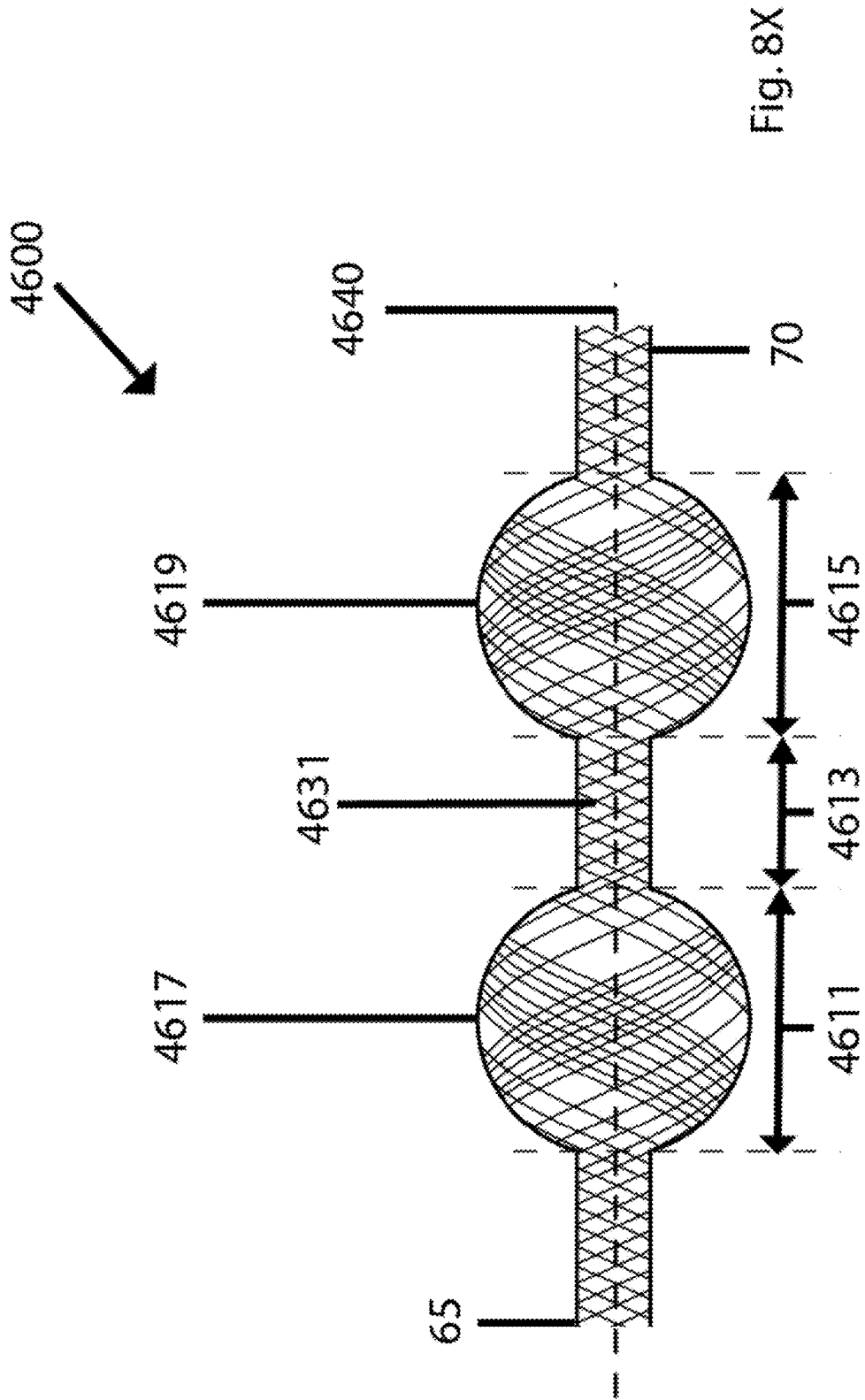


Fig. 8X

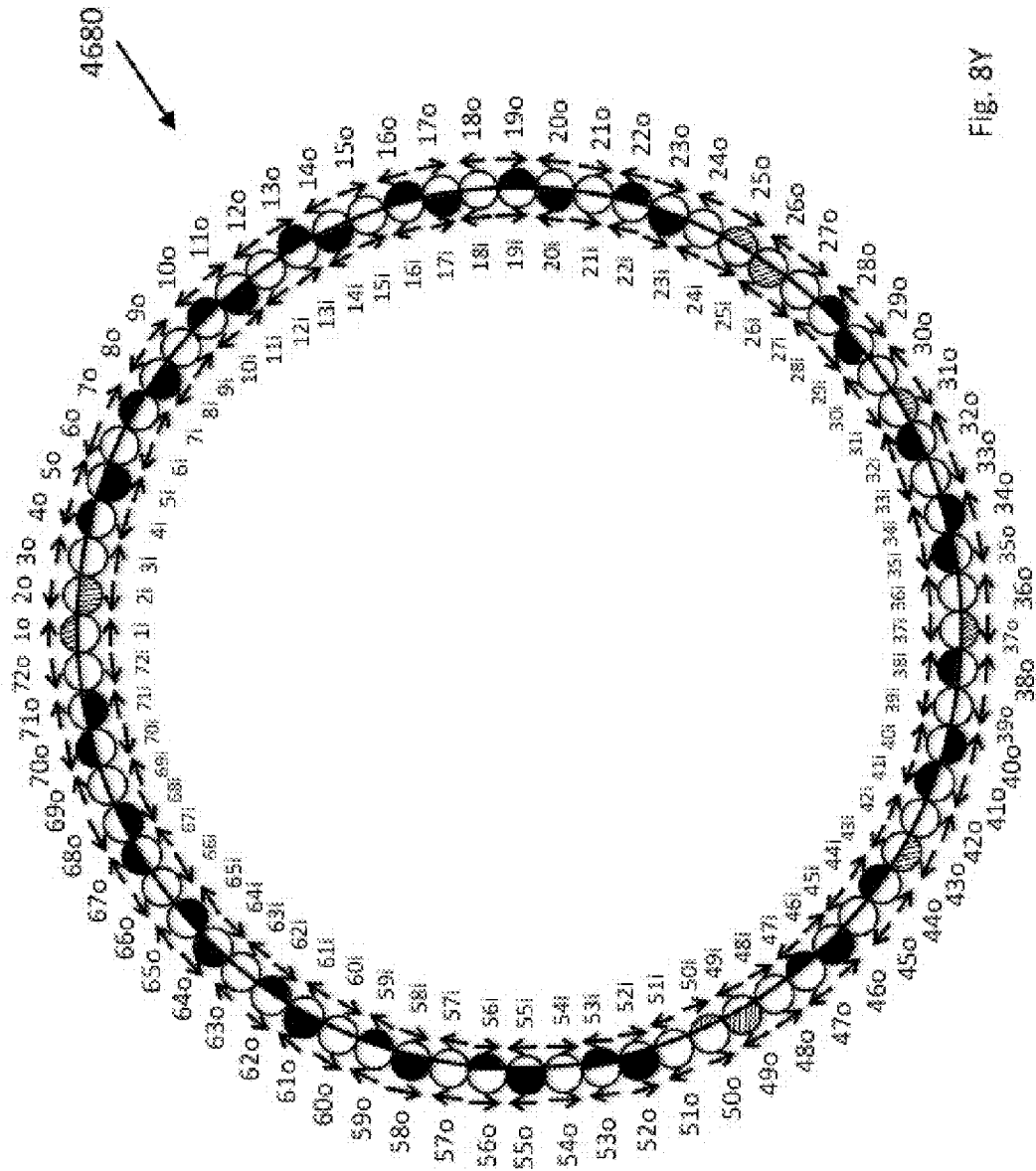


Fig. 8Y

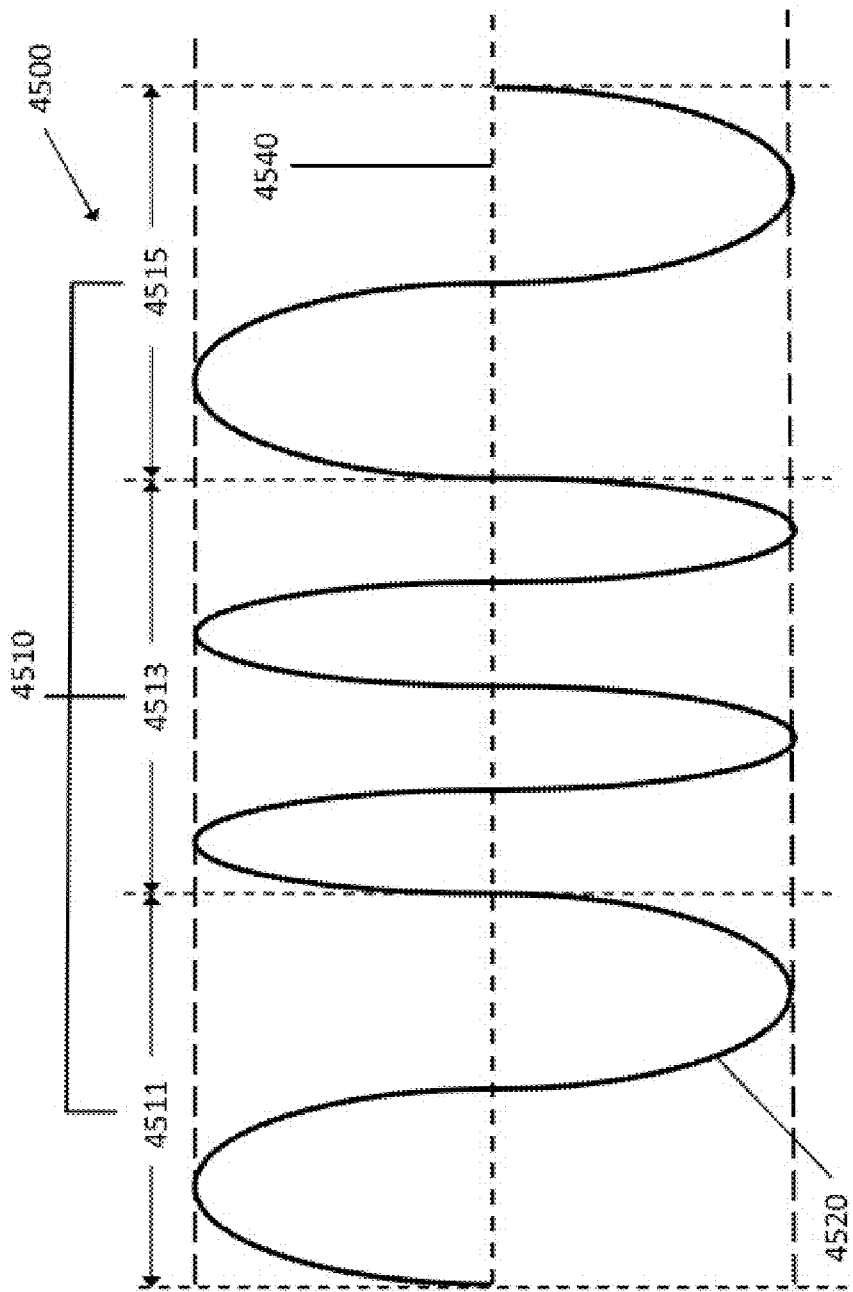


FIG. 8Z

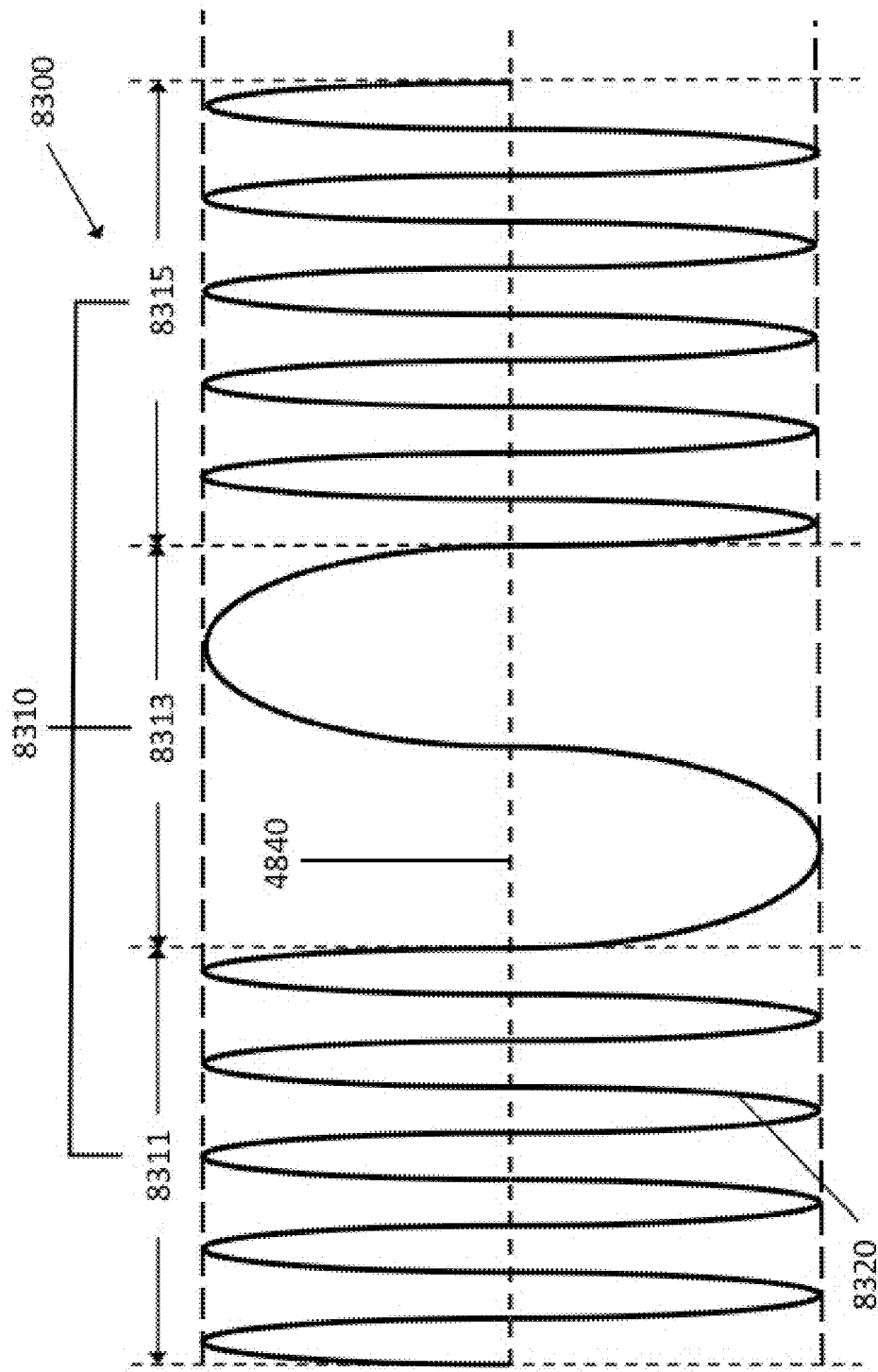


Fig. 9A

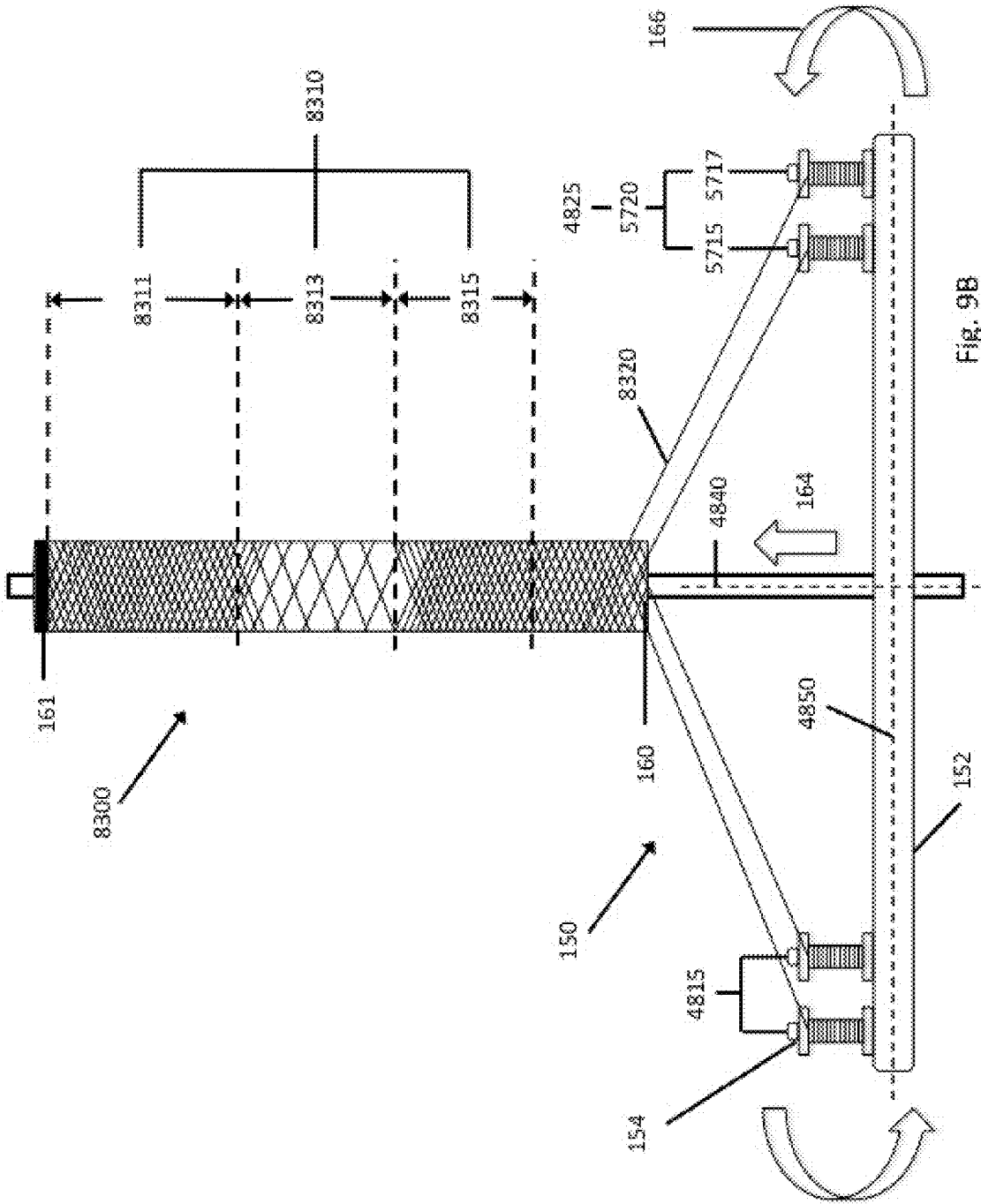


Fig. 9B

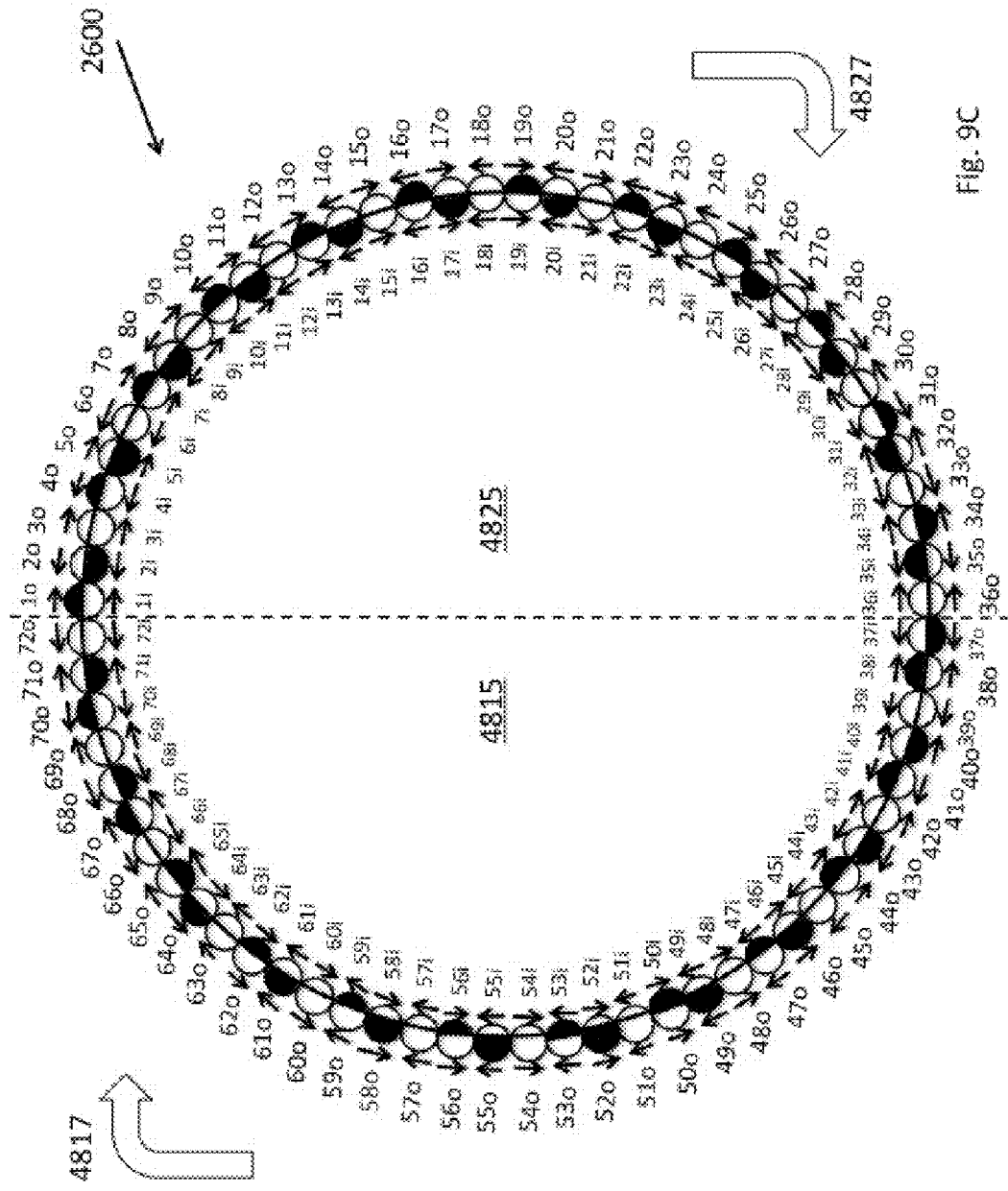


FIG. 9C



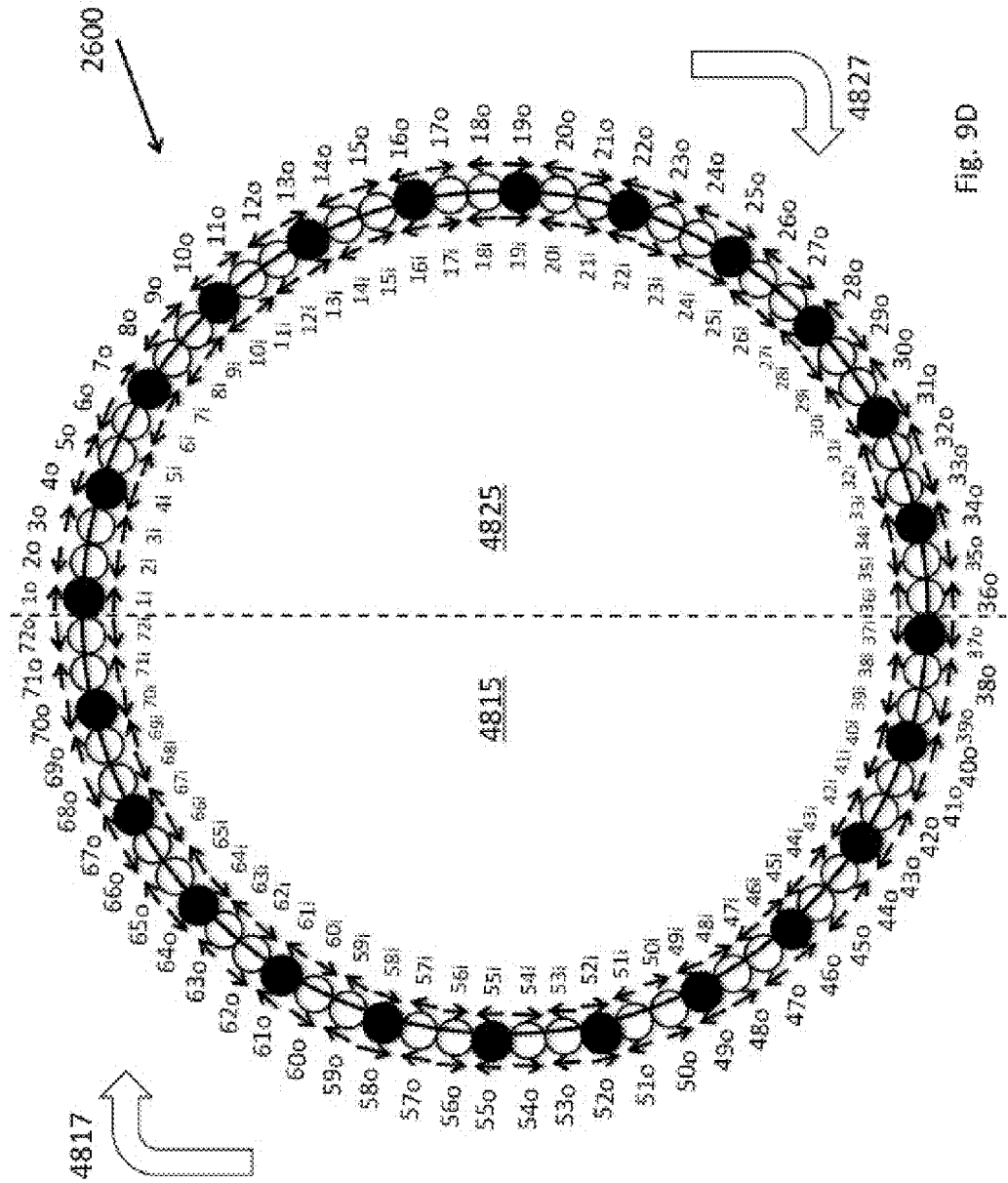


Fig. 9D

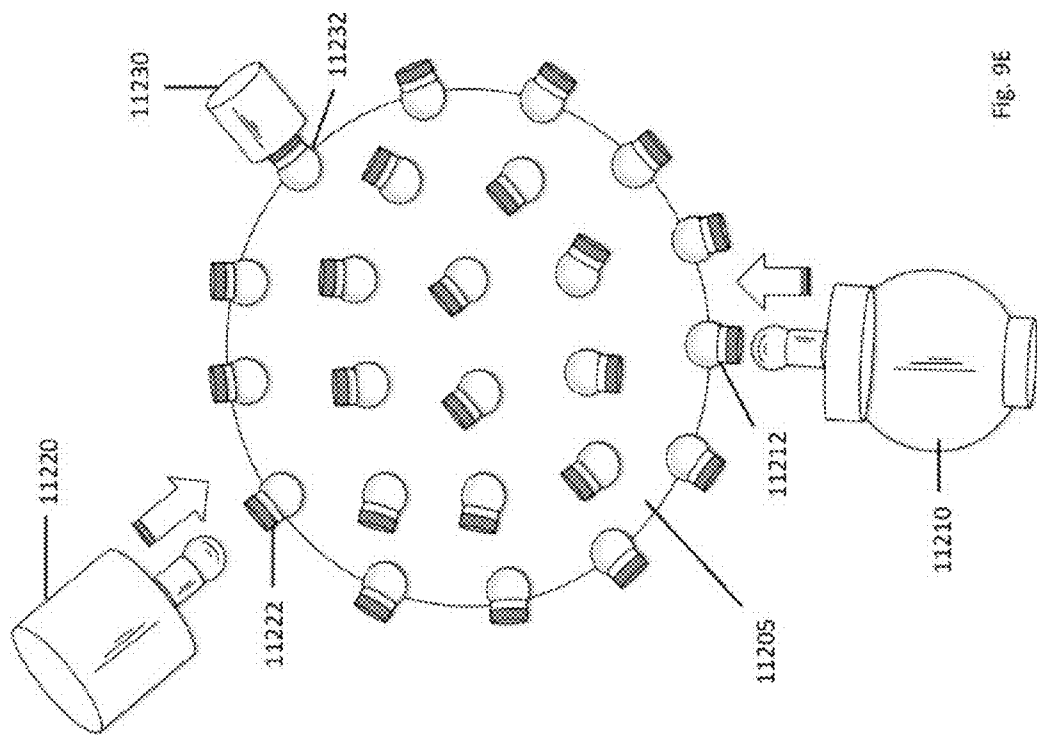


FIG. 9E

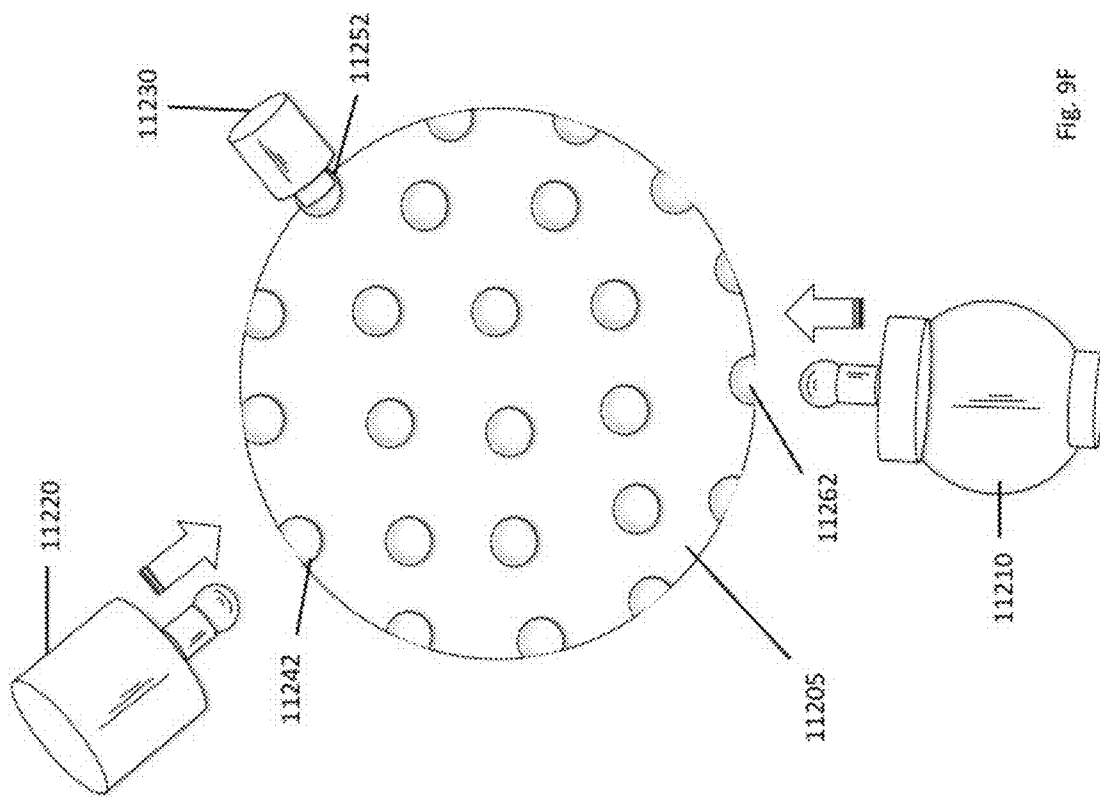


FIG. 9F

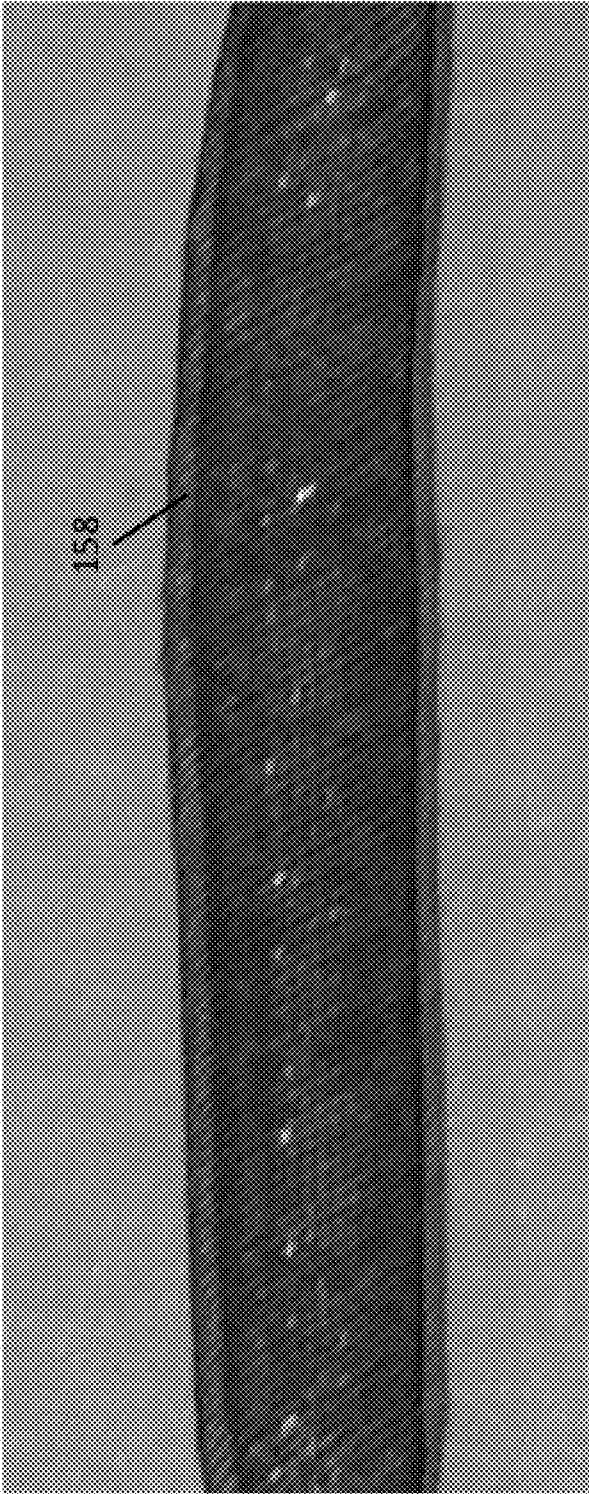


FIG. 10A



Fig. 10B

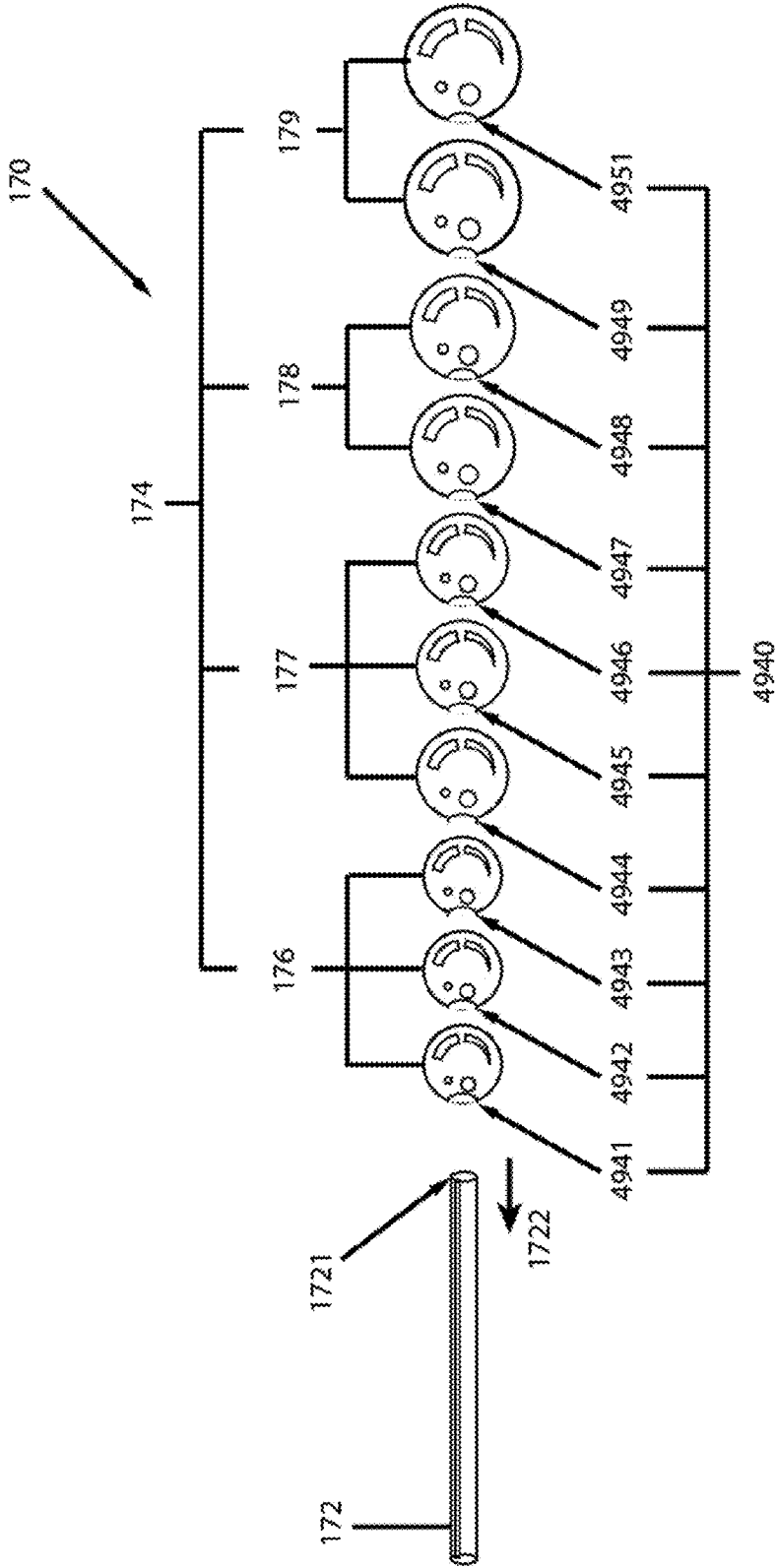


Fig. 10C

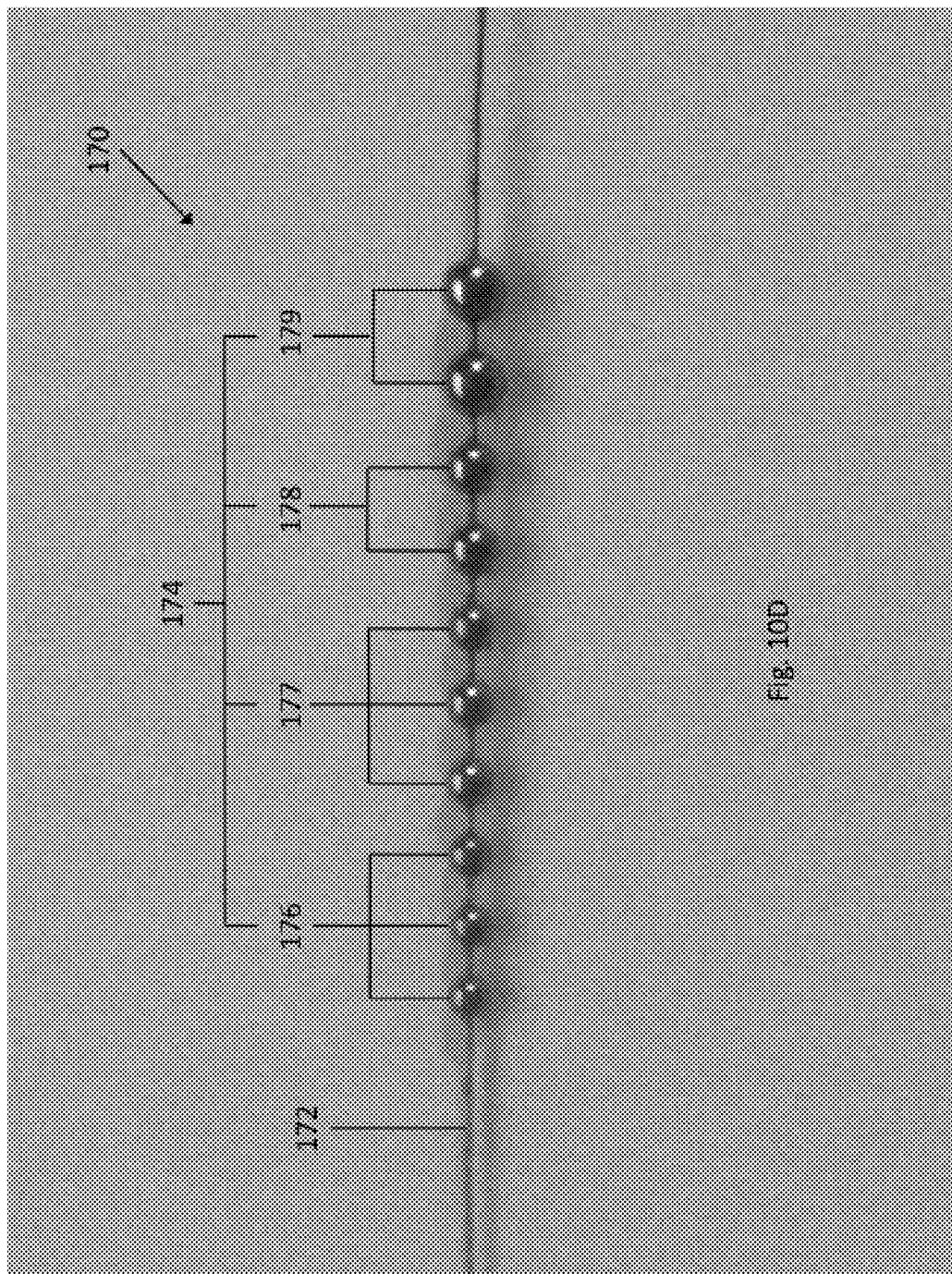


FIG. 10D

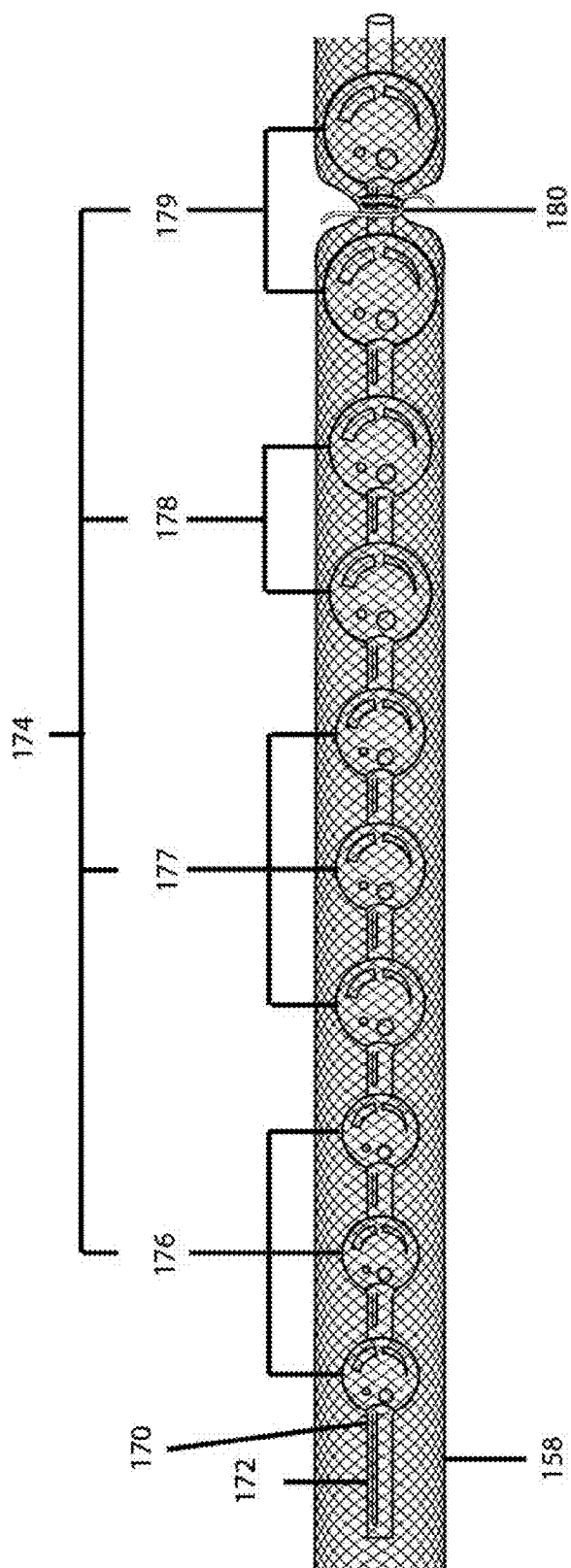


Fig. 10E



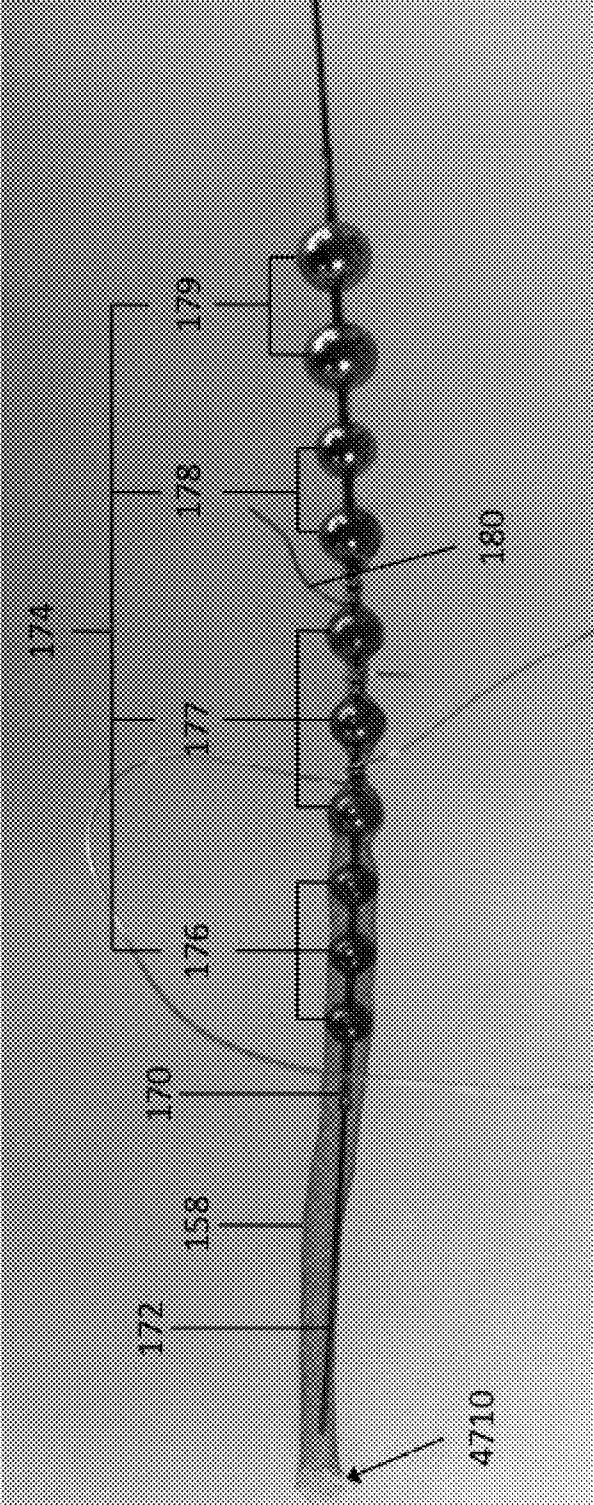


Fig. 10F

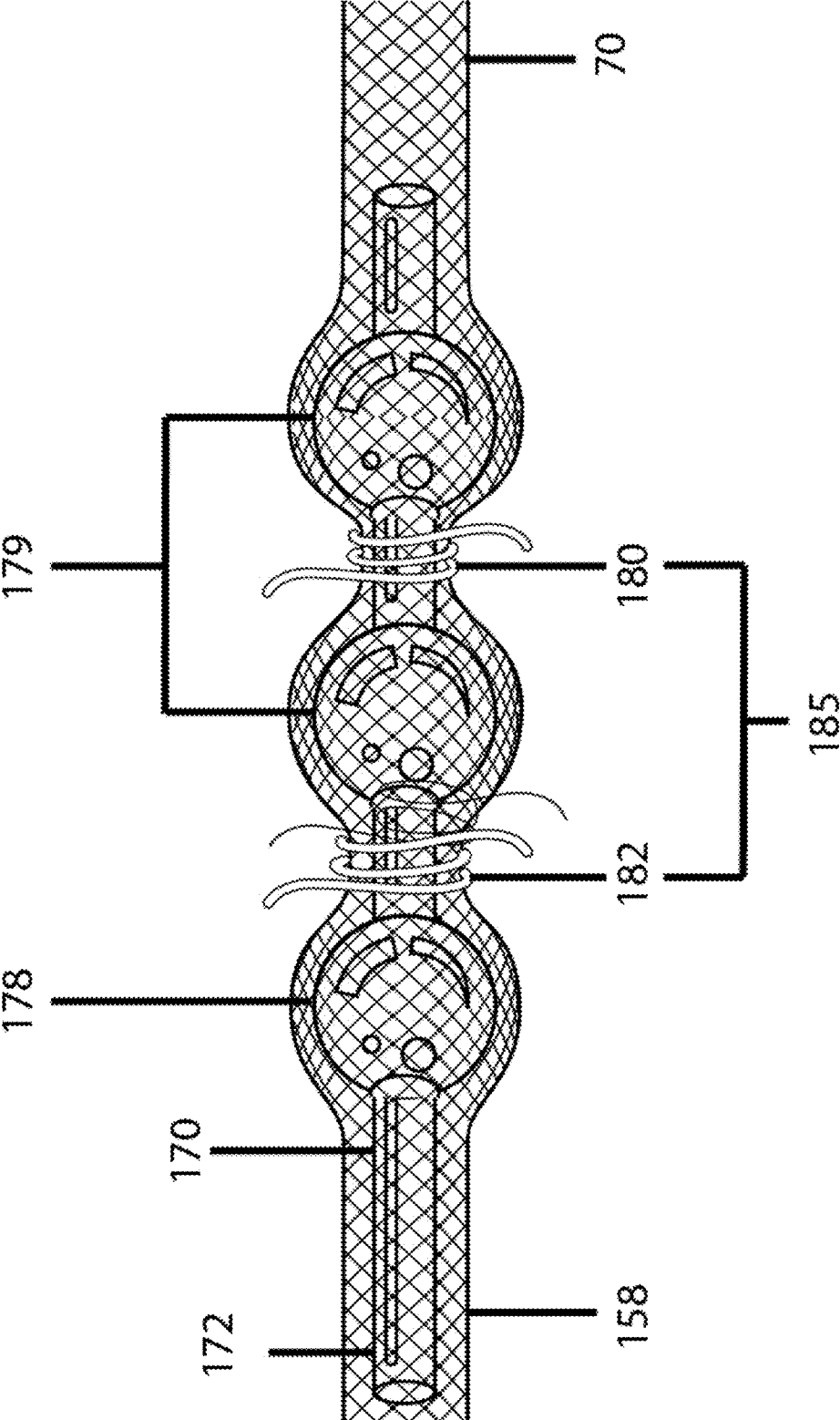


Fig. 10G

5100

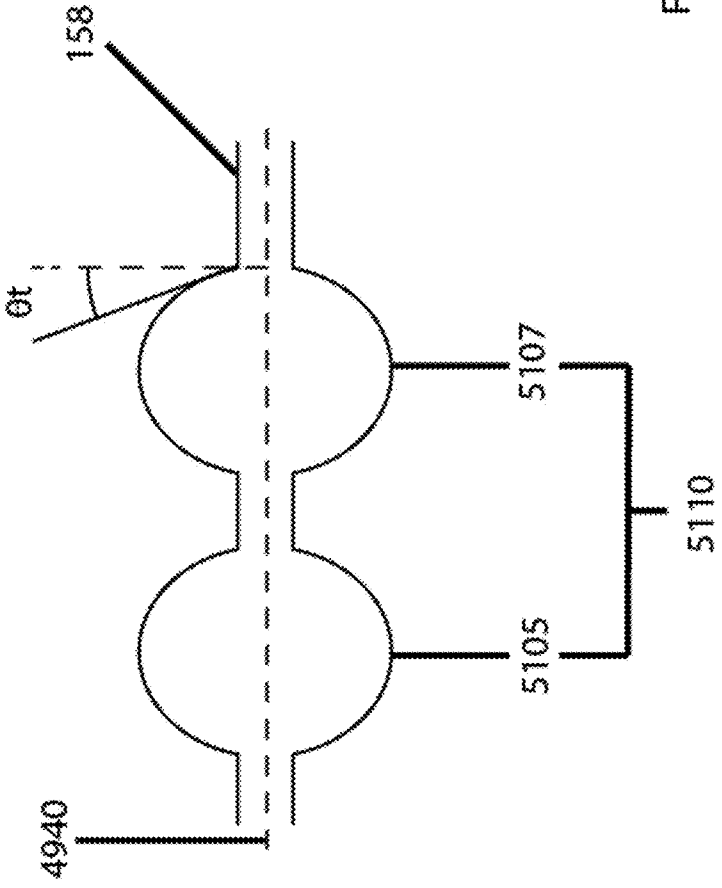


Fig. 10H

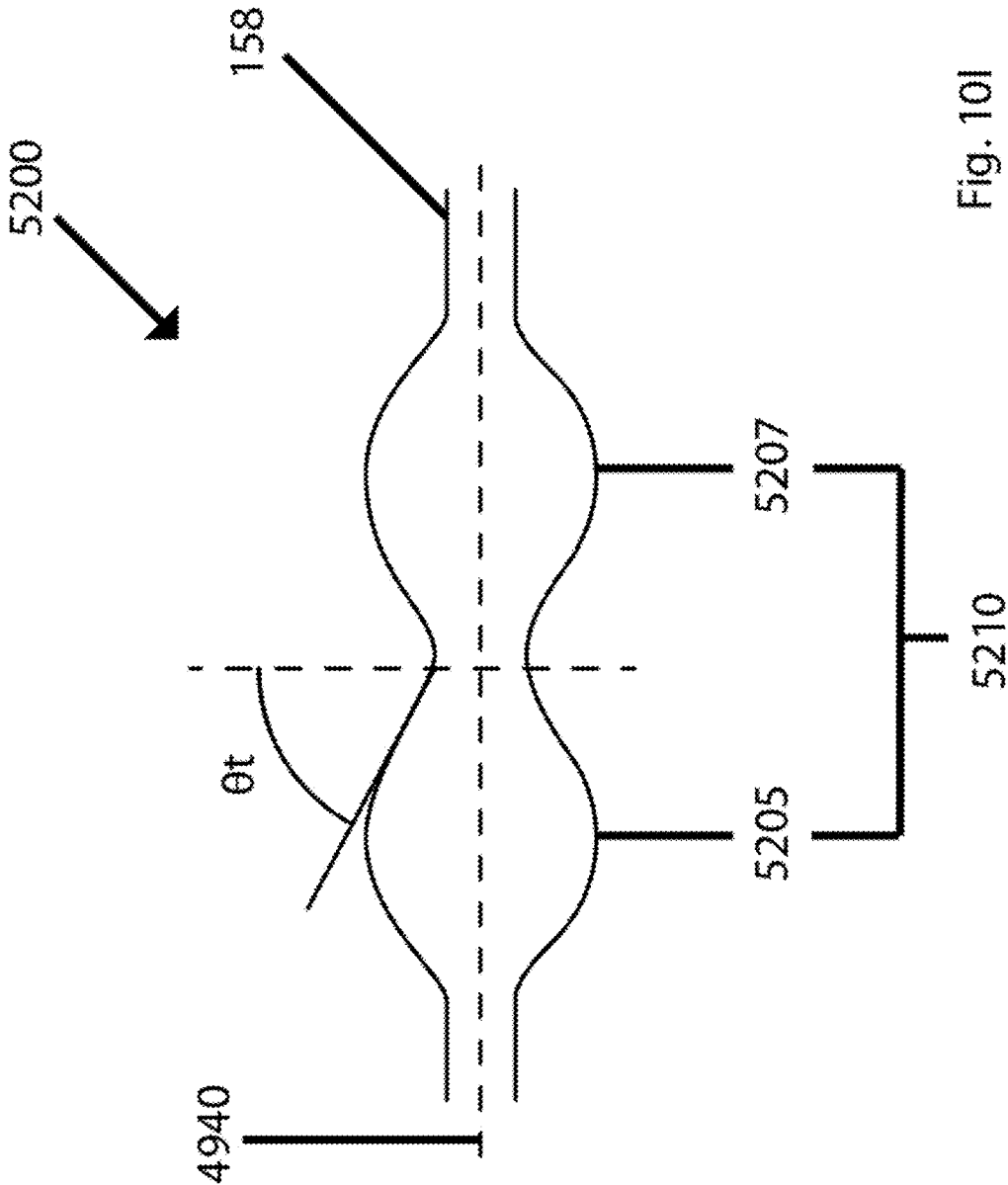


Fig. 10I

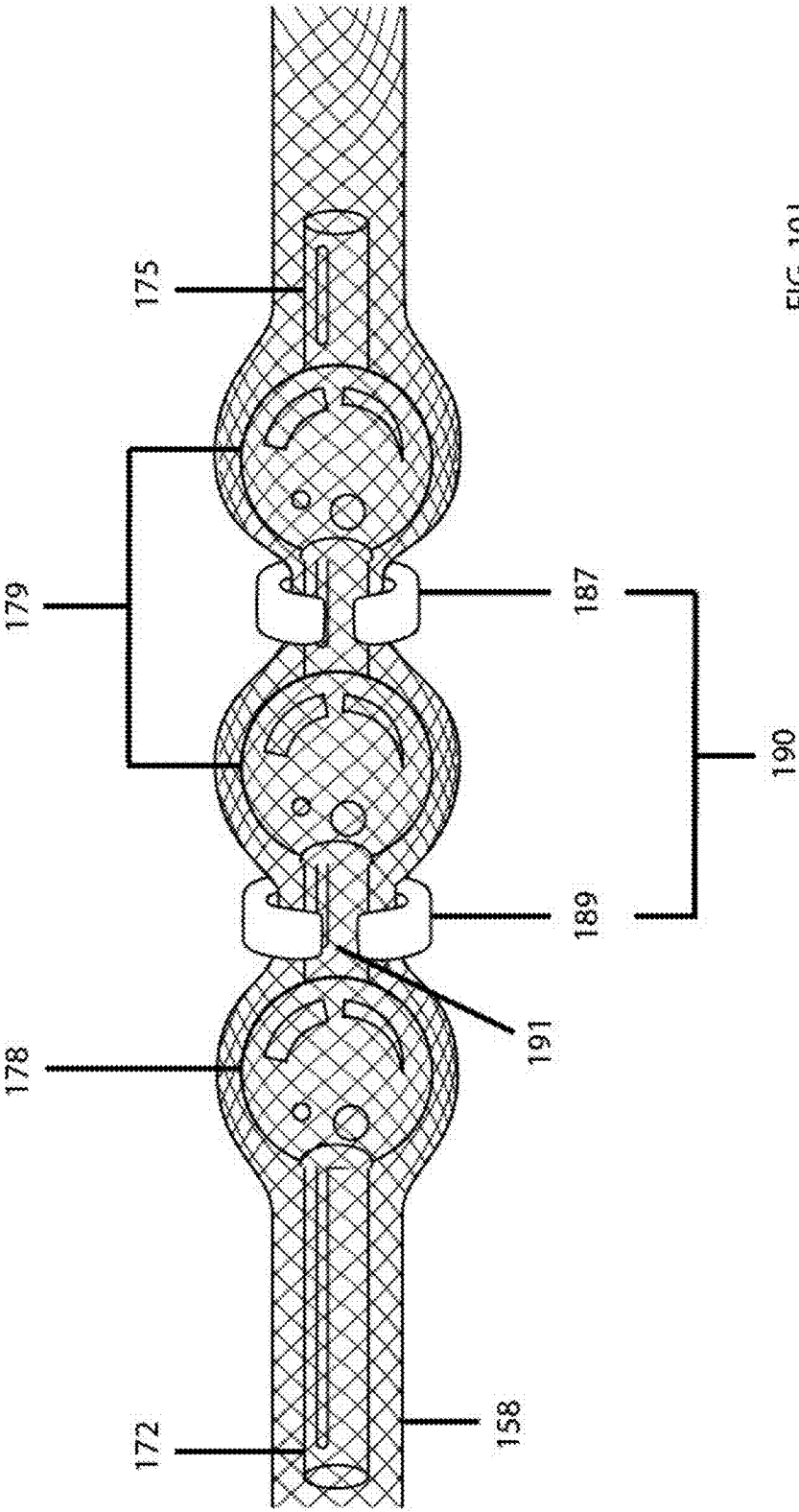


FIG. 10J

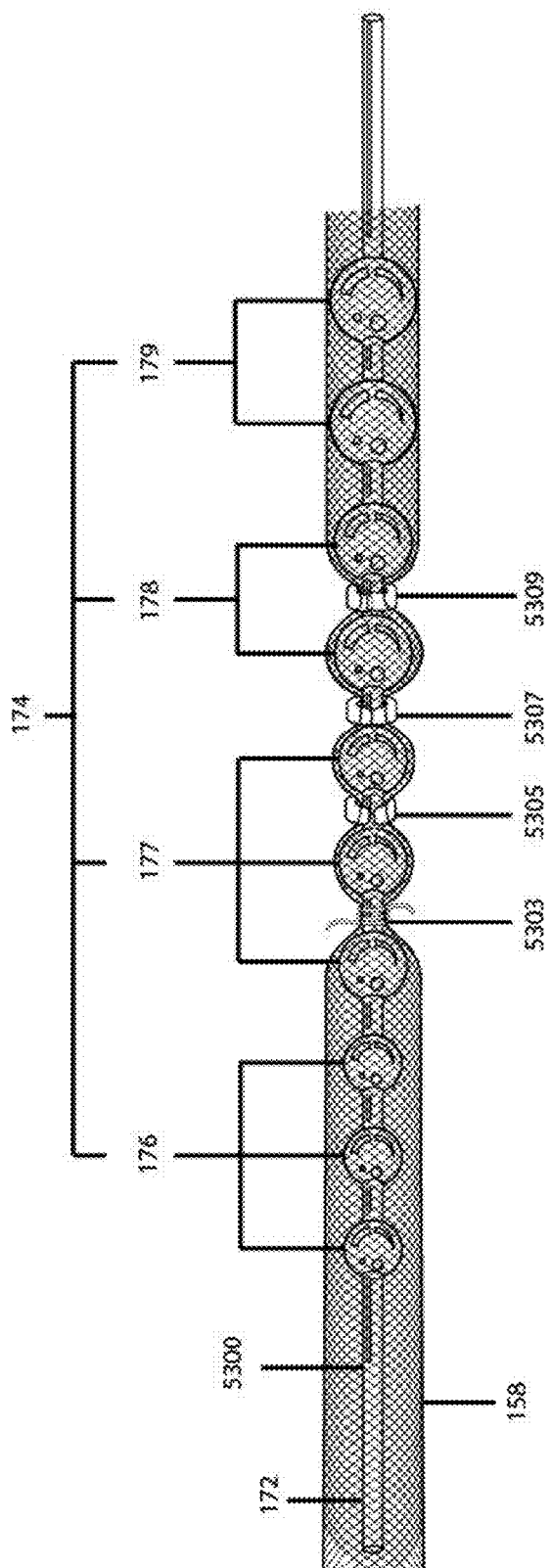


Fig. 10K

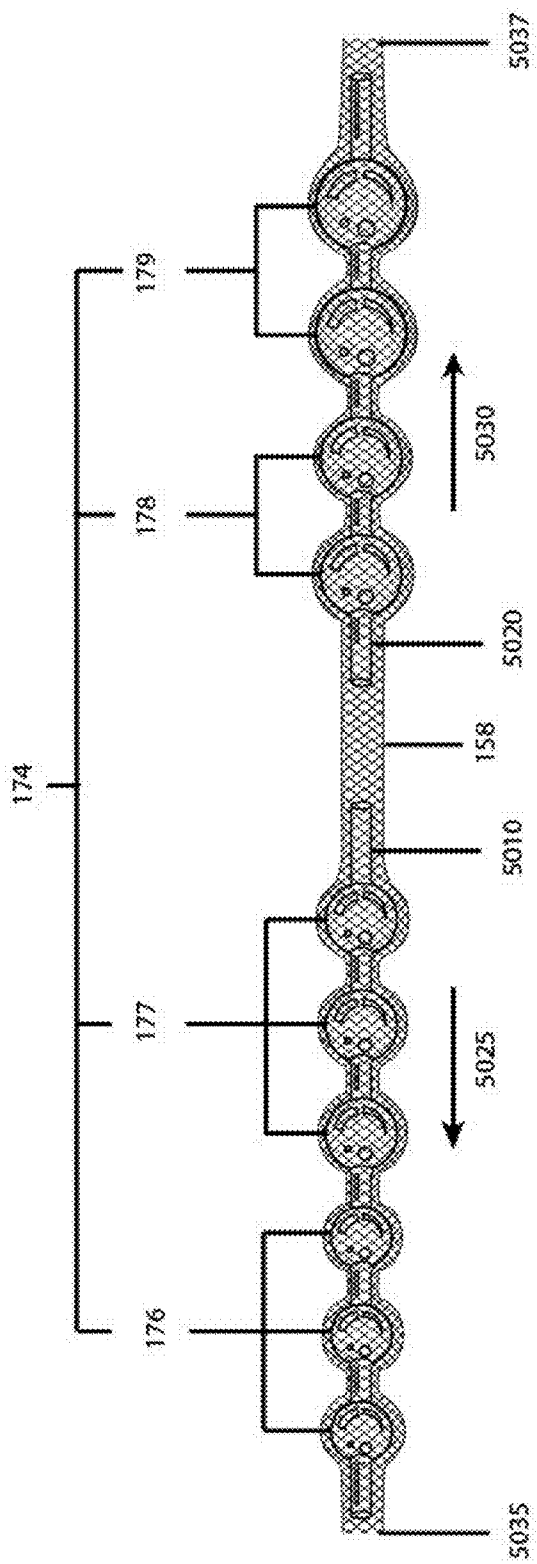


Fig. 10L

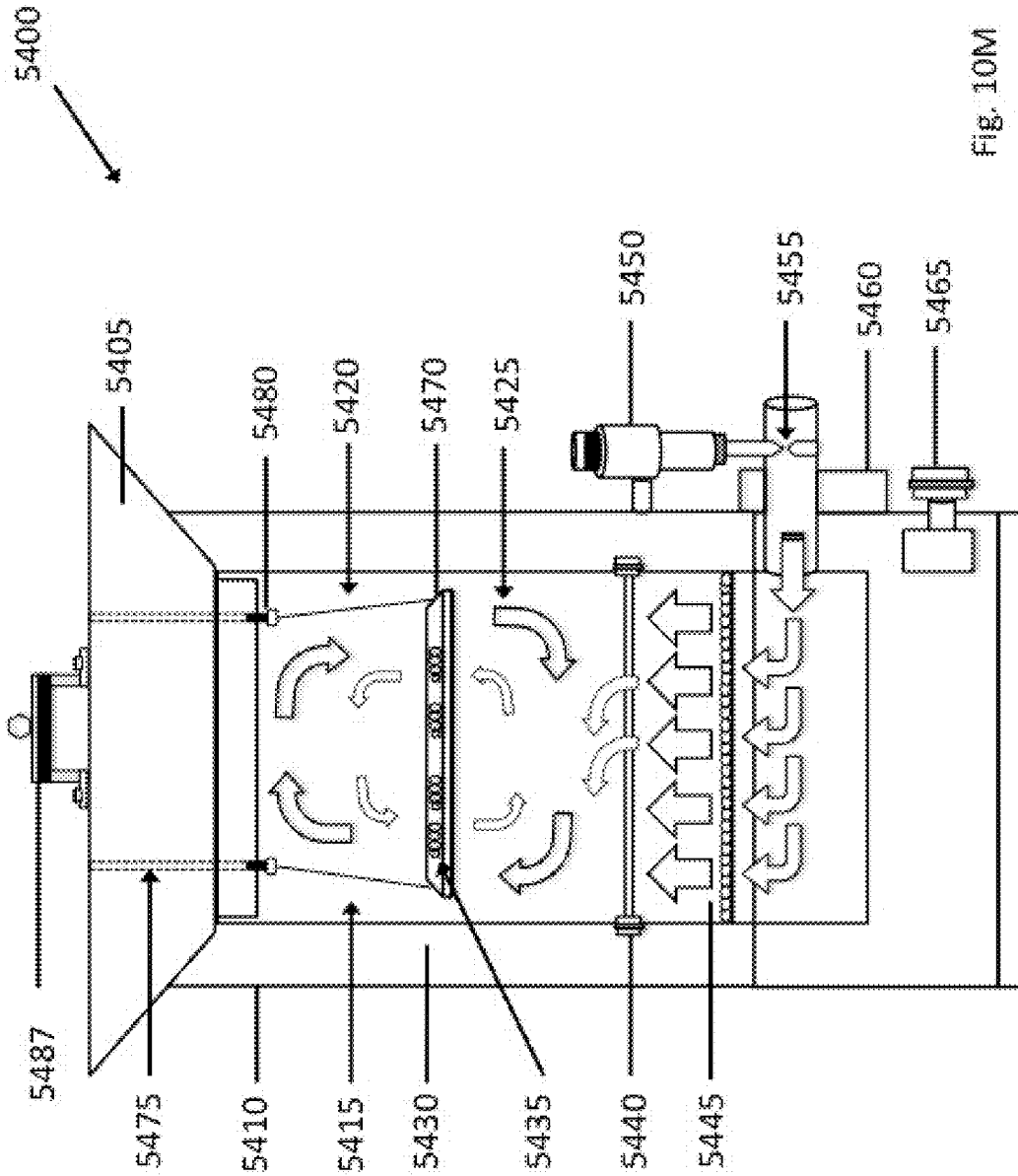


Fig. 10M



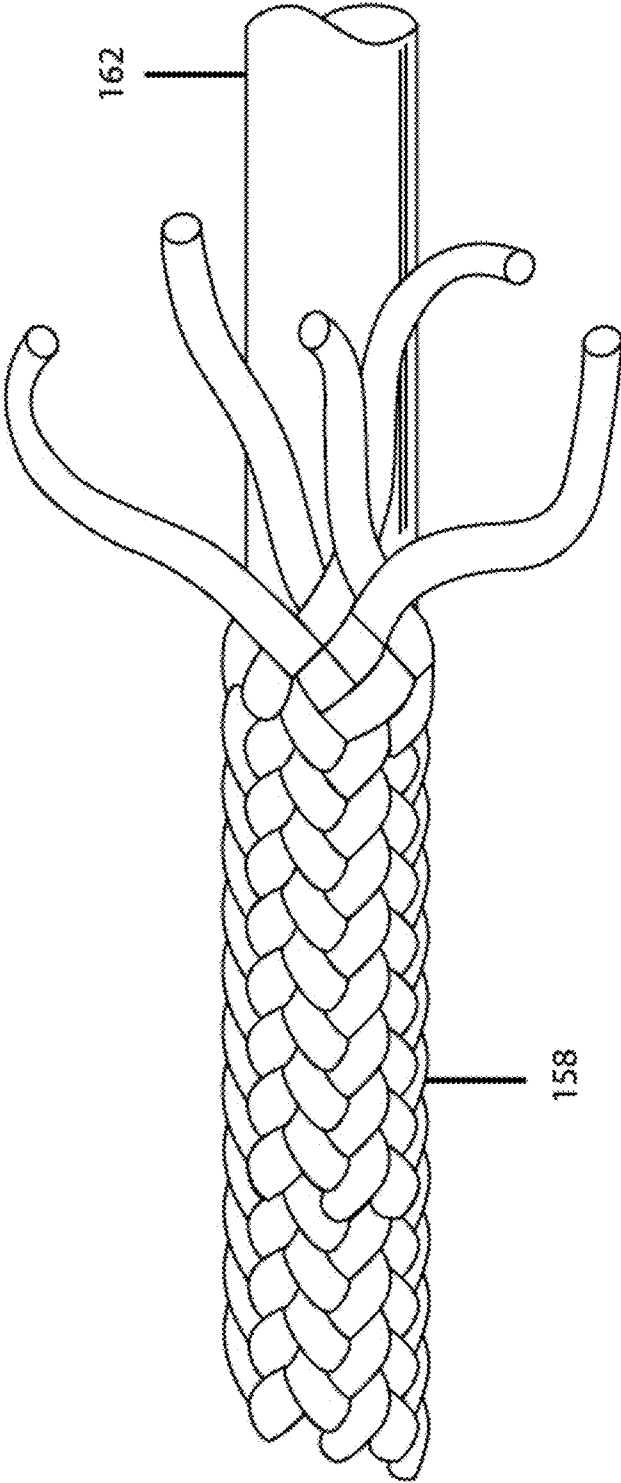


Fig. 11A

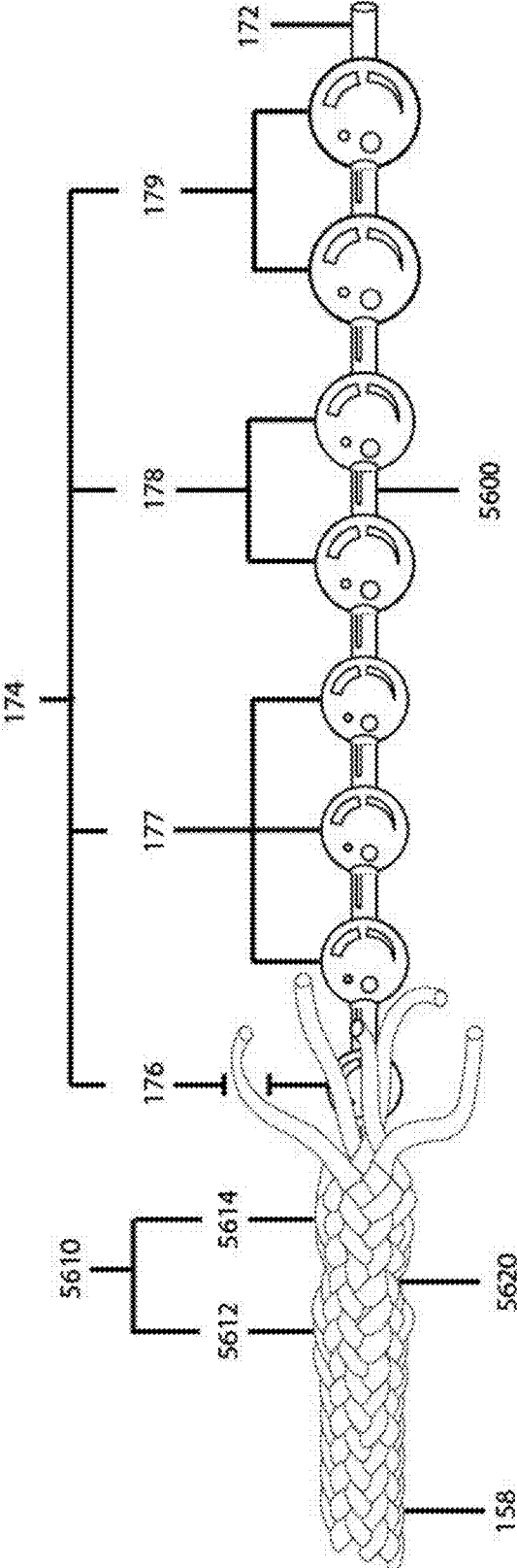


Fig. 11B

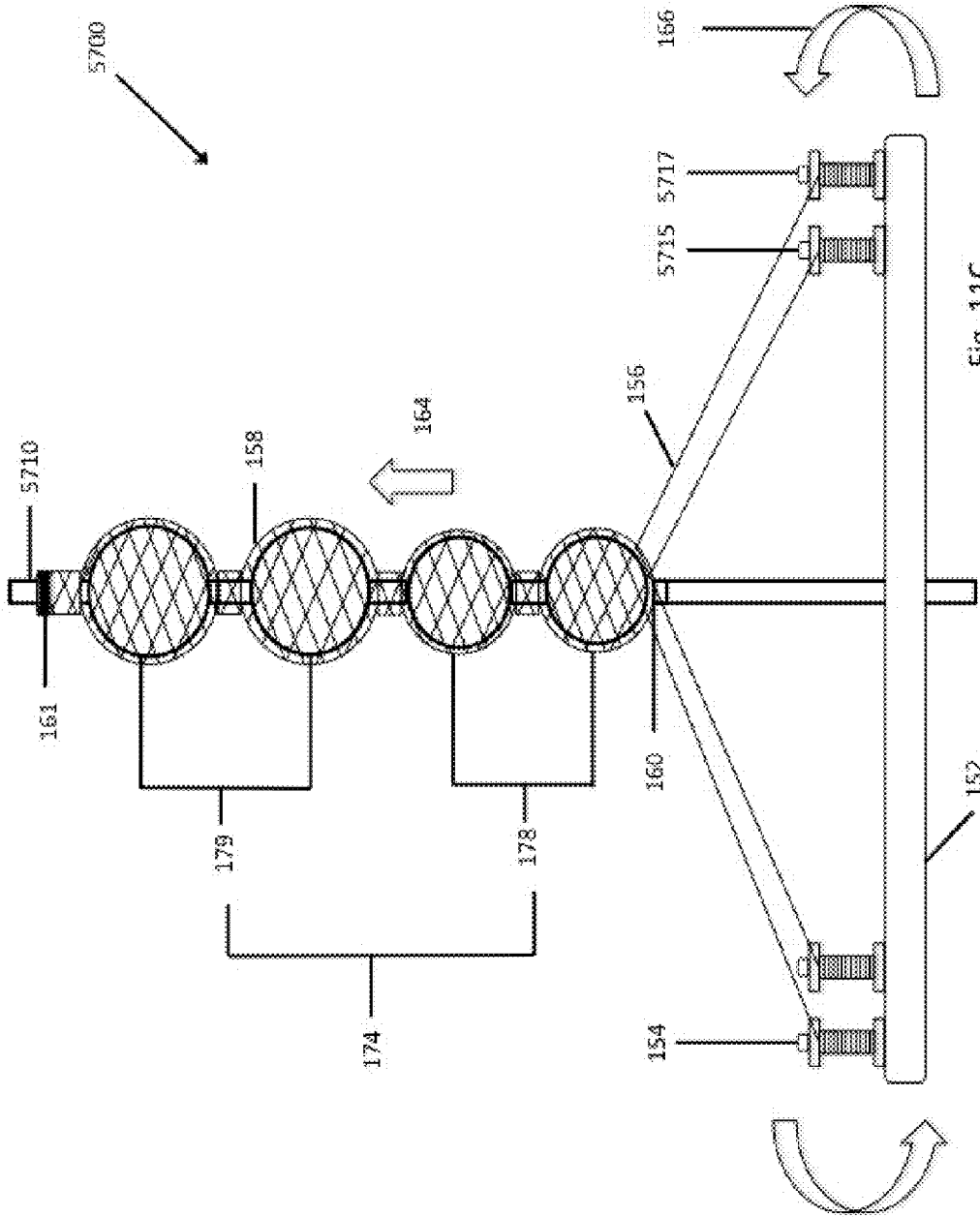


Fig. 11C

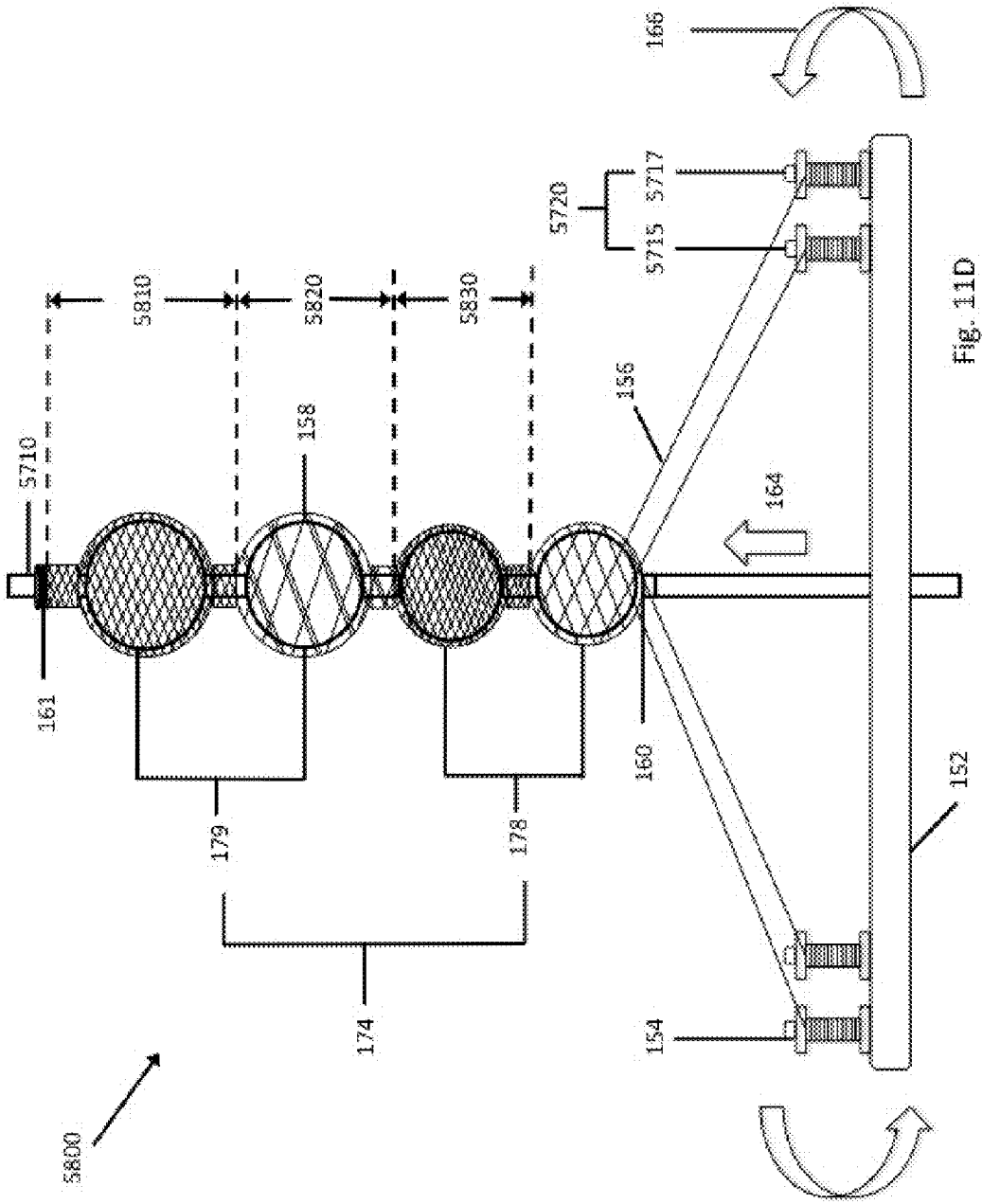


Fig. 11D

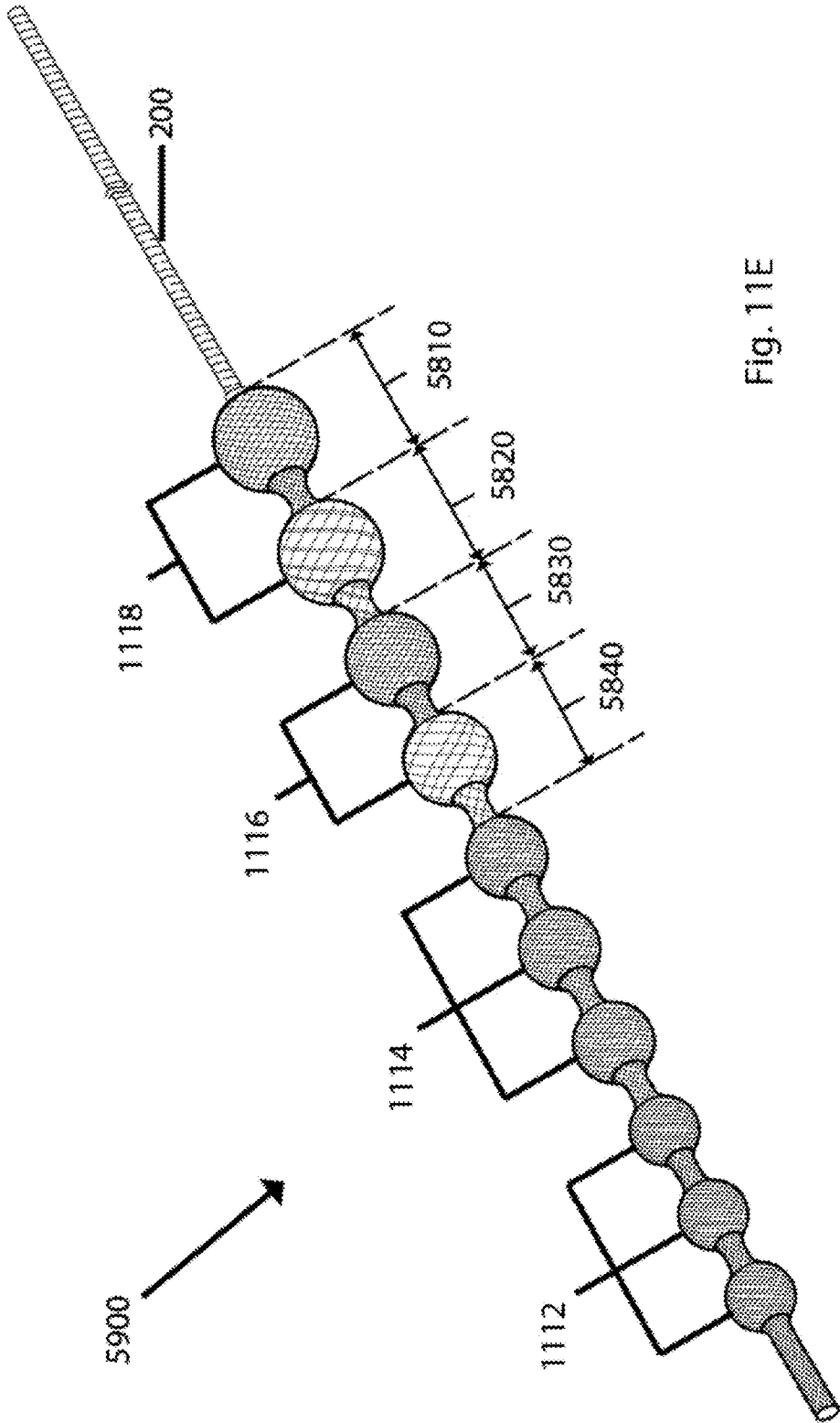


Fig. 11E

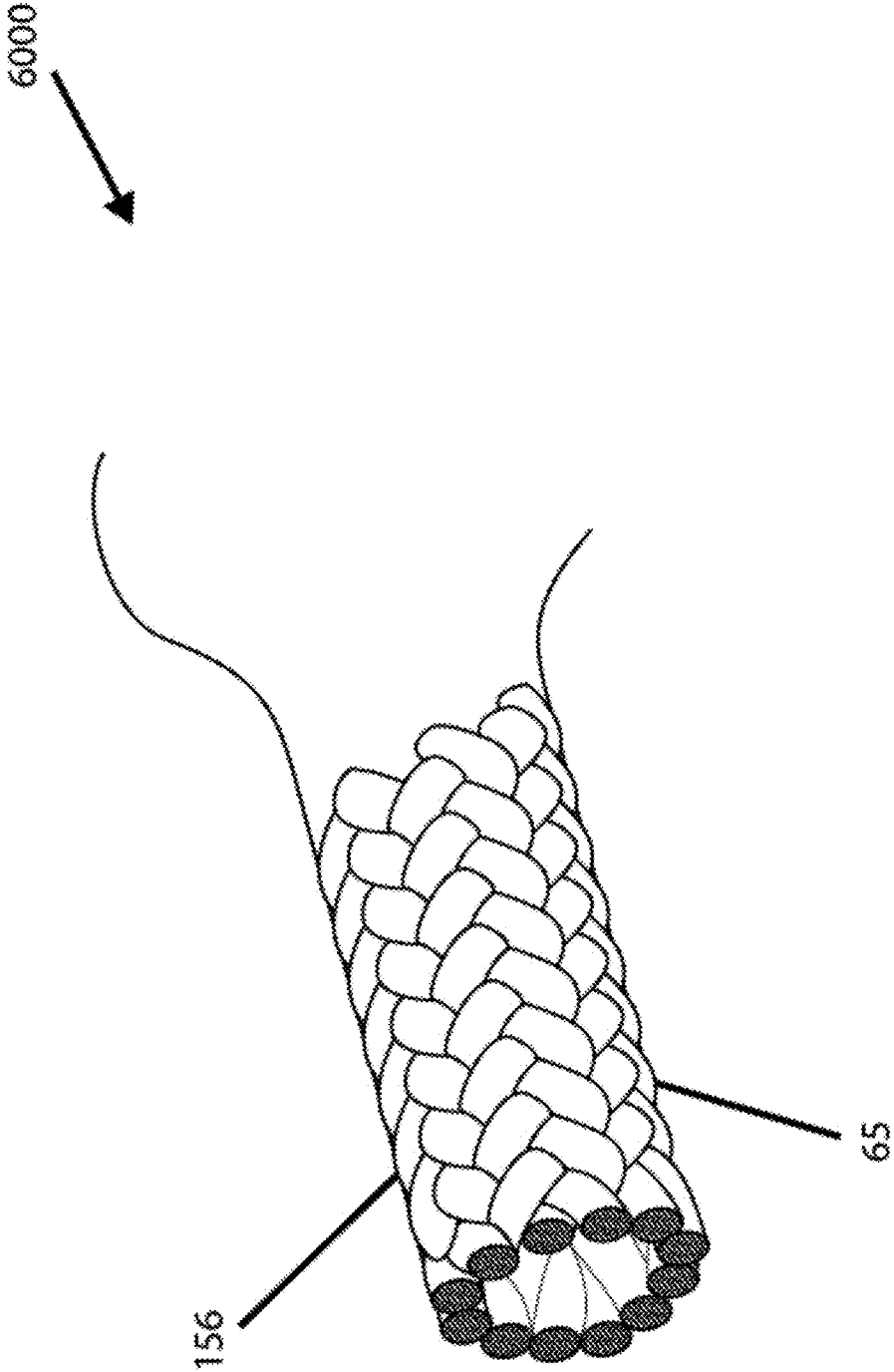


Fig. 12A

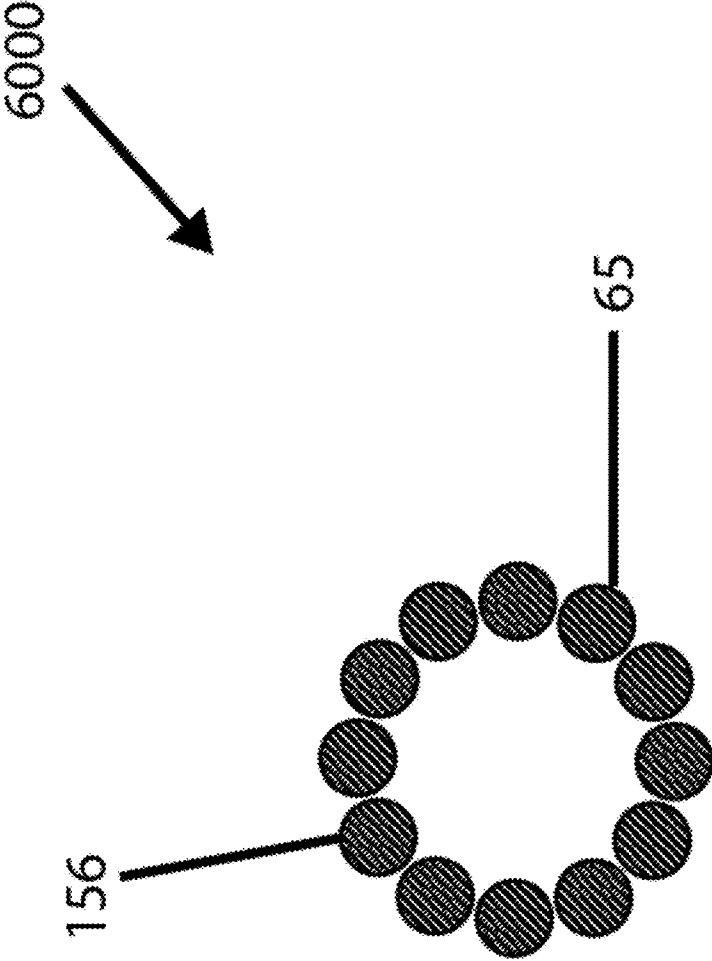


Fig. 12B

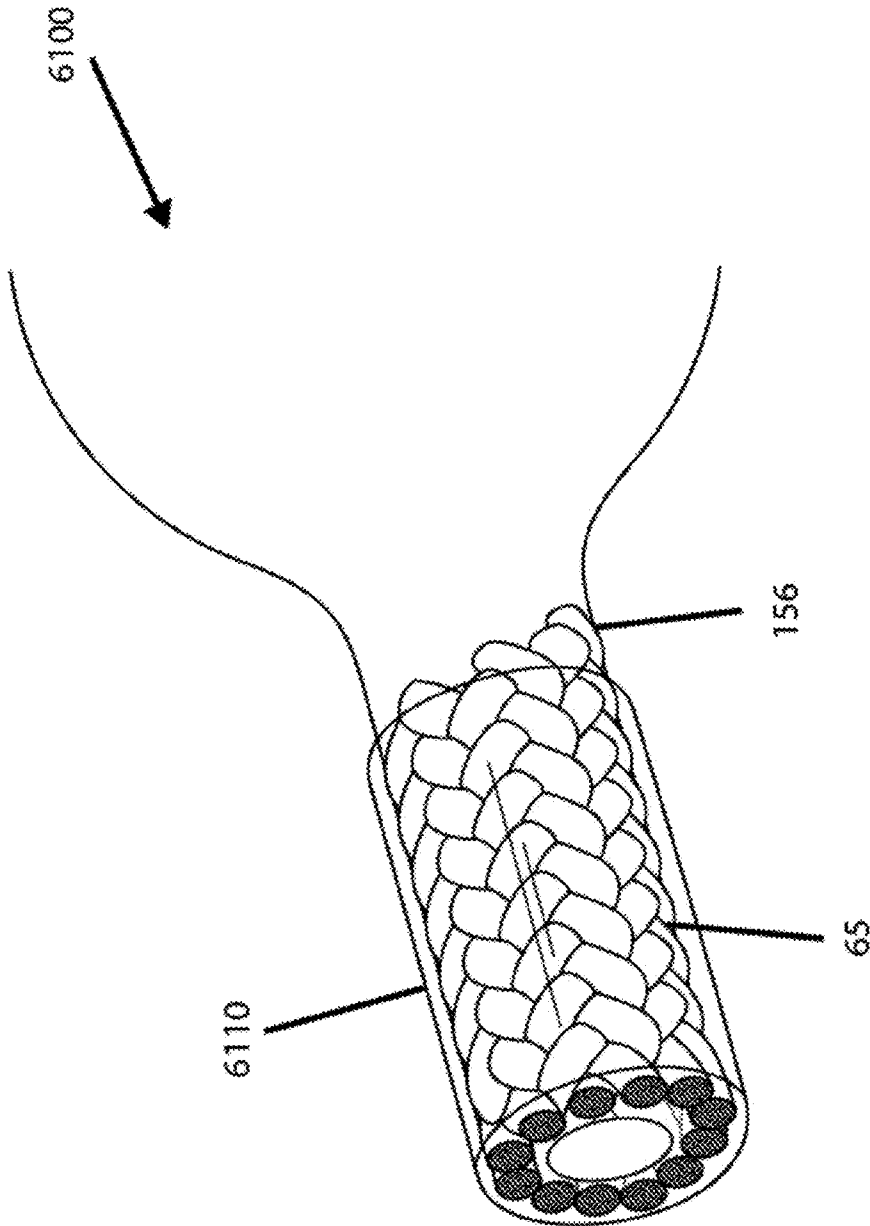


Fig. 12C



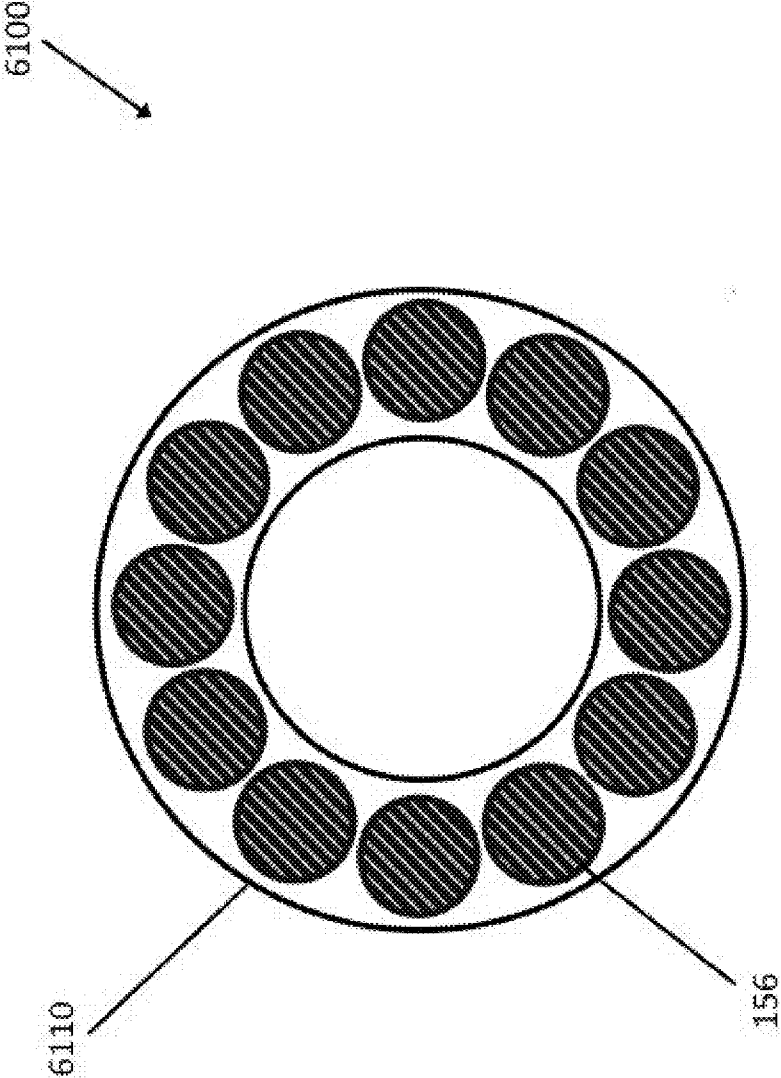


FIG. 12D

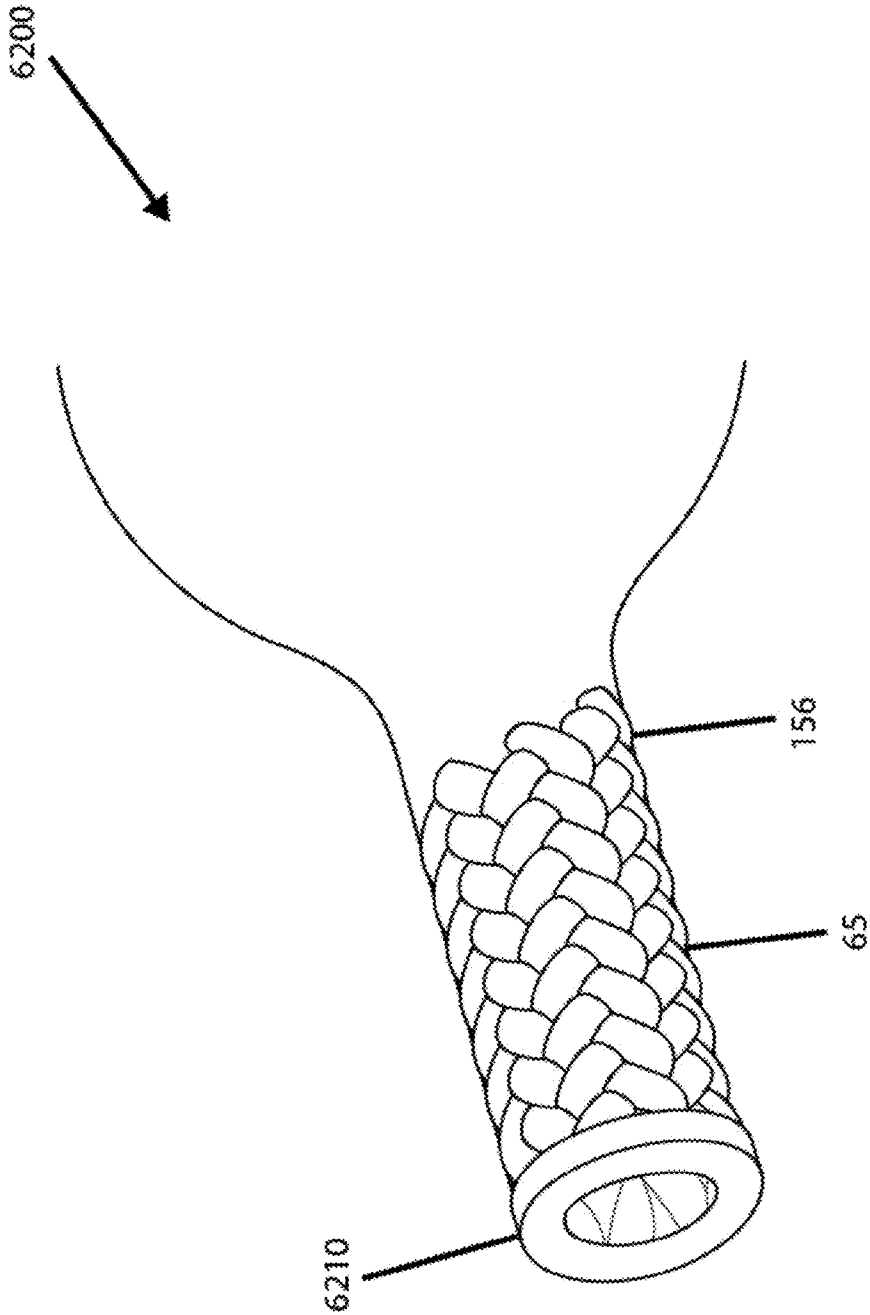


Fig. 12E

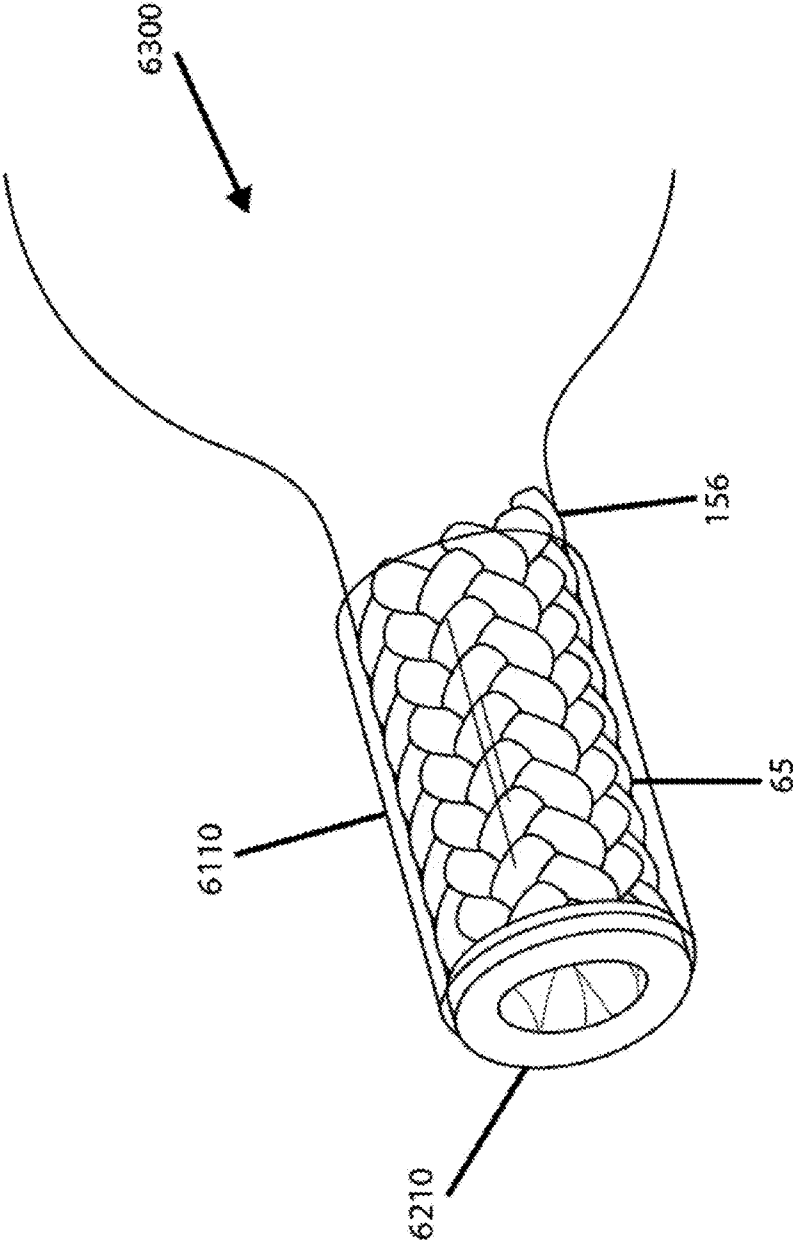


Fig. 12F

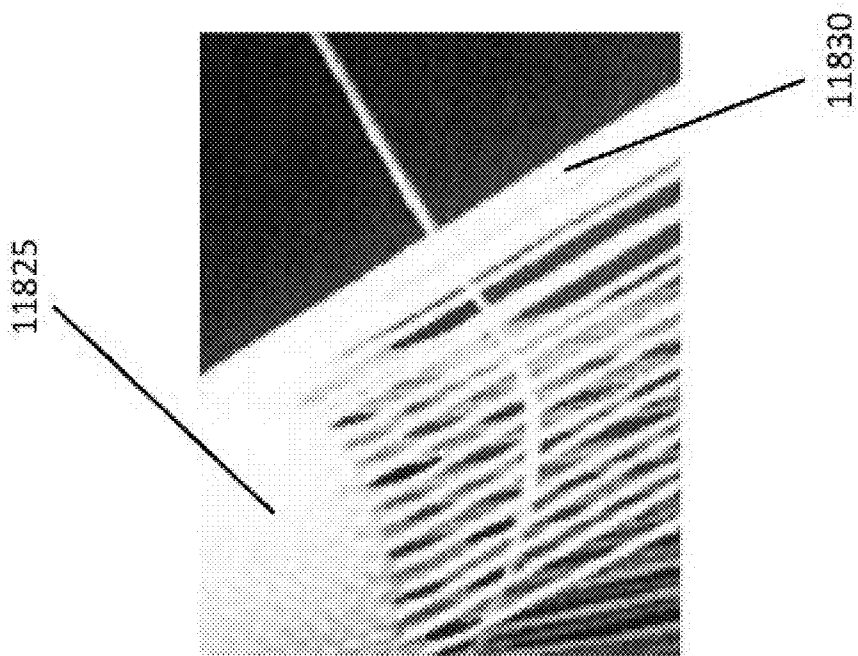


FIG. 13A

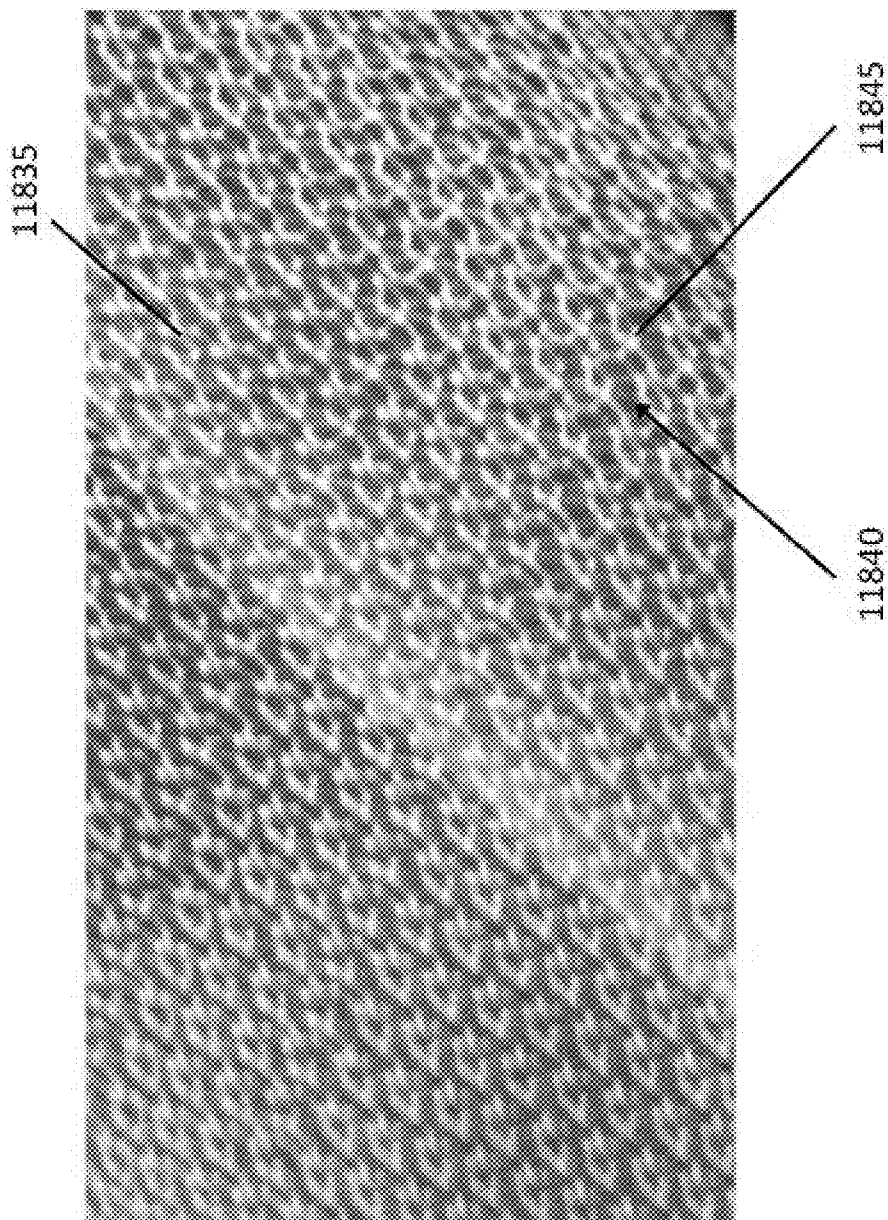


Fig. 13B

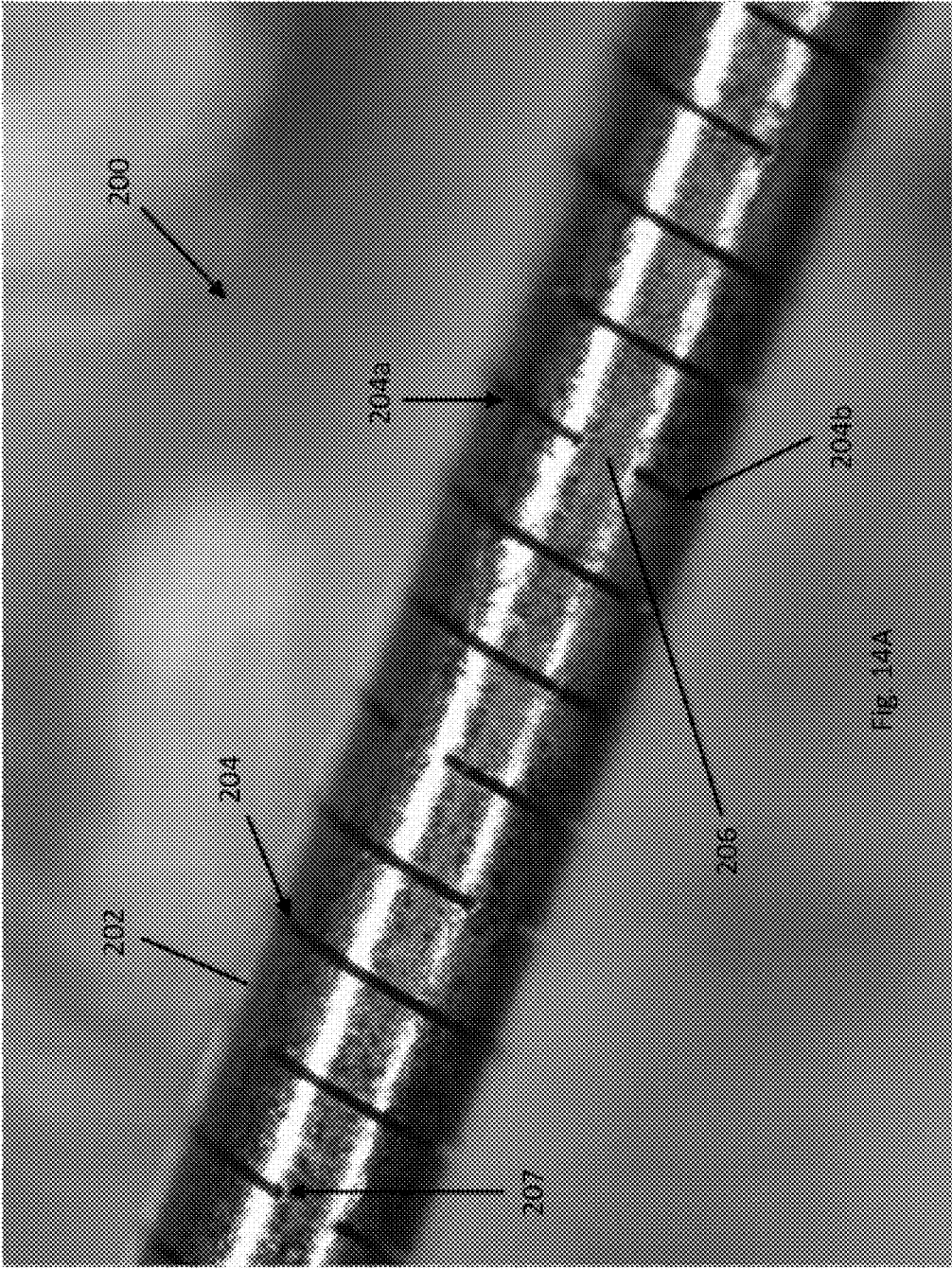
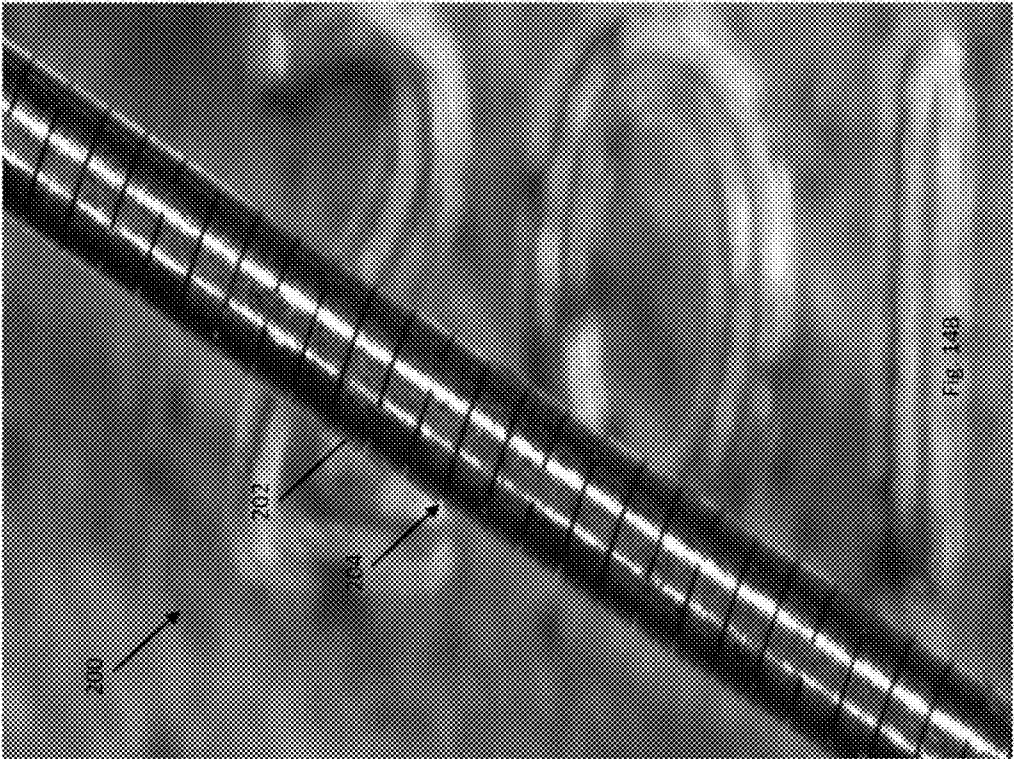


FIG. 14A



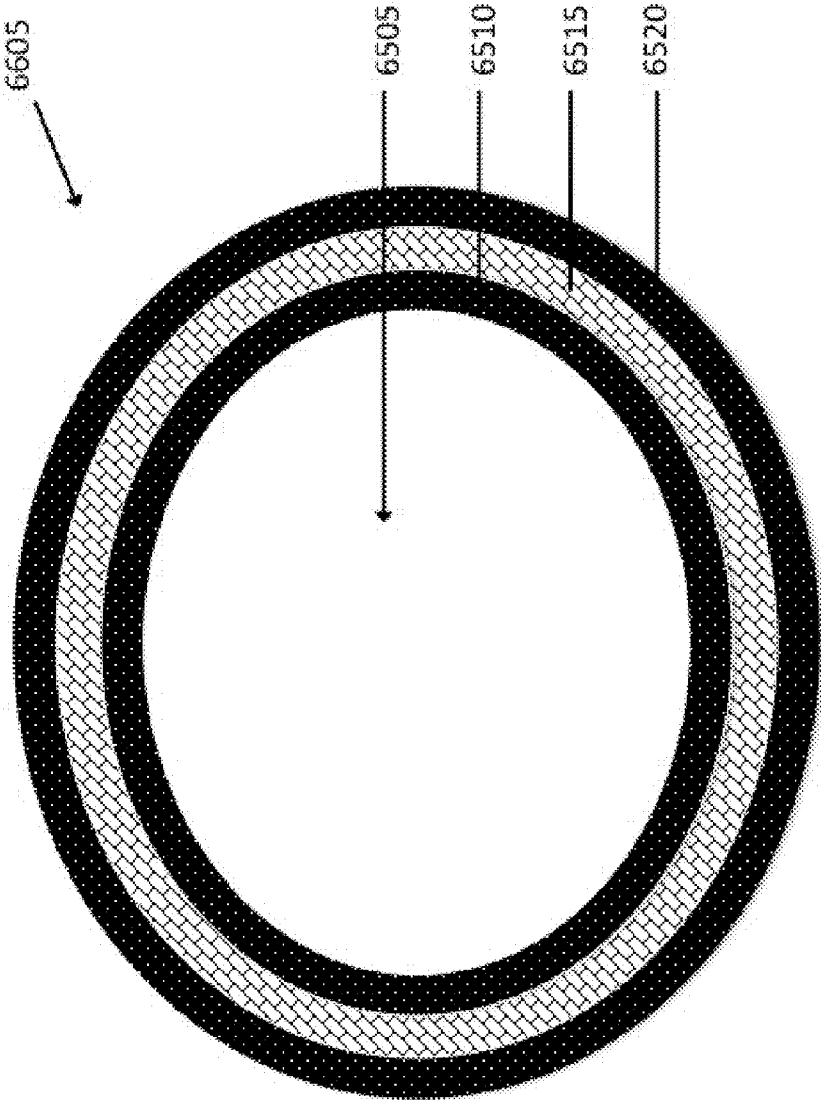


Fig. 14C



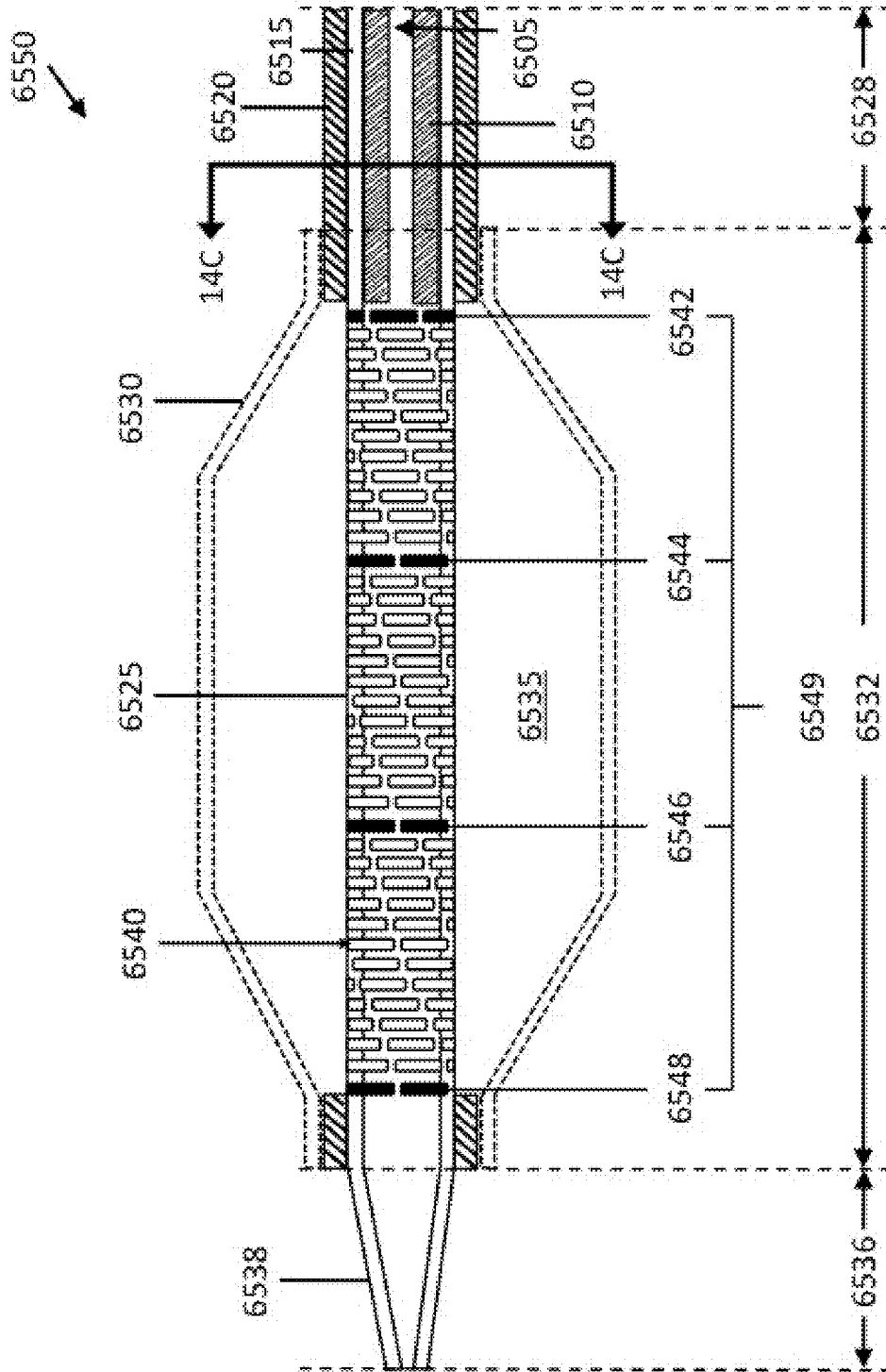


Fig. 14D

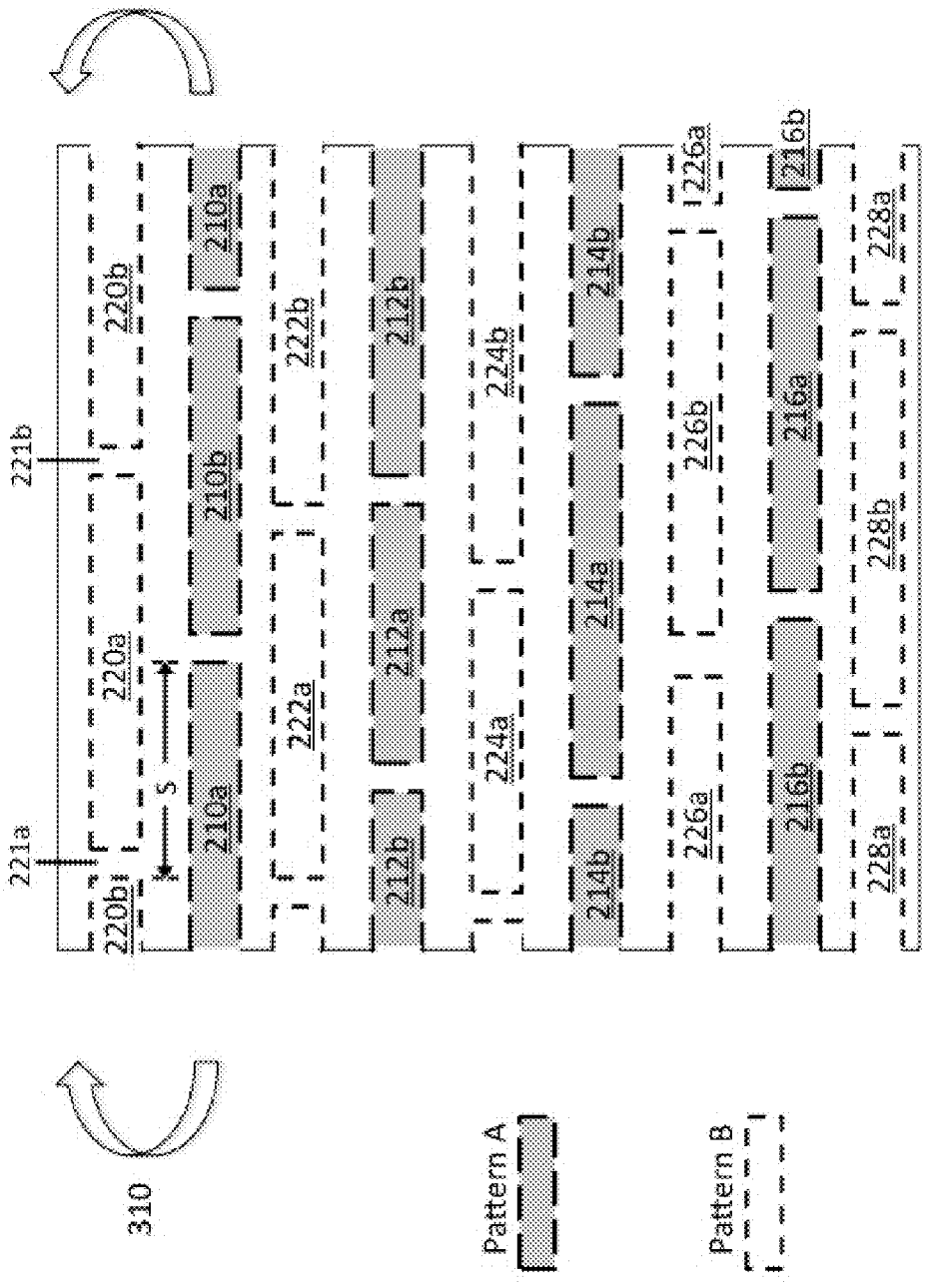


Fig. 15A

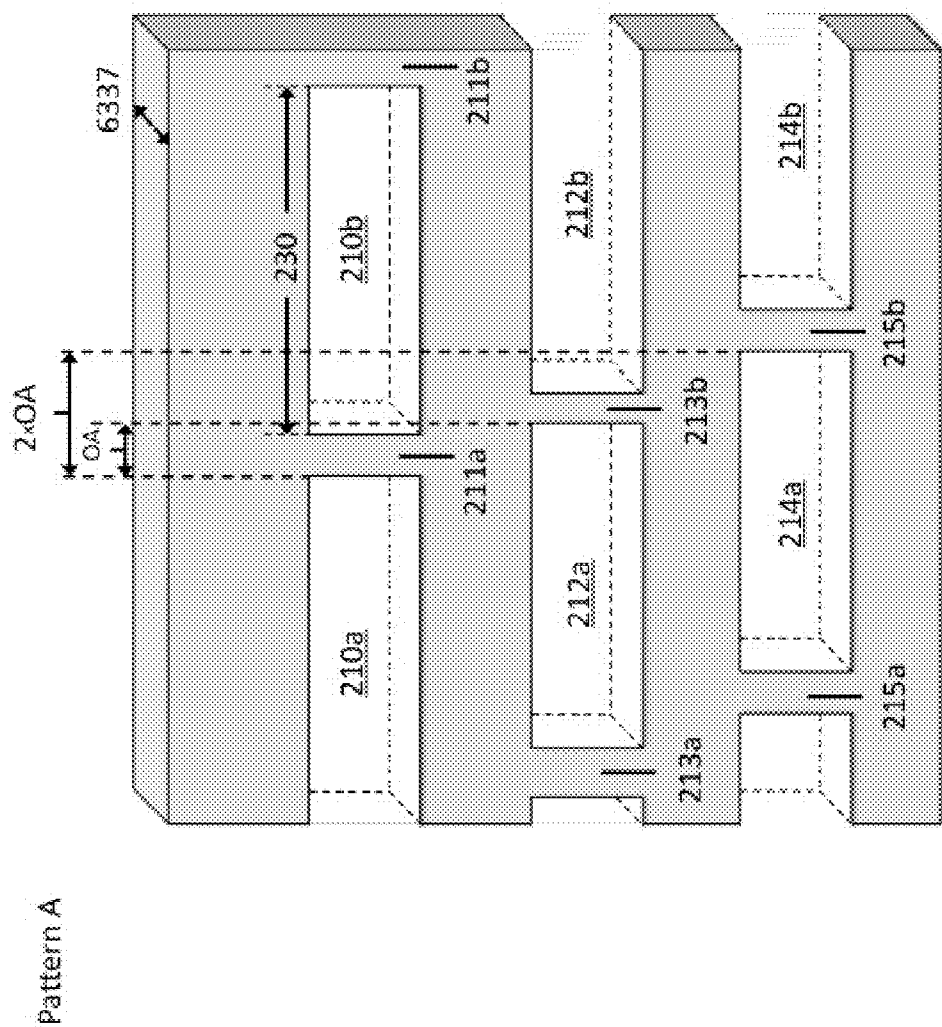


Fig. 15B



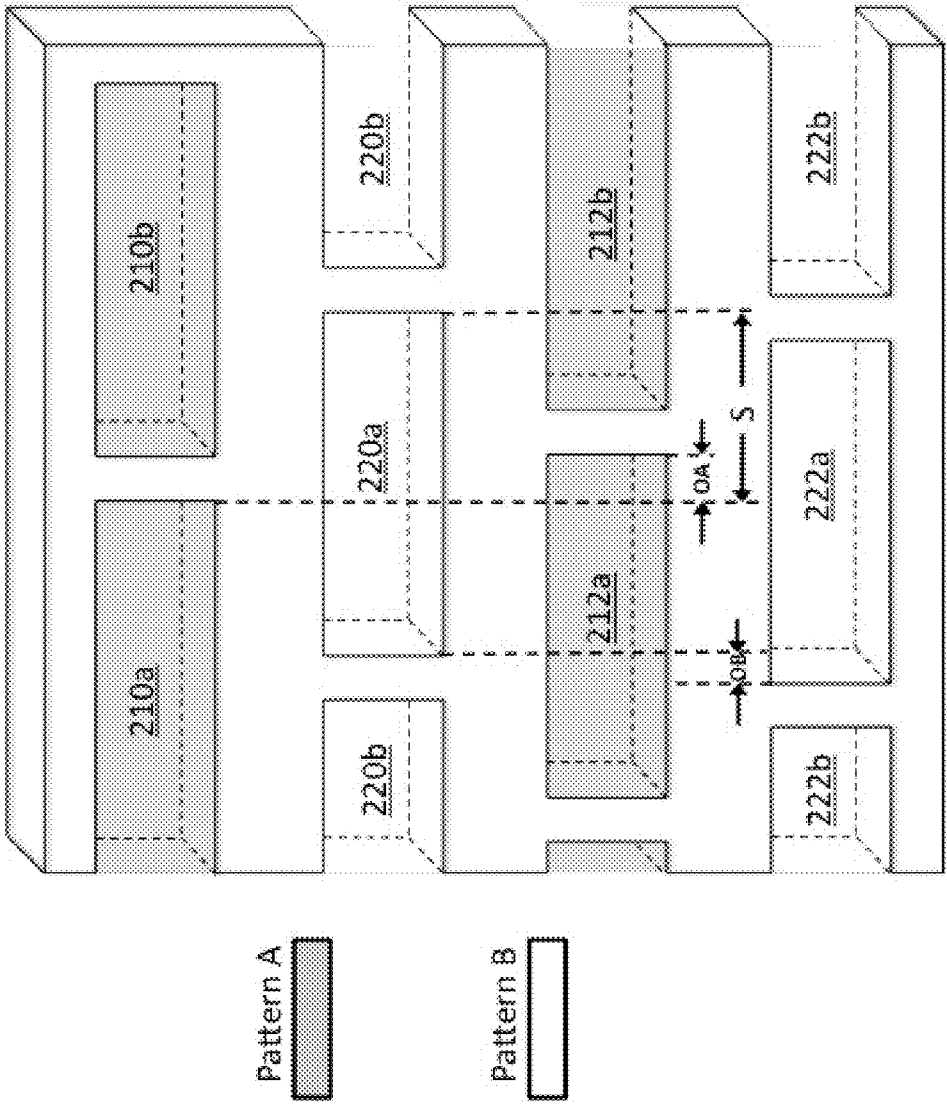


Fig. 15D

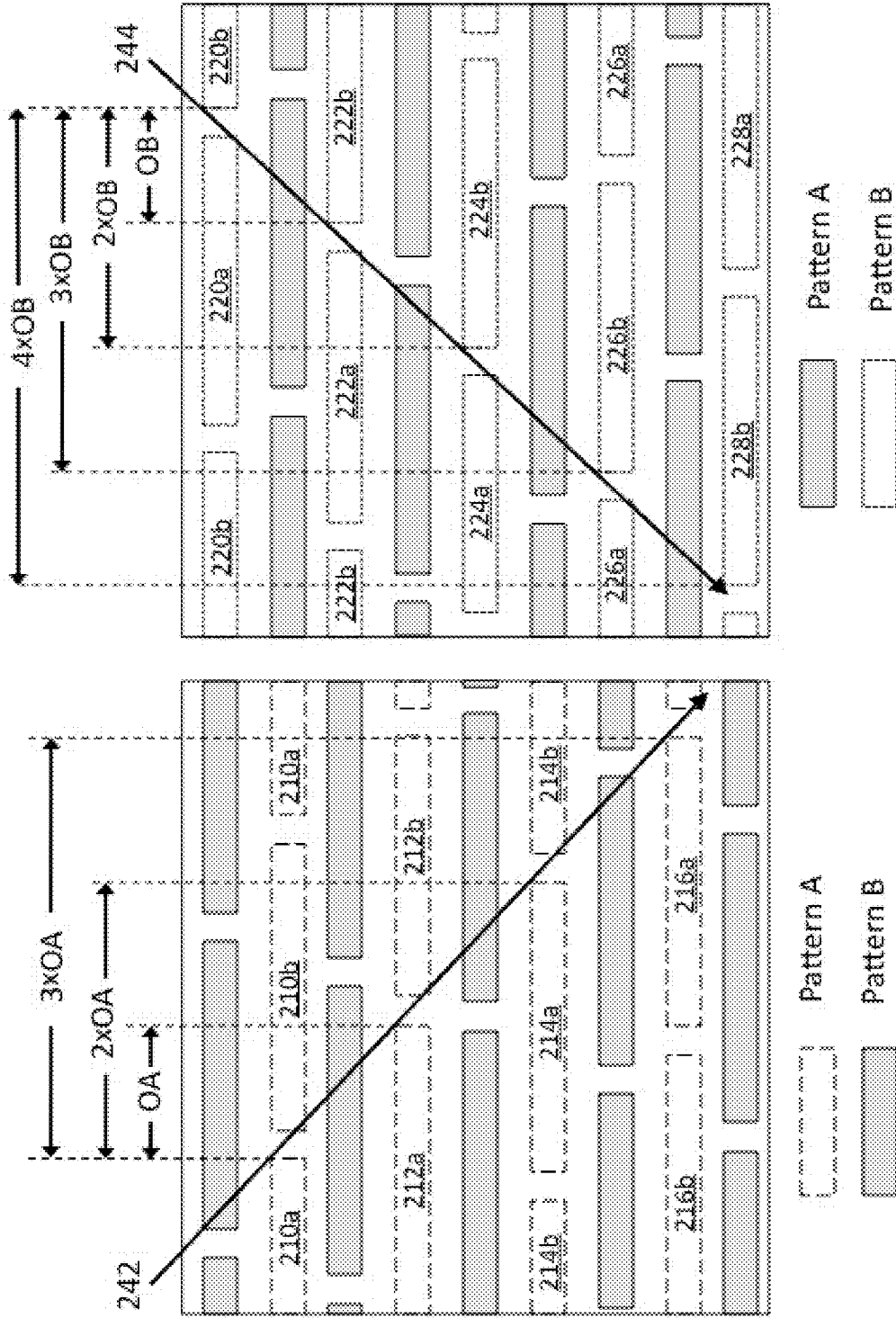


Fig. 15E

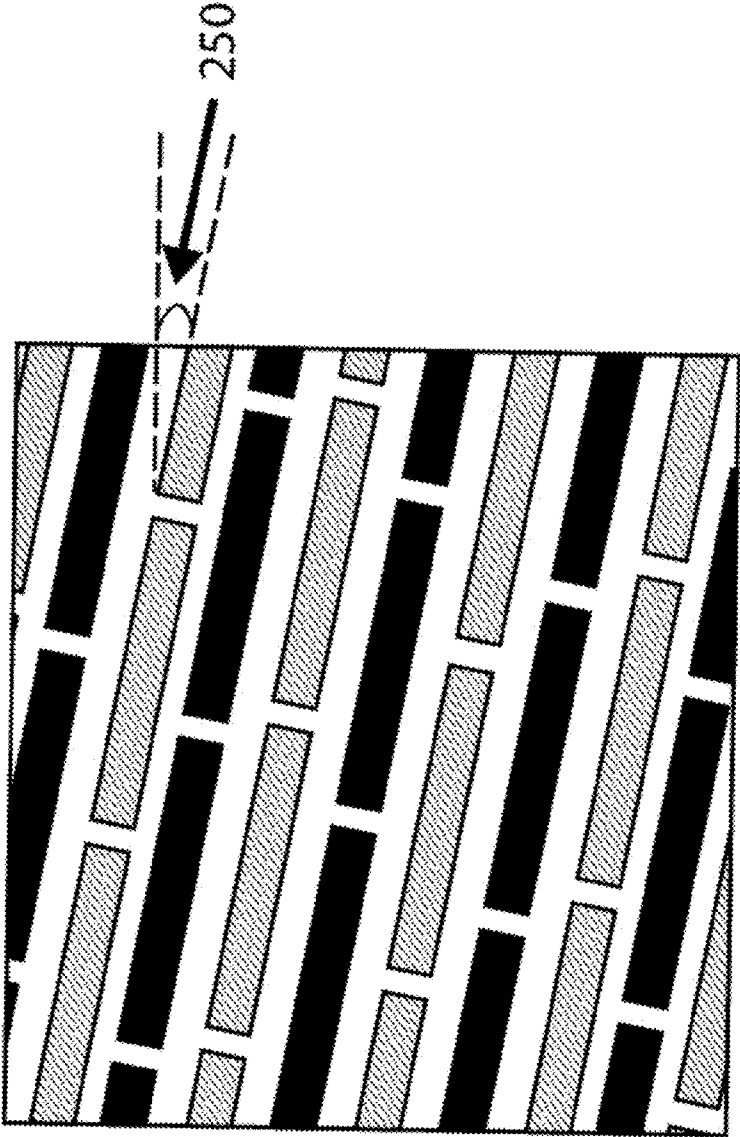


Fig. 16A

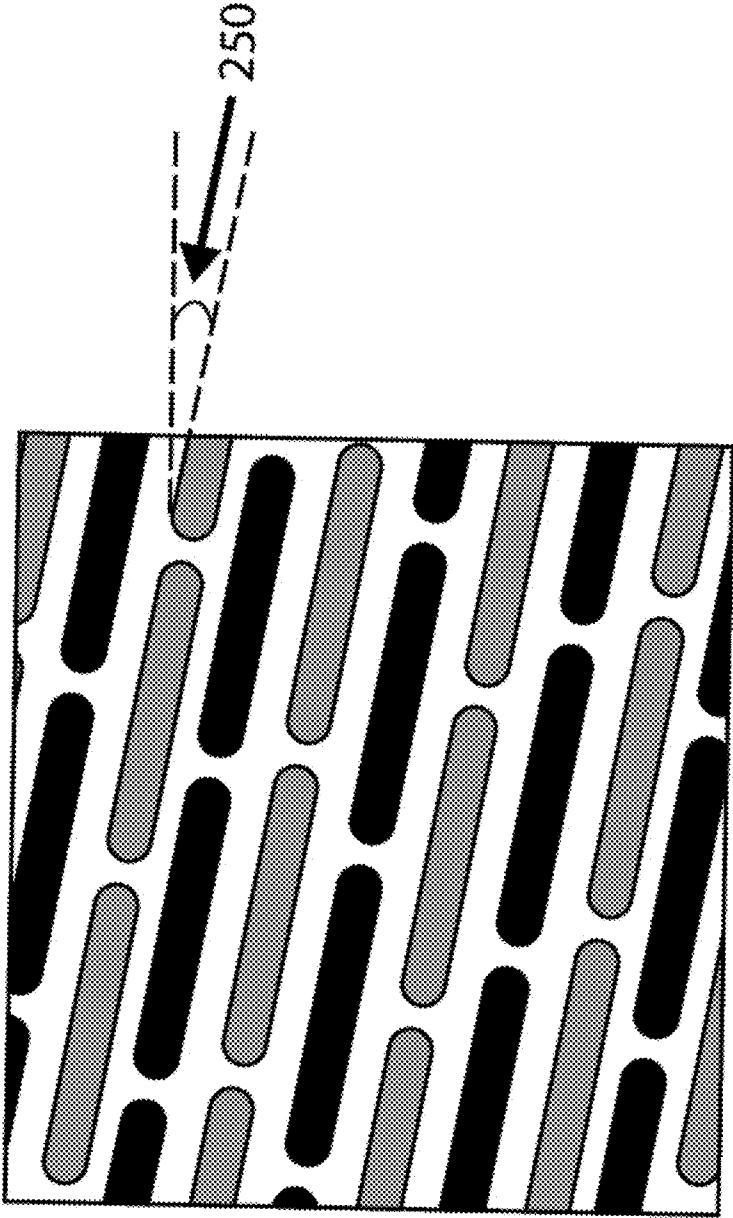


Fig. 16B



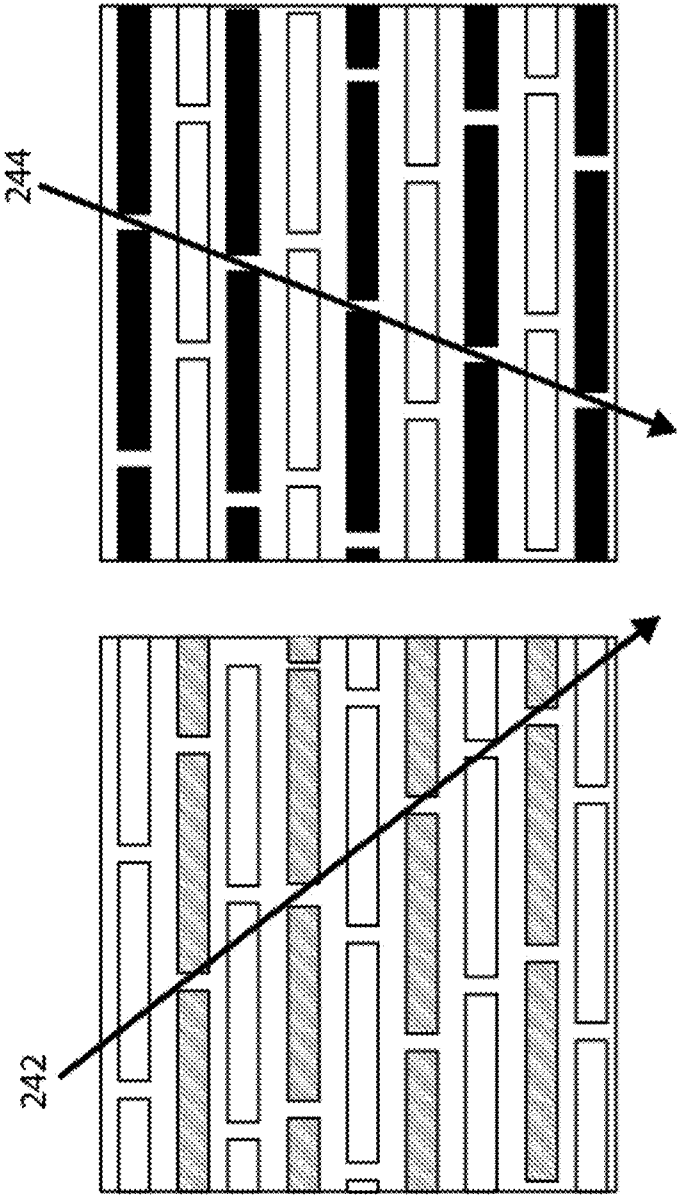


Fig. 16C

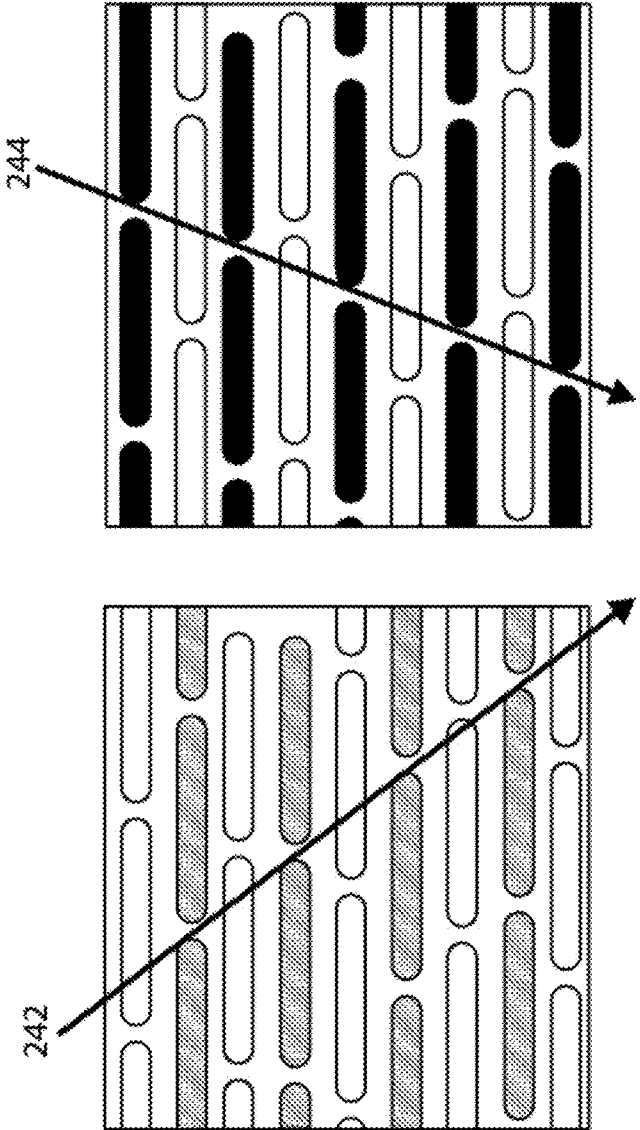


Fig. 16D

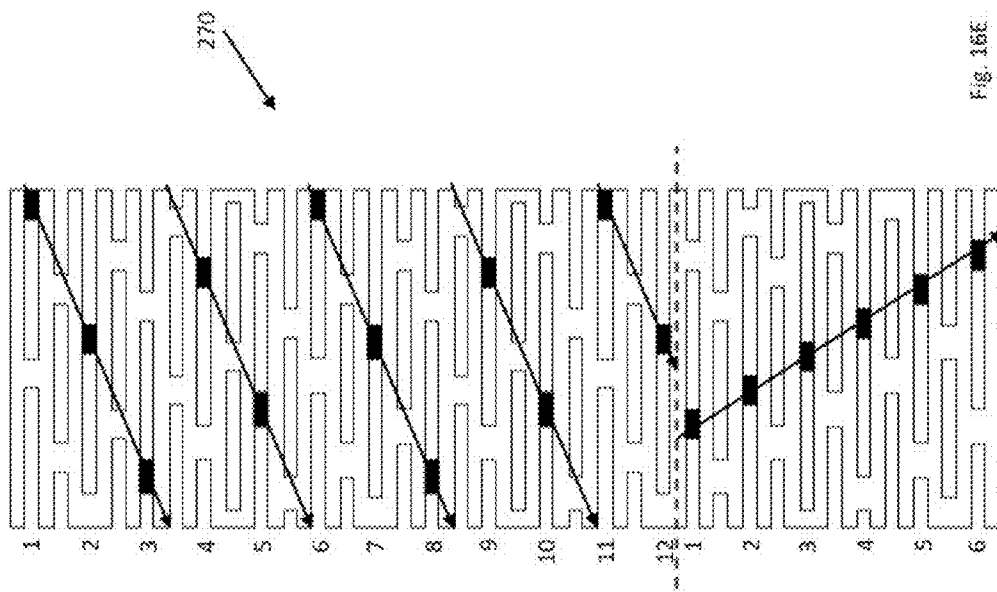


Fig. 16E

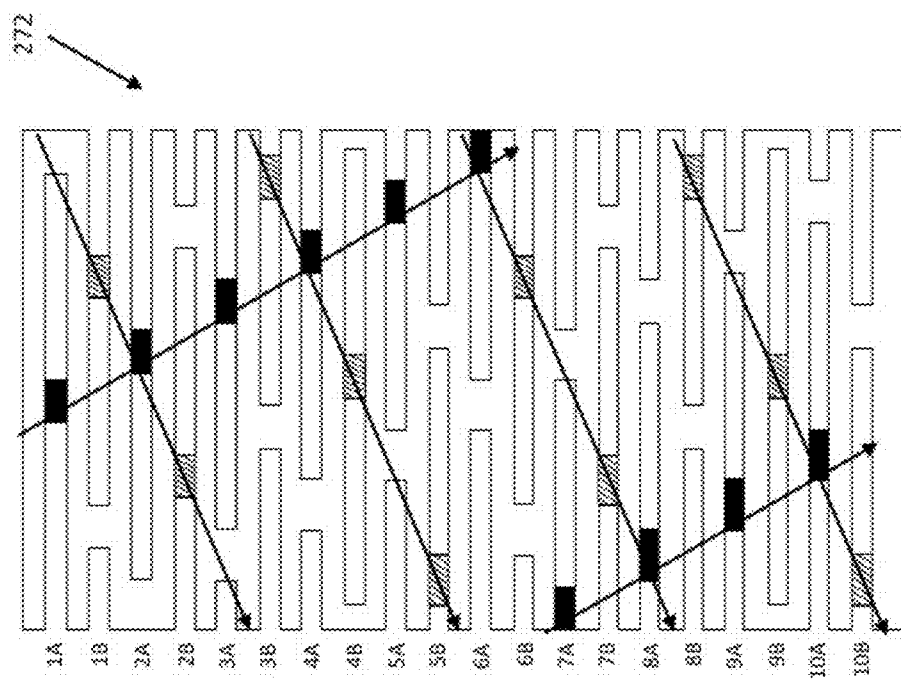


Fig. 16F

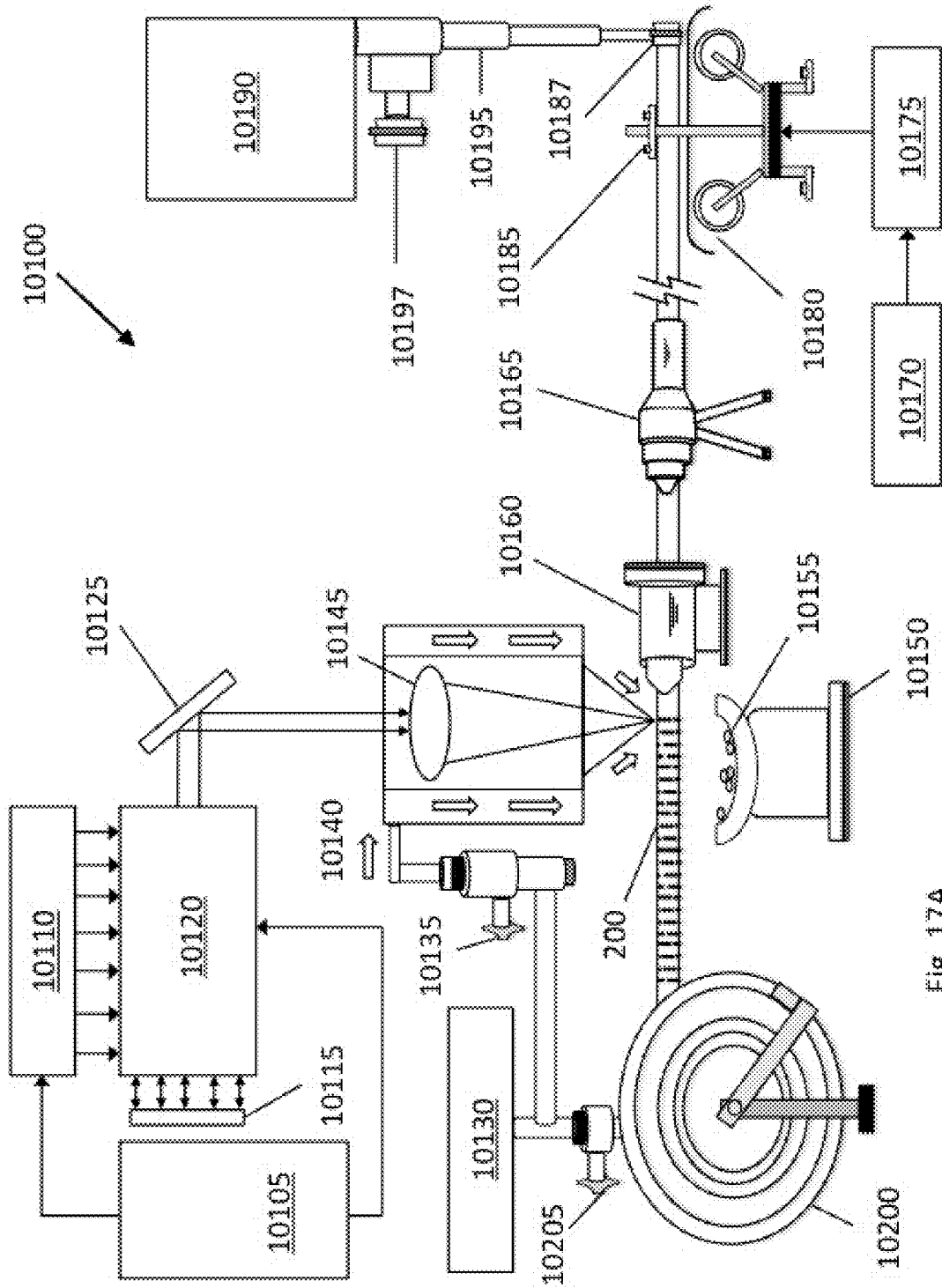


Fig. 17A

6400

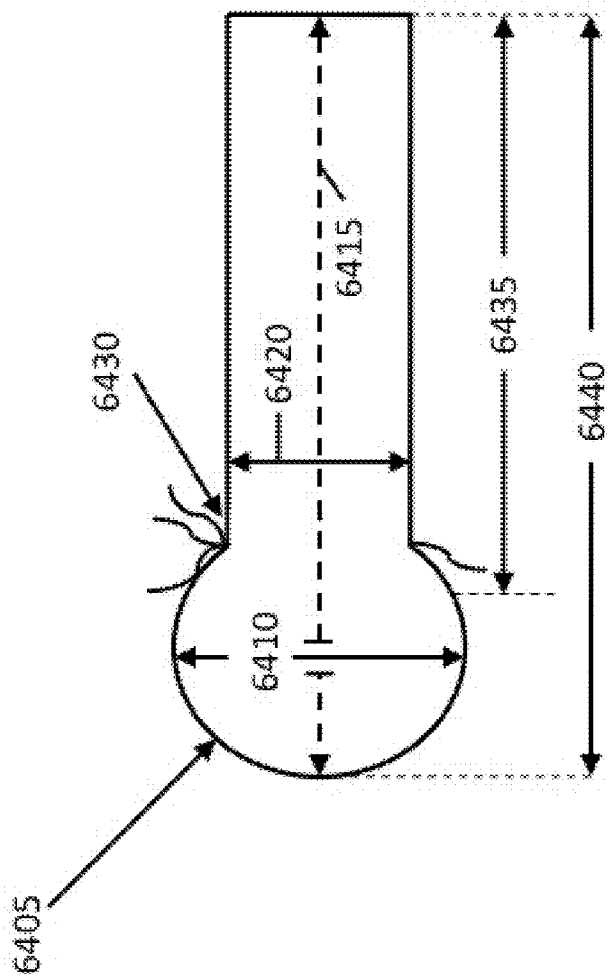


Fig. 17B

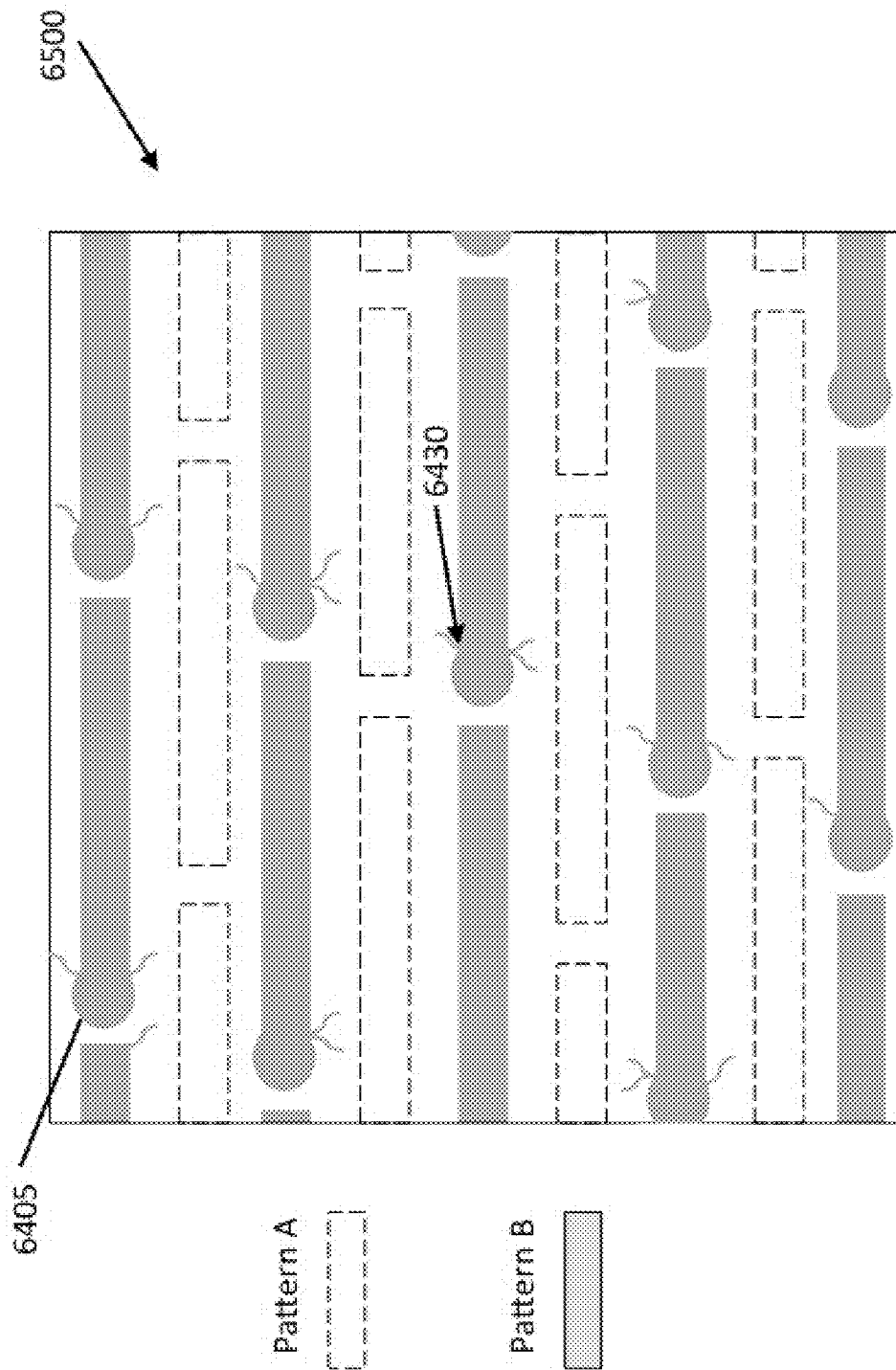


Fig. 17C

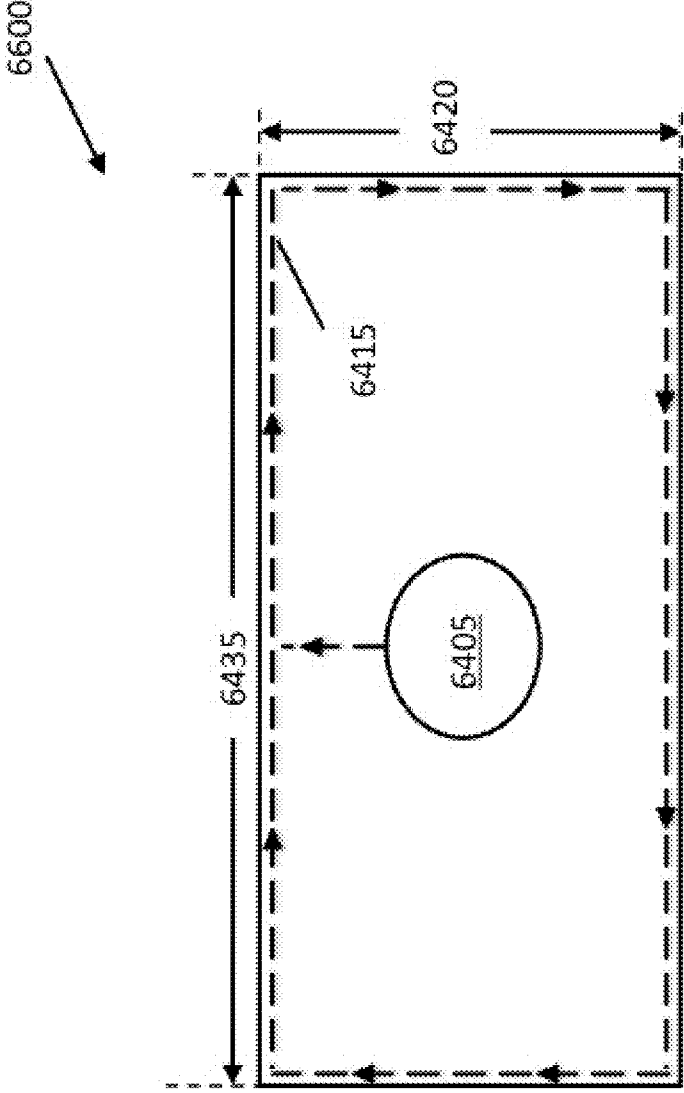


Fig. 17D



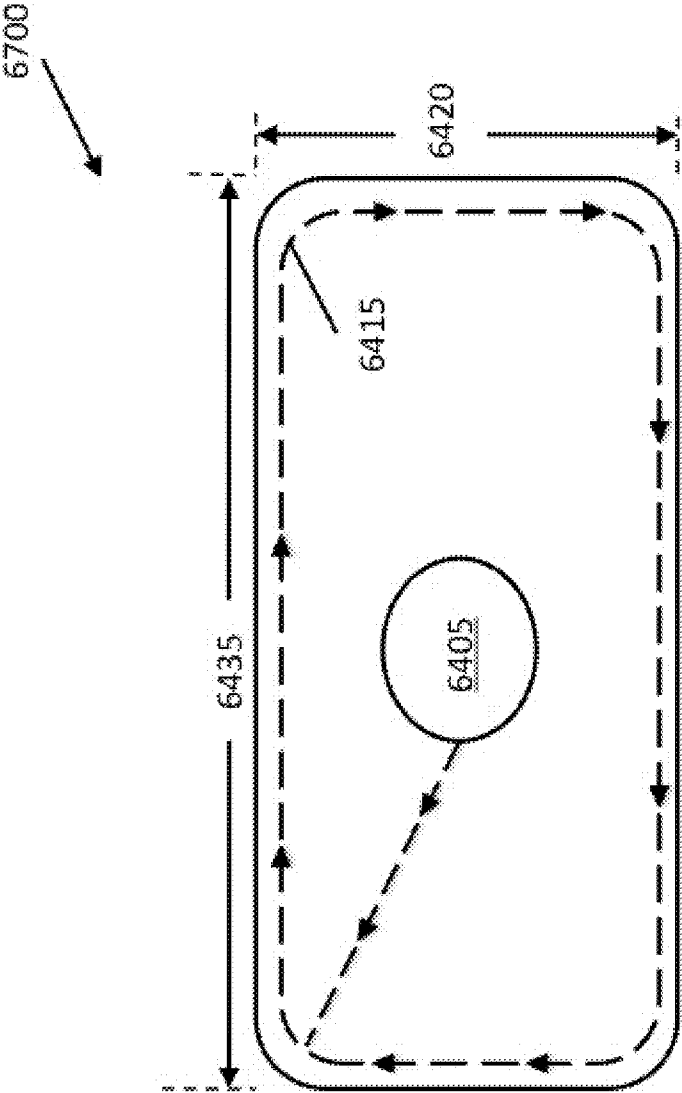


FIG. 17E



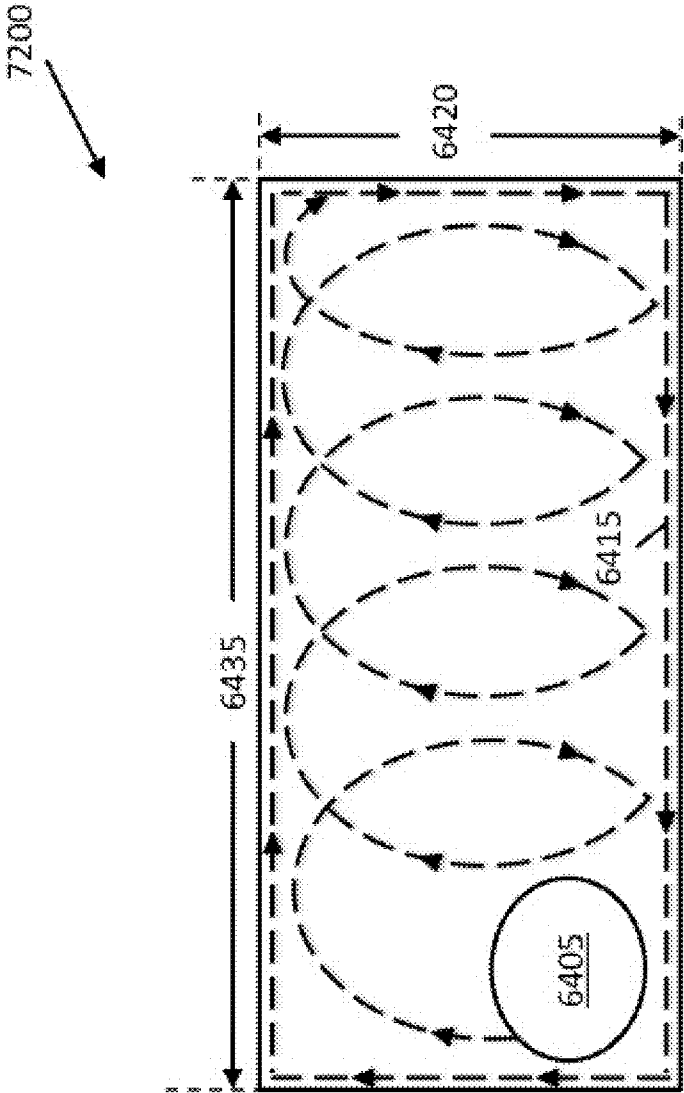


Fig. 17G

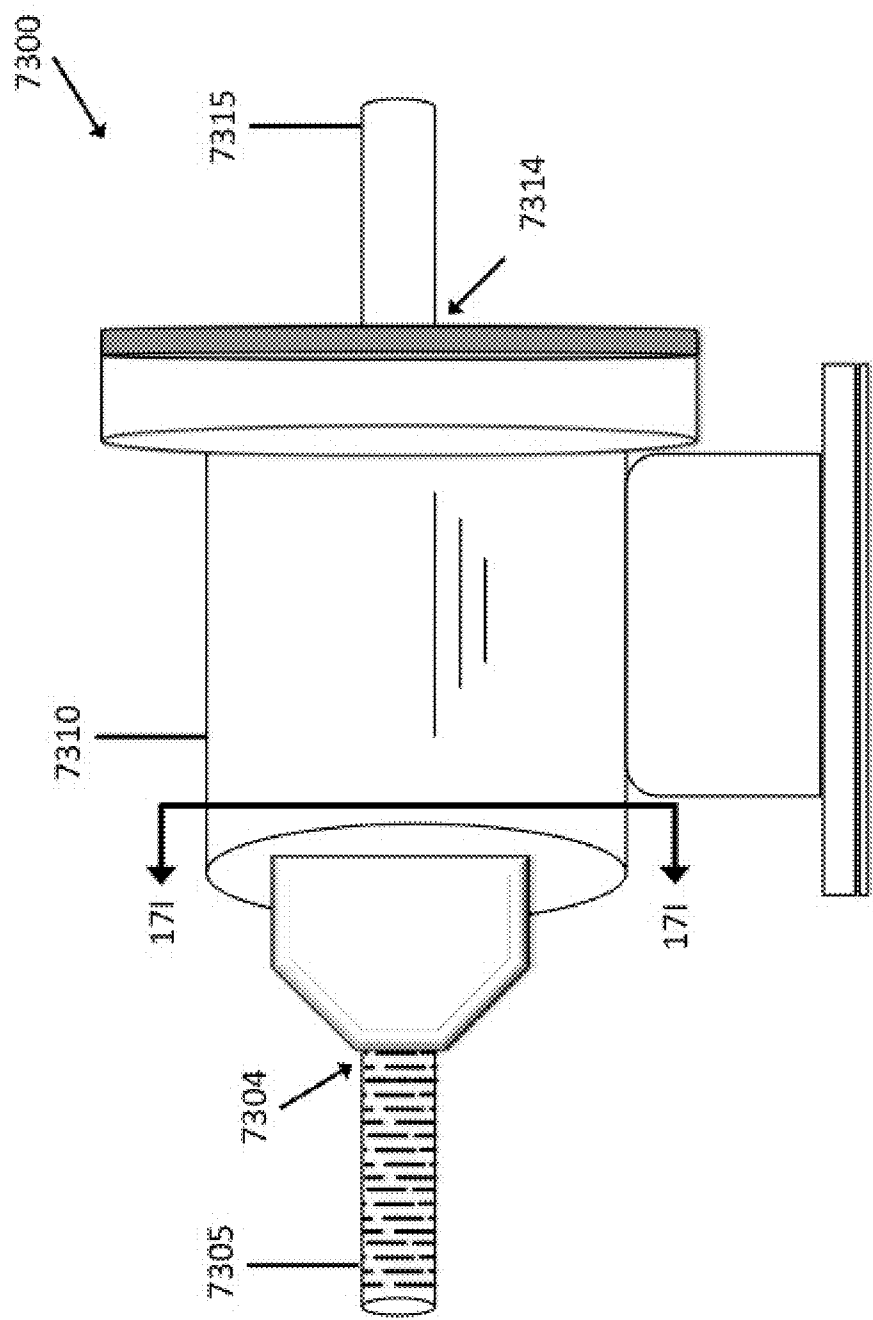


Fig. 17H

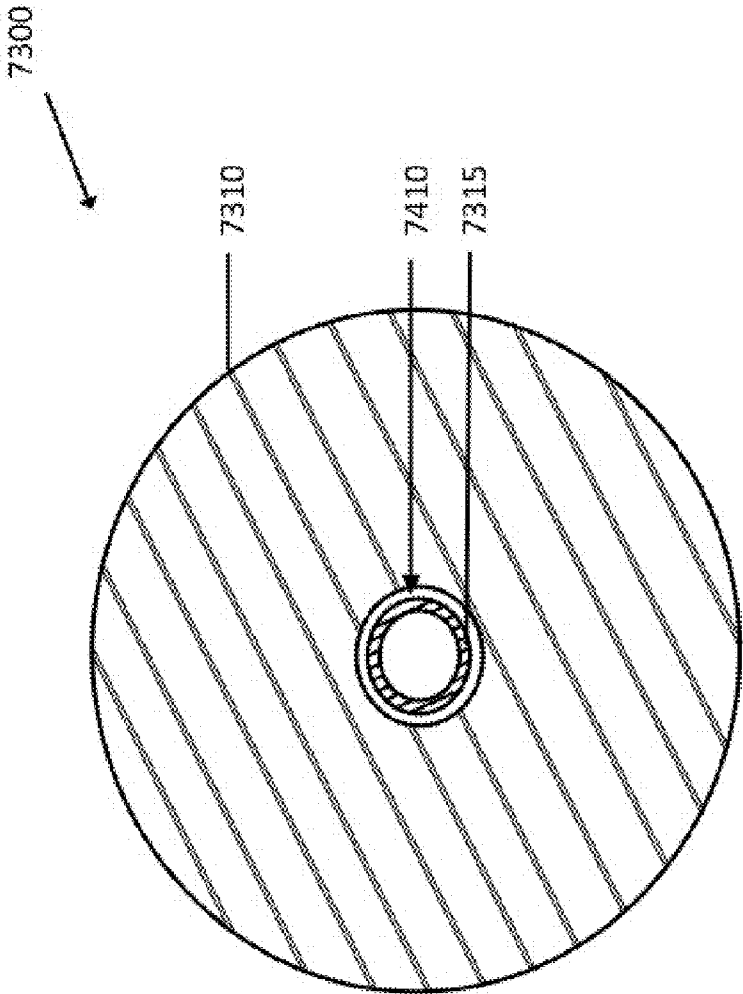


Fig. 171

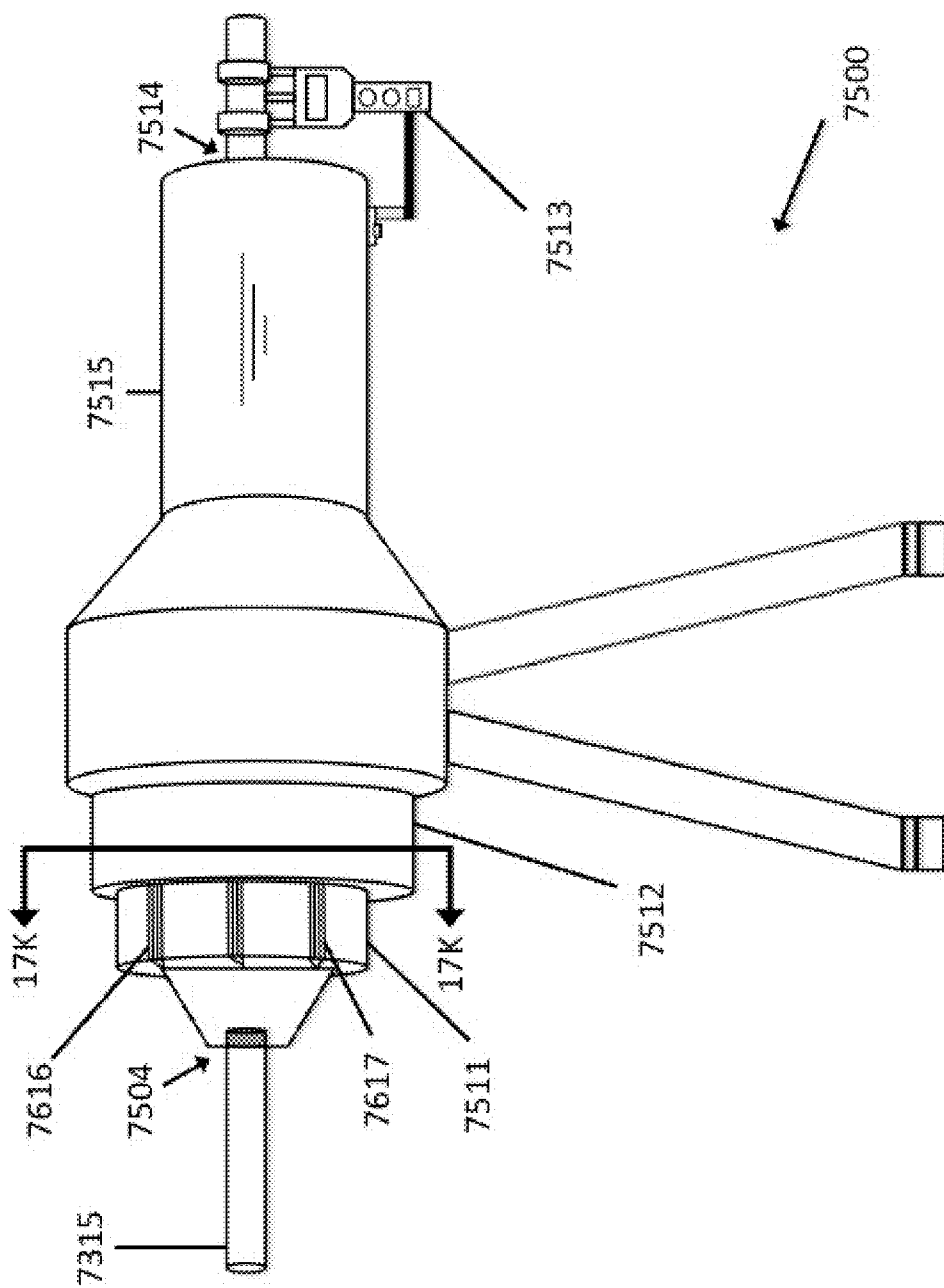


Fig. 17J

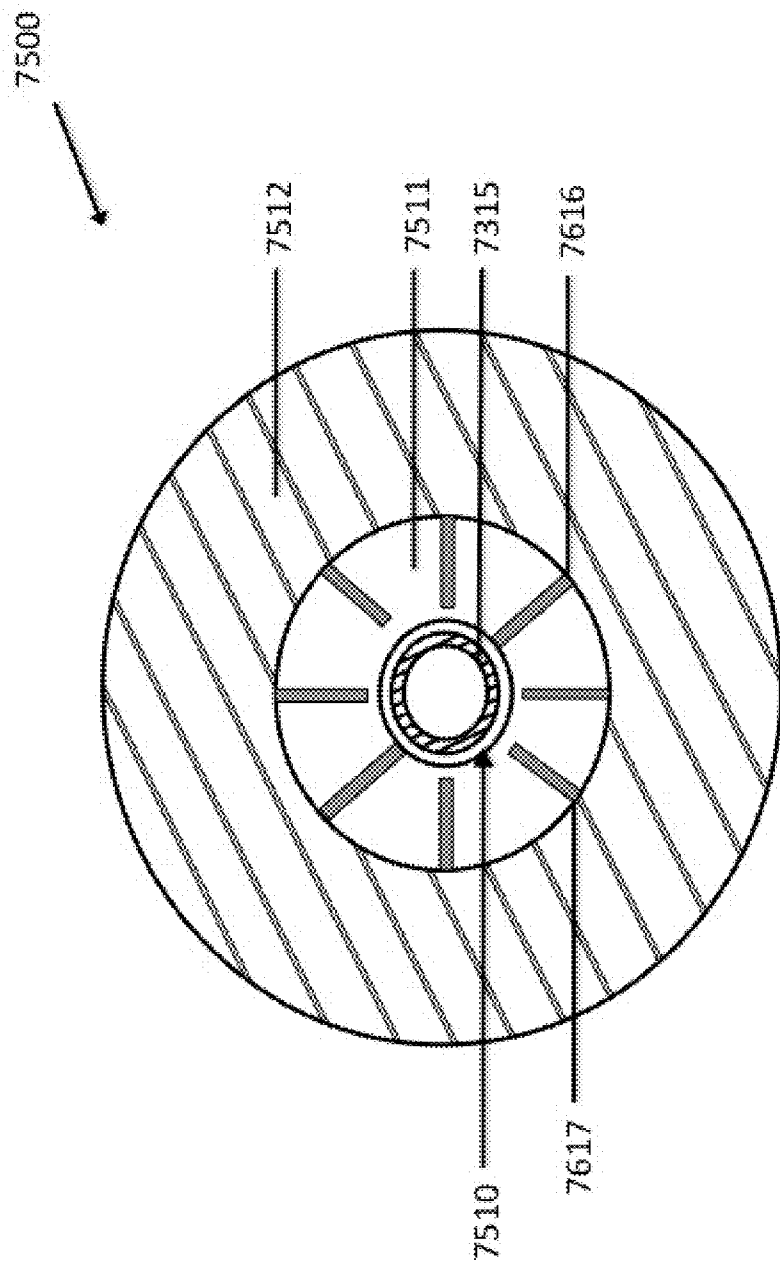


Fig. 17K

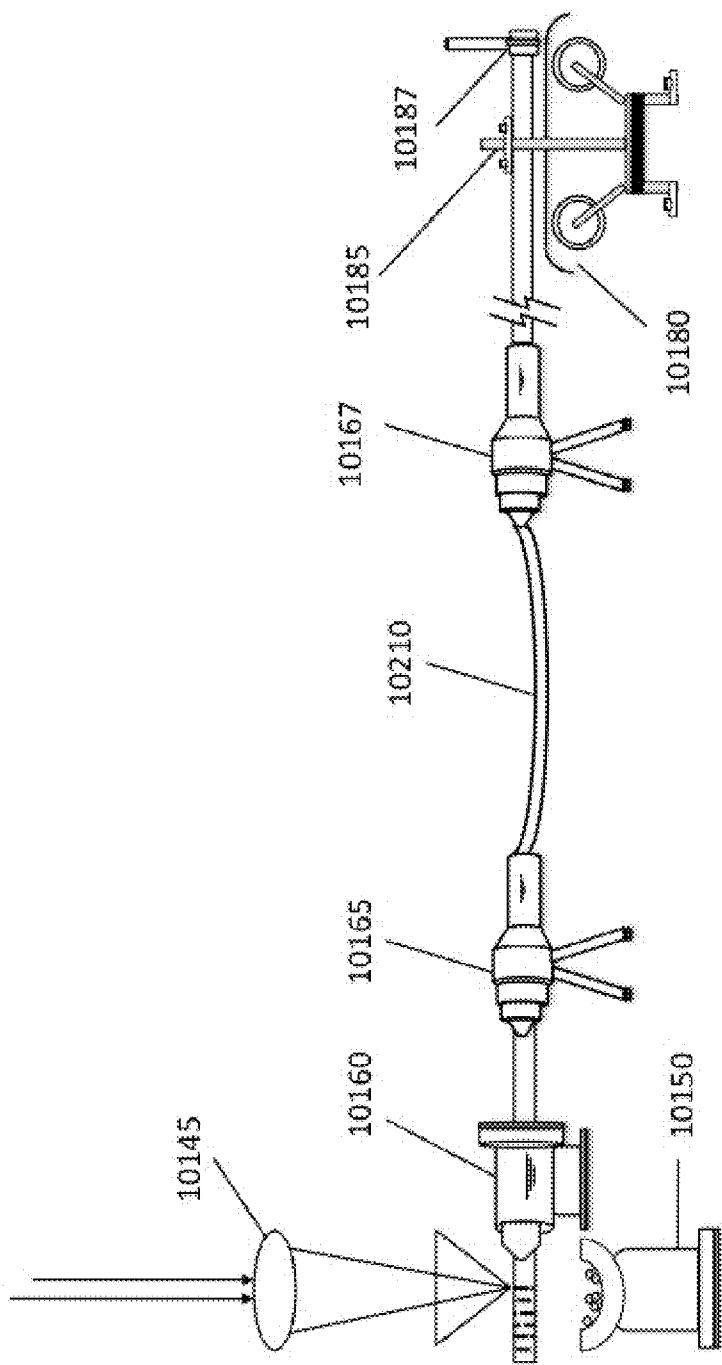


FIG. 17L



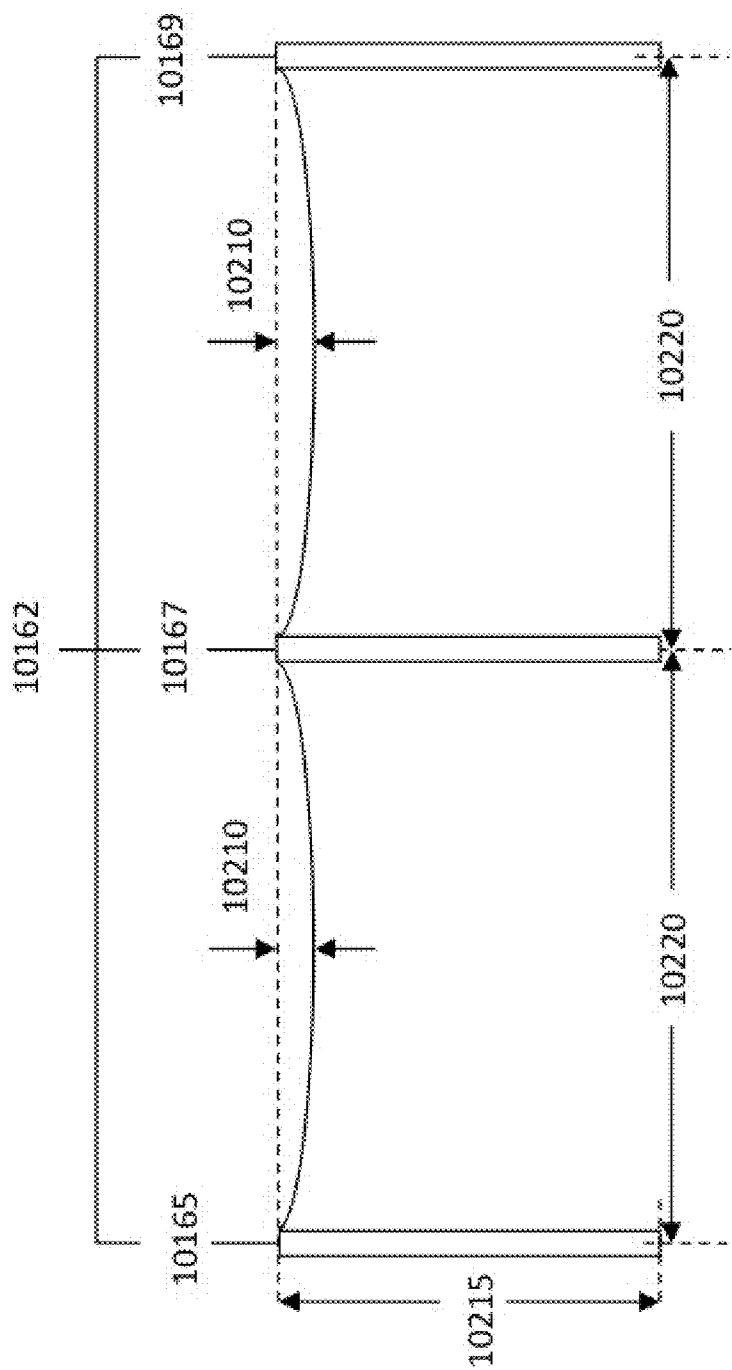


Fig. 17M

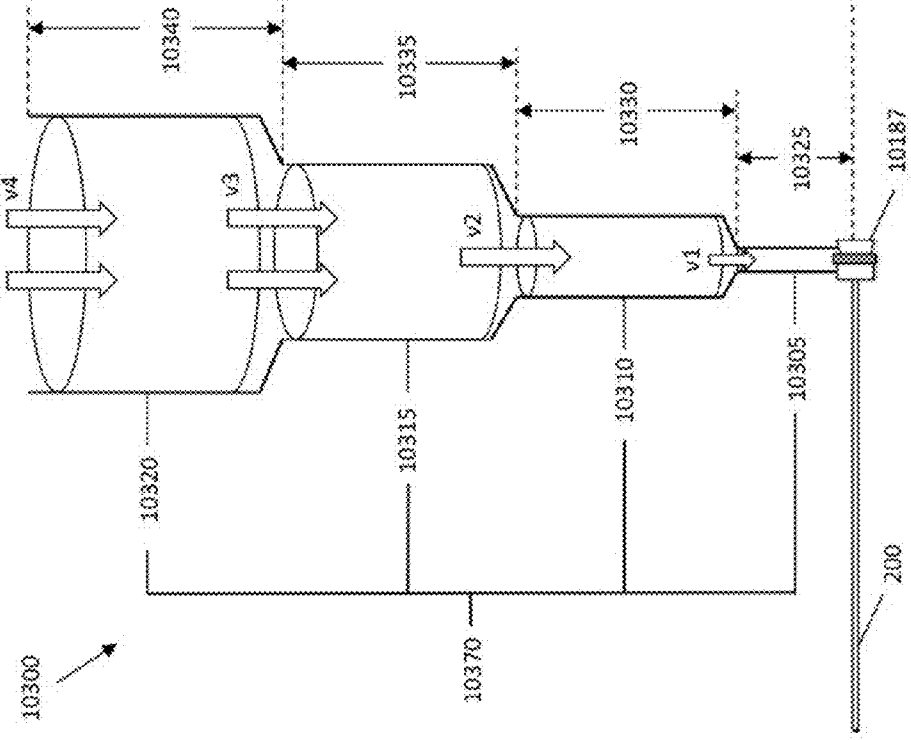


Fig. 17N

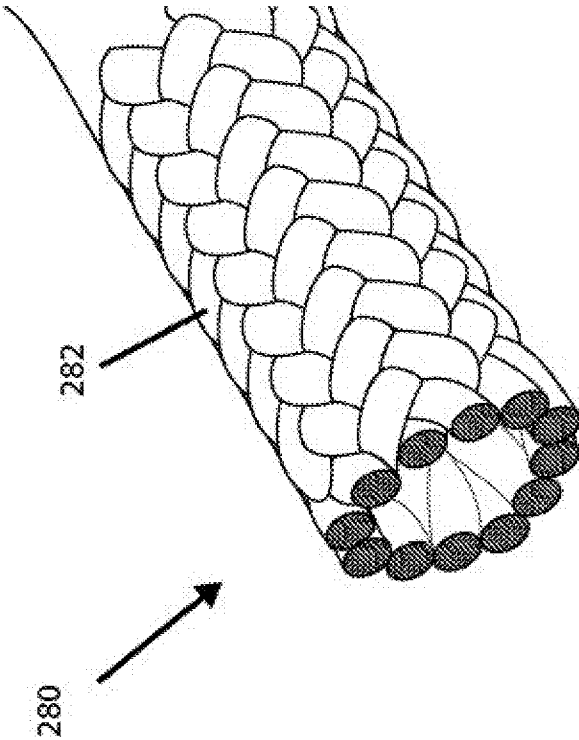


Fig. 18A

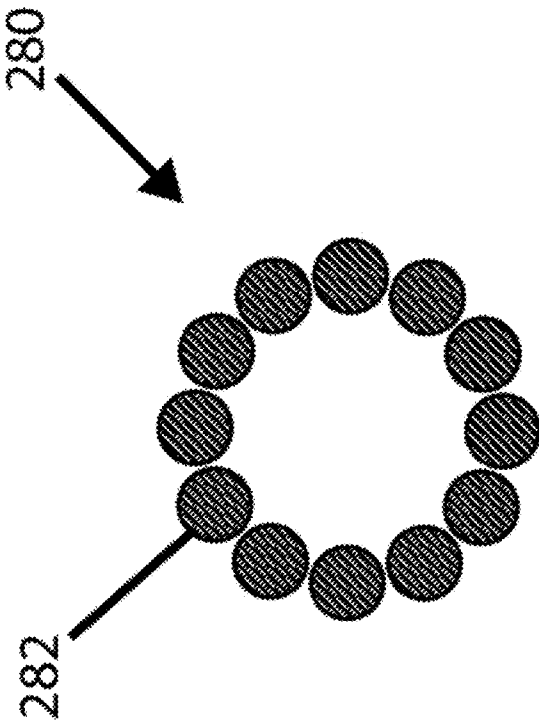


Fig. 18B

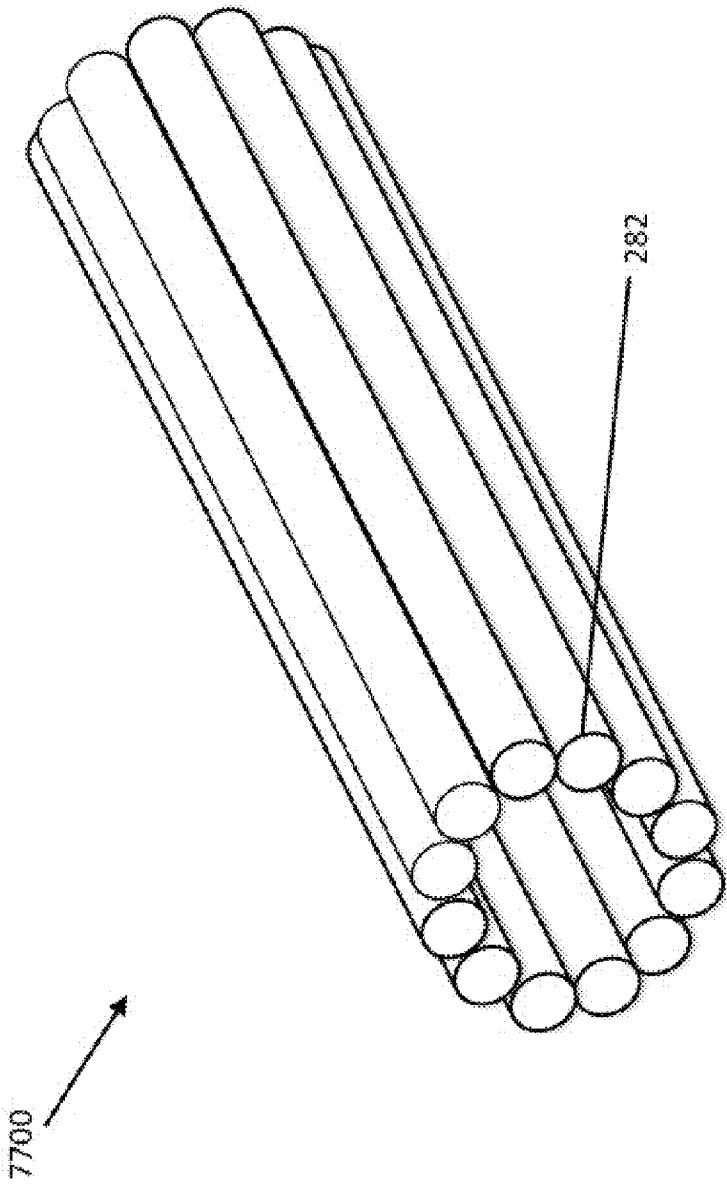


Fig. 18C

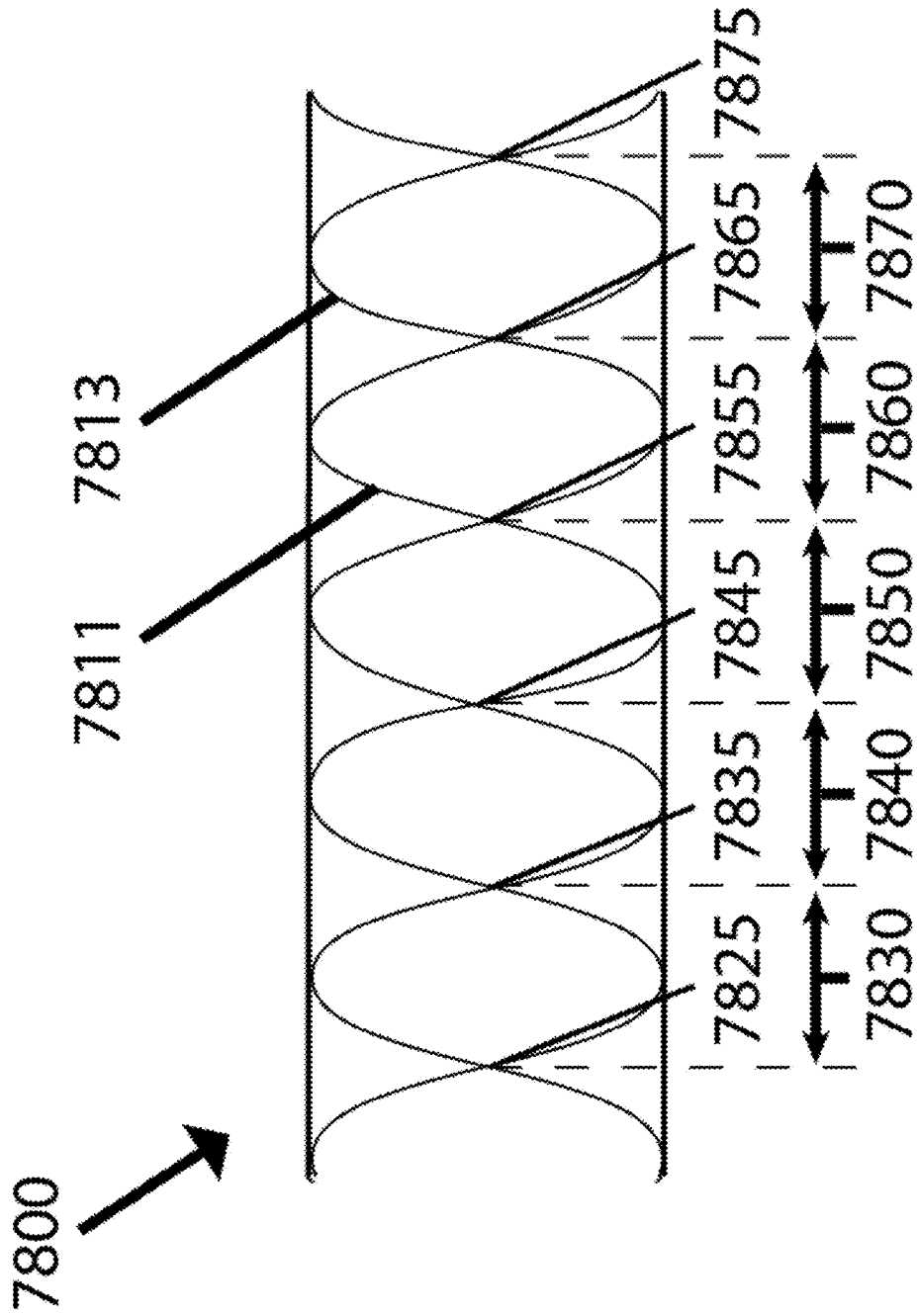


Fig. 18D

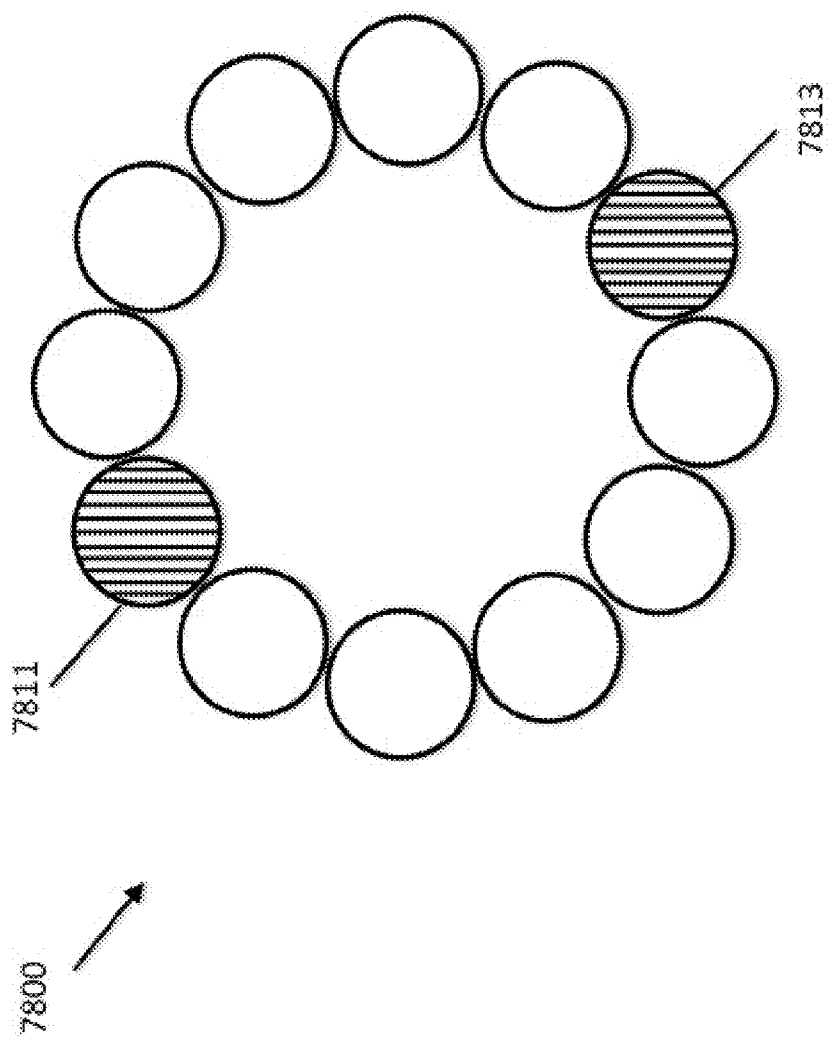


FIG. 18E

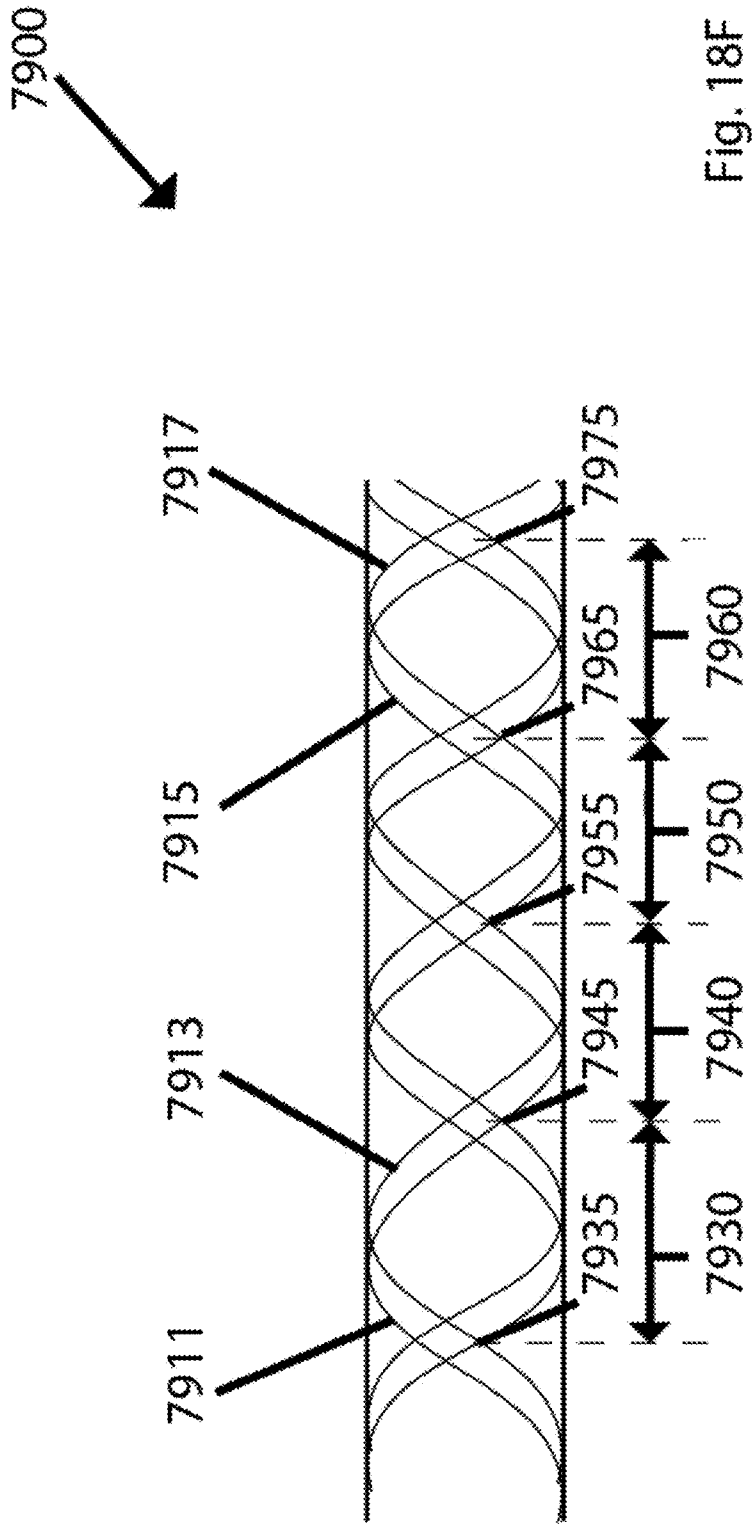


Fig. 18F



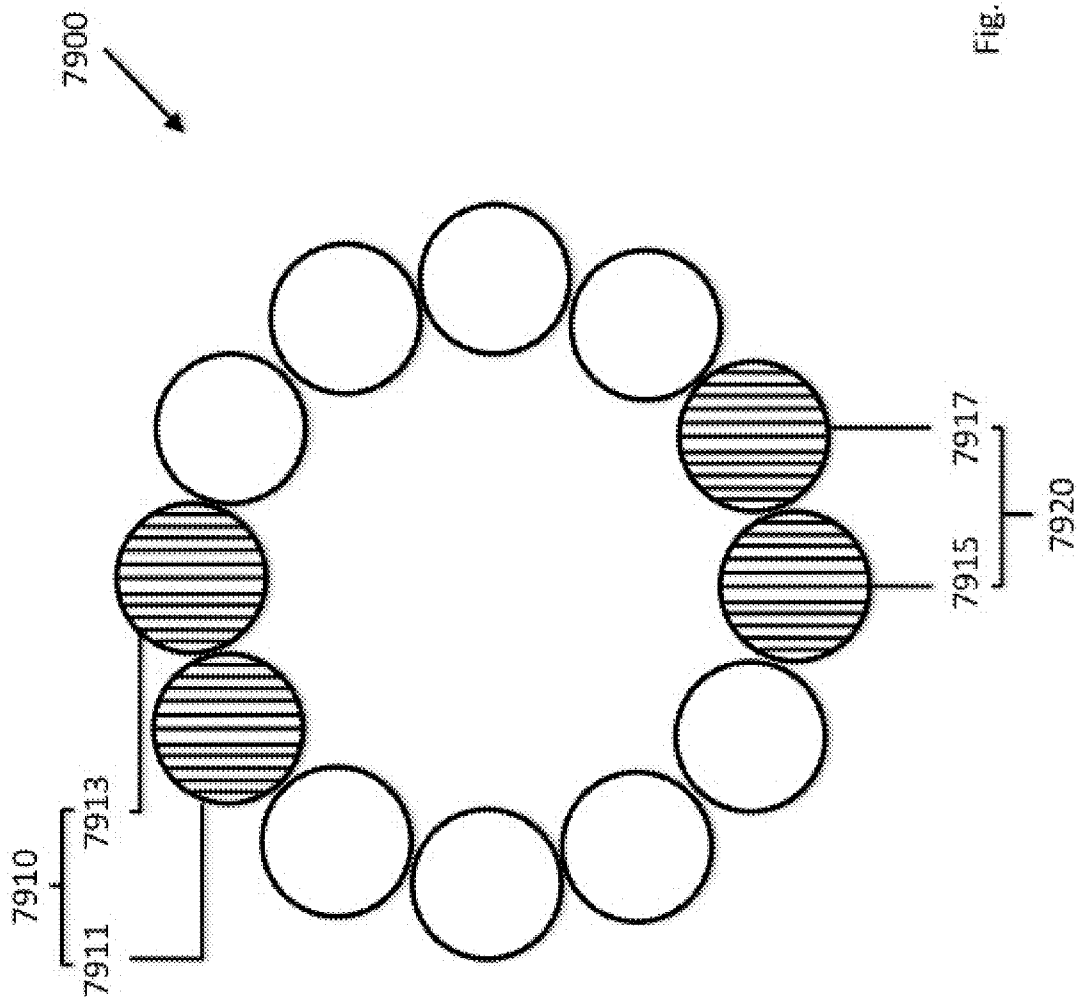


Fig. 18G

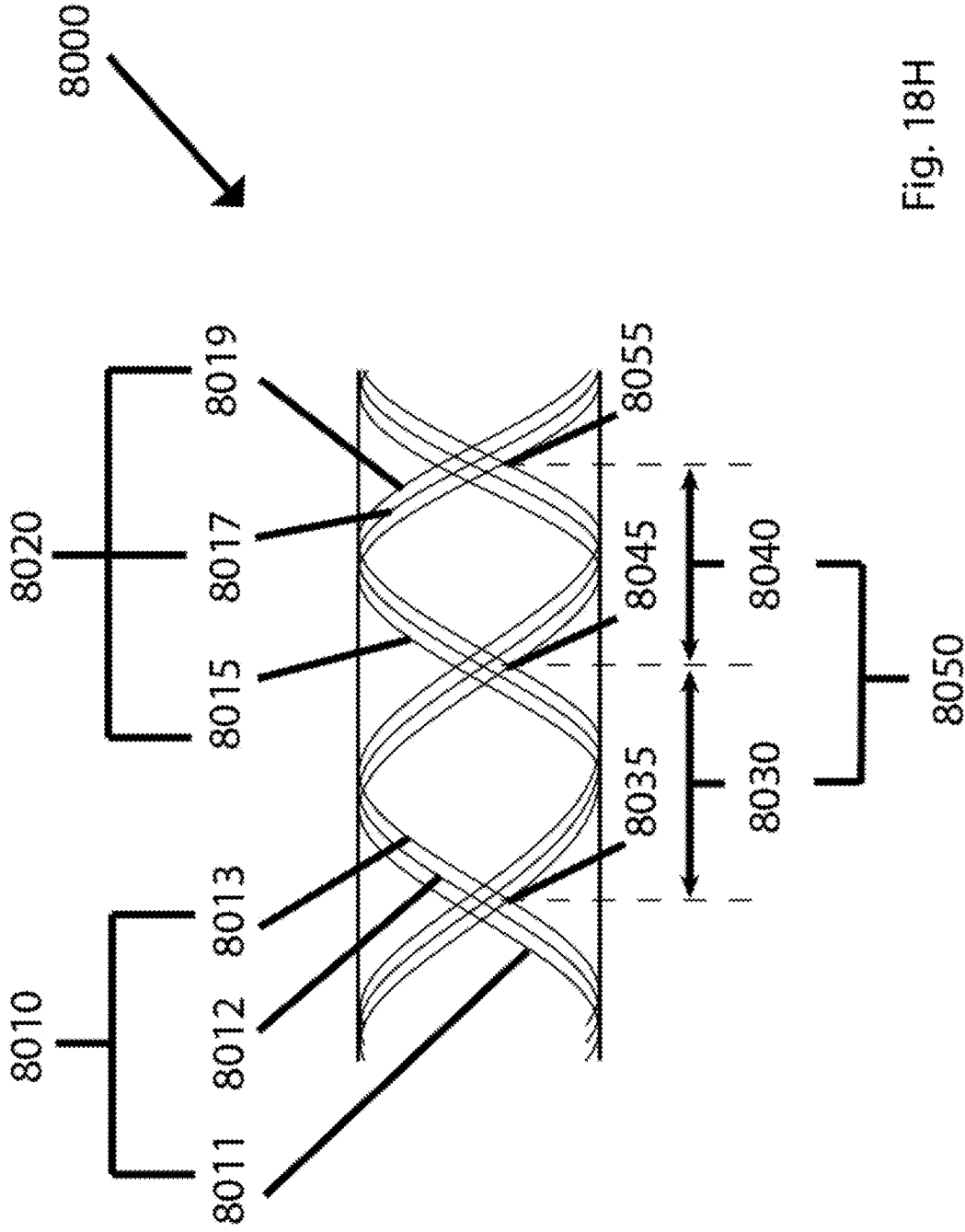


Fig. 18H

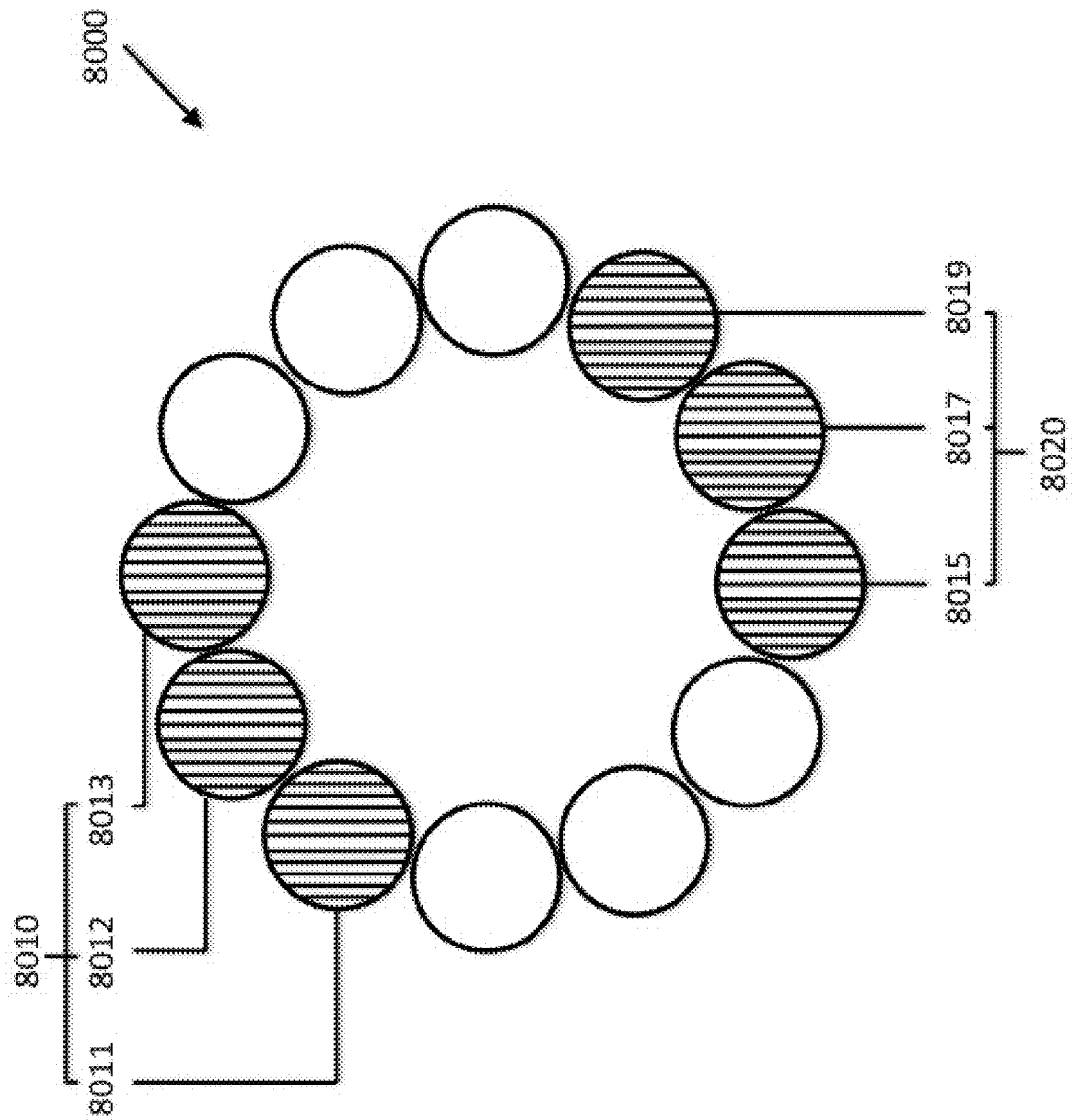


Fig. 18f

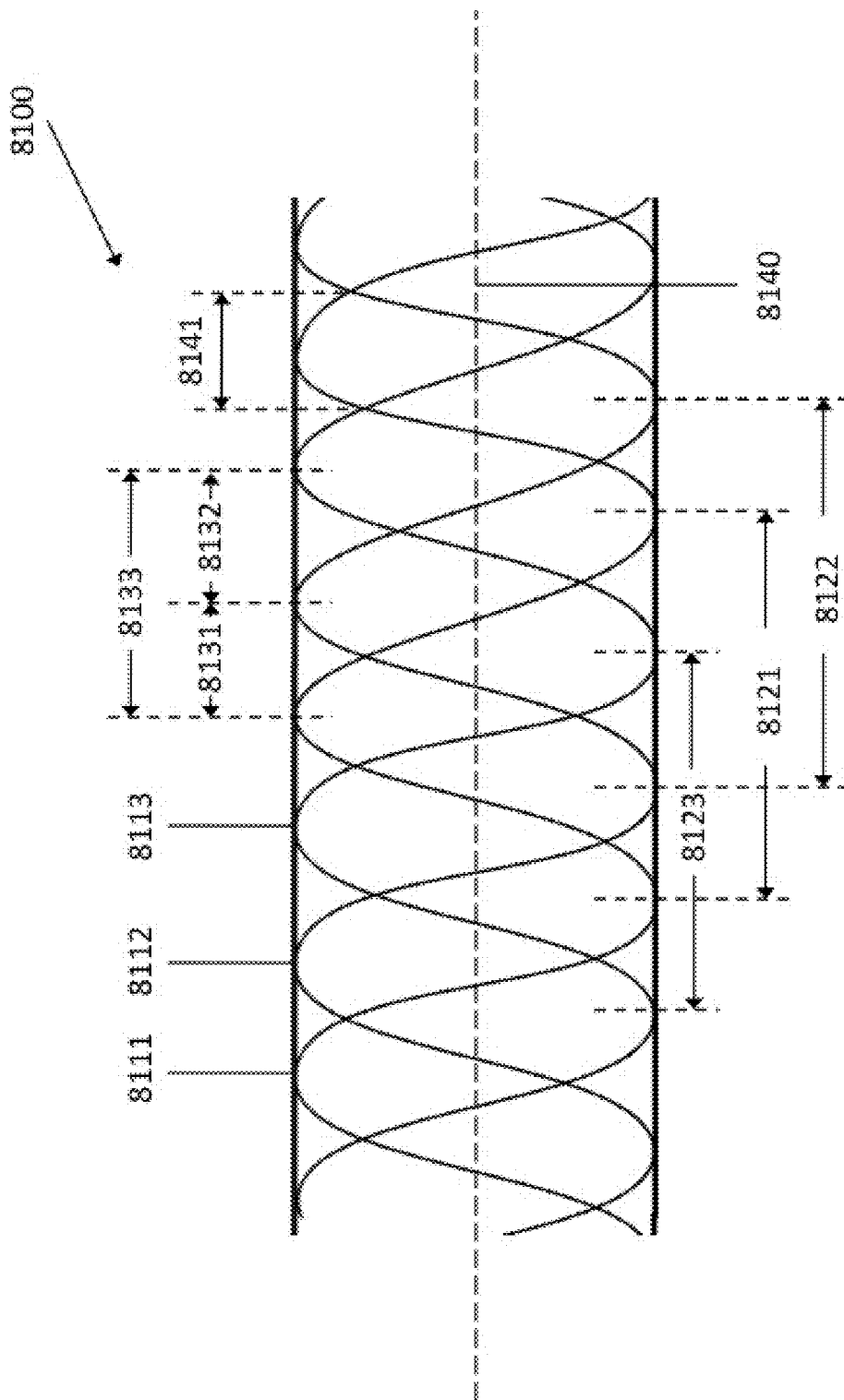


FIG. 18J

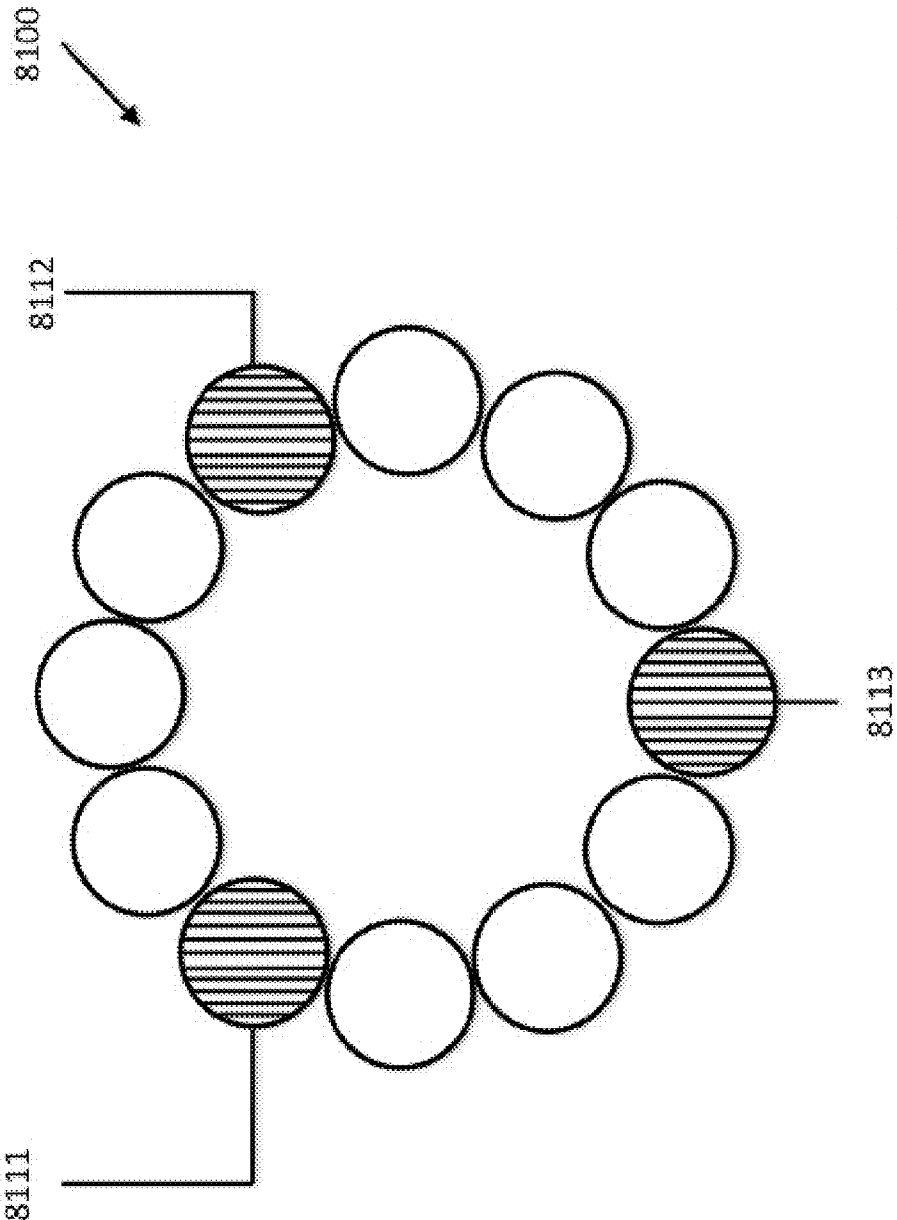


Fig. 18K

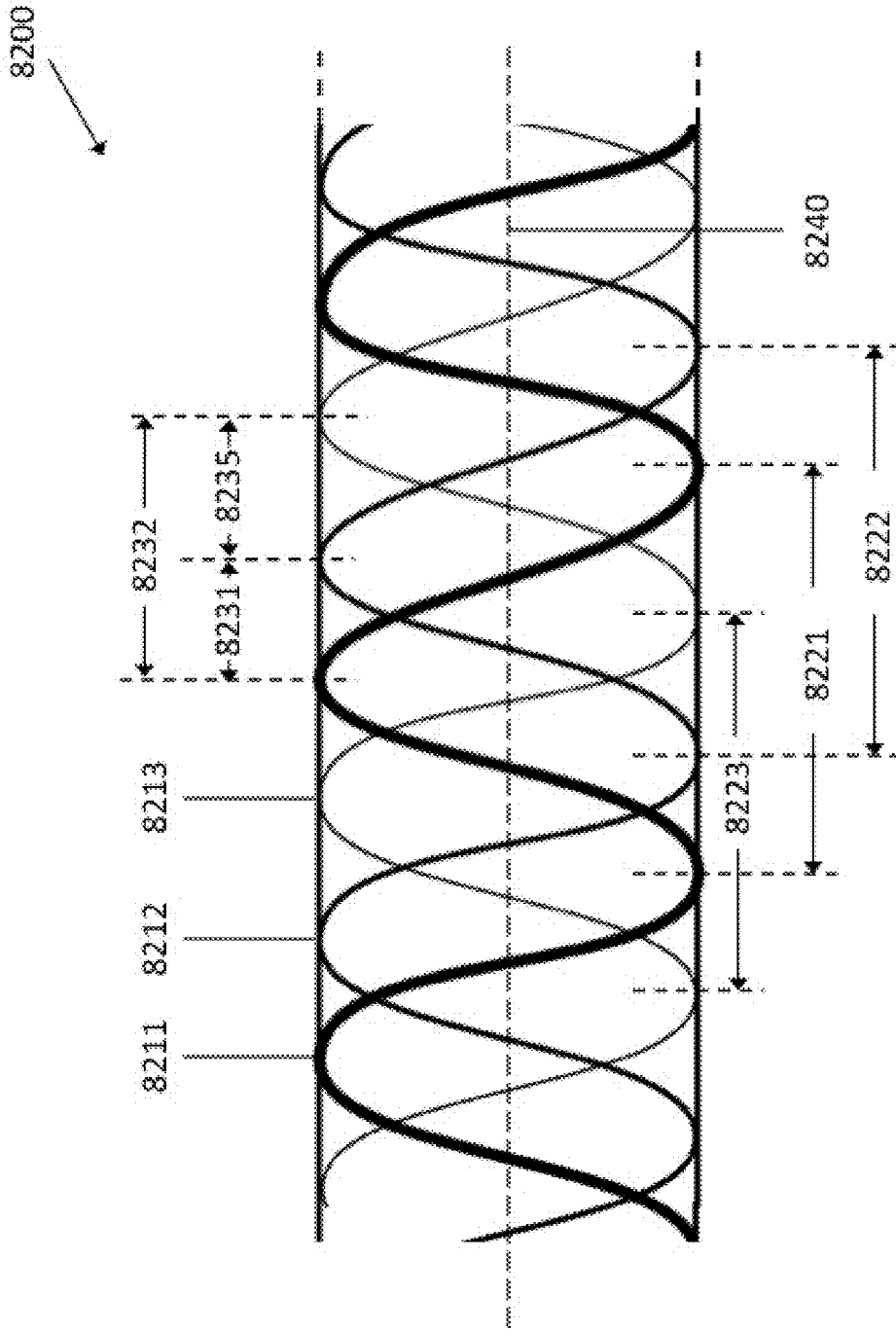


Fig. 18L

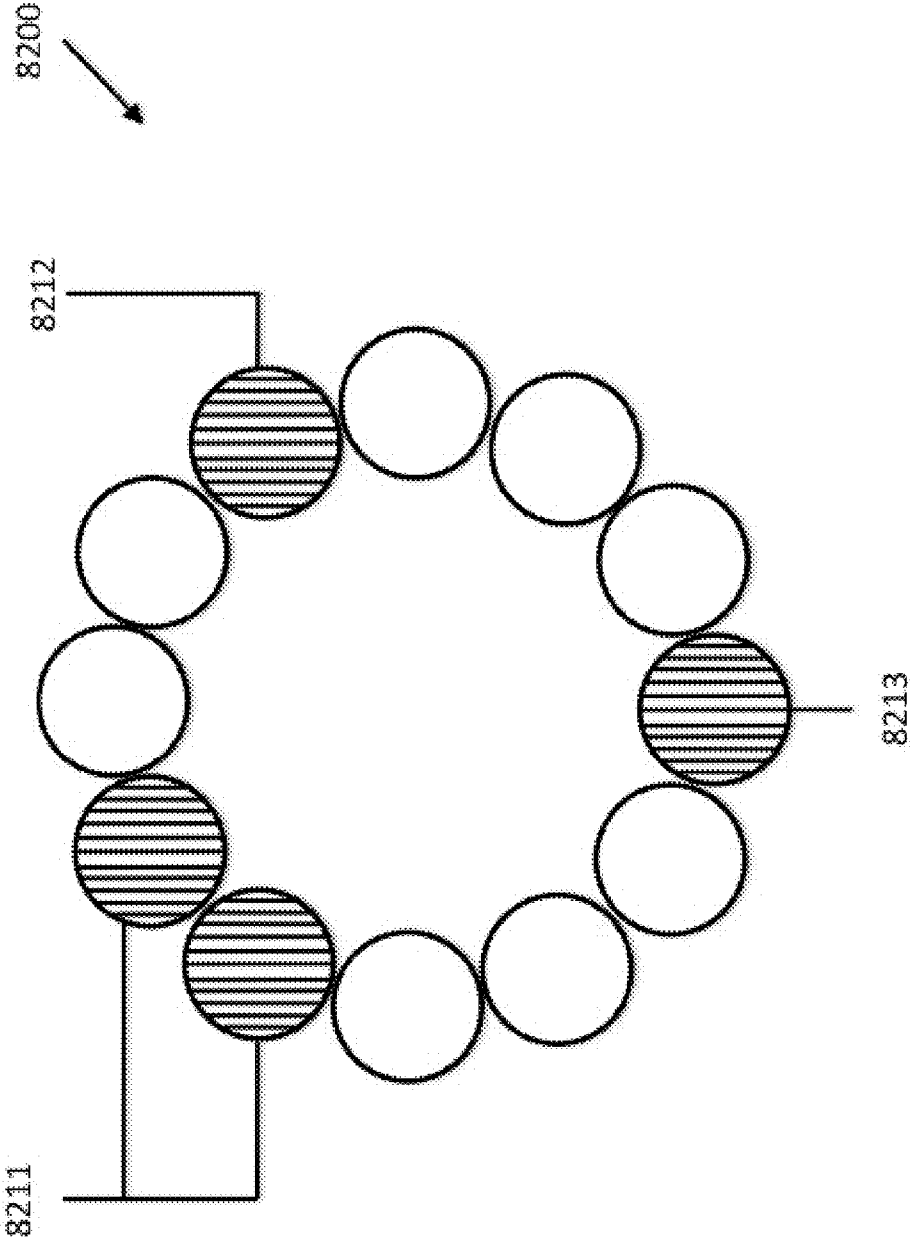


Fig. 18M

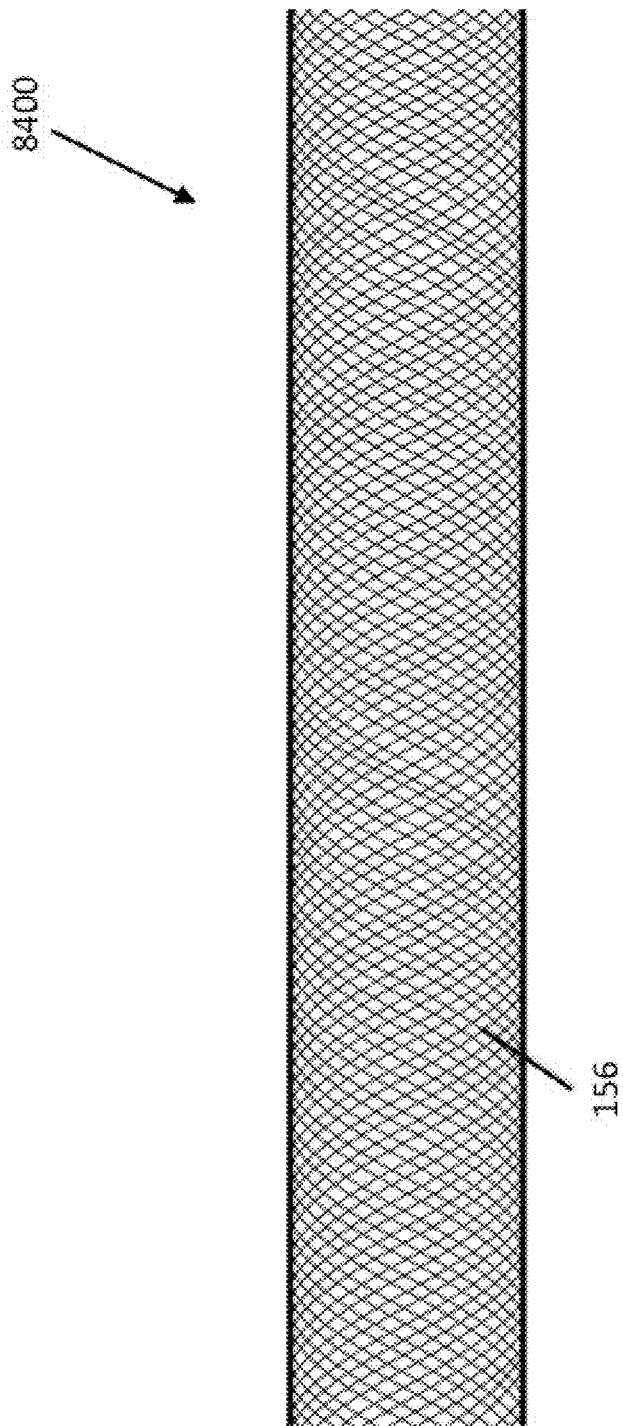


Fig. 18N



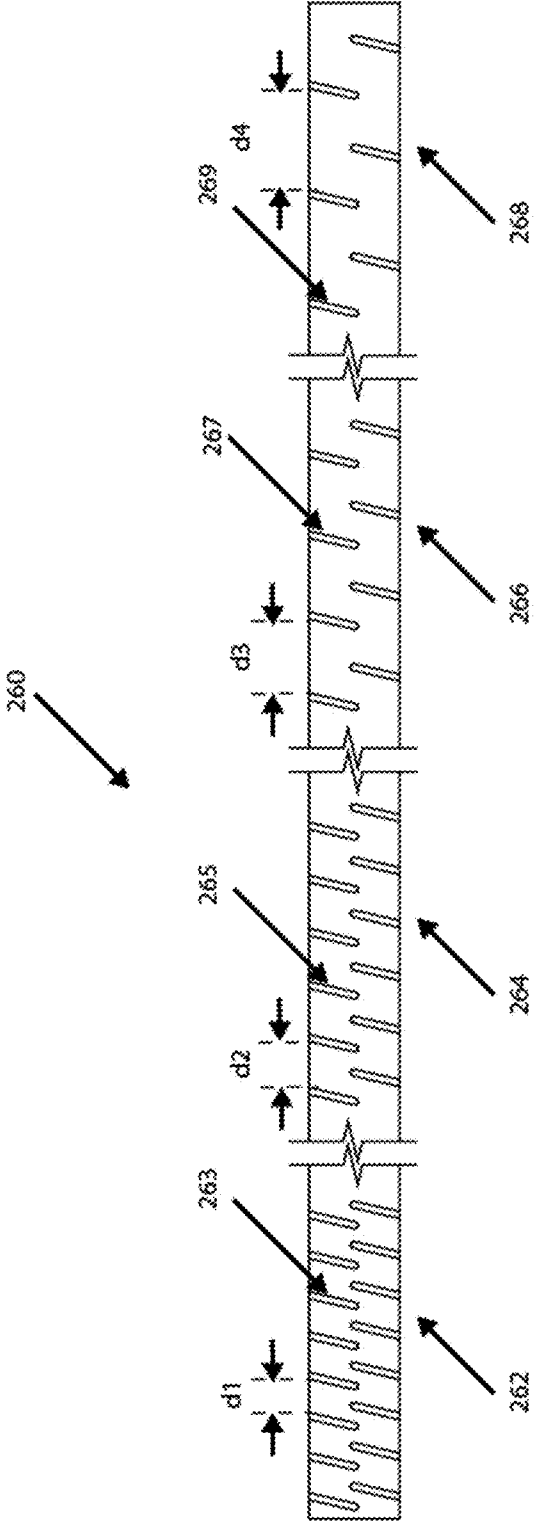


Fig. 19A

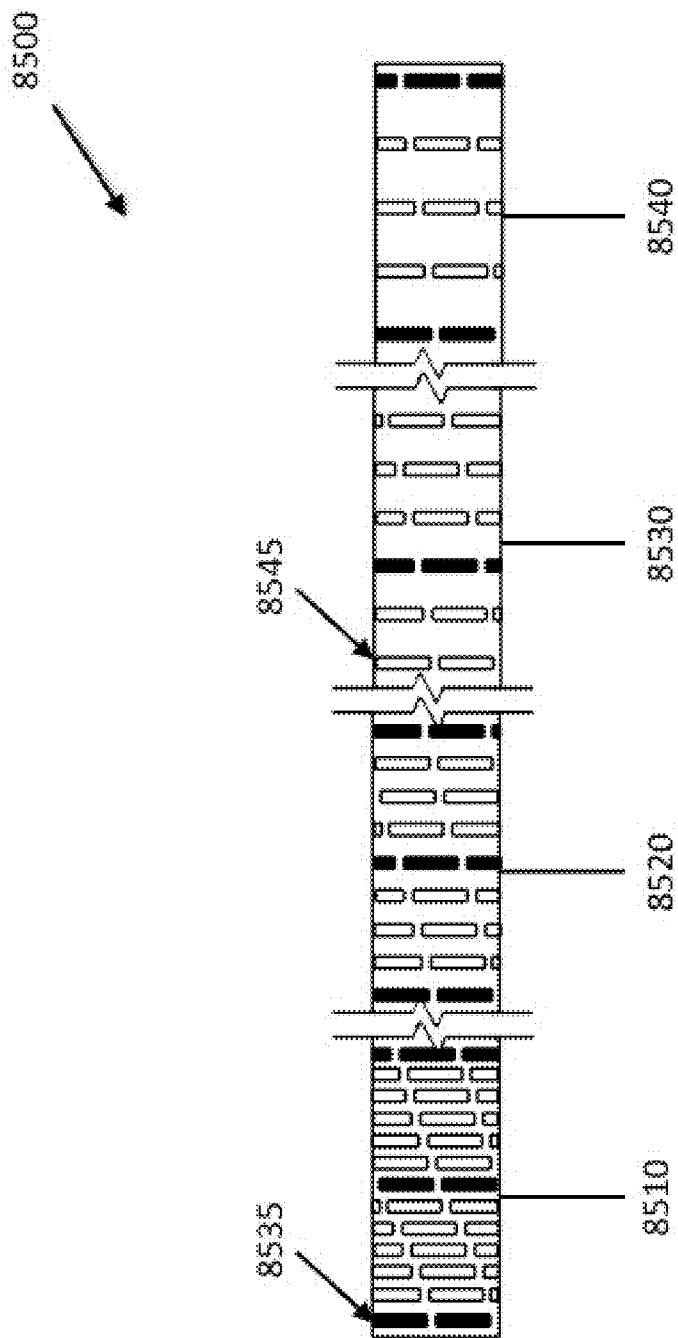


Fig. 19B

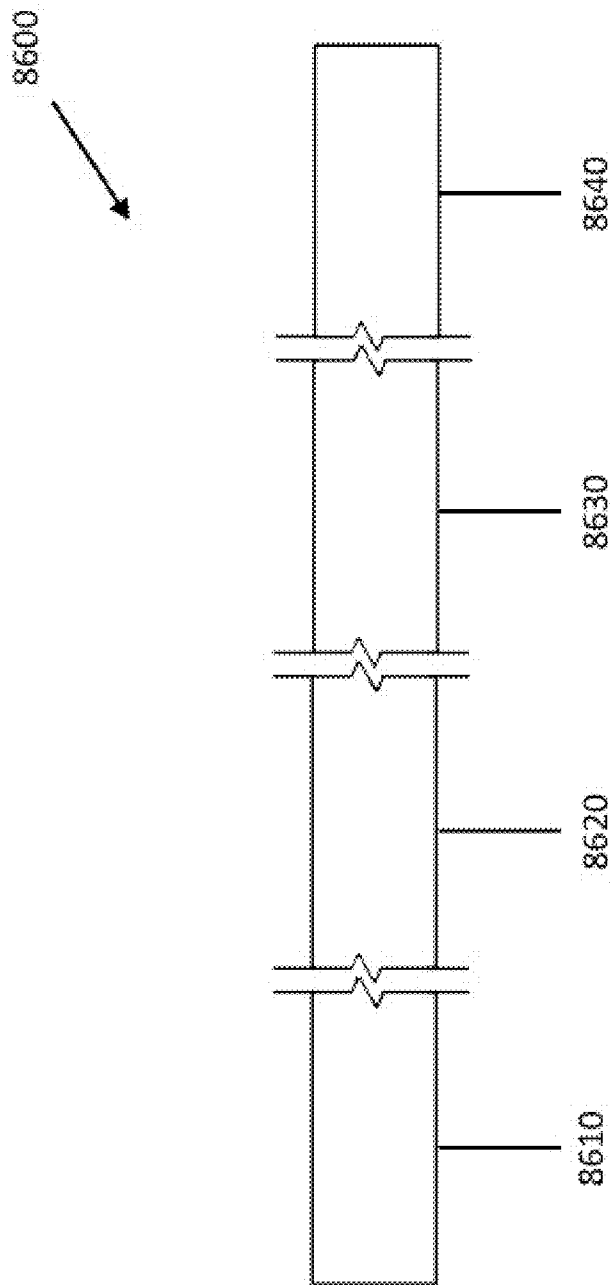


Fig. 19C

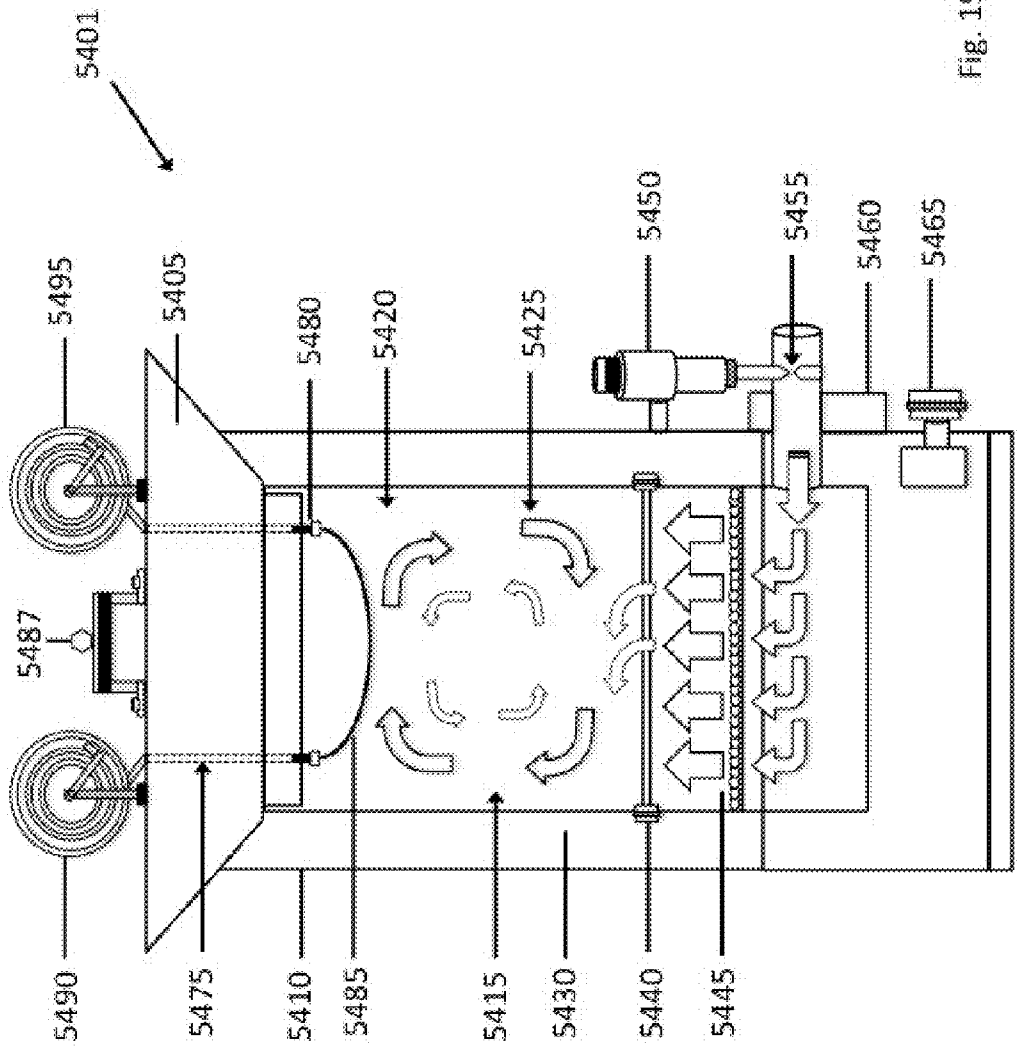


Fig. 19D

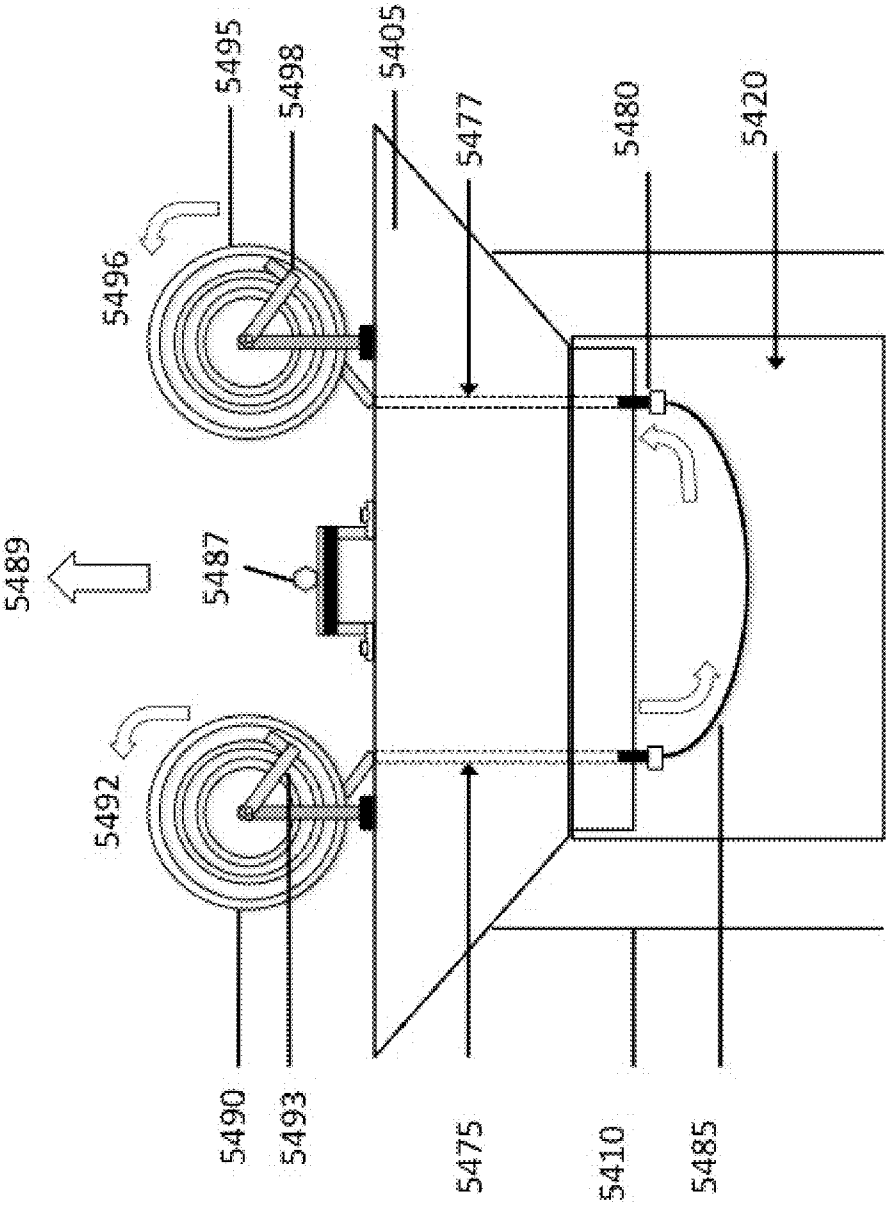


Fig. 19E

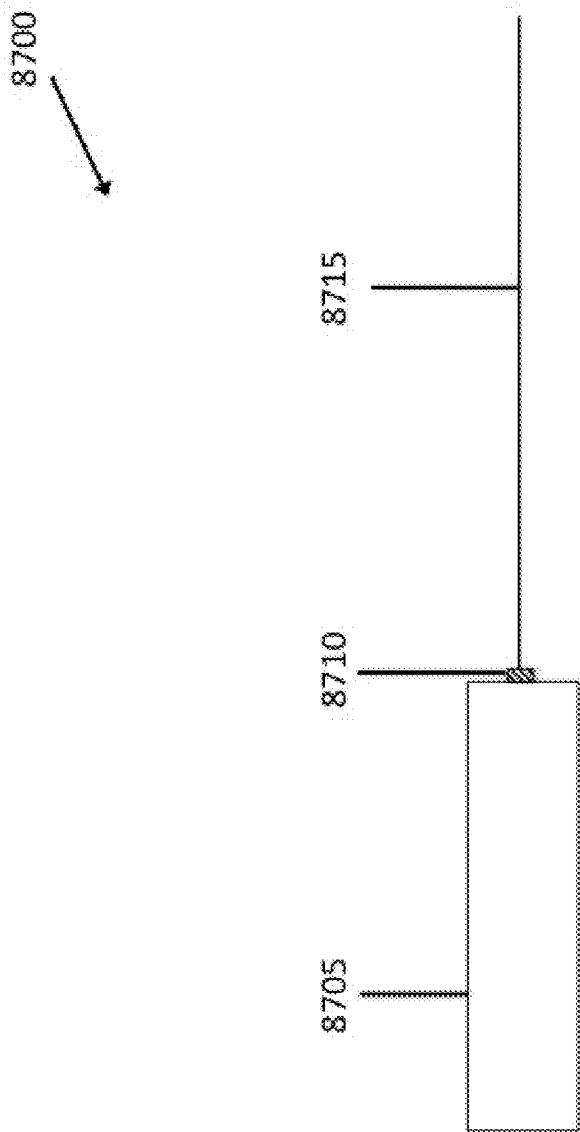


FIG. 19F

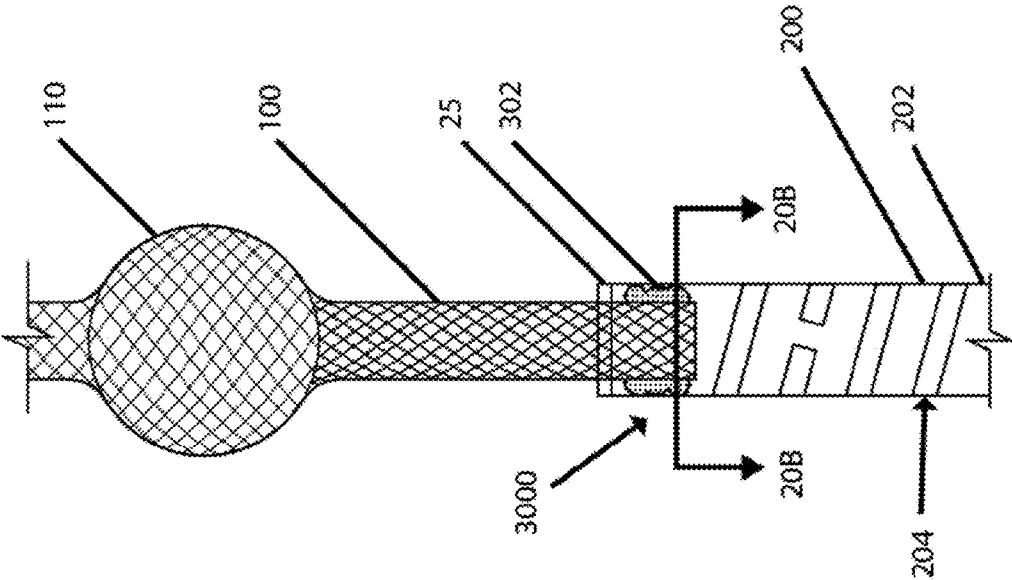


Fig. 20A

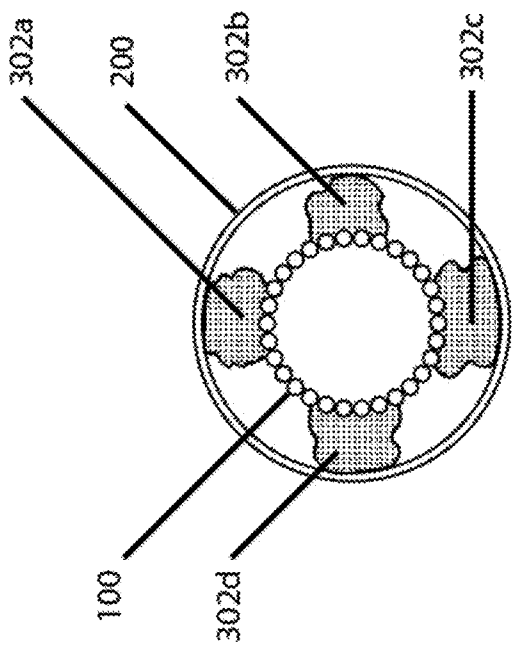


Fig. 20B



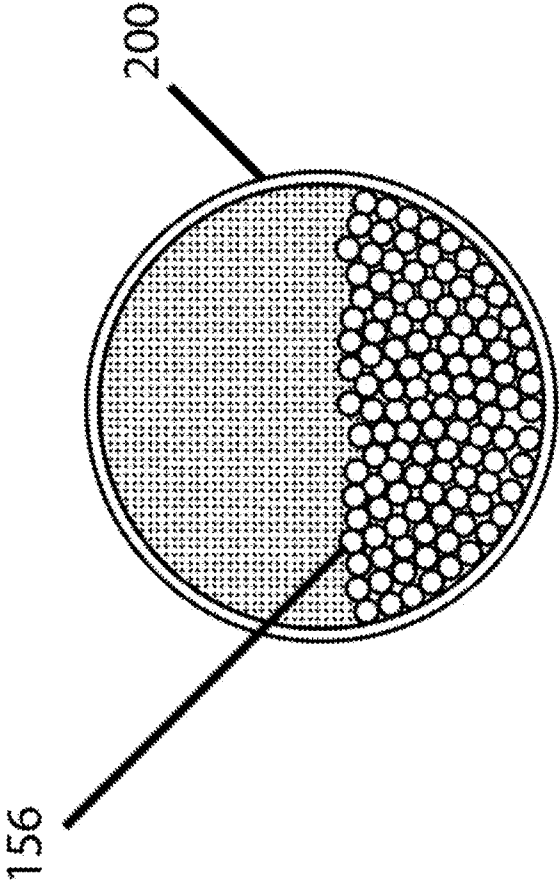


Fig. 20C

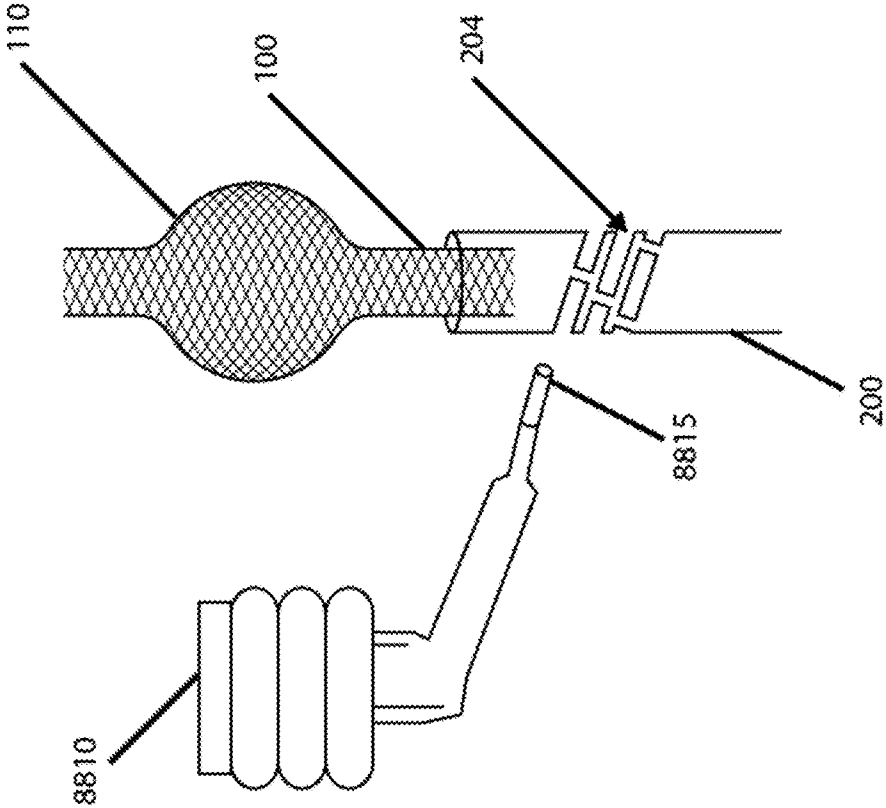


Fig. 20D

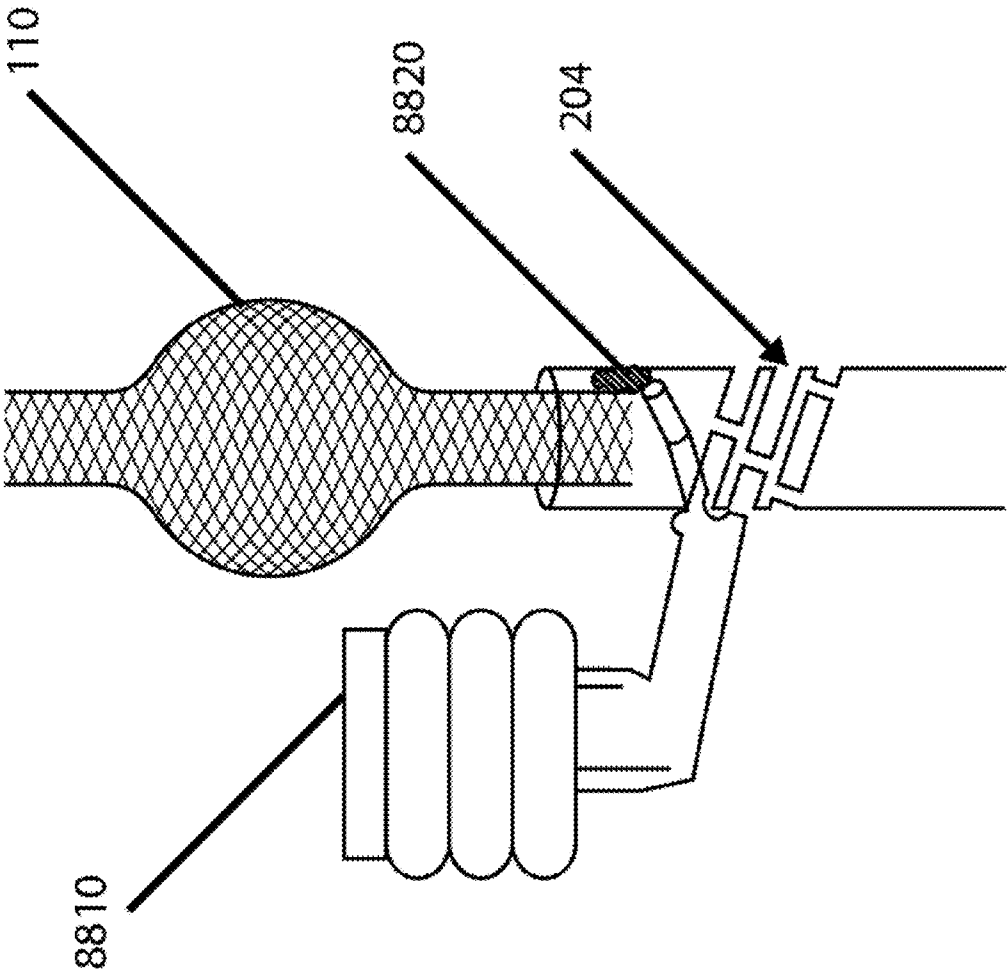


Fig. 20E

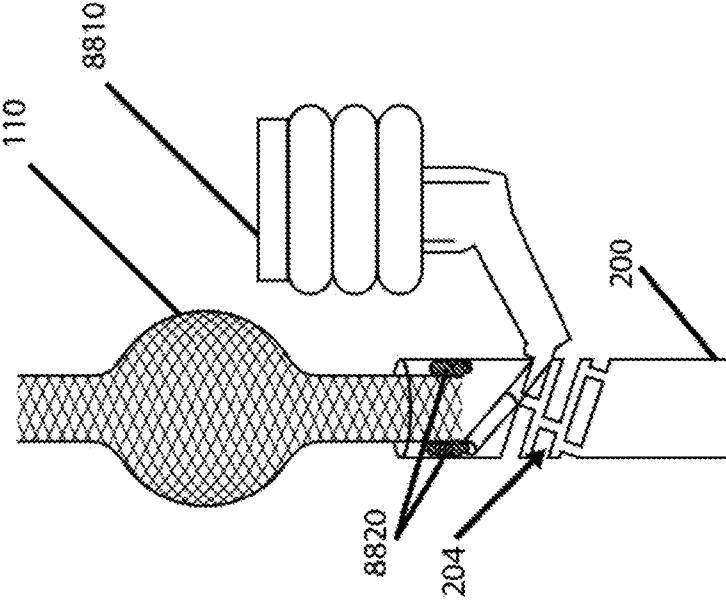


Fig. 20F

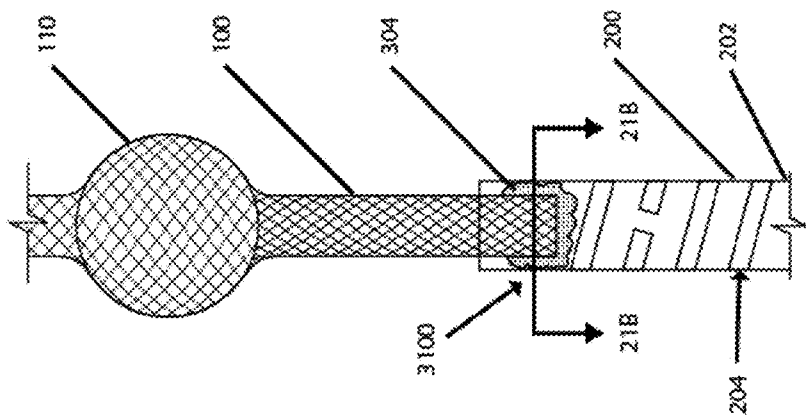


Fig. 21A

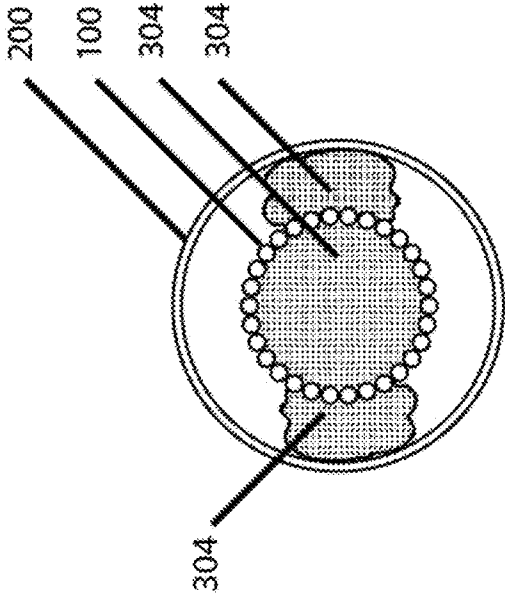


Fig. 21B

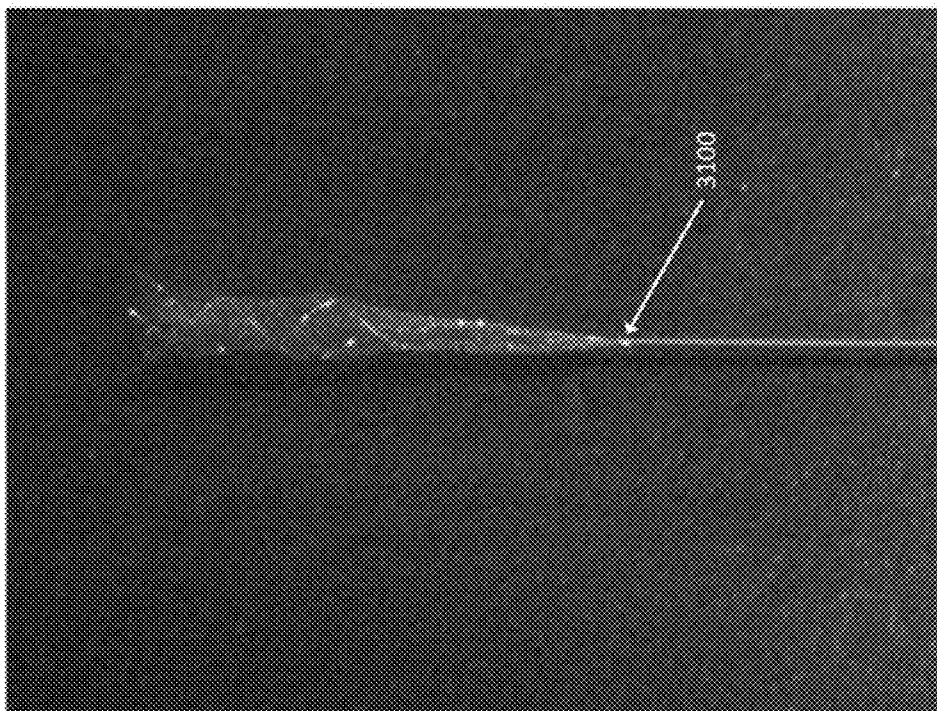


Fig. 21C

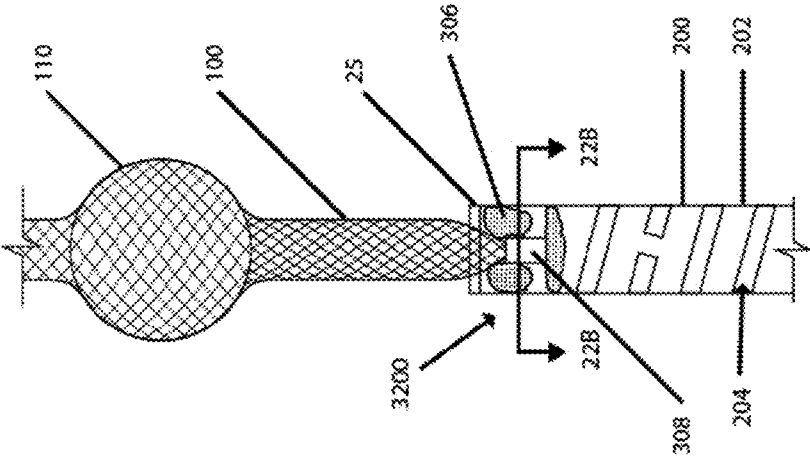


Fig. 22A



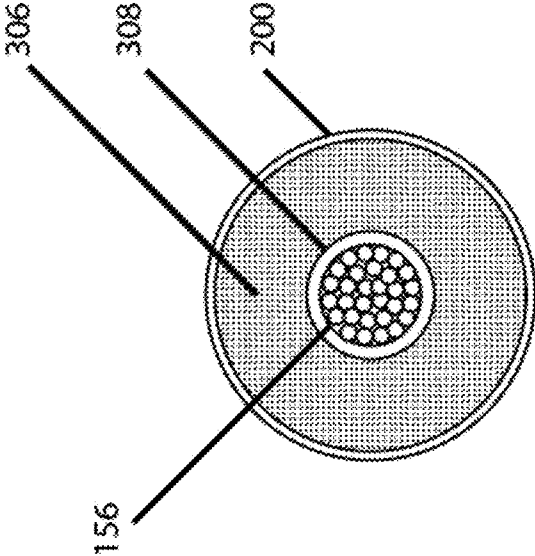


Fig. 22B

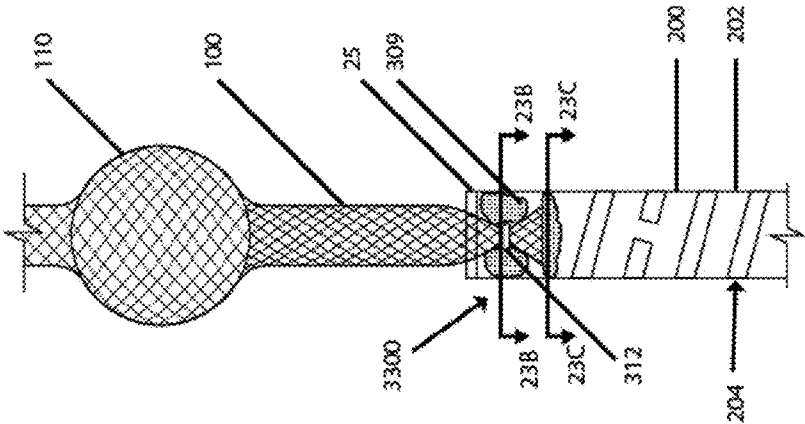


Fig. 23A

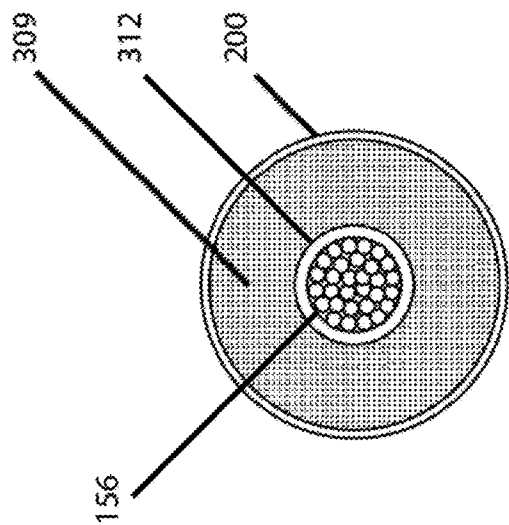


Fig. 23B

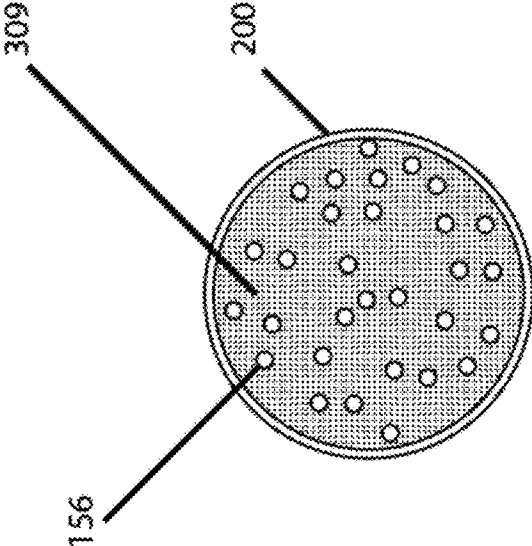


Fig. 23C

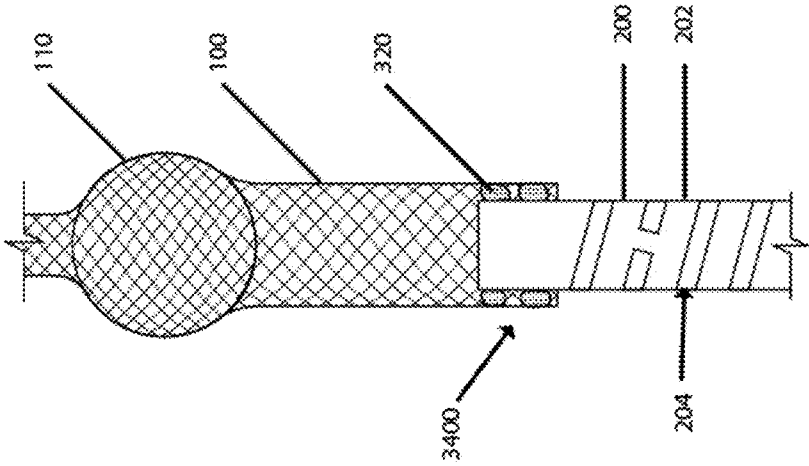


Fig. 24A

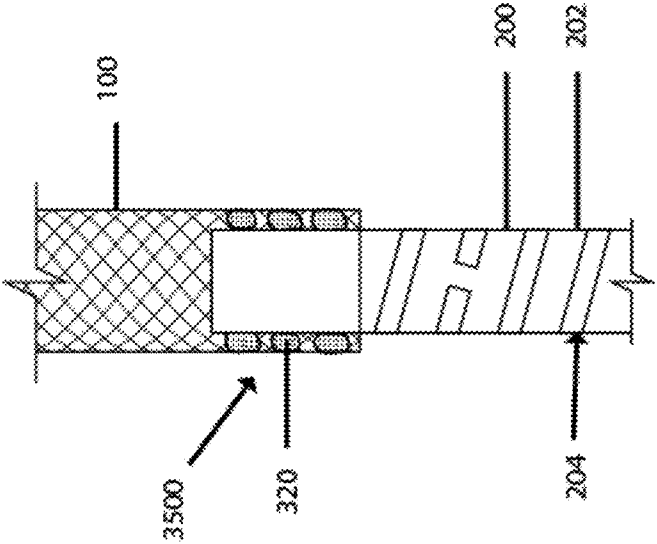


Fig. 24B

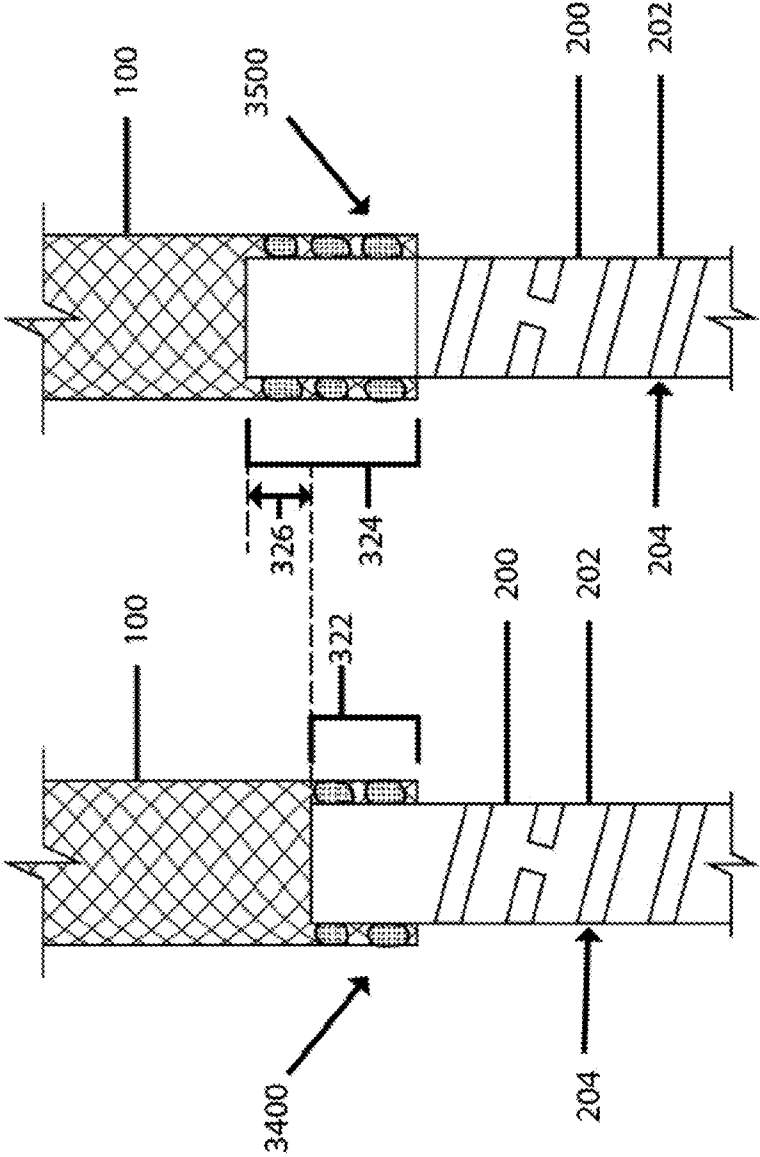


Fig. 24C

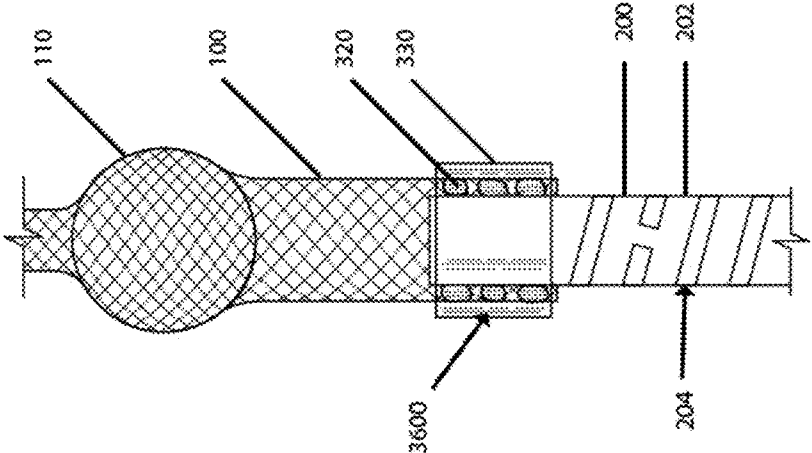


Fig. 24D



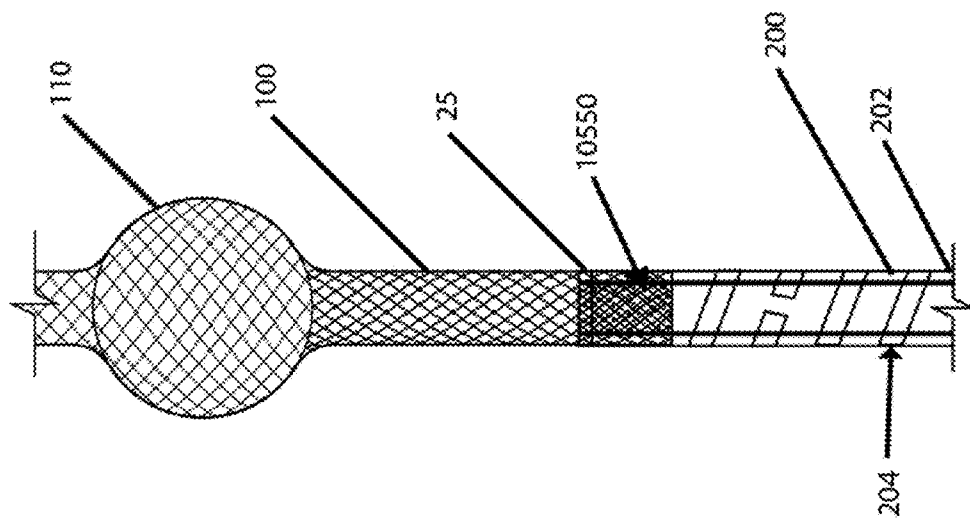


Fig. 25A-1

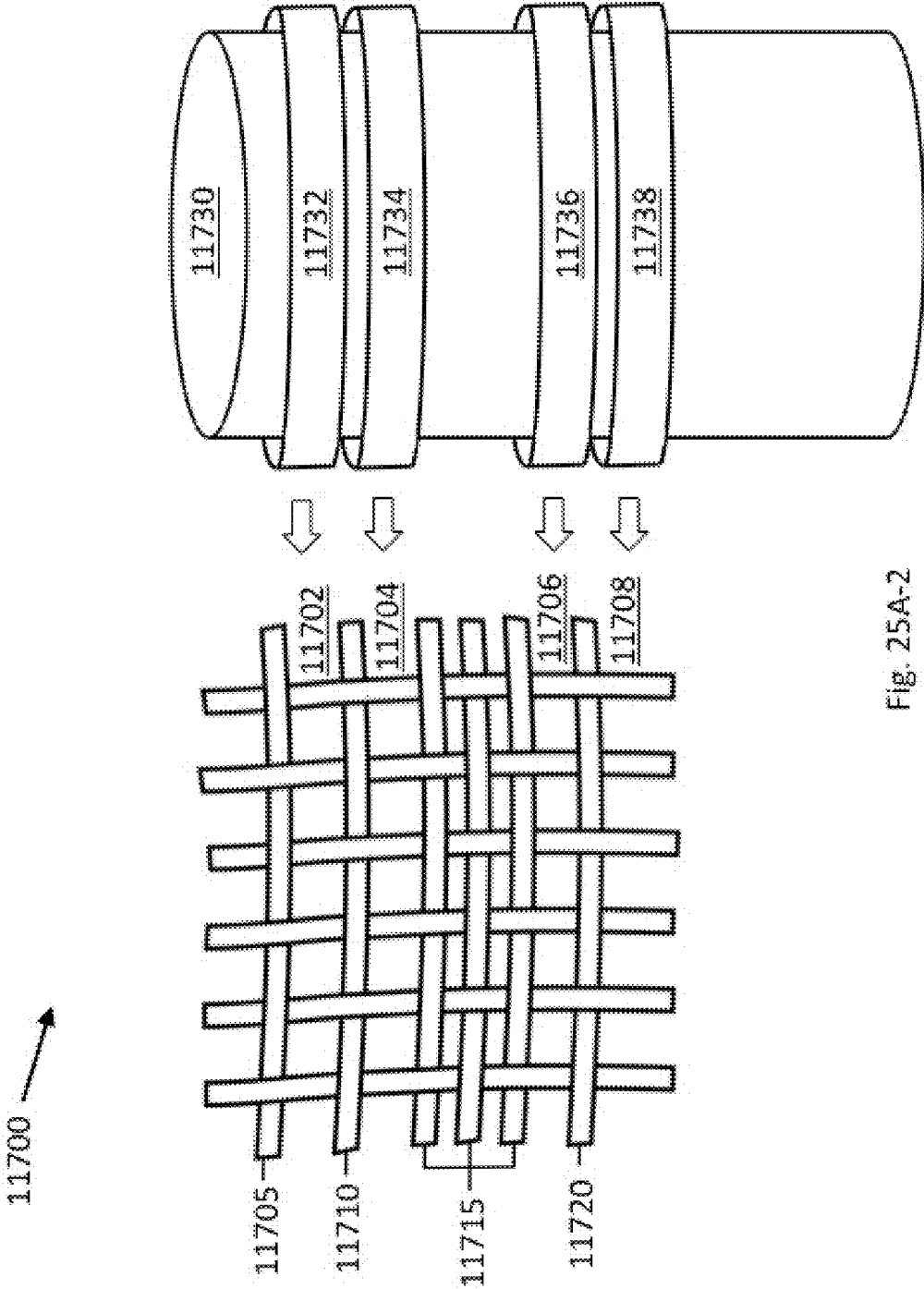


Fig. 25A-2

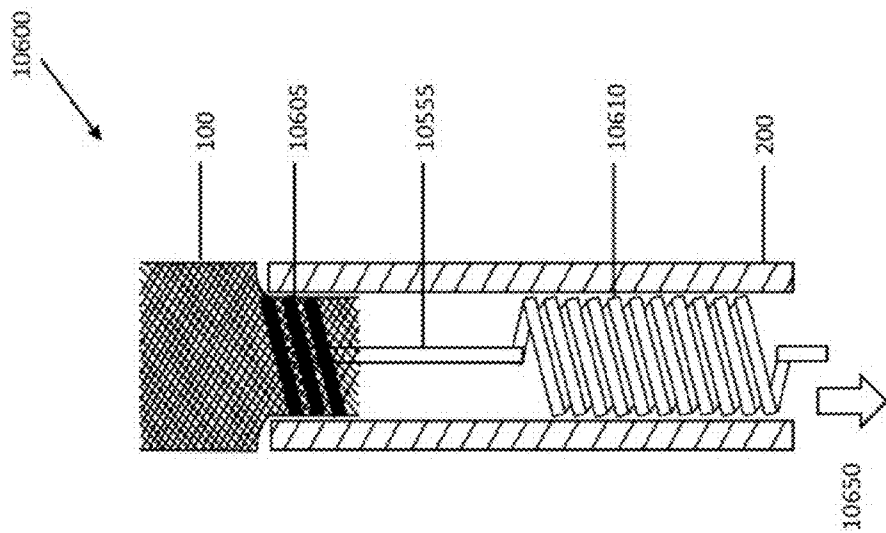


Fig. 25B

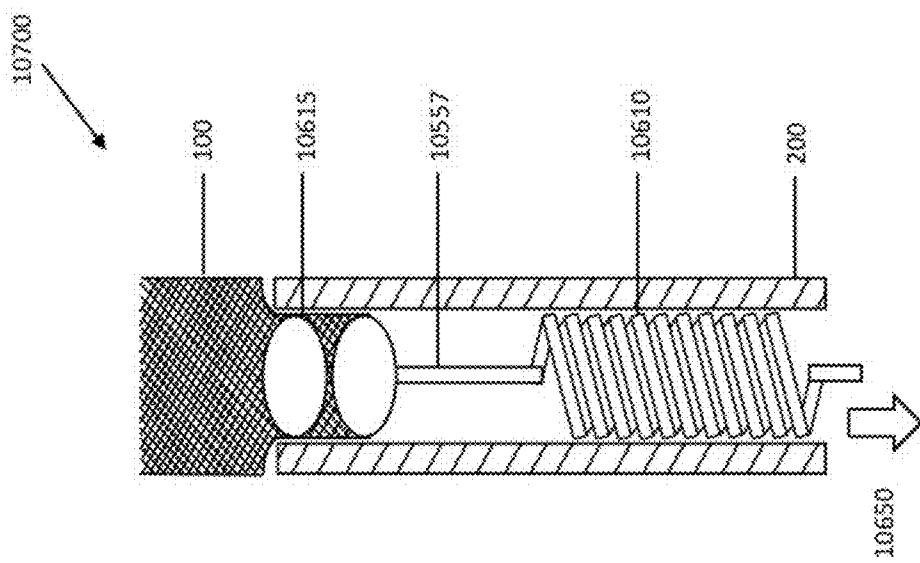


Fig. 25C

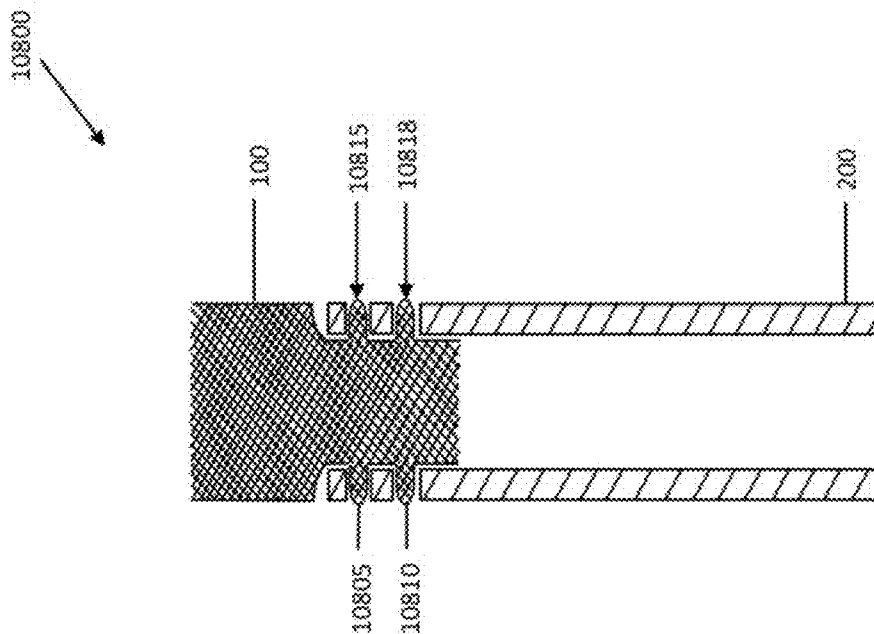


Fig. 25D

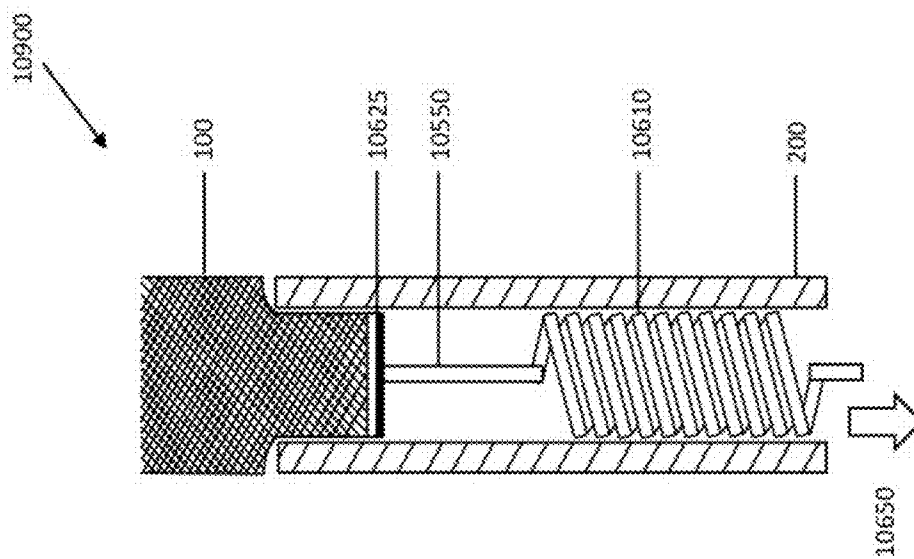


Fig. 25E

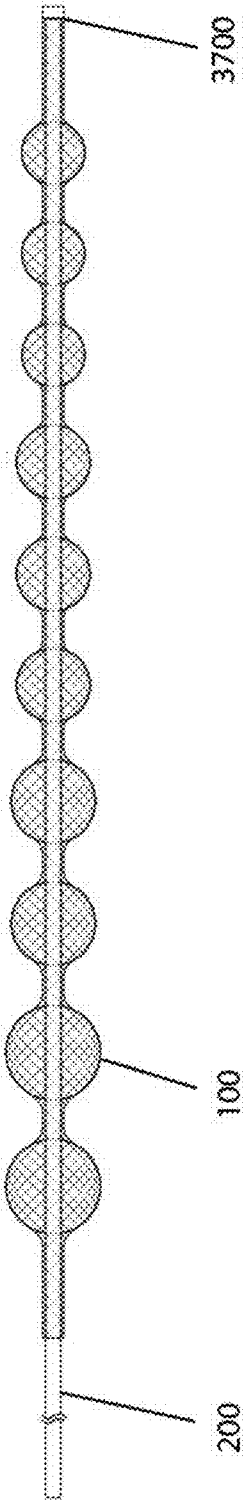


Fig. 26A

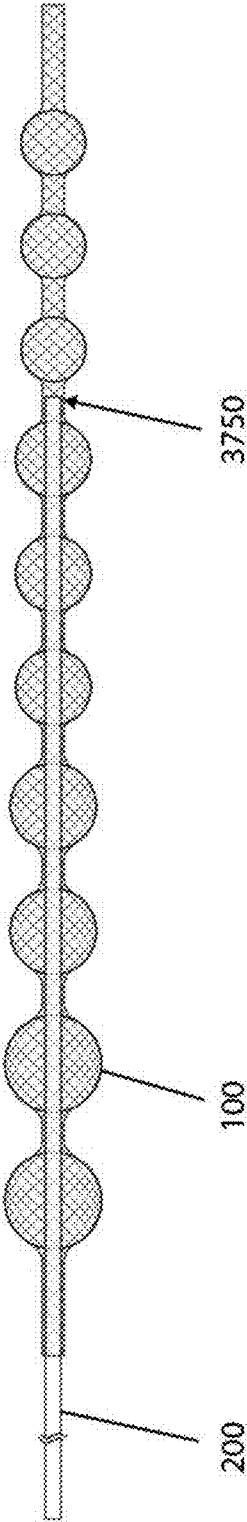


Fig. 26B



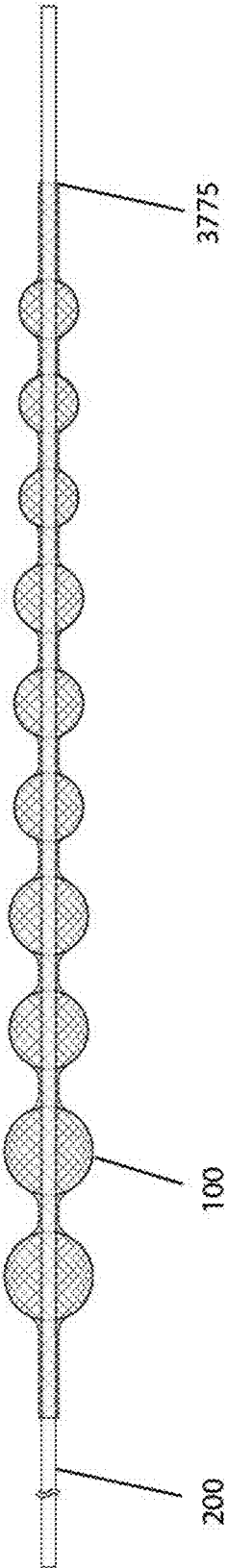


Fig. 26C

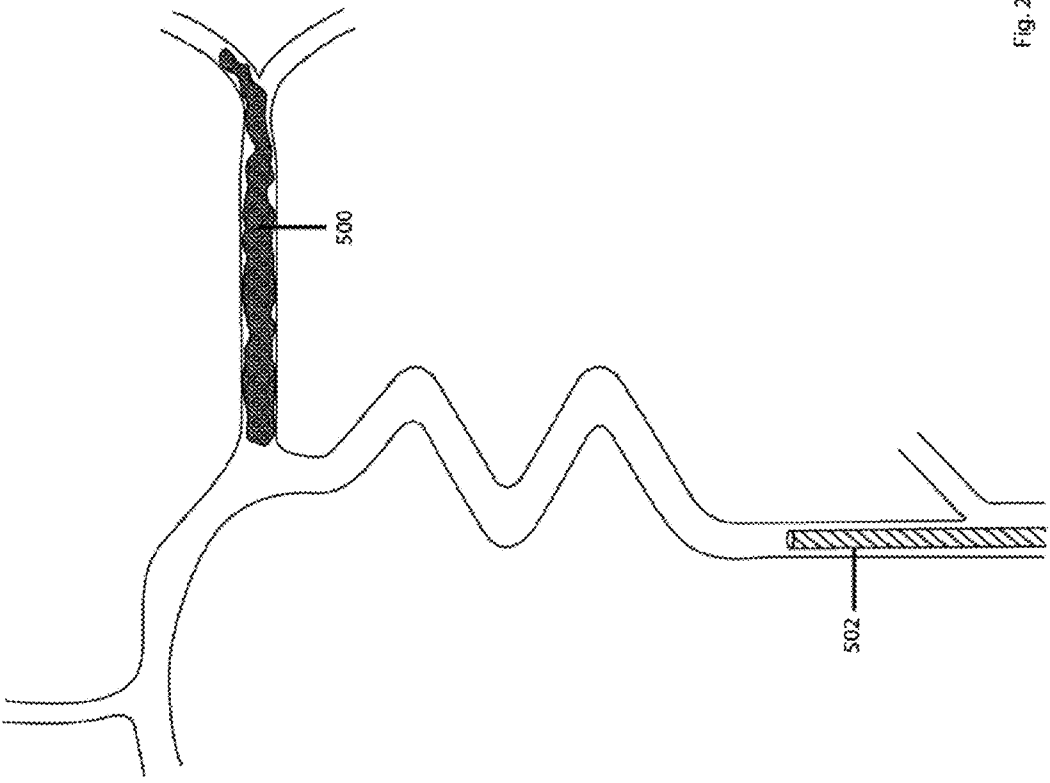


Fig. 27A

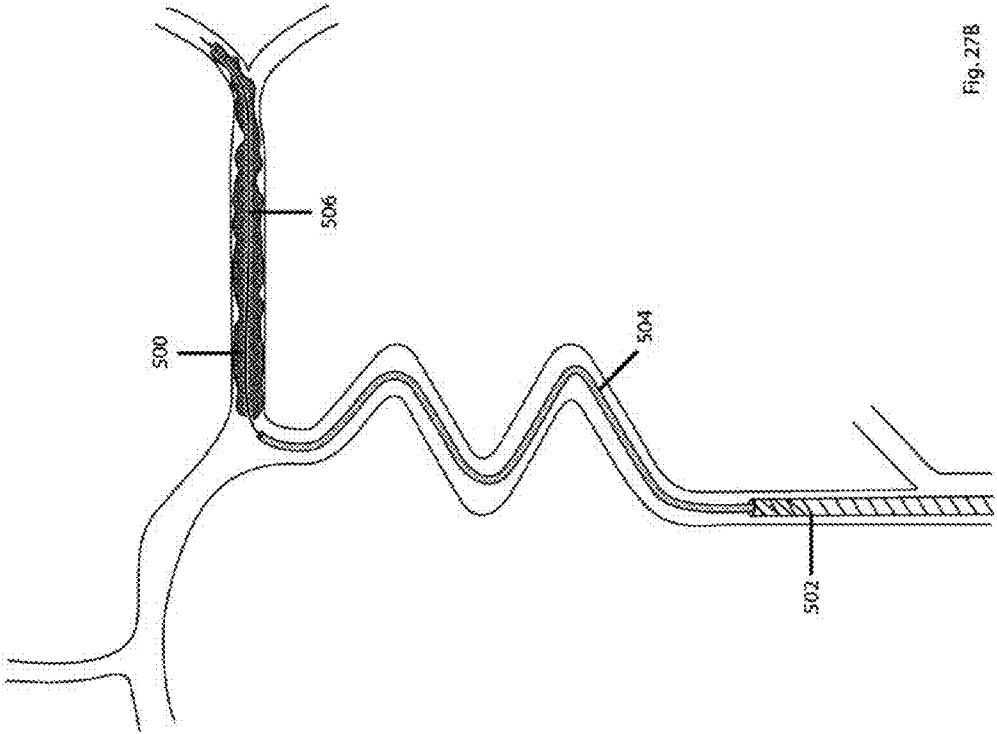


Fig. 27B

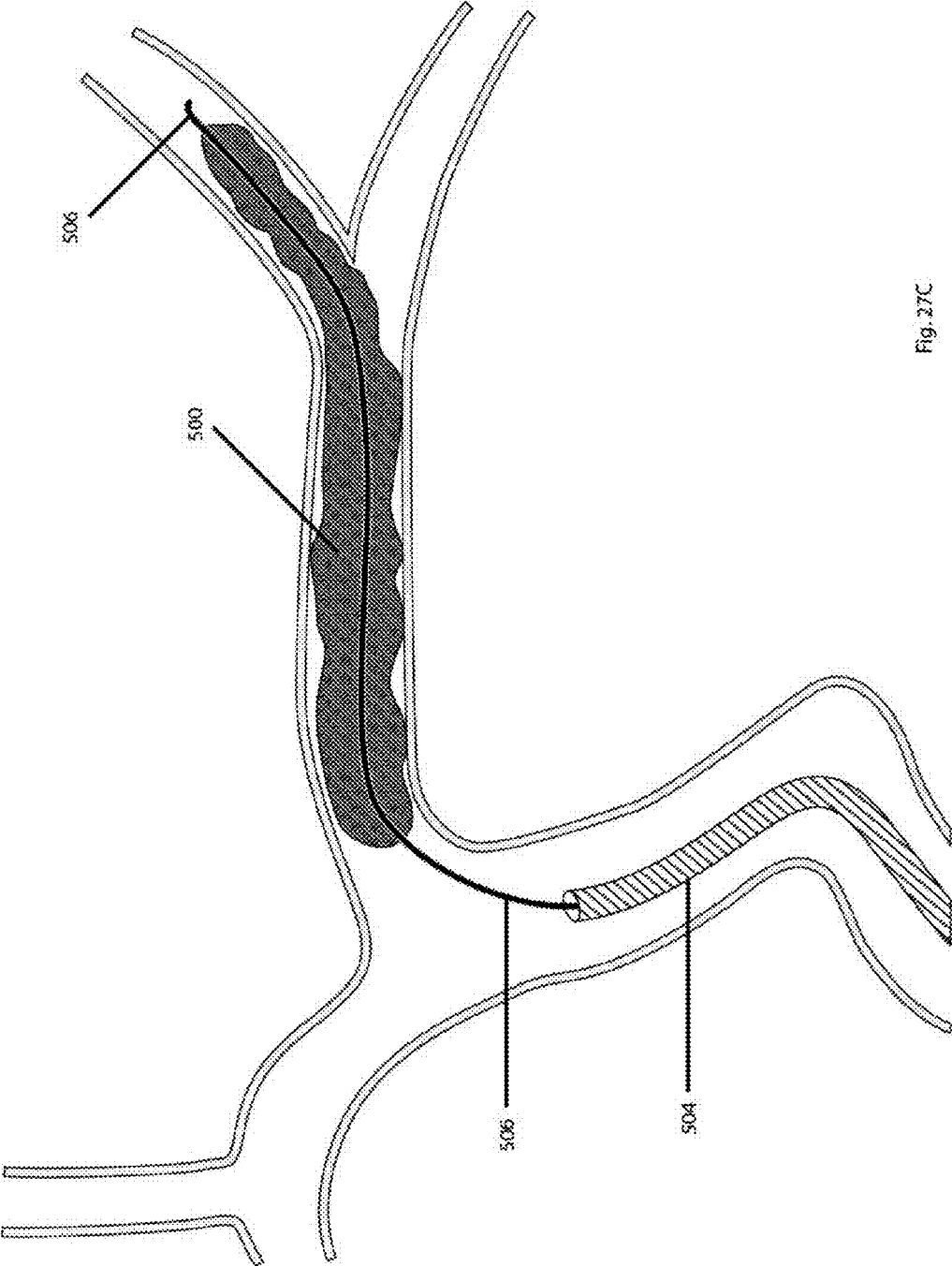


Fig. 27C

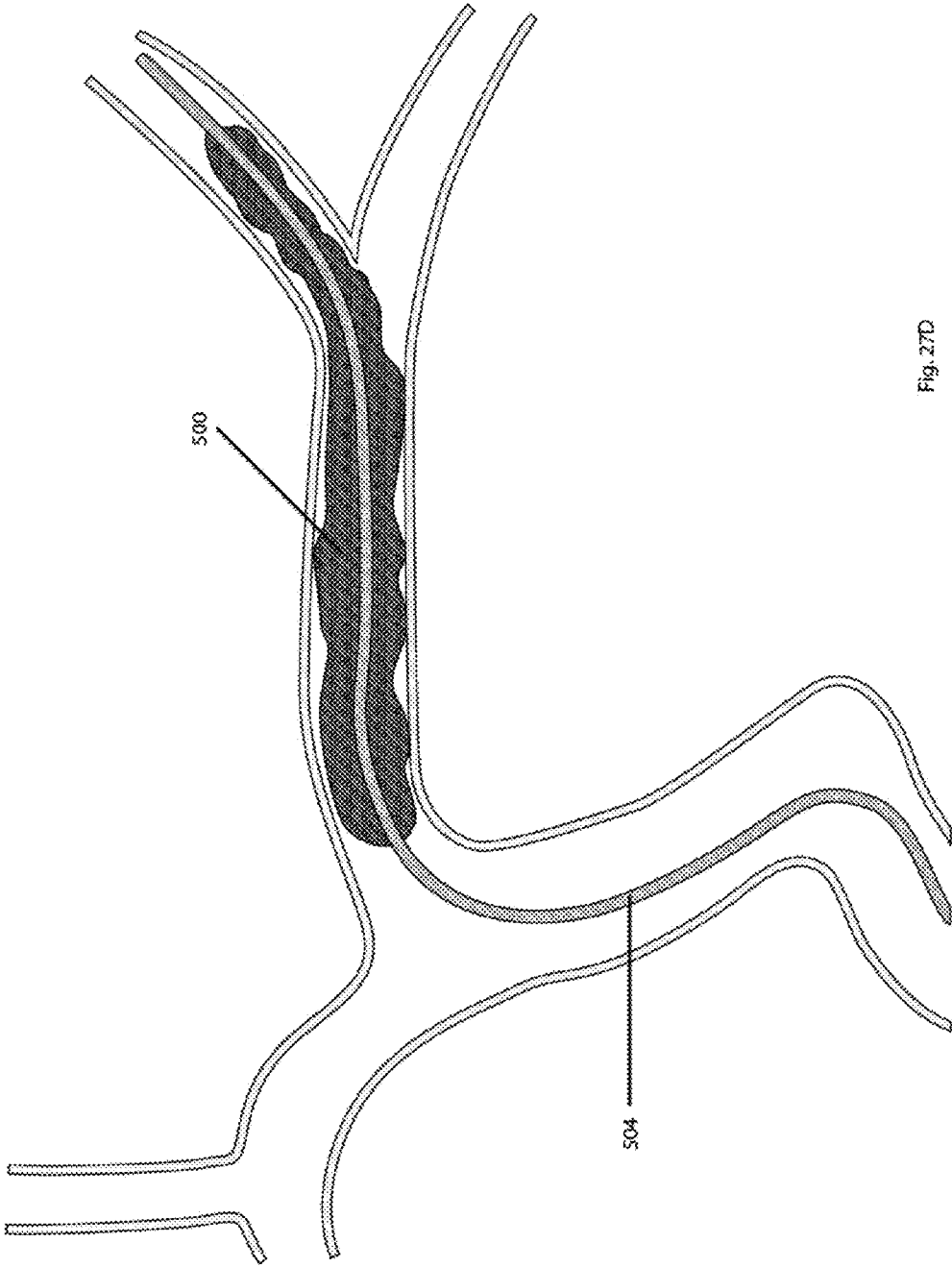


Fig. 27D

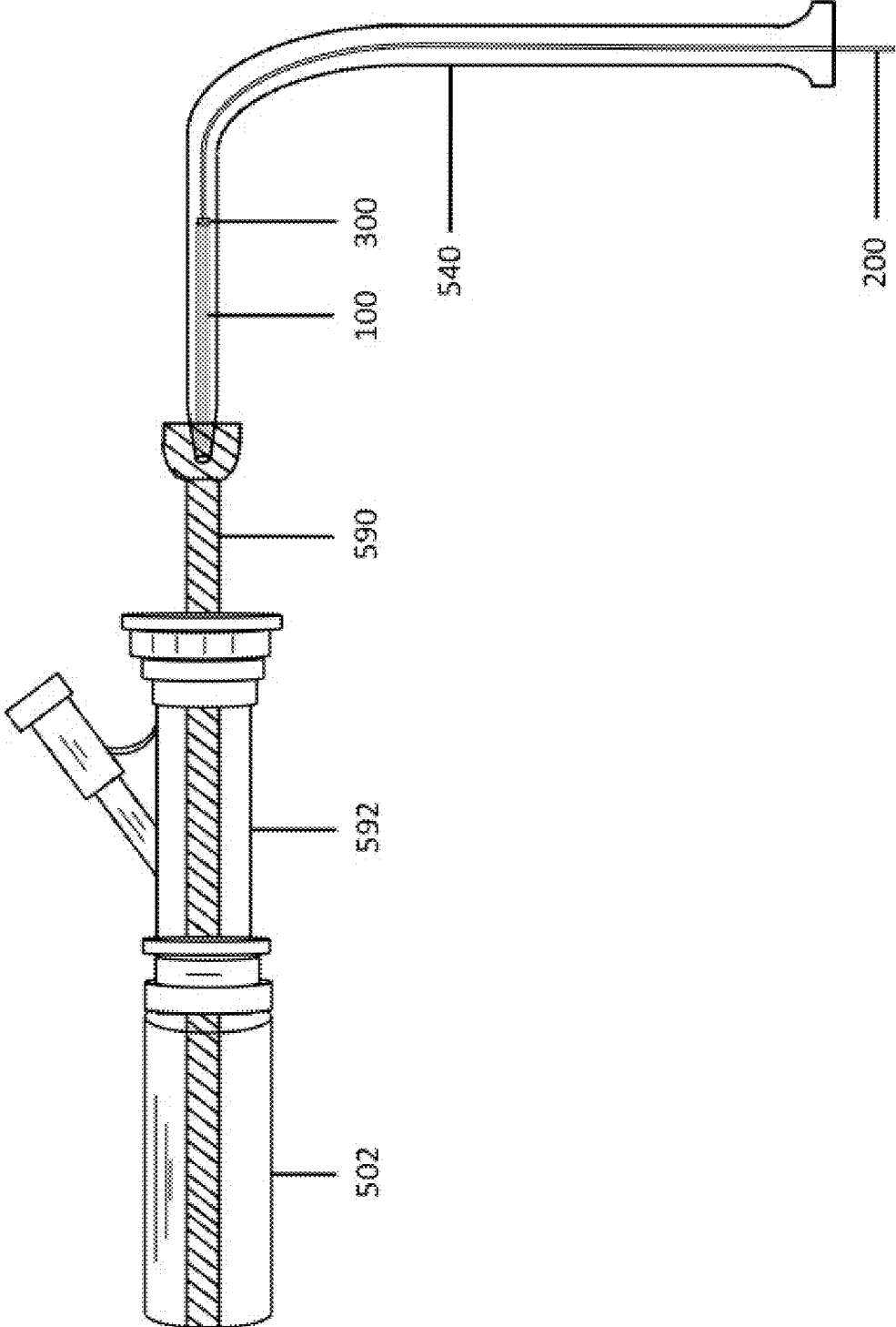


Fig. 27E

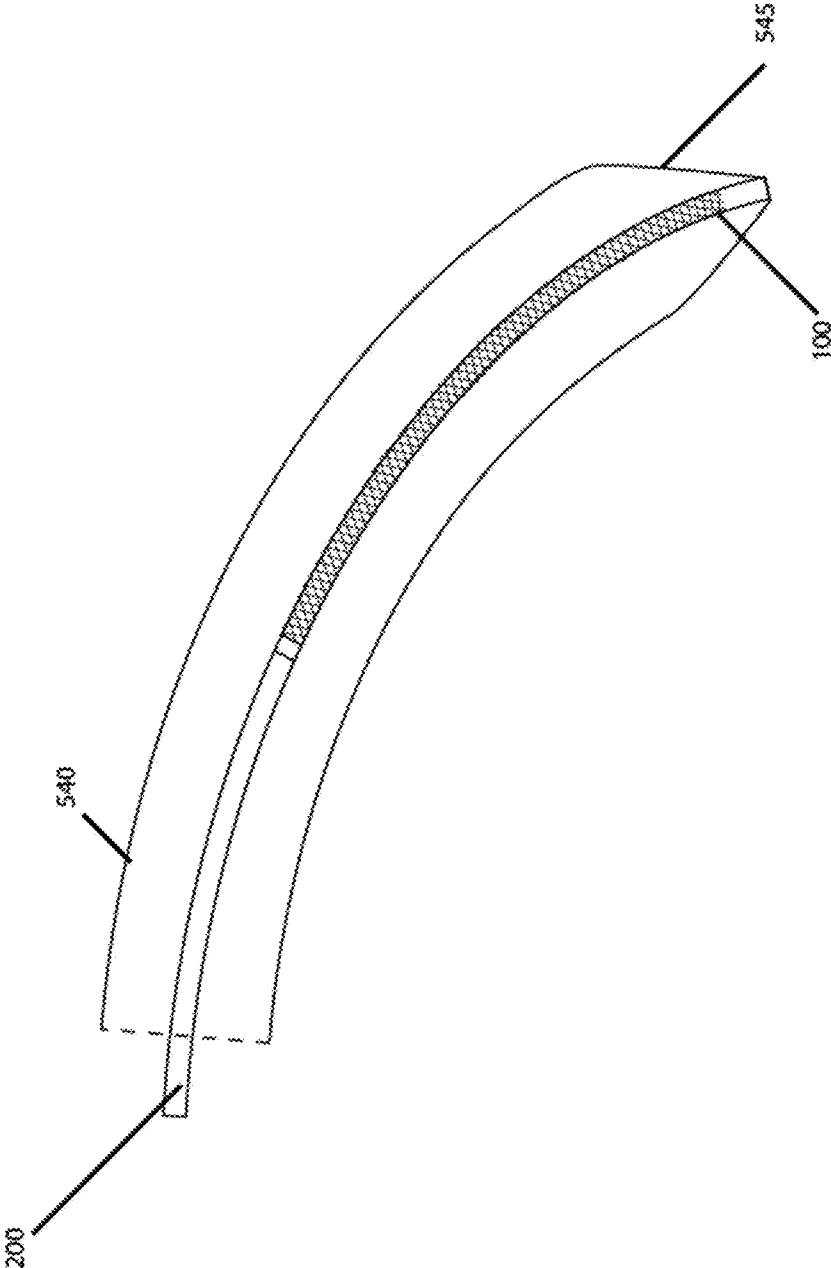


Fig. 27F

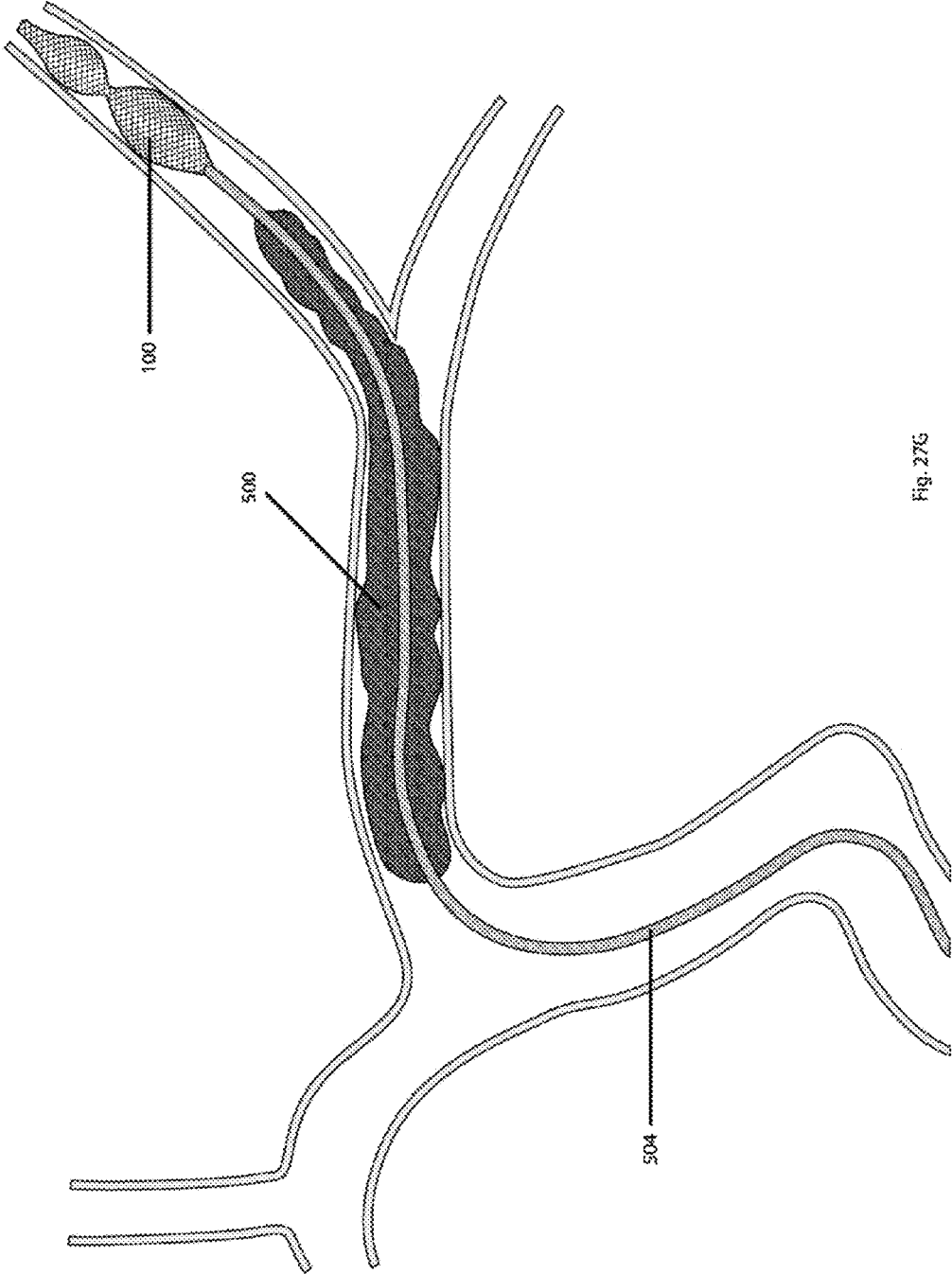


Fig. 27G



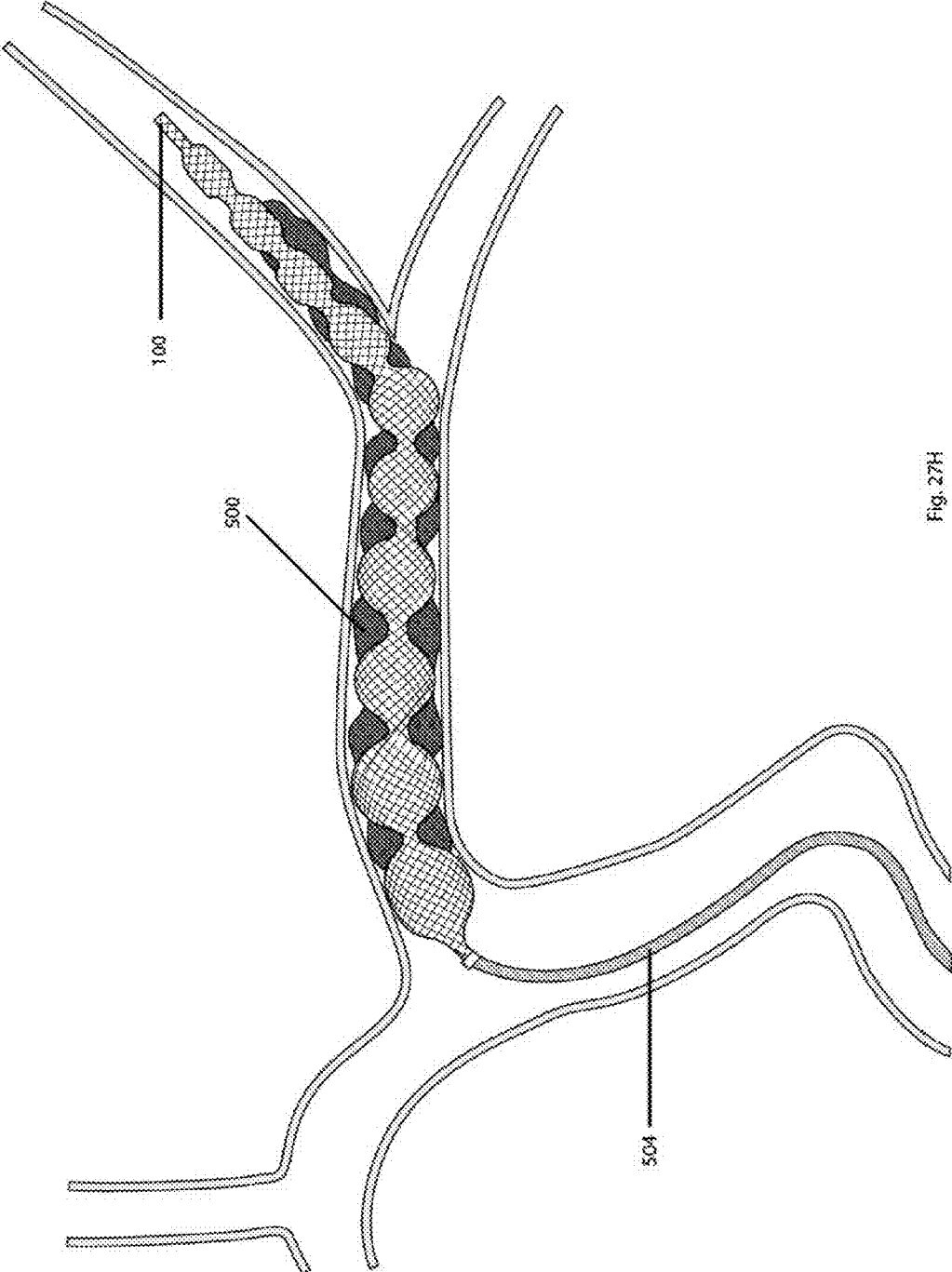


Fig. 27H

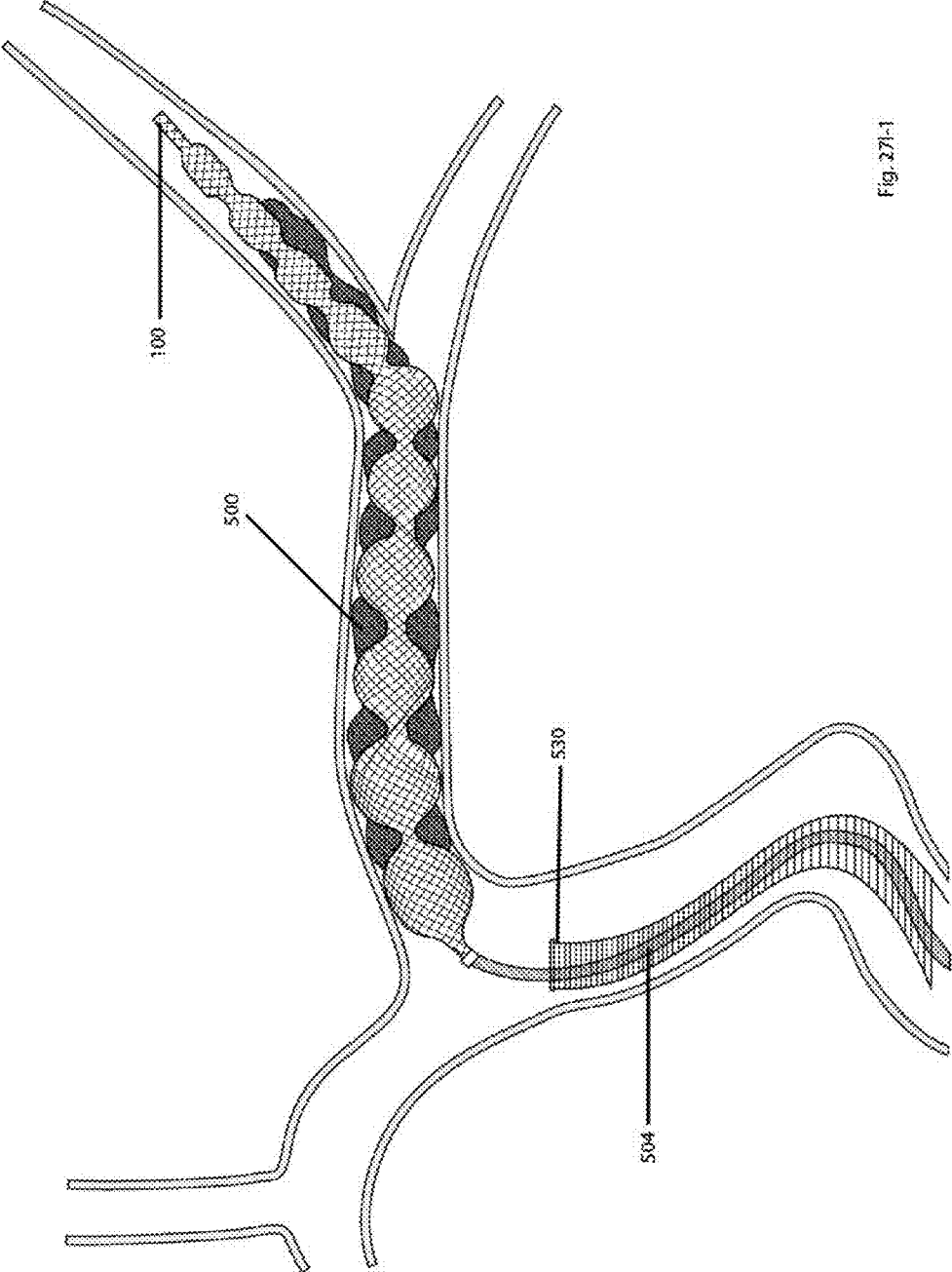


Fig. 271-1

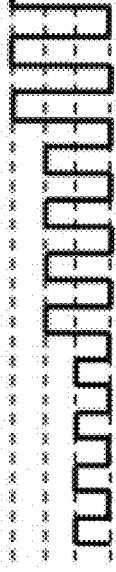

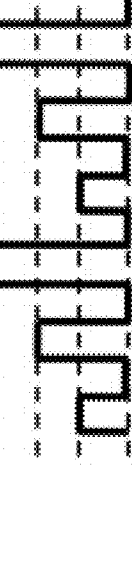

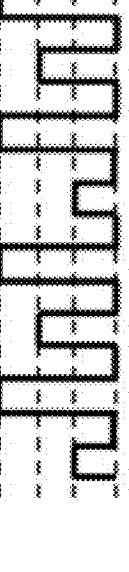
No.	Crescendo Suction Pattern	Graphical Representation
11800	<p>S. S. S. S. M. M. M.</p> <p>M. L. L. L. L.</p>	
11805	<p>S M L. S M L. S M L.</p>	
11810	<p>S. M. L. S. M. L.</p>	
11815	<p>S. L. S. L. S. L.</p>	
11820	<p>S. L. M. L. S. L. M. L.</p>	

Fig. 27I-2

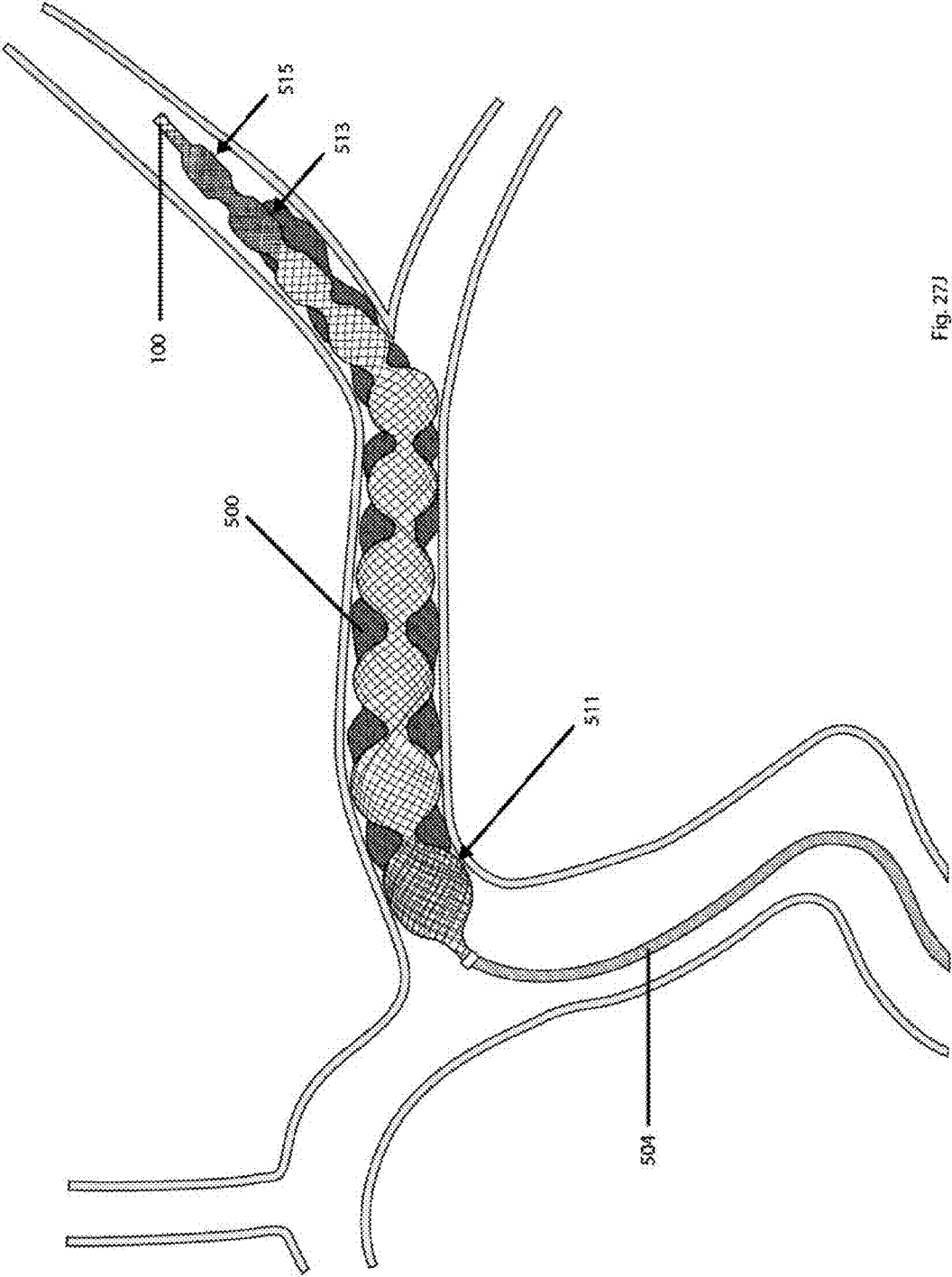


Fig. 27J

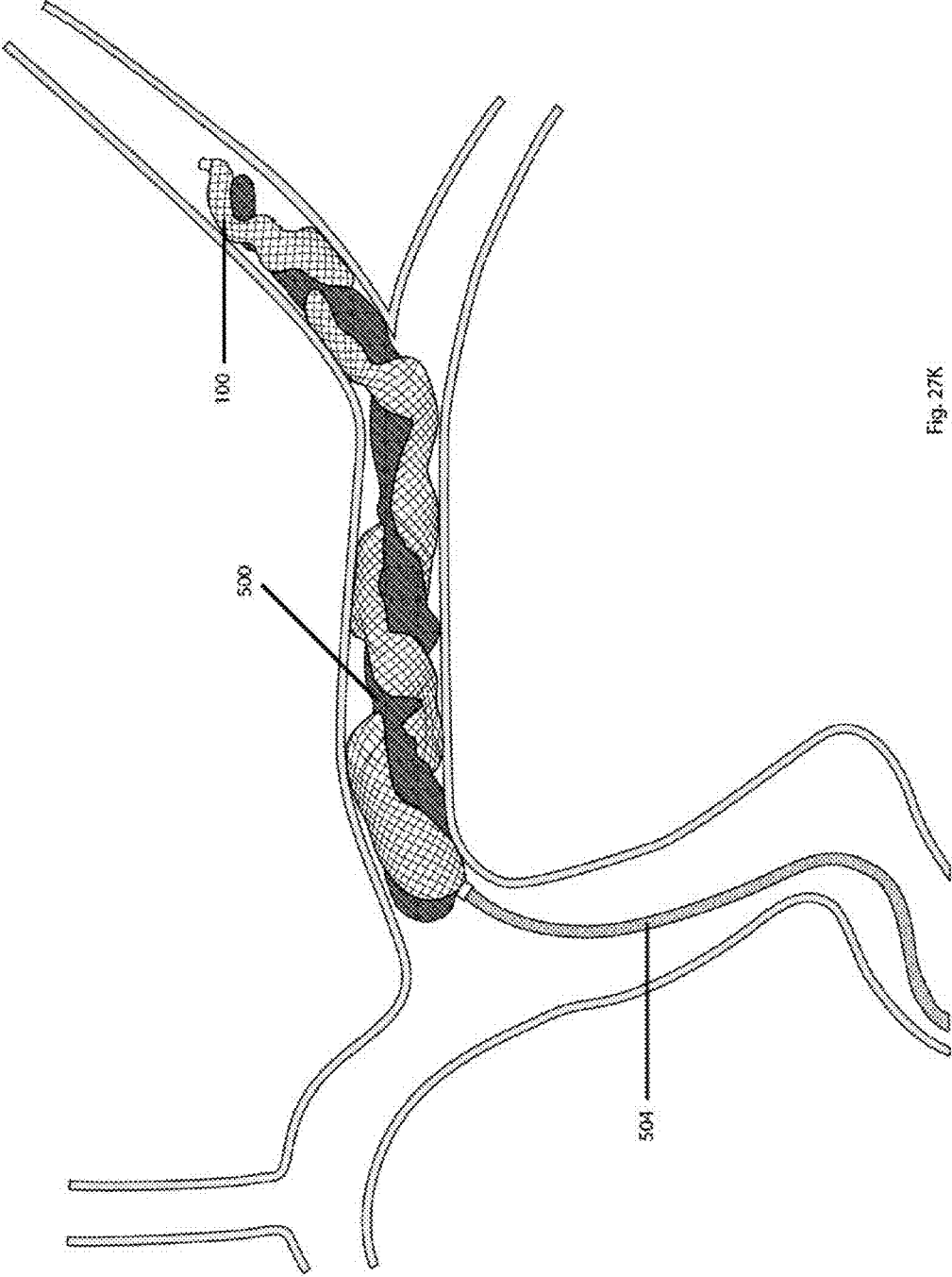


Fig. 27K

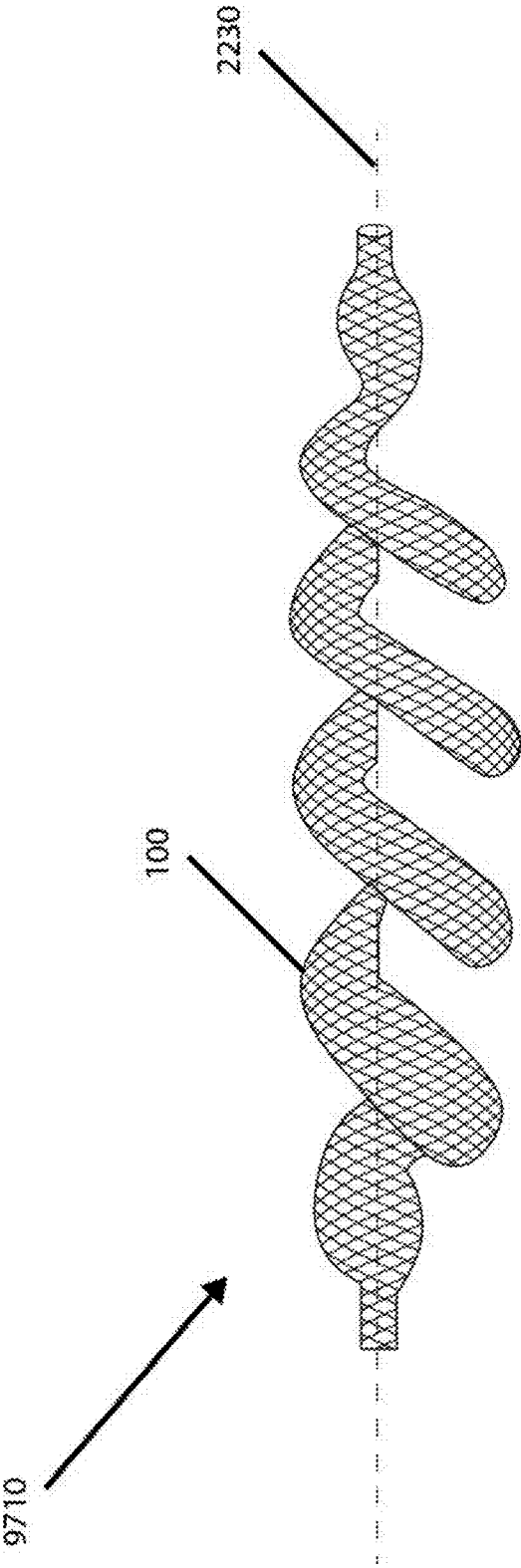


Fig. 27L

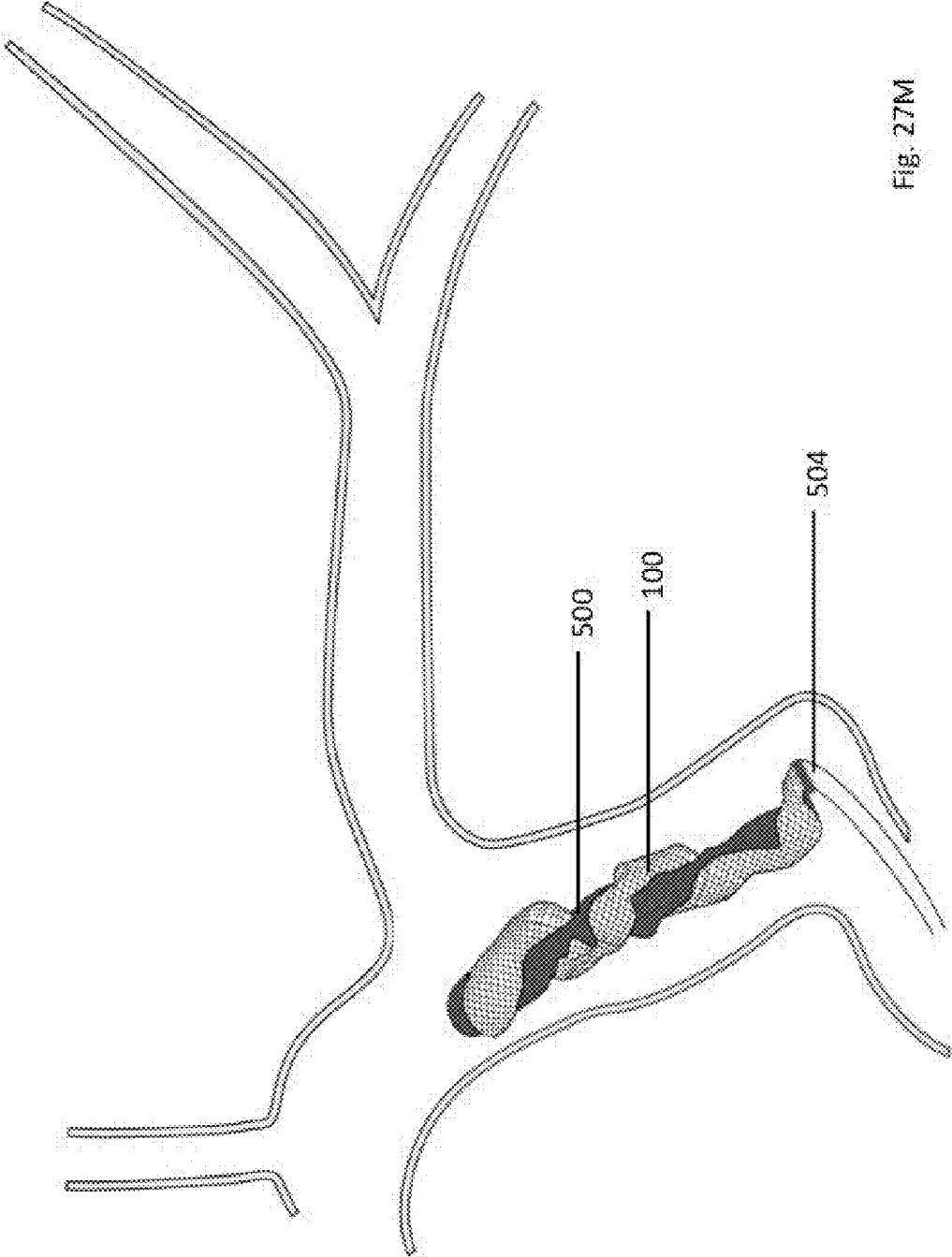


Fig. 27M

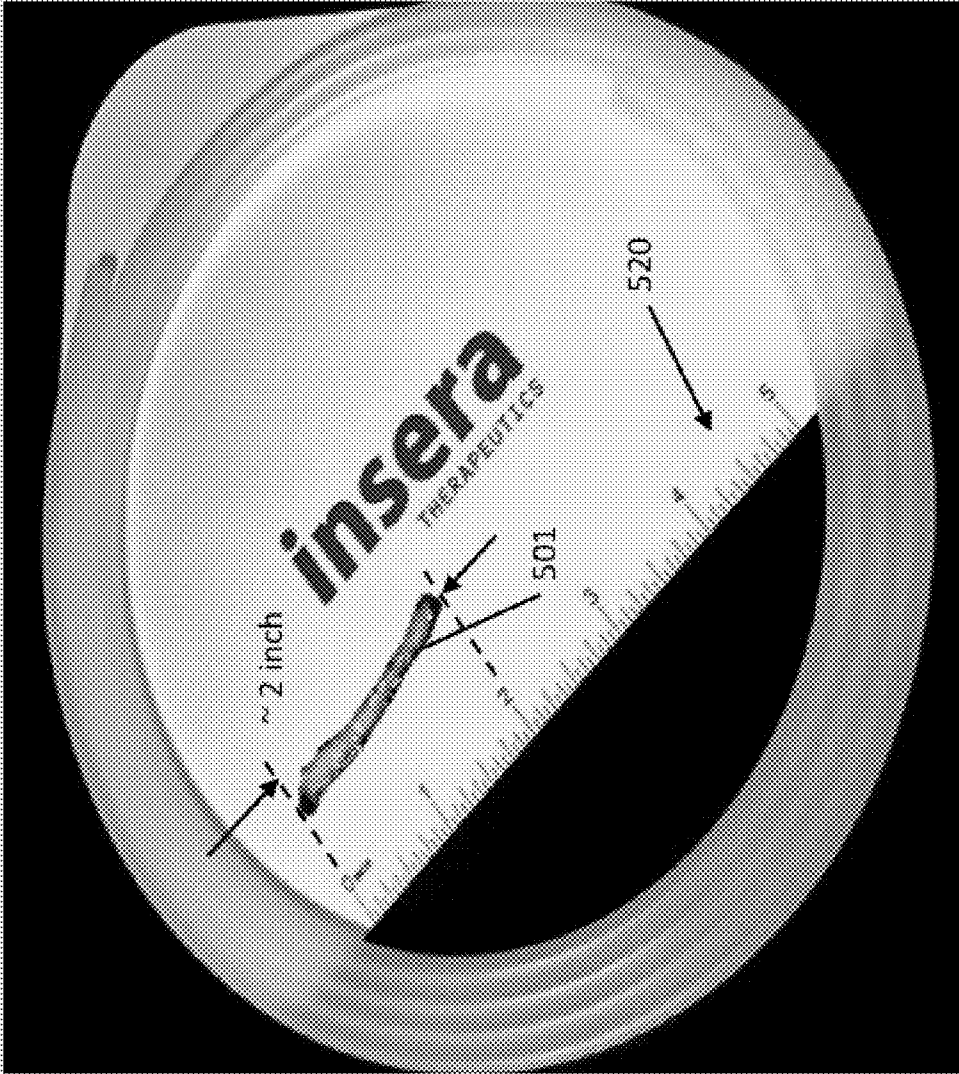


Fig. 27N



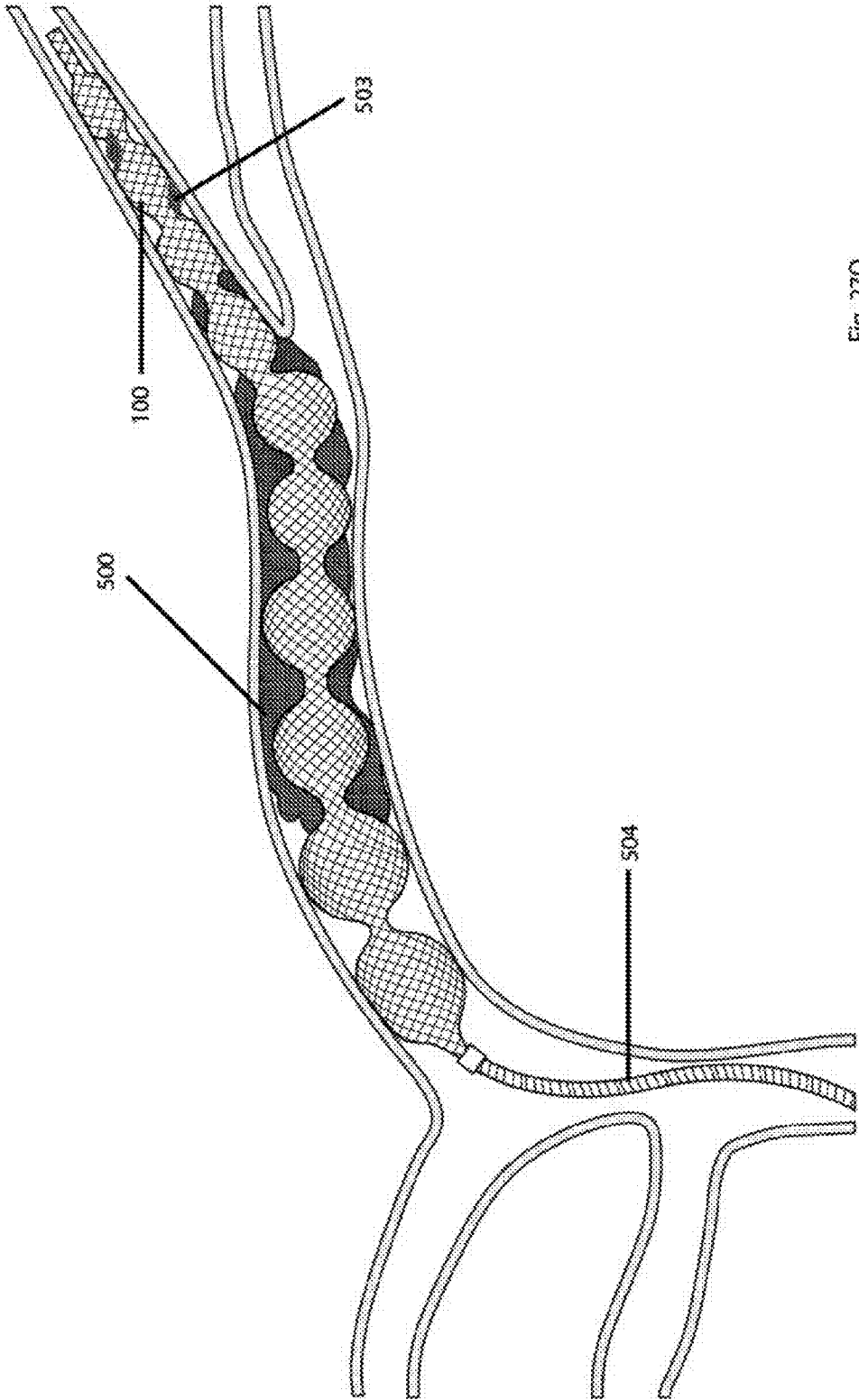


Fig. 270

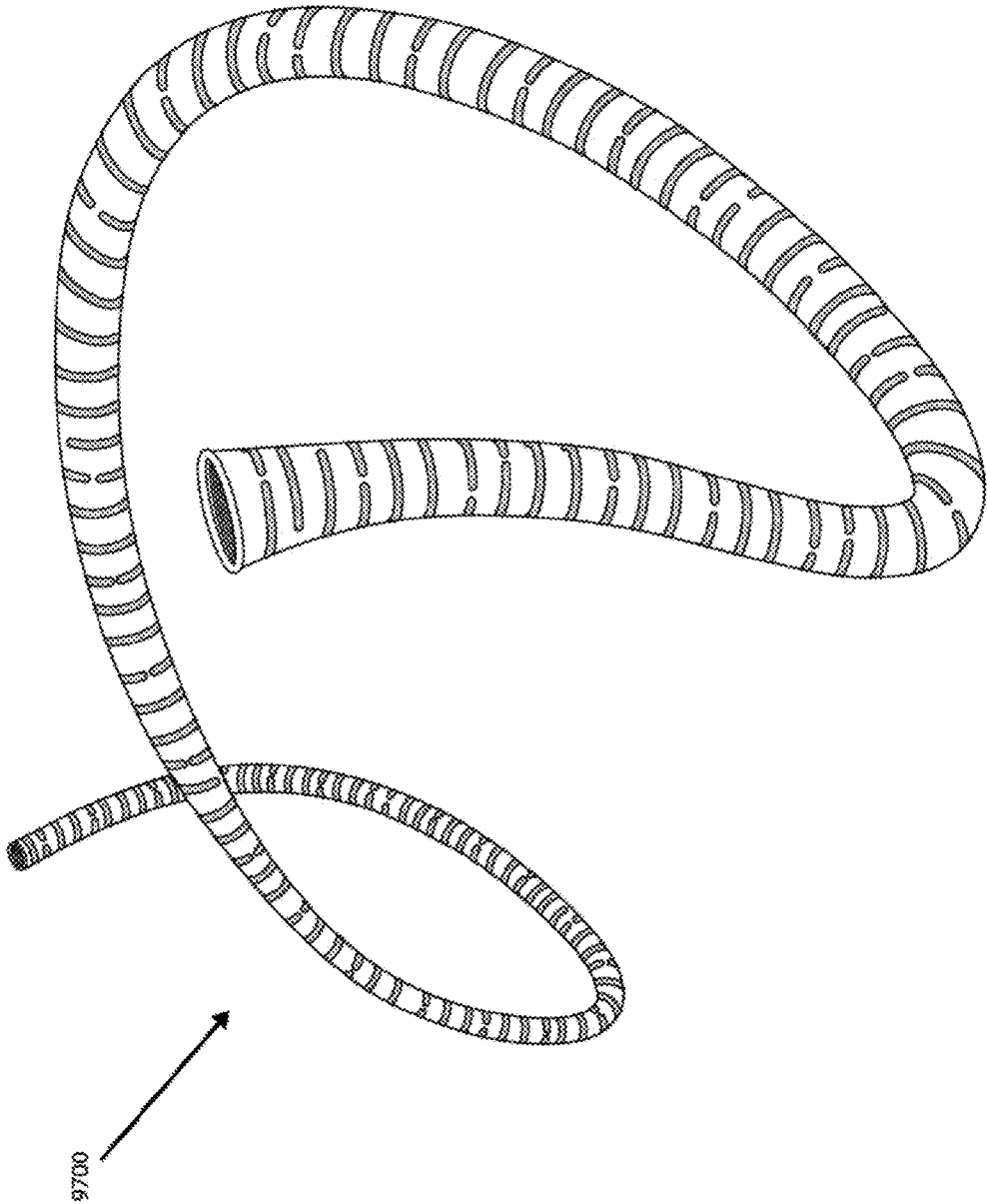


Fig. 27P

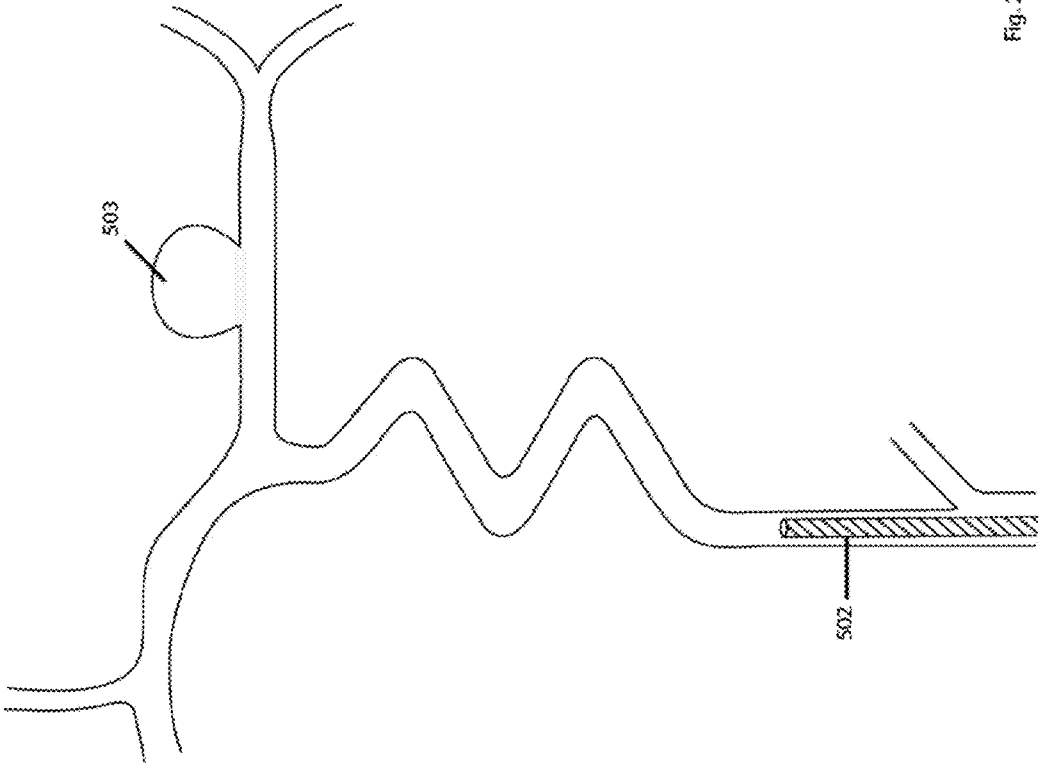


Fig. 28A

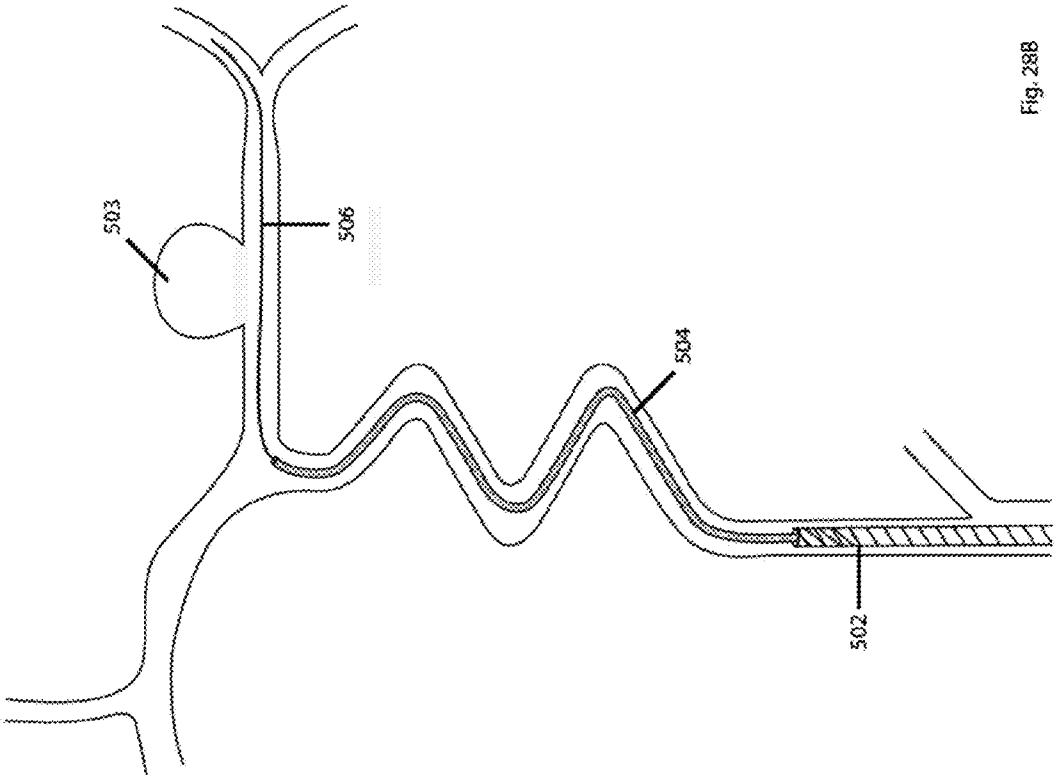


Fig. 28B

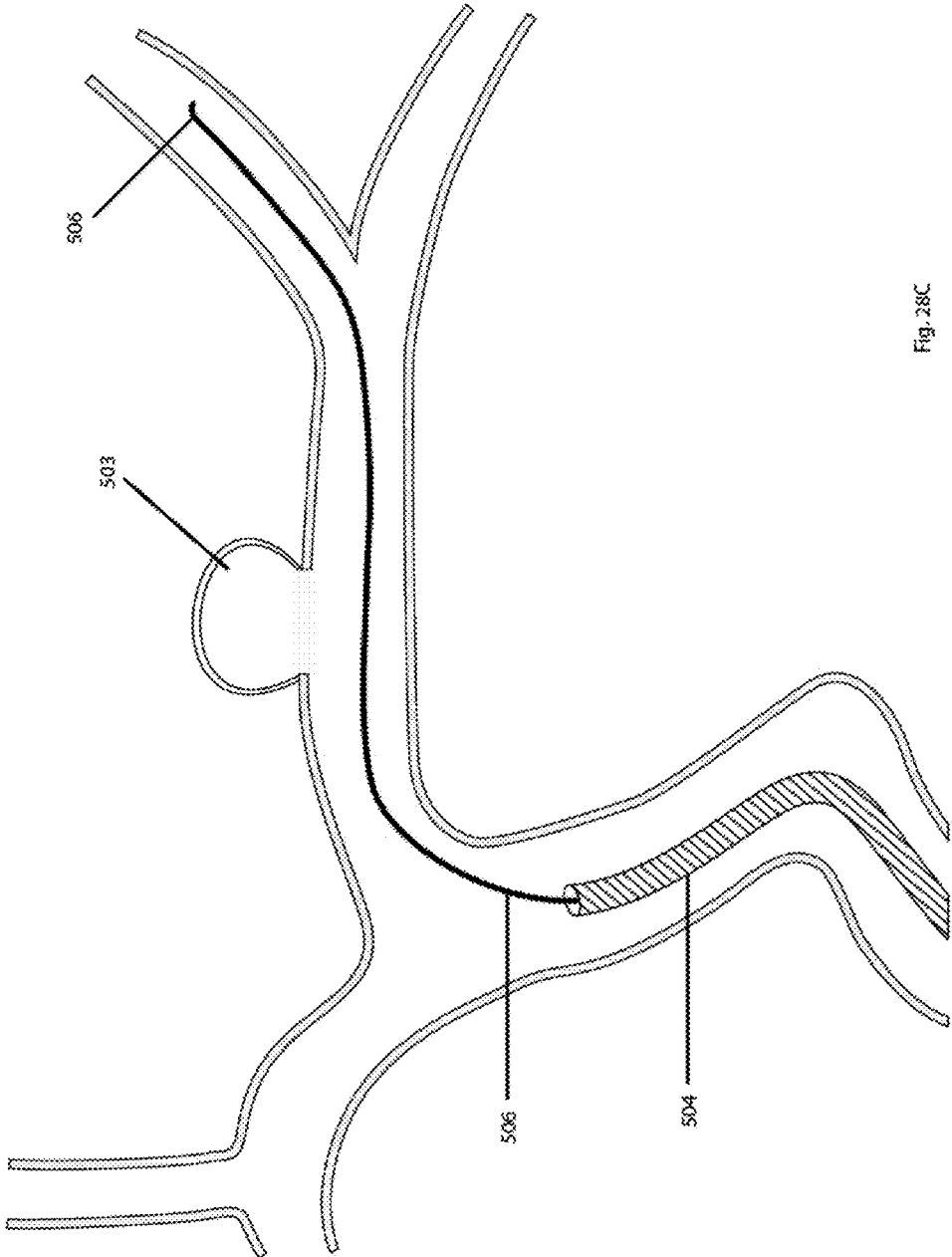


Fig. 28C

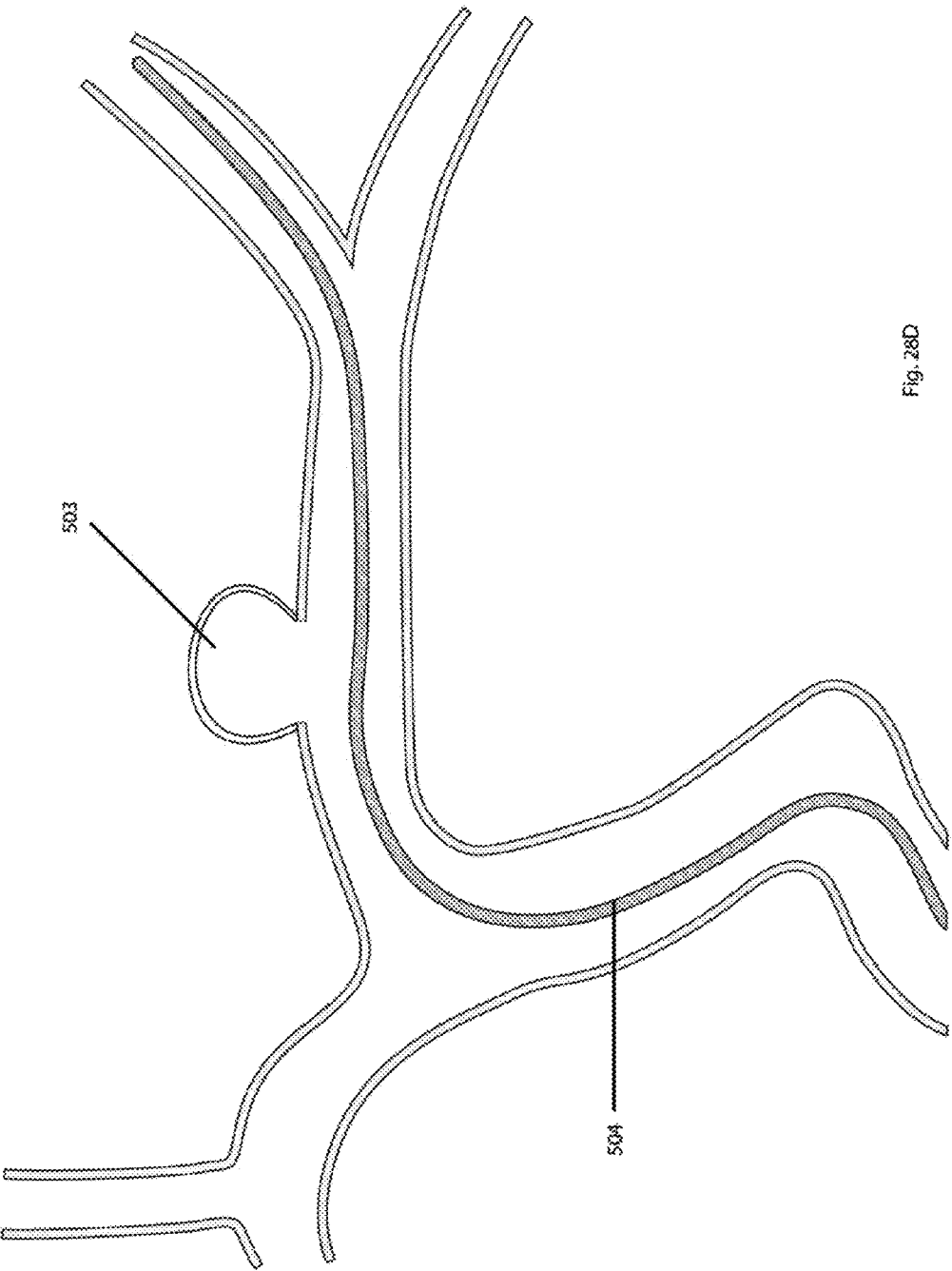


Fig. 28D

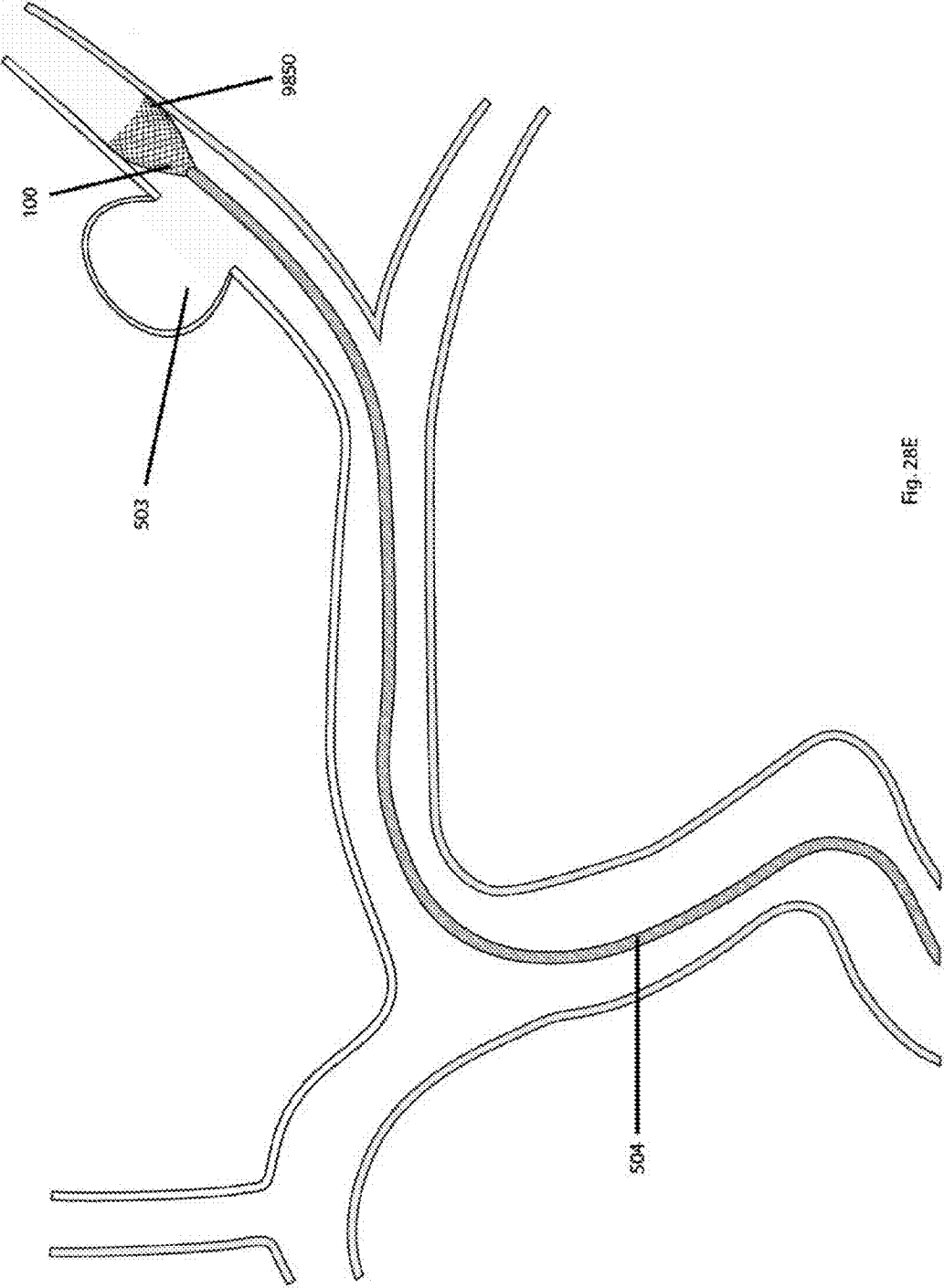


Fig. 28E

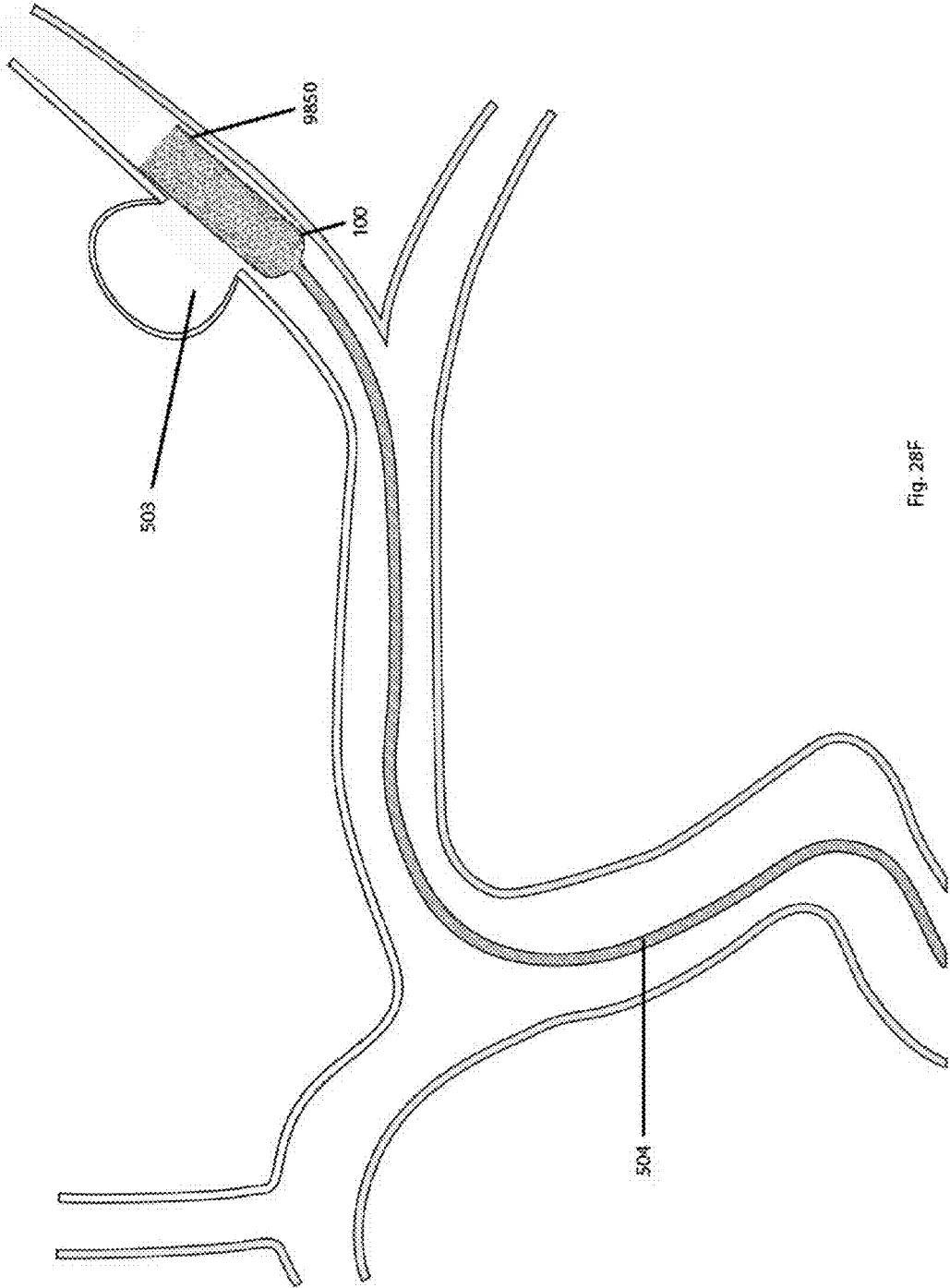


Fig. 28F



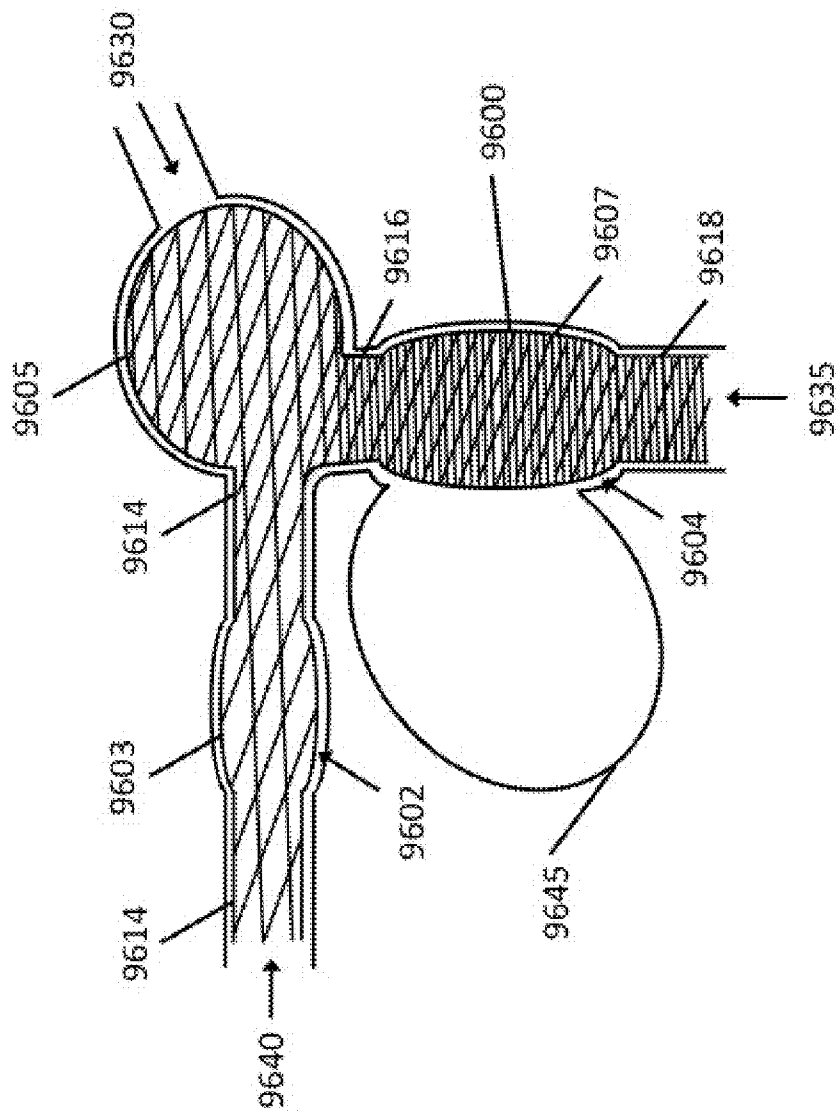


Fig. 28G

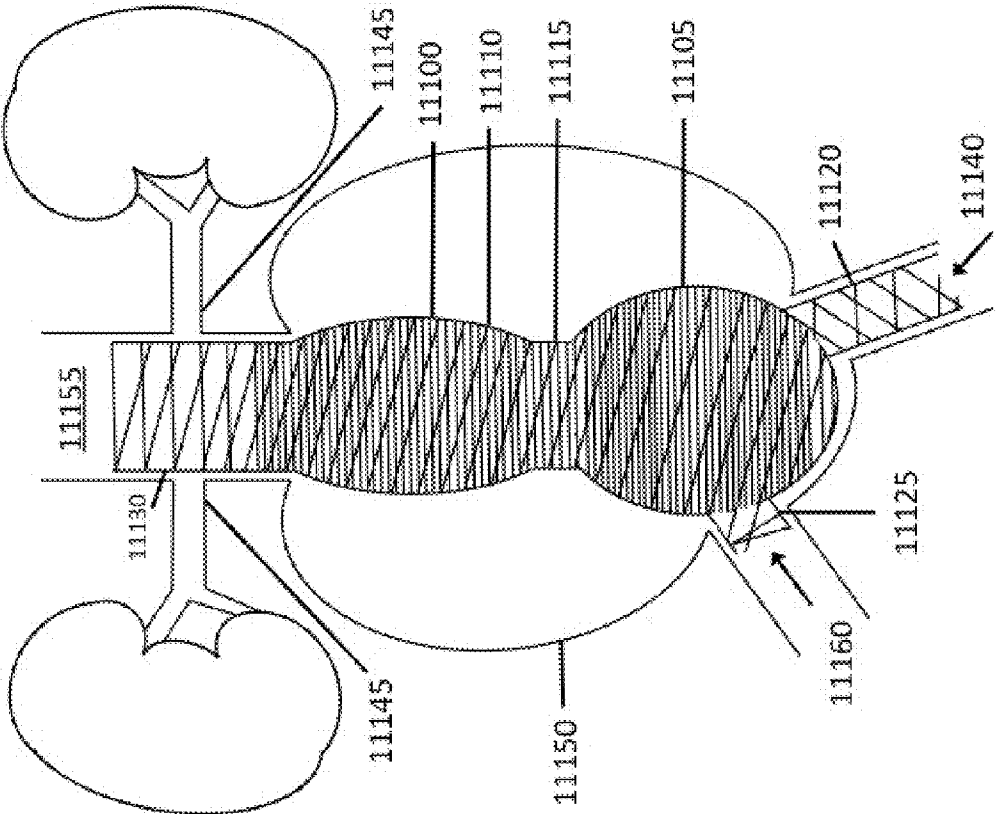


Fig. 28H

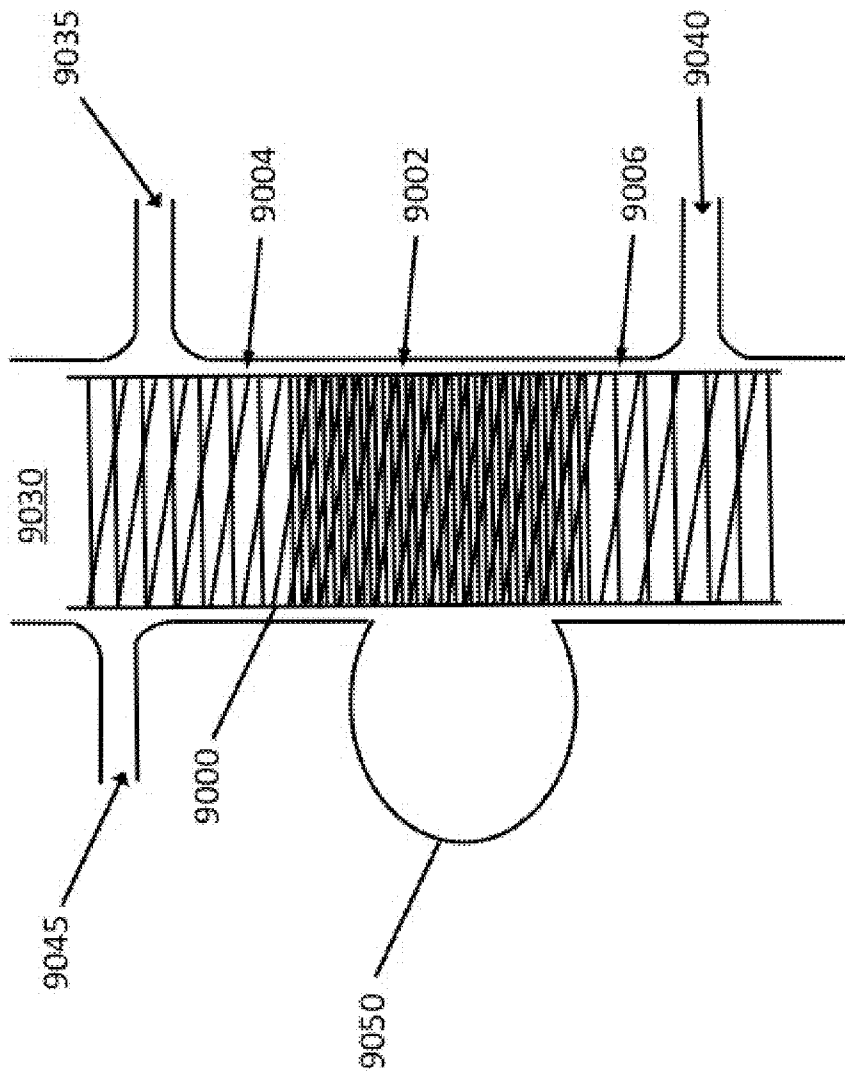


Fig. 28f

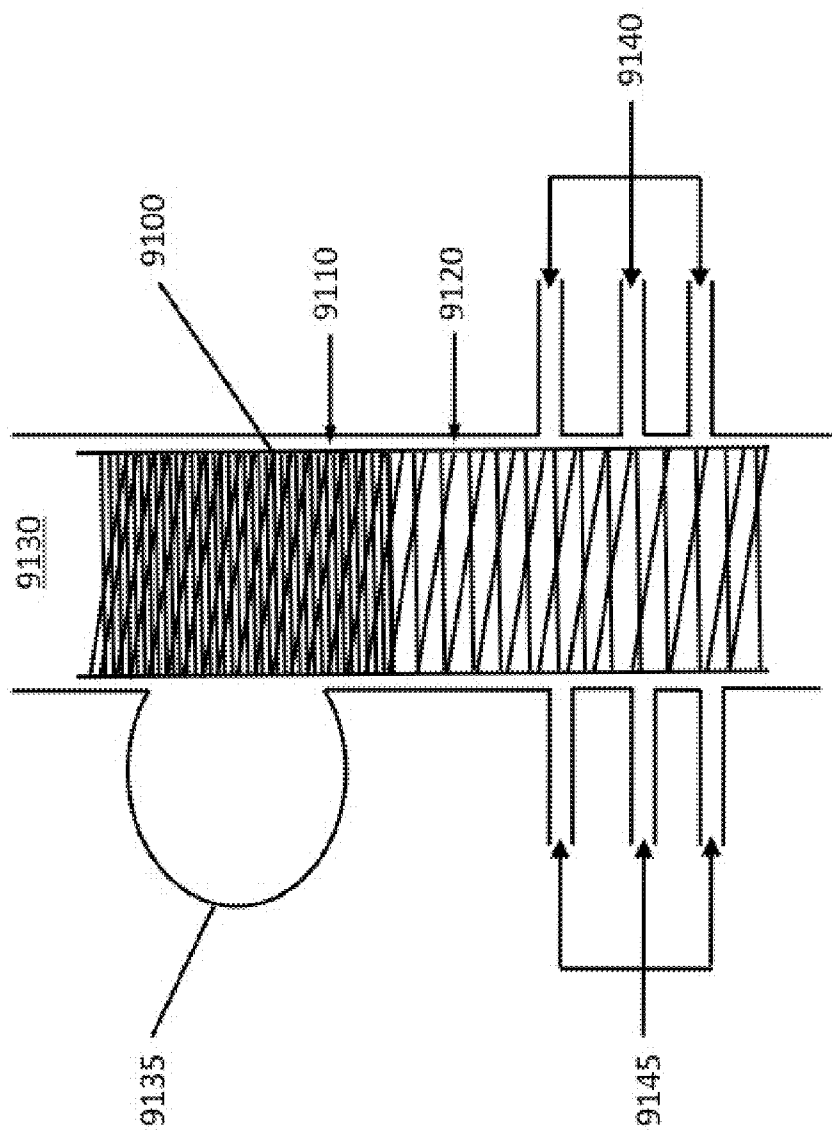


Fig. 28J

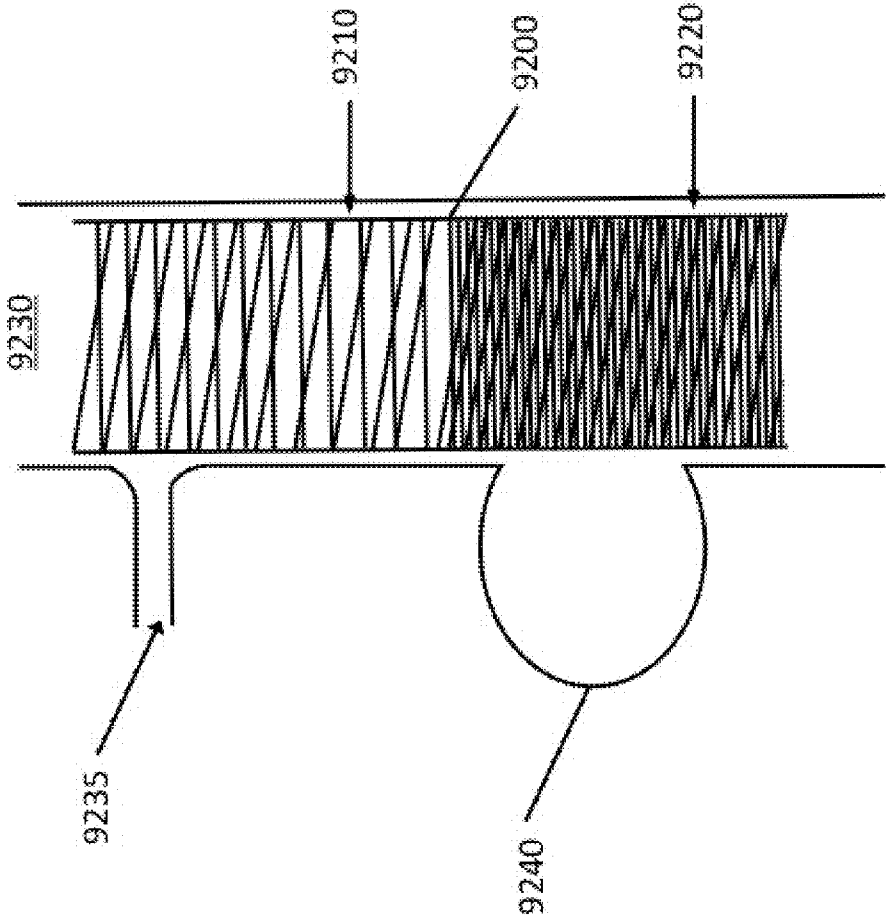


Fig. 28K

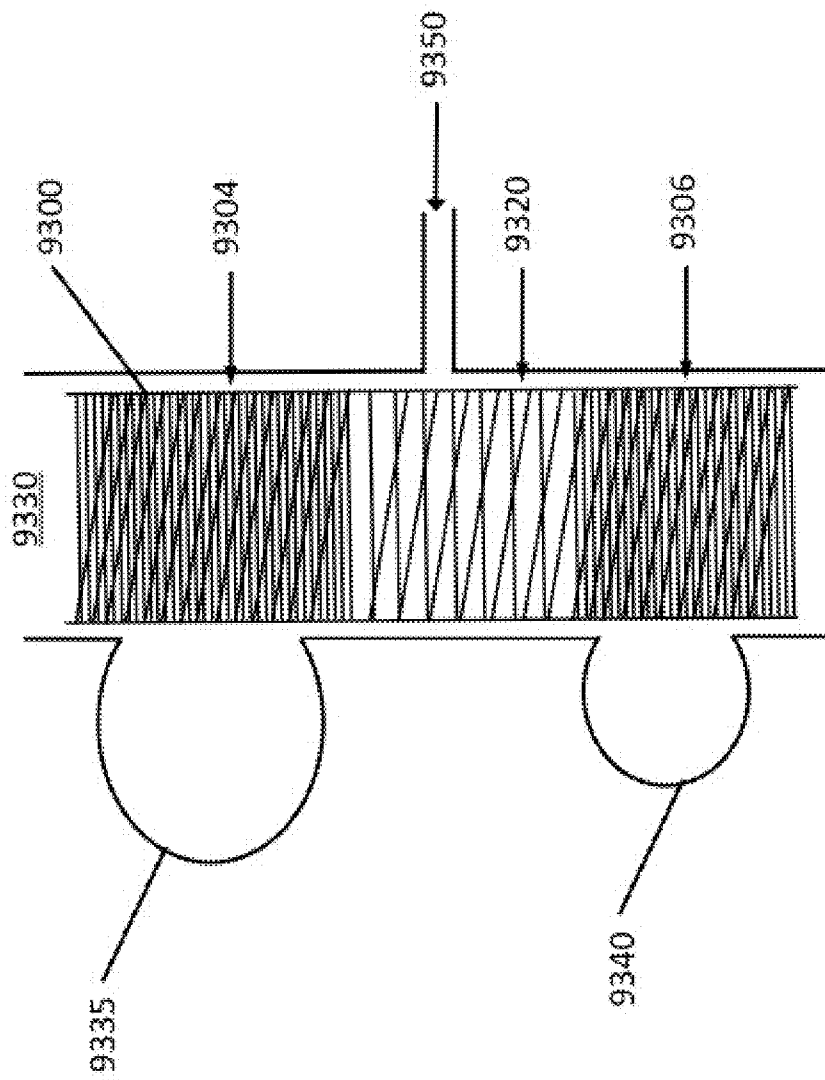


Fig. 28L

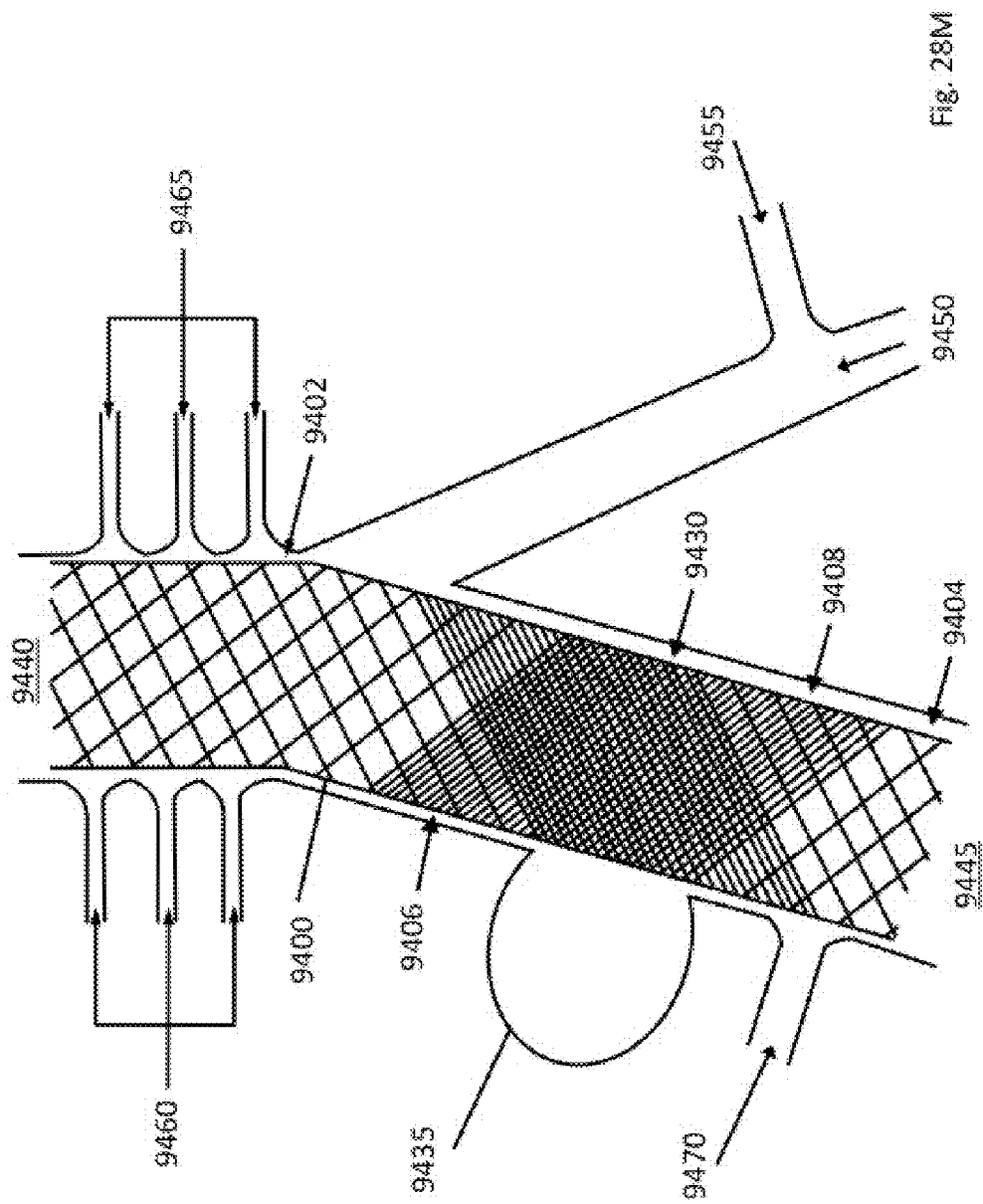


Fig. 28M

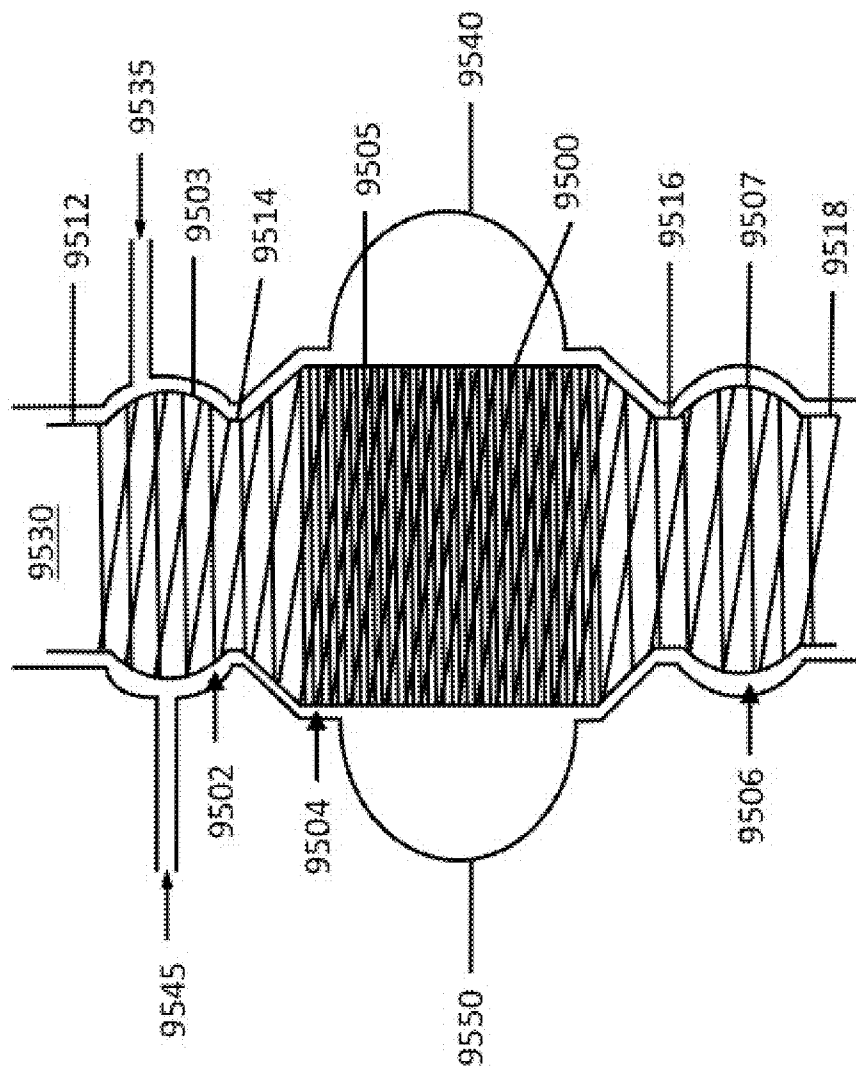


Fig. 28N



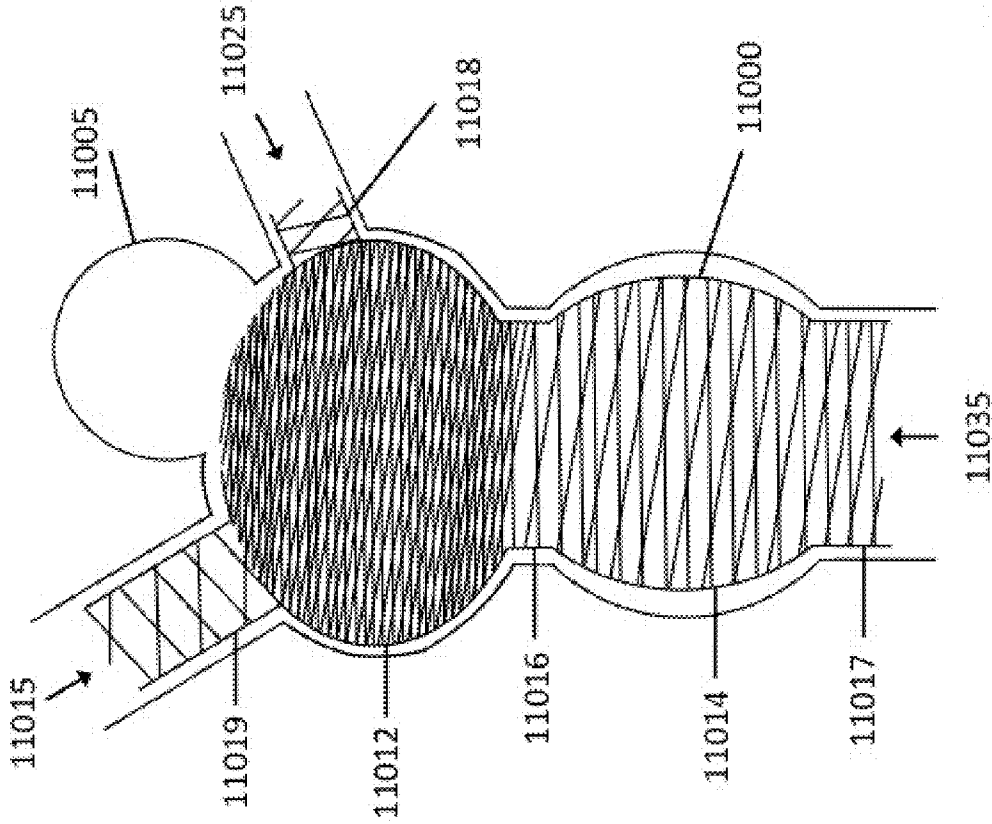


Fig. 280

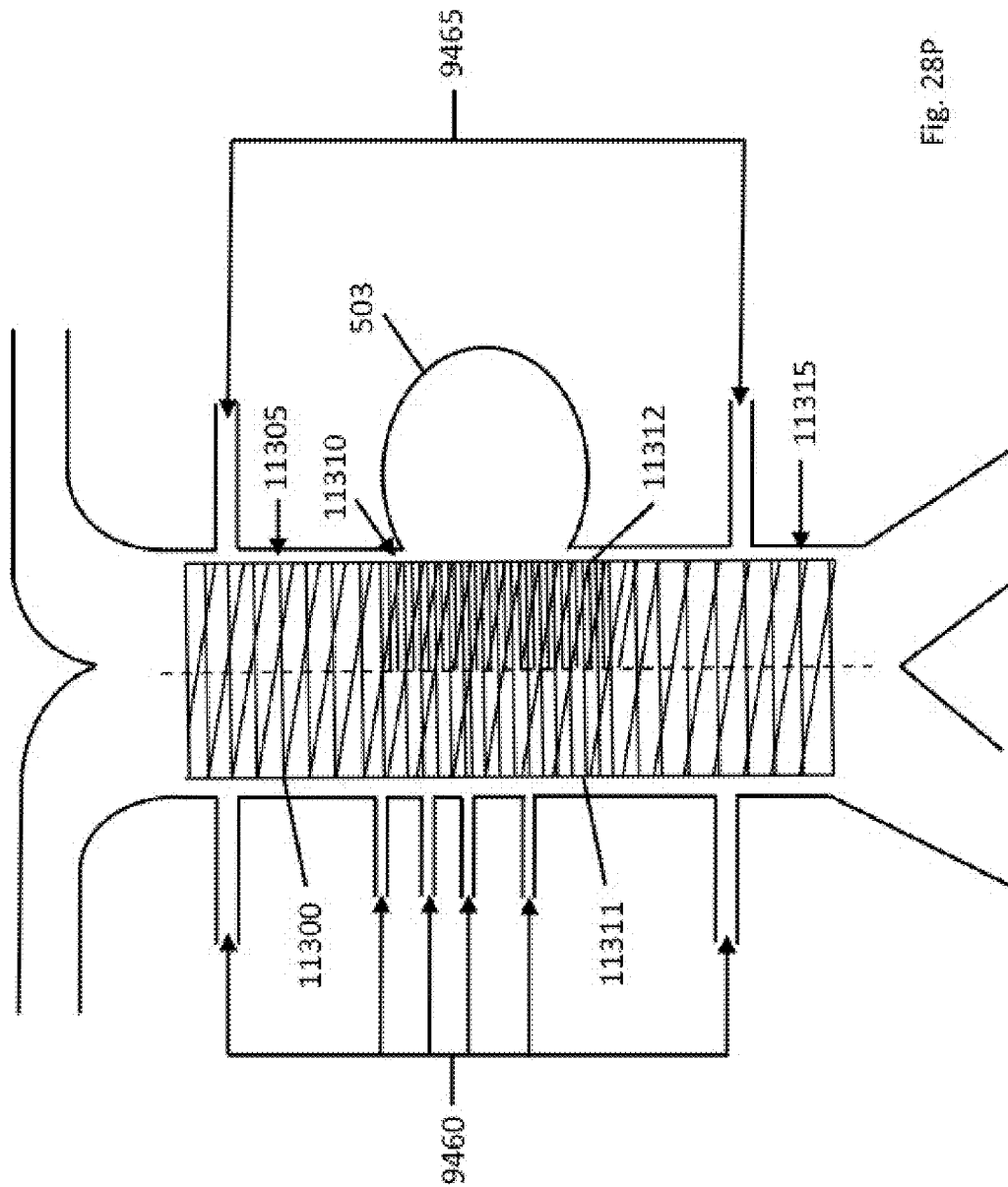


FIG. 28P



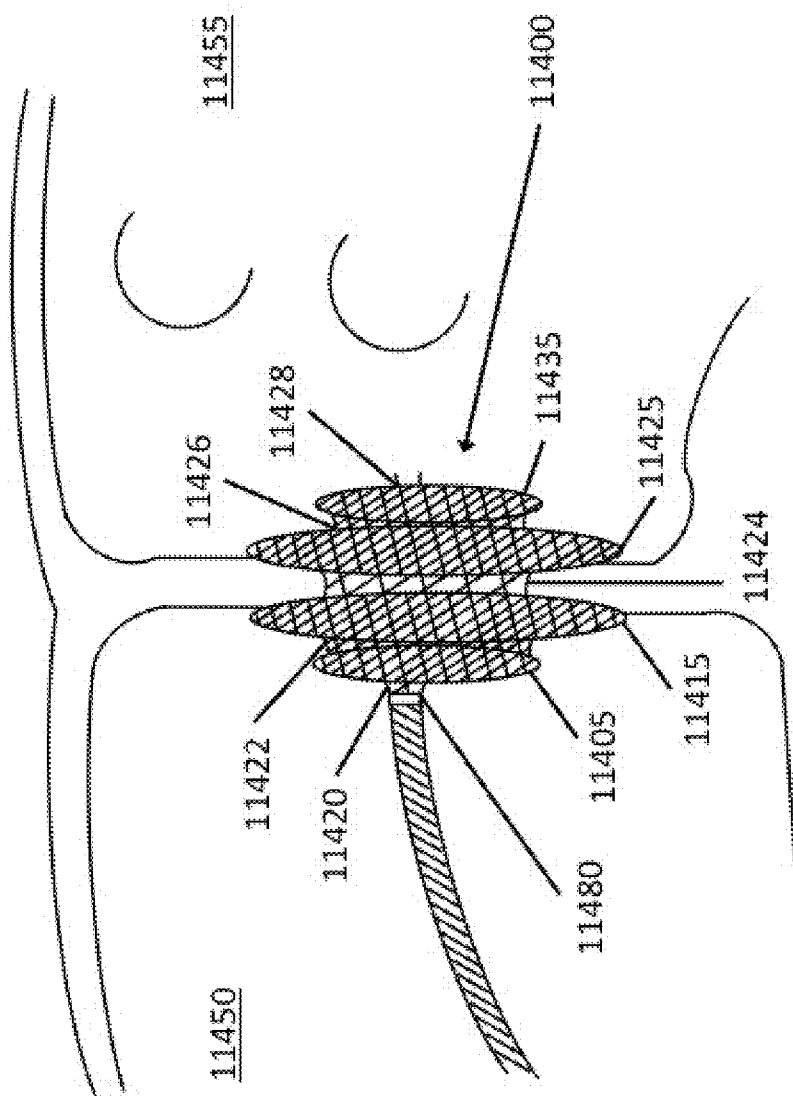


Fig. 29A

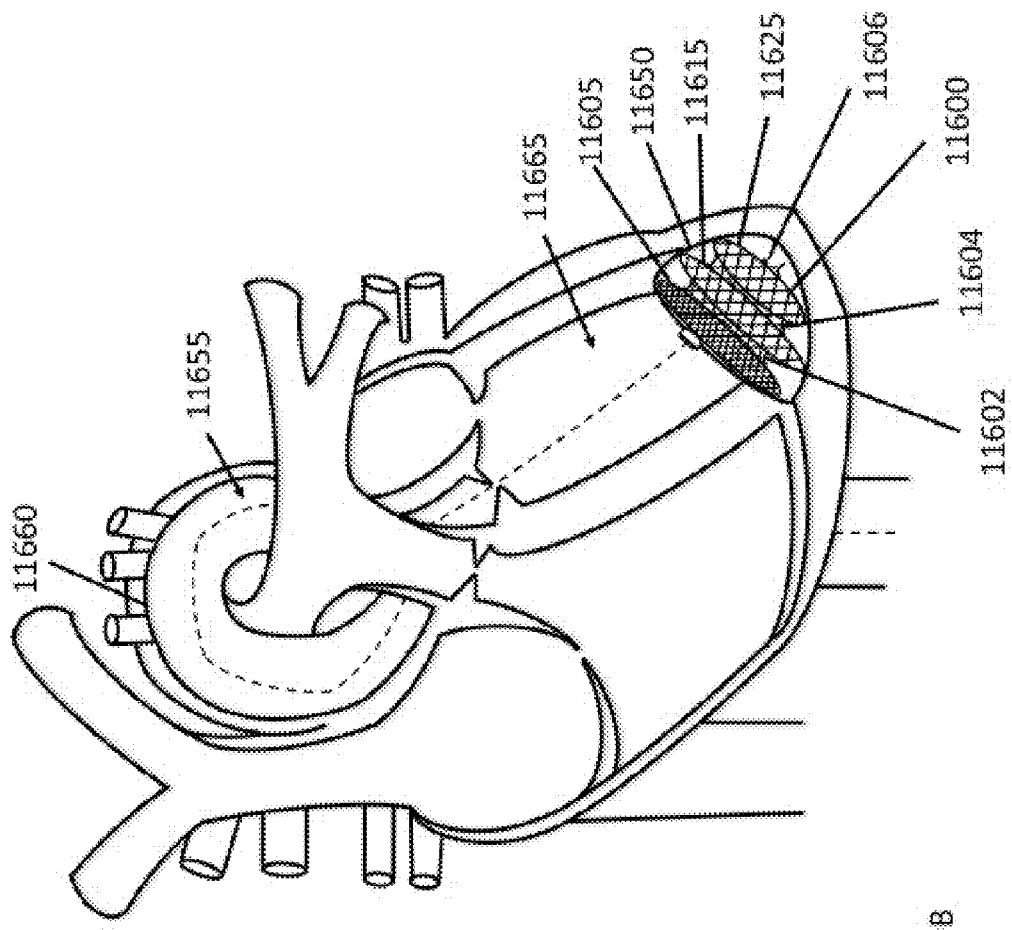


Fig. 29B

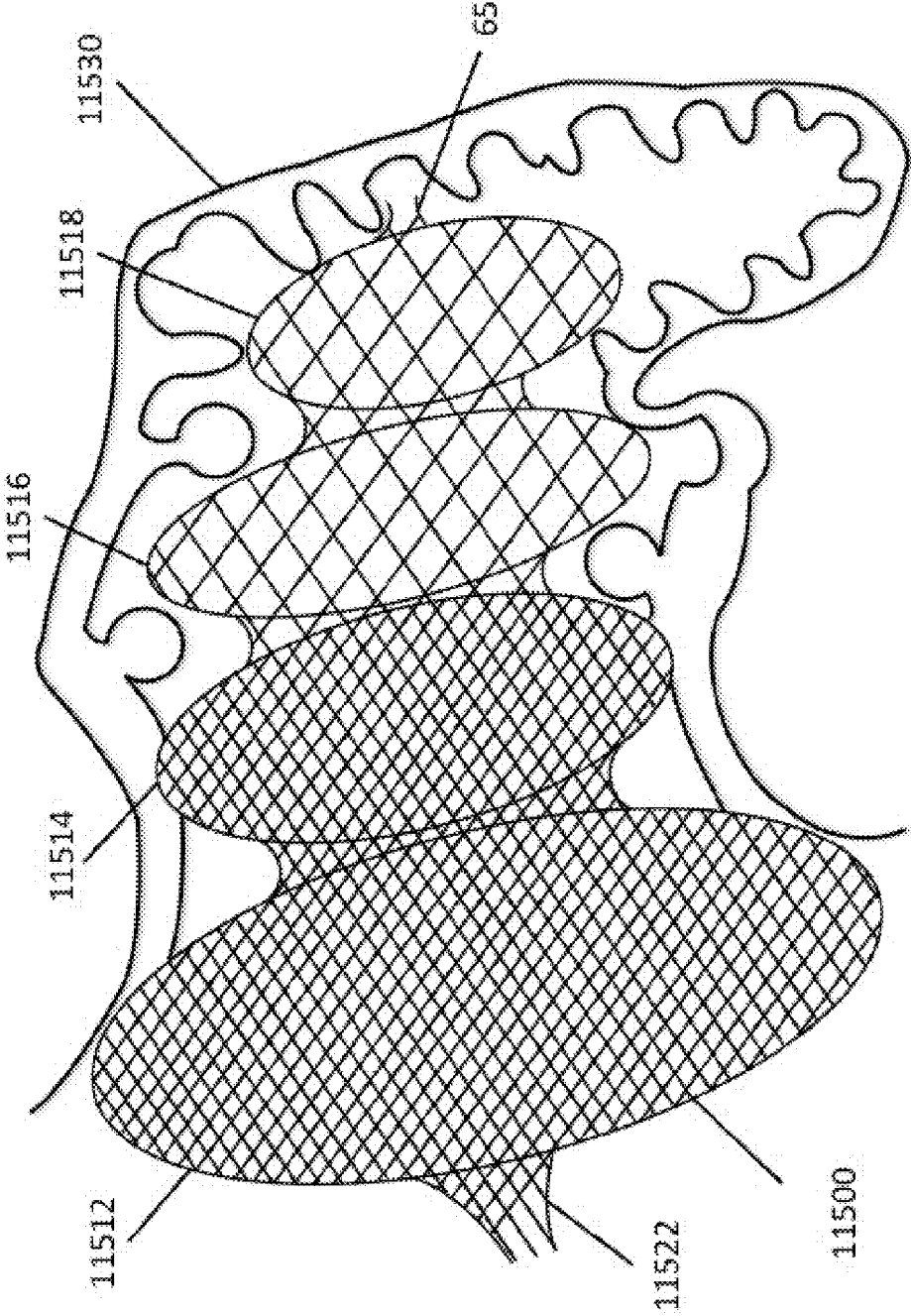


Fig. 29C

**VARIABLY HEAT-TREATED TUBULAR DEVICES**

**INCORPORATION BY REFERENCE TO ANY PRIORITY APPLICATIONS**

[0001] The present application is a continuation of U.S. patent application Ser. No. 13/953,540, filed on Jul. 29, 2013.

[0002] Any and all applications for which a foreign or domestic priority claim is identified in the Application Data Sheet as filed with the present application, as well as U.S. patent application Ser. No. 13/952,982, filed on Jul. 29, 2013, and U.S. Provisional Patent App. No. 61/798,540, filed on Mar. 15, 2013, are hereby incorporated by reference under 37 C.F.R. §1.57.

**BACKGROUND**

[0003] 1. Field

[0004] The present disclosure generally relates to devices, systems, methods for making, and methods for use in vascular procedures such as thrombectomy and/or flow diversion. Several embodiments relate to thrombectomy systems and methods for providing approaches for the treatment of stroke, peripheral vascular disease, coronary artery disease, saphenous vein graft disease, clogged hemodialysis grafts, cerebral venous sinus thrombosis, and deep venous thrombosis. Several embodiments relate to flow diversion and flow disruption systems and methods for providing approaches for the treatment of brain arterial aneurysms, aortic aneurysms, cardiac wall aneurysms, atrial septal defects and aneurysms including patent foramen ovale, ventricular septal defects and aneurysms, coronary arterial aneurysms, peripheral arterial aneurysms, renal arterial aneurysms, and vascular malformations including arterio-venous malformations and arterio-venous fistulae of the brain, spine, coronary and peripheral vasculature.

[0005] 2. Description of the Related Art

[0006] Stroke is the leading cause of long term disability in the United States and the second leading cause of death worldwide with over 4.4 million deaths in a year (1999). There are over 795,000 new strokes every year in the United States. Around 85% of all strokes are acute ischemic strokes caused from a blockage in a blood vessel or a blood clot occluding a blood vessel. In 1996, the FDA approved a thrombolytic drug to dissolve blood clots called recombinant tissue plasminogen activator (r-tpa). Despite practice guidelines from multiple national organizations stating that intravenous r-tpa is the standard of care for patients with acute ischemic stroke within 3 hours from symptom onset, only 3-4% of patients with acute ischemic stroke received this drug in the United States. Unlike intravenous r-tpa, catheter-based therapies for mechanical thrombectomy can be used for up to 8 hours or beyond from acute ischemic stroke symptom onset and could benefit more people. With advances in regional stroke networks, an increasing number of stroke patients are able to obtain access to intra-arterial thrombolysis and therapies.

**SUMMARY**

[0007] Certain embodiments described herein disclose devices and methods for removing a thrombus or thrombi. These thrombi include, but are not limited to, blood clots (e.g., attached to the blood vessel) and emboli (e.g., floating blood clots), as well as other debris. Several embodiments

provide devices comprising multiple bulbs. Vessels or other tissues in the body can become partially or fully clogged or blocked by a thrombus or thrombi. Although some clot retrievers or thrombectomy devices that employ a laser cut hypotube on a distal end of a wire are commercially available, some embodiments disclosed herein do not use laser cut struts and are gentle on the vessel wall, while effectively and efficiently capturing a thrombus in any location in the body. Some devices can be torsional rasped (e.g., wrung or twisted) to help capture thrombi. Certain embodiments described herein disclose devices and methods for treating aneurysms, vascular malformations, fistulas, and the like.

[0008] Several embodiments of the devices and methods described herein may be particularly beneficial by achieving one, some, or all of the following advantages:

[0009] adapted for, and gentle on, the fragile blood vessels in contrast to an expansile laser-cut stent-based mechanical thrombectomy device;

[0010] tapered to at least partially mimic the tapering of the human blood vessels, which can allow for the use of a single tapered device to remove blood clots extending across different tapering blood vessel diameters;

[0011] flexible during deployment and retrieval in tortuous human blood vessels, which can allow for longer usable lengths of the device;

[0012] comprises a usable length customizable to the length of a thrombus or clot burden without having to use multiple devices to remove the thrombus piecemeal;

[0013] a textile structure-based mechanical thrombectomy device that can allow for torsional rasping of the textile structure around a thrombus to entrap and retrieve the thrombus;

[0014] patterns of radiopaque filaments or wires that increase visibility under X-ray fluoroscopy;

[0015] allows for longitudinal crowding of filaments that varies pore sizes of certain sections during operation for selective filtering into bifurcated vessels;

[0016] patterns of radiopaque filaments or wires provide measurement estimates under X-ray fluoroscopy;

[0017] provides filtering of distal emboli or debris that may be released;

[0018] employs processes to couple a textile structure to a hypotube by bonding of different metals or alloys;

[0019] has a low overall profile in which the outer diameter of the mechanical thrombectomy device in the collapsed configuration is less than, e.g., about 0.0125 inches (approx. 0.317 mm);

[0020] has a low overall profile in which the mechanical thrombectomy device in the collapsed configuration can be deployed using a microcatheter that has an inner lumen diameter of less than, e.g., about 0.014 inch (approx. 0.355 mm);

[0021] varying slit patterns along the length of a hypotube, which can provide distal flexibility and proximal support;

[0022] varying shape set properties along the length of a hypotube, which can provide distal flexibility and proximal support;

[0023] a hypotube that can support the ability to perform torsional rasping of a thrombus;

[0024] a laser-cut hypotube with multiple transition points incorporated as the core braid for the wall of the microcatheter, which can allow for distal flexibility and proximal support for allowing the safe and effective deployment of the textile structure based mechanical thrombectomy device;

[0025] can be used without a separate embolic protection member (e.g., distal embolic protection member) to capture emboli;

[0026] can be used without reversal of blood flow, or otherwise impeding blood flow, to protect against release of distal emboli; and/or

[0027] can be used without a balloon or other inflation device.

[0028] In some embodiments, a method of treating a thrombus in a vessel with self-expanding bulbs comprises advancing a guidewire in the vessel proximal to the thrombus, advancing a guide catheter in the vessel and over the guidewire, after advancing the guide catheter, removing the guidewire from the vessel, and advancing a microwire in the vessel and through the guide catheter. Advancing the microwire includes crossing the thrombus (e.g., crossing the distal-most portion of the thrombus by 0.5 mm to 5 mm). The method further comprises advancing a microcatheter in the vessel and over the microwire. Advancing the microcatheter includes crossing the thrombus with a distal end of the microcatheter. The method further comprises, after advancing the microcatheter, removing the microwire from the vessel, and, after removing the microwire, inserting a thrombectomy device from an introducer sheath into the microcatheter. The thrombectomy device includes an elongate support structure and a delivery system coupled to the elongate support structure. The elongate support structure includes a plurality of wires woven to form a textile fabric. The elongate support structure may comprise or consist essentially of at least three (e.g., at least four, at least six, at least ten, etc.) self-expanding bulbs, a plurality of necks (e.g., longitudinally between and radially inward of the self-expanding bulbs), and a distal neck (e.g., radially inward of a distal-most bulb of the self-expanding bulbs). The delivery system includes a hypotube including a plurality of longitudinally-spaced kerfs including a plurality of interspersed cut patterns. A pitch of the plurality of longitudinally-spaced kerfs varies longitudinally along the hypotube. Each of the plurality of longitudinally-spaced kerfs includes rounded edges. The method further comprises, after inserting the thrombectomy device from the introducer sheath into the microcatheter, advancing the thrombectomy device in the vessel and through the microcatheter proximate to the distal end of the microcatheter. Advancing the thrombectomy device includes crossing the thrombus with the distal-most bulb of the self-expanding bulbs. The method further comprises, after advancing the thrombectomy device, maintaining a location of the delivery system of the thrombectomy device while retracting the microcatheter. Upon being unsheathed from the microcatheter, at least some of the self-expanding bulbs of the elongate support structure of the thrombectomy device self-expand from a radially compressed state to a radially expanded state. The microcatheter, in several embodiments, is retracted at least until the distal end of the microcatheter is proximal to the thrombus. The method further comprises retracting the microcatheter and the delivery system of the thrombectomy device into the guide catheter. During retraction of the microcatheter and the delivery system of the thrombectomy device, the some of the self-expanding bulbs remain in the radially expanded state, while others of the self-expanding bulbs of the elongate support structure of the thrombectomy device in the radially contracted state remain in the radially contracted state. In some embodiments, all the bulbs are partially or fully

expanded during retraction. In other embodiments, all the bulbs are partially or fully contracted during retraction.

[0029] The method may further comprise, before retracting the microcatheter and the delivery system of the thrombectomy device into the guide catheter, torsionally rasping the thrombectomy device to, for example, remove portions of the thrombus attached to an endothelium wall, entrap the thrombus in the radially expanded elongate support structure of the thrombectomy device, and/or collect emboli in the radially expanded elongate support structure. Retracting the microcatheter and the delivery system may be performed at a similar rate and while optionally applying negative pressure to the vessel. The vessel may comprise a blood vessel in a brain, leg, or other vessel or structure in the body.

[0030] In some embodiments, a method of treating a thrombus in a vessel with self-expanding bulbs comprises advancing a thrombectomy device through a microcatheter in the vessel and across the thrombus. The thrombectomy device includes an elongate support structure including more than two self-expanding bulbs and a delivery system coupled to the elongate support structure. The delivery system includes a hypotube including a plurality of longitudinally-spaced kerfs. The method further comprises retracting the microcatheter and expanding at least a portion of the elongate support structure of the thrombectomy device from a radially compressed state to a radially expanded state, torsionally rasping the thrombectomy device including entrapping the thrombus in the portion of the elongate support structure, and retracting the microcatheter and the delivery system of the thrombectomy device into a guide catheter in the vessel. Although the bulbs are self-expanding in several embodiments, bulbs that expand upon exertion of force (e.g., mechanical force) can be substituted in various embodiments described herein.

[0031] The elongate support structure may comprise at least two of the two or more bulbs having different outer diameters in the radially expanded state. The elongate support structure may be tapered. The plurality of longitudinally spaced kerfs of the hypotube may include a plurality of interspersed cut patterns. A pitch of the plurality of longitudinally spaced kerfs of the hypotube may vary longitudinally along the hypotube. The thrombectomy device in the radially compressed state may have a thickness less than 0.0125 inches. Torsionally rasping the thrombectomy device may include removing portions of the thrombus attached to an endothelium wall. Torsionally rasping the thrombectomy device may include collecting one or more emboli released from the thrombus in the portion of the elongate support structure. Expanding the portion of the elongate support structure from the radially compressed state to the radially expanded state may comprise expanding the vessel by 0% to 30%. During torsionally rasping the thrombectomy device, a ratio of rotation of the delivery system of the thrombectomy device to rotation of the elongate support structure of the thrombectomy device may be between 1:0.5 and 1:0.25. Torsionally rasping the thrombectomy device may comprise rotating the delivery system of the thrombectomy device at least 360 degrees, resulting in a rotation of the elongate support structure of the thrombectomy device of less than 360 degrees. The vessel may comprise a blood vessel in a brain, leg, or other vessel or structure in the body.

[0032] In some embodiments, a method of treating a thrombus in a vessel with self-expanding bulbs comprises advancing a thrombectomy device through a microcatheter in the vessel. The thrombectomy device includes a plurality of self-



expanding bulbs and a hypotube coupled to the self-expanding bulbs. The method further comprises retracting the microcatheter to expand from a radially compressed state to a radially expanded state at least some of the plurality of self-expanding bulbs, entrapping the thrombus in at least some of the plurality of self-expanding bulbs in the radially expanded state, and retracting the microcatheter and the thrombectomy device.

**[0033]** The hypotube may include a plurality of longitudinally-spaced kerfs. The method may further comprise torsionally rasping the thrombectomy device. Torsionally rasping the thrombectomy device may include entrapping the thrombus in the at least some of the plurality of self-expanding bulbs in the radially expanded state. The vessel may comprise a blood vessel in a brain, leg, or other vessel or structure in the body.

**[0034]** In some embodiments, a thrombectomy device comprises, or consists essentially of, an elongate support structure, a delivery system, and a bonding zone where the delivery system is coupled to the elongate support structure. The elongate support structure includes a plurality of shape-memory and radiopaque wires woven to form a textile fabric having a collapsed state and an expanded state. The elongate support structure includes, or consists essentially of, a plurality of self-expanding generally spherical bulbs in the expanded state, necks longitudinally between and radially inward of the self-expanding bulbs, and a distal neck distal to and radially inward of a distal-most bulb of the self-expanding bulbs. In one embodiment, the plurality of bulbs consists essentially of five to fifteen bulbs that have rounded or curved portions. In several embodiments, the plurality of self-expanding generally spherical bulbs includes a first bulb, a second bulb distal to the first bulb, a third bulb distal to the second bulb, a fourth bulb distal to the third bulb, a fifth bulb distal to the fourth bulb, a sixth bulb distal to the fifth bulb, a seventh bulb distal to the sixth bulb, an eighth bulb distal to the seventh bulb, a ninth bulb distal to the eighth bulb, and a tenth bulb distal to the ninth bulb. The first bulb and the second bulb have a first diameter. The third bulb and the fourth bulb have a second diameter smaller than the first diameter. The fifth bulb, the sixth bulb, and the seventh bulb have a third diameter smaller than the second diameter. The eighth bulb, the ninth bulb, and the tenth bulb have a fourth diameter smaller than the third diameter. The distal neck includes a coated distal end in several embodiments. The delivery system may include a hypotube including two longitudinally interspersed and circumferentially staggered cut patterns. The cut patterns may each include a plurality of rows each including two longitudinally-spaced kerfs angled with respect to a longitudinal axis of the hypotube and including rounded edges. A longitudinally-spacing of the kerfs may vary along the hypotube. The bonding zone includes a radiopaque marker band in some embodiments.

**[0035]** An outer diameter of the elongate support structure in the collapsed state may be less than about 0.0125 inches. An outer diameter of the elongate support structure in the collapsed state may be in a range of about 0.1-0.9 mm (e.g., about 0.25 mm to about 0.5 mm). The first diameter may be about 4.5 mm. The second diameter may be about 4 mm. The third diameter may be about 3.5 mm. The fourth diameter may be about 3 mm.

**[0036]** In some embodiments, a thrombectomy device comprises an elongate support structure and a delivery system. The elongate support structure includes a plurality of

wires woven to form a textile fabric having a collapsed state and an expanded state. The elongate support structure includes a plurality of longitudinally-spaced self-expanding bulbs in the expanded state. The delivery system includes a hypotube including a plurality of longitudinally interspersed cut patterns each including a plurality of rows of longitudinally-spaced kerfs.

**[0037]** The plurality of bulbs may comprise or consist essentially of ten or more bulbs. At least two of the plurality of bulbs may have different outer diameters in the expanded state. At least two of the plurality of bulbs may have different shapes in the expanded state. At least one of the plurality of bulbs may have a spherical shape in the expanded state. At least one of the plurality of bulbs may have an oblong shape in the expanded state. Longitudinal spacing between the plurality of bulbs may be constant. The plurality of wires may include shape memory and radiopaque wires. The radiopaque wires may be clustered to enhance visibility under x-ray. An outer diameter of the elongate support structure in the collapsed state may be less than about 0.0125 inches. Each of the rows may be angled with respect to a longitudinal axis of the hypotube. The kerfs may include rounded edges. Although ten or more bulbs (e.g., 15, 20, 25, 30, or more bulbs) are provided in some embodiments, fewer than ten bulbs are provided in other embodiments (for example, for shorter targeted segments).

**[0038]** In some embodiments, a device for treating a thrombus in a vessel comprises or consists essentially of an elongate support structure including a plurality of wires woven to form a textile structure including a plurality of bulbs in a radially expanded state, a delivery system including a hypotube including at least two interspersed patterns of longitudinally-spaced rows of kerfs, and a bonding zone where the delivery system may be coupled to the elongate support structure. The bonding zone includes a radiopaque marker band in some embodiments.

**[0039]** The bonding zone may include a proximal end of the elongate support structure within a distal end of the delivery system. The bonding zone may include a proximal end of the elongate support structure over a distal end of the delivery system. The bonding zone may include a distal end of the elongate support structure over a distal end of the delivery system.

**[0040]** In some embodiments, a method of treating a thrombus in a vessel with self-expanding bulbs comprises advancing a microwire in the vessel and through a guide catheter. Advancing the microwire includes crossing the thrombus with a distal end of the microwire. The method further comprises advancing a microcatheter in the vessel and over the microwire. Advancing the microcatheter includes crossing the thrombus with a distal end of the microcatheter. The method further comprises, after advancing the microcatheter, removing the microwire from the vessel, and, after removing the microwire, inserting a thrombectomy device in a radially compressed state into the microcatheter. The thrombectomy device includes a distal portion and a proximal portion bonded to the distal portion. The distal portion includes a plurality of wires woven to form a textile fabric. The distal portion comprises at least three (e.g., at least four, at least six, at least ten, etc.) self-expanding bulbs and necks between and radially inward of the self-expanding bulbs. The proximal portion includes a hypotube including a plurality of longitudinally-spaced kerfs including a plurality of interspersed cut patterns. A pitch of the plurality of longitudinally-spaced

kerfs varies longitudinally along the hypotube. The method further comprises, after inserting the thrombectomy device into the microcatheter, advancing the thrombectomy device in the vessel and through the microcatheter proximate to the distal end of the microcatheter. Advancing the thrombectomy device includes crossing the thrombus with the distal-most bulb of the self-expanding bulbs. The method further comprises, after advancing the thrombectomy device, maintaining a location of the proximal portion of the thrombectomy device while proximally retracting the microcatheter. Upon being unsheathed from the microcatheter, at least some of the self-expanding bulbs of the elongate support structure of the thrombectomy device self-expand from a radially compressed state to a radially expanded state. Retracting the microcatheter is at least until the distal end of the microcatheter is proximal to the thrombus. The method further comprises, after retracting the microcatheter, torsionally rasping the thrombectomy device including removing portions of the thrombus attached to an endothelium wall, entrapping the thrombus in the radially expanded distal portion of the thrombectomy device, and collecting emboli in the radially expanded distal portion of the thrombectomy device. The method further comprises, after torsionally rasping the thrombectomy device, retracting at a similar rate the microcatheter and the proximal portion of the thrombectomy device. The vessel may comprise a blood vessel in a brain, leg, or other vessel or structure in the body.

**[0041]** In some embodiments, a method of treating a thrombus in a vessel with self-expanding bulbs comprises expanding from a radially compressed state to a radially expanded state a plurality of self-expanding bulbs of a distal portion of a thrombectomy device, entrapping the thrombus in at least some of the plurality of self-expanding bulbs in the radially expanded state, and retracting the thrombectomy device from the vessel.

**[0042]** The distal portion of the thrombectomy device comprises at least two of the plurality of bulbs may have different outer diameters in the radially expanded state. The distal portion of the thrombectomy device may be tapered. The distal portion of the thrombectomy device may comprise at least two of the plurality of self-expanding bulbs having different shapes in the radially expanded state. The distal portion of the thrombectomy device may comprise at least two of the plurality of self-expanding bulbs separated by a neck. The thrombectomy device may comprise a proximal portion coupled to the distal portion. The proximal portion may include a hypotube including a plurality of longitudinally spaced kerfs. The plurality of longitudinally spaced kerfs may include a plurality of interspersed cut patterns. A pitch of the plurality of longitudinally spaced kerfs may vary longitudinally along the hypotube. At least some of the plurality of longitudinally spaced kerfs may include rounded edges. Expanding the plurality of self-expanding bulbs may include proximally retracting a microcatheter surrounding the plurality of self-expanding bulbs in the radially compressed state. Retracting the microcatheter may be at least until a distal end of the microcatheter is proximal to the thrombus. Retracting the thrombectomy device from the vessel comprises retracting the microcatheter may be at a similar rate. Entrapping the thrombus may include torsionally rasping the thrombectomy device. The vessel may comprise a blood vessel in a brain, leg, or other vessel or structure in the body.

**[0043]** In some embodiments, a method of treating a thrombus in a vessel with self-expanding bulbs comprises torsion-

ally rasping a distal portion of a thrombectomy device. The distal portion includes a plurality of self-expanding bulbs. Torsionally rasping may effect at least one of: removing portions of the thrombus attached to an endothelium wall of the vessel, entrapping the thrombus in the distal portion of the thrombectomy device, and collecting emboli in the distal portion of the thrombectomy device.

**[0044]** Torsionally rasping the distal portion of the thrombectomy device may comprise rotating a proximal portion of the thrombectomy device coupled to the distal portion of the thrombectomy device. The proximal portion may include a hypotube including a plurality of longitudinally-spaced kerfs. The vessel may comprise a blood vessel in a brain, leg, or other vessel or structure in the body.

**[0045]** In some embodiments, a device for treating a thrombus in a vessel comprises a distal portion and a proximal portion coupled to a proximal end of the distal portion. The distal portion includes a plurality of wires woven to form a textile structure. The plurality of wires includes radiopaque wires and shape-memory wires. The distal portion includes at least ten self-expanding bulbs, at least nine necks longitudinally between the ten self-expanding bulbs and radially inward of the ten self-expanding bulbs, and a distal neck distal to the distal-most of the at least ten self-expanding bulbs. The proximal portion includes a hypotube having a longitudinal axis. The proximal portion comprises a first pattern of longitudinally-spaced rows each including two kerfs and two stems and a second pattern of longitudinally-spaced rows each including two kerfs and two stems. The rows of the first pattern are at an angle with respect to the longitudinal axis of the hypotube. The two kerfs in each of the rows of the first pattern have rounded edges. The two stems in each of the rows of the first pattern are circumferentially 180° apart. The stems of the first pattern are offset in a first circumferential direction. A pitch of the longitudinally-spaced rows of the first pattern varies longitudinally along the hypotube. The rows of the second pattern is at an angle with respect to the longitudinal axis of the hypotube. The two kerfs in each of the rows of the second pattern have rounded edges. The two stems in each of the rows of the second pattern are circumferentially 180° apart. The rows of the second pattern are singly alternately interspersed with the rows of the first pattern. The stems of the second pattern offset in a second circumferential direction opposite the first circumferential direction. A pitch of the longitudinally-spaced kerfs of the second pattern varies longitudinally along the hypotube.

**[0046]** The at least ten self-expanding bulbs may comprise a first bulb, a second bulb distal to the first bulb, a third bulb distal to the second bulb, a fourth bulb distal to the third bulb, a fifth bulb distal to the fourth bulb, a sixth bulb distal to the fifth bulb, a seventh bulb distal to the sixth bulb, an eighth bulb distal to the seventh bulb, a ninth bulb distal to the eighth bulb, and a tenth bulb distal to the ninth bulb. The first bulb and the second bulb may have a first diameter. The third bulb and the fourth bulb may have a second diameter smaller than the first diameter. The fifth bulb, the sixth bulb, and the seventh bulb may have a third diameter smaller than the second diameter. The eighth bulb, the ninth bulb, and the tenth bulb may have a fourth diameter smaller than the third diameter. The second bulb may have a generally spherical shape. The third bulb may have a generally oblong shape. The fourth bulb may have a generally spherical shape. The fifth bulb may have a generally oblong shape. The sixth bulb may have a generally spherical shape. The seventh bulb may have a gen-

erally spherical shape. The eighth bulb may have a generally oblong shape. The ninth bulb may have a generally spherical shape. The tenth bulb may have a generally spherical shape.

**[0047]** In some embodiments, a device for treating a thrombus in a vessel comprises a first portion and a second portion bonded to the first portion. The first portion includes a plurality of wires woven to form a textile structure. The plurality of wires includes radiopaque wires and shape-memory wires, the textile structure includes a plurality of bulbs spaced by a plurality of necks in a radially expanded state. The second portion includes a hypotube having a longitudinal axis. The hypotube includes at least two interspersed patterns of longitudinally-spaced rows of kerfs. A pitch of the longitudinally-spaced rows of kerfs varies along the longitudinal axis of the hypotube.

**[0048]** The plurality of bulbs may include ten or more bulbs. Fewer bulbs are included in some embodiments. At least two of the plurality of bulbs may have different outer diameters in the radially expanded state. At least two of the plurality of bulbs may have different shapes in the radially expanded state. At least one of the plurality of bulbs may have a spherical shape in the radially expanded state. At least one of the plurality of bulbs may have an oblong shape in the radially expanded state. The radiopaque wires are spaced or clustered to increase visibility under x-ray. Each of the rows may be angled with respect to the longitudinal axis of the hypotube. Each of the rows may include two kerfs and two stems. The stems in each of the rows may be circumferentially 180° apart. The at least two interspersed patterns may include a first pattern including the stems circumferentially offset in a first direction and a second pattern including the stems circumferentially offset in a second direction opposite the first direction.

**[0049]** In some embodiments, a device for treating a thrombus in a vessel comprises a first portion including a plurality of wires woven to form a textile structure including a plurality of bulbs in a radially expanded state, a second portion including a hypotube including at least two interspersed patterns of longitudinally-spaced rows of kerfs, and a joint coupling the first portion and the second portion.

**[0050]** The joint may include lead-free solder. The joint may include a proximal end of the first portion within a distal end of the second portion. The joint may include a proximal end of the first portion over a distal end of the second portion. The joint may include a distal end of the first portion over a distal end of the second portion.

**[0051]** In some embodiments, a device for treating a thrombus in a vessel comprises a plurality of wires woven to form a textile fabric. The textile fabric includes ten self-expanding bulbs, nine necks longitudinally between the ten self-expanding bulbs, and a distal neck distal to the distal-most of the ten self-expanding bulbs. The plurality of wires includes a plurality of radiopaque wires and a plurality of shape-memory wires.

**[0052]** The ten self-expanding bulbs may comprise a first bulb, a second bulb distal to the first bulb, a third bulb distal to the second bulb, a fourth bulb distal to the third bulb, a fifth bulb distal to the fourth bulb, a sixth bulb distal to the fifth bulb, a seventh bulb distal to the sixth bulb, an eighth bulb distal to the seventh bulb, a ninth bulb distal to the eighth bulb, and a tenth bulb distal to the ninth bulb. The first bulb and the second bulb may have a first diameter. The third bulb and the fourth bulb may have a second diameter smaller than the first diameter. The fifth bulb, the sixth bulb, and the seventh bulb

may have a third diameter smaller than the second diameter. The eighth bulb, the ninth bulb, and the tenth bulb may have a fourth diameter smaller than the third diameter. The first bulb may have a generally oblong shape. The second bulb may have a generally spherical shape. The third bulb may have a generally oblong shape. The fourth bulb may have a generally spherical shape. The fifth bulb may have a generally oblong shape. The sixth bulb may have a generally spherical shape. The seventh bulb may have a generally spherical shape. The eighth bulb may have a generally oblong shape. The ninth bulb may have a generally spherical shape. The tenth bulb may have a generally spherical shape. The first bulb and the second bulb may have a first diameter. The third bulb and the fourth bulb may have a second diameter smaller than the first diameter. The fifth bulb, the sixth bulb, and the seventh bulb may have a third diameter smaller than the second diameter. The eighth bulb, the ninth bulb, and the tenth bulb may have a fourth diameter smaller than the third diameter.

**[0053]** In some embodiments, a device for treating a thrombus in a vessel comprises a plurality of wires woven to form a textile fabric including a plurality of bulbs spaced by a plurality of necks in a radially expanded state. The plurality of wires includes shape-memory wires and clustered radiopaque wires.

**[0054]** The radiopaque wires may include platinum tungsten. The shape memory wires may include nickel titanium. The plurality of bulbs may include ten bulbs. At least two of the plurality of bulbs may have different outer diameters in the radially expanded state. A diameter of the device in a collapsed state may be no more than about 0.0125 inches (approx. 0.317 mm). At least two of the plurality of bulbs may have different shapes in the radially expanded state. At least one of the plurality of bulbs may have a spherical shape in the radially expanded state. At least one of the plurality of bulbs may have an oblong shape in the radially expanded state.

**[0055]** In some embodiments, a device for treating a thrombus in a vessel comprises a plurality of wires woven to form a textile fabric including a radially collapsed state having a diameter between about 0.1 mm and about 0.9 mm (e.g., between about 0.25 mm and about 0.5 mm) and a radially expanded state having a diameter between about 1 mm and about 30 mm (e.g., between about 1 mm and about 6.5 mm, between about 3 mm and about 4.5 mm). In some embodiments, the radially contracted state is about 10 to about 30 times smaller in at least one dimension than the radially expanded state. The textile fabric includes a plurality of bulbs in the radially expanded state.

**[0056]** The plurality of bulbs may include ten bulbs. At least two of the plurality of bulbs may have different outer diameters in the radially expanded state. At least two of the plurality of bulbs may have different shapes in the radially expanded state. At least one of the plurality of bulbs may have a spherical shape in the radially expanded state. At least one of the plurality of bulbs may have an oblong shape in the radially expanded state. The plurality of bulbs may be spaced by necks.

**[0057]** In some embodiments, a device for treating a thrombus in a vessel comprises a hypotube having a longitudinal axis. The hypotube includes a first pattern of longitudinally-spaced rows each including two kerfs and two stems and a second pattern of longitudinally-spaced rows each including two kerfs and two stems. The rows of the first pattern are at an angle with respect to the longitudinal axis of the hypotube.

The two kerfs in each of the rows of the first pattern have rounded edges. The two stems in each of the rows of the first pattern are circumferentially about 180° apart. The stems of the first pattern are offset in a first circumferential direction. The rows of the second pattern are at an angle with respect to the longitudinal axis of the hypotube. The two kerfs in each of the rows of the second pattern have rounded edges. The two stems in each of the rows of the second pattern are circumferentially about 180° apart. The rows of the second pattern are singly alternatingly interspersed with the rows of the first pattern. The stems of the second pattern are offset in a second circumferential direction opposite the first circumferential direction. A pitch of the longitudinally-spaced kerfs of first pattern and the second pattern varies longitudinally along the hypotube.

**[0058]** The hypotube may include a first section, a second section, a third section, a fourth section, a fifth section, and a sixth section. The first section may have a pitch of about 0.005 inches (approx. 0.13 mm). The second section may have a pitch of about 0.01 inches (approx. 0.25 mm). The third section may have a pitch of about 0.02 inches (approx. 0.51 mm). The fourth section may have a pitch of about 0.04 inches (approx. 1 mm). The fifth section may have a pitch of about 0.08 inches (approx. 2 mm). The sixth section may have a pitch of about 0.016 inches (approx. 4 mm). The first section may be a distal-most section of the hypotube. The first section may be 20% of the hypotube. The second section may be proximal to the first section. The second section may be 15% of the hypotube. The third section may be proximal to the second section. The third section may be 15% of the hypotube. The fourth section may be proximal to the third section. The fourth section may be 15% of the hypotube. The fifth section may be proximal to the fourth section. The fifth section may be 15% of the hypotube. The sixth section may be proximal to the fifth section. The sixth section may be 20% of the hypotube. The first pattern and the second pattern may be laser-cut.

**[0059]** In some embodiments, a device for treating a thrombus in a vessel comprises a hypotube having a longitudinal axis. The hypotube includes a first pattern of longitudinally-spaced rows each including two kerfs and two stems and a second pattern of longitudinally-spaced rows each including two kerfs and two stems. The two stems in each of the rows of the first pattern are circumferentially about 180° apart. The stems of the first pattern are offset in a first circumferential direction. The two stems in each of the rows of the second pattern are circumferentially about 180° apart. The rows of the second pattern are interspersed with the rows of the first pattern. The stems of the second pattern are offset in a second circumferential direction opposite the first circumferential direction.

**[0060]** The first pattern may be singly alternatingly dispersed with the second pattern. Each of the rows may be angled with respect to the longitudinal axis of the hypotube. The kerfs in each of the rows of the first pattern and the second pattern may have rounded edges. A pitch of the longitudinally-spaced rows of the first pattern and the second pattern may vary longitudinally along the hypotube. The hypotube may include a first section, a second section, a third section, a fourth section, a fifth section, and a sixth section. The first section may have a pitch of about 0.005 inches (approx. 0.13 mm). The second section may have a pitch of about 0.01 inches (approx. 0.25 mm). The third section may have a pitch of about 0.02 inches (approx. 0.51 mm). The fourth section

may have a pitch of about 0.04 inches (approx. 1 mm). The fifth section may have a pitch of about 0.08 inches (approx. 2 mm). The sixth section may have a pitch of about 0.016 inches (approx. 4 mm). The first section may be a distal-most section of the hypotube. The first section may be 20% of the hypotube. The second section may be proximal to the first section. The second section may be 15% of the hypotube. The third section may be proximal to the second section. The third section may be 15% of the hypotube. The fourth section may be proximal to the third section. The fourth section may be 15% of the hypotube. The fifth section may be proximal to the fourth section. The fifth section may be 15% of the hypotube. The sixth section may be proximal to the fifth section. The sixth section may be 20% of the hypotube. The first pattern and the second pattern may be laser-cut.

**[0061]** In some embodiments, a device for treating a thrombus in a vessel comprises a hypotube including a first pattern of longitudinally-spaced rows each including two kerfs and two stems and a second pattern of longitudinally-spaced rows each including two kerfs and two stems. The stems of the first pattern are offset in a first circumferential direction. The rows of the second pattern are interspersed with the rows of the first pattern. The stems of the second pattern are offset in a second circumferential direction opposite the first circumferential direction.

**[0062]** The two stems in each of the rows of the first pattern may be circumferentially about 180° apart. The two stems in each of the rows of the second pattern may be circumferentially about 180° apart. The hypotube may have a longitudinal axis. A pitch of the longitudinally-spaced rows of kerfs may vary along the longitudinal axis of the hypotube. The first pattern may be singly alternatingly dispersed with the second pattern. Each of the rows may be angled with respect to the longitudinal axis of the hypotube. The kerfs in each of the rows of the first pattern and the second pattern may have rounded edges. The first pattern and the second pattern may be laser-cut. The hypotube may comprise stainless steel or nitinol.

**[0063]** In some embodiments, a method of manufacturing a thrombus treatment device comprises arranging a plurality of spools on a yarn wheel, braiding the radiopaque wires and the shape memory wires in a one-over-one-under-one pattern around a first mandrel to form a textile structure, shape setting the textile structure in a substantially cylindrical shape, securing the shape-set textile structure on a second mandrel including bulbs and necks, shape setting the shape-set textile structure on the second mandrel, and removing the shape-set textile structure from the second mandrel. At least some of the spools including radiopaque wires and at least some of the spools include shape memory wires.

**[0064]** Securing the shape-set textile structure on the second mandrel may include wrapping wire around the necks of the second mandrel. The radiopaque wires may include platinum tungsten wires. The shape memory wires may include nickel titanium wires. The method may further comprise bonding the shape-set textile structure to a delivery system. Bonding the shape-set textile structure to the delivery system may comprise inlay bonding. The method may further comprise, before bonding the shape-set textile structure to the delivery system, positioning the wires in a pinch ring or a pinch cylinder. Bonding the shape-set textile structure to the delivery system may comprise overlay bonding. Bonding the shape-set textile structure to the delivery system may comprise bonding a proximal end of the shape-set textile structure

to a distal end of the delivery system. Bonding the shape-set textile structure to the delivery system may comprise bonding a distal end of the shape-set textile structure to a distal end of the delivery system. Bonding the shape-set textile structure to the delivery system may comprise placing a tubing around a bonding area. Bonding the shape-set textile structure to the delivery system may comprise soldering the shape-set textile structure to the cut hypotube. The delivery system may comprise a cut hypotube. The delivery system may comprise a hypotube including a first pattern and a second pattern.

**[0065]** In some embodiments, a method of manufacturing a thrombus treatment device comprises cutting a first pattern of longitudinally-spaced rows each including two kerfs and two stems into a hypotube and cutting a second pattern of longitudinally-spaced rows each including two kerfs and two stems into the hypotube. The two stems in each of the rows of the first pattern are circumferentially about 180° apart. The stems of the first pattern are offset in a first circumferential direction. The two stems in each of the rows of the second pattern are circumferentially about 180° apart. The stems of the second pattern are offset in a second circumferential direction opposite the first circumferential direction. The second pattern is singly alternatingly interspersed with the first pattern.

**[0066]** Cutting the first pattern and cutting the second pattern may comprise cutting rounded edges of the kerfs in each of the rows of the first pattern and the second pattern. Cutting the first pattern and cutting the second pattern may comprise cutting each of the rows of the first pattern and the second pattern at an angle with respect to a longitudinal axis of the hypotube. The hypotube may comprise stainless steel. The method may further comprise bonding the hypotube to a shape-set textile structure. The shape-set textile structure may include a plurality of bulbs.

**[0067]** In some embodiments, a method of treating a thrombus in a vessel comprises measuring a length of the thrombus in the vessel and advancing a microcatheter in the vessel. Advancing the microcatheter includes crossing the thrombus with a distal end of the microcatheter. The method further comprises inserting a thrombectomy device in a radially compressed state from an introducer sheath into the microcatheter. The thrombectomy device includes a textile structure including a plurality of filaments woven to form a plurality of self-expanding bulbs. At least two of the plurality of filaments comprise radiopaque material and configured to form crossing points visible under x-ray. The crossing points are configured to provide approximate length measurement of an expanded length of the thrombectomy device. The method further comprises, after inserting the thrombectomy device from the introducer sheath into the microcatheter, advancing the thrombectomy device in the vessel and through the microcatheter proximate to the distal end of the microcatheter. Advancing the thrombectomy device includes crossing the thrombus with the distal-most bulb of the plurality of self-expanding bulbs. The method further comprises, after advancing the thrombectomy device, retracting the microcatheter to unsheath a length of the thrombectomy device. Upon being unsheathed from the microcatheter, at least some of the plurality of self-expanding bulbs of the elongate support structure of the thrombectomy device self-expand from the radially compressed state to a radially expanded state. Retracting the microcatheter is at least until the length of the thrombectomy device is at least as long as the measured length of the thrombus in the vessel. The method further

comprises entrapping the thrombus in the unsheathed self-expanding bulbs, after entrapping the thrombus in the unsheathed self-expanding bulbs, removing the thrombus from the vessel in substantially one piece using the thrombectomy device, measuring a length of the thrombus out of the vessel, and comparing the length of the thrombus in the vessel to the length of the thrombus out of the vessel.

**[0068]** The method may further comprise, after retracting the microcatheter, torsionally rasping the thrombectomy device, wherein torsionally rasping the thrombectomy device may include entrapping the thrombus in the unsheathed self-expanding bulbs. The vessel may comprise a blood vessel in a brain, leg, or other vessel or structure in the body.

**[0069]** In some embodiments, a method of treating a thrombus in a vessel comprises measuring a length of the thrombus in the vessel and expanding a length of a thrombectomy device in the vessel proximate to the thrombus. The expanded length of the thrombectomy device is based at least partially on the measured length of the thrombus in the vessel.

**[0070]** Measuring the length of the thrombus in the vessel may comprise at least one of computerized axial tomography (CAT) scan digital imaging measurement, CAT scan angiogram, magnetic resonance imaging (MRI) angiogram, and catheter angiogram. Expanding the length of the thrombectomy device may include retracting a sheath from around the thrombectomy device. Retracting the sheath may be for a length greater than the expanded length of the thrombectomy device. The thrombectomy device may comprise a plurality of filaments woven into a textile structure. At least two of the plurality of filaments may include radiopaque material configured to form crossing points visible under x-ray. The crossing points may be configured to provide approximate length measurement of the expanded length of the thrombectomy device. The thrombectomy device may include a plurality of self-expanding bulbs. After expanding the length of the thrombectomy device, at least one of the plurality of self-expanding bulbs may be distal to the thrombus. After expanding the length of the thrombectomy device, at least two of plurality of bulbs may have different outer diameters. The method may further comprise removing the thrombus from the vessel in substantially one piece using the thrombectomy device, measuring a length of the thrombus out of the vessel, and comparing the length of the thrombus in the vessel to the length of the thrombus out of the vessel. The method may further comprise, if the length of the thrombus out of the vessel is less than the length of the thrombus in the vessel, removing remaining thrombus from the vessel. Measuring the length of the thrombus out of the vessel may comprise placing the thrombus proximate to a ruler on a package of the thrombectomy device. The vessel may comprise a blood vessel in a brain, leg, or other vessel or structure in the body.

**[0071]** In some embodiments, a method of treating a thrombus in a vessel comprises measuring a length of the thrombus in the vessel, removing the thrombus from the vessel in substantially one piece using a thrombectomy device, measuring a length of the thrombus out of the vessel, and comparing the length of the thrombus in the vessel to the length of the thrombus out of the vessel.

**[0072]** The method may further comprise, if the length of the thrombus out of the vessel is less than the length of the thrombus in the vessel, removing remaining thrombus from the vessel. Measuring the length of the thrombus in the vessel may comprise at least one of computerized axial tomography (CAT) scan digital imaging measurement, CAT scan angio-

gram, magnetic resonance imaging (MRI) angiogram, and catheter angiogram. Measuring the length of the thrombus out of the vessel may comprise placing the thrombus proximate to a ruler on a package of the thrombectomy device. The vessel may comprise a blood vessel in a brain, leg, or other vessel or structure in the body.

**[0073]** In some embodiments, a method of treating a thrombus in a vessel comprises advancing a microcatheter in the vessel including crossing a distal end of the thrombus with a distal end of the microcatheter, and, after advancing the microcatheter, inserting a thrombectomy device in a radially compressed state into the microcatheter. The thrombectomy device includes a plurality of wires woven to form a textile fabric including a first shape upon advancing out of the microcatheter and a second shape upon exposure to a temperature or lower. The method further comprises, after inserting the thrombectomy device into the microcatheter, advancing the thrombectomy device in the vessel and through the microcatheter proximate to the distal end of the microcatheter, and, after advancing the thrombectomy device, maintaining a location of a proximal portion of the thrombectomy device while proximally retracting the microcatheter. Upon being unsheathed from the microcatheter, the textile fabric changes from the radially compressed shape to the first shape. The method further comprises, after retracting the microcatheter, injecting fluid at the temperature or lower. Upon being contact with the temperature or lower, the textile fabric changes to the second shape. The method further comprises, while the textile structure is in the second shape, torsionally rasping the thrombectomy device, and, after torsionally rasping the thrombectomy device, retracting at a similar rate the microcatheter and the proximal portion of the thrombectomy device.

**[0074]** The first shape may comprise a plurality of bulbs and the second shape may comprise a spiral. The first temperature may be less than about 25° C. (e.g., about 18° C.). The textile fabric may include a third shape upon exposure to a second temperature or higher. The first shape may comprise an expanded cylinder, the second shape may comprise a spiral, and the third shape may comprise a plurality of bulbs. The second temperature may be greater than about 25° C. (e.g., about 37° C.). Torsionally rasping the thrombectomy device may include at least one of removing portions of the thrombus attached to an endothelium wall, entrapping the thrombus in the radially expanded distal portion of the thrombectomy device, and collecting emboli in the radially expanded distal portion of the thrombectomy device. The vessel may comprise a blood vessel in a brain, leg, or other vessel or structure in the body.

**[0075]** In some embodiments, a method of treating a thrombus in a vessel comprises advancing a thrombectomy device in a radially compressed state in the vessel and through a microcatheter until the thrombectomy is proximate to a distal end of the microcatheter and a distal end of the thrombus. The thrombectomy device includes a plurality of wires woven to form a textile fabric including a first shape upon advancing out of the microcatheter and a second shape upon exposure to a temperature or higher. The method further comprises, after advancing the thrombectomy device, maintaining a location of a proximal portion of the thrombectomy device while proximally retracting the microcatheter. Upon being unsheathed from the microcatheter, the textile fabric changes from the radially compressed shape to the first shape and wherein upon being exposed to the temperature or higher the

textile fabric changes from the first shape to the second shape. The method further comprises entrapping the thrombus in the second state.

**[0076]** The first shape may comprise a cylinder and the second shape may comprise a plurality of bulbs. The second shape may comprise at least two of the plurality of bulbs may have different outer diameters, different shapes, or different outer diameters and different shapes. The second shape may be tapered. The second shape may comprise at least two of the plurality of bulbs separated by a neck. The first shape may comprise a cylinder and the second shape may comprise a spiral. Entrapping the thrombus may include torsionally rasping the thrombectomy device. The vessel may comprise a blood vessel in a brain, leg, or other vessel or structure in the body.

**[0077]** In some embodiments, a method of treating a thrombus in a vessel comprises advancing a thrombectomy device in a radially compressed state in the vessel and through a microcatheter until the thrombectomy is proximate to a distal end of the microcatheter and a distal end of the thrombus. The thrombectomy device includes a first shape upon advancing out of the microcatheter, a second shape upon exposure to a first temperature or lower, and a third shape upon exposure to a second temperature or higher. The method further comprises, after advancing the thrombectomy device, maintaining a location of a proximal portion of the thrombectomy device while proximally retracting the microcatheter. Upon being unsheathed from the microcatheter, the thrombectomy device changes from the radially compressed shape to the first shape. The method further comprises, after retracting the microcatheter, injecting fluid at the temperature or lower. Upon contact with the first temperature or lower, the thrombectomy device changes to the second shape. The method further comprises, upon exposure to the second temperature or higher, the thrombectomy device changes to the third shape.

**[0078]** The thrombectomy device may comprise a textile structure including the first shape, the second shape, and the third shape. The thrombectomy device may comprise a laser cut structure including the first shape, the second shape, and the third shape. At least one of the first shape and the second shape may be non-cylindrical.

**[0079]** In some embodiments, a method of coupling a woven tubular device to a hypotube comprises inserting a proximal end of the woven tubular device into a distal end of the hypotube. The woven tubular device includes a plurality of self-expanding bulbs. The hypotube includes a plurality of kerfs. The method further comprises inserting a delivery device including a J-shaped tube proximate to the proximal end of the woven tubular device through a distal-most kerf of the plurality of kerfs, delivering solder from the delivery device at a first location and between the woven tubular structure and the hypotube, moving the delivery device to a second location circumferentially spaced about 180° from the first location, delivering solder from the delivery device at the second location and between the woven tubular structure and the hypotube, moving the delivery device to a third location circumferentially spaced about 90° from the first location and from the second location, delivering solder from the delivery device at the third location and between the woven tubular structure and the hypotube, moving the delivery device to a fourth location circumferentially spaced about 90° from the first location and from the second location and about 180° from the third location, delivering solder from the delivery

device at the fourth location and between the woven tubular structure and the hypotube, and allowing the solder to cool. The solder may comprise silver-based lead-free solder.

**[0080]** In some embodiments, a method of coupling a woven tubular device to a hypotube comprises inserting a proximal end of the woven tubular device into a distal end of the hypotube. The hypotube includes a plurality of kerfs. The method further comprises delivering bonding material from the delivery device between the woven tubular structure and the hypotube in at least one circumferential location. Delivering the solder includes inserting the delivery device including a J-shaped tube proximate to the proximal end of the woven tubular device through a distal-most kerf of the plurality of kerfs.

**[0081]** The bonding material may comprise at least one of solder and epoxy. The solder may comprise silver-based lead-free solder. The solder may comprise gold-based lead-free solder. Delivering the bonding material may include delivering the bonding material fully arcuately. Delivering the bonding material may include delivering the bonding material in a plurality of circumferentially spaced locations. Delivering the bonding material in the plurality of circumferentially spaced locations may include delivering bonding material from the delivery device at a first location and between the woven tubular structure and the hypotube, moving the delivery device to a second location circumferentially spaced about 180° from the first location, delivering bonding material from the delivery device at the second location and between the woven tubular structure and the hypotube, moving the delivery device to a third location circumferentially spaced about 90° from the first location and from the second location, delivering bonding material from the delivery device at the third location and between the woven tubular structure and the hypotube, moving the delivery device to a fourth location circumferentially spaced about 90° from the first location and from the second location and about 180° from the third location, and delivering bonding material from the delivery device at the fourth location and between the woven tubular structure and the hypotube. The proximal end of the woven tubular device may include a proximal segment including a sleeve around filaments of the woven tubular device and a distal segment including exposed filaments of the woven tubular device. The circumferential location may include at least parts of the proximal segment and the distal segment. The proximal end of the woven tubular device may include a first segment including a ring around filaments of the woven tubular device, a second segment distal to the first segment including exposed filaments of the woven tubular device, and a third segment proximal to the first segment including exposed filaments of the woven tubular device. The circumferential location may include at least parts of the first segment and at least one of the second segment and the third segment. The rings may be crimped around the filaments. The filaments may be welded to the ring.

**[0082]** In some embodiments, a method of coupling a woven tubular device to a hypotube comprises inserting a distal end of the hypotube into an interior of the woven tubular device at a longitudinal location and delivering bonding material between the woven tubular device and the hypotube at the longitudinal location.

**[0083]** The method may further comprise positioning a sleeve around the woven tubular device at the location. The bonding material may comprise at least one of solder and epoxy. After coupling, the distal end of the hypotube may be

proximate to a proximal end of the woven tubular device. After coupling, the distal end of the hypotube may be proximate to a distal end of the woven tubular device. The woven tubular device may include a plurality of bulbs. After coupling, the distal end of the hypotube may be proximate to a distal-most bulb.

**[0084]** In some embodiments, a method of manufacturing a thrombus treatment device comprises arranging a plurality of spools on spindles on a yarn wheel. At least some of the spools include radiopaque wires and at least some of the spools include shape memory wires. The method further comprises attaching an end of each of the wires to a ring over a first mandrel and braiding the radiopaque wires and the shape memory wires in a one-over-one-under-one pattern around the first mandrel to form a textile structure. Braiding includes at least one of rotating the yarn wheel, rotating the spindles, and longitudinally extending the ring along the first mandrel away from the yarn wheel. The method further comprises shape setting the textile structure into a substantially cylindrical shape, securing the shape-set textile structure on a second mandrel including bulbs and necks, shape setting the shape-set textile structure on the second mandrel, and removing the shape-set textile structure from the second mandrel.

**[0085]** Securing the shape-set textile structure on the second mandrel may include wrapping at least one of wire and bangles around the necks of the second mandrel. The method may further comprise forming the second mandrel. Forming the mandrel may include stringing bulbs along a wire. Stringing the bulbs along the wire may include selecting shapes of the bulbs, sizes of the bulbs, and spacing between the bulbs. Forming the mandrel may include stringing hypotubes along the wire and between at least some of the bulbs. Arranging the plurality of spools may include positioning at least two of the spools including radiopaque wires adjacent to each other. The method may further comprise bonding the shape-set textile structure to a hypotube.

**[0086]** In some embodiments, a method of manufacturing a thrombus treatment device comprises arranging a plurality of spools of wire on spindles on a yarn wheel, braiding the wires a mandrel including bulbs and necks to form a textile structure, shape setting the textile structure on the mandrel, and removing the shape-set textile structure from the mandrel.

**[0087]** The method may further comprise securing the textile structure on the mandrel before shape setting. The method may further comprise forming the mandrel. Forming the mandrel may include stringing bulbs along a wire. Stringing the bulbs along the wire may include selecting shapes of the bulbs, sizes of the bulbs, and spacing between the bulbs. Forming the mandrel may include stringing hypotubes along the wire and between at least some of the bulbs. The method may further comprise bonding the shape-set textile structure to a hypotube.

**[0088]** In some embodiments, a method of manufacturing a thrombus treatment device comprises arranging a plurality of spools on spindles on a yarn wheel. At least some of the spools include radiopaque wires and at least some of the spools include shape memory wires. Arranging the plurality of spools includes positioning at least two of the spools including radiopaque wires adjacent to each other. The method further comprises braiding the radiopaque wires and the shape memory wires to form a textile structure.

**[0089]** The textile structure may include two sine waves of radiopaque wires offset by about 180°. The textile structure may include three sine waves of radiopaque wires offset by

about 120°. The textile structure may include a first sine wave of radiopaque wires, a second sine wave of radiopaque wires offset from the first sine wave by about 180°, a third sine wave of radiopaque wires offset from the first sine wave by about 7.5°, and a fourth sine wave of radiopaque wires offset from the third sine wave by about 7.5°. The method may further comprise bonding the shape-set textile structure to a hypotube.

**[0090]** In some embodiments, a method of manufacturing a thrombus treatment device comprises holding a hypotube using at least one bushing and at least one collet and cutting a pattern including a plurality of kerfs into the hypotube. Cutting the pattern includes directing a focused laser beam at the hypotube and longitudinally and rotationally moving the hypotube in a design such that the focused laser beam cuts the hypotube to form the plurality of kerfs. The focused laser creates a heat impact puddle. The heat impact puddle is less than a width and a length of each of the plurality of kerfs. The method further comprises, during cutting the pattern, flowing fluid through the hypotube.

**[0091]** Directing the focused laser beam may include creating the heat impact puddle inward of edges of the plurality of kerfs. Cutting the pattern may include cutting away the heat impact puddle. Directing the focused laser beam may include creating the heat impact puddle at edges of the plurality of kerfs. Directing the focused laser beam may include creating the heat impact puddle at corners of the plurality of kerfs. The design may include outlining edges of the plurality of kerfs. The design may include moving the hypotube may include relatively moving the focused laser beam diagonal to the plurality of kerfs. The design may include a spiral. Holding the hypotube may comprise using at least one bushing comprising an aperture may have a diameter at least about 0.001 inches greater than an outer diameter of the hypotube. Holding the hypotube may comprise using at least one collet comprising an aperture may have a diameter at least about 0.001 inches greater than an outer diameter of the hypotube. Holding the hypotube may comprise adjusting a diameter of an aperture of the collet(s). Flowing the fluid may include adjusting a height of a reservoir containing the fluid. Flowing the fluid may include adjusting a height of a water inlet gate between a reservoir containing the fluid and the hypotube.

**[0092]** In some embodiments, a method of manufacturing a thrombus treatment device comprises cutting a pattern including a plurality of rows of kerfs into the hypotube. Cutting the pattern includes directing a focused laser beam at the hypotube and longitudinally and rotationally moving the hypotube such that the focused laser beam cuts the hypotube to form the plurality of kerfs. The focused laser creates a heat impact puddle. The heat impact puddle is inward of edges of the plurality of kerfs.

**[0093]** The method may further comprise flowing fluid through the hypotube. The method may further comprise holding a hypotube using at least one of a bushing and a collet.

**[0094]** In some embodiments, a method of manufacturing a thrombus treatment device comprises cutting a pattern into the hypotube and, during cutting the pattern, flowing fluid through the hypotube. The pattern includes a first pattern of longitudinally-spaced rows each including two kerfs and two stems and a second pattern of longitudinally-spaced rows each including two kerfs and two stems. The two stems in each of the rows of the first pattern are circumferentially about 180° apart. The stems of the first pattern are offset in a first circumferential direction. The two stems in each of the

rows of the second pattern are circumferentially about 180° apart. The rows of the second pattern are interspersed with the rows of the first pattern. The stems of the second pattern are offset in a second circumferential direction opposite the first circumferential direction.

**[0095]** Each of the rows may be angled with respect to a longitudinal axis of the hypotube. The kerfs in each of the rows of the first pattern and the second pattern may have rounded edges. A pitch of the longitudinally-spaced rows of the first pattern and the second pattern may vary longitudinally along the hypotube.

**[0096]** In some embodiments, a device for treating a thrombus in a vessel comprises a plurality of wires woven to form a self-expanding textile structure. The plurality of wires includes shape-memory wires and at least two radiopaque wires forming at two offset sine waves.

**[0097]** Crossings of the at least two sine waves may be substantially uniformly spaced. At least one of the at least two sine waves may include a plurality of radiopaque wires. Each of the at least two sine waves may include a plurality of radiopaque wires. The at least two sine waves may be offset by about 180°. The at least two sine waves may include three sine waves offset by about 120°. The textile structure may include a plurality of bulbs.

**[0098]** In some embodiments, a device for treating a thrombus in a vessel comprises a plurality of wires woven to form a textile structure including a plurality of bulbs. The textile structure includes a distal end including an end treatment.

**[0099]** The end treatment may comprise a polymer coating. The polymer may comprise radiopaque particles. The end treatment may comprise a radiopaque marker. The distal end may be radially inward of the plurality of bulbs.

**[0100]** In some embodiments, a device for treating a thrombus in a vessel comprises a plurality of wires woven to form a textile structure including a plurality of bulbs and necks between the bulbs. The necks are circumferentially offset around textile structure.

**[0101]** Each of the plurality of bulbs may have a generally circular cross-section in a radially expanded state. The necks may be aligned along chords of the bulbs. Each of the plurality of bulbs may have a generally spherical shape in a radially expanded state. The necks may be aligned along chords of the spheres. The necks may alternate about 180° between a first longitude and a second longitude. The necks may circumferentially rotate about 120° between each of the bulbs. The necks may circumferentially rotate about 90° between each of the bulbs. Each of the plurality of bulbs may have a generally polygonal cross-section in a radially expanded state. The necks may be aligned along apices of the bulbs.

**[0102]** In some embodiments, a device for treating a thrombus in a vessel comprises a plurality of wires woven to form a textile structure. The textile structure includes a first shape at a first temperature, a second shape at a second temperature higher than the first temperature, and a third shape including stress-induced martensite.

**[0103]** The third shape may comprise a cylindrical shape. The stress-induced martensite may be induced by inner side-walls of a sheath. The first shape may comprise a spiral. The second shape may comprise a plurality of bulbs. The first temperature may be less than about 25° C. (e.g., about 18° C.). The second temperature may be at least about 25° C. (e.g., about 37° C.).

**[0104]** In some embodiments, a device for treating a thrombus in a vessel comprises a plurality of wires woven to form a



textile structure. The textile structure includes a first shape at a first temperature, a second shape at a second temperature higher than the first temperature, and a third shape at a third temperature higher than the second temperature.

**[0105]** The second shape may comprise a cylindrical shape. The third shape may comprise a plurality of bulbs. The first shape may comprise a spiral. The first temperature may be less than about 25° C. (e.g., about 18° C.). The second temperature may be between about 25° C. and about 37° C. The third temperature may be at least about 37° C.

**[0106]** In some embodiments, a method of forming a device for treating a thrombus in a vessel comprises heat treating a structure to impart a first shape to the structure at a first temperature. The structure includes shape memory material. The method further comprises heat treating the structure to impart a second shape to the structure and heat treating the structure to impart a third shape to the structure.

**[0107]** The method may further comprise weaving a plurality of wires to form the structure, at least some of the plurality of wires including the shape memory material. The method may further comprise selecting temperatures of the heat treating based at least partially on a composition of the shape memory material. Heat treating the structure to impart the first shape may be at a temperature between about 400° C. and about 450° C. for about 2 minutes to about 10 minutes. Heat treating the structure to impart the second shape may be at a temperature between about 500° C. and about 550° C. for about 20 minutes to about 180 minutes. Heat treating the structure to impart the first shape may be at a temperature between about 400° C. and about 450° C. for about 3 minutes to about 10 minutes. Heat treating the structure to impart the first shape may be at a temperature between about 500° C. and about 550° C. for about 5 minutes to about 10 minutes. Heat treating the structure to impart the second shape may be at a temperature between about 400° C. and about 450° C. for about 3 minutes to about 10 minutes. Heat treating the structure to impart the first shape may be at a temperature between about 500° C. and about 550° C. for about 3 minutes to about 10 minutes. The second shape may comprise a plurality of bulbs. The third shape may comprise a spiral.

**[0108]** In some embodiments, a catheter comprises a hypotube including having a longitudinal axis. The hypotube includes a working lumen, a first pattern including a plurality of longitudinally-spaced rows each including two kerfs and two stems offset in a first circumferential direction, and a second pattern including a plurality of longitudinally-spaced rows each including two kerfs and two stems offset in a second circumferential direction opposite the first circumferential direction. The rows of the second pattern are singly alternatingly interspersed with the rows of the first pattern. A pitch of the longitudinally-spaced kerfs of first pattern and the second pattern vary along the longitudinal axis of the hypotube.

**[0109]** The hypotube may include a first section, a second section, a third section, a fourth section, a fifth section, and a sixth section. The first section may have a pitch of about 0.005 inches (approx. 0.13 mm). The second section may have a pitch of about 0.01 inches (approx. 0.25 mm). The third section may have a pitch of about 0.02 inches (approx. 0.51 mm). The fourth section may have a pitch of about 0.04 inches (approx. 1 mm). The fifth section may have a pitch of about 0.08 inches (approx. 2 mm). The sixth section may have a pitch of about 0.016 inches (approx. 4 mm). The first section may be a distal-most section of the hypotube. The first section

may be 20% of the hypotube. The second section may be proximal to the first section. The second section may be 15% of the hypotube. The third section may be proximal to the second section. The third section may be 15% of the hypotube. The fourth section may be proximal to the third section. The fourth section may be 15% of the hypotube. The fifth section may be proximal to the fourth section. The fifth section may be 15% of the hypotube. The sixth section may be proximal to the fifth section. The sixth section may be 20% of the hypotube. The first pattern and the second pattern may be laser-cut. The catheter may further comprise a polymer coating on at least a portion of an outside of the hypotube. At least one parameter of the polymer may vary along the longitudinal axis of the hypotube. The parameter(s) may be selected from the group consisting of one or more of: material, thickness, and durometer. The variation of parameter(s) of the polymer may be aligned with the variation of the pitch of the longitudinally-spaced kerfs. The catheter may further comprise a polymer coating on at least a portion of an inside of the hypotube. The hypotube may comprise stainless steel. The hypotube may comprise a shape memory material. Each of the kerfs may include rounded edges. Each of the rows may be at an angle with respect to the longitudinal axis of the hypotube.

**[0110]** In some embodiments, a catheter comprises a hypotube including having a longitudinal axis, a first polymer coating radially outward of at least a portion of an outside of the hypotube, and a second polymer coating radially inward of at least a portion of an inside of the hypotube. The hypotube includes at least one pattern including a plurality of longitudinally-spaced rows each including two kerfs and two stems offset in a first circumferential direction.

**[0111]** The first polymer may be different from the second polymer. At least one parameter of the first polymer coating may vary along the longitudinal axis of the hypotube. The parameter(s) may be selected from the group consisting of one or more of: material, thickness, and durometer. The pattern may include a first pattern including a plurality of longitudinally-spaced rows each including two kerfs and two stems offset in a first circumferential direction and a second pattern including a plurality of longitudinally-spaced rows each including two kerfs and two stems offset in a second circumferential direction opposite the first circumferential direction. The rows of the second pattern may be singly alternatingly interspersed with the rows of the first pattern. A pitch of the longitudinally-spaced kerfs may vary along the longitudinal axis of the hypotube.

**[0112]** In some embodiments, a catheter comprises a hypotube having a longitudinal axis and a polymer coating over at least a portion of an outside of the hypotube. The hypotube includes at least one pattern including a plurality of longitudinally-spaced rows each including two kerfs and two stems offset in a first circumferential direction. A pitch of the longitudinally-spaced kerfs varies along the longitudinal axis of the hypotube. At least one parameter of the polymer coating varies along the longitudinal axis of the hypotube. The parameter(s) may be selected from the group consisting of at least one of material, thickness, and durometer.

**[0113]** The variation of the parameter(s) of the polymer may be aligned with the variation of the pitch of the longitudinally-spaced kerfs. The polymer coating may be hydrophobic. The catheter may further comprise an inner polymer coating at least a portion of an inside of the hypotube.

**[0114]** In some embodiments, a system for heat treating a device comprises a chamber configured to contain bath media, a container within the chamber and configured to hold the device, an air inlet gate fluidly upstream of the chamber and configured to be coupled to a gas source to flow gas into the chamber to fluidize the bath media, a heating element between the air inlet gate and the chamber, and a porous plate between the air inlet gate and the chamber. The chamber includes a detachable flange. The container is mechanically coupled to the detachable flange.

**[0115]** The bath media may include sand. The bath media may include non-flammable particles. The porous plate may be between the heating element and the air inlet gate. The detachable flange may include a conduit configured to allow passage of an arm mechanically coupling the container and the detachable flange. Adjustment of a length of the arm may adjust a height of the container in the basket. Temperature in the chamber may vary vertically with distance from the heating device. The system may further comprise an air inflow regulator coupled to the air inlet gate. A height of the air inflow regulator may be adjustable to adjust a velocity of the gas into the chamber. The gas source may comprise nitrogen. The gas source may comprise air. The gas source may comprise hydrogen. The gas source may comprise carbon monoxide.

**[0116]** In some embodiments, a system for heat treating a device comprises a chamber configured to contain bath media, a container within the chamber and configured to hold the device, an air inlet gate fluidly upstream of the chamber and configured to be coupled to a gas source to flow gas into the chamber to fluidize the bath media, a heating element between the air inlet gate and the chamber, and a temperature regulator configured to regulate temperature in the chamber by adjusting at least one of the air inlet gate and the heating element. The system may further comprise thermal sensors electrically connected to the temperature regulator.

**[0117]** In some embodiments, a system for heat treating a device comprises a chamber configured to contain bath media, a container within the chamber and configured to hold the device, and an arm mechanically coupling the chamber to the detachable flange. Gas flow into the chamber is configured to fluidize the bath media. The chamber includes a detachable flange including a handle. A height of the container is adjustable in several embodiments.

**[0118]** The arm may comprise at least one of a wire, a plurality of wires, and a hypotube. Adjustment of a length of the arm may adjust the height of the container in the basket. Detachment of the detachable flange may allow removal of the container from the chamber. The system may further comprise air-sealant rivets on at least one of an inner surface of the detachable flange and an outer surface of the detachable flange.

**[0119]** In some embodiments, a system for cutting a hypotube comprises a laser configured to produce a focused laser beam, a bushing configured to at least partially support a hypotube, a collet configured to at least partially support the hypotube, a fluid flow system, and a conveyor system configured to longitudinally advance the hypotube. The collet includes an adjustable diameter aperture. The fluid flow system includes a water inlet device and a water inlet gate configured to be fluidly coupled to an end of the hypotube.

**[0120]** The focused laser beam may have a widest dimension less than a narrowest dimension of a pattern to be cut. The focused laser beam may have a widest dimension no more

than about 120% greater than a narrowest dimension of a pattern to be cut. The bushing may include an aperture may have a diameter at least about 0.001 inches (approx. 0.025 mm) greater than an outer diameter of the hypotube. The collet may include an aperture may have a diameter at least about 0.001 inches (approx. 0.025 mm) greater than an outer diameter of the hypotube. The water inlet device may have an adjustable height. The water inlet gate may have an adjustable height. The laser may comprise a YAG laser. The laser may have a wavelength of about 1060 nm or less.

**[0121]** In some embodiments, a system for cutting a hypotube comprises a fluid flow system, a conveyor system configured to longitudinally advance the hypotube, and at least one of a bushing and a collet configured to at least partially support the hypotube. The fluid flow system includes a water inlet device and a water inlet gate configured to be fluidly coupled to an end of the hypotube.

**[0122]** The collet may include an adjustable diameter aperture. The bushing may include an aperture may have a diameter at least about 0.001 inches (approx. 0.025 mm) greater than an outer diameter of the hypotube. The collet may include an aperture may have a diameter at least about 0.001 inches (approx. 0.025 mm) greater than an outer diameter of the hypotube. The water inlet device may have an adjustable height. The water inlet gate may have an adjustable height. A plurality of bushings and collets longitudinally may be spaced so that sag of the hypotube may be less than about 3% of a height of the hypotube.

**[0123]** In some embodiments, a system for cutting a hypotube comprises a fluid flow system including a water inlet device may have an adjustable height and a water inlet gate may have an adjustable height and configured to be fluidly coupled to an end of a hypotube. The water inlet device may include a plurality of reservoirs. The plurality of reservoirs may be vertically stacked and fluidly coupled. The water inlet gate may be configured to adjust fluid flow based on a height of the water inlet device.

**[0124]** The methods summarized above and set forth in further detail below describe certain actions taken by a practitioner; however, it should be understood that they can also include the instruction of those actions by another party. Thus, actions such as “advancing a guidewire” include “instructing the advancement of a guidewire.”

#### BRIEF DESCRIPTION OF THE DRAWINGS

**[0125]** FIG. 1A is a schematic side elevational view of an example embodiment of a vascular treatment device.

**[0126]** FIG. 1B is a schematic side elevational view of another example embodiment of a vascular treatment device.

**[0127]** FIG. 1C is a schematic side elevational view of yet another example embodiment of a vascular treatment device.

**[0128]** FIG. 1D is a schematic side elevational view of still another example embodiment of a vascular treatment device.

**[0129]** FIG. 2A is a schematic side elevational view of an example embodiment of a distal portion of a vascular treatment device.

**[0130]** FIG. 2B is a schematic side elevational view of another example embodiment of a distal portion of a vascular treatment device.

**[0131]** FIG. 2C is a perspective view of the distal portion of FIG. 2B.

**[0132]** FIG. 2D is a photograph illustrating the distal portion of FIG. 2B.

[0133] FIG. 3A is a schematic side elevational view of another example embodiment of a distal portion of a vascular treatment device.

[0134] FIG. 3B is a schematic side elevational view of another example embodiment of a distal portion of a vascular treatment device.

[0135] FIG. 3C is a perspective view of the distal portion of FIG. 3B.

[0136] FIG. 4A is a schematic side elevational view of another example embodiment of a distal portion of a vascular treatment device.

[0137] FIG. 4B is a schematic side elevational view of another example embodiment of a distal portion of a vascular treatment device.

[0138] FIG. 4C is a schematic side elevational view of another example embodiment of a distal portion of a vascular treatment device.

[0139] FIG. 4D is a schematic proximal end view of the distal portion of FIG. 4C.

[0140] FIG. 4E is a schematic side elevational view of yet another example embodiment of a distal portion of a vascular treatment device.

[0141] FIG. 4F is a schematic proximal end view of the distal portion of FIG. 4E.

[0142] FIG. 4G is a schematic side elevational view of yet another example embodiment of a distal portion of a vascular treatment device.

[0143] FIG. 4H is a schematic proximal end view of the distal portion of FIG. 4G.

[0144] FIG. 4I is a schematic side elevational view of still yet another example embodiment of a distal portion of a vascular treatment device.

[0145] FIG. 4J is a schematic side elevational view of another example embodiment of a distal portion of a vascular treatment device.

[0146] FIG. 4K is a schematic side elevational view of yet another example embodiment of a distal portion of a vascular treatment device.

[0147] FIG. 4L is a schematic side elevational view of still another example embodiment of a distal portion of a vascular treatment device.

[0148] FIG. 4M is a schematic side elevational view of still yet another example embodiment of a distal portion of a vascular treatment device.

[0149] FIG. 4N is a schematic side elevational view of an example square inch of an example embodiment of a distal portion of a vascular treatment device.

[0150] FIG. 5A is a schematic side elevational view of another example embodiment of a distal portion of a vascular treatment device.

[0151] FIG. 5B is a schematic side elevational view of yet another example embodiment of a distal portion of a vascular treatment device.

[0152] FIG. 5C is a schematic side elevational view of still another example embodiment of a distal portion of a vascular treatment device.

[0153] FIG. 5D is a schematic side elevational view of still yet another example embodiment of a distal portion of a vascular treatment device.

[0154] FIG. 5E is a schematic side elevational view of another example embodiment of a distal portion of a vascular treatment device.

[0155] FIG. 5F is a schematic side elevational view of yet another example embodiment of a distal portion of a vascular treatment device.

[0156] FIG. 5G is a schematic side elevational view of still another example embodiment of a distal portion of a vascular treatment device.

[0157] FIG. 6A is a schematic side elevational view of another example embodiment of a distal portion of a vascular treatment device.

[0158] FIG. 6B is a schematic side elevational view of yet another example embodiment of a distal portion of a vascular treatment device.

[0159] FIG. 6C is a schematic side elevational view of still another example embodiment of a distal portion of a vascular treatment device.

[0160] FIG. 6D is a schematic side elevational view of still yet another example embodiment of a distal portion of a vascular treatment device.

[0161] FIG. 6E is a schematic side elevational view of another example embodiment of a distal portion of a vascular treatment device.

[0162] FIG. 6F is a schematic side elevational view of yet another example embodiment of a distal portion of a vascular treatment device.

[0163] FIG. 6G is a schematic side elevational view of still another example embodiment of a distal portion of a vascular treatment device.

[0164] FIG. 6H is a schematic side elevational view of still yet another example embodiment of a distal portion of a vascular treatment device.

[0165] FIG. 6I is a schematic side elevational view of another example embodiment of a distal portion of a vascular treatment device.

[0166] FIG. 6J is a schematic side elevational view of yet another example embodiment of a distal portion of a vascular treatment device.

[0167] FIG. 7A is a schematic side elevational view of still another example embodiment of a distal portion of a vascular treatment device.

[0168] FIG. 7B is a schematic side elevational view of still yet another example embodiment of a distal portion of a vascular treatment device.

[0169] FIG. 7C is a schematic side elevational view of another example embodiment of a distal portion of a vascular treatment device.

[0170] FIG. 7D is a schematic side elevational view of yet another example embodiment of a distal portion of a vascular treatment device.

[0171] FIG. 7E is a schematic side elevational view of still another example embodiment of a distal portion of a vascular treatment device.

[0172] FIG. 8A is a schematic side perspective view of an example embodiment of a braiding device.

[0173] FIG. 8B is a schematic diagram illustrating an example setup of a braid carrier mechanism.

[0174] FIG. 8C is a schematic diagram illustrating a magnified view of three pairs of spindles in the example setup of the braid carrier mechanism of FIG. 8B.

[0175] FIG. 8D is a photograph illustrating a plurality of filaments being braided on a mandrel.

[0176] FIG. 8E is a schematic side elevational view of another example embodiment of a distal portion of a vascular treatment device.

[0177] FIG. 8F is a schematic side elevational view of the distal portion of FIG. 8E illustrating an example pattern of radiopaque filaments.

[0178] FIG. 8G is a schematic diagram illustrating an example setup of a braid carrier mechanism for forming the distal portion of FIG. 8E.

[0179] FIG. 8H is a schematic side elevational view of another example embodiment of a distal portion of a vascular treatment device illustrating an example pattern of radiopaque filaments.

[0180] FIG. 8I is a schematic diagram illustrating an example setup of a braid carrier mechanism for forming the distal portion of FIG. 8H.

[0181] FIG. 8J is a schematic side elevational view of yet another example embodiment of a distal portion of a vascular treatment device illustrating an example pattern of radiopaque filaments.

[0182] FIG. 8K is a schematic diagram illustrating an example setup of a braid carrier mechanism for forming the distal portion of FIG. 8J.

[0183] FIG. 8L is an x-ray photograph illustrating an example of a plurality of radiopaque filaments of the distal portion of FIG. 8J.

[0184] FIG. 8M is a schematic side elevational view of still another example embodiment of a distal portion of a vascular treatment device illustrating an example pattern of radiopaque filaments.

[0185] FIG. 8N is a schematic diagram illustrating an example setup of a braid carrier mechanism for forming the distal portion of FIG. 8M.

[0186] FIG. 8O is a photograph illustrating a plurality of radiopaque filaments of the distal portion of FIG. 8M on a mandrel.

[0187] FIG. 8P is a schematic side elevational view of yet another example embodiment of a distal portion of a vascular treatment device illustrating an example pattern of radiopaque filaments.

[0188] FIG. 8Q is a magnified view of the radiopaque filaments of the distal portion of FIG. 8P.

[0189] FIG. 8R is a schematic diagram illustrating an example setup of a braid carrier mechanism for forming the distal portion of FIG. 8P.

[0190] FIG. 8S is an x-ray photograph illustrating an example of a plurality of radiopaque filaments of the distal portion of FIG. 8P.

[0191] FIG. 8T-1 is a schematic side elevational view of still yet another example embodiment of a distal portion of a vascular treatment device illustrating an example pattern of radiopaque filaments.

[0192] FIG. 8T-2 is a schematic side elevational view of another example embodiment of a distal portion of a vascular treatment device illustrating an example pattern of radiopaque filaments.

[0193] FIG. 8T-3 is a schematic diagram illustrating an example setup of a braid carrier mechanism for forming the distal portions of FIGS. 8T-1 and 8T-2.

[0194] FIG. 8T-4 is an x-ray photograph illustrating an example of a plurality of radiopaque filaments of the distal portion of FIG. 8T-2.

[0195] FIG. 8U is a schematic side elevational view of another example embodiment of a distal portion of a vascular treatment device illustrating an example pattern of radiopaque filaments.

[0196] FIG. 8V is a schematic diagram illustrating an example setup of a braid carrier mechanism for forming the distal portion of FIG. 8U.

[0197] FIG. 8W is a magnified view of the distal portion of FIG. 8U.

[0198] FIG. 8X is a schematic side elevational view of yet another example embodiment of a distal portion of a vascular treatment device illustrating an example pattern of radiopaque filaments.

[0199] FIG. 8Y is a schematic diagram illustrating an example setup of a braid carrier mechanism for forming the distal portion of FIG. 8X.

[0200] FIG. 8Z is a magnified view of the distal portion of FIG. 8X.

[0201] FIG. 9A is a schematic magnified side elevational view of a portion of another example embodiment of a distal portion of a vascular treatment device illustrating an example pattern of one or more filaments.

[0202] FIG. 9B is a schematic side elevational view of an example embodiment of forming the distal portion of FIG. 9A.

[0203] FIG. 9C is a schematic diagram illustrating still another example setup of a braid carrier mechanism for forming the distal portion of FIG. 9B.

[0204] FIG. 9D is a schematic diagram illustrating yet another example setup of a braid carrier mechanism for forming the distal portion of FIG. 9B.

[0205] FIG. 9E is a schematic diagram illustrating an example embodiment of a mandrel for heat treatment of a distal portion of a vascular treatment device.

[0206] FIG. 9F is a schematic diagram illustrating another example embodiment of a mandrel for heat treatment of a distal portion of a vascular treatment device.

[0207] FIG. 10A is a photograph illustrating an example woven tubular structure after being removed from a mandrel.

[0208] FIG. 10B is another photograph illustrating an example woven tubular structure after being removed from a mandrel.

[0209] FIG. 10C is schematic exploded side elevational view of an example embodiment of a mandrel.

[0210] FIG. 10D is a photograph showing a side elevational view of an example embodiment of a mandrel.

[0211] FIG. 10E is a schematic side elevational view illustrating an example embodiment of a woven tubular structure around a mandrel.

[0212] FIG. 10F is a photograph illustrating an example embodiment of a woven tubular structure around a mandrel.

[0213] FIG. 10G is a schematic side elevational view of another example embodiment of a woven tubular structure around a mandrel.

[0214] FIG. 10H is a schematic side elevational view of an example embodiment of a woven tubular structure having a transition angle.

[0215] FIG. 10I is a schematic side elevational view of another example embodiment of a woven tubular structure having a transition angle.

[0216] FIG. 10J is a schematic side elevational view of another example embodiment of a woven tubular structure around a mandrel.

[0217] FIG. 10K is a schematic side elevational view of yet another example embodiment of a woven tubular structure around a mandrel.

[0218] FIG. 10L is a schematic side elevational view of an example embodiment of removal of a mandrel from within a woven tubular structure.

[0219] FIG. 10M is a schematic partial cut away side view of an example embodiment of a heat treatment device.

[0220] FIG. 11A is a schematic side elevational view of an example embodiment of braiding around a mandrel.

[0221] FIG. 11B is a schematic side elevational view of another example embodiment of braiding around a mandrel.

[0222] FIG. 11C is a schematic side elevational view of an example embodiment of forming a textile structure.

[0223] FIG. 11D is a schematic side elevational view of another example embodiment of braiding around of forming a textile structure.

[0224] FIG. 11E is perspective view of an example embodiment of a distal portion of a vascular treatment device.

[0225] FIG. 12A is a schematic perspective view of an example embodiment of a filament end treatment of a distal portion of a vascular treatment device.

[0226] FIG. 12B is a front elevational view of the filament end treatment of FIG. 12A.

[0227] FIG. 12C is a schematic perspective view of another example embodiment of a filament end treatment of a distal portion of a vascular treatment device.

[0228] FIG. 12D is a front elevational view of the filament end treatment of FIG. 12C.

[0229] FIG. 12E is a schematic perspective view of yet another example embodiment of a filament end treatment of a distal portion of a vascular treatment device.

[0230] FIG. 12F is a schematic perspective view of still another example embodiment of a filament end treatment.

[0231] FIG. 13A is a photograph illustrating an example embodiment of a plurality of filaments being knitted into an example biomedical textile structure.

[0232] FIG. 13B is a photograph illustrating an example embodiment of a plurality of filaments being woven into another example biomedical textile structure.

[0233] FIG. 14A is a photograph of an example of a segment of an example embodiment of a proximal portion of a vascular treatment device.

[0234] FIG. 14B is a photograph of another example segment of an example embodiment of a proximal portion of a vascular treatment device.

[0235] FIG. 14C is a schematic front elevational view of yet another example embodiment of a proximal portion of a vascular treatment device.

[0236] FIG. 14D is a schematic side partial cross-sectional view of an example embodiment of a balloon catheter.

[0237] FIG. 15A is a schematic diagram illustrating an example embodiment of a cut pattern.

[0238] FIG. 15B is a schematic diagram illustrating an example embodiment of a portion of a cut pattern.

[0239] FIG. 15C is a schematic diagram illustrating another example embodiment of a portion of a cut pattern.

[0240] FIG. 15D is a schematic diagram illustrating an example embodiment of staggered interspersed cut patterns.

[0241] FIG. 15E is a schematic diagram illustrating an example embodiment of staggered interspersed offset cut patterns.

[0242] FIG. 16A is a schematic diagram illustrating an example embodiment of an angled pattern including sharp edges.

[0243] FIG. 16B is a schematic diagram illustrating an example embodiment of an angled pattern including rounded edges.

[0244] FIG. 16C is a schematic diagram illustrating an example embodiment of interspersed offset horizontal patterns including sharp edges.

[0245] FIG. 16D is a schematic diagram illustrating an example embodiment of interspersed offset horizontal patterns including rounded edges.

[0246] FIG. 16E is a schematic diagram illustrating an example embodiment of slits and stems along the length of an example embodiment of a proximal portion of a vascular treatment device.

[0247] FIG. 16F is a schematic diagram illustrating another example embodiment of slits and stems along the length of an example embodiment of a proximal portion of a vascular treatment device.

[0248] FIG. 17A is a schematic diagram illustrating an example embodiment of a laser cutting system.

[0249] FIG. 17B is a schematic diagram illustrating an example embodiment of cut design of a slit.

[0250] FIG. 17C is a schematic diagram illustrating an example embodiment of an interspersed offset horizontal pattern including slits and heat impact puddles.

[0251] FIG. 17D is a schematic diagram illustrating another example embodiment of a cut design of a slit.

[0252] FIG. 17E is a schematic diagram illustrating yet another example embodiment of a cut design of a slit.

[0253] FIG. 17F is a schematic diagram illustrating still another example embodiment of a cut design of a slit.

[0254] FIG. 17G is a schematic diagram illustrating still yet another example embodiment of a cut design of a slit.

[0255] FIG. 17H is a schematic side elevational view of an example embodiment of a bushing.

[0256] FIG. 17I is a schematic cross-sectional front elevational view of the bushing of FIG. 17H along the line 17I-17I.

[0257] FIG. 17J is a schematic side elevational view of an example embodiment of a collet.

[0258] FIG. 17K is a schematic cross-sectional front elevational view of the collet of FIG. 17J along the line 17K-17K.

[0259] FIG. 17L is a schematic diagram illustrating an example embodiment of an arrangement of bushings and collets.

[0260] FIG. 17M is a schematic diagram illustrating an example embodiment of the sag of a hypotube in an arrangement of bushings and collets.

[0261] FIG. 17N is a schematic diagram illustrating an example embodiment of a water inlet device.

[0262] FIG. 18A is a schematic perspective view of an example embodiment of a proximal portion of a vascular treatment device comprising a plurality of filaments.

[0263] FIG. 18B is a schematic front perspective view of the proximal portion of FIG. 18A.

[0264] FIG. 18C is a schematic perspective view of another example embodiment of a proximal portion of a vascular treatment device comprising a plurality of filaments.

[0265] FIG. 18D is a schematic side elevational view of an example embodiment of a proximal portion of a vascular treatment device illustrating an example pattern of radio-opaque filaments.

[0266] FIG. 18E is a schematic front elevational view of the proximal portion of FIG. 18D.

[0267] FIG. 18F is a schematic side elevational view of another example embodiment of a proximal portion of a vascular treatment device illustrating an example pattern of radiopaque filaments.

[0268] FIG. 18G is a schematic front elevational view of the proximal portion of FIG. 18F.

[0269] FIG. 18H is a schematic side elevational view of still another example embodiment of a proximal portion of a vascular treatment device illustrating an example pattern of radiopaque filaments.

[0270] FIG. 18I is a schematic front elevational view of the proximal portion of FIG. 18H.

[0271] FIG. 18J is a schematic side elevational view of yet another example embodiment of a proximal portion of a vascular treatment device illustrating an example pattern of radiopaque filaments.

[0272] FIG. 18K is a schematic front elevational view of the proximal portion of FIG. 18J.

[0273] FIG. 18L is a schematic side elevational view of still yet another example embodiment of a proximal portion of a vascular treatment device illustrating an example pattern of radiopaque filaments.

[0274] FIG. 18M is a schematic front elevational view of the proximal portion of FIG. 18L.

[0275] FIG. 18N is a schematic side elevational view of another example embodiment of a proximal portion of a vascular treatment device comprising a plurality of filaments.

[0276] FIG. 19A is a schematic diagram illustrating an example embodiment of variation of slits along the length of an example embodiment of a proximal portion of a vascular treatment device.

[0277] FIG. 19B is a schematic diagram illustrating an example embodiment of variation of slits and radiopaque markers along the length of an example embodiment of a proximal portion of a vascular treatment device.

[0278] FIG. 19C is a schematic diagram illustrating still another example embodiment of a proximal portion of a vascular treatment device.

[0279] FIG. 19D is a schematic partial cut away side view of another example embodiment of a heat treatment device.

[0280] FIG. 19E is a schematic partial cut away side view of a portion of the heat treatment device of FIG. 19D.

[0281] FIG. 19F is a schematic diagram illustrating still yet another example embodiment of a proximal portion of a vascular treatment device.

[0282] FIG. 20A is a schematic diagram illustrating an example embodiment of a joint between a proximal portion and a distal portion.

[0283] FIG. 20B is a schematic cross-section of the joint of FIG. 20A along the line 20B-20B.

[0284] FIG. 20C is a schematic cross-section illustrating an example embodiment of filament area in comparison to tube area.

[0285] FIGS. 20D-20F schematically illustrate a method of coupling a braided tube to a hypotube.

[0286] FIG. 21A is a schematic diagram illustrating another example embodiment of a joint between a proximal portion and a distal portion.

[0287] FIG. 21B is a schematic cross-section of the joint of FIG. 21A along the line 21B-21B.

[0288] FIG. 21C is a photograph illustrating the inlay bonding approach of FIG. 21.

[0289] FIG. 22A is a schematic diagram illustrating yet another example embodiment of a joint between a proximal portion and a distal portion.

[0290] FIG. 22B is a schematic cross-section of the joint of FIG. 22A along the line 22B-22B.

[0291] FIG. 23A is a schematic diagram illustrating still another example embodiment of a joint between a proximal portion and a distal portion.

[0292] FIG. 23B is a schematic cross-section of the joint of FIG. 23A along the line 23B-23B.

[0293] FIG. 23C is a schematic cross-section of the joint 300 of FIG. 23A along the line 23C-23C.

[0294] FIG. 24A is a schematic diagram illustrating another example embodiment of a joint between a proximal portion and a distal portion.

[0295] FIG. 24B is a schematic diagram illustrating yet another example embodiment of a joint between a proximal portion and a distal portion.

[0296] FIG. 24C is a schematic diagram showing the joints of FIGS. 24A and 24B.

[0297] FIG. 24D is a schematic diagram illustrating yet another example embodiment of a joint between a proximal portion and a distal portion.

[0298] FIG. 25A-1 is a schematic diagram illustrating an example embodiment of a mechanical detachment system.

[0299] FIG. 25A-2 is a schematic diagram illustrating an example embodiment of the components of the mechanical detachment system of FIG. 25A-1.

[0300] FIG. 25B is a schematic diagram of a partial cross-sectional view of an example embodiment of a mechanical detachment system.

[0301] FIG. 25C is a schematic diagram of a partial cross-sectional view of another example embodiment of a mechanical detachment system.

[0302] FIG. 25D is a schematic diagram of a partial cross-sectional view of yet another example embodiment of a mechanical detachment system.

[0303] FIG. 25E is a schematic diagram of a partial cross-sectional view of still another example embodiment of a mechanical detachment system.

[0304] FIG. 26A is a schematic diagram illustrating still another example embodiment of a joint between a proximal portion and a distal portion.

[0305] FIG. 26B is a schematic diagram illustrating yet still another example embodiment of a joint between a proximal portion and a distal portion.

[0306] FIG. 26C is a schematic diagram illustrating another example embodiment of a joint between a proximal portion and a distal portion.

[0307] FIG. 27A is a schematic diagram of a guide catheter proximal to a clot in vasculature.

[0308] FIG. 27B is a schematic diagram of a microwire distal to a clot in vasculature and a microcatheter over the microwire.

[0309] FIG. 27C is an expanded view of FIG. 27B in the area of the clot.

[0310] FIG. 27D is a schematic diagram of a microcatheter distal to a clot in vasculature.

[0311] FIG. 27E is a schematic diagram illustrating an example embodiment of the distal portion of a vascular treatment device being introduced into the hub of a microcatheter through an introducer sheath.

[0312] FIG. 27F is a schematic partial cross-sectional view of an example embodiment of a distal portion of a vascular treatment device within an introducer sheath.

[0313] FIG. 27G is a schematic diagram of part of a distal portion of a vascular treatment device being deployed distal to a clot in vasculature.

[0314] FIG. 27H is a schematic diagram of a distal portion of a vascular treatment device being deployed across a clot in vasculature.

[0315] FIG. 27I-1 is a schematic diagram illustrating an example embodiment of the distal portion of a vascular treatment device being used in conjunction with thrombus aspiration.

[0316] FIG. 27I-2 is a table schematically illustrating an example embodiment of crescendo suction patterns for aspiration.

[0317] FIG. 27J is a schematic diagram of a distal portion of a vascular treatment device illustrating longitudinal bunching of filaments during deployment.

[0318] FIG. 27K is a schematic diagram of a distal portion of a vascular treatment device being torsionally rasped.

[0319] FIG. 27L is a schematic diagram illustrating an example embodiment of a two-way shape memory effect of a distal portion of a vascular treatment device.

[0320] FIG. 27M is a schematic diagram illustrating the retraction of a distal portion of a vascular treatment device and a clot.

[0321] FIG. 27N illustrates an example embodiment of a comparison of a clot length to a ruler.

[0322] FIG. 27O is a schematic diagram of a distal portion of a thrombectomy device acting as a filter device.

[0323] FIG. 27P is a schematic diagram illustrating an example embodiment of a two-way shape memory effect of the proximal portion of a thrombectomy device.

[0324] FIG. 28A is a schematic diagram of a guide catheter proximal to an aneurysm in vasculature.

[0325] FIGS. 28B and 28C are schematic diagrams of a microwire distal to an aneurysm in vasculature and a microcatheter over the microwire.

[0326] FIG. 28D is a schematic diagram of a microcatheter distal to an aneurysm in vasculature.

[0327] FIG. 28E is a schematic diagram of an example embodiment of the distal portion of a vascular treatment device being deployed distal to an aneurysm in vasculature.

[0328] FIG. 28F is a schematic diagram of an example embodiment of the distal portion of a vascular treatment device being deployed across an aneurysm in vasculature.

[0329] FIG. 28G is a schematic diagram of an example embodiment of the distal portion of FIG. 6G deployed across an aneurysm in vasculature.

[0330] FIG. 28H is a schematic diagram of an example embodiment of the distal portion of FIG. 7B deployed across an aneurysm in vasculature.

[0331] FIG. 28I is a schematic diagram of an example embodiment of the distal portion of FIG. 6A deployed across an aneurysm in vasculature.

[0332] FIG. 28J is a schematic diagram of an example embodiment of the distal portion of FIG. 6B deployed across an aneurysm in vasculature.

[0333] FIG. 28K is a schematic diagram of an example embodiment of the distal portion of FIG. 6C deployed across an aneurysm in vasculature.

[0334] FIG. 28L is a schematic diagram of an example embodiment of the distal portion of FIG. 6D deployed across aneurysms in vasculature.

[0335] FIG. 28M is a schematic diagram of an example embodiment of the distal portion of FIG. 6E deployed across an aneurysm in vasculature.

[0336] FIG. 28N is a schematic diagram of an example embodiment of the distal portion of FIG. 6F deployed across an aneurysm in vasculature.

[0337] FIG. 28O is a schematic diagram of an example embodiment of the distal portion of FIG. 7A deployed across a bifurcation aneurysm in vasculature.

[0338] FIG. 28P is a schematic diagram of an example embodiment of the distal portion of FIG. 6H deployed across a side-wall aneurysm in vasculature.

[0339] FIG. 28Q is a schematic diagram of an example embodiment of the distal portion of FIG. 6J deployed across a vascular malformation in vasculature.

[0340] FIG. 29A is a schematic diagram of an example embodiment of the distal portion of FIG. 7C deployed across a fistula.

[0341] FIG. 29B is a schematic diagram of an example embodiment of the distal portion of FIG. 7D deployed in a cardiac wall aneurysm.

[0342] FIG. 29C is a schematic diagram of an example embodiment of the distal portion of FIG. 7E deployed in the left atrial appendage of the heart.

#### DETAILED DESCRIPTION

[0343] FIG. 1A is a schematic side elevational view of an example embodiment of a vascular treatment device 10. The device 10 includes a distal portion 100, a proximal portion 200, and a joint 300 coupling the distal portion 100 to the proximal portion 200. In the device 10, the joint 300 couples a proximal segment of the distal portion 100 to a distal segment of the proximal portion 200.

[0344] FIG. 1B is a schematic side elevational view of another example embodiment of a vascular treatment device 20. The device 20 includes a distal portion 100, a proximal portion 200, and a joint 300 coupling the distal portion 100 to the proximal portion 200. In the device 20, the joint 300 couples a distal segment of the distal portion 100 to a distal segment of the proximal portion 200. The proximal portion 200 extends through the distal portion 100.

[0345] FIG. 1C is a schematic side elevational view of yet another example embodiment of a vascular treatment device 30. The device 30 includes a distal portion 100, a proximal portion 200, and a joint 300 coupling the distal portion 100 to the proximal portion 200. In the device 30, the joint 300 couples a segment between the proximal end and distal the end of the distal portion 100 to a distal segment of the proximal portion 200. The proximal portion 200 partially extends through the distal portion 100.

[0346] FIG. 1D is a schematic side elevational view of still another example embodiment of a vascular treatment device 40. The device 40 includes a distal portion 100, a proximal portion 200, and a joint 300 coupling the distal portion 100 to the proximal portion 200. In the device 40, the joint 300 couples the distal portion 100 to a segment of the proximal portion 200 that is proximal to the distal end of the proximal portion 200. The distal end of the proximal portion 200 extends beyond the distal end of the distal portion 100.

[0347] For each of the devices 10, 20, 30, 40, a wide variety of distal portions 100, proximal portions 200, and joints 300

are possible, including the distal portions **100**, proximal portions **200**, and joints **300** described herein. In some embodiments, the distal portion **100** includes a plurality of woven bulbs spaced longitudinally apart by woven necks. In some embodiments, the proximal portion **200** includes a cut hypotube having variable longitudinal flexibility. Other varieties of distal portions **100** and proximal portions **200** are also possible. In some embodiments, the distal portion **100** comprises a shape-set textile structure, the proximal portion **200** comprises a delivery system or hypotube, and the joint **300** comprises a bonding zone in a marker band region. In some embodiments, coupling the distal portion **100** and the proximal portion **200** at the joint **300** may be fixed or reversible.

[0348] In some embodiments, the distal portion **100** in a radially-collapsed configuration has an outer diameter of about 0.0125 inches (approx. 0.317 mm) or less and in a radially-expanded configuration has varying diameters. In some embodiments, the distal portion **100** in the radially-collapsed configuration has a diameter in the range of about 0.1 mm to about 0.9 mm (e.g., about 0.25 mm to about 0.5 mm). In some embodiments, the distal portion **100** in the radially-expanded configuration has a diameter in the range of about 1 mm to about 6.5 mm (e.g., about 3 mm to about 4.5 mm). In some embodiments, for example embodiments in which the distal portion **100** is configured or intended for use in larger vessels or bodily conduits, the distal portion **100** in the radially-expanded configuration has a diameter in the range of about 5 mm to about 40 mm and a diameter in the radially-collapsed configuration in the range of about 0.5 mm to about 5 mm. In some embodiments, the ratio of the diameter of the distal portion **100** in the radially-expanded configuration to the diameter of the distal portion **100** in the radially-collapsed configuration is about 1.2:1 to about 100:1 (e.g., about 1.2:1 to about 20:1, about 9:1 to about 15:1).

[0349] FIG. 2A is a schematic side elevational view of an example embodiment of a distal portion **1000** of a vascular treatment device, for example the distal portion **100** of the device **10**, **20**, **30**, or **40**. The distal portion **1000** includes a plurality of woven bulbs **1010** and woven necks **1020**. The distal portion **1000** includes a woven neck **65** at the distal end. A radiopaque marker band **25** is coupled to the distal end of the proximal portion **200**, discussed in further detail herein. The bulbs **1010** are longitudinally spaced from each other by the woven necks **1020**. In some embodiments, the bulbs **1010** and the necks **1020** are an integral textile structure in which the filaments that form the bulbs **1010** are the same as and longitudinally continuous with the filaments that form the necks **1020**. The bulbs **1010** are generally spherical or spheroid, although the proximal and distal ends of the bulbs **1010** may begin to form the necks **1020**. The bulbs **1010** extend radially outward from the longitudinal axis, increasing in diameter from proximal to distal, reaching an intermediate point, and then decreasing in diameter from proximal to distal. The necks **1020** are cylindrical or generally cylindrical along the longitudinal axis, although the ends of the necks **1020** may flare outwardly to begin to form the bulbs **1010**. The bulbs **1010** in FIG. 2A have substantially uniform dimensions or diameters (e.g., within about  $\pm 5\%$ , about  $\pm 10\%$ , about  $\pm 15\%$ , or about 20% of each other) such that the distal portion **1000** may be considered non-tapered or cylindrical.

[0350] FIG. 2B is a schematic side elevational view of another example embodiment of a distal portion **1100** of a vascular treatment device, for example the distal portion **100** of the device **10**, **20**, **30**, or **40**. FIG. 2C is a perspective view

of the distal portion **1100** of FIG. 2B. FIG. 2D is a photograph illustrating the distal portion **1100** of FIG. 2B. The distal portion **1100** includes a plurality of woven bulbs **1110** and woven necks **1120**. The distal portion **1100** includes a woven neck **65** at the distal end. A radiopaque marker band **25** is coupled to the distal end of the proximal portion **200**, discussed in further detail herein. The bulbs **1110** are longitudinally spaced from each other by the woven necks **1120**. In some embodiments, the bulbs **1110** and the necks **1120** are an integral textile structure in which the filaments that form the bulbs **1110** are the same as and longitudinally continuous with the filaments that form the necks **1120**. The bulbs **1110** are generally spherical or spheroid, although the proximal and distal ends of the bulbs **1110** may begin to form the necks **1120**. The bulbs **1110** extend radially outward from the longitudinal axis, increasing in diameter from proximal to distal, reaching an intermediate point, and then decreasing in diameter from proximal to distal. The necks **1120** are cylindrical or generally cylindrical along the longitudinal axis, although the ends of the necks **1120** may flare outwardly to begin to form the bulbs **1110**.

[0351] The distal portion **1100** includes ten bulbs **1110**: three bulbs **1112**, three bulbs **1114**, two bulbs **1116**, and two bulbs **1118**. The bulbs **1112** have a smaller diameter than the bulbs **1114**, which have a smaller diameter than the bulbs **1116**, which have a smaller diameter than the bulbs **1118**. The bulbs **1112** have substantially uniform diameters, the bulbs **1114** have substantially uniform diameters, the bulbs **1116** have substantially uniform diameters, and the bulbs **1118** have substantially uniform diameters. Due to the differing diameters of the bulbs **1110**, the distal portion **1100** may be considered tapered, for example inwardly tapered from proximal to distal or outwardly tapered from distal to proximal, or the distal portion **1100** may be considered stepped, for example inwardly stepped from proximal to distal or outwardly stepped from distal to proximal. Other and opposite configurations are also possible. For example, the bulbs **1110** may be inwardly tapered or stepped from distal to proximal or outwardly stepped from proximal to distal. For another example, the bulbs **1110** may have random (e.g., non-sequential) diameters along the length of the distal portion **1100**, which may include sections that are substantially cylindrical and/or sections that are stepped or tapered distally and/or proximally.

[0352] In some embodiments, the outer diameters of the bulbs **1110** in the radially-expanded configuration are as follows: the three distal extra-small spherical bulbs **1112** have an outer diameter configured to be oversized to the extra-small vessel segments such as the M2 segments of the middle cerebral artery (e.g., about 1.5 mm to about 2.25 mm); the proximally-next three small spherical bulbs **1114** have an outer diameter configured to be oversized to the smaller vessel segments such as the distal M1 segment of the middle cerebral artery (e.g., about 2.25 mm to about 2.75 mm); the proximally-next two medium spherical bulbs **1116** have an outer diameter configured to be oversized to the medium vessel segments such as the proximal M1 segment of the middle cerebral artery (e.g., about 2.75 mm to about 3.25 mm); and the proximal two large spherical bulbs **1118** have an outer diameter configured to be oversized to the large vessel segments such as the distal supraclinoid segment of the internal carotid artery (e.g., about 3.25 mm to about 4 mm). A tapered configuration of the distal portion **1100** can allow for adequate and safe deployment of the distal portion **1100**



across blood vessels with multiple and/or varying diameters (e.g., vasculature that progressively reduces in size). Although some example diameters are provided herein, some embodiments of the distal portion 1100 may include diameters of the bulbs 1112, 1114, 1116, 1118 in accordance with the values provided above and/or diameters that are within about  $\pm 5\%$ , about  $\pm 10\%$ , about  $\pm 15\%$ , or about  $\pm 20\%$  of any such values.

[0353] FIGS. 2A-2D show example embodiments of a pattern of bulb shapes in which the bulbs 1010 in FIG. 2A and the bulbs 1110 in FIGS. 2B-2D have substantially the same shape. With reference to FIGS. 2B-2D, this substantially same shape pattern persists even when the bulbs 1110 have different sizes. In the embodiments illustrated in FIGS. 2A-2D, the bulbs 1010, 1110 are each spherical, but distal portions 100 including bulbs having other shapes that are substantially the same (e.g., oblong) are also possible.

[0354] FIG. 3A is a schematic side elevational view of another example embodiment of a distal portion 1200 of a vascular treatment device, for example the distal portion 100 of the device 10, 20, 30, or 40. The distal portion 1200 includes a plurality of woven bulbs 1210 and woven necks 1220. The distal portion 1200 includes a woven neck 65 at the distal end. A radiopaque marker band 25 is coupled to the distal end of the proximal portion 200, discussed in further detail herein. The bulbs 1210 are longitudinally spaced from each other by the woven necks 1220. In some embodiments, the bulbs 1210 and the necks 1220 are an integral textile structure in which the filaments that form the bulbs 1210 are the same as and longitudinally continuous with the filaments that form the necks 1220. The bulbs 1210 are generally oblong, although the proximal and distal ends of the bulbs 1210 may begin to form the necks 1220. The bulbs 1210 extend radially outward from the longitudinal axis, increasing in diameter from proximal to distal, reaching an intermediate point, staying at the intermediate diameter for some length, and then decreasing in diameter from proximal to distal. The necks 1220 are cylindrical or generally cylindrical along the longitudinal axis, although the ends of the necks 1220 may flare outwardly to begin to from the bulbs 1210. The bulbs 1210 in FIG. 3A have substantially uniform dimensions or diameters (e.g., within about  $\pm 5\%$ , about  $\pm 10\%$ , about  $\pm 15\%$ , or about 20% of each other) such that the distal portion 1200 may be considered non-tapered or cylindrical.

[0355] FIG. 3B is a schematic side elevational view of another example embodiment of a distal portion 1300 of a vascular treatment device, for example the distal portion 100 of the device 10, 20, 30, or 40. FIG. 3C is a perspective view of the distal portion 1300 of FIG. 3B. The distal portion 1300 includes a plurality of woven bulbs 1310 and woven necks 1320. The distal portion 1300 includes a woven neck 65 at the distal end. A radiopaque marker band 25 is coupled to the distal end of the proximal portion 200, discussed in further detail herein. The bulbs 1310 are longitudinally spaced from each other by the woven necks 1320. In some embodiments, the bulbs 1310 and the necks 1320 are an integral textile structure in which the filaments that form the bulbs 1310 are the same as and longitudinally continuous with the filaments that form the necks 1320. The bulbs 1310 are generally oblong, although the proximal and distal ends of the bulbs 1310 may begin to form the necks 1320. The bulbs 1310 extend radially outward from the longitudinal axis, increasing in diameter from proximal to distal, reaching an intermediate point, staying at the intermediate diameter for some length,

and then decreasing in diameter from proximal to distal. The necks 1320 are cylindrical or generally cylindrical along the longitudinal axis, although the ends of the necks 1320 may flare outwardly to begin to from the bulbs 1310.

[0356] The distal portion 1300 includes ten bulbs 1310: three bulbs 1312, three bulbs 1314, two bulbs 1316, and two bulbs 1318. The bulbs 1312 have a smaller diameter than the bulbs 1314, which have a smaller diameter than the bulbs 1316, which have a smaller diameter than the bulbs 1318. The bulbs 1312 have substantially uniform diameters, the bulbs 1314 have substantially uniform diameters, the bulbs 1316 have substantially uniform diameters, and the bulbs 1318 have substantially uniform diameters. Due to the differing diameters of the bulbs 1310, the distal portion 1300 may be considered tapered, for example inwardly tapered from proximal to distal or outwardly tapered from distal to proximal, or the distal portion 1300 may be considered stepped, for example inwardly stepped from proximal to distal or outwardly stepped from distal to proximal. Other and opposite configurations are also possible. For example, the bulbs 1310 may be inwardly tapered or stepped from distal to proximal or outwardly stepped from proximal to distal. For another example, the bulbs 1310 may have random (e.g., non-sequential) diameters along the length of the distal portion 1300, which may include sections that are substantially cylindrical and/or sections that are stepped or tapered distally and/or proximally.

[0357] In some embodiments, the outer diameters of the bulbs 1310 in the radially-expanded configuration are as follows: the three distal extra-small oblong bulbs 1312 have an outer diameter configured to be oversized to the extra-small vessel segments such as the M2 segments of the middle cerebral artery (e.g., about 1.5 mm to about 2.25 mm); the proximally-next three small oblong bulbs 1314 have an outer diameter configured to be oversized to the smaller vessel segments such as the distal M1 segment of the middle cerebral artery (e.g., about 2.25 mm to about 2.75); the proximally-next two medium oblong bulbs 1316 have an outer diameter configured to be oversized to the medium vessel segments such as the proximal M1 segment of the middle cerebral artery (e.g., about 2.75 mm to about 3.25 mm); and the proximal two large oblong bulbs 1318 have an outer diameter configured to be oversized to the large vessel segments such as the distal supra-clinoid segment of the internal carotid artery (e.g., about 3.25 mm to about 4 mm). A tapered configuration of the distal portion 1300 can allow for adequate and safe deployment of the distal portion 1300 across blood vessels with multiple and/or varying diameters (e.g., vasculature that progressively reduces in size). Although some example diameters are provided herein, some embodiments of the distal portion 1300 may include diameters of the bulbs 1312, 1314, 1316, 1318 in accordance with the values provided above and/or diameters that are without about  $\pm 5\%$ , about  $\pm 10\%$ , about  $\pm 15\%$ , or about  $\pm 20\%$  of any such values.

[0358] FIG. 4A is a schematic side elevational view of another example embodiment of a distal portion 1400 of a vascular treatment device, for example the distal portion 100 of the device 10, 20, 30, or 40. The distal portion 1400 includes a plurality of woven bulbs 1410 and woven necks 1420. The distal portion 1400 includes a woven neck 65 at the distal end. A radiopaque marker band 25 is coupled to the distal end of the proximal portion 200, discussed in further detail herein. The bulbs 1410 are longitudinally spaced from each other by the woven necks 1420. In some embodiments,

the bulbs **1410** and the necks **1420** are an integral textile structure in which the filaments that form the bulbs **1410** are the same as and longitudinally continuous with the filaments that form the necks **1420**. The necks **1420** are cylindrical or generally cylindrical along the longitudinal axis, although the ends of the necks **1420** may flare outwardly to begin to from the bulbs **1410**. The bulbs **1410** in FIG. 4A have substantially uniform diameters such that the distal portion **1400** may be considered non-tapered or cylindrical.

[0359] The distal portion **1400** includes ten bulbs **1410**: seven generally spherical bulbs **1412** and three generally oblong bulbs **1414**, in an interspersed pattern, from distal to proximal, of two bulbs **1412**, one bulb **1414**, two bulbs **1412**, one bulb **1414**, two bulbs **1412**, one bulb **1414**, and one bulb **1412**. Other interspersing patterns are also possible. For example, an interspersed pattern may include one bulb **1412**, one bulb **1414**, one bulb **1412**, one bulb **1414**, one bulb **1412**, one bulb **1414**, one bulb **1412**, and one bulb **1414**. For another example, interspersed pattern may include one bulb **1412**, two bulbs **1414**, one bulb **1412**, two bulbs **1414**, one bulb **1412**, two bulbs **1414**, and one bulb **1412**.

[0360] FIG. 4B is a schematic side elevational view of another example embodiment of a distal portion **1500** of a vascular treatment device, for example the distal portion **100** of the device **10**, **20**, **30**, or **40**. The bulbs **1510** are longitudinally spaced from each other by the woven necks **1520**. The distal portion **1500** includes a woven neck **65** at the distal end. A radiopaque marker band **25** is coupled to the distal end of the proximal portion **200**, discussed in further detail herein. In some embodiments, the bulbs **1510** and the necks **1520** are an integral textile structure in which the filaments that form the bulbs **1510** are the same as and longitudinally continuous with the filaments that form the necks **1520**. The necks **1520** are cylindrical or generally cylindrical along the longitudinal axis, although the ends of the necks **1520** may flare outwardly to begin to from the bulbs **1510**.

[0361] The distal portion **1500** includes ten bulbs **1510**: six generally spherical bulbs **1511** and four generally oblong bulbs **1531**. The generally spherical bulbs **1511** include two bulbs **1512**, two bulbs **1514**, one bulb **1516**, and one bulb **1518**. The bulbs **1512** have a smaller diameter than the bulbs **1514**, which have a smaller diameter than the bulb **1516**, which has a smaller diameter than the bulb **1518**. The bulbs **1512** have substantially uniform diameters and the bulbs **1514** have substantially uniform diameters. The generally oblong bulbs **1531** include one bulb **1532**, one bulb **1534**, one bulb **1536**, and one bulb **1538**. The bulb **1532** has a smaller diameter than the bulb **1534**, which has a smaller diameter than the bulb **1536**, which has a smaller diameter than the bulb **1538**. Due to the differing diameters of the bulbs **1510**, the distal portion **1500** may be considered tapered, for example inwardly tapered from proximal to distal or outwardly tapered from proximal to distal, or the distal portion **1500** may be considered stepped, for example inwardly stepped from proximal to distal or outwardly stepped from proximal to distal. Other and opposite configurations are also possible. For example, the bulbs **1510** may be inwardly tapered or stepped from distal to proximal or outwardly stepped from proximal to distal. For another example, the bulbs **1510** may have random (e.g., non-sequential) diameters along the length of the distal portion **1500**, which may include sections that are substantially cylindrical and/or sections that are stepped or tapered distally and/or proximally.

[0362] In some embodiments, the outer diameters of the bulbs **1510** in the radially-expanded configuration are as follows: the two distal extra-small spherical bulbs **1512** and the distal extra-small oblong bulb **1532** have an outer diameter configured to be oversized to the extra-small vessel segments such as the M2 segments of the middle cerebral artery (e.g., about 1.5 mm to about 2.25 mm); the proximally-next two small spherical bulbs **1514** and the small oblong bulb **1534** have an outer diameter configured to be oversized to the smaller vessel segments such as the distal M1 segment of the middle cerebral artery (e.g., about 2.25 mm to about 2.75 mm); the proximally-next medium spherical bulb **1516** and the medium oblong bulb **1536** have an outer diameter configured to be oversized to the medium vessel segments such as the proximal M1 segment of the middle cerebral artery (e.g., about 2.75 mm to about 3.25 mm); and the proximally-next large spherical bulb **1518** and the large oblong bulb **1538** have an outer diameter configured to be oversized to the large vessel segments such as the distal supra-clinoid segment of the internal carotid artery (e.g., about 3.25 mm to about 4 mm). A tapered configuration of the distal portion **1500** can allow for adequate and safe deployment of the distal portion **1500** across blood vessels with multiple and/or varying diameters (e.g., vasculature that progressively reduces in size). Although some example diameters are provided herein, some embodiments of the distal portion **1500** may include diameters of the bulbs **1512**, **1514**, **1516**, **1518**, **1532**, **1534**, **1536**, **1538** in accordance with the values provided above and/or diameters that are within about  $\pm 5\%$ , about  $\pm 10\%$ , about  $\pm 15\%$ , or about  $\pm 20\%$  of any such values.

[0363] The distal portion **1500** includes ten bulbs **1510**: six generally spherical bulbs **1511** and four generally oblong bulbs **1531**, in an interspersed pattern. Other interspersing patterns are also possible. For example, an interspersed pattern may include one bulb **1512**, one bulb **1532**, two bulbs **1514**, one bulb **1534**, two bulbs **1516**, one bulb **1536**, one bulb **1518**, and one bulb **1538**. For another example, interspersed pattern may include one bulb **1512**, two bulbs **1532**, two bulbs **1514**, one bulb **1534**, one bulb **1516**, one bulb **1536**, one bulb **1518**, and one bulb **1538**.

[0364] FIG. 4C is a schematic side elevational view of another example embodiment of a distal portion **2200** of a vascular treatment device, for example the distal portion **100** of the device **10**, **20**, **30**, or **40**. FIG. 4D is a schematic proximal end view of the distal portion **2200** shown in FIG. 4C. The distal portion **2200** includes a plurality of woven bulbs **2210** and woven necks **2220** including filaments **156**. The bulbs **2210** are longitudinally spaced from each other by the woven necks **2220**. In some embodiments, the bulbs **2210** and the necks **2220** are an integral textile structure in which the filaments that form the bulbs **2210** are the same as and longitudinally continuous with the filaments that form the necks **2220**. The bulbs **2210** are generally spherical, although the proximal and distal ends of the bulbs **2210** may begin to form the necks **2220**. The necks **2220** are aligned along a longitudinal axis **2230**. The bulbs **2210** are aligned along a longitudinal axis **2240**. The longitudinal axis **2240** may run through a center of the distal portion **2200**. The longitudinal axis **2230** is radially offset from the longitudinal axis **2240**. The necks **2220** are aligned with chords of the bulbs **2210**. The necks **2220** are cylindrical or generally cylindrical along the central or longitudinal axis, although the ends of the necks **2220** may flare outwardly to begin to from the bulbs **2210**. The bulbs **2210** in FIG. 4C have substantially uniform dimen-

sions or diameters (e.g., within about  $\pm 5\%$ , about  $\pm 10\%$ , about  $\pm 15\%$ , or about 20% of each other) such that the distal portion 2200 may be considered non-tapered or cylindrical.

[0365] FIG. 4E is a schematic side elevational view of yet another example embodiment of a distal portion 2400 of a vascular treatment device, for example the distal portion 100 of the device 10, 20, 30 or 40. FIG. 4F is a schematic proximal end view of the distal portion 2400 of FIG. 4E. The distal portion 2400 includes a plurality of woven bulbs 2410, 2415 and woven necks 2420. The bulbs 2410, 2415 are longitudinally spaced from each other by the woven necks 2420. In some embodiments, the bulbs 2410, 2415 and the necks 2420 are an integral textile structure in which the filaments 156 that form the bulbs 2410, 2415 are the same as and longitudinally continuous with the filaments 156 that form the necks 2420. The bulbs 2410, 2415 are generally spherical, although the proximal and distal ends of the bulbs 2410, 2415 may begin to form the necks 2420. The necks 2420 are aligned along a longitudinal axis 2430. The longitudinal axis 2430 may run through a center of the distal portion 2400. The longitudinal axis 2430 is aligned to the chords of bulbs 2410 and to the chords of the bulbs 2415. The chords through each of the bulbs 2410 are the same. The chords through each of the bulbs 2415 are the same. The chords through the bulbs 2410 are different from the chords through the bulbs 2415. The longitudinal position of the bulbs 2410, 2415 may alternate. The necks 2420 are between different chords of the bulbs 2410, 2415. The necks 2420 are cylindrical or generally cylindrical along the central or longitudinal axis, although the ends of the necks 2420 may flare outwardly to begin to from the bulbs 2410, 2415. The bulbs 2410 in FIG. 4E have substantially uniform dimensions or diameters (e.g., within about  $\pm 5\%$ , about  $\pm 10\%$ , about  $\pm 15\%$ , or about 20% of each other) such that the distal portion 2400 may be considered non-tapered or cylindrical.

[0366] FIG. 4G is a schematic side elevational view of yet another example embodiment of a distal portion 2500 of a vascular treatment device, for example the distal portion 100 of the device 10, 20, 30, or 40. FIG. 4H is a schematic proximal end view of the distal portion 2500 of FIG. 4G. The distal portion 2500 includes a plurality of woven bulbs 2510 along an elongate support structure 2520 (such as a neck, tube, spindle, spine, rod, backbone, etc.). The elongate support structure 2520 is aligned along a longitudinal axis 2530. The longitudinal axis 2530 may run through a center of the distal portion 2500. The bulbs 2510 are hemi-spherical or generally hemi-spherical along the longitudinal axis 2530, although the elongate support structure 2520 between the bulbs 2510 may flare outwardly to begin to from the bulbs 2510. In some embodiments, the bulbs 2510 are hemispherical or generally hemi-spherical and so they appear as bulges on the sides of a single elongate support structure 2520 rather than as bulbs separated by a plurality of necks. The bulbs 2510 have substantially uniform dimensions or diameters (e.g., within about  $\pm 5\%$ , about  $\pm 10\%$ , about  $\pm 15\%$ , or about 20% of each other) such that the distal portion 2500 may be considered non-tapered.

[0367] The distal portion 2500 includes bulbs 2510 that are phase-shifted. The bulbs 2510 are phase-shifted from each other by a phase-shift angle of about  $120^\circ$  relative to the longitudinal axis 2530 (for e.g., the bulbs 2516, 2512, 2519, 2515 are phase-shifted from the bulbs 2511, 2518, 2514 by a phase-shift angle 2560 of about  $120^\circ$ ; the bulbs 2511, 2518, 2514 are phase-shifted from the bulbs 2517, 2513, 2521 by a

phase-shift angle 2540 of about  $120^\circ$ ; and the bulbs 2517, 2513, 2521 are phase-shifted from the bulbs 2516, 2512, 2519, 2515 by a phase-shift angle 2550 of about  $120^\circ$ ). A phase-shifted configuration of the bulbs 2510 in the distal portion 2500 can allow for effective torsional rasping and mechanical thrombectomy of hard clots or organized thrombus adherent to the endothelium wall (inner walls of blood vessels). The term thrombus, as used herein, shall be given its ordinary meaning and shall include, but not be limited to, blood clots (e.g., attached to the blood vessel), emboli (e.g., floating blood clots), and other debris that may be removed from vessels. The terms thrombus, clot, and embolus may be used interchangeably depending on context. Although some example phase-shift angles are provided herein, some embodiments of the distal portion 2500 may include symmetric phase-shift angles that are uniform to each other with values that range between about  $15^\circ$  and about  $345^\circ$  (e.g., the phase-shift angles 2540, 2550, 2560 each being about  $120^\circ$ ). For another example, some embodiments of the distal portion 2500 may include asymmetric phase-shift angles that are varying to each other with values that range between about  $15^\circ$  and about  $345^\circ$  (e.g., the phase shift-angles 2540, 2550 both being about  $80^\circ$  and the phase-shift angle 2560 being about  $200^\circ$ ).

[0368] FIG. 4I is a schematic side elevational view of another example embodiment of a distal portion 1900 of a vascular treatment device, for example the distal portion 100 of the device 10, 20, 30, or 40. The distal portion 1900 includes a plurality of woven bulbs 1910 and woven necks 1920. The distal portion 1900 includes a woven neck 65 at the distal end. The necks 1920 are cylindrical or generally cylindrical along the longitudinal axis, although the ends of the necks 1920 may flare outwardly to begin to from the bulbs 1910.

[0369] The distal portion 1900 includes seven bulbs 1910: two bulbs 1911, two bulbs 1913, one bulb 1915, and two bulbs 1917. The bulbs 1911 have a smaller diameter than the bulbs 1913, which have a smaller diameter than the bulb 1915, which has a smaller diameter than the bulbs 1917. The bulbs 1911 have substantially uniform diameters, the bulbs 1913 have substantially uniform diameters, and the bulbs 1917 have substantially uniform diameters.

[0370] In some embodiments, the outer diameters of the bulbs 1910 in the radially-expanded configuration are as follows: the two distal extra-small spherical bulbs 1911 have an outer diameter configured to be oversized to the extra-small vessel segments such as the M2 segments of the middle cerebral artery (e.g., about 1.5 mm to about 2.25 mm); the proximally-next two small spherical bulbs 1913 have an outer diameter configured to be oversized to the smaller vessel segments such as the distal M1 segment of the middle cerebral artery (e.g., about 2.25 mm to about 2.75 mm); the proximally-next medium spherical bulb 1915 has an outer diameter configured to be oversized to the medium vessel segments such as the proximal M1 segment of the middle cerebral artery (e.g., about 2.75 mm to about 3.25 mm); and the proximally-next large spherical bulbs 1917 have an outer diameter configured to be oversized to the large vessel segments such as the distal supra-clinoid segment of the internal carotid artery (e.g., about 3.25 mm to about 4 mm). Due to the differing diameters of the bulbs 1910, the distal portion 1900 may be considered tapered, for example inwardly tapered from proximal to distal or outwardly tapered from distal to proximal, or the distal portion 1900 may be considered

stepped, for example inwardly stepped from proximal to distal or outwardly stepped from distal to proximal. Other and opposite configurations are also possible. For example, the bulbs **1910** may be inwardly tapered or stepped from distal to proximal or outwardly stepped from proximal to distal. For another example, the bulbs **1910** may have random (e.g., non-sequential) diameters along the length of the distal portion **1900**, which may include sections that are substantially cylindrical and/or sections that are stepped or tapered distally and/or proximally. A tapered configuration of the distal portion **1900** can provide adequate and safe deployment of the distal portion **1900** across blood vessels with multiple and/or varying diameters (e.g., vasculature that progressively reduces in size). Although some example diameters are provided herein, some embodiments of the distal portion **1900** may include diameters of the bulbs **1911**, **1913**, **1915**, **1917** in accordance with the values provided above and/or diameters that are within about  $\pm 5\%$ , about  $\pm 10\%$ , about  $\pm 15\%$ , or about  $\pm 20\%$  of any such values.

[0371] The necks **1920** include a first neck **1921** having a first neck diameter **1931** (also the distal neck **65**), a second neck **1922** having a second neck diameter **1932**, a third neck **1923** having a third neck diameter **1933**, a fourth neck **1924** having a fourth neck diameter **1934**, a fifth neck **1925** having a fifth neck diameter **1935**, a sixth neck **1926** having a sixth neck diameter **1936**, a seventh neck **1927** having a seventh neck diameter **1937**, and an eighth neck **1929** having an eighth neck diameter **1939** (also the proximal neck). The neck diameters **1930** including **1931**, **1932**, **1933**, **1934**, **1935**, **1936**, **1937**, **1939** are uniform or substantially uniform. The distal portion **1900** includes necks **1920** having varying lengths: four necks **1921**, **1922**, **1924**, **1927** having relatively short lengths, two necks **1926**, **1929** having relatively medium lengths, and two necks **1923**, **1925** having relatively long lengths in an interspersed pattern. Other interspersing patterns are also possible. For example, an interspersed pattern may include four necks **1921**, **1922**, **1924**, **1927** with relatively short lengths, two necks **1926**, **1929** with relatively medium lengths, and two necks **1923**, **1925** with relatively long lengths.

[0372] Necks **1921**, **1922**, **1923**, **1924**, **1925**, **1926**, **1927**, **1929** having varying lengths can provide controlled expansion of the bulbs **1910** adjacent to the necks **1920** during torsional rasping, aid in wall apposition of the bulbs **1910**, and/or inhibit or prevent distal emboli. Necks **1921**, **1922**, **1923**, **1924**, **1925**, **1926**, **1927**, **1929** having varying lengths may be deployed in such a manner that necks **1920** with longer lengths are deployed at the region of maximal clot burden, which can provide effective torsional rasping by entrapping soft clots or non-organized thrombus between the undulations of the bulbs **1910** on the varying lengths of the necks **1920**.

[0373] FIG. 4J is a schematic side elevational view of another example embodiment of a distal portion **2000** of a vascular treatment device, for example the distal portion **100** of the device **10**, **20**, **30**, or **40**. The distal portion **2000** includes a plurality of woven bulbs **2010** and woven necks **2020**. The distal portion **2000** includes a woven neck **65** at the distal end. The necks **2020** are cylindrical or generally cylindrical along the longitudinal axis, although the ends of the necks **2020** may flare outwardly to begin to from the bulbs **2010**.

[0374] The distal portion **2000** includes nine bulbs **2010**: three bulbs **2011**, two bulbs **2013**, two bulbs **2015**, and two

bulbs **2017**. The bulbs **2011** have a smaller diameter than the bulbs **2013**, which have a smaller diameter than the bulbs **2015**, which have smaller diameters than the bulbs **2017**. The bulbs **2011** have substantially uniform diameters, the bulbs **2013** have substantially uniform diameters, the bulbs **2015** have substantially uniform diameters, and the bulbs **2017** have substantially uniform diameters.

[0375] In some embodiments, the outer diameters of the bulbs **2010** in the radially-expanded configuration are as follows: the three distal extra-small spherical bulbs **2011** have an outer diameter configured to be oversized to the extra-small vessel segments such as the M2 segments of the middle cerebral artery (e.g., about 1.5 mm to about 2.25 mm); the proximally-next two small spherical bulbs **2013** have an outer diameter configured to be oversized to the smaller vessel segments such as the distal M1 segment of the middle cerebral artery (e.g., about 2.25 mm to about 2.75 mm); the proximally-next two medium spherical bulbs **2015** have an outer diameter configured to be oversized to the medium vessel segments such as the proximal M1 segment of the middle cerebral artery (e.g., about 2.75 mm to about 3.25 mm); and the proximally-next large spherical bulbs **2017** have an outer diameter configured to be oversized to the large vessel segments such as the distal supra-clinoid segment of the internal carotid artery (e.g., about 3.25 mm to about 4 mm). Due to the differing diameters of the bulbs **2010**, the distal portion **2000** may be considered tapered, for example inwardly tapered from proximal to distal or outwardly tapered from distal to proximal, or the distal portion **2000** may be considered stepped, for example inwardly stepped from proximal to distal or outwardly stepped from distal to proximal. Other and opposite configurations are also possible. For example, the bulbs **2010** may be inwardly tapered or stepped from distal to proximal or outwardly stepped from proximal to distal. For another example, the bulbs **2010** may have random (e.g., non-sequential) diameters along the length of the distal portion **2000**, which may include sections that are substantially cylindrical and/or sections that are stepped or tapered distally and/or proximally. A tapered configuration of the distal portion **2000** can provide adequate and safe deployment of the distal portion **2000** across blood vessels with multiple and/or varying diameters (e.g., vasculature that progressively reduces in size). Although some example diameters are provided herein, some embodiments of the distal portion **2000** may include diameters of the bulbs **2011**, **2013**, **2015**, **2017**, **2019** in accordance with the values provided above and/or diameters that are within about  $\pm 5\%$ , about  $\pm 10\%$ , about  $\pm 15\%$ , or about  $\pm 20\%$  of any such values.

[0376] The necks **2020** include a first neck **2021** having a first neck diameter **2041** (also the distal neck **65**), a second neck **2022** having a second neck diameter **2031**, a third neck **2023** having a third neck diameter **2032**, a fourth neck **2024** having a fourth neck diameter **2033**, a fifth neck **2025** having a fifth neck diameter **2034**, a sixth neck **2026** having a sixth neck diameter **2035**, a seventh neck **2027** having a seventh neck diameter **2036**, and an eighth neck **2028** having an eighth neck diameter **2037**, a ninth neck **2029** having a ninth neck diameter **2038**, a tenth neck **2040** having a tenth neck diameter **2039** (also the proximal neck). The distal portion **2000** includes varying neck diameters **2030**: seven necks **2021**, **2022**, **2023**, **2025**, **2026**, **2028**, **2040** having relatively narrow neck diameters **2041**, **2031**, **2032**, **2034**, **2035**, **2037**, **2039**, respectively, and three necks **2024**, **2027**, **2029** having relatively wide neck diameters **2033**, **2036**, **2038**, respec-

tively, in an interspersed pattern. Other interspersing patterns are also possible. For example, an interspersed pattern may include seven necks **2021**, **2022**, **2023**, **2025**, **2027**, **2029**, **2040** having relatively narrow neck diameters **2041**, **2031**, **2032**, **2034**, **2036**, **2038**, **2039**, respectively, and three necks **2024**, **2026**, **2028** having relatively wider neck diameters **2033**, **2035**, **2037**, respectively (e.g., relatively wider neck diameters between changing bulb diameters). For another example, an interspersed pattern may include five necks **2021**, **2024**, **2026**, **2028**, **2040** having relatively narrow neck diameters **2041**, **2033**, **2035**, **2037**, **2039**, respectively, and five necks **2022**, **2023**, **2025**, **2027**, **2029** having relatively wider neck diameters **2031**, **2032**, **2034**, **2036**, **2038**, respectively (e.g., relatively narrow neck diameters between changing bulb diameters).

[0377] Varying neck diameters **2031**, **2032**, **2033**, **2034**, **2035**, **2036**, **2037**, **2038**, **2039**, **2041** can allow for the outer diameters of the bulbs **2100** and/or the varying neck diameters **2030** to have adequate wall apposition across blood vessels with multiple and/or varying diameters (e.g., vasculature that progressively reduces in size), which can inhibit or prevent emboli from drifting into side branches of blood vessels during torsional rasping and/or mechanical thrombectomy. Varying neck diameters **2031**, **2032**, **2033**, **2034**, **2035**, **2036**, **2037**, **2038**, **2039**, **2041** can allow the distal portion **2000** to be deployed in such a way that the wider neck diameters are deployed at the region of bifurcations or higher blood vessel branches and/or at regions of blood vessel diameter transitions, which can allow the distal portion **2000** to serve as a filter to inhibit emboli from drifting into the branches of the blood vessels during torsional rasping and/or mechanical thrombectomy.

[0378] FIG. 4K is a schematic side elevational view of another example embodiment of a distal portion **2100** of a vascular treatment device, for example the distal portion **100** of the device **10**, **20**, **30**, or **40**. The distal portion **2100** includes a plurality of woven bulbs **2110** and woven necks **2120**. The distal portion includes a woven neck **65** at the distal end. The necks **2120** are cylindrical or generally cylindrical along the longitudinal axis, although the ends of the necks **2120** may flare outwardly to begin to from the bulbs **2110**.

[0379] The distal portion **2100** includes nine bulbs **2110**: three bulbs **2111**, two bulbs **2113**, two bulbs **2115**, and two bulbs **2117**. The bulbs **2111** have a smaller diameter than the bulbs **2113**, which have a smaller diameter than the bulbs **2115**, which have smaller diameters than the bulbs **2117**. The bulbs **2111** have substantially uniform diameters, the bulbs **2113** have substantially uniform diameters, the bulbs **2115** have substantially uniform diameters, and the bulbs **2117** have substantially uniform diameters.

[0380] In some embodiments, the outer diameters of the bulbs **2110** in the radially-expanded configuration are as follows: the three distal extra-small spherical bulbs **2111** have an outer diameter configured to be oversized to the extra-small vessel segments such as the M2 segments of the middle cerebral artery (e.g., about 1.5 mm to about 2.25 mm); the proximally-next two small spherical bulbs **2113** have an outer diameter configured to be oversized to the smaller vessel segments such as the distal M1 segment of the middle cerebral artery (e.g., about 2.25 mm to about 2.75 mm); the proximally-next medium spherical bulbs **2115** have an outer diameter configured to be oversized to the medium vessel segments such as the proximal M1 segment of the middle cerebral artery (e.g., about 2.75 mm to about 3.25 mm); and

the proximally-next large spherical bulbs **2117** have an outer diameter configured to be oversized to the large vessel segments such as the distal supra-clinoid segment of the internal carotid artery (e.g., about 3.25 mm to about 4 mm). Due to the differing diameters of the bulbs **2110**, the distal portion **2100** may be considered tapered, for example inwardly tapered from proximal to distal or outwardly tapered from distal to proximal, or the distal portion **2100** may be considered stepped, for example inwardly stepped from proximal to distal or outwardly stepped from distal to proximal. Other and opposite configurations are also possible. For example, the bulbs **2110** may be inwardly tapered or stepped from distal to proximal or outwardly stepped from proximal to distal. For another example, the bulbs **2110** may have random (e.g., non-sequential) diameters along the length of the distal portion **2100**, which may include sections that are substantially cylindrical and/or sections that are stepped or tapered distally and/or proximally. A tapered configuration of the distal portion **2100** can provide adequate and safe deployment of the distal portion **2100** across blood vessels with multiple and/or varying diameters (e.g., vasculature that progressively reduces in size). Although some example diameters are provided herein, some embodiments of the distal portion **2100** may include diameters of the bulbs **2111**, **2113**, **2115**, **2117** in accordance with the values provided above and/or diameters that are within about  $\pm 5\%$ , about  $\pm 10\%$ , about  $\pm 15\%$ , or about  $\pm 20\%$  of any such values.

[0381] The necks **2120** include a first neck **2121** having a first neck diameter **2131** (also the distal neck **65**), a second neck **2122** having a second neck diameter **2132**, a third neck **2123** having a third neck diameter **2133**, a fourth neck **2124** having a fourth neck diameter **2134**, a fifth neck **2125** having a fifth neck diameter **2135**, a sixth neck **2126** having a sixth neck diameter **2136**, a seventh neck **2127** having a seventh neck diameter **2137**, an eighth neck **2128** having an eighth neck diameter **2138**, a ninth neck **2129** having a ninth neck diameter **2129**, a tenth neck **2145** having a tenth neck diameter **2141** (also the proximal neck). The necks **2120** have varying neck diameters **2130** and varying lengths.

[0382] The distal portion **2100** includes varying neck diameters **2130**: seven necks **2121**, **2122**, **2123**, **2125**, **2126**, **2128**, **2145** having relatively narrow neck diameters **2131**, **2132**, **2133**, **2135**, **2136**, **2138**, **2141**, respectively, and three necks **2124**, **2127**, **2129** having relatively wide neck diameters **2134**, **2137**, **2139**, respectively, in an interspersed pattern. Other interspersing patterns are also possible. For example, an interspersed pattern may include seven necks **2121**, **2122**, **2123**, **2125**, **2127**, **2129**, **2145** having relatively narrow neck diameters **2131**, **2132**, **2133**, **2135**, **2137**, **2139**, **2141**, respectively, and three necks **2124**, **2126**, **2128** having relatively wider neck diameters **2134**, **2136**, **2138**, respectively (e.g., relatively wider neck diameters between changing bulb diameters). For another example, an interspersed pattern may include five necks **2121**, **2124**, **2126**, **2128**, **2145** having relatively narrow neck diameters **2131**, **2134**, **2136**, **2138**, **2141**, respectively, and five necks **2122**, **2123**, **2125**, **2127**, **2129** having relatively wider neck diameters **2132**, **2133**, **2135**, **2137**, **2139**, respectively (e.g., relatively narrow neck diameters between changing bulb diameters).

[0383] The distal portion **2100** includes necks **2120** having varying lengths: eight necks **2121**, **2122**, **2123**, **2124**, **2126**, **2127**, **2129**, **2145** having relatively short lengths, one neck **2128** having a relatively medium length, and one neck **2125** having a relatively long length in an interspersed pattern.

Other interspersing patterns are also possible. For example, an interspersed pattern may include four necks **2121**, **2122**, **2123**, **2124** having relatively short lengths, four necks **2126**, **2127**, **2129**, **2145** having relatively medium lengths, and two necks **2125**, **2128** having relatively large lengths.

[0384] Varying neck diameters **2131**, **2132**, **2133**, **2134**, **2135**, **2136**, **2137**, **2138**, **2139**, **2141** can allow for the outer diameters of the bulbs **2110** and/or the varying neck diameters **2130** to have adequate wall apposition across blood vessels with multiple and/or varying diameters (e.g., vasculature that progressively reduces in size), which can inhibit or prevent emboli from drifting into side branches of blood vessels during torsional rasping and/or mechanical thrombectomy. Varying neck diameters **2130** including **2131**, **2132**, **2133**, **2134**, **2135**, **2136**, **2137**, **2138**, **2139**, **2141** can allow the distal portion **2100** to be deployed in such a way that the wider neck diameters are deployed at the region of bifurcations or higher blood vessel branches and/or at regions of blood vessel diameter transitions, which can allow the distal portion **2100** to serve as a filter to inhibit emboli from drifting into the branches of the blood vessels during torsional rasping and/or mechanical thrombectomy. Necks **2121**, **2122**, **2123**, **2124**, **2125**, **2126**, **2127**, **2128**, **2129**, **2145** having varying lengths can provide controlled expansion of the bulbs **2110** adjacent to the necks **2120** during torsional rasping, aid in wall apposition of the bulbs **2110**, and/or inhibit or prevent distal emboli. Necks **2121**, **2122**, **2123**, **2124**, **2125**, **2126**, **2127**, **2128**, **2129**, **2145** having varying lengths may be deployed in such a manner that necks **2120** with longer lengths are deployed at the region of maximal clot burden, which can provide effective torsional rasping by entrapping soft clots or non-organized thrombus between the undulations of the bulbs **2110** on the varying lengths of the necks **2120**. Necks **2121**, **2122**, **2123**, **2124**, **2125**, **2126**, **2127**, **2128**, **2129**, **2145** with varying lengths and/or diameters **2131**, **2132**, **2133**, **2134**, **2135**, **2136**, **2137**, **2138**, **2139**, **2141** may provide for combinations of some or all of these advantages.

[0385] As illustrated, for example in FIGS. 2A-4K, and described herein, the distal portion **100** of the device **10**, **20**, **30**, or **40** may include a wide variety of different bulb parameters such as bulb quantity, shape, size, spacing, phase-shifting with regards to the longitudinal axis or to a chord of the axis, filament parameters (e.g., material, material ratio, thickness, shape, etc.), different neck parameters (e.g., neck diameter, neck length, etc.), braid parameters (e.g., pattern, angle, density, pore size, etc.), alignment to the longitudinal axis or to a chord of the axis, combinations thereof, and the like.

[0386] Each of the distal portions **1000**, **1100** illustrated in FIGS. 2A and 2B includes ten bulbs **1010**, **1110**. Other numbers of bulbs **1010**, **1110** are also possible. For example, in some embodiments, the distal portion includes between one and nine bulbs, between 11 and 30 bulbs, or more than 30 bulbs. In some embodiments, the distal portion includes 2, 3, 4, 5, 6, 7, 8, 9, 10, 11, 12, 13, 14, 15, 16, 17, 18, 19, or 20 bulbs. In some implementations, for example in which the device is configured to be used in peripheral vessels (e.g., in the leg), where clots can be up to 20 cm or even 40 cm, 11 to 30 or more, or 40 to 60, bulbs may be used. In some embodiments, 1 bulb is used for about every 0.2 cm to 5 cm (e.g., about every 0.5 cm to 2 cm).

[0387] The term bulb, as used herein, shall be given its ordinary meaning and shall include, but not be limited to, protruding or bulging portions that may be rounded (e.g., rounded balls, spheres, cylinders, or beads) or non-rounded,

which are typically, but not necessarily, provided along (e.g., separately or integrated with) a support structure. A bulb may have a consistent cross-section or may have two or more different cross-sections. A bulb may have one, two, or more than two open ends or lumens therethrough. Bulb shapes may include, for example, e.g., with respect to a top view, side view, and/or cross-section, at least one of sphere, oblong, egg, oval, ellipse, cylinder, spiral, twisted, helical, triangle, rectangle, parallelogram, rhombus, square, diamond, pentagon, hexagon, heptagon, octagon, nonagon, decagon, quatrefoil, trapezoid, trapezium, other polygons, oblate spheroids (e.g., flattened spheroids), prolate spheroids (e.g., elongated spheroids), curvilinear or bulged versions of these and other shapes, combinations thereof (e.g., a distal section of bulb having a different shape than a proximal section of a bulb), and the like. Different shapes of bulbs may be used in a distal portion **100**. For example, as illustrated in FIGS. 4A and 4B, spherical bulbs and oblong bulbs may be used in the same distal portion **100**. In some embodiments, different shapes of bulbs are alternated. In some embodiments, the distal portion **100** includes a series of various shapes of bulbs (e.g., including two or more bulbs each having different shapes), and each series is repeated two, three, four, five, six, seven, or more times. In some embodiments, the distal portion **100** includes bulbs having a first shape at the ends and bulbs having a second different shape between the end bulbs. In some embodiments, the distal portion **100** includes bulbs having a first shape in a distal section and bulbs having a second different shape in a proximal section.

[0388] In some embodiments in which a bulb comprises an egg, oval or elliptical shape, a tapered portion of the bulb facing the distal end of the distal portion **100** can aid navigation to increasingly small vessels, for example at the transition point to a smaller vessel. For example, the tapered end of can help the distal portion **100** from internal carotid artery (ICA) to M1 or from M1 to M2 segments of the brain.

[0389] In some embodiments, at least some of the bulbs have a size (with respect to the outer diameter in an expanded configuration) of about 1 mm to about 80 mm (e.g., about 2 mm to about 12 mm). Bulbs in range of about 1 mm to about 6 mm, about 3 mm to about 4.5 mm, about 0.5 mm to about 3 mm (e.g., about 3 mm), 0.75 mm to about 3 mm (e.g., about 3 mm), about 3.1 mm to about 3.9 mm (e.g., about 3.5 mm), about 4 mm to about 4.4 mm (e.g., 4 mm), and about 4.5 mm to about 7.5 mm (e.g., about 4.5 mm) may be particular beneficial for smaller clots and/or vessels (e.g., in the brain). Bulbs in range of about 4 mm to about 10 mm and about 5 mm to about 40 mm may be particular beneficial for larger clots and/or vessels (e.g., in the leg). In some embodiments, all of the bulbs have a size (with respect to the outer diameter in an expanded configuration) greater than about 0.75 mm, greater than about 1 mm, greater than about 1.5 mm, greater than about 2 mm, greater than about 2.5 mm, or greater than about 2.75 mm. Large sizes may be particularly beneficial in some embodiments because they effectively engage or appose vessel walls, are simpler to manufacture, etc.

[0390] The bulb sizes described herein may be reduced by about 1.3 times to about 10 times (e.g., about 1.3 to about 2.5 times, about 2.5 to about 4 times, about 4 to about 7 times, about 7 to about 10 times, and overlapping ranges therein) in the collapsed configuration. In some embodiments, the collapsed configuration of the bulbs is about 50% to about 80% of the inner diameter of the delivery catheter (e.g., microcatheter). For example, in embodiments in which a microcatheter

has an inner diameter of about 0.0125 inches (approx. 0.32 mm), the bulbs in the collapsed state can have a diameter between about 0.006 inches (approx. 0.16 mm) and about 0.01 inches (approx. 0.25 mm). In some embodiments, for example for use in small vessels, the bulbs may have a size in the collapsed state of about 0.1 mm and about 0.9 mm (e.g., about 0.25 mm to about 0.5 mm). In some embodiments, for example for use in small vessels, the bulbs may have a size in the collapsed state of about 0.5 mm and about 5 mm.

[0391] In some embodiments, the dimensions of the bulbs vary based on the shape of the bulb. For example, the diameter may vary if the shape is a sphere. For another example, the diameter and/or length may vary if the shape is oblong. For yet another example, the length of a side and/or the angle of a vertex of a may vary if the shape of is a polygon (e.g., triangle).

[0392] The diameter or width of the distal portion **100** varies along the length of the distal portion **100**. Examples of diameters or widths of bulbs are described above. In some embodiments, the diameter or width of the necks between, proximal to, and/or distal to bulbs is in the range of about 0.15 mm to about 0.75 mm, about 0.35 mm to about 0.65 mm (e.g., about 0.38 mm), or about 0.4 mm to about 0.45 mm in an expanded configuration and in the range of about 0.1 mm to about 0.5 mm, about 0.1 mm to about 0.34 mm, about 0.27 mm to about 0.37 mm, or about 0.25 mm to about 0.33 mm (e.g., about 0.32 mm) in the collapsed configuration. In some embodiments, the diameter or width of the distal portion **100** is in the range of about 0.1 mm to about 0.34 mm (e.g., about 0.25 mm to about 0.33 mm) in the collapsed configuration, for example small enough to fit in the smallest currently commercially available microcatheter, which has an inner diameter of 0.017 inches (approx. 0.43 mm). In some implementations, for example in which the device is configured to be used in larger vessels, the diameter or width of the distal portion **100** is in the range of about 1 mm to about 40 mm (e.g., about 5 mm to about 20 mm) in the expanded configuration and the in the range of about 0.5 mm to about 10 mm (e.g., about 1 mm to about 2 mm) in the collapsed configuration.

[0393] The diameter or dimension of the necks may be the same or different. For example, the diameters of the necks may vary across the longitudinal length of the distal portion **100**. In some embodiments, the diameter of the neck at least partially depends on the size of one or both adjacent bulbs. For example, referring again to FIG. 2B, the diameter of the necks **1120** between the bulbs **1118** may be larger than the diameter of the necks **1120** between the bulbs **1116**, which may be larger than the diameter of the necks **1120** between the bulbs **1114**, which may be larger than the diameter of the necks **1120** between the bulbs **1112**. In some embodiments, varying the diameter or dimension of the necks with variance in the diameter or dimension of the bulbs can help to vary or maintain an undulation pattern, which can help to trap thrombus and/or inhibit or prevent distal emboli with enhanced wall apposition by the bulbs **1110** and the necks **1120**.

[0394] In some embodiments, starting at the distal end of the distal portion **100**, each consecutively proximal bulb is larger than the other. In some embodiments, two or more bulb sizes may be in an alternating pattern. As an example, a series of three bulb sizes may be alternated seven times for a total of twenty-one bulbs. In some embodiments, three or more bulb sizes are in a series, and each series is repeated two, three, four, five, six, seven, or more times. In some embodiments,

larger bulbs may be at the ends of the distal portion **100**, while smaller bulbs are in the middle of the distal portion **100**. In some embodiments, smaller bulbs may be at the ends of the distal portion **100**, while larger bulbs are in the middle of the distal portion **100**. In some embodiments, the distal portion **100** comprises bulbs of varying dimensions without specificity to a longitudinal position.

[0395] The positioning or spacing of the bulbs may be beneficial for certain vessel sizes and/or clot locations, material, and/or sizes. Bulbs may be touching (e.g., contiguous) or non-touching. The distal portion **100** may include bulbs that are both touching and non-touching. In some embodiments, the distal portion **100** includes bulbs that are all non-touching and/or are spaced apart by one or more necks. These necks may be of the same or different material than the bulbs. The necks may also be shaped differently than the bulbs. The necks may comprise, be embedded with, or coated by markers or other visualization aids (such as radiopaque portions).

[0396] The bulbs may be separated by distances of about 0.1 mm to about 50 mm, including, but not limited to, about 0.5 mm to about 1 mm, about 1 mm to about 2 mm, about 2 mm to about 3 mm, about 3 mm to about 4 mm, about 4 mm to about 5 mm, about 5 mm to about 8 mm, about 8 mm to about 10 mm, about 10 mm to about 12 mm, about 12 mm to about 15 mm, about 15 mm to about 25 mm, about 25 mm to about 35 mm, and about 35 mm to about 50 mm apart, including overlapping ranges thereof. The spaces between the bulbs in the distal portion **100** may be constant, or spacing between two or more (or all) of the bulbs may be different. In some embodiments, some bulbs are spaced the same distance from one another, while other bulbs have different spacing. In some embodiments, the length of the necks can at least partially depend on the length of at least one adjacent bulb. For example, the length of a neck may be between about 0.25 to about 2 times the length of a bulb proximal thereto, a bulb distal thereto, or an average length of the bulbs proximal and distal thereto. The necks can be more than an inert link between two bulbs. For example, when a distal portion **100** is torsionally rasped, longer necks may be squeezed tighter as they are rotated, allowing the bulbs ahead and behind to bulge even further. When the necks are the same length and a distal portion **100** is torsionally rasped, each of the necks will be squeezed moderately, resulting in moderate radial force out of the preceding and following bulbs.

[0397] In some embodiments, lengths of the necks may be at least partially based on the size and quantity of the bulbs the desired length of the distal portion **100**, and/or the desired length of a distal neck **65**, described further herein. For example, if the desired length of the distal portion **100** is about 60.5 cm, if three spherical bulbs having a diameter of about 3 mm, three spherical bulbs having a diameter of about 3.5 mm, two spherical bulbs having a diameter of about 4 mm, and two spherical bulbs having a diameter of about 4.5 mm are desired, and approximately equal spacing with a distal neck **65** having a length of about 4 mm, the necks may have a length of about 2 mm including a neck proximal to the proximal-most bulb.

[0398] Neck shapes may include, for example, e.g., with respect to a cross-section, at least one of a circle, oblong, egg, oval, ellipse, triangle, rectangle, parallelogram, rhombus, square, diamond, pentagon, hexagon, heptagon, octagon, nonagon, decagon, quatrefoil, trapezoid, trapezium, other polygons, curvilinear or bulged versions of these and other shapes, combinations thereof (e.g., a distal section of neck

having a different shape than a proximal section of a neck, and the like. Different shapes of necks may be used in a distal portion **100**. In some embodiments, the distal shape of the neck at least partially depends on the shape of at least one adjacent bulb.

**[0399]** The distal portion **100** may be braided, knitted, or woven with two or more strands (e.g., about 6 strands to about 144 strands, about 12 strands to about 120 strands, about 12 strands to about 96 strands, about 12 strands to about 72 strands, about 48 strands) in some embodiments. Strands may include filaments, wires, ribbons, etc. having a circular cross-section, an arcuate non-circular cross-section (e.g., oval, ellipsoid, etc.), a rectangular cross-section (e.g., square), a trapezoidal cross-section, combinations thereof, and the like. In some embodiments, the number of strands of a distal portion **100** is at least partially based on the desired expanded configuration diameter of the distal portion **100**. For example, in some embodiments, 32 strands are used for a distal portion **100** expanded configuration diameter ranging from 2.5 mm and smaller, 48 strands are used for a distal portion **100** expanded configuration diameter ranging from about 2.5 mm to about 4.5 mm, 64 strands are used for a distal portion **100** expanded configuration diameter ranging from about 4.5 mm to about 6.0 mm, 72 strands are used for a distal portion **100** expanded configuration diameter ranging from 6.0 mm and greater, etc. In some embodiments, the strands have a diameter between about 0.0005 inches (approx. 0.013 mm) and about 0.04 inches (approx. 1 mm) (e.g., between about 0.0005 inches (approx. 0.013 mm) and about 0.0015 inches (approx. 0.038 mm), between about 0.0008 inches (approx. 0.02 mm) and about 0.012 inches (approx. 0.3 mm), between about 0.0008 inches (approx. 0.02 mm) and about 0.002 inches (approx. 0.05 mm), e.g., about 0.001 inches (approx. 0.025 mm), about 0.00125 inches (approx. 0.032 mm)). As the diameter of the vessel(s) to be treated increases, the diameter of the distal portion **100** increases, and at least one of the number of filaments, filament density, filament diameter, etc. may also increase, for example to provide the same density, picks (or pixels) per inch (PPI), etc. of the distal portion **100** or a portion thereof. In some embodiments, the necks have a uniform PPI.

**[0400]** The thickness or diameter of filaments comprising shape memory material may influence mechanical properties such as hoop strength, for example thicker filaments imparting more hoop strength. The thickness or diameter of filaments comprising radiopaque material may influence the visibility under x-ray and/or fluoroscopy, for example thicker filaments being easier to visualize. In some embodiments, the distal portion **100** comprises a shape memory filament having a first diameter or thickness and a radiopaque filament having a second diameter or thickness different than the first diameter or thickness. Different thicknesses or diameters can, for example allow adjustment to filament size based at least partially on the intended use of that filament. For example, if large hoop strength is not desired but high visibility is desired, relatively lower diameter shape memory filaments and relatively larger radiopaque filaments may be used. Other combinations are also possible. For example, in some embodiments, the distal portion **100** comprises a first shape memory filament having a first diameter or thickness and a second shape memory filament having a second diameter or thickness different than the first diameter or thickness. For another example, in some embodiments, the distal portion **100** comprises a first radiopaque filament having a first diameter or

thickness and a second radiopaque filament having a second diameter or thickness different than the first diameter or thickness.

**[0401]** In some embodiments, the distal portion **100** is configured to allow the user of a device **10**, **20**, **30**, **40** to crowd, compress, or bunch parts of the distal portion **100** such that some parts of the distal portion **100** have a higher density in some sections than in other sections, which may be useful, for example, for removing stubborn clots inhibiting or preventing inadvertent emboli, and/or decreasing flow into an aneurysm or an arterio-venous fistula to aid thrombosis.

**[0402]** The distal portion **100** may have a length in the range of about 0.5 cm to about 20 cm (e.g., about 1 cm to about 20 cm, about 5 cm to about 10 cm, about 4 cm to about 8 cm, etc.). In some implementations, for example in which the device is configured to be used in larger vessels (e.g., outside the brain), the distal portion **100** may have a length greater than about 20 cm (e.g., about 20 cm to about 50 cm). The length of the distal portion **100** may be characterized by the length of the distal portion **100** configured to appose the sidewalls of a vessel. For example, the length of the distal portion **100** may be characterized by approximately the center of the proximal-most bulb to the center of the distal-most bulb. In some embodiments, the usable length of the distal portion is between about 5 mm and about 60 mm (e.g., about 55.25 mm, which would be slightly oversized for treatment of any clot up to about 55 mm in length). As described further herein, the entire length of the distal portion **100** need not be used in every procedure.

**[0403]** The distal portion **100** may have a wall thickness, in some embodiments, ranging from about 0.01 mm to about 4 mm, about 0.02 mm to about 1 mm, or about 0.02 mm to about 0.05 mm (e.g., about 0.025 mm). The wall thickness may be between the thickness or diameter of one strand and the thickness or diameter of two strands (e.g., at a strand crossing point), in accordance with strand dimensions described herein. In some embodiments, the distal neck **65** or the distal end of the distal portion **100** may have the same or a different wall thickness than sections of the distal portion **100** proximal thereto. For example, the distal neck **65** or the distal end of the distal portion **100** may have a wall thickness between about 0.01 mm and about 4 mm, between about 0.02 mm and about 1 mm, or between about 0.02 mm and about 0.05 mm (e.g., about 0.025 mm). In some embodiments, the distal neck **65** or the distal end of the distal portion **100** may have the same or a different number of filaments than sections of the distal portion **100** proximal thereto. For example, the distal neck **65** or the distal end of the distal portion **100** may have a number of filaments between about 6 and about 144, between about 12 and about 120, between about 12 and about 96, or between about 12 and about 72 (e.g., about 48). In some embodiments, the distal neck **65** or the distal end of the distal portion **100** may have the same or a different ratio between diameter or dimension in an expanded state to diameter or dimension in a collapsed state. For example, the distal neck **65** or the distal end of the distal portion **100** may have a ratio between about 1:1 (e.g., collapsed state and expanded state are the same) and about 10:1 (e.g., about 1.2:1).

**[0404]** At least some of the strands of the distal portion **100** may comprise a shape memory alloy (e.g., nickel titanium or cobalt chromium). In some embodiments, about 50% to about 95% (e.g., about 75%) of the strands of the distal portion **100** comprise a shape memory alloy (e.g., nickel titanium, cobalt chromium, etc.) and about 5 to about 50% (e.g., 25%) of the



strands of the distal portion **100** comprise a radiopaque material (e.g., platinum iridium, platinum tungsten, etc.). In some embodiments, the distal portion **100** comprises between about 1 strand and about 144 strands, between about 1 strand and about 120 strands, between about 1 strand and about 60 strands, between about 2 strands and about 48 strands (e.g., about 36 strands), etc. comprising a shape memory alloy (e.g., nickel titanium, cobalt chromium, etc.). In some embodiments, the distal portion **100** comprises between about 1 strand and about 60 strands, between about 1 strand and about 48 strands, between about 2 strands and about 24 strands (e.g., about 12 strands), etc. comprising a radiopaque material (e.g., platinum iridium, platinum tungsten, etc.). The shape memory filaments may help with heat treating to an expanded distal portion **100** shape, and the radiopaque filaments may aid in visualizing the device under x-ray and/or fluoroscopy during a procedure using the distal portion **100**. The radiopaque strands can be spaced or clustered to increase visibility under x-ray and/or fluoroscopy. For example, a thick-band pattern may be used, which can include a plurality of radiopaque strands (e.g., 2 to 12 radiopaque strands) that are circumferentially adjacent.

[0405] In some embodiments, the distal portion **100** (e.g., the elongate support structure and/or the bulbs) comprises filaments including materials that are biocompatible or surface-treated to produce biocompatibility. Suitable materials may include, for example, platinum, titanium, nickel, chromium, cobalt, tantalum, tungsten, iron, manganese, molybdenum, and alloys thereof including nickel titanium (e.g., nitinol), nickel titanium niobium, chromium cobalt, copper aluminum nickel, iron manganese silicon, silver cadmium, gold cadmium, copper tin, copper zinc, copper zinc silicon, copper zinc aluminum, copper zinc tin, iron platinum, manganese copper, platinum alloys, cobalt nickel aluminum, cobalt nickel gallium, nickel iron gallium, titanium palladium, nickel manganese gallium, stainless steel, shape memory alloys, etc. Suitable materials may also include polymers such as polylactic acid (PLA), polyglycolic acid (PGA), poly lactic co-glycolic acid (PLGA), polycaprolactone (PCL), polyorthoesters, polyanhydrides, and copolymers thereof. Suitable materials may also include alloys (e.g., nitinol, chromium cobalt, platinum tungsten, etc.) and combinations of materials (e.g., filaments with a radiopaque core or cladding in combination with a cladding or core, respectively, of a different material, a plurality of filaments including different materials, etc.). In some embodiments, the distal portion **100** comprises nitinol and platinum tungsten.

[0406] In some embodiments, prior to braiding, the shape memory filaments are cold worked (e.g., without heat treatment). In some embodiments, prior to braiding, the shape memory filaments are straight annealed (e.g., undergone heat treatment and straightened as a wire).

[0407] In some embodiments, the braid pattern of the distal portion **100** is one-over-one-under-one, one-over-one-under-two, one-over-two-under-two, two-over-one-under-one, two-over-one-under-two, three-over-one-under-one, three-over-one-under-two, three-over-one-under-three, three-over-two-under-one, three-over-two-under-two, three-over-three-under-one, three-over-three-under-two, three-over-three-under-three, two-over-two-under-one, two-over-two-under-two, etc. In some embodiments, a braid pattern of one-over-one-under-one can result in the highest radial force and smallest pore size. Other patterns may result in a relatively higher pore size and/or relatively lower radial force. The braid

pattern may be constant along the entire length of the distal portion **100**, or may vary, for example along the longitudinal axis of the distal portion **100**. For example, the braid pattern may vary between the necks and bulbs, from proximal to distal, etc. The braid pattern or filament crossover pattern, which is generally due to rotation and spinning of the braiding device or carrier braider during braiding, is different than a radiopaque banding pattern, which is generally due to the arrangement of the filaments on the spools or carriers prior to braiding and/or the rotation and spinning of the braiding device or carrier braider.

[0408] The braid angle is the angle between the filaments and an axis perpendicular to the longitudinal or production axis of the distal portion **100**, which can range from about 0° to about 180°. FIG. 4L is a schematic side elevational view of still another example embodiment of a distal portion **4800** of a vascular treatment device, for example the distal portion **100** of the device **10**, **20**, **30** or **40**. The distal portion **4800** comprises a plurality of filaments including left-leaning filaments **4815** and right-leaning filaments **4825** that are woven over a longitudinal or production axis **4840**. FIG. 4M is a schematic side elevational view of still another example embodiment of a distal portion **4900** of a vascular treatment device, for example the distal portion **100** of the device **10**, **20**, **30** or **40**. The distal portion **4900** comprises a plurality of filaments including left-leaning filaments **4915** and right-leaning filaments **4925** that are woven over a longitudinal or production axis **4840**. In each of FIGS. 4L and 4M, an axis that is perpendicular to the longitudinal or production axis **4840** is the braid axis **4850**. The relative speed of rotation of the horn gear in the horizontal plane, which is part of the braider device or carrier braider as described herein, and the motion of the puller in the vertical direction **164** can at least partially determine the braid angle. The left-leaning filaments **4815**, **4915** have a braid angle ( $BA_L$ ) **4810**, **4910** and the right-leaning filaments **4825**, **4925** have a braid angle ( $BA_R$ ) **4820**, **4920**. The braid angle **4810**, **4910** of the left-leaning filaments **4815**, **4925** is the obtuse angle **4810**, **4910** formed by each left-leaning filament **4815**, **4915** and the braid axis **4850**. The braid angle **4820**, **4920** of the right-leaning filaments **4825**, **4925** is the obtuse angle **4820**, **4920** formed by each right-leaning filament **4825**, **4925** and the braid axis **4850**. In the embodiment illustrated in FIG. 4L, the braid angle **4810** is about 120° and the braid angle **4820** is about 120°. In the embodiment illustrated in FIG. 4M, the braid angle **4910** is about 155° and the braid angle **4920** is about 155°.

[0409] In some embodiments in which the filaments **4815**, **4825**, **4915**, **4925** extend from spools mounted on the spindles of a braider device or carrier braider that are symmetrically arranged, the  $BA_L=BA_R$ , which can result in symmetric pore sizes for the distal portion **100**. In some embodiments in which the filaments **4815**, **4825**, **4915**, **4925** extend from spools mounted on the spindles of a braider device or carrier braider that are asymmetrically arranged, the  $BA_L$  and  $BA_R$  can be different, which can result in asymmetric pore sizes for the distal portion **100**.

[0410] The interlacing angle is the angle between the right-leaning filaments **4825**, **4925** and the left-leaning filaments **4815**, **4915** of the distal portion **100**, which can range from about 0° to about 180° (e.g., about 0° to about 90°). In the embodiment illustrated in FIG. 4L, the interlacing angle **4830** is about 60°. In the embodiment illustrated in FIG. 4M, the interlacing angle **4930** is about 130°.

**[0411]** In some embodiments, braid angle may be influenced by a ratio between the speed of rotation  $S_h$  of the circular horn gear or yarn wheel and the speed of motion  $S_v$  in the vertical direction of the puller ( $S_h/S_v$ ). For example, if the speed of rotation  $S_h$  is slower than the speed of motion  $S_v$  (e.g., when the horn gear ratio  $S_h/S_v$  is less than 1.0), a relatively low braid angle can be obtained, for example as illustrated in FIG. 4M. For another example, if the speed of rotation  $S_h$  is faster than the speed of motion  $S_v$  (e.g., when the horn gear ratio  $S_h/S_v$  is greater than 1.0), a relatively high braid angle can be obtained, for example as illustrated in FIG. 4L. The braid angle may influence, for example, the overall radial force of the distal portion 100 as exerted on the walls of the vessel. In some embodiments, the braid angle is in the range of about 45° to about 179°, about 130° to about 160° (e.g., about 151°), about 95° to about 125° (e.g., about 111°, about 112°), etc. Braid angles below about 50° may lack radial strength and/or be too porous. In some embodiments, the average radial resistive force (RRF), which is a measure of the radial outward force that the distal portion 100 exerts as it resists compression, the hoop strength, which is a measure of the ability of a distal portion 100 to withstand radial compressive forces, and/or the chronic outward force (COF), which is a measure of the force that the distal portion 100 exerts as it expands to its expanded state, along the distal portion 100 is between about 2 mm Hg (approx. 0.27 kilopascals (kPa)) and about 50 mm Hg (approx. 6.7 kPa). In some embodiments, the differential force (e.g., COF minus RRF) is sufficient to expand a target vessel between about 0% and about 30% (e.g., between about 0% and about 10%, between about 10% and about 20%, between about 20% and about 30%, and overlapping ranges thereof). In some embodiments, the force of the device (e.g., one or more bulbs) is sufficient to entangle the clot without perforating the vessel.

**[0412]** PPI is an example parameter reflecting how much filament material exists in a square inch (approx. 6.5 cm<sup>2</sup>) of the distal portion 100. FIG. 4N is a schematic side elevational view of an example square inch (approx. 6.5 cm<sup>2</sup>) of an example embodiment of a distal portion 2700 of a vascular treatment device, for example the distal portion 100 of the device 10, 20, 30, or 40. FIG. 4N illustrates a one-over-one-under-one braid pattern with pores 2710 being created by the intersection of a plurality of crossing filaments 156, which may comprise shape memory material and/or radiopaque material. The PPI may range from about 30 PPI to about 300 PPI, about 30 PPI to about 75 PPI (e.g., about 32 PPI, about 57 PPI), about 150 PPI to about 190 PPI (e.g., about 171 PPI), about 75 PPI to about 125 PPI (e.g., about 104 PPI), about 143 PPI to about 171 PPI (e.g., about 157 PPI), about 125 PPI to about 175 PPI (e.g., about 143 PPI), etc. Higher PPI can result in smaller pore size, which can inhibit or prevent debris and small thrombi from being uncaptured, dislodged during capture, and/or released into downstream vasculature (e.g., in the brain). Higher PPI can result in a smaller pore size, which can decrease flow into an aneurysm or a vascular malformation such as an arterio-venous fistula, which can aid in thrombosis of the aneurysm or vascular malformation. Lower PPI can result in a larger pore size, which can allow adequate flow into perforating vessels or small blood vessels, which can maintain flow in these small but important blood vessels. Porosity between about 60% and about 78% may decrease flow into aneurysms or vascular malformations including arterio-venous fistulae and/or permit perfusion to branch vessels.

**[0413]** Pore size is another example parameter reflecting the amount of filament material, and is the size of a hole or aperture or pore created by the intersection of a plurality crossing filaments. Pore dimensions are a corollary to PPI, but they are different in that PPI is a measure of the amount of metal or filaments you would find in a square inch. In embodiments in which the braid pattern is one-over-one-under-one, for example, referring again to FIG. 4N, four crossing filaments may create a quadrilateral-shaped (e.g., rectangle, square, parallelogram, rhombus, diamond, trapezoid) pore. Pores may be large enough to permit perfusion of blood (e.g., at least about 5 microns or micrometers (μm)) to at least about 7 μm should permit red blood cells to pass therethrough), but small enough to trap stroke-causing debris, which generally has a size greater than about 200 μm. In some embodiments, the distal portion 100 comprises pores having a diameter or dimension (e.g., length of a side) between about 0.02 mm<sup>2</sup> and about 1 mm<sup>2</sup>, between about 0.02 mm<sup>2</sup> and about 0.05 mm<sup>2</sup>, or between about 0.02 mm<sup>2</sup> and about 0.025 mm<sup>2</sup>.

**[0414]** In some embodiments, the pore size is substantially uniform across the entire distal portion 100. In some embodiments, the pore size varies across the length of the distal portion 100. For example, the pore size may be substantially uniform along necks and vary along bulbs. For another example, variable pore size may take into account bulbs extending radially outward from necks, and reducing the pore size in the largest dimension areas of the bulbs can help to inhibit debris from being released (e.g., into the brain).

**[0415]** A ratio of the diameter of a filament in the distal portion 100 (e.g., in mm) to the area of the pore between the filaments in the distal portion (e.g., in mm<sup>2</sup>) may be about 1:1 (e.g., in 1/mm), for example on average along the length of the distal portion 100. In some embodiments, the ratio may be about 1:0.5, about 1:0.6, about 1:0.7, about 1:0.8, about 1:0.9, about 1:1, about 1:1.2, about 1:1.3, about 1:1.4, or about 1:1.5. Larger and smaller ratios are also possible.

**[0416]** In some embodiments, increased outward expansile force and/or compression resistance can be provided by a higher braid angle and/or higher PPI. In some embodiments, the force/resistance (e.g., radial force) is in a range sufficient to expand target vessel(s) in the range of about 0% to about 30%. In some embodiments, the total diameter of the distal portion 100 in the expanded state is about 0.5 mm to about 1.5 mm greater than the diameter of the target vessel(s). In some embodiments, the total diameter or size of the distal portion 100 in the expanded state is oversized by about 10% to about 50% with respect to the diameter of the target vessel(s), which can provide radial force sufficient to appose the sidewalls of the vessel and/or slightly expand the vessel and to inhibit debris from flowing between the vessel walls and bulbs of the distal portion 100.

**[0417]** In some embodiments, forming the distal portion 100 includes cutting (e.g., sheared, clipping, trimming, severing, or the like) the distal ends of the filaments of the distal portion 100. In some embodiments, the cut distal ends of the filaments of the distal portion 100 are left loose, with no further treatment. In certain such embodiments, the size of the filaments allows them to be flexible enough to not puncture tissue. In some embodiments, after cutting, the distal ends of the filaments of the distal portion 100 may be treated in a variety of ways. For example, the distal ends of the filaments of the distal portion 100 may be bent back, welded (e.g., ball welded), polished (e.g., to a dull end), coupled in sleeves, dip coated (e.g., in polymer such as polyurethane), coupled (e.g.,

adhered, welded, etc.), for example to an arcuate member (e.g., a radiopaque marker band, for example as illustrated in FIG. 5D), combinations thereof, and the like.

**[0418]** In some embodiments, forming the distal portion **100** includes cutting (e.g., sheared, clipping, trimming, severing, laser cut, combinations thereof, and the like) the proximal ends of the filaments of the distal portion **100**. In some embodiments, the lengths of the distal neck **65**, bulbs, and necks between bulbs have a predetermined length, and the length of an optional neck proximal to the proximal-most bulb can be used to control the total length of the distal portion **100**. The proximal ends of the filaments of the distal portion may be coupled to the proximal portion **200**, as described further herein. The length of the proximal neck may take into account the length of the joint **300**.

**[0419]** In some embodiments, the bulbs are integral with the necks in the distal portion **100**. For example, the plurality of woven filaments may make up the bulbs and the necks between, proximal to, and/or distal to the bulbs. In some embodiments, the filaments may extend continuously longitudinally from a proximal end of the distal portion to a distal end of the distal portion **100**. In some embodiments, the filaments may extend continuously longitudinally for a portion of the distal portion **100** (e.g., including one bulb and one neck, including a plurality of bulbs and a plurality of necks, including a plurality of bulbs and one neck, including one bulb and a plurality of necks, etc.).

**[0420]** In some embodiments, the bulbs are coupled (fixably or reversibly coupled) on or along an elongate support structure (such as a neck, tube, spindle, spine, rod, backbone, etc.). For example, the bulbs may be welded, glued, soldered, dip-coated, spray-coated, combinations thereof, and the like to the elongate support structure. The elongate support structure may be hollow, filled, or partially hollow. The elongate support structure may comprise a wire, a woven tubular member, a hypotube, combinations thereof, and the like. In certain such embodiments, the distal portion **100** may comprise a single elongate support structure or a plurality of elongate support structures (e.g., a series of tubular members between bulbs).

**[0421]** FIGS. 2A, 2B, 3A, 3B, 4A, 4B, and 4I-4K illustrate an optional distal neck **65**, which extends distally from the distal-most bulb. The distal neck **65** may be cylindrical or substantially cylindrical, although the proximal end of the distal neck **65** may flare outwardly to begin the distal-most bulb. In some embodiments, in an expanded configuration, the distal neck **65** has an outer diameter of less than about 0.017 inches (approx. 0.43 mm) and, in a collapsed configuration, has an outer diameter of less than about 0.0125 inches (approx. 0.32 mm). In some embodiments, the distal neck **65** has a diameter in the expanded configuration in the range of about 0.35 mm to about 0.65 mm (e.g., about 0.40 mm to about 0.45 mm). In some embodiments, the distal neck **65** has a diameter in the collapsed configuration in the range of about 0.1 mm to about 0.34 mm (e.g., about 0.25 mm to about 0.33 mm). In some embodiments, for example in which the device is configured to be used in larger vessels (e.g., the leg, outside the brain), the distal neck in the expanded configuration has a diameter in the range of about 1 mm to about 40 mm and in the collapsed configuration has a diameter in the range of about 0.5 mm to about 10 mm. In some embodiments, a ratio of the diameter of the distal neck **65** in the expanded configuration to the diameter of the distal neck **65** in the collapsed configuration is about 1.2:1 to about 10:1. Smaller ratios may be

useful, for example, in smaller vessels, and larger ratios may be useful, for example, in larger vessels. In some embodiments, the distal neck **65** is narrow and has similar outer diameter in the expanded and collapsed configuration. The distal neck **65** may have a length that ranges from about 1 mm to about 5 mm. The length of the distal neck **65** may at least partially depend on the desired usable length of the distal portion **100**, parameters of the bulbs, and/or parameters of the neck. For example, a length of the distal neck **65** may be a multiple of an average length of necks between bulbs (e.g., about 1.5 times to about 2.5 times, e.g., about 2 times). In some embodiments, the distal neck **65** may have a pigtail or other shape that can make the distal neck **65** more atraumatic.

**[0422]** Proximal to the proximal-most bulb, FIGS. 2A, 2B, 3A, 3B, 4A, 4B, and 4I-4K illustrate a proximal portion **200** and a marker band **25**, for example as further discussed herein. Although illustrated in FIGS. 2A, 2B, 3A, 3B, 4A, 4B, and 4I-4K as being coupled to the distal portion **1000**, **1100**, **1200**, **1300**, **1400**, **1500**, **1900**, **2000**, **2100** proximal to the proximal-most bulb as schematically illustrated in FIG. 1A, the proximal portion **200** may be coupled to the distal portion **1000**, **1100**, **1200**, **1300**, **1400**, **1500**, **1900**, **2000**, **2100** distal to the distal-most bulb, for example as schematically illustrated in FIG. 1B, the proximal portion **200** may be coupled to the distal portion **1000**, **1100**, **1200**, **1300**, **1400**, **1500**, **1900**, **2000**, **2100** distal to the distal-most bulb and proximal to the distal end of the proximal portion **200**, for example as schematically illustrated in FIG. 1C, or the proximal portion **200** may be coupled to the distal portion **1000**, **1100**, **1200**, **1300**, **1400**, **1500**, **1900**, **2000**, **2100** proximal to the distal-most bulb, for example as schematically illustrated in FIG. 1D.

**[0423]** FIGS. 2A, 2B, 3A, 3B, 4A, 4B, 4I, 4J, and 4K illustrate example embodiments of distal portions **1000**, **1100**, **1200**, **1300**, **1400**, **1500**, **1900**, **2000**, **2100** in which each of the longitudinal axes of the necks **1020**, **1120**, **1220**, **1320**, **1420**, **1520**, **1920**, **2020**, **2150** is substantially aligned with or substantially the same as the longitudinal axis of the distal portion **1000**, **1100**, **1200**, **1300**, **1400**, **1500**, **1900**, **2000**, **2100**, which in some embodiments can allow the distal portions **1000**, **1100**, **1200**, **1300**, **1400**, **1500**, **1900**, **2000**, **2100** to exert substantially even radial forces on the sidewalls of a vessel being treated. In some embodiments, referring again to FIGS. 4C and 4E, the longitudinal axes **2230**, **2430** of the necks **2220**, **2420** may be non-aligned with longitudinal axes of the distal portion **2200**, **2400**. For example, in embodiments in which the distal portion **2200**, **2400**, comprises spherical bulbs, the longitudinal axes **2230**, **2430** of the necks **2220**, **2420** may be aligned along chords of the spheres, which in some embodiments can allow the distal portions **2200**, **2400** to exert substantially uneven radial forces on the sidewalls of a vessel being treated, which may be useful, for example, to dislodge clots adherent to the endothelium. Each of the following embodiments is possible: coaxially aligned necks with substantially uniform diameter and substantially uniform lengths; coaxially aligned necks with substantially uniform diameter and varying lengths; coaxially aligned necks with varying diameters and substantially uniform lengths; and coaxially aligned necks with varying diameters and varying lengths.

**[0424]** In some embodiments, referring again to FIG. 4E, in which the distal portion **2400** comprises spherical bulbs **2410**, **2415**, the longitudinal axes of the necks may be aligned along different chords of the spheres, for example connecting different parts of the circumferences of the bulbs. For example,

the necks may alternate about 180° between an upper longitude and a lower longitude. For another example, the necks may circumferentially rotate about 90°, about 120°, etc. between each bulb. In some embodiments in which the distal portion 2500 comprises triangular bulbs, the longitudinal axes of the necks may be aligned along different axes of the triangles, referring again to FIG. 4G, for example shifting vertices between each bulb 2510. Phase shifting of the neck positions, or viewed alternatively as phase-shifting of the bulb shapes, along the longitudinal axis of the distal portion 2500 can help to capture stubborn or aged clots.

[0425] FIG. 5A is a schematic side elevational view of another example embodiment of a distal portion 1600 of a vascular treatment device, for example the distal portion 100 of the device 10, 20, 30, or 40. The distal portion 1600 includes, in an expanded state, a cylindrical wide-mouthed textile structure that expands radially outwardly from proximal to distal, and then stays at the larger diameter until the distal end. FIG. 5B is a schematic side elevational view of yet another example of a distal portion 2300 of a vascular treatment device, for example the distal portion 100 of the device 10, 20, 30, or 40. The distal portion 2300 includes, in an expanded state, a proximal neck 70 and a wave-shaped wide-mouthed textile structure that alternately expands radially outwardly to a peak or hill 2310 and radially inward to a valley 2320 from proximal to distal and then stays at the larger diameter until the distal end 75. The expanding section may be generally hemispherical (e.g., as illustrated in FIG. 5A), wave-shaped (e.g., as illustrated in FIG. 5B), tapered, stepped, combinations thereof, and the like. The distal-most bulb of distal portions described herein may be adapted to extend radially outward from the longitudinal axis, increasing in diameter from proximal to distal, reaching an intermediate point, and then staying at the intermediate diameter (e.g., without a distal neck 65). The distal portions 1600, 2300 may be useful, for example, for apposing sidewalls of a vessel along substantially an entire length of a clot and/or for apposing sidewalls of a vessel having an aneurysm or a vascular malformation such as an arterio-venous fistula, which can decrease flow into the aneurysm or the vascular malformation such as an arterio-venous fistula and aiding thrombosis.

[0426] FIG. 5C is a schematic side elevational view of still another example embodiment of a distal portion 1700 of a vascular treatment device, for example the distal portion 100 of the device 10, 20, 30, or 40. The distal portion 1700 includes, in an expanded state, one elongate bulb 1705, a proximal neck 70, and a distal neck 65. FIG. 5D is a schematic side elevational view of still yet another example embodiment of a distal portion 1710 of a vascular treatment device, for example the distal portion 100 of the device 10, 20, 30, or 40. The distal portion 1710 illustrated in FIG. 5D, like the distal portion 1700 illustrated in FIG. 5C, includes one elongate bulb 1705, a proximal neck 70, and a distal neck 65. The distal portion 1710 also includes a radiopaque marker band 1720 coupled to the distal end of the distal neck 65, which may be used to determine the position of the bulb 1705 within a vessel. FIG. 5D also illustrates a radiopaque marker band 25 coupled to the distal end of the proximal portion 200, discussed in further detail herein. The distal portions 1700, 1710 may be useful, for example, for apposing sidewalls of a vessel along substantially an entire length of a clot, and radially inwardly displacing filament ends (e.g., to further reduce the risk of puncturing tissue).

[0427] The mouths, or open end, at the proximal end of the distal portion 100 and at the distal end of the distal portion 100 may be wide (e.g., as illustrated by the distal end of the distal portion 1600 in FIG. 5A, the distal portion 2300 in FIG. 5B) or narrow (e.g., as illustrated by the distal end of the distal portion 1700 in FIG. 5C and the distal end of the distal portion 1710 in FIG. 5D). Each of the following embodiments is possible: a distal portion 100 including a wide mouth at the distal end and a wide mouth at the proximal end; a distal portion 100 including a wide mouth at the distal end and a narrow mouth at the proximal end; a distal portion 100 including a narrow mouth at the distal end and a wide mouth at the proximal end; and a distal portion 100 including a narrow mouth at the distal end and a narrow mouth at the proximal end. A narrow mouth at the distal end of the distal portion 100 can help navigation to increasingly smaller vessels and/or may serve as an atraumatic distal tip. A narrow mouth at the proximal end of the distal portion 100 can help insertion into the distal end of a proximal portion 200 (e.g., as described with respect to FIGS. 20A-23C). A wide mouth at the distal end and the proximal end of the distal portion 100 can help with wall apposition (e.g., the distal end at least partially acting as an embolic filter and/or when the distal portion 100 is used to treat aneurysms or vascular malformations such as arterio-venous fistula).

[0428] FIG. 5E is a schematic side elevational view of another example embodiment of a distal portion 1800 of a vascular treatment device, for example the distal portion 100 of the device 10, 20, 30, or 40. The distal portion 1800 includes, in an expanded state, one generally spherical distal bulb 1802, one generally proximal elongate bulb 1804, a neck 1806 between the bulb 1802 and the bulb 1804, a proximal neck 1809, and a distal neck 65. The neck 1806 has a shorter length than the proximal neck 1809 and the distal neck 1808. FIG. 5E also illustrates a radiopaque marker band 25 coupled to the distal end of the proximal portion 200, discussed in further detail herein. The distal portion 1800 may be useful, for example, for apposing sidewalls of a vessel along substantially an entire length of a clot, providing a distal bulb 1802 that can act as a distal embolic protection device, and radially inwardly displacing filament ends (e.g., to further reduce the risk of puncturing tissue).

[0429] FIG. 5F is a schematic side elevational view of yet another example embodiment of a distal portion 1810 of a vascular treatment device, for example the distal portion 100 of the device 10, 20, 30, or 40. The distal portion 1810 includes, in an expanded state, one generally spherical distal bulb 1812, one generally spherical proximal bulb 1816, one generally elongate bulb 1814 between the bulb 1812 and the bulb 1816, necks 1818 between the bulbs 1812, 1814 and between the bulbs 1814, 1816, a proximal neck 1819, and a distal neck 65. FIG. 5F also illustrates a radiopaque marker band 25 coupled to the distal end of the proximal portion 200, discussed in further detail herein. The distal portion 1810 may be useful, for example, for apposing sidewalls of a vessel along substantially an entire length of a clot, providing a distal bulb 1812 that can act as a distal embolic protection device, providing a proximal spherical bulb 1816 that can be optionally deployed if a clot is longer than expected, and radially inwardly displacing filament ends (e.g., to further reduce the risk of puncturing tissue).

[0430] FIGS. 4A, 4B, 5E, and 5F show example embodiments of a pattern of bulb shapes in which at least one of the bulbs 1412 in FIG. 4A, at least one of the bulbs 1511 in FIG.

4B, at least one of the bulbs **1802** in FIG. 5E, and at least one of the bulbs **1812** in FIG. 5F has a shape different than at least one of the other bulbs **1414** in FIG. 4A, at least one of the other bulbs **1531** in FIG. 4B, at least one of the other bulbs **1804** in FIG. 5E, and at least one of the other bulbs **1814** in FIG. 5F, respectively. With reference to FIG. 4B, this different or combination shape pattern persists even when the bulbs have different sizes. In the embodiments illustrated in FIGS. 4A, 4B, 5E, and 5F, some of the bulbs **1412**, **1511**, **1802**, **1812** are spherical and some of the bulbs **1414**, **1531**, **1804**, **1814** are oblong, but distal portions **100** including bulbs having other combinations of shapes are also possible.

[0431] FIG. 5G is a schematic side elevational view of still another example embodiment of a distal portion **1820** of a vascular treatment device, for example the distal portion **100** of the device **10**, **20**, **30**, or **40**. The distal portion **1820** includes, in an expanded state, one generally elongate distal bulb **1822**, one generally elongate proximal bulb **1826**, one generally elongate bulb **1824** between the bulb **1822** and the bulb **1826**, necks **1828** between the bulbs **1822**, **1824** and between the bulbs **1824**, **1826**, a proximal neck **1829**, and a distal neck **65**. FIG. 5G also illustrates a radiopaque marker band **25** coupled to the distal end of the proximal portion **200**, discussed in further detail herein. The bulb **1824** is longer than the bulbs **1822**, **1826**. The distal portion **1820** may be useful, for example, for apposing sidewalls of a vessel along substantially an entire length of a clot, providing a distal bulb **1822** that can act as a distal embolic protection device, providing a proximal bulb **1826** that can be optionally deployed if a clot is longer than expected, and radially inwardly displacing filament ends (e.g., to further reduce the risk of puncturing tissue).

[0432] FIG. 6A is a schematic side elevational view of another example embodiment of a distal portion **9000** of a vascular treatment device, for example the distal portion **100** of the device **10**, **20**, **30**, or **40**. The distal portion **9000** includes, in an expanded state, a plurality of woven bulbs **9003**, **9005**, **9007** and necks **9020** with braid angles that vary along the length of the distal portion **9000**. The distal portion **9000** includes, in an expanded state, one generally spherical distal bulb **9003**, one generally spherical proximal bulb **9007**, one generally elongate bulb **9005** between the bulb **9003** and the bulb **9007**, a neck **9014** between the bulbs **9003**, **9005**, a neck **9016** between the bulbs **9005**, **9007**, a wide-mouth proximal neck **9018**, and a wide-mouth distal neck **9012**. In some embodiments, the distal portion **9000** includes a plurality of segments, at least one of which has a different braid angle. The distal portion **9000** illustrated in FIG. 6A includes a proximal segment **9006** having a relatively low braid angle, a middle segment **9002** having a relatively high braid angle, and a distal segment **9004** having a relatively low braid angle **9004**. In some embodiments, segments **9004**, **9006** may have braid angles ranging from about  $0^\circ$  to about  $90^\circ$  (e.g., about  $17^\circ$ , about  $22^\circ$ , about  $45^\circ$ , etc.). Lower braid angle segments generally have lower PPI and tend to be more porous. Lower PPI can result in a larger pore size, which can allow adequate flow into perforating vessels or small blood vessels adjoining an aneurysm or a vascular malformation such as an arterio-venous fistula, which can maintain flow in these small but important blood vessels. In some embodiments, the segment **9002** may have braid angles ranging from about  $91^\circ$  to about  $180^\circ$  (e.g., about  $111^\circ$ , about  $112^\circ$ , about  $151^\circ$ , etc.). Higher braid angle segments generally have a higher PPI and tend to be less porous. Higher PPI can result in a smaller pore size,

which can decrease flow into an aneurysm or a vascular malformation such as an arterio-venous fistula, which can aid in thrombosis of the aneurysm or vascular malformation. The bulbs have substantially uniform dimensions or diameters (e.g., within about  $\pm 5\%$ , about  $\pm 10\%$ , about  $\pm 15\%$ , or about  $20\%$  of each other) such that the distal portion **9000** may be considered non-tapered.

[0433] FIG. 6B is a schematic side elevational view of yet another example embodiment of a distal portion **9100** of a vascular treatment device, for example the distal portion **100** of the device **10**, **20**, **30**, or **40**. The distal portion **9100** includes, in an expanded state, a plurality of woven bulbs **9103**, **9105**, **9107** and necks **9115** having braid angles that vary along the length of the distal portion **9100**. In some embodiments, the distal portion **9100** includes, in an expanded state, one generally spherical distal bulb **9103**, one generally spherical proximal bulb **9107**, one generally elongate bulb **9105** between the bulb **9103** and the bulb **9107**, a neck **9114** between the bulbs **9103**, **9105**, a neck **9116** between the bulbs **9105**, **9107**, a wide-mouth proximal neck **9118**, and a wide-mouth distal neck **9112**. The distal portion **9100** illustrated in FIG. 6B includes a proximal segment **9120** having a relatively low braid angle and a distal segment **9110** having a relatively high braid angle. In some embodiments, the segment **9120** may have braid angles ranging from about  $0^\circ$  to about  $90^\circ$  (e.g., about  $17^\circ$ , about  $22^\circ$ , about  $45^\circ$ , etc.). Lower braid angle segments generally have lower PPI and tend to be more porous. Lower PPI can result in a larger pore size, which can allow adequate flow into perforating vessels or small blood vessels adjoining an aneurysm or a vascular malformation such as an arterio-venous fistula, which can maintain flow in these small but important blood vessels. In some embodiments, the segment **9110** may have braid angles ranging from about  $91^\circ$  to about  $180^\circ$  (e.g., about  $111^\circ$ , about  $112^\circ$ , about  $151^\circ$ , etc.). Higher braid angle segments generally have a higher PPI and tend to be less porous. Higher PPI can result in a smaller pore size, which can decrease flow into an aneurysm or a vascular malformation such as an arterio-venous fistula, which can aid in thrombosis of the aneurysm or vascular malformation. The bulbs have substantially uniform dimensions or diameters (e.g., within about  $\pm 5\%$ , about  $\pm 10\%$ , about  $\pm 15\%$ , or about  $20\%$  of each other) such that the distal portion **9100** may be considered non-tapered.

[0434] FIG. 6C is a schematic side elevational view of still another example embodiment of a distal portion **9200** of a vascular treatment device, for example the distal portion **100** of the device **10**, **20**, **30**, or **40**. The distal portion **9200** includes, in an expanded state, a plurality of woven bulbs **9203**, **9205**, **9207** and necks **9215** having braid angles that vary along the length of the distal portion **9200**. The distal portion **9200** includes, in an expanded state, one generally spherical distal bulb **9203**, one generally spherical proximal bulb **9207**, one generally elongate bulb **9205** between the bulb **9203** and the bulb **9207**, a neck **9214** between the bulbs **9203**, **9205**, a neck **9216** between the bulbs **9205**, **9207**, a wide-mouth proximal neck **9218**, and a wide-mouth distal neck **9212**. In some embodiments, the distal portion **9200** includes a plurality of segments, at least one of which has a different braid angle. The distal portion **9200** illustrated in FIG. 6C includes a distal segment **9210** having a relatively low braid angle and a proximal segment **9220** having a relatively high braid angle. In some embodiments, the segment **9210** may have braid angles ranging from about  $0^\circ$  to about  $90^\circ$  (e.g., about  $17^\circ$ , about  $22^\circ$ , about  $45^\circ$ , etc.). Lower braid angle

segments generally have lower PPI and tend to be more porous. Lower PPI can result in a larger pore size, which can allow adequate flow into perforating vessels or small blood vessels adjoining an aneurysm or a vascular malformation such as an arterio-venous fistula, which can maintain flow in these small but important blood vessels. In some embodiments, the segment 9220 may have braid angles ranging from about 91° to about 180° (e.g., about 111°, about 112°, about 151°, etc.). Higher braid angle segments generally have a higher PPI and tend to be less porous. Higher PPI can result in a smaller pore size, which can decrease flow into an aneurysm or a vascular malformation such as an arterio-venous fistula, which can aid in thrombosis of the aneurysm or vascular malformation. The bulbs have substantially uniform dimensions or diameters (e.g., within about ±5%, about ±10%, about ±15%, or about 20% of each other) such that the distal portion 9200 may be considered non-tapered.

[0435] FIG. 6D is a schematic side elevational view of still yet another example embodiment of a distal portion 9300 of a vascular treatment device, for example the distal portion 100 of the device 10, 20, 30, or 40. The distal portion 9300 includes, in an expanded state, a plurality of woven bulbs 9303, 9305, 9307 and necks 9315 having braid angles that vary along the length of the distal portion 9300. The distal portion 9300 includes, in an expanded state, one generally spherical distal bulb 9303, one generally spherical proximal bulb 9307, one generally elongate bulb 9305 between the bulb 9303 and the bulb 9307, a neck 9314 between the bulbs 9303, 9305, a neck 9316 between the bulbs 9305, 9307, a wide-mouth proximal neck 9318, and a wide-mouth distal neck 9312. In some embodiments, the distal portion 9300 includes a plurality of segments, at least one of which has a different braid angle. The distal portion 9300 illustrated in FIG. 6D includes a proximal segment 9306 having a relatively high braid angle, a middle segment 9320 having a relatively low braid angle, and a distal segment 9304 having a relatively high braid angle. In some embodiments, the segment 9320 may have braid angles ranging from about 0° to about 90° (e.g., about 17°, about 22°, about 45°, etc.). Lower braid angle segments generally have lower PPI and tend to be more porous. Lower PPI can result in a larger pore size, which can allow adequate flow into perforating vessels or small blood vessels adjoining an aneurysm or a vascular malformation such as an arterio-venous fistula, which can maintain flow in these small but important blood vessels. In some embodiments, the segments 9304, 9306 may have braid angles ranging from about 91° to about 180° (e.g., about 111°, about 112°, about 151°, etc.). Higher braid angle segments generally have a higher PPI and tend to be less porous. Higher PPI can result in a smaller pore size, which can decrease flow into an aneurysm or a vascular malformation such as an arterio-venous fistula, which can aid in thrombosis of the aneurysm or vascular malformation. The bulbs have substantially uniform dimensions or diameters (e.g., within about ±5%, about ±10%, about ±15%, or about 20% of each other) such that the distal portion 9300 may be considered non-tapered.

[0436] FIG. 6E is a schematic side elevational view of another example embodiment of a distal portion 9400 of a vascular treatment device, for example the distal portion 100 of the device 10, 20, 30, or 40. The distal portion 9400 includes, in an expanded state, a plurality of woven bulbs 9403, 9405, 9407 and necks 9415 having braid angles that vary along the length of the distal portion 9400. The distal portion 9400 includes, in an expanded state, one generally

spherical distal bulb 9403, one generally spherical proximal bulb 9407, one generally elongate bulb 9405 between the bulb 9403 and the bulb 9407, a neck 9414 between the bulbs 9403, 9405, a neck 9416 between the bulbs 9405, 9407, a wide-mouth proximal neck 9418, and a wide-mouth distal neck 9412. In some embodiments, the distal portion 9400 includes a plurality of segments, at least one of which has a different braid angle. The distal portion 9400 illustrated in FIG. 6E includes a proximal segment 9404 having a relatively low braid angle, a segment 9408 having a medium braid angle, a middle segment 9430 having a relatively high braid angle, a segment 9406 having a medium braid angle, and a distal segment 9402 having a relatively low braid angle. In some embodiments, the lower braid angle segments 9402, 9404 may have braid angles ranging from about 0° to about 80° (e.g., about 17°, about 22°, about 45°, etc.). Lower braid angle segments generally have lower PPI and tend to be more porous. Lower PPI can result in a larger pore size, which can allow adequate flow into perforating vessels or small blood vessels adjoining an aneurysm or a vascular malformation such as an arterio-venous fistula, which can maintain flow in these small but important blood vessels. In some embodiments, the higher braid angle segment 9430 may have braid angles ranging from about 111° to about 180° (e.g., about 111°, about 112°, about 151°, etc.). Higher braid angle segments generally have a higher PPI and tend to be less porous. Higher PPI can result in a smaller pore size, which can decrease flow into an aneurysm or a vascular malformation such as an arterio-venous fistula, which can aid in thrombosis of the aneurysm or vascular malformation. In some embodiments, the medium braid angle segments 9406, 9408 may have braid angles ranging from about 81° to about 110° (e.g., about 90°, about 105°, etc.). Medium braid angle segments generally have moderate pore size and avoid for abrupt transitions in pore size, which can allow for operator error in adequate placement of the flow diverters across aneurysms and blood vessels. The bulbs have substantially uniform dimensions or diameters (e.g., within about ±5%, about ±10%, about ±15%, or about 20% of each other) such that the distal portion 9400 may be considered non-tapered.

[0437] The variable porosities described for example with respect to FIGS. 6A-6E can be combined with bulbs and necks as described herein, for example, the plurality of woven bulbs and necks illustrated in FIGS. 6F and 6G as described herein.

[0438] FIG. 6F is a schematic side elevational view of yet another example embodiment of a distal portion 9500 of a vascular treatment device, for example the distal portion 100 of the device 10, 20, 30, or 40. The distal portion 9500 includes a plurality of woven bulbs 9503, 9505, 9507 and woven necks 9520. The distal portion 9500 includes, in an expanded state, one generally spherical distal bulb 9503, one generally spherical proximal bulb 9507, one generally elongate bulb 9505 between the bulb 9503 and the bulb 9507, a neck 9514 between the bulbs 9503, 9505, a neck 9516 between the bulbs 9505, 9507, a wide-mouth proximal neck 9518, and a wide-mouth distal neck 9512. In some embodiments, the distal portion 9500 includes a plurality of segments, at least one of which has a different braid angle. The distal portion 9500 illustrated in FIG. 6F includes a proximal segment 9506 having a relatively low braid angle, a middle segment 9504 having a relatively high braid angle, and a distal segment 9502 having a relatively low braid angle. In some embodiments, the lower braid angle segments 9502, 9506

may have braid angles ranging from about 0° to about 90° (e.g., about 17°, about 22°, about 45°, etc.). Lower braid angle segments generally have lower PPI and tend to be more porous. Lower PPI can result in a larger pore size, which can allow adequate flow into perforating vessels or small blood vessels adjoining an aneurysm or a vascular malformation such as an arterio-venous fistula, which can maintain flow in these small but important blood vessels. In some embodiments, the higher braid angle segment **9504** may have braid angles ranging from about 91° to about 180° (e.g., about 111°, about 112°, about 151°, etc.). Higher braid angle segments generally have a higher PPI and tend to be less porous. Higher PPI can result in a smaller pore size, which can decrease flow into an aneurysm or a vascular malformation such as an arterio-venous fistula, which can aid in thrombosis of the aneurysm or vascular malformation. The bulbs **9510** have substantially uniform dimensions or diameters (e.g., within about ±5%, about ±10%, about ±15%, or about 20% of each other) such that the distal portion **9500** may be considered non-tapered.

[0439] FIG. 6G is a schematic side elevational view of still another example embodiment of a distal portion **9600** of a vascular treatment device, for example the distal portion **100** of the device **10**, **20**, **30**, or **40**. The distal portion **9600** includes a plurality of woven bulbs **9610** and woven necks **9620**. The distal portion **9600** includes, in an expanded state, one generally spherical distal bulb **9603**, one generally elongate proximal bulb **9607**, one generally spherical bulb **9605** between the bulb **9603** and the bulb **9607**, a neck **9614** between the bulbs **9603**, **9605**, a neck **9616** between the bulbs **9605**, **9607**, a proximal neck **9618**, and a distal neck **9612**. In some embodiments, the distal portion **9600** includes a plurality of segments, at least one of which has a different braid angle. The distal portion **9600** illustrated in FIG. 6G includes a proximal segment **9604** having a relatively high braid angle and a distal segment **9602** having a relatively low braid angle. In some embodiments, the lower braid angle segment **9602** may have braid angles ranging from about 0° to about 90° (e.g., about 17°, about 22°, about 45°, etc.). Lower braid angle segments generally have lower PPI and tend to be more porous. Lower PPI can result in a larger pore size, which can allow adequate flow into perforating vessels or small blood vessels adjoining an aneurysm or a vascular malformation such as an arterio-venous fistula, which can maintain flow in these small but important blood vessels. In some embodiments, the higher braid angle segment **9604** may have braid angles ranging from about 91° to about 180° (e.g., about 111°, about 112°, about 151°, etc.). Higher braid angle segments generally have a higher PPI and tend to be less porous. Higher PPI can result in a smaller pore size, which can decrease flow into an aneurysm or a vascular malformation such as an arterio-venous fistula, which can aid in thrombosis of the aneurysm or vascular malformation.

[0440] In some embodiments, the outer diameters of the bulbs **9610** in the radially-expanded configuration are as follows: the distal medium spherical bulb **9603** has an outer diameter configured to be oversized to the medium vessel segments such as the proximal M1 segment of the middle cerebral artery (e.g., about 2.75 mm to about 3.25 mm); the middle extra-large spherical bulb **9605** has an outer diameter configured to be oversized by about 25% to about 50% of the largest diameter of one of the bifurcation of vessels such as the internal carotid artery bifurcation (e.g., about 5 mm to about 6 mm); and the proximally-next large elongate bulb

**9607** has an outer diameter configured to be oversized to the large vessel segments such as the distal supra-clinoid segment of the internal carotid artery (e.g., about 3.25 mm to about 4 mm). Although some example diameters are provided herein, some embodiments of the distal portion **9600** may include diameters of the bulbs **9603**, **9605**, **9607** in accordance with the values provided above and/or diameters that are within about ±5%, about ±10%, about ±15%, or about ±20% of any such values.

[0441] FIG. 6H is a schematic side elevational view of still yet another example embodiment of a distal portion **11300** of a vascular treatment device, for example the distal portion **100** of the device **10**, **20**, **30**, or **40**. The distal portion **11300** includes, in an expanded state, a plurality of woven bulbs **11323**, **11325**, **11327** and necks **11330** including a plurality of segments having variable pore size along the length of the distal portion **11300**. The distal portion **11300** includes, in an expanded state, one generally spherical distal bulb **11323**, one generally spherical proximal bulb **11327**, one generally elongate bulb **11325** between the bulb **11323** and the bulb **11327**, a neck **11324** between the bulbs **11323**, **11325**, a neck **11326** between the bulbs **11325**, **11327**, a wide-mouth proximal neck **11328**, and a wide-mouth distal neck **11322**. In some embodiments, the distal portion **11300** includes a proximal segment **11315** having a relatively low braid angle and relatively higher porosity and a distal segment **11305** having a relatively low braid angle and relatively higher porosity. The middle segment **11310** includes a first portion **11311** on one side of the longitudinal axis **4640** having a relatively low braid angle and that is relatively more porous and a second portion **11312** another side of the longitudinal axis **4640** having a relatively high braid angle and that is relatively less porous, which may be achieved, for example, by varying speed of rotation of the two hemispheres of the circular horn gear or yarn wheel used for braiding the textile structure **11300**.

[0442] In some embodiments, the speed of rotation of the circular horn gear or yarn wheel for 180° rotation of the yarn wheel, for example the speed of rotation of the western hemisphere ( $S_{h-w}$ ) of spindles on the yarn wheel, is different compared to the remaining 180° rotation of the yarn wheel, for example the eastern hemisphere ( $S_{h-e}$ ) of spindles of the yarn wheel. In certain such embodiments, the pore size can be varied in the vertical plane on either side of the longitudinal axis **4640**. In some embodiments, for example if the speed of rotation in the horizontal direction of the western hemisphere ( $S_{h-w}$ ) of the circular horn gear is faster than the speed of motion in the vertical direction ( $S_v$ ) of the puller (e.g., when the horn gear ratio ( $S_{h-w}/S_v$ ) is greater than 1.0), a high braid angle can be obtained. For example, the higher braid angle portion **11312** of the middle segment **11310** may have braid angles ranging from about 91° to about 180° (e.g., about 111°, about 112°, about 151°, etc.). Higher braid angle segments generally have a higher PPI and tend to be less porous. Higher PPI can result in a smaller pore size, which can decrease flow into an aneurysm or a vascular malformation such as an arterio-venous fistula, which can aid in thrombosis of the aneurysm or vascular malformation. In some embodiments, for example if the speed of rotation in the horizontal direction of the eastern hemisphere ( $S_{h-e}$ ) of the circular horn gear is slower than the speed of motion in the vertical direction ( $S_v$ ) of the puller (e.g., when the horn gear ratio ( $S_{h-e}/S_v$ ) is less than 1.0), a low braid angle can be obtained. For example, the first portion **11311** of the middle segment **11310** and the low

braid angle segments **11305**, **11315** may have braid angles ranging from about  $0^\circ$  to about  $90^\circ$  (e.g., about  $17^\circ$ , about  $22^\circ$ , about  $45^\circ$ , etc.).

[0443] In some embodiments, for example if the speed of rotation in the horizontal direction of the circular horn gear ( $S_h$ ) is slower than the speed of motion in the vertical direction ( $S_v$ ) of the puller wherein the speed of rotation of both hemispheres of the circular horn gear are the same ( $S_{h-w}=S_{h-e}$ ) (e.g., when the horn gear ratio ( $S_h/S_v$ ) is less than 1.0), a low braid angle can be obtained. Lower braid angle segments generally have lower PPI and tend to be more porous. Lower PPI can result in a larger pore size, which can allow adequate flow into perforating vessels or small blood vessels adjoining an aneurysm or a vascular malformation such as an arterio-venous fistula, which can maintain flow in these small but important blood vessels. Although some example embodiments are provided herein, some embodiments of the distal portion **11300** may include one or more segments with variable pore size, combinations thereof, and the like. The bulbs have substantially uniform dimensions or diameters (e.g., within about  $\pm 5\%$ , about  $\pm 10\%$ , about  $\pm 15\%$ , or about  $20\%$  of each other) such that the distal portion **11300** may be considered non-tapered. In some embodiments, the force/resistance (e.g., radial force) of the bulbs and/or necks is in a range sufficient to slightly expand the target vessel(s) in the range of about  $0\%$  to about  $30\%$ , and the shapes of the bulbs and necks are at least partially preserved. In some embodiments, the radial force of the bulbs and/or necks is in a range sufficient to appose the sidewalls of the vessel to inhibit or prevent an endo-leak, but not sufficient to expand the vessel, and the shapes of the bulbs and necks are no longer preserved such that the shape of the distal portion **11300** is substantially tubular, whether tapered or non-tapered, for example based on the shape of the target vessel.

[0444] FIG. 6I is a schematic side elevational view of another example embodiment of a distal portion **11350** of a vascular treatment device, for example the distal portion **100** of the device **10**, **20**, **30**, or **40**. The distal portion **11350** includes, in an expanded state, a plurality of woven bulbs **11353**, **11355**, **11357** and necks **11370**. The distal portion **11350** includes, in an expanded state, one generally spherical distal bulb **11353**, one generally spherical proximal bulb **11357**, one generally elongate bulb **11355** between the bulb **11353** and the bulb **11357**, a neck **11364** between the bulbs **11353**, **11355**, a neck **11366** between the bulbs **11355**, **11357**, a wide-mouth proximal neck **11368**, and a wide-mouth distal neck **11362**. The distal portion **11350** is aligned along a longitudinal axis **4640**. The longitudinal axis **4640** may run through a center of the distal portion **11350**. The bulb **11355** may be hemi-spherical or generally hemi-spherical along the longitudinal axis **4640**. In some embodiments, the bulb **11355** is hemispherical, trapezoidal, generally hemi-spherical, or generally trapezoidal so that the bulb **11355** appears as a bulge on one side of the distal portion **11350**.

[0445] In some embodiments, the woven bulb **11355** or a portion thereof (e.g., one side) that bulges on the side of the distal portion **11350** may be dip-coated or spray coated with a polymer **11360** (e.g., silicone, polyurethane (e.g., Polyslix, available from Duke Extrusion of Santa Cruz, Calif.), polyethylene (e.g., Rexell®, available from Huntsman) including low density polyethylene (LDPE), linear low density polyethylene (LLDPE), medium density polyethylene (MDPE), and high density polyethylene (HDPE), fluoropolymers such as fluorinated ethylene propylene, PFA, MFA, PVDF, THV,

ETFE, PCTFE, ECTFE (e.g., Teflon® FEP, available from DuPont), polypropylene, polyesters including polyethylene terephthalate (PET), PBT, PETG (e.g., Hytrel®, available from DuPont), PTFE, combination polymer compounds such as thermoplastic polyurethanes and polyether block amides (e.g., Propell™ available from Foster Corporation of Putnam, Conn.), polyether block amides (e.g. Pebax® available from Arkema of Colombes, France, PebaxSlix, available from Duke Extrusion of Santa Cruz, Calif.), polyether soft blocks coupled with polyester hard blocks vinyls such as PVC, PVDC, polyimides (e.g., polyimides available from MicroLumen of Oldsmar, Fla.), polyamides (e.g., Durethan, available from Bayer, Nylon 12, available from Duke Extrusion of Santa Cruz, Calif.), polycarbonate (e.g., Corethane™, available from Corvita Corp. of Miami, Fla.), styrenics such as PS, SAN, ABS, and HIPS, acetals such as copolymers or homopolymers, PLA, PGA, PLGA, PCL, polyorthoesters, polyanhydrides, and copolymers thereof, high temperature performance polymers such as PEEK, PES, PPS, PSU, LCP, combinations thereof, and the like). In some embodiments, the polymer may include a radiopaque material (e.g., particles of radiopaque material dispersed in the polymer). In some embodiments, masking a portion of the bulb section of the distal portion **11350** during dip coating or spray coating can inhibit polymer from depositing in the area of masking. For example, if the distal portion **11350** is dip coated or spray coated while still on a mandrel, the polymer may be inhibited from being deposited on the inside of the distal portion **11350**, which can maintain an inner diameter of the distal portion **11350**.

[0446] In some embodiments, the distal portion **11350** includes plurality of woven filaments having a relatively low braid angle, for example ranging from about  $0^\circ$  to about  $90^\circ$  (for e.g., about  $17^\circ$ , about  $22^\circ$ , about  $45^\circ$ , etc.). Lower braid angle segments generally have lower PPI and tend to be more porous. Lower PPI can result in a larger pore size, which can allow adequate flow into perforating vessels or small blood vessels adjoining an aneurysm or a vascular malformation such as an arterio-venous fistula, which can maintain flow in these small but important blood vessels. In some embodiments, the bulb **11355** that is dip coated or spray coated with a polymer **11360** may be non-porous, which can decrease flow into an aneurysm or a vascular malformation such as an arterio-venous fistula, which can aid in thrombosis of the aneurysm or vascular malformation. The distal portion **11350** may be useful, for example, for deployment of the non-porous polymer coated bulb **11355** across a side-wall basilar arterial brain aneurysm, which can aid in thrombosis of the aneurysm. The deployment of the rest of the distal portion **11350** having a relatively high pore size, across arteries on either side of the aneurysm can allow blood flow into these arteries, for example the anterior-inferior cerebellar arteries proximally, the basilar perforators on the other side of the aneurysm, and/or the superior cerebellar arteries distally, and which can inhibit or prevent occlusion of the basilar perforators and the other branches and/or resulting dysfunction, which could otherwise cause a brainstem stroke, paralysis of the arms, and/or paralysis of the legs. The bulbs have substantially uniform dimensions or diameters (e.g., within about  $\pm 5\%$ , about  $\pm 10\%$ , about  $\pm 15\%$ , or about  $20\%$  of each other) such that the distal portion **11350** may be considered non-tapered.

[0447] FIG. 6J is a schematic side elevational view of still yet another example embodiment of a distal portion **9900** of



a vascular treatment device, for example the distal portion **100** of the device **10**, **20**, **30**, or **40**. The distal portion **9900** includes a plurality of woven bulbs **9910** and woven necks **9920**. The distal portion **9900** includes, in an expanded state, one generally spherical distal bulb **9903**, one generally spherical proximal bulb **9907**, one generally elongate bulb **9905** between the bulb **9903** and the bulb **9907**, a neck **9914** between the bulbs **9903**, **9905**, a neck **9916** between the bulbs **9905**, **9907**, a wide-mouth proximal neck **9918** with a diameter **9930**, and a wide-mouth distal neck **9912** with a diameter **9925**. In some embodiments, the distal portion **9900** includes a plurality of segments, at least one of which has a different braid angle. The distal portion **9900** illustrated in FIG. 6J includes a proximal segment **9906** having a relatively low braid angle, a middle segment **9904** having a relatively high braid angle, and a distal segment **9902** having a relatively low braid angle. In some embodiments, the lower braid angle segments **9902**, **9906** may have braid angles ranging from about  $0^\circ$  to about  $90^\circ$  (e.g., about  $17^\circ$ , about  $22^\circ$ , about  $45^\circ$ , etc.). Lower braid angle segments generally have lower PPI and tend to be more porous. Lower PPI can result in a larger pore size, which can allow adequate flow into perforating vessels or small blood vessels adjoining an aneurysm or a vascular malformation such as an arterio-venous fistula, which can maintain flow in these small but important blood vessels. In some embodiments, the higher braid angle segment **9904** may have braid angles ranging from about  $91^\circ$  to about  $180^\circ$  (e.g., about  $111^\circ$ , about  $112^\circ$ , about  $151^\circ$ , etc.). Higher braid angle segments generally have a higher PPI and tend to be less porous. Higher PPI can result in a smaller pore size, which can decrease flow into an aneurysm or a vascular malformation such as an arterio-venous fistula, which can aid in thrombosis of the aneurysm or vascular malformation.

[0448] In some embodiments, the outer diameters of the bulbs **9910** in the radially-expanded configuration are as follows: the distal extra-large spherical bulb **9603** has an outer diameter configured to be oversized by about 25% to about 50% to the diameter of the transverse-sigmoid cerebral venous sinus (e.g., about 8 mm to about 12 mm, about 10 mm); the middle elongate bulb **9905** has an outer diameter configured to be oversized by about 25% to about 50% to the diameter of the sigmoid cerebral venous sinus (e.g., about 6 mm to about 10 mm, about 9 mm); and the proximally-next spherical bulb **9907** has an outer diameter configured to be oversized to the junction of the sigmoid venous sinus and the internal jugular vein at the base of skull (e.g., about 6 to about 10 mm, about 8 mm). Although some example diameters are provided herein, some embodiments of the distal portion **9900** may include diameters of the bulbs **9903**, **9905**, **9907** in accordance with the values provided above and/or diameters that are within about  $\pm 5\%$ , about  $\pm 10\%$ , about  $\pm 15\%$ , or about  $\pm 20\%$  of any such values, such that the distal portion **9900** may be considered to be tapered.

[0449] FIG. 7A is a schematic side elevational view of still another example embodiment of a distal portion **11000** of a vascular treatment device, for example the distal portion **100** of the device **10**, **20**, **30**, or **40**. The distal portion **11000** includes a plurality of woven bulbs and woven necks. The distal portion **11000** includes, in an expanded state, one generally spherical distal bulb or central anchor bulb **11012**, one generally spherical proximal bulb **11014**, a neck **11016** between the bulbs **11012**, **11014**, a proximal neck **11017**, a distal medial neck **11018**, and a distal lateral neck **11019**. The bulb **11012** has a diameter  $D_0$ . In some embodiments, the

neck **11016** between the two bulbs **11012**, **11014**, the elongate proximal bulb **11014**, and the proximal neck **11017** form a proximal segment having a length  $L_3$ . The neck **11017** has a wide mouth and a diameter  $D_3$ . The distal medial neck **11018** is relatively short, having a length  $L_2$ , and has a diameter  $D_2$ . The distal lateral neck **11019** has a length  $L_1$  and has a diameter  $D_1$ .

[0450] In some embodiments, the distal spherical bulb **11012** has a relatively high braid angle and the rest of the distal portion **11000** has a relatively low braid angle. Lower braid angle segments generally have lower PPI and tend to have relatively high porosity. Lower PPI can result in a larger pore size, which can allow adequate flow into perforating vessels or small blood vessels adjoining an aneurysm or a vascular malformation such as an arterio-venous fistula, which can maintain flow in these small but important blood vessels. In some embodiments, the proximal segment has a relatively low braid angle. Higher braid angle segments generally have a higher PPI and tend to have relatively low porosity. Higher PPI can result in a smaller pore size, which can decrease flow into an aneurysm or a vascular malformation such as an arterio-venous fistula, which can aid in thrombosis of the aneurysm or vascular malformation.

[0451] In some embodiments, the outer diameters of the bulbs and necks in the radially-expanded configuration are as follows:  $D_1$  is configured to be oversized to the medium vessel segments such as the proximal M1 segment of the middle cerebral artery (e.g., about 2.75 mm to about 3.25 mm);  $D_2$  is configured to be oversized to the medium vessel segments such as the proximal A1 segment of the anterior cerebral artery (e.g., about 2.25 mm to about 2.75 mm);  $D_0$  is configured to be oversized by about 25% to about 50% of the largest diameter of one of the bifurcation of vessels such as the internal carotid artery bifurcation (e.g., about 5 mm to about 6 mm); and  $D_3$  is configured to be oversized to the large vessel segments such as the distal supra-clinoid segment of the internal carotid artery (e.g., about 3.25 mm to about 4 mm). Although some example diameters are provided herein, some embodiments of the distal portion **11000** may include diameters of the bulbs **11012**, **11014** and necks **11016**, **11017**, **11018**, **11019** in accordance with the values provided above and/or diameters that are within about  $\pm 5\%$ , about  $\pm 10\%$ , about  $\pm 15\%$ , or about  $\pm 20\%$  of any such values.

[0452] Although the necks **11017**, **11018**, **11019** are illustrated in FIG. 7A as being in the same plane (e.g., the plane of the page or the screen), the necks **11017**, **11018**, **11019** may be in different planes, for example based on certain vasculature. In contrast to pure balls deployed at bifurcations, necks **11017**, **11018**, **11019** can preserve anatomy for later procedures. For example, a thrombectomy device could be inserted through the neck **11017** and then into the vessel in which the neck **11018** resides and/or in which the neck **11019** resides. Certain distal portions described herein can be described as an endoprosthesis, a stent, etc. A proximal portion can be attached to endoprosthesis through detachable joint (e.g., Guglielmi electrolytic detachment, mechanical detachment, etc.).

[0453] FIG. 7B is a schematic side elevational view of still yet another example embodiment of a distal portion **11100** of a vascular treatment device, for example the distal portion **100** of the device **10**, **20**, **30**, or **40**. The distal portion **11100** includes a plurality of woven bulbs and woven necks. The distal portion **11100** includes, in an expanded state, one generally spherical or ovoid proximal bulb **11105** having a diam-

eter  $D_0$ , one generally elongate distal bulb **1110**, a neck **1115** between the bulbs **1105**, **1110**, a wide-mouth distal neck **1130** having a diameter  $D_3$ , a proximal medial neck **1125**, and a proximal lateral neck **1120**. In some embodiments, the neck **1115**, the elongate distal bulb **1110**, and the distal neck **1130** form a distal segment having a length  $L_3$ . The proximal medial neck **1125** is short, having a length  $L_2$ , and has a narrow mouth having a diameter  $D_2$ . The proximal lateral neck **1120** is short, having a length  $L_1$ , and has a narrow mouth having a diameter  $D_1$ .

[0454] In some embodiments, the distal portion **1100** includes a proximal spherical or ovoid bulb **1105**, the elongate distal bulb **1110**, and the neck **1115** between the bulbs **1105**, **1110** each having a relatively high braid angle, and segments including the rest of the woven necks have a relatively low braid angle. For example, the lower braid angle segments may have braid angles ranging from about  $0^\circ$  to about  $90^\circ$  (e.g., about  $17^\circ$ , about  $22^\circ$ , about  $45^\circ$ , etc.). Lower braid angle segments generally have lower PPI and tend to have relatively high porosity. Lower PPI can result in a larger pore size, which can allow adequate flow into perforating vessels or small blood vessels adjoining an aneurysm or a vascular malformation such as an arterio-venous fistula, which can maintain flow in these small but important blood vessels. For example, the higher braid angle segment may have braid angles ranging from about  $91^\circ$  to about  $180^\circ$  (e.g., about  $111^\circ$ , about  $112^\circ$ , about  $151^\circ$ , etc.). Higher braid angle segments generally have a higher PPI and tend to have relatively low porosity. Higher PPI can result in a smaller pore size, which can decrease flow into an aneurysm or a vascular malformation such as an arterio-venous fistula, which can aid in thrombosis of the aneurysm or vascular malformation.

[0455] In some embodiments, the outer diameters of the bulbs and necks in the radially-expanded configuration are as follows: the proximal lateral neck **1120** has an outer diameter  $D_1$  configured to be oversized to the large vessel segments such as the common iliac artery (e.g., about 8 mm to about 12 mm); the proximal medial neck **1125** has an outer diameter  $D_2$  configured to be oversized to the large vessel segments such as the common iliac artery (e.g., about 8 mm to about 12 mm); the proximal spherical bulb **1105** has an outer diameter  $D_0$  configured to be oversized by about 20% to about 50% of the largest diameter of abdominal aorta (e.g., about 10 mm to about 40 mm, about 18 mm to about 22 mm); and the distal segment  $D_3$  has an outer diameter configured to be oversized by about 20% to about 50% to the large vessel segments such as the supra-renal or infra-renal abdominal aorta (e.g., about 10 mm to about 40 mm, about 18 mm to about 22 mm). The bulbs **1105**, **1110** the necks **1115**, **1120**, **1125**, and the distal neck **1130** can provide good wall apposition, which can inhibit or prevent the risk of an endo-leak into the aneurysm. The bulbs **1105**, **1110** have substantially uniform dimensions or diameters (e.g., within about  $\pm 5\%$ , about  $\pm 10\%$ , about  $\pm 15\%$ , or about 20% of each other) such that the distal portion **1100** may be considered non-tapered. Although some example diameters are provided herein, some embodiments of the distal portion **1100** may include diameters of the bulbs **1105**, **1110** and necks **1115**, **1120**, **1125**, **1130** in accordance with the values provided above and/or diameters that are within about  $\pm 5\%$ , about  $\pm 10\%$ , about  $\pm 15\%$ , or about  $\pm 20\%$  of any such values.

[0456] Although the necks **1120**, **1125**, **1130** are illustrated in FIG. 7B as being in the same plane (e.g., the plane of the page or the screen), the necks **1120**, **1125**, **1130** may

be in different planes, for example based on certain vasculature. In contrast to endovascular or surgical endoprostheses that require deployment through both common femoral arteries or both common iliac arteries, the example embodiment illustrated in FIG. 7B can be deployed through one artery such as a common femoral artery. Certain distal portions described herein can be described as an endoprosthesis, a stent, etc. A proximal portion can be attached to endoprosthesis through detachable joint (e.g., Guglielmi electrolytic detachment, mechanical detachment, etc.).

[0457] FIG. 7C is a schematic side elevational view of another example embodiment of a distal portion **11400** of a vascular treatment device, for example the distal portion **100** of the device **10**, **20**, **30**, or **40**. The distal portion **11400** includes a plurality of woven bulbs **11405**, **11415**, **11425**, **11435**, a woven neck **11422** between the bulbs **11405**, **11415**, a woven neck **11424** between the bulbs **11415**, **11425**, a woven neck **11426** between the bulbs **11425**, **11435**, a woven proximal neck **11420**, and a woven distal neck **11428**. In some embodiments, the distal portion **11400** includes, in an expanded state, two ovoid or ellipsoid or oblate spheroid outer bulbs **11405**, **11435** and two ovoid or ellipsoid or oblate spheroid inner bulbs **11415**, **11425**, wide-mouthed necks **11422**, **11424**, **11426** between the bulbs **11405**, **11415**, a proximal narrow-mouthed neck **11420** attached to the proximal portion **200** at a joint **300**, and a distal narrow-mouthed neck **11428**. In some embodiments, the bulbs **11405**, **11415**, **11425**, **11435** comprise ellipsoids or oblate spheroids in which the diameter of the polar axis is shorter than the diameter of the equatorial axis (e.g., flattened discs stacked proximate to each other). The necks **11422**, **11424**, **11426** between the bulbs **11405**, **11415**, **11425**, **11435** may be connected at the polar axis rather than being connected at the equatorial axis.

[0458] In some embodiments, the distal portion **11400** includes a plurality of segments, at least one of which has a different braid angle. The distal portion **11400** illustrated in FIG. 7C includes a middle segment comprising the wide-mouthed woven neck **11424** between the two inner bulbs **11415**, **11425**. The middle segment has a relatively low braid angle, and the woven necks **11420**, **11422**, **11426**, **11428** and the woven bulbs **11405**, **11415**, **11425**, **11435** have a relatively high braid angle. In some embodiments, the lower braid angle segment may have braid angles ranging from about  $0^\circ$  to about  $90^\circ$  (e.g., about  $17^\circ$ , about  $22^\circ$ , about  $45^\circ$ , etc.). Lower braid angle segments generally have lower PPI and tend to have relatively high porosity. Lower PPI can result in lower chronic outward force (COF), which can cause flow disruption within a fistula or an abnormal communication between two hollow cavities by forming a soft scaffold within the fistula or abnormal communication between two hollow cavities, which can aid in thrombosis of the fistula or abnormal communication between two hollow cavities. In some embodiments, the higher braid angle segment(s) (e.g., proximal and distal to the lower braid angle segment as illustrated in FIG. 7C) may have braid angles ranging from about  $91^\circ$  to about  $180^\circ$  (e.g., about  $111^\circ$ , about  $112^\circ$ , about  $151^\circ$ , etc.). Higher braid angle segments generally have a higher PPI and tend to have relatively low porosity. Higher PPI can result in a smaller pore size, which can decrease flow into a fistula or abnormal communication between two hollow cavities, which can aid in thrombosis of the fistula or abnormal communication between two hollow cavities. A relatively low pore size can serve as a filter to inhibit or prevent a thrombus

formed within the fistula or abnormal communication between two hollow cavities from forming emboli or small debris that could otherwise break off and enter the normal vasculature. Referring again to FIGS. 4I-4K, the neck **11424** having a high pore size may have a variable length and/or a variable diameter, which can allow the neck **11424** to conform to the dimensions of a fistula or abnormal communication between two hollow cavities, which can provide good wall apposition and/or aid in thrombosis of the fistula or abnormal communication between two hollow cavities. Although some examples of fistulas are provided herein, the distal portion **11400** illustrated in FIG. 7C and the like may be useful in any fistula or abnormal communication between two hollow cavities in the body.

[0459] In some embodiments, the outer diameters of the woven bulbs in the radially-expanded configuration are as follows: the two inner ellipsoid or oblate spheroid bulbs **11415** and **11425** have an outer diameter configured to be oversized between about 50% and about 75% to the width of the orifice of the fistula or abnormal communication between two hollow cavities (e.g., between about 2 mm and about 16 mm, about 8 mm); the two outer ellipsoid or oblate spheroid bulbs **11405** and **11435** have an outer diameter configured to be oversized between about 25% and about 50% to the width of the orifice of the fistula or abnormal communication between two hollow cavities (e.g., between about 2 mm and about 16 mm, about 8 mm); the middle segment neck **11424** has an outer diameter configured to be oversized between about 10% and about 25% to the width of the orifice of the fistula or abnormal communication between two hollow cavities (e.g., between about 2 mm and about 16 mm, about 8 mm); and the middle segment neck **11424** has a length configured to be oversized between about 10% and about 25% to the length of the orifice of the fistula or abnormal communication between two hollow cavities (e.g., between about 2 mm and about 26 mm, between about 4 mm and about 8 mm, about 6 mm). Although some example diameters are provided herein, some embodiments of the distal portion **11400** may include diameters of the woven necks **11420**, **11422**, **11424**, **11426**, **11428**, diameters of the woven bulbs **11405**, **11415**, **11425**, **11435**, and/or length of the woven neck **11424** in accordance with the values provided above and/or diameters that are  $\pm 5\%$ ,  $\pm 10\%$ ,  $\pm 15\%$ , or  $\pm 20\%$  of any such values.

[0460] FIG. 7D is a schematic side elevational view of yet another example embodiment of a distal portion **11600** of a vascular treatment device, for example the distal portion **100** of the device **10**, **20**, **30**, or **40**. The distal portion **11600** includes a plurality of woven bulbs **11610** and woven necks **11620**. In some embodiments, the distal portion **11600** includes, in an expanded state, three ovoid or ellipsoid or spheroid woven bulbs **11610** including a distal bulb **11625**, a middle bulb **11615**, and a proximal bulb **11605**, a wide-mouthed neck **11604** between the bulbs **11625**, **11615**, a wide-mouthed neck **11602** between the bulbs **11615**, **11605**, a proximal narrow-mouthed neck that is attached to the proximal portion at joint **300**, and a distal narrow-mouthed neck **11606**. In some embodiments, the bulbs **11610** are ellipsoids or oblate spheroids having a polar axis diameter that is smaller than an equatorial axis diameter (e.g., flattened discs stacked proximate to each other). The necks **11602**, **11604** between the bulbs **11610** may be connected at the polar axis rather than the equatorial axis. In some embodiments, the distal portion **11600** includes a plurality of segments, at least one of which has a different braid angle. The distal portion

**11600** illustrated in FIG. 7D includes a proximal segment, comprising the proximal bulb **11605**, which is attached to the proximal portion **200** at the joint **300**, that has a relatively high braid angle and a distal segment, comprising the middle bulb **11615**, the distal bulb **11625** and the necks **11602**, **11604**, **11606**, that has a relatively low braid angle. In some embodiments, the lower braid angle segment may have braid angles ranging from about  $0^\circ$  to about  $90^\circ$  (e.g., about  $17^\circ$ , about  $22^\circ$ , about  $45^\circ$ , etc.). Lower braid angle segments generally have lower PPI and tend to have relatively high porosity. Lower PPI can result in a larger pore size, which can cause flow disruption within an aneurysm by forming a soft scaffold within the aneurysm and aid in the thrombosis of the aneurysm. In some embodiments, the higher braid angle segment may have braid angles ranging from about  $91^\circ$  to about  $180^\circ$  (e.g., about  $111^\circ$ , about  $112^\circ$ , about  $151^\circ$ , etc.). Higher braid angle segments generally have a higher PPI and tend to have relatively low porosity. Higher PPI can result in a smaller pore size, which can decrease flow into an aneurysm, which can aid in thrombosis of the aneurysm. A relatively low pore size can serve as a filter to inhibit or prevent a thrombus formed within the aneurysm from breaking off (e.g., as emboli or small debris) and entering the normal vasculature.

[0461] In some embodiments, the outer diameters of the bulbs **11610** in the radially-expanded configuration are as follows: the distal oval or ellipsoid bulb **11625** has an outer diameter configured to be undersized between about 25% to about 50% of the largest diameter of the ventricular wall aneurysm within the heart (e.g., about 5 mm to about 7.5 mm for a ventricular wall aneurysm with the largest diameter about 10 mm); the middle oval or ellipsoid bulb **11615** and the proximal oval or ellipsoid bulb **11605** have an outer diameter configured to be oversized between about 50% to about 75% of the diameter of the neck of the ventricular wall aneurysm such that the proximal bulb **11605** is anchored within the aneurysm with limited risk of the bulb **11605** falling out of the aneurysm into the ventricle of the heart. The proximal oval or ellipsoid bulb **11605** and the middle oval or ellipsoid bulb **11615** may have an outer diameter that is no greater than the largest diameter of the ventricular aneurysm such that there is no or limited significant outward force on the aneurysm wall that could otherwise cause a rupture (e.g., about 7.5 mm to about 8.75 mm for a ventricular wall aneurysm with the largest diameter about 10 mm having a neck with a diameter of about 5 mm). Although some example diameters are provided herein, some embodiments of the distal portion **11600** may include diameters of the bulbs **11625**, **11615**, **11605** in accordance with the values provided above and/or diameters that are within about  $\pm 5\%$ , about  $\pm 10\%$ , about  $\pm 15\%$ , or about  $\pm 20\%$  of any such values, such that the distal portion **11600** may be considered to be tapered.

[0462] FIG. 7E is a schematic side elevational view of still another example embodiment of a distal portion **11500** of a vascular treatment device, for example the distal portion **100** of the device **10**, **20**, **30**, or **40**. The distal portion **11500** includes a plurality of woven bulbs **11510** and woven necks **11520**. In some embodiments, the distal portion **11500** includes, in an expanded state, four ovoid or ellipsoid or spheroid woven bulbs **11510** including a distal bulb **11518**, a second bulb **11516**, a third bulb **11514**, and a proximal bulb **11512**, wide-mouthed necks **11520** between the bulbs **11510**, a proximal narrow-mouthed neck **11522** that is attached to the proximal portion **200** at joint **300**, and a distal narrow-mouthed neck **65**. In some embodiments, the bulbs **11510**

comprise ellipsoids or oblate spheroids having a polar axis diameter that is shorter than an equatorial axis diameter (e.g., flattened discs stacked proximate to each other). The necks **11520** between the bulbs **11510** may be connected at the polar axis rather than the equatorial axis. In some embodiments, the distal portion **11500** includes a plurality of segments, at least one of which has a different braid angle. The distal portion **11500** illustrated in FIG. 7E includes a proximal segment, comprising the proximal two bulbs **11512**, **11514** and the proximal neck **11522**, that has a relatively high braid angle and a distal segment, comprising segments including the rest of the distal portion **11500** including the distal two bulbs **11516**, **11518** and the distal neck **65**, that has a relatively low braid angle. In some embodiments, the lower braid angle segment may have braid angles ranging from about 0° to about 90° (e.g., about 17°, about 22°, about 45°, etc.). Lower braid angle segments generally have lower PPI and tend to have relatively high porosity. Lower PPI can result in a larger pore size, which can cause flow disruption within an aneurysm by forming a soft scaffold within the aneurysm or hollow cavity and can aid in the thrombosis of the aneurysm or hollow cavity. In some embodiments, the higher braid angle segment may have braid angles ranging from about 91° to about 180° (e.g., about 111°, about 112°, about 151°, etc.). Higher braid angle segments generally have a higher PPI and tend to have relatively low porosity. Higher PPI can result in a smaller pore size, which can decrease flow into an aneurysm or hollow cavity, which can aid in thrombosis of the aneurysm or the hollow cavity. A relatively low pore size can serve as a filter to inhibit or prevent a thrombus formed within the aneurysm from breaking off (e.g., as emboli or small debris) and entering the normal vasculature.

**[0463]** In some embodiments, the outer diameters of the bulbs **11510** in the radially-expanded configuration are as follows: the distal ellipsoid or oblate spheroid bulb **11518** has an outer diameter configured to be undersized between about 25% to about 50% to the width of the left atrial appendage within the heart (e.g., between 8 mm to about 35 mm, about 17 mm); the second ellipsoid or oblate spheroid bulb **11516** and the third ellipsoid or oblate spheroid bulb **11514** have an outer diameter configured to be oversized between about 25% to about 50% to the width of the left atrial appendage within the heart (e.g., between 8 mm to about 35 mm, about 17 mm). The proximal ellipsoid or oblate spheroid bulb **11512** has an outer diameter configured to be oversized between about 50% to about 75% to the width of the orifice of the left atrial appendage within the heart (e.g., between 5 mm to about 20 mm, about 10 mm). The length of the distal portion **11500** along the longitudinal axis, illustrated in FIG. 7E with a dashed line, is between 13 mm and about 45 mm (e.g., about 26 mm). Although some example diameters are provided herein, some embodiments of the distal portion **11600** may include diameters of the bulbs **11518**, **11516**, **11514**, **11512** in accordance with the values provided above and/or diameters that are within about ±5%, about ±10%, about ±15%, or about ±20% of any such values, such that the distal portion **11500** may be considered to be tapered.

**[0464]** FIG. 8A is a schematic side perspective view of an example embodiment of a braiding device or carrier braider **150**. The braiding device **150** includes a yarn wheel or braider carrier mechanism or circular horn gear **152** and a plurality of spindles **153** and individual carriers **155**. A spindle **153** is a stick on the circular horn gear **152**. A spool **154** is a hollow device that fits onto a spindle **153** and includes filaments **156**

wound around it. An individual carrier **155** includes a spindle **153** and a spool **154** on the spindle **153**. The terms spindle, spool, and individual carrier may be used interchangeably depending on context. The individual carriers **155** include spools **154** including filaments **156** that are woven together to form the textile structure **158** of the distal portion **100**. The filaments **156** each extend from an individual carrier **155** to a ring or vertical puller **161** over a mandrel **162** and are braided around the mandrel **162** by spinning the circular horn gear **152**, spinning the spindles **153**, and pulling the ring **161** away from the circular horn gear **152**. Although some examples of the carrier braider **150** with 18 spindles **153** or individual carriers **155** are provided herein, some embodiments of the carrier braider **150** may include 6 to 144 spindles **153** or individual carriers **155** in accordance with the values provided above and/or carrier braiders **150** that have 6, 12, 24, 36, 48, 60, 72, 84, 96, 120, 144, etc. spindles **153** or individual carriers **155**. As the textile structure **158** is woven at preform point **160**, the textile structure **158** advances in the direction of the arrow **164**. The circular horn gear **152** spins in the direction of the arrows **166**, and the spindles **153**, which are part of the individual carriers **154**, rotate within the circular horn gear **154** to create the desired braiding pattern.

**[0465]** In some embodiments, the mandrel **162** comprises a rod or tube (e.g., comprising stainless steel) having a uniform outer diameter. In some embodiments, the outer diameter of the mandrel **162** is between about 4 mm and about 9 mm (e.g., about 6 mm, about 6.5 mm). In some embodiments, the outer diameter of the mandrel **162** is between about 33% and about 200% larger than the largest bulb that the distal portion **100** will include. In some embodiments, the smaller the diameters or widths of the filaments, the more oversizing the mandrel **162** may reduce defects at later stages of fabrication.

**[0466]** FIG. 8B is a schematic diagram illustrating an example setup of a braid carrier mechanism **2600**. The yarn wheel **2600** includes spindles **153** without spools **155** or without forming individual carriers **154** and spindles **153** with spools **155** including filaments **156** together forming individual carriers **154**. In FIG. 8B, the half circles with dark shading indicate individual carriers **155** including spools **154** including shape memory filaments, the half circles with hatched shading indicate individual carriers **155** including spools **154** including radiopaque filaments, and the half circles with no shading indicate spindles without spools **154** or filaments **156**. The yarn wheel **2600** illustrated in FIG. 8B includes 144 spindles **153** or individual carriers **154** with 72 outer spindles labeled 1o through 72o and 72 inner spindles labeled 1i through 72i. One outer spindle and one inner spindle form a “double spindle pair.” The spindles **154** spin in the direction indicated by the arrow proximate to the shading. In the arrangement illustrated in FIG. 8B, spindles 1o, 2i, 4o, 5i, 7o, 8i, 10o, 11i, 13o, 14i, 16o, 17i, 19o, 20i, 22o, 23i, 25o, 26i, 28o, 29i, 31o, 32i, 34o, 35i, 37o, 38i, 40o, 41i, 43o, 44i, 46o, 47i, 49o, 50i, 52o, 53i, 55o, 56i, 58o, 59i, 61o, 62i, 64o, 65i, 67o, 68i, 70o, and 71i include spools including shape-memory material (e.g., 48 of the filaments **156** comprise shape-memory material) and the remaining spindles are empty. None of the spindles includes radiopaque material.

**[0467]** Certain patterns can be discerned based on spindle arrangement and spin direction. For example, in the braid carrier mechanism **2600** of FIG. 8B, spindles 1o and 2i spin in opposite directions such that during weaving, filaments extending from the spools **154** on the spindles 1o and 2i will cross over each other, spindles 2i and 4o spin in the same

direction such that during weaving, filaments extending from the spools **154** on the spindles **2i** and **4o** cross under each other, and spindles **4o** and **5i** spin in opposite directions such that during weaving, filaments extending from the spools **154** on the spindles **4o** and **5i** cross over each other, such that a one-over-one-under-one braiding pattern for the shape memory filaments can be discerned by analysis of the braid carrier mechanism **2600** of FIG. **8B**.

[**0468**] FIG. **8C** is a schematic diagram illustrating a magnified view of three pairs of spindles **1o**, **1i**, **2o**, **2i**, **3o**, **3i** in the example setup of the braid carrier mechanism **2600** of FIG. **8B**. In FIGS. **8B** and **8C**, the pattern of the filaments **156** is symmetrical because there is a spool **154** including a shape memory filament in the outer spindle **1o** paired with an empty inner spindle **1i**, followed by an empty outer spindle **2o** paired with a spool **154** including a shape memory filament in the inner spindle **2i**, and then followed by an empty double spindle pair **3o**, **3i**, and then the pattern repeats itself in the pairs of spindles **4o**, **4i**, **5o**, **5i**, **6o**, **6i** and so on. Symmetrical patterns of filaments **156** may be associated with a uniform pore size. Filament adjacency may be defined as the angular circumference of the yarn wheel **152**, which is  $360^\circ$ , divided by the number of filament spools. For example, if the yarn wheel **152** includes 48 filament spools, the filament adjacency would be  $360^\circ/48=7.5^\circ$ . Filament adjacency may be used, for example, to help control symmetry of patterns. In some embodiments, the pattern of spools including the filaments **156** on spindles **153** can be asymmetrical, which can lead to varying pore size along the braid axis.

[**0469**] In some embodiments, placement of spools **154** or lack of placement of spools **154** including filaments **156** on spindles **153** adjacent to each other can affect properties of the textile structure **158** such as pore size. Spindle adjacency may be defined as the angular circumference of the yarn wheel **152**, which is  $360^\circ$ , divided by the number of double spindle pairs. For example, if the yarn wheel **152** includes 144 spindles **153** or 72 double spindle pairs, the spindle adjacency would be  $360^\circ/72=5^\circ$ . In some embodiments, each double spindle pair that is empty creates a pore. Increasing the number of empty spindles **154** adjacent to each other (e.g., one, two, or more spindle pairs adjacent to each other) may increase the size of the pore. FIG. **8D** is a photograph illustrating a plurality of filaments **156** being braided on a mandrel **162** using a braiding device or carrier braider **150**. In FIG. **8D**, the reflectivity of the radiopaque filaments **156** contrast with the reflectivity of the shape-memory filaments **156**, creating a crisscross appearance of the tubular textile structure **158**. In some embodiments, the placement of spools **154** including filaments **156** of a particular type of material on spindles **153** adjacent to each other can affect properties such as visibility under x-ray. Filament material adjacency may be defined as the angular circumference of the yarn wheel **152**, which is  $360^\circ$ , divided by the number of filament spools of a particular type of material. For example, if the yarn wheel **152** includes 12 filament spools including radiopaque filaments evenly spaced from each other, the filament material adjacency would be  $360^\circ/12=30^\circ$ . Filament material adjacency may be used to help control helical crossing points that are visible under x-ray. The arrangement of the filaments **156** illustrated in FIG. **8B**, in which some radiopaque filaments **156** are circumferentially adjacent or proximate to each other, groups some radiopaque filaments to form an intertwining band of radiopaque material. A band of radiopaque material, for

example as opposed to evenly distributed radiopaque material, may be easier to identify during fluoroscopy, particularly if the filaments are small.

[**0470**] In some embodiments, the radiopaque material includes metals or alloys including, but not limited to, iridium, platinum, tantalum, gold, palladium, tungsten, tin, silver, titanium, nickel, zirconium, rhenium, bismuth, molybdenum, combinations thereof, and the like, which can increase visibility of the distal portion **100** under fluoroscopy during interventional procedures. The radiopaque material may be part of an alloy (e.g., 92% platinum and 8% tungsten alloy), part of a core or cladding around a core (e.g., nitinol with a tungsten core), combinations thereof, and the like.

[**0471**] FIG. **8E** is a schematic side elevational view of still another example embodiment of a distal portion **2800** of a vascular treatment device, for example the distal portion **100** of the device **10**, **20**, **30**, or **40**. The distal portion **2800** includes, in an expanded state, a proximal neck **70** and a cylindrical wide-mouthed textile structure **75** including shape-memory filaments and radiopaque filaments. The textile structure **75** expands radially outwardly from proximal to distal, and then stays at the larger diameter until the distal end. FIG. **8F** is a schematic side elevational view of the distal portion **2800** of FIG. **8E**, illustrating an example pattern of radiopaque filaments, for example under x-ray. The distal portion **2800** includes, in an expanded state, a single radiopaque filament **2820** that is interlaced in the form a single sine wave that appears like a "simple helix" at least under x-ray. The pattern of radiopacity can allow an operator of a device comprising the distal portion **2800** to visualize and identify the distal portion **2800** at least under x-ray. In some embodiments, the single simple helix includes troughs and peaks, for example at the sides of the distal portion **2800** that the simple helix at least partially creates. In FIG. **8F**, the helical intersection points **2825**, **2835**, **2845**, **2855** are substantially uniformly spaced by distances **2830**, **2840**, **2850**, which can allow the distal portion **2800** to serve as an angiographic measurement ruler. For example, the distances **2830**, **2840**, **2850** can help an operator to measure the length of blood clots, the neck of an aneurysm, the length of a stenosis, etc. In some embodiments, a distance **2860** between points **2855**, **2856** at least partially along the proximal neck **70** has different dimensions than the simple helix in the rest of the larger diameter part of the distal portion **2800**, which may serve as an identifier of the proximal neck **70** beyond which the distal portion **2800** should not be deployed.

[**0472**] FIG. **8G** is a schematic diagram illustrating an example setup of a braid carrier mechanism **2870** for forming the distal portion **2800** of FIG. **8E**. In FIG. **8G**, the half circles with dark shading indicate individual carriers **155** including spools **154** including shape memory filaments **156**, the half circles with hatched shading indicate individual carriers **155** including spools **154** including radiopaque filaments **156**, and the half circles with no shading indicate spindles without spools **154** or filaments **156**. In the arrangement illustrated in FIG. **8G**, spindles **2i**, **4o**, **5i**, **7o**, **8i**, **10o**, **11i**, **13o**, **14i**, **16o**, **17i**, **19o**, **20i**, **22o**, **23i**, **25o**, **26i**, **28o**, **29i**, **31o**, **32i**, **34o**, **35i**, **37o**, **38i**, **40o**, **41i**, **43o**, **44i**, **46o**, **47i**, **49o**, **50i**, **52o**, **53i**, **55o**, **56i**, **58o**, **59i**, **61o**, **62i**, **64o**, **65i**, **67o**, **68i**, **70o**, **71i** include spools **154** including shape-memory material (e.g., **47** of the filaments **156** comprise shape-memory material), the spindle **1o** includes a spool including radiopaque material (e.g., **1** of the 48 filaments **156** comprises radiopaque material), and the remaining spindles **153** are empty. The braid carrier mecha-

nism **2870** setup illustrated in FIG. **8G** can generate a pattern of radiopacity described with respect to FIG. **8F**, for example a single sine wave or simple helix pattern. The radiopaque filament **156** forms a sine wave having a spindle adjacency of about  $5^\circ$  ( $360^\circ/72$ ), a filament adjacency of about  $7.5^\circ$  ( $360^\circ/48$ ), and a radiopaque filament material adjacency of about  $360^\circ$  ( $360^\circ/1$ ). Although some examples of the carrier braider **150** with 48 spindles **153** or individual carriers **155** are provided herein, some embodiments of the carrier braider **150** may include 6 to 144 spindles **153** or individual carriers **155** in accordance with the values provided above and/or carrier braiders **150** that have 6, 12, 24, 36, 48, 60, 72, 84, 96, 120, 144, etc. spindles **153** or individual carriers **155**, and the number and positioning of radiopaque filaments **156** can remain as provided in the example braid carrier mechanism **2870** setup.

[0473] FIG. **8H** is a schematic side elevational view of another example embodiment of a distal portion **2900** of a vascular treatment device illustrating an example pattern of radiopaque filaments, for example under x-ray. The distal portion **2900** may be the distal portion **100** of the device **10**, **20**, **30**, or **40**. The distal portion **2900** includes, in an expanded state, a proximal neck **70** and a cylindrical wide-mouthed textile structure **75** including shape-memory filaments and radiopaque filaments. The textile structure **75** expands radially outwardly from proximal to distal, and then stays at the larger diameter until the distal end. The distal portion **2900** includes, in an expanded state, two radiopaque filaments **2911**, **2913** that are interlaced in the form a double sine wave like a “double helix” at least under x-ray. The pattern of radiopacity can allow an operator of a device comprising the distal portion **2900** to visualize and identify the distal portion **2900** at least under x-ray. In some embodiments, the double helix includes troughs and peaks, for example at the sides of the distal portion **2900** that the double helix at least partially create. In FIG. **8H**, the helical intersection points **2925**, **2935**, **2945**, **2955**, **2965**, **2975** are substantially uniformly spaced by distances **2930**, **2940**, **2950**, **2960**, **2970**, **2980**, which can allow the distal portion **2900** to serve as an angiographic measurement ruler. For example, the distances **2930**, **2940**, **2950**, **2960**, **2970**, **2980** can help an operator to measure the length of blood clots, the neck of an aneurysm, the length of a stenosis, etc. In some embodiments, distances between helical intersection points in the proximal neck **70** has different dimensions than the double helix in the rest of the large diameter part of the distal portion **2900**, which may serve as an identifier of the proximal neck **70** beyond which the distal portion **2900** should not be deployed.

[0474] FIG. **8I** is a schematic diagram illustrating an example setup of a braid carrier mechanism **2990** for forming the distal portion **2800** of FIG. **8H**. In FIG. **8I**, the half circles with dark shading indicate individual carriers **155** including spools **154** including shape memory filaments **156**, the half circles with hatched shading indicate individual carriers **155** including spools **154** including radiopaque filaments **156**, and the half circles with no shading indicate spindles without spools **154** or filaments **156**. In the arrangement illustrated in FIG. **8I**, spindles **2i**, **4o**, **5i**, **7o**, **8i**, **10o**, **11i**, **13o**, **14i**, **16o**, **17i**, **19o**, **20i**, **22o**, **23i**, **25o**, **26i**, **28o**, **29i**, **31o**, **32i**, **34o**, **35i**, **38i**, **40o**, **41i**, **43o**, **44i**, **46o**, **47i**, **49o**, **50i**, **52o**, **53i**, **55o**, **56i**, **58o**, **59i**, **61o**, **62i**, **64o**, **65i**, **67o**, **68i**, **70o**, **71i** include spools **154** including shape-memory material (e.g., 46 of the 48 filaments **156** comprise shape-memory material), the spindles **1o** and **37o** include spools **154** including radiopaque material (e.g., 2

of the 48 filaments **156** comprise radiopaque material), and the remaining spindles are empty. The braid carrier mechanism **2990** setup illustrated in FIG. **8I** can generate a pattern of radiopacity described with respect to FIG. **8H**, for example a double sine wave or double helix pattern. The radiopaque filaments **156** form two sine waves having a spindle adjacency of about  $5^\circ$  ( $360^\circ/72$ ), a filament adjacency of about  $7.5^\circ$  ( $360^\circ/48$ ), and a radiopaque filament material adjacency of about  $180^\circ$  ( $360^\circ/2$ ). Although some examples of the carrier braider **150** with 48 spindles **153** or individual carriers **155** are provided herein, some embodiments of the carrier braider **150** may include 6 to 144 spindles **153** or individual carriers **155** in accordance with the values provided above and/or carrier braiders **150** that have 6, 12, 24, 36, 48, 60, 72, 84, 96, 120, 144, etc. spindles **153** or individual carriers **155**, and the number and positioning of radiopaque filaments **156** can remain as provided in the example braid carrier mechanism **2990** setup.

[0475] FIG. **8J** is a schematic side elevational view of yet another example embodiment of a distal portion **4000** of a vascular treatment device illustrating an example pattern of radiopaque filaments, for example under x-ray. The distal portion **4000** may be the distal portion **100** of the device **10**, **20**, **30**, or **40**. The distal portion **4000** includes, in an expanded state, a proximal neck **70** and a cylindrical wide-mouthed textile structure **75** including shape-memory filaments and radiopaque filaments. The textile structure **75** expands radially outwardly from proximal to distal, and then stays at the larger diameter until the distal end. The distal portion **4000** includes, in an expanded state, two pairs of radiopaque filaments **4011**, **4013** and **4015**, **1017** that are interlaced in the form a paired double sine wave like a “dual double helix” at least under x-ray. The pattern of radiopacity can allow an operator of a device comprising the distal portion **4000** to visualize and identify the distal portion **4000** at least under x-ray. In some embodiments, the dual double helix includes troughs and peaks, for example at the sides of the distal portion **4000** that the dual double helix at least partially create. In FIG. **8J**, the helical intersection points **4025**, **4035**, **4045**, **4055** are substantially uniformly spaced by distances **4030**, **4040**, **4050**, which can allow the distal portion **4000** to serve as an angiographic measurement ruler. For example, the distances **4030**, **4040**, **4050** can help an operator to measure the length of blood clots, the neck of an aneurysm, the length of a stenosis, etc. In some embodiments, a distance **4060** between points **4055**, **4065** at least partially along the proximal neck **70** has different dimensions than the dual double helix in the rest of the large diameter part of the distal portion **4000**, which may serve as an identifier of the proximal neck **70** beyond which the distal portion **4000** should not be deployed.

[0476] FIG. **8K** is a schematic diagram illustrating an example setup of a braid carrier mechanism **4080** for forming the distal portion **4000** of FIG. **8J**. In FIG. **8K**, the half circles with dark shading indicate individual carriers **155** including spools **154** including shape memory filaments **156**, the half circles with hatched shading indicate individual carriers **155** including spools **154** including radiopaque filaments **156**, and the half circles with no shading indicate spindles without spools **154** or filaments **156**. In the arrangement illustrated in FIG. **8K**, spindles **2i**, **4o**, **5i**, **7o**, **8i**, **10o**, **11i**, **13o**, **14i**, **16o**, **17i**, **19o**, **20i**, **22o**, **23i**, **25o**, **26i**, **28o**, **29i**, **31o**, **32i**, **34o**, **38i**, **40o**, **41i**, **43o**, **44i**, **46o**, **47i**, **49o**, **50i**, **52o**, **53i**, **55o**, **56i**, **58o**, **59i**, **61o**, **62i**, **64o**, **65i**, **67o**, **68i**, **70o** include spools **154** including

shape-memory material (e.g., 44 of the 48 filaments **156** comprise shape-memory material), the spindles **1o**, **35i**, **37o**, **71i** include spools **154** including radiopaque material (e.g., 4 of the 48 filaments **156** comprise radiopaque material), and the remaining spindles are empty. The braid carrier mechanism **4080** setup illustrated in FIG. **8K** can generate a pattern of radiopacity described with respect to FIG. **8J**, for example pairs of double sine waves or a dual double helix pattern. Although some examples of the carrier braider **150** with 48 spindles **153** or individual carriers **155** are provided herein, some embodiments of the carrier braider **150** may include 6 to 144 spindles **153** or individual carriers **155** in accordance with the values provided above and/or carrier braiders **150** that have 6, 12, 24, 36, 48, 60, 72, 84, 96, 120, 144, etc. spindles **153** or individual carriers **155**, and the number and positioning of radiopaque filaments can remain as provided in the example braid carrier mechanism **4080** setup.

[0477] FIG. **8L** is an x-ray photograph illustrating an example of a plurality of radiopaque filaments of the distal portion **4000** of FIG. **8J**, in which the radiopaque filaments **4011**, **4013**, **4015**, **4017** form a dual double helix or four sine waves, pairs of which are offset by about  $180^\circ$  and the sine waves in each pair being offset from each other by about  $7.5^\circ$ . In some embodiments, crossings of the radiopaque filaments **4011**, **4013**, **4015**, **4017** of the distal portion **4000** can be used as a rough measurement guide. For example, in FIG. **8L**, the spacing between helical intersections points is about 2 mm, which can help serve as an angiographic measurement ruler. For example, the distal portion **4000** can help measure the length of blood clots, the neck of an aneurysm, the length of a stenosis, etc.

[0478] FIG. **8M** is a schematic side elevational view of still another example embodiment of a distal portion **4100** of a vascular treatment device illustrating an example pattern of radiopaque filaments, for example under x-ray. The distal portion **4100** may be the distal portion **100** of the device **10**, **20**, **30**, or **40**. The distal portion **4100** includes, in an expanded state, a proximal neck **70** and a cylindrical wide-mouthed textile structure **75** including shape-memory filaments and radiopaque filaments. The textile structure **75** expands radially outwardly from proximal to distal, and then stays at the larger diameter until the distal end. The distal portion **4100** includes, in an expanded state, two trios of radiopaque filaments **4111**, **4113**, **4115** and **4117**, **4119**, **4121** that are interlaced in the form a paired triple sine wave like a “reinforced double helix” at least under x-ray. The pattern of radiopacity can allow an operator of a device comprising the distal portion **4100** to visualize and identify the distal portion **4100** at least under x-ray. In some embodiments, the reinforced double helix includes troughs and peaks, for example at the sides of the distal portion **4100** that the reinforced double helix at least partially creates. In FIG. **8M**, the intersection points **4125**, **4135**, **4145** along the reinforced double helix are substantially uniformly spaced by distances **4130**, **4140**, **4150**, which can allow the distal portion **4100** to serve as an angiographic measurement ruler. For example, the distances **4130**, **4140**, **4150** can help an operator to measure the length of blood clots, the neck of an aneurysm, the length of a stenosis, etc. In some embodiments, a distance **4160** between points **4155**, **4165** at least partially along the proximal neck **70** has different dimensions than the reinforced double helix in the rest of the large diameter part of the distal portion **4100**, which may serve as an identifier of the proximal neck **70** beyond which the distal portion **4100** should not be deployed.

[0479] FIG. **8N** is a schematic diagram illustrating an example setup of a braid carrier mechanism **4180** for forming the distal portion **4100** of FIG. **8M**. In FIG. **8N**, the half circles with dark shading indicate individual carriers **155** including spools **154** including shape memory filaments **156**, the half circles with hatched shading indicate individual carriers **155** including spools **154** including radiopaque filaments **156**, and the half circles with no shading indicate spindles without spools **154** or filaments **156**. In the arrangement illustrated in FIG. **8N**, spindles **4o**, **5i**, **7o**, **8i**, **10o**, **11i**, **13o**, **14i**, **16o**, **17i**, **19o**, **20i**, **22o**, **23i**, **25o**, **26i**, **28o**, **29i**, **31o**, **32i**, **34o**, **40o**, **41i**, **43o**, **44i**, **46o**, **47i**, **49o**, **50i**, **52o**, **53i**, **55o**, **56i**, **58o**, **59i**, **61o**, **62i**, **64o**, **65i**, **67o**, **68i**, **70o** include spools **154** including shape-memory material (e.g., 42 of the 48 filaments **156** comprise shape-memory material), the spindles **1o**, **3i**, **35i**, **37o**, **39i**, **71i** include spools **154** including radiopaque material (e.g., 6 of the 48 filaments **156** comprise radiopaque material), and the remaining spindles are empty. The braid carrier mechanism **4180** setup illustrated in FIG. **8N** can generate a pattern of radiopacity described with respect to FIG. **8M**, for example pairs of triple sine waves or a reinforced double helix pattern. Although some examples of the carrier braider **150** with 48 spindles **153** or individual carriers **155** are provided herein, some embodiments of the carrier braider **150** may include 6 to 144 spindles **153** or individual carriers **155** in accordance with the values provided above and/or carrier braiders **150** that have 6, 12, 24, 36, 48, 60, 72, 84, 96, 120, 144, etc. spindles **153** or individual carriers **155**, and the number and positioning of the radiopaque filaments can remain as provided in the example braid carrier mechanism **4180** setup.

[0480] FIG. **8O** is a photograph illustrating a plurality of radiopaque filaments of the distal portion **4100** of FIG. **8M**. The distal portion **4100** includes a plurality of shape-memory filaments and a plurality of radiopaque filaments over a mandrel, in which the radiopaque filaments form a reinforced double helix or in which the radiopaque filaments form pairs of sine waves trios, one of which includes the radiopaque filaments **4111**, **4113**, **4115**. The trios are offset by about  $180^\circ$  and the sine waves in each trio are offset from each other by about  $7.5^\circ$ . In some embodiments, crossings of the radiopaque filaments of the distal portion **4100** can be used as a rough measurement guide. For example, in FIG. **8O**, the spacing between the crossings of the helical intersections points is about 2 mm, which can help serve as an angiographic measurement ruler. For example, the distal portion **4100** can help measure the length of blood clots, the neck of an aneurysm, the length of a stenosis, etc.

[0481] FIG. **8P** is a schematic side elevational view of yet still another example embodiment of a distal portion **4200** of a vascular treatment device, for example of the distal portion **100** of the device **10**, **20**, **30**, or **40**. The distal portion **4200** includes, in an expanded state, a proximal neck **70** and a cylindrical wide-mouthed textile structure **75** including shape-memory filaments and radiopaque filaments. The textile structure **75** expands radially outwardly from proximal to distal, and then stays at the larger diameter until the distal end. The distal portion **4200** includes three radiopaque filaments **4211**, **4212**, **4213** that form a three sine waves like a “three phase helix” at least under x-ray. FIG. **8Q** is a magnified view of the radiopaque filaments **4211**, **4212**, **4213** of the distal portion **4200** of FIG. **8P**, for example under x-ray. FIG. **8Q** illustrates the filament **4211** as a solid line, the filament **4212** as a dashed line, and the filament **4213** as a dash-dot-dot line

for easier differentiation between the filaments **4211**, **4212**, **4213**. In some embodiments, the first radiopaque filament **4211** forms a sine wave having a phase A, the second radiopaque filament **4212** forms a sine wave having a phase B, and the third radiopaque filament **4213** forms a sine wave having a phase C. In some embodiments, the three phase helix includes troughs and peaks, for example at the sides of the distal portion **4200** that the three sine waves at least partially create.

**[0482]** The distance between two similarly situated points on a sine wave (e.g., a first intersection of a sine wave and the central longitudinal axis of the distal portion and the next intersection of the sine wave with the central longitudinal axis after forming a peak and a trough, the distance between a first peak of a sine wave and the next peak of the sine wave, the distance between a first trough of the sine wave and the next trough of the sine wave, etc.) is called the pitch or period or wavelength or cycle of the sine wave. Embodiments comprising a three phase sine wave include three pitches: the sine wave formed by the radiopaque filament **4211** has a pitch **4221**, the sine wave formed by the radiopaque filament **4212** has a pitch **4222**, and the sine wave formed by the radiopaque filament **4213** has a pitch **4223**. FIG. **8P** shows the pitches **4221**, **4222**, **4223** as the distances between the lower peaks of the respective sine waves, and FIG. **8Q** shows the pitches **4221**, **4222** as the distances between the upper peaks of the respective sine waves. In the embodiments illustrated in FIGS. **8P** and **8Q**, the pitches of the sine waves formed by the radiopaque filaments **4211**, **4212**, **4213** have substantially uniform dimensions (e.g., pitches), except near the proximal neck **70**, although the sine waves may have differing dimensions (e.g., pitches).

**[0483]** In some embodiments, the distance between each trough or peak of a radiopaque filament **4211**, **4212**, **4213** with another trough or peak of an adjacent radiopaque filament of the three phase helix is called a phase shift. In FIG. **8P**, phase A is offset from phase B by about  $7.5^\circ$  (shown by the distance **4231**), phase B is offset from phase C by about  $7.5^\circ$  (shown by the distance **4232**), and phase A is offset from phase C by about  $15^\circ$  (shown by the distance **4233**). FIG. **8P** shows the phase shifts **4231**, **4232**, **4233** as the distances between the upper peaks of the respective sine waves, and FIG. **8Q** shows the phase shifts **4231**, **4232**, **4233** as the distances between the centers following upper peaks of the respective sine waves. The pattern of radiopacity can allow an operator of a device comprising the distal portion **4200** to visualize and identify the distal portion **4200** at least under x-ray. In FIGS. **8P** and **8Q**, the intersection points along the three phase helix are substantially uniformly spaced by distances **4241** or multiples thereof (e.g., the distance **4243** is the distance between three intersection points, the distance **4242** in FIG. **8S** is the distance between two intersection points, etc.), which can allow the distal portion **4200** to serve as an angiographic measurement ruler. For example, the distances **4241**, **4242**, **4243** can help an operator to measure the length of blood clots, the neck of an aneurysm, the length of a stenosis, etc. In some embodiments, distances between intersection points at least partially along the three phase helix near the proximal neck **70** have different dimensions than the three phase helix in the rest of the large diameter portion of the distal portion **4200**, which may serve as an identifier of the proximal neck **70** beyond which the distal portion **4200** should not be deployed.

**[0484]** FIG. **8R** is a schematic diagram illustrating an example setup of a braid carrier mechanism **4280** for the distal portion **4200** of FIG. **8P**. In FIG. **8R**, the half circles with dark shading indicate individual carriers **155** including spools **154** including shape memory filaments **156**, the half circles with hatched shading indicate individual carriers **155** including spools **154** including radiopaque filaments **156**, and the half circles with no shading indicate spindles without spools **154** or filaments **156**. In the arrangement illustrated in FIG. **8R**, spindles **2i**, **4o**, **5i**, **7o**, **8i**, **10o**, **11i**, **13o**, **14i**, **16o**, **17i**, **19o**, **20i**, **22o**, **23i**, **26i**, **28o**, **29i**, **31o**, **32i**, **34o**, **35i**, **37o**, **40o**, **41i**, **43o**, **44i**, **46o**, **47i**, **50i**, **52o**, **53i**, **55o**, **56i**, **58o**, **59i**, **61o**, **62i**, **64o**, **65i**, **67o**, **68i**, **70o**, **71i** include spools **154** including shape-memory material (e.g., **45** of the **48** filaments **156** comprise shape-memory material), the spindles **1o**, **25o**, **49o** include spools **154** including radiopaque material (e.g., **3** of the **48** filaments **156** comprise radiopaque material), and the remaining spindles are empty. The braid carrier mechanism **4280** setup illustrated in FIG. **8Q** can generate a pattern of radiopacity described with respect to FIG. **8P**, for example a three phase-shifted sine waves or a three phase helix pattern. Although some examples of the carrier braider **150** with **48** spindles **153** or individual carriers **155** are provided herein, some embodiments of the carrier braider **150** may include **6** to **144** spindles **153** or individual carriers **155** in accordance with the values provided above and/or carrier braiders **150** that have **6**, **12**, **24**, **36**, **48**, **60**, **72**, **84**, **96**, **120**, **144**, etc. spindles **153** or individual carriers **155**, and the number and positioning of the radiopaque filaments can remain as provided in the example braid carrier mechanism **4280** setup.

**[0485]** FIG. **8S** is an x-ray photograph illustrating an example of a plurality of radiopaque filaments **4211**, **4212**, **4213** of the distal portion **4200** of FIG. **8P**, in which the radiopaque filaments **4211**, **4212**, **4213** form a three phase helix, or in which the radiopaque filaments form three sine waves offset by about  $120^\circ$ . In some embodiments, crossings or intersection points of the radiopaque filaments **4211**, **4212**, **4213** of the distal portion **4200** can be used as a rough measurement guide. For example, in FIG. **8S**, the distance **4242** between the three intersections points is about **1 mm**, which can allow the distal portion **4200** to serve as an angiographic measurement ruler. For example, the distance **4242** can an operator to measure the length of blood clots, the neck of an aneurysm, the length of a stenosis, etc. Use of other distances are also possible (e.g., a distance **4241** between two intersection points (e.g., as shown in FIG. **8P**), a distance **4243** between four intersection points (e.g., as shown in FIG. **8P**), distances between similar portions of one or more sine waves (e.g., peaks, troughs, etc.), etc.).

**[0486]** FIG. **8T-1** is a schematic side elevational view of still yet another example embodiment of a distal portion **4300** of a vascular treatment device illustrating an example pattern of radiopaque filaments, for example under x-ray. The distal portion **4300** may be the distal portion **100** of the device **10**, **20**, **30**, or **40**. The distal portion **4300** includes, in an expanded state, a proximal neck **70** and a cylindrical wide-mouthed textile structure including shape-memory filaments and radiopaque filaments. The textile structure **75** expands radially outwardly from proximal to distal, and then stays at the larger diameter until the distal end.

**[0487]** FIG. **8T-2** is a schematic side elevational view of another example embodiment of the distal portion **4370** of a vascular treatment device illustrating an example pattern of radiopaque filaments **4311**, **4312**, **4313**, for example under



x-ray. The distal portion **4370** may be the distal portion **100** of the device **10**, **20**, **30**, or **40**. In FIG. **8T-2**, the distal portion **4370** comprises a plurality of woven bulbs, woven necks, a proximal neck **70**, and a distal neck tip **65**, for example similar to the distal portion **1100** of FIG. **2B**.

[**0488**] The distal portions **4300**, **4370** include, in an expanded state, radiopaque filaments **4311**, **4312**, **4313** that are interlaced in the form a three phase helix at least under x-ray. One or more of the filaments **4311**, **4312**, **4313** may be reinforced (e.g., the filament **4311**) with a second radiopaque filament and the distal portions **4300**, **4370** may include additional radiopaque filaments that are non-reinforced (e.g., the filaments **4312**, **4313**), for example as described herein with respect to FIG. **8T-3**. The pattern of radiopacity can allow an operator of a device comprising the distal portion **4300**, **4370** to visualize identify the distal portion **4300**, **4370** at least under x-ray. In some embodiments, the three phase helix includes troughs and peaks, for example at the sides of the distal portion **4300**, **4370** that the paired three phase helix at least partially create. In FIGS. **8T-1** and **8T-2**, the intersection points along the triple helix are substantially uniformly spaced, which can allow the distal portion **4300**, **4370** to serve as an angiographic measurement ruler. For example, the distances between intersections can help an operator to measure the length of blood clots, the neck of an aneurysm, the length of a stenosis, etc. In some embodiments, a distance at least partially along the proximal neck **70**, along the distal neck **65**, and/or along the bulbs has different dimensions than paired triple helix in the rest of the distal portion **4300**, which may serve as an identifier of the proximal neck **70**, the distal neck **65**, and/or the bulbs, for example beyond which the distal portion **4300**, **4370** should not be deployed.

[**0489**] FIG. **8T-3** is a schematic diagram illustrating an example setup of a braid carrier mechanism **4380** for the distal portions **4300**, **4370** of FIGS. **8T-1** and **8T-2**. In FIG. **8T-3**, the half circles with dark shading indicate individual carriers **155** including spools **154** including shape memory filaments **156**, the half circles with hatched shading indicate individual carriers **155** including spools **154** including radiopaque filaments **156**, and the half circles with no shading indicate spindles without spools **154** or filaments **156**. In the arrangement illustrated in FIG. **8T-3**, spindles 4o, 5i, 7o, 8i, 10o, 11i, 14i, 16o, 17i, 19o, 20i, 22o, 23i, 28o, 29i, 31o, 32i, 34o, 35i, 40o, 41i, 43o, 44i, 46o, 47i, 52o, 53i, 55o, 56i, 58o, 59i, 62i, 64o, 65i, 67o, 68i, 70o, 71i include spools **154** including shape-memory material (e.g., 39 of the 48 filaments **156** comprise shape-memory material), the spindles 1o, 2i, 13o, 25o, 26, 37o, 49o, 50i/61o include spools **154** including radiopaque material (e.g., 9 of the 48 filaments **156** comprise radiopaque material), and the remaining spindles are empty. The braid carrier mechanism **4380** setup illustrated in FIG. **8T-3** can generate a pattern of radiopacity described with respect to FIGS. **8T-1** and **8T-2**, for example a reinforced three phase helix (including a sine wave formed by each radiopaque filament pairs 1o/2i, 25o/26i, 49o/50i) and a non-reinforced three phase helix (including a sine wave formed by each single radiopaque filament 13o, 37o, 61o) or a reinforced three phase helix. Although some examples of the carrier braider **150** with 48 spindles **153** or individual carriers **155** are provided herein, some embodiments of the carrier braider **150** may include 6 to 144 spindles **153** or individual carriers **155** in accordance with the values provided above and/or carrier braiders **150** that have 6, 12, 24, 36, 48, 60, 72, 84, 96, 120, 144, etc. spindles **153** or individual carriers **155**

and the number and positioning of the radiopaque filaments can remain as provided in the example braid carrier mechanism **4380** setup. Different weights are also possible. For example, a reinforced three phase helix may include three or more radiopaque filaments per phase. For another example, a non-reinforced three phase helix may include more than one radiopaque filament per phase, for example as long as the reinforced three phase helix in that paired three phase helix includes more filaments per wave such that the latter is relatively reinforced.

[**0490**] FIG. **8T-4** is an x-ray photograph illustrating an example of a plurality of radiopaque filaments of the distal portion **4370** of FIG. **8T-2**. The distal portion **4370** includes a proximal neck **70** and a distal neck **65**, and includes a plurality of radiopaque filaments in which the radiopaque filaments form a reinforced three phase helix. In some embodiments, crossings of the radiopaque filaments **4311**, **4312**, **4313**, **4314**, **4315** of the distal portion **4370** can serve as an angiographic measurement ruler. For example, the distances between the crossings can help an operator of a device comprising the distal portion **4370** to measure the length of blood clots, the neck of an aneurysm, the length of a stenosis, etc. Other features can also be used. For example, in FIG. **8T-4**, the width of a bulb measurable due to the paired triple helix is about 2 mm.

[**0491**] FIG. **8U** is a schematic side elevational view of another example embodiment of a distal portion **4390** of a vascular treatment device illustrating an example pattern of radiopaque filaments, for example under x-ray. The distal portion **4390** may be the distal portion **100** of the device **10**, **20**, **30**, or **40**. The distal portion **4390** includes, in an expanded state, a proximal neck **70** and a cylindrical wide-mouthed textile structure including shape-memory filaments and radiopaque filaments. The textile structure **75** expands radially outwardly from proximal to distal, and then stays at the larger diameter until the distal end.

[**0492**] The distal portion **4390** includes, in an expanded state, radiopaque filaments **4311**, **4312**, **4313** that are interlaced in the form a paired three phase helix at least under x-ray. The filaments **4311**, **4312**, **4313** may be reinforced with a second radiopaque filament and additional the distal portions **4390** may include additional radiopaque filaments that are non-reinforced. The pattern of radiopacity can allow an operator of a device comprising the distal portion **4390** to visualize identify the distal portion **4390** at least under x-ray. In some embodiments, the paired three phase helix includes troughs and peaks, for example at the sides of the distal portion **4390** that the paired three phase helix at least partially creates. A paired three phase helix includes a pitch for each reinforced filament (e.g., a pitch **4321** for the sine wave created by the filaments **4311**, a pitch **4322** for the sine wave created by the filaments **4312**, and a pitch **4323** for the sine wave created by the filaments **4313**) and a pitch for each non-reinforced filament (e.g., a pitch **4341** for the sine wave created by the filament **4314**, a pitch **4342** for the sine wave created by the filament **4315**, a pitch **4343** for the sine wave created by the filament **4316**). In FIG. **8U**, the intersection points along the paired triple helix are substantially uniformly spaced, which can allow the distal portion **4390** to serve as an angiographic measurement ruler. For example, the distances between intersections can help an operator to measure the length of blood clots, the neck of an aneurysm, the length of a stenosis, etc. In some embodiments, a distance at least partially along the proximal neck **70**, along the distal neck **65**,

and/or along the bulbs has different dimensions than paired triple helix in the rest of the distal portion **4380**, which may serve as an identifier of the proximal neck **70**, the distal neck **65**, and/or the bulbs, for example beyond which the distal portion **4390** should not be deployed.

[0493] FIG. 8V is a schematic diagram illustrating an example setup of a braid carrier mechanism **4385** for the distal portion **4390** of FIG. 8U. In FIG. 8U, the half circles with dark shading indicate individual carriers **155** including spools **154** including shape memory filaments **156**, the half circles with hatched shading indicate individual carriers **155** including spools **154** including radiopaque filaments **156**, and the half circles with no shading indicate spindles without spools **154** or filaments **156**. In the arrangement illustrated in FIG. 8U, spindles 4o, 5i, 7o, 8i, 10o, 11i, 14i, 16o, 17i, 19o, 20i, 22o, 23i, 28o, 29i, 31o, 32i, 34o, 35i, 40o, 41i, 43o, 44i, 46o, 47i, 52o, 53i, 55o, 56i, 58o, 59i, 62i, 64o, 65i, 67o, 68i, 70o, 71i include spools **154** including shape-memory material (e.g., 39 of the 48 filaments **156** comprise shape-memory material), the spindles 1o, 2i, 13o, 25o, 26, 37o, 49o, 50i/61o include spools **154** including radiopaque material (e.g., 9 of the 48 filaments **156** comprise radiopaque material), and the remaining spindles are empty. The braid carrier mechanism **4385** setup illustrated in FIG. 8V can generate a pattern of radiopacity described with respect to FIG. 8U, for example a reinforced three phase helix (including a sine wave formed by each radiopaque filament pairs 1o/2i, 25o/26i, 49o/50i) and a non-reinforced three phase helix (including a sine wave formed by each single radiopaque filament 13o, 37o, 61o) or a reinforced three phase helix. Although some examples of the carrier braider **150** with 48 spindles **153** or individual carriers **155** are provided herein, some embodiments of the carrier braider **150** may include 6 to 144 spindles **153** or individual carriers **155** in accordance with the values provided above and/or carrier braiders **150** that have 6, 12, 24, 36, 48, 60, 72, 84, 96, 120, 144, etc. spindles **153** or individual carriers **155** and the number and positioning of the radiopaque filaments can remain as provided in the example braid carrier mechanism **4380** setup. Different weights are also possible. For example, a reinforced three phase helix may include three or more radiopaque filaments per phase. For another example, a non-reinforced three phase helix may include more than one radiopaque filament per phase, for example as long as the reinforced three phase helix in that paired three phase helix includes more filaments per wave such that the latter is relatively reinforced.

[0494] FIG. 8W illustrates a paired three phase helix including a reinforced triple helix and a non-reinforced triple helix. The reinforced triple helix includes a first sine wave formed by the two radiopaque filaments **4311**, a second sine wave formed by the two radiopaque filaments **4312**, and a third sine wave formed by the two radiopaque filaments **4313**. The non-reinforced three phase helix includes a first sine wave formed by the radiopaque filament **4314**, a second sine wave formed by the radiopaque filament **4315**, and a third sine wave formed by the radiopaque filament **4316**. In some embodiments, each sine wave within the reinforced three phase helix is offset from the adjacent sine wave within the reinforced three phase helix by about 120° and each sine wave within the non-reinforced three phase helix is offset from the adjacent sine wave within the non-reinforced three phase helix by about 120°.

[0495] FIG. 8X is a schematic side elevational view of yet another example embodiment of the distal portion **4600** of a

vascular treatment device illustrating an example pattern of radiopaque filaments, for example under x-ray. The distal portion **4600** may be the distal portion **100** of the device **10**, **20**, **30**, or **40**. The distal portion **4600** includes a plurality of woven spherical bulbs **4617**, **4619**, a woven neck **4631**, a proximal neck **70**, and a distal neck **65** along a longitudinal axis **4640**. The distal portion **4600** includes relatively low braid angle segments **4611**, **4615**. In some embodiments, the segments **4611**, **4615** have braid angles ranging from about 0° to about 90° (e.g., about 17°, about 22°, about 45°, etc.). Lower braid angle segments generally have lower PPI and tend to have relatively high porosity. Lower PPI can result in a larger pore size, which can allow adequate flow into perforating vessels or small blood vessels adjoining blood clot, an aneurysm, or a vascular malformation such as an arterio-venous fistula, which can maintain flow in these small but important blood vessels. The distal portion **4600** further includes a relatively high braid angle segment **4613**. In some embodiments, the segment **4613** has braid angles ranging from about 91° to about 180° (e.g., about 111°, about 112°, about 151°, etc.). Higher braid angle segments generally have a higher PPI and tend to have relatively low porosity. Higher PPI can result in a smaller pore size, which can decrease flow into an aneurysm or a vascular malformation such as an arterio-venous fistula, which can aid in thrombosis of the aneurysm or vascular malformation.

[0496] Referring back to FIG. 8A, at least two variables can be modified to impact porosity: (1) ability to vary the speed of rotation of the circular horn gear **152** for an entire rotation of the horn gear **152** in the horizontal direction **166** relative to the speed of motion of the vertical ring or puller **161** in the vertical direction **164** along the mandrel **162**; and (2) ability to start or stop movement of the vertical puller **161**, and, once stopped, ability to rearrange the spools **154** with filaments from one spindle **153** to another (“Start-Stop”). Changes in one or both of these variables can directly affect, for example, braid angle and porosity. In some embodiments in which the speed of rotation  $S_r$  in the horizontal direction of the circular horn gear **152** is faster than the speed of motion  $S_v$  in the vertical direction of the puller **161** such that the horn gear ratio ( $S_r/S_v$ ) is greater than 1.0, a high braid angle and relative low porosity can be obtained. In some embodiments in which the speed of rotation  $S_r$  in the horizontal direction of the circular horn gear **152** is slower than the speed of motion  $S_v$  in the vertical direction of the puller **161** such that the horn gear ratio ( $S_r/S_v$ ) is less than 1.0, a lower braid angle and a relative high porosity can be obtained.

[0497] In some embodiments, crossings of the radiopaque filaments of the distal portion **4600** can be used as a guide for deployment of the distal portion **4600**. For example, the “circumferential asymmetric” radiopaque pattern may serve as a visual guide to understand the deployment of woven bulbs by observation of an asymmetric pattern including low braid angles and the deployment of necks by observation of a symmetric pattern including high braid angles.

[0498] FIG. 8Y is a schematic diagram illustrating an example setup of a braid carrier mechanism **4680** for the distal portion **4600** of FIG. 8X illustrating a pattern of a “circumferential asymmetric helix.” In FIG. 8Y, the half circles with dark shading indicate individual carriers **155** including spools **154** including shape memory filaments **156**, the half circles with hatched shading indicate individual carriers **155** including spools **154** including radiopaque filaments **156**, and the half circles with no shading indicate

spindles without spools **154** or filaments **156**. In the arrangement illustrated in FIG. **8Y**, spindles 4o, 5i, 7o, 8i, 10o, 11i, 13o, 14i, 16o, 17i, 19o, 20i, 22o, 23i, 28o, 29i, 31o, 32i, 34o, 35i, 40o, 41i, 43o, 44i, 46o, 47i, 52o, 53i, 55o, 56i, 58o, 59i, 61o, 62i, 64o, 65i, 67o, 68i, 70o, 71i include spools **154** including shape-memory material (e.g., 39 of the 48 filaments **156** comprise shape-memory material) spindles 1o, 2i, 25o, 26i, 49o, 50i, 31o, 37o, 43o include spools **154** including radiopaque material (e.g., 9 of the 48 filaments **156** comprise radiopaque material), and the remaining spindles are empty. The braid carrier mechanism setup **4680** illustrated in FIG. **8Y** can generate a pattern of radiopacity described with respect to FIG. **8X**, for example a reinforced three phase helix and a non-reinforced asymmetric three phase helix to form a “circumferential asymmetric” radiopacity pattern. Although some examples of the carrier braider **150** with 48 spindles **153** or individual carriers **155** are provided herein, some embodiments of the carrier braider **150** may include 6 to 144 spindles **153** or individual carriers **155** in accordance with the values provided above and/or carrier braiders **150** that have 6, 12, 24, 36, 48, 60, 72, 84, 96, 120, 144, etc. spindles **153** or individual carriers **155**.

**[0499]** In some embodiments, each sine wave within the reinforced three phase helix is offset from the adjacent sine wave within the three phase helix by about  $120^\circ$  and each sine wave within the non-reinforced three phase helix is offset from the adjacent sine wave by about  $37.5^\circ$ . The reinforced three phase helix is asymmetrically offset from the non-reinforced three phase helix.

**[0500]** FIGS. **8L**, **8S**, and **8T-4** each include a scale to provide a rough, non-limiting, sizing of an example of a distal portion **100** and spacing between radiopaque filaments. In some embodiments, crossings of the radiopaque filaments of the distal portion **100** can be used as a rough measurement guide. For example, in FIG. **8S**, every two crossings and the distance between two helical intersection points is about 1 mm. For another example, in FIG. **8L**, every one crossing is about 2 mm. In a radially expanded state in a vessel, the distal portion **100** may not achieve full radial expansion (e.g., limited by the sidewalls of the vessel), so the guides are not precise, but can provide approximation for, e.g., deployment length, clot length, neck of the aneurysm, stenosis length, etc.

**[0501]** If the distance between helical intersection points is substantially uniform (e.g., about 5 mm), then the user can determine that unsheathing up to 4 intersection points unsheathes about 20 mm (4x5 mm) of the distal portion **100**. If the distance between helical intersection points is variable (e.g., about 5 mm proximate to the distal end of the distal portion **100** and about 10 mm proximate to the proximal end of the distal portion **100**, with stepped or intermediate distances therebetween), then the user can determine that visualization of wider distances are approaching unsheathing of the proximal end of the distal portion **100**, which can be useful, for example, when treating long clots (e.g., long clots in neuro and/or peripheral vessels, treatment of critical limb ischemia, etc.) and/or which can serve as a visual guide for when to stop unsheathing the distal portion **100** during device deployment.

**[0502]** Certain arrangements of radiopaque filaments, for example a double helix or a three phase helix, may be easier to see and/or use for length approximation. In some embodiments, a double helix may include between about 1 radiopaque strand and about 12 radiopaque strands concentrated around part of a circumference of a distal portion **100** (e.g.,

adjacent to each other, spaced by less than about 5 non-radiopaque filaments, less than about 3 non-radiopaque filaments, less than about 2 non-radiopaque filaments, etc.). In some embodiments, the double helix may comprise a simple double helix which may include about 2 radiopaque strands (e.g., one strand for each helix), a dual double helix which may include about 4 radiopaque strands (e.g., two strands for each helix), and/or a reinforced double helix which may include about 6 radiopaque strands (e.g., three strands for reinforcing each helix), about 8 radiopaque strands (e.g., four strands for reinforcing each helix), about 60 radiopaque strands (e.g., 30 strands for reinforcing each helix), etc. A double helix may be created, for example, by placing at least two spools **154** including radiopaque filaments **156** adjacent to each other around a circumference of the distal portion **100**. Circumferential adjacentness may be produced, for example, by placing spools **154** including radiopaque filaments **156** on adjacent spindles **153** or spindles **153** without a non-radiopaque filament therebetween on the yarn wheel **152**.

**[0503]** In some embodiments, the three phase helix may comprise a simple three phase helix, which may include about 3 radiopaque strands, a reinforced three phase helix, which may include about 4 radiopaque strands (e.g., two strands for reinforcing one of the phases and one strand for each of the other two phases), and/or a circumferential helix with a reinforced three phase helix, which may include between about 9 radiopaque strands (e.g., six strands for reinforcing the three phase helix and three strands for the non-reinforced three phase helix), about 12 radiopaque strands (e.g., nine strands for reinforcing the three phase helix, and three strands for the non-reinforced three phase helix), about 15 radiopaque strands (e.g., twelve strands for reinforcing the three phase helix, and three strands for the non-reinforced three phase helix), about 60 radiopaque strands (e.g., 54 strands for reinforcing each helix reinforcing the three phase helix, and six strands for the non-reinforced three phase helix), etc. In some embodiments, referring to FIG. **8U**, a ratio of the number of radiopaque filaments in the reinforced three phase helix to the number of radiopaque filaments in the non-reinforced three phase helix may include ratios of about 2:1, about 3:1, about 4:1, about 9:1, etc.

**[0504]** FIG. **8Z** is a schematic magnified side elevational view of still another example embodiment of a distal portion **4500** of a vascular treatment device illustrating an example pattern of radiopaque filaments **4520**. The distal portion **4500** may be the distal portion **100** of the device **10**, **20**, **30**, or **40**. The distal portion **4500** includes, in an expanded state, a textile structure including shape-memory filaments (not shown) and radiopaque filaments **4520**. The distal portion **4500** includes a plurality of zones **4510** along the longitudinal axis **4540**. The plurality of zones **4510** includes a first zone **4511**, a second zone **4513**, and a third zone **4515**. The first zone **4511** includes different braid angles than the second zone **4513**. The second zone **4513** includes different braid angles than the third zone **4515**. In the embodiment illustrated in FIG. **8Z**, the first zone **4511** includes the same braid angles than the third zone **4515**, although the first zone **4511** may include different braid angles than the third zone **4515**. In some embodiments, the radiopaque filaments **4520** form a “circumferential asymmetric helix” **4510**.

**[0505]** Referring again to FIG. **8A**, the braiding parameters may be varied to produce the desired properties of the textile structure **158**, including, for example braid angle, PPI, pore size, porosity, etc. There are at least two variables that can be

modified to directly affect the braid angle: (1) speed of rotation of the horn gear **152** for an entire rotation of the horn gear **152** in the horizontal direction **166**; and (2) speed of motion of the puller or ring **161** in the vertical direction **164** along the mandrel **162**. Changes in one or both of these variables can directly affect, for example, braid angle. In some embodiments in which the speed of rotation in the horizontal direction ( $S_h$ ) of the circular horn gear **152** is faster than the speed of motion in the vertical direction ( $S_v$ ) of the puller **161** such that the horn gear ratio ( $S_h/S_v$ ) is greater than 1.0, a high braid angle can be obtained. In some embodiments in which the speed of rotation in the horizontal direction of the circular horn gear **152** is slower than the speed of motion in the vertical direction of the puller **161** such that the horn gear ratio ( $S_h/S_v$ ) is less than 1.0, a lower braid angle can be obtained. Referring again to FIG. **8Z**, the first zone **4511** of the distal portion **4500** has a relatively low braid angle, implying that the horn gear ratio is less than 1.0, the second zone **4513** of the distal portion **4500** has a relatively high braid angle, implying that the horn gear ratio is greater than 1.0, and the third zone **4515** of the distal portion **4500** has a relatively low braid angle, implying that the horn gear ratio is less than 1.0.

[0506] Although shown with respect to a single radiopaque filament **4520** of a radiopaque pattern that may be formed, for example, by the braid carrier mechanism **2870** shown in FIG. **8G**, variation of the horn gear ratio can be used to vary braid angles of a plurality of shape-memory and radiopaque filaments in any braid carrier mechanism setup (e.g., the braid carrier mechanisms setups shown in FIGS. **8B**, **8I**, **8K**, **8N**, **8R**, **8T-3**, **8V**, etc.). In braid carrier mechanism setups including radiopaque filaments, the braid angle may be varied along the longitudinal length of the device being braided.

[0507] FIG. **9A** is a schematic magnified side elevational view of a portion of another example embodiment of a distal portion **8300** of a vascular treatment device illustrating an example pattern of one or more filaments **8320**. The distal portion **8300** may be the distal portion **100** of the device **10**, **20**, **30**, or **40**. The distal portion **8300** includes, in an expanded state, a textile structure including shape-memory and/or radiopaque filaments and a plurality of zones **8310**. The filament(s) **8320** may be part of a woven textile structure, for example as described herein. In some embodiments, at least one of the plurality of zones **8310** has a different porosity and/or pore size than at least one of the other of the plurality of zones **8310**. Referring back to FIG. **8A**, at least two variables can be modified to directly affect braiding parameters such as porosity or pore size: (1) ability to start or stop movement of the vertical puller **161**, and, once stopped, ability to rearrange the spools **154** from one spindle **153** to another spindle **153** (“Start-Stop”); and (2) ability to vary speed of rotation of portions of the circular horn gear **152**. In some embodiments, movement of the vertical puller **161** is temporarily stopped, and the spools **154** including filaments **156** are rearranged from one spindle **153** to another spindle **153** on the braid carrier mechanism **152** to create a different pattern (e.g., from symmetric as shown in FIG. **8V** to asymmetric as shown in FIG. **8Y**). Adjusting the arrangement of the braid carrier mechanism can vary the pore size in the horizontal plane on either side of the braid axis. In some other embodiments, the speed of rotation of the circular horn gear **152** for a portion of rotation of the yarn wheel **152** (e.g.,  $180^\circ$ , or for the western hemisphere of the yarn wheel **152**) is different compared to the remaining portion of rotation of the yarn wheel **152** (e.g.,  $180^\circ$ , or for the eastern hemisphere of

the yarn wheel **152**), which can vary pore size and/or porosity in the vertical plane on either side of the longitudinal axis.

[0508] In FIG. **9A**, the distal portion **8300** includes a first zone **8311**, a second zone **8312**, and a third zone **8315**. The second zone **8313** has a higher porosity and/or larger pore size than the first zone **8311** and the third zone **8315**. In some embodiments, the porosity and/or pore size of the second zone may be varied by adjusting at least one of Start-Stop and rotation of a portion of the yarn wheel **152** during the braiding process. In some embodiments, the filaments **8320** form a helix including troughs and peaks, for example at the sides the distal portion **8300** that the helix at least partially creates. In FIG. **9C**, the first zone **8311** and the third zone **8315** have a relatively high PPI and are less porous than the second zone **8313**. Higher PPI can result in a smaller pore size, which can decrease flow into an aneurysm or a vascular malformation such as an arterio-venous fistula, which can aid in thrombosis of the aneurysm or vascular malformation. The second zone **8313** has a relatively low PPI and is more porous than the first zone **8311** and the third zone **8315**. Lower PPI can result in a larger pore size, which can allow adequate flow into perforating vessels or small blood vessels adjoining blood clot, an aneurysm, or a vascular malformation such as an arterio-venous fistula, which can maintain flow in these small but important blood vessels.

[0509] FIG. **9B** is a schematic side elevational view of an example embodiment of forming the distal portion **8300** of FIG. **9A**. FIG. **9B** shows a braiding device or carrier braider **150** braiding a pattern in the distal portion **8300** including variable pore size. For example as described with respect to FIG. **8A**, the braiding device **150** includes a yarn wheel or braid carrier mechanism or circular horn gear **152** and a plurality of spindles **153** and individual carriers **155**. A spindle **153** is a stick on the circular horn gear **152**. A spool **154** is a hollow device that fits onto a spindle **153** and includes filaments **156** wound around it. An individual carrier **155** includes a spindle **153** and a spool **154** on the spindle **153**. The terms spindle, spool, and individual carrier may be used interchangeably depending on context. The individual carriers **155** include spools **154** including filaments **156** that are woven together to form the textile structure of the distal portion **8300**. Each spindle pair includes an outer spindle **5717** and an inner spindle **5715**. The filaments **156** each extend from an individual carrier **155** to a ring or vertical puller **161** over a mandrel along the central longitudinal axis **4840**, and are braided around the mandrel **160** along the central longitudinal axis **4840** by spinning the circular horn gear **152**, spinning the spindles **153**, and pulling the ring **161** away from the circular horn gear **152** in a vertical direction **164**. The distal portion **8300** includes filaments that are left leaning, for example the filaments **8320** that are shown to the left of the longitudinal axis **4840**, and right leaning, for example the filaments **8320** that are shown to the right of the longitudinal axis **4840**. In some embodiments, the left leaning filaments correlate with the individual carriers **4815** in the western hemisphere of the circular braid mechanism or circular horn gear **152** and the right leaning filaments correlate with the individual carriers **4825** in the eastern hemisphere of the circular braid mechanism or circular horn gear **152**. Although some examples of the carrier braider **150** with 4 spindles **153** or individual carriers **155** are provided herein, some embodiments of the carrier braider **150** may include 6 to 144 spindles **153** or individual carriers **155** in accordance with the values provided above and/or carrier braiders **150**

that have 6, 12, 24, 36, 48, 60, 72, 84, 96, 120, 144, etc. spindles **153** or individual carriers **155**. As the textile structure **8300** is woven at preform point **160**, the textile structure advances in the direction of the arrow **164**. The circular horn gear **152** spins in the direction of the arrows **166** in a horizontal plane around the longitudinal axis **4840**, and the spindles **153** rotate within the circular horn gear **152** to create the desired braiding pattern.

[0510] FIG. 9C is a schematic diagram illustrating an example setup of a braid carrier mechanism **2600** for forming the distal portion **8300** of FIG. 9A, illustrating an example pattern for creating variable pore size. In FIG. 9C, the half circles with dark shading indicate individual carriers **155** including spools **154** including shape memory filaments **154**, the half circles with hatched shading indicate individual carriers **155** including spools **154** including radiopaque filaments **156**, and the half circles with no shading indicate spindles without spools **154** or filaments **156**. Although some examples of the spindles **153** or individual carriers **155** are provided herein, the spindles **153** may include spools **154** including shape memory material, spools **154** including radiopaque material, be empty, be arranged in symmetric or asymmetric patterns, combinations thereof, and the like. In the arrangement illustrated in FIG. 9C, spindles 1o, 2i, 4o, 5i, 7o, 8i, 10o, 11i, 13o, 14i, 16o, 17i, 19o, 20i, 22o, 23i, 25o, 26i, 28o, 29i, 31o, 32i, 34o, 35i, 37o, 38i, 40o, 41i, 43o, 44i, 46o, 47i, 49o, 50i, 52o, 53i, 55o, 56i, 58o, 59i, 61o, 62i, 64o, 65i, 67o, 68i, 70o, 71i include spools **154** including shape-memory material (e.g., 48 of the 48 filaments **156** comprise shape-memory material) and the remaining spindles are empty. Although some examples of the carrier braider **150** with 48 spindles **153** or individual carriers **155** are provided herein, some embodiments of the carrier braider **150** may include 6 to 144 spindles **153** or individual carriers **155** in accordance with the values provided above and/or carrier braiders **152** that have 6, 12, 24, 36, 48, 60, 72, 84, 96, 120, 144, etc. spindles **153** or individual carriers **155**.

[0511] FIG. 9D is a schematic diagram illustrating another example setup of a braid carrier mechanism **2600** for forming the distal portion **8300** of FIG. 9A, illustrating another example pattern for creating variable pore size after rearranging the individual carriers **155** such that all of the spindles **153** with spools **154** including filaments **156** form spindle pairs, which can increase the number of empty spindle pairs and pore size. In the arrangement illustrated in FIG. 9D, the spindles 1o, 1i, 4o, 4i, 7o, 7i, 10o, 10i, 13o, 13i, 16o, 6i, 19o, 19i, 22o, 22i, 25o, 25i, 28o, 28i, 31o, 31i, 34o, 34i, 37o, 37i, 40o, 40i, 43o, 43i, 46o, 46i, 49o, 49i, 52o, 52i, 55o, 55i, 58o, 58i, 61o, 61i, 64o, 64i, 67o, 67i, 70o, 70i include spools **154** including shape-memory material (e.g., 48 of the 48 filaments **156** comprise shape-memory material) and the remaining spindles are empty. Compared to the arrangement illustrated in FIG. 9E, the spool **154** on spindle 2i was moved to the spindle 1i, the spool **154** on spindle 5i was moved to the spindle 4i, the spool **154** on spindle 8i was moved to the spindle 7i, the spool **154** on spindle 11i was moved to the spindle 10i, the spool **154** on spindle 14i was moved to the spindle 13i, the spool **154** on spindle 17i was moved to the spindle 16i, the spool **154** on spindle 20i was moved to the spindle 19i, the spool **154** on spindle 23i was moved to the spindle 22i, the spool **154** on spindle 26i was moved to the spindle 25i, the spool **154** on spindle 29i was moved to the spindle 28i, the spool **154** on spindle 32i was moved to the spindle 31i, the spool **154** on spindle 35i was moved to the

spindle 34i, the spool **154** on spindle 38i was moved to the spindle 37i, the spool **154** on spindle 41i was moved to the spindle 40i, the spool **154** on spindle 44i was moved to the spindle 43i, the spool **154** on spindle 47i was moved to the spindle 46i, the spool **154** on spindle 50i was moved to the spindle 49i, the spool **154** on spindle 53i was moved to the spindle 52i, the spool **154** on spindle 56i was moved to the spindle 55i, the spool **154** on spindle 59i was moved to the spindle 58i, the spool **154** on spindle 62i was moved to the spindle 61i, the spool **154** on spindle 65i was moved to the spindle 64i, the spool **154** on spindle 68i was moved to the spindle 67i, and the spool **154** on spindle 71i was moved to the spindle 70i. Although some examples of the carrier braider **150** with 48 spindles **153** or individual carriers **154** are provided herein, some embodiments of the carrier braider **150** may include 6 to 144 spindles **153** or individual carriers **155** in accordance with the values provided above and/or carrier braiders that have 6, 12, 24, 36, 48, 60, 72, 84, 96, 120, 144, etc. spindles **153** or individual carriers **155** and the number and positioning of the spools **154** including filaments **156** can remain as provided in the example braid carrier mechanism **2600** setup of FIG. 9D.

[0512] In some embodiments, for example the arrangement illustrated in FIG. 9C, can result in a braiding pattern of the distal portion **8300**, as noted in FIG. 9B, having a relatively high PPI and relatively low porosity, for example the distal segment **8311** of the distal portion **8300**. If the "Start-Stop" capability is activated after the braiding of the distal segment **8311** of the distal portion **8300**, and once the vertical puller or ring **161** is stopped to be able to rearrange the spools **154** including filaments **156** between spindles **153** in the arrangement illustrated in FIG. 9D, further braiding can result in a braiding pattern having a relatively low PPI and relatively high porosity, for example the middle segment **8313** of the distal portion **8300**. If the "Start-Stop" capability is again activated after the braiding of the middle segment **8313** of the distal portion **8300**, and once the vertical puller or ring **161** is stopped to be able to rearrange the spools **154** including filaments **156** between spindles **153** in the arrangement illustrated in FIG. 9C, further braiding can result in a braiding pattern having a relatively high PPI and relatively low porosity, for example the proximal segment **8315** of the distal portion **8300**.

[0513] In some embodiments, referring back to FIGS. 9B and 9C, the speed of rotation of the circular horn gear **152** for 180 degrees rotation of the yarn wheel, for example the speed of rotation  $S_{h-w}$  of the western hemisphere of individual carriers **4815** on the yarn wheel in the horizontal direction **4817**, is different compared to the remaining 180 degrees rotation of the yarn wheel, for example the speed of rotation  $S_{h-e}$  of the eastern hemisphere of individual carriers **4825** of the yarn wheel in the horizontal direction **4827**, which can vary the pore size in the vertical plane on either side of the longitudinal axis **4840**.

[0514] In the arrangement illustrated in FIGS. 9C and 9D, for example, if the speed of rotation  $S_{h-w}$  in the horizontal direction **4817** of the western hemisphere of the circular horn gear **152** is faster than the speed of motion  $S_v$  in the vertical direction of the puller **161**, the horn gear ratio ( $S_{h-w}/S_v$ ) is greater than 1.0, and a high braid angle can be obtained. For example, the higher braid angle segments may have braid angles ranging from about 91° to about 180° (e.g., about 111°, about 112°, about 151°, etc.). Higher braid angle segments generally have a higher PPI and tend to have relatively low

porosity. Higher PPI can result in a smaller pore size, which can decrease flow into an aneurysm or a vascular malformation such as an arterio-venous fistula, which can aid in thrombosis of the aneurysm or vascular malformation.

[0515] In the arrangement illustrated in FIGS. 9C and 9D, for example, if the speed of rotation  $S_{h-e}$  in the horizontal direction **4827** of the eastern hemisphere of the circular horn gear **152** is slower than the speed of motion  $S_y$  in the vertical direction of the puller **161**, the horn gear ratio ( $S_{h-e}/S_y$ ) is less than 1.0, and a lower braid angle can be obtained. For example, the lower braid angle segments may have braid angles ranging from about  $0^\circ$  to about  $90^\circ$  (e.g., about  $17^\circ$ , about  $22^\circ$ , about  $45^\circ$ , etc.). Lower braid angle segments generally have lower PPI and tend to have relatively high porosity. Lower PPI can result in a larger pore size, which can allow flow into perforating vessels or small blood vessels adjoining blood clot, an aneurysm, or a vascular malformation such as an arterio-venous fistula, which can maintain flow in these small but important blood vessels.

[0516] FIG. 9E is a schematic diagram illustrating an example embodiment of a mandrel for forming a distal portion of a vascular treatment device, for example the distal portion **11000** of FIG. 7A and/or the distal portion **11100** of FIG. 7B. FIG. 9F is a schematic diagram illustrating another example embodiment of a mandrel for forming a distal portion of a vascular treatment device, for example the distal portion **11000** of FIG. 7A and/or the distal portion **11100** of FIG. 7B. In the embodiments illustrated in FIGS. 9E and 9F, the bulbous mandrel can be customized for any Y-shaped configuration of the distal portion **100** of a vascular treatment device.

[0517] In FIG. 9E, the bulbous mandrel includes a spherical bulb or central anchor bulb **11205** and a plurality of retainer cavities including sprockets. In some embodiments, the retainer cavity and sprockets are interspersed on substantially the entire outer circumference of the central anchor bulb **11205**, and have the ability to rotate between about  $0^\circ$  and about  $180^\circ$ . Depending on the distal portion **100** to be manufactured, a first mandrel extension **11210** is coupled to a first sprocket **11212**, a second mandrel extension **11220** is coupled to a second sprocket **11222**, and a third mandrel extension **11230** is coupled to a third sprocket **11232**. The remaining sprockets can then be removed. In FIG. 9F, the bulbous mandrel includes a spherical bulb or central anchor bulb **11205** and a plurality of retainer cavities. Depending on the distal portion **100** to be manufactured, a first mandrel extension **11210** is coupled to a first sprocket **11262**, a second mandrel extension **11220** is coupled to a second sprocket **11242**, and a third mandrel extension **11230** is coupled to a third sprocket **11252**.

[0518] Although FIGS. 9E and 9F are shown and described with respect to three mandrel extensions **11210**, **11220**, **11230**, more or fewer mandrel extensions are also possible. The first mandrel extension **11210** comprises a generally spherical bulb and a generally cylindrical neck on each side of the generally spherical bulb, which can allow a neck formed over the first mandrel extension **11210** to include a generally spherical bulb and a generally cylindrical neck on each side of the generally spherical bulb. The second mandrel extension **11220** and the third mandrel extension **11230** are each generally cylindrical, which can allow a neck formed over the second mandrel extension **11220** and the third mandrel extension **11230** to be generally cylindrical. Mandrel extensions with any size and shape can be coupled to the central anchor

bulb **11205** depending on the desired size and shape of the neck to be formed thereover. In some embodiments, mandrel extensions can be selected to form a distal portion **100** customized for a pathology such as a location of an aneurysm, and even sized for a particular patient.

[0519] Referring again to FIG. 7A, the lengths  $L_1$ ,  $L_2$ ,  $L_3$ , and diameters  $D_1$ ,  $D_2$ ,  $D_3$ , the diameter of the central anchor bulb  $D_0$ , and the angulation of the mandrel extensions **11210**, **11220**, **11230** from the central anchor bulb **11205** can be customized to vasculature, a pathology such as location of the aneurysm at a vessel bifurcation, and/or aneurysm dimensions and blood vessel diameters and angulations in a patient in non-emergent situations. Referring again to FIG. 9B, a bulbous mandrel can be mounted on a carrier braider or braiding device for primary braiding over the customized bulbous mandrel. In some embodiments, the customized bulbous mandrel may include metals or alloys (e.g., comprising stainless steel or alloy of nickel and titanium). Suitable materials may include, for example, platinum, titanium, nickel, chromium, cobalt, tantalum, tungsten, iron, manganese, molybdenum, and alloys thereof including nickel titanium (e.g., nitinol), nickel titanium niobium, chromium cobalt, copper aluminum nickel, iron manganese silicon, silver cadmium, gold cadmium, copper tin, copper zinc, copper zinc silicon, copper zinc aluminum, copper zinc tin, iron platinum, manganese copper, platinum alloys, cobalt nickel aluminum, cobalt nickel gallium, nickel iron gallium, titanium palladium, nickel manganese gallium, stainless steel, shape memory alloys, etc.

[0520] Referring again to FIG. 7A, a textile structure formed over the central anchor bulb **11205** can form the distal generally spherical bulb **11012**, a textile structure formed over the mandrel extension **11210** can form the proximal segment including the bulb **11012** and the necks **11016**, **11017**, a textile structure formed over the mandrel extension **11220** can form the lateral distal neck **11019**, and a textile structure formed over the mandrel extension **11230** can form the distal neck **11018**. Referring again to FIG. 7B, a textile structure formed over the central anchor bulb **11205** can form the proximal generally spherical bulb **11105**, a textile structure formed over the mandrel extension **11210** can form the distal segment including the bulb **11110** and the necks **11115**, **11130**, a textile structure formed over the mandrel extension **11220** can form the lateral proximal neck **11120**, and a textile structure formed over the mandrel extension **11230** can form the proximal medial neck **11125**. Porosity of any section or portion thereof can be varied, for example as described herein (e.g., varying speed of a horn gear and/or puller, rearranging braid carrier mechanism setups).

[0521] After a tubular textile structure **158** is formed, the filaments **156** may be severed (e.g., close to the mandrel **162**), and the textile structure **158** may be removed from the mandrel **162**. FIG. 10A is a photograph illustrating an example woven tubular structure **158** after being removed from a mandrel **162**. The textile structure **158** is then slid onto a second mandrel having the same or a substantially similar outer diameter as the mandrel **162**. The textile structure **158** and the second mandrel are heat treated to impart shape memory to at least some of the filaments **156** (e.g., at least the filaments **156** comprising shape-memory material).

[0522] The temperature at which a material transforms from Martensite to Austenite depends at least partially on heat treatment of that material, which can influence the super-elastic or shape memory properties of a shape memory mate-

rial. For example, upon a change in temperature of an alloy of nickel and titanium, super-elastic or shape memory properties may be achieved.

[0523] In some embodiments, the heat treatment of shape memory alloy (e.g., comprising between about 55.8 wt % and about 57 wt % nickel) is performed in a fluidized sand bath at an annealing temperature between about 500° C. and about 550° C. (e.g., about 520° C.) for between about 5 minutes and about 10 minutes (e.g., about 7 minutes) in an atmosphere (e.g., ambient air). Between at least about room temperature and about body temperature, the textile structure **158** maintains the tubular shape absent stress-induced martensite. Heat treatment at annealing temperatures that are relatively high (e.g., between about 550° C. and about 600° C.) for between about 20 minutes and about 180 minutes can result in increasing the temperature range at which the textile structure **158** displays shape memory effect (e.g., greater than about body temperature). Heat treatment at annealing temperatures that are relatively low (e.g., between about 400° C. and about 450° C.) for between about 2 minutes and about 10 minutes can also result in increasing the temperature range at which the textile structure **158** displays shape memory effect (e.g., greater than about body temperature). In some embodiments, heat treatment of shape memory alloys, for example binary alloys of nickel and titanium with lower nickel content (e.g., between about 54.5 wt % and 55.3 wt % nickel) or ternary alloys of nickel, titanium, and cobalt, may be performed at annealing temperatures that are relatively low (e.g., between about 400° C. and about 450° C.) for between about 2 minutes and about 10 minutes may also result in the textile structure **158** that can maintain the tubular shape between at least about room temperature and about body temperature absent stress-induced martensite. The heat treatment temperature can be adjusted based on the particular shape-memory alloy. For example, a ternary alloy comprising cobalt may exhibit properties similar to a relatively low nickel shape-memory alloy.

[0524] In some embodiments, the heat treatment is performed in a fluidized sand bath in inert atmosphere (e.g., nitrogen, a mixture of hydrogen and nitrogen, a mixture of carbon monoxide, hydrogen, and nitrogen, etc.), which can inhibit surface oxidation (e.g., formation of nickel oxides in alloys of nickel and titanium) of the shape memory materials. In some embodiments, after heat treatment, the distal portion is then placed in a water bath (e.g., between about 20° C. and about 25° C.) for between about 15 minutes and 45 minutes (e.g., about 30 minutes). Rapid heating and/or cooling can help to retain the shape (e.g., to achieve the austenite finish temperature  $A_f$ ). In some systems, the mandrel **162** may be removed and the textile structure **158** may be heat treated on the mandrel **162** (e.g., without transfer to a second mandrel). After this initial heat treatment, the textile structure **158** may be referred to as a primary heat set or shape set structure.

[0525] FIG. 10B is another photograph illustrating an example woven tubular structure **4700** after being removed from a mandrel **162**, or from a secondary mandrel. The stray filament ends **4710** on the left side show that the ends **4710** of the filaments may benefit from further processing. For example, at least some of the ends of the filaments may be bent back, welded (e.g., ball welded), polished (e.g., to a dull end), coupled in sleeves, dip coated (e.g., in polymer such as polyurethane), coupled (e.g., adhered, welded, etc.), for example to an arcuate member (e.g., a radiopaque marker band **1720**, for example as illustrated in FIG. 5D), combinations thereof, and the like. Lack of filament end treatment

(e.g., no radiopaque marker band **1720**, polymer, etc.) can allow the distal portion **100** to have a lower profile when collapsed, for example because compression is only limited to the area of the filaments and spacing therebetween. In embodiments including a radiopaque marker band **1720**, the radiopaque marker band **1720** may include metals or alloys including, but not limited to, iridium, platinum, tantalum, gold, palladium, tungsten, tin, silver, titanium, nickel, zirconium, rhenium, bismuth, molybdenum, combinations, thereof, and the like. In some of the embodiments, a radiopaque marker band **1720** can be sandwich welded to the free end of the textile structure **158** (e.g., which is being fabricated into a distal portion **100** including bulbs). A radiopaque marker band **1720** may increase visibility of the distal end of the distal portion **100** during interventional procedures. In some embodiments, the ends of the filaments are not further processed. FIG. 10B also includes a United States quarter (\$0.25 or 25¢) to provide a rough, non-limiting, sizing of an example distal portion **100** and its filaments. In some embodiments, laser cutting can inhibit fraying of the filaments (e.g., by reducing mechanical shear forces during the cutting process).

[0526] FIG. 10C is a schematic exploded side elevational view of an example embodiment of a mandrel **170**, for example for heat treatment of distal portion **100** of a vascular treatment device. In some embodiments, the mandrel **170** includes a strand **172** and ten spherical bulbs **174**: three distal extra-small spherical bulbs **176** having an outer diameter configured to be oversized to extra-small vessel segments such as the M2 segments of the middle cerebral artery (e.g., about 1.5 mm to about 2.25 mm); the proximally-next three small spherical bulbs **177** having an outer diameter configured to be oversized to smaller vessel segments such as the distal M1 segment of the middle cerebral artery (e.g., about 2.25 mm to about 2.75 mm); the proximally-next two medium spherical bulbs **178** having an outer diameter configured to be oversized to medium vessel segments such as the proximal M1 segment of the middle cerebral artery (e.g., about 2.75 mm to about 3.25 mm); and the proximal two large spherical bulbs **179** having an outer diameter configured to be oversized to large vessel segments such as the distal supra-clinoid segment of the internal carotid artery (e.g., about 3.25 mm to about 4 mm). In some embodiments, at least some of the bulbs of the mandrel **170** have a size of about 1 mm to about 80 mm (e.g., about 2 mm to about 12 mm). Bulbs in range of about 1 mm to about 6 mm, about 3 mm to about 4.5 mm, about 0.5 mm to about 3 mm (e.g., about 3 mm), 0.75 mm to about 3 mm (e.g., about 3 mm), about 3.1 mm to about 3.9 mm (e.g., about 3.5 mm), about 4 mm to about 4.4 mm (e.g., 4 mm), and about 4.5 mm to about 7.5 mm (e.g., about 4.5 mm) may be particular beneficial for smaller clots and/or vessels (e.g., in the brain). Bulbs of the mandrel **170**, in range of about 4 mm to about 10 mm and about 5 mm to about 40 mm, may be particular beneficial for larger clots and/or vessels (e.g., in the leg). Although some example diameters are provided herein, some embodiments of the mandrel **170** may include diameters of the bulbs **176**, **177**, **178**, **179** in accordance with the values provided above and/or diameters that are within about  $\pm 5\%$ , about  $\pm 10\%$ , about  $\pm 15\%$ , or about  $\pm 20\%$  of any such values.

[0527] In some embodiments, the spherical bulbs **176** include a cylindrical hole, proximally to distally, **4941**, **4942**, **4943**, the spherical bulbs **177** include a cylindrical hole, proximally to distally, **4944**, **4945**, **4946**, the spherical bulbs

**178** include a cylindrical hole, proximally to distally, **4947**, **4948**, and the spherical bulbs **179** include a cylindrical hole, proximally to distally, **4949**, **4951**. The holes **4940** may, for example, be drilled through the centers of the spherical bulbs **174**. The outer diameters of the cylindrical holes **4940** may be oversized to the outer diameter of the strand **172** to allow the spherical bulbs **174** to be threaded in a direction **1722** over the end **1721** of the strand **172**. The bulbs **174** may be threaded one or more at a time. In some embodiments, the diameter or width of the strand **172** of the mandrel **170** for the distal portions **100** configured to be deployed in smaller blood vessels is in the range of about 0.15 mm to about 0.75 mm, about 0.35 mm to about 0.65 mm (e.g., about 0.38 mm), or about 0.4 mm to about 0.45 mm. In some embodiments, the diameter or width of the strand **172** of the mandrel **170** for distal portions **100** configured to be deployed in larger blood vessels is in the range of about 1 mm to about 40 mm (e.g., about 5 mm to about 20 mm). A tapered configuration of the mandrel **170** can allow for adequate and safe deployment of the distal portion **100** across blood vessels with multiple and/or varying diameters (e.g., vasculature that progressively reduces in size). In some embodiments, the mandrel **170** may include a wide variety of different bulb parameters such as bulb quantity, shape, size, spacing, phase-shifting with regards to the longitudinal axis or to a chord of the axis, material parameters, different neck parameters (e.g., neck diameter, neck length, etc.), alignment to the longitudinal axis or to a chord of the axis, combinations thereof, and the like.

[0528] FIG. 10D is a photograph showing a side elevational view of an example embodiment of a mandrel **170**. In some embodiments, the mandrel **170** is the third mandrel used in fabricating a distal portion **100**, after the mandrel **162** and the second mandrel used for heat treating. In some embodiments, the mandrel **170** is the second mandrel used in fabricating a distal portion **100**, after the mandrel **162** if the mandrel **162** is used for heat treating. The mandrel **170** includes a strand **172** and a plurality of bulbs **174**, for example after assembly of the pieces illustrated in FIG. 10C. In some embodiments, the strand **172** may comprise a wire (e.g., comprising stainless steel or alloy of nickel and titanium), a hypotube, etc. In some embodiments, the bulbs **174** may comprise a ball (e.g., comprising stainless steel or alloy of nickel and titanium). In some embodiments, the strand **172** has an outer diameter of between about 0.001 inches (approx. 0.025 mm) to about 0.0018 inches (approx. 0.045 mm). The bulbs **174** may comprise solid or hollow structures with a bore therethrough to allow the bulbs **174** to be positioned along the strand **172**. The bulbs **174** may be coupled to the strand by adhesion (e.g., epoxy), welding, soldering, combinations thereof, and the like. In some embodiments, the bulbs **174** have an outer diameter that is slightly smaller (e.g., about a wall thickness smaller or 1 to 2 strand thicknesses smaller) than a desired outer diameter of a bulb of the distal portion. The bulbs **174** illustrated in FIG. 10D include three generally spherical extra-small bulbs **176**, three generally spherical small bulbs **177**, two generally spherical medium bulbs **178**, and two generally spherical large bulbs **179**, which can help form the distal portion **1100** described above. Other selection and arrangement of bulbs **174** is also possible, for example to form other distal portions described herein or other types of distal portions. In some embodiments, for example to vary the diameter of the necks, the mandrel **170** includes hypotubes between the bulbs **174** having outer diameters corresponding to the desired inner diameter of the neck at that position. The

selection and arrangement of the bulbs **174** along the strand **172** and optional neck hypotubes allows the formation of a distal portion **100** having bulbs of nearly any quantity, shape, size, spacing, etc.

[0529] FIG. 10E is a schematic diagram illustrating an example embodiment of a woven tubular structure **158** around a mandrel **170**. FIG. 10E illustrates the textile structure **158** being tightened around the mandrel **170** using wire **180** (e.g., comprising stainless steel) between the two proximal large bulbs **179**. The textile structure **158** can also be tightened around the mandrel **170** using wire **180** or other means between other bulbs **174**.

[0530] FIG. 10F is a photograph illustrating an example embodiment a woven tubular structure **158** around a mandrel **170**. FIG. 10F illustrates the textile structure **158** being tightened around the mandrel **170** using wire **180** (e.g., comprising stainless steel or alloy of nickel and titanium) between the left bulb **178** and the right bulb **177**, between the right bulb **177** and the middle bulb **177**, and between the middle bulb **177** and the left bulb **177**. The frayed ends **4710** of the distal tip of the textile structure **158** are near the distal end of the strand **172**. Although the mandrel **170** illustrated in FIGS. 10C-10F can be used to form the distal portion **1100** of FIG. 2B, the mandrel **170** can also be used to form other distal portions **100**, for example not including medium or large bulbs (e.g., a distal portion including three bulbs **178**, **179** as illustrated in FIG. 10G, or any desired shape). The wire **180** is wrapped around the textile structure **158** between the bulbs **174**, and the textile structure **158** tightens around the bulbs **174**. In some embodiments, the wire **180** is wrapped tightly the entire spacing between the bulbs **174** (e.g., to form discrete necks and bulbs). In some embodiments, the wire **180** is wrapped mainly at an intermediate point between the bulbs **174** to create a more undulating pattern without discrete bulbs and necks. Discrete necks and bulbs, or pronounced undulation, may be more effective at treating hard clots than gentle undulations.

[0531] FIG. 10G is a schematic side elevational view of another example embodiment of a woven tubular structure **158** around a mandrel **170**. FIG. 10G illustrates the textile structure **158** being tightened around the mandrel **170** using wire **180** between the two large spherical bulbs **179** near the proximal end of the woven tubular structure **158** and using wire **182** between the medium spherical bulb **178** and the distal large spherical bulb **179**. In some embodiments, the wire **185** is wrapped tightly around the textile structure **158** including the strand **172** to form discrete valleys in the region of the wires **180** and **182**, and to form discrete hills in the region of the bulbs **178** and **179**.

[0532] FIG. 10H is a schematic side elevational view of another example embodiment of a distal portion **5100** of a vascular treatment device illustrating a high transition angle  $\theta_t$ . The distal portion **5100** includes, in an expanded state, a plurality of woven bulbs **5110** and a neck between the bulbs **5105**, **5107**. The distal portion **5100** may be formed, for example, by tightly wrapping wire, bangles, etc. around the textile structure **158** during a second heat treatment to form distinct bulbs **5105**, **5107**. FIG. 10I is a schematic side elevational view of another example embodiment of a distal portion **5200** of a vascular treatment device illustrating a low transition angle  $\theta_t$ . The distal portion **5200** includes, in an expanded state, a plurality of woven bulbs **5210** and a depression between the bulbs **5205**, **5207**. The distal portion **5200** may be formed, for example, by tightly wrapping wire,



bangles, etc. around the center of a neck of the textile structure **158** during a second heat treatment to form less distinct bulbs **5205**, **5207**. The distal portions **5100**, **5200** may be the distal portion **100** of the device **10**, **20**, **30**, or **40**. A hill-to-valley transition angle  $\theta_v$  is indicative of the amount of bulging of the bulbs relative to the necks, and is defined as the angle formed between the slope of the hill towards the valley and the plane perpendicular to the central longitudinal axis **4940**. In some embodiments, the angle  $\theta_v$  is between about  $0^\circ$  and about  $90^\circ$ . At higher transition angles  $\theta_v$ , the amount of bulging is higher, and, at lower transition angles  $\theta_v$ , the amount of bulging is lower. A higher transition angle  $\theta_v$  may enhance torsional rasping of hard clots adherent to the vessel endothelium. A lower transition angle  $\theta_v$  may enhance wall apposition of flow diverters or flow disruptors in the treatment of aneurysms or vascular malformations. Referring again to FIGS. **10H** and **10I**, a schematic representation of the measurement of transition angle  $\theta_v$  is shown. In the embodiment illustrated in FIG. **10H**, the transition angle  $\theta_v$  is about  $20^\circ$ . In the embodiment illustrated in FIG. **10I**, the transition angle  $\theta_v$  is about  $75^\circ$ .

[0533] FIG. **10J** is a schematic side elevational view of another example embodiment of a woven tubular structure **158** around a mandrel **175**. In some embodiments, bangles or c-shaped clamps **190** may be used to tighten the textile structure **158** around the mandrel **175** instead of or in addition to the wire **180**, **182**. FIG. **10J** illustrates the textile structure **158** being tightened around the mandrel **175** using bangles or c-shaped clamps **187**, instead of wire, between the two large spherical bulbs **179** near one end of the woven tubular structure **158** and using bangles or c-shaped clamps **189** between the medium spherical bulb **178** and the left large spherical bulb **179**, instead of wire, near the other end of the woven tubular structure **158**. The bangles **190** may include a slit **191** that allows the bangle **190** to be pried open and wrapped around the textile structure **158** and the mandrel **175** but small enough that filaments of the textile structure **158** generally cannot protrude out of the slit **191**.

[0534] FIG. **10K** is a schematic side elevational view of yet another example embodiment of a woven tubular structure **158** around a mandrel **5300**. FIG. **10K** illustrates the textile structure **158** being tightened around the mandrel **5300** including the strand **172** using three different types of bangles or c-shaped clamps **5305**, **5307**, **5309** and wire **5303** to form discrete valleys and discrete hills in the region of the bulbs **177** and **178**. In some embodiments, the bangle has a length close to that of the neck. In some embodiments, the bangle is thin enough that a plurality of bangles may be placed between the bulbs **174**. In some embodiments as illustrated in FIG. **10K**, circumferential ends of the bangles or c-shaped clamps may be circumferentially spaced by a slit **191** as shown by the bangle **5305**, but as shown by the bangle **5307**, longitudinally overlap or circumferentially overlap as shown by the bangle **5309**, etc. In some embodiments, temporary high-temperature adhesive may be used instead of or in addition to mechanical fasteners such as wire and/or bangles.

[0535] The textile structure **158** to the left of the left bulb **176** or the distal-most bulb may also be secured to the strand **172** to form the distal neck **65**. The portions of the strand **172** beyond the bulbs **174** may include markers to help determine the length of any proximal and distal necks. In some embodiments, the distal neck **65** may be curled, for example into a pigtail (e.g., by curling the strand **172** to the left of the left bulb **176**).

[0536] In some embodiments, the strand **172** may be substantially omitted. For example, the bulbs **174** can be placed inside the textile structure **158** and then the textile structure **158** tightened around each side of the bulbs **174**. An external template, for example, may be used to ensure proper spacing. Such a method may increase adaptability for forming different types of distal portions **100** using the same bulbs **174**. In some embodiments, the strand **172** may be removed from the bulbs **174** after securing the textile structure **158** around the bulbs **174**.

[0537] The textile structure **158** and the bulbs **174**, and optionally the strand **172**, are heat treated to impart shape memory to at least some of the filaments (e.g., at least the filaments **156** comprising shape memory material). In some embodiments, the secondary heat treatment of shape memory (e.g., comprising between about 55.8 wt % and about 57 wt % nickel) is at a temperature between about  $500^\circ\text{C}$ . and about  $550^\circ\text{C}$ . (e.g., about  $525^\circ\text{C}$ .) for between about 3 minutes and about 10 minutes (e.g., about 5 minutes) in an atmosphere (e.g., a sand bath fluidized with ambient air). As described herein, certain such heat treatment processes can maintain the shape of the distal portion **100** (e.g., including the bulbs and necks) between at least about room temperature and about body temperature absent stress-induced martensite, for example because the austenitic finish temperature  $A_f$  is between about  $10^\circ\text{C}$ . and about  $18^\circ\text{C}$ . (e.g., the distal portion **100** is super-elastic at temperatures greater than about  $18^\circ\text{C}$ .).

[0538] In some embodiments, the secondary heat treatment of shape memory (e.g., comprising between about 54.5 wt % and about 55.3 wt % nickel) is at a temperature between about  $400^\circ\text{C}$ . and about  $450^\circ\text{C}$ . (e.g., about  $425^\circ\text{C}$ .) for between about 3 minutes and about 10 minutes (e.g., about 5 minutes) in an atmosphere (e.g., a sand bath fluidized with ambient air). As described herein, certain such heat treatment processes can maintain the shape of the distal portion **100** (e.g., including the bulbs and necks) between at least about room temperature and about body temperature absent stress-induced martensite, for example because the austenitic finish temperature  $A_f$  is between about  $10^\circ\text{C}$ . and about  $18^\circ\text{C}$ . (e.g., the distal portion **100** is super-elastic at temperatures greater than about  $18^\circ\text{C}$ .).

[0539] In some embodiments, the secondary heat treatment of shape memory (e.g., comprising between about 55.8 wt % and about 57 wt % nickel) is at a temperature between about  $400^\circ\text{C}$ . and about  $450^\circ\text{C}$ . (e.g., about  $425^\circ\text{C}$ .) for between about 3 minutes and about 10 minutes (e.g., about 5 minutes) in an atmosphere (e.g., a sand bath fluidized with ambient air). Certain such heat treatment processes can maintain the tubular shape of the distal portion **100** (e.g., without the bulbs and necks) between at least about room temperature and about body temperature absent stress-induced martensite, for example because the austenitic finish temperature  $A_f$  is increased from between about  $10^\circ\text{C}$ . and about  $18^\circ\text{C}$ . to between about  $25^\circ\text{C}$ . and about  $37^\circ\text{C}$ . (e.g., the distal portion **100** slowly transitions to the bulb and neck shape at temperatures between about  $25^\circ\text{C}$ . and  $37^\circ\text{C}$ .). This dual heat treatment and slow shape transformation at room and/or body temperature can be referred to as one-way shape memory effect.

[0540] In some embodiments, the secondary heat treatment of shape memory (e.g., comprising between about 54.5 wt % and about 55.3 wt % nickel) is at a temperature between about  $500^\circ\text{C}$ . and about  $550^\circ\text{C}$ . (e.g., about  $525^\circ\text{C}$ .) for between

about 20 minutes and about 180 minutes (e.g., about 25 minutes) in an atmosphere (e.g., a sand bath fluidized with ambient air). Certain such heat treatment processes can maintain the tubular shape of the distal portion **100** (e.g., without the bulbs and necks) between at least about room temperature and about body temperature absent stress-induced martensite, for example because the austenitic finish temperature  $A_f$  is increased from between about 10° C. and about 18° C. to between about 25° C. and about 37° C. (e.g., the distal portion **100** slowly transitions to the bulb and neck shape at temperatures between about 25° C. and 37° C.).

**[0541]** In some embodiments, the secondary heat treatment of shape memory (e.g., comprising between about 55.8 wt % and about 57 wt % nickel) is at a temperature between about 400° C. and about 450° C. (e.g., about 425° C.) for between about 3 minutes and about 10 minutes (e.g., about 5 minutes) in an atmosphere (e.g., a sand bath fluidized with ambient air), which can have the effect described above. In some embodiments, a tertiary heat treatment may be performed, for example to impart the shape of the distal portion **100** shown in FIG. 27L at certain temperatures. In certain such embodiments, the tertiary heat treatment of shape memory (e.g., comprising between about 55.8 wt % and about 57 wt % nickel) is at a temperature between about 500° C. and about 550° C. (e.g., about 525° C.) for between about 3 minutes and about 10 minutes (e.g., about 5 minutes) in an atmosphere (e.g., a sand bath fluidized with ambient air). Certain such heat treatment processes can maintain the spiral or twisted or helical shape of the distal portion **100** between about 10° C. and about 18° C. absent stress-induced martensite, which can be achieved in a body, for example, by injecting cold saline (e.g., between about 5° C. and about 18° C.) for a localized temperature change or cooling effect. This triple heat treatment can be referred to as two-way shape memory effect.

**[0542]** In some embodiments, the secondary heat treatment of shape memory (e.g., comprising between about 54.5 wt % and about 55.3 wt % nickel) is at a temperature between about 500° C. and about 550° C. (e.g., about 525° C.) for between about 20 minutes and about 180 minutes (e.g., about 25 minutes) in an atmosphere (e.g., a sand bath fluidized with ambient air), which can have the effect described above. In some embodiments, a tertiary heat treatment may be performed, for example to impart the shape of the distal portion **100** shown in FIG. 27L at certain temperatures. In certain such embodiments, the tertiary heat treatment of shape memory (e.g., comprising between about 54.5 wt % and about 55.3 wt % nickel) is at a temperature between about 400° C. and about 450° C. (e.g., about 425° C.) for between about 3 minutes and about 10 minutes (e.g., about 5 minutes) in an atmosphere (e.g., a sand bath fluidized with ambient air). Certain such heat treatment processes can maintain the spiral or twisted or helical shape of the distal portion **100** between about 10° C. and about 18° C. absent stress-induced martensite, which can be achieved in a body, for example, by injecting cold saline (e.g., between about 5° C. and about 18° C.) for a localized temperature change or cooling effect.

**[0543]** The secondary and/or tertiary heat treatment temperature can be adjusted based on the particular shape-memory alloy. For example, a ternary alloy comprising cobalt may exhibit properties similar to a relatively low nickel shape-memory alloy.

**[0544]** In some embodiments, after heat treating, the distal portion is then placed in a water bath (e.g., between about 20° C. and about 25° C.) for between about 15 minutes and 45

minutes (e.g., about 30 minutes). Rapid heating and/or cooling can help to retain the shape (e.g., to achieve the austenite finish temperature  $A_f$ ). After this second heat treatment, the textile structure **158** may be referred to as a secondary heat set or shape set structure.

**[0545]** FIG. 10L is a schematic side elevational view of an example embodiment of removal of a mandrel from a woven tubular structure **158**. The wire, bangles, adhesive, etc. has been removed after heat treating to impart the shape of the mandrel to the textile structure. The mandrel includes a first mandrel piece **5010** and a second mandrel piece **5020**. The first mandrel piece **5010** is shown being removed from one side (proximal or distal), as indicated by the arrow **5025**, and the second mandrel piece **5020** is shown being removed from the other side, as indicated by the arrow **5030** (e.g., by being separable in an intermediate portion between the first mandrel piece **5010** and the second mandrel piece **5020**). In some embodiments, after heat treatment, removing the mandrel piece **5020** including the proximal four spherical bulbs in the proximal direction and removing the mandrel piece **5010** including the distal six spherical bulbs **5010** in the distal direction may inhibit damage to the integrity of the woven tubular structure **158**. A one piece mandrel or a multiple piece mandrel may also be removed from one side. Although some examples of mandrels are provided herein, some embodiments of mandrels may include a wide variety of different bulb parameters such as bulb quantity, shape, size, spacing, phase-shifting with regards to the longitudinal axis or to a chord of the axis, material parameters, different neck parameters (e.g., neck diameter, neck length, etc.), alignment to the longitudinal axis or to a chord of the axis, number of mandrels, combinations thereof, and the like.

**[0546]** The primary heat treatment in the cylindrical shape can allow the bulbs to radially expand to at least the diameter of the mandrel **162** without being damaged, and the secondary heat treatment can provide shape setting. In some embodiments, the first heat treatment process may be omitted (e.g., the textile structure **158** slid off the mandrel **162** and then onto the mandrel **170** (e.g., secured with wires, bangles, adhesive, etc.) with no primary heat treatment).

**[0547]** FIG. 10M is a schematic partial cut away side view of an example embodiment of heat treatment device. In some embodiments, the heat treatment device comprises a fluidized sand bath **5400**. The fluidized sand bath **5400** includes an outer wall **5410** and an inner thermal insulation layer **5430**. The fluidized sand bath **5400** includes a constrictive air inlet gate **5455** that allows the inflow of ambient air for heat treatment at atmosphere, or inflow of select gases (e.g., nitrogen, a mixture of hydrogen and nitrogen, a mixture of carbon monoxide, hydrogen, and nitrogen, combinations thereof, and the like) for heat treatment in an inert atmosphere. In some embodiments, the heat treatment is performed in a fluidized sand bath **5400** in inert atmosphere to inhibit oxidation of the surface of shape memory material, for example to inhibit formation of nickel oxides in alloys of nickel and titanium, during heat treatment.

**[0548]** In some embodiments, the heat treatment device **5400** includes an external air inflow regulator **5450** having an adjustable height  $h_1$ , which can regulate the velocity of the air inflow into the inner chamber **5415** of the sand bath **5400** through the constrictive air inlet gate **5455**, to create an adequate fluidized state in the sand bath **5400**. The external air inflow regulator **5450** is at a height  $h_1$  above the ground, which can be adjusted by increasing or decreasing the height

$h_1$ , has a pressure  $P_1$ , and a velocity of gas  $v_1$ . The gas **5425** entering the inner chamber **5415** of the sand bath **5400** through the constrictive air inlet gate **5455** is at a height  $h_2$  above the ground, has a pressure  $P_2$ , and a velocity of gas  $v_2$ . As the sum of the kinetic energy per unit volume ( $\frac{1}{2}\rho v^2$ ), the potential energy per unit volume ( $\rho gh$ ), and the pressure energy ( $P$ ) remain the same, the density of the gas  $\rho$  and the acceleration due to gravity  $g$  ( $980 \text{ cm/second}^2$ ) remain constant, the velocity of the gas  $v_2$  entering the inner chamber **5415** of the sand bath **5400** can be calculated using Equation 1:

$$\frac{1}{2}\rho v_1^2 + \rho gh_1 + P_1 = \frac{1}{2}\rho v_2^2 + \rho gh_2 + P_2$$

or, rearranged,  $v_2 = \sqrt{[v_1^2 + 1960(h_1 - h_2) + 2(P_1 - P_2)]/\rho}$  (Eq. 1)

[0549] In some embodiments, if the pressures  $P_1$  and  $P_2$  are equal to atmospheric pressure ( $P_1 = P_2 = P_{atm}$ ), the height  $h_2$  of the constrictive air inlet gate **5455** is at ground level ( $h_2 = 0$ ), and the gas velocity at the level of the external air inflow regulator **5450** is initially at rest ( $v_1 = 0$ ), then the velocity  $v_2$  of the gas entering the inner chamber **5415** of the sand bath **5400** is directly proportional to the height  $h_1$  of the external air inflow regulator **5450**. By increasing the height  $h_1$  of the external air inflow regulator **5450**, the velocity  $v_2$  of the gas can be increased, and  $v_2$  can be calculated in  $\text{cm}^3/\text{s}$  using Equation 2:

$$v_2 = \sqrt{(1960 \times h_1)} \quad (\text{Eq. 2})$$

[0550] In some embodiments, the sand bath **5400** includes a fail safe temperature regulator **5460** and an electric energy regulator **5465**. The fail safe temperature regulator **5460** can help regulate the temperature within the fluidized sand bath **5400**. For example, during the heat treatment of an alloy of nickel and titanium, if the temperature is above  $550^\circ \text{C.}$ , the fail safe temperature regulator **5460** may turn off the air inlet gate **5455** or, through the electric energy regulator **5465**, turn off the power to a heating element **5440**, as elevated annealing temperatures may adversely impact the  $A_f$  temperature as discussed herein. In some embodiments, the electric energy regulator **5465** can help regulate the voltage (AC or DC voltages) to inhibit electrical surges that may increase or decrease the temperature of the fluidized sand bath **5400** through the heating element **5440**. For example, if an electrical surge during the heat treatment of an alloy of nickel and titanium impacted the heating element **5440** and increased the temperature above  $550^\circ \text{C.}$ , the electric energy regulator **5465** may turn off the power to the heating element **5440**, as elevated annealing temperatures may adversely impact the  $A_f$  temperature as discussed herein. In some embodiments, the fail safe temperature regulator **5460** and the electric energy regulator **5465** may be controlled and regulated by sensors, for example thermal sensors, pressure sensors, electrical sensors, combinations thereof, and the like.

[0551] In the example embodiment illustrated in FIG. 10M, the gas **5425** that enters through the air inlet gate **5455** passes through a porous plate **5445** and a heating element **5440** prior to entering the inner chamber **5415** of the sand bath **5400**. The heating element **5440** may be electrically controlled and regulated via the fail safe temperature regulator **5460** and/or the electric energy regulator **5465**. The inner chamber **5415** of the sand bath **5400** includes sand bath media **5420**, for example dry inert non-flammable particles such as alumina (aluminum oxide), metallic beads such as stainless steel, combinations thereof, and the like. Fluidized sand bath media or particles **5420** may have a melting point and/or boiling

point well above the heat treatment temperature such that solidification, which could otherwise occur upon cooling (e.g., as in salt baths) and fumes (e.g., as in hot oil baths) are inhibited.

[0552] In the embodiment illustrated in FIG. 10M, when the gas **5425** is passed through the sand bath media or particles (e.g., aluminum oxide particles) **5420** via the porous plate **5445** and the heating element **5440**, the sand bath media **5420** are separated and suspended in the gas flow **5425** and take on the appearance of a boiling liquid with excellent heat transfer characteristics. When the fluidized sand bath media **5420** are heated, heat is distributed quickly and evenly throughout the sand bath **5400** and transferred rapidly to any devices or components **5435** in the sand bath **5400**.

[0553] In some embodiments, the fluidized sand bath **5400** comprises a detachable flange **5405** that covers the roof of the sand bath **5400**. The detachable flange **5405** of FIG. 10M includes a handle **5487** and one or more hollow conduits **5475** to allow passage of the arms of the container or basket **5470** carrying the devices or components **5435** being heat treated. The container **5470** may take a variety of shapes, for example, sphere, oblong, egg, oval, ellipse, helical, triangle, rectangle, parallelogram, rhombus, square, diamond, pentagon, hexagon, heptagon, octagon, nonagon, decagon, trapezoid, trapezium, other polygons, or bulged versions of these and other shapes, combinations thereof, and the like, based on the devices or components **5435** being heat treated. The arms of the container **5470** may include single filament wires, multi-filament wires, hypotubes, combinations thereof, and the like. In some embodiments, the arms of the container **5470** are reversibly attached to the flange **5405** via detachable air-sealant rivets **5480** on the outside of the flange **5405**, in which case the arms of the container **5470** pass through the hollow conduits **5475**, on the inside of the flange **5405**, in which case the arms of the container **5470** do not pass through the hollow conduits **5475**, or on both the inside and the outside of the flange **5405**. The reversible attachment points of the arms of the container **5470** to the air-sealant rivets **5480** may include a luer lock mechanism, a ball and socket mechanism, a wire and hook mechanism, a c-shaped clasp and hook mechanism, combinations thereof, and the like. The detachable flange **5405** can allow placement of the container **5470** with the devices or components **5435** being heat treated in the fluidized sand bath **5400** and/or removal of the container **5470** and the devices or components **5435** from the fluidized sand bath **5400** for placement in the cooling bath after heat treatment.

[0554] FIG. 11A is a schematic side elevational view of an example embodiment of braiding around a mandrel **162**. For example, FIG. 11A schematically shows what is occurring in FIGS. 8A and 8D. The mandrel **162** may be used in a heat treatment process to impart a cylindrical shape, or the textile structure may be slid off of the mandrel **162** for heat treatment on another mandrel.

[0555] FIG. 11B is a schematic side elevational view of another example embodiment of braiding around a mandrel **5600**. The mandrel **5600** includes bulbs **174** and strand **172**, for example as describe with respect to FIGS. 10C and 10D. The textile structure **158** may be braided around the mandrel **5600** so that woven bulbs **5610** are formed during the braiding process, for example the woven bulbs **5612**, **5614** with a woven neck **5620** between the woven bulbs **5612**, **5614**. The textile structure **158** may be heat treated on the mandrel **5600** to impart the bulb shapes, reducing manufacturing steps compared to a two-step heat treatment. During or after the braid-

ing process, bangles, wire, adhesive, etc. may be used to secure portions of the textile structure more tightly to the mandrel **5600**, for example as described with respect to FIGS. **10G**, **10J**, and **10K**. In some embodiments, a single heat treatment after braiding around a bulbous mandrel **5600** as illustrated in FIG. **11B** may include the same parameters as the second heat treatment around the mandrel **170** as described above.

[0556] FIG. **11C** is a schematic side elevational view of an example embodiment of forming a textile structure. The textile structure **158** may form a distal portion of a vascular treatment device, for example of the distal portion **100** of the device **10**, **20**, **30**, or **40**. For example as described with respect to FIG. **8A** and/or FIG. **9B**, the braiding device **5700** includes a yarn wheel or braid carrier mechanism or circular horn gear **152** and a plurality of spindles **153** and individual carriers **155**. A spindle **153** is a stick on the circular horn gear **152**. A spool **154** is a hollow device that fits onto a spindle **153** and includes filaments **156** wound around it. An individual carrier **155** includes a spindle **153** and a spool **154** on the spindle **153**. The terms spindle, spool, and individual carrier may be used interchangeably depending on context. The individual carriers **155** include spools **154** including filaments **156** that are woven together to form the textile structure **158** of the distal portion **100**. The filaments **156** each extend from an individual carrier **155** to a ring or vertical puller **161** over a bulbous mandrel **5710** comprising spherical bulbs (e.g., the mandrel **5600** of FIG. **11B**), and are braided around the bulbous mandrel **5710** by spinning the circular horn gear **152**, spinning the spindles **153**, and pulling the ring **161** away from the circular horn gear **152** in a vertical direction **164**. As the textile structure **158** is woven at preform point **160**, the textile structure **158** advances in the direction of the arrow **164**. The circular horn gear **152** spins in the direction of the arrows **166** in a horizontal plane, and the spools **154** including filaments **156** on the spindles **153** rotate within the circular horn gear **152** to create the desired braiding pattern including plurality of woven bulbs **174**, which includes in this example two large spherical bulbs **179** and two medium spherical bulbs **178**, and necks between the bulbs **174**. Although some examples of the carrier braider **150** with 4 spindles **153** or individual carriers **155** are provided herein, some embodiments of the carrier braider **150** may include 6 to 144 spindles **153** or individual carriers **155** in accordance with the values provided above and/or carrier braiders **150** that have 6, 12, 24, 36, 48, 60, 72, 84, 96, 120, 144, etc. spindles **153** or individual carriers **155**. The textile structure **158** may be heat treated on the mandrel **5710** to impart the bulb shapes, reducing manufacturing steps compared to a two-step heat treatment. In some embodiments, a single heat treatment after braiding around a bulbous mandrel **5710** as illustrated in FIG. **11C** may include the same parameters as the second heat treatment around the mandrel **170** as described above.

[0557] FIG. **11D** is a schematic side elevational view of another example embodiment of forming a textile structure **158**. The textile structure **158** may form a distal portion of a vascular treatment device, for example of the distal portion **100** of the device **10**, **20**, **30**, or **40**. For example as described with respect to FIG. **8A**, FIG. **9B**, and/or FIG. **11C**, the braiding device **5800** includes a yarn wheel or braid carrier mechanism or circular horn gear **152** and a plurality of spindles **153** and individual carriers **155**. A spindle **153** is a stick on the circular horn gear **152**. A spool **154** is a hollow device that fits onto a spindle **153** and includes filaments **156**

wound around it. An individual carrier **155** includes a spindle **153** and a spool **154** on the spindle **153**. The terms spindle, spool, and individual carrier may be used interchangeably depending on context. The individual carriers **155** include spools **154** including filaments **156** that are woven together to form the textile structure **158** of the distal portion **100**. Each spindle pair **5720** includes an outer spindle or individual carrier **5717** and an inner spindle or individual carrier **5715**. The filaments **156** each extend from an individual carrier **155** to a ring or vertical puller **161** over a bulbous mandrel **5710** comprising spherical bulbs (e.g., the mandrel **5600** of FIG. **11B**), and are braided around the bulbous mandrel **5710** by spinning the circular horn gear **152**, spinning the spindles **153**, and pulling the ring **161** away from the circular horn gear **152** in a vertical direction **164**. As the textile structure **158** is woven at preform point **160**, the textile structure **158** advances in the direction of the arrow **164**. The circular horn gear **152** spins in the direction of the arrows **166** in a horizontal plane, and the spools **154** including filaments **156** on the spindles **153** rotate within the circular horn gear **152** to create the desired braiding pattern including a plurality of woven bulbs **174**, which in this example includes two large spherical bulbs **179** and two medium spherical bulbs **178**, and necks between the bulbs **174**. The textile structure **158** may include a plurality of segments, at least one of the segments having a different pore size than at least one other segment. For example, in the textile structure **158** illustrated in FIG. **11D**, the distal segment **5810** has relatively high PPI and has relatively low porosity, the middle segment **5820** has relatively low PPI and has relatively high porosity, and the proximal segment **5830** has relatively high PPI and has relatively low porosity. Although some examples of the carrier braider **150** with 4 spindles **153** or individual carriers **155** are provided herein, some embodiments of the carrier braider **150** may include 6 to 144 spindles **153** or individual carriers **155** in accordance with the values provided above and/or carrier braiders **150** that have 6, 12, 24, 36, 48, 60, 72, 84, 96, 120, 144, etc. spindles **153** or individual carriers **155**. The textile structure **158** may be heat treated on the mandrel **5710** to impart the bulb shapes, reducing manufacturing steps compared to a two-step heat treatment. In some embodiments, a single heat treatment after braiding around a bulbous mandrel **5710** as illustrated in FIG. **11D** may include the same parameters as the second heat treatment around the mandrel **170** as described above.

[0558] FIG. **11E** is a perspective view of an example embodiment of a distal portion **5900** of a vascular treatment device, for example the result of the braiding process illustrated in FIG. **11D**. Referring again to FIGS. **2B** and **2C**, the distal portion **5900** in FIG. **11E** comprises a plurality of woven bulbs (**1112**, **1114**, **1116**, and **1118**) and woven necks similar to the distal portion **1100** in FIGS. **2B** and **2C**, with a modification being segments **5810**, **5820**, **5830**, **5840** having variable pore size. In some embodiments, the braid carrier mechanism **2600** setup illustrated in FIG. **9C** can form a braiding pattern of the distal portion **158** as shown in FIG. **11E**, in which the distal segment **5810**, for example, has a relatively high PPI and has relatively low porosity. If the "Start-Stop" capability is activated after the braiding the distal segment **5810**, and once the vertical puller or ring **161** is stopped to allow the spools **154** including filaments **156** to be rearranged between one spindle **153** and another spindle **153** in a symmetric pattern or an asymmetric pattern by increasing the number of empty spindle pairs, for example the braid

carrier mechanism 2650 setup illustrated in FIG. 9D, the middle segment 5820 can have a relatively low PPI and can have relatively high porosity.

[0559] In some embodiments, if the “Start-Stop” capability is activated again after braiding the middle segment 5820, and once the vertical puller or ring 161 is stopped to allow the spools 154 including filaments 156 to be rearranged between one spindle 153 and another spindle 153 in another pattern, for example back to the braid carrier mechanism 2600 setup illustrated in FIG. 9C, the proximal segment 5830 can have a relatively high PPI and can have relatively low porosity. Higher PPI can result in a smaller pore size, which can decrease flow into an aneurysm or a vascular malformation such as an arterio-venous fistula, which can aid in thrombosis of the aneurysm or vascular malformation or serve to filter any debris or emboli that may be released during thrombectomy. In some embodiments, by alternating between the arrangements of the braid carrier mechanism illustrated in FIGS. 9C and 9D, low porosity and/or high porosity segments of the distal portion can be achieved.

[0560] Referring again to FIG. 10L, for example, after the textile structure 158 has been removed from the mandrel 170 after the second heat treatment, the proximal and distal ends may be trimmed to a desired size. For example, precise or approximate proximal and distal necks may be formed by laser cutting, or mechanically cutting a certain distance from a proximal-most or distal-most bulb. In some embodiments, the distal portion 100 has a total length greater than about 60 mm. In some embodiments, the filaments are sheared using a device similar to a pole pruner. The ends may be trimmed transverse to the longitudinal axis or at an angle. The filaments may be trimmed individually, or two or more filaments (including all or substantially all of the filaments) may be trimmed at substantially the same time (e.g., with a single cutting stroke or motion). The cross-section of the ends of the filaments may depend at least partially on the trim angle and the angle of the braiding pattern at the trim point. The trimmed ends may be further treated or left as is.

[0561] FIG. 12A is a schematic perspective view of an example embodiment of a filament end treatment of a distal portion 6000 of a vascular treatment device. The distal portion 6000 may be the distal portion 100 of the device 10, 20, 30, or 40. The part of the distal portion 6000 shown in FIG. 12A is the distal neck 65, but could also or alternatively be a wide mouth distal section, a proximal neck, a wide mouth proximal section, etc. For illustration purposes, the distal portion 6000 includes 12 woven filaments 156, although end treatments described herein may be suitable for higher or lower quantities of filaments 156. FIG. 12B is a front elevational view of the filament end treatment of FIG. 12A. The filament end treatment illustrated in FIGS. 12A and 12B includes leaving the ends of the filaments 156 as is or untreated after they have been trimmed.

[0562] FIG. 12C is a schematic perspective view of another example embodiment of a filament end treatment of a distal portion 6100 of a vascular treatment device. The distal portion 6100 may be the distal portion 100 of the device 10, 20, 30, or 40. The part of the distal portion 6100 shown in FIG. 12C is the distal neck 65, but could also or alternatively be a wide mouth distal section, a proximal neck, a wide mouth proximal section, etc. For illustration purposes, the distal portion 6100 includes 12 woven filaments 156, although end treatments described herein may be suitable for higher or lower quantities of filaments 156. FIG. 12D is a front elevational

view of the filament end treatment of FIG. 12C. The filament end treatment illustrated in FIGS. 12C and 12D includes dip-coating or spray coating the distal neck 65 with a polymer. The polymer may comprise a biomedical polymer, for example silicone, polyurethane (e.g., Polyslix, available from Duke Extrusion of Santa Cruz, Calif.), polyethylene (e.g., Rexell®, available from Huntsman) including low density polyethylene (LDPE), linear low density polyethylene (LLDPE), medium density polyethylene (MDPE), and high density polyethylene (HDPE), fluoropolymers such as fluorinated ethylene propylene, PFA, MFA, PVDF, THV, ETFE, PCTFE, ECTFE (e.g., Teflon® FEP, available from DuPont), polypropylene, polyesters including polyethylene terephthalate (PET), PBT, PETG (e.g., Hytrel®, available from DuPont), PTFE, combination polymer compounds such as thermoplastic polyurethanes and polyether block amides (e.g., Propell™ available from Foster Corporation of Putnam, Conn.), polyether block amides (e.g. Pebax® available from Arkema of Colombes, France, PebaxSlix, available from Duke Extrusion of Santa Cruz, Calif.), polyether soft blocks coupled with polyester hard blocks vinyls such as PVC, PVDC, polyimides (e.g., polyimides available from MicroLumen of Oldsmar, Fla.), polyamides (e.g., Durethan, available from Bayer, Nylon 12, available from Duke Extrusion of Santa Cruz, Calif.), polycarbonate (e.g., Corethane™, available from Corvita Corp. of Miami, Fla.), styrenics such as PS, SAN, ABS, and HIPS, acetals such as copolymers or homopolymers, PLA, PGA, PLGA, PCL, polyorthoesters, polyanhydrides, and copolymers thereof, high temperature performance polymers such as PEEK, PES, PPS, PSU, LCP, combinations thereof, and the like. In some embodiments, the polymer may include a radiopaque material (e.g., particles of radiopaque material dispersed in the polymer). In some embodiments, masking a portion of the end section of the distal portion 6100 during dip coating or spray coating can inhibit polymer from depositing in the area of masking. For example, if the distal portion 6100 is dip coated or spray coated while still on the mandrel 170, the polymer may be inhibited from being deposited on the inside of the distal portion 6100, which can preserve the inner lumen and maintain an inner diameter of the distal portion 6100. In some embodiments, dip coating or spray coating prior to trimming the ends of the filaments 156 is also possible. In certain such embodiments, the polymer may maintain the position of the filaments 156 so that they are not frayed. The coated end section may then be trimmed and left as is or further coated. For example, the end section may be spray coated on the mandrel 170, trimmed, and then dip coated.

[0563] In some embodiments, coating may include coating radiopaque material (e.g., particles of iridium, platinum, tantalum, gold, palladium, tungsten, tin, silver, titanium, nickel, zirconium, rhenium, bismuth, molybdenum, combinations thereof, and the like, and/or other radiopaque agents such as barium sulfate, tungsten powder, bismuth subcarbonate, bismuth oxychloride, iodine containing agents such as iohexyl (e.g., Omnipaque™, available from Amersham Health, a division of GE Healthcare), etc.) The radiopaque material may be coated after the polymer, along with the polymer, and/or interspersed with the coating of the polymer. The filaments 156 may be cut in a manner that reduces fraying (e.g., laser cut) since a coating a frayed filament 156 may result in a coated but still frayed filament 156.

[0564] Referring again to FIGS. 12C and 12D, at least the distal end of the distal neck 65 is coated with polymer 6110.

In some embodiments, the polymer **6110** covers about 10% to about 75% (e.g., about 25% to about 50%) of the length of the distal neck **65**. In some embodiments, the polymer **6110** covers about 0.5 mm to about 3 mm (e.g., about 1 mm to about 2 mm) of the length of the distal neck **65**. More or less polymer **6110** can be used depending on the size of the distal portion **6100** and/or the distal neck **65**.

[0565] FIG. 12E is a schematic perspective view of yet another example embodiment of a filament end treatment of a distal portion **6200** of a vascular treatment device. The distal portion **6200** may be the distal portion **100** of the device **10**, **20**, **30**, or **40**. The part of the distal portion **6200** shown in FIG. 12E is the distal neck **65**, but could also or alternatively be a wide mouth distal section, a proximal neck, a wide mouth proximal section, etc. The filament end treatment illustrated in FIG. 12E includes coupling a radiopaque marker band **6210** to the distal end of the distal neck **65**. In some embodiments, the material of the radiopaque marker band may include metals or alloys, including but not limited to iridium, platinum, tantalum, gold, palladium, tungsten, tin, silver, titanium, nickel, zirconium, rhenium, bismuth, molybdenum, combinations thereof, and the like.

[0566] FIG. 12F is a schematic perspective view of still another example embodiment of a filament end treatment of a distal portion **6300** of a vascular treatment device. The distal portion **6300** may be the distal portion **100** of the device **10**, **20**, **30**, or **40**. The part of the distal portion **6300** shown in FIG. 12F is the distal neck **65**, but could also or alternatively be a wide mouth distal section, a proximal neck, a wide mouth proximal section, etc. The filament end treatment illustrated in FIG. 12F includes dip coating or spray coating with a polymer **6110** at least the distal end of the distal neck (e.g., as described with respect to FIGS. 12C and 12D) and coupling a radiopaque marker band **6210** to the distal end of the distal neck **65** (e.g., as described with respect to FIG. 12E).

[0567] Coating the ends of the distal portion **100** can inhibit the end from fraying and/or inhibit frayed ends from puncturing body tissue. The ends of the distal portion can be left loose, for example in embodiments in which the small size of the filaments allows them to be flexible enough to be unlikely to puncture tissue. Omission of a polymer tip (e.g., with no further processing or, for example, by coupling a radiopaque marker band without polymer) can allow the distal portion **100** to be sterilized using gamma radiation, which could damage polymers such as polyurethane and which is generally less expensive than chemical sterilization techniques such as ethylene oxide sterilization.

[0568] In some embodiments, the distal portion **100** includes a braided structure (e.g., produced by intertwining or interlacing two or more filaments diagonal or at an angle to the longitudinal or production axis of the distal portion **100**). Woven structures are not limited to those in which the filaments are oriented at about 90° angles to each other.

[0569] In some embodiments, the distal portion **100** includes a knitted structure (e.g., produced by interlocking a series of loops of the filaments to create the distal portion **100**). FIG. 13A is a photograph illustrating an example embodiment of a plurality of filaments **11830** being formed into an example biomedical textile structure **11825**. In contrast to some textile structures **158** described herein, the structure **11825** illustrated in FIG. 13A includes one or more filaments **11830** being transverse to the longitudinal axis, which can result in poor radial force, poor wall apposition, and poor clot capture, along with having poor filtering ability

(e.g., due to low porosity), but can allow longitudinal crowding to permit varying pore size during deployment. The size of pores of the textile structure **11825** may be substantially uniform over a large area. In some embodiments, at least a segment of the distal portion **100** includes knitting.

[0570] FIG. 13B is a photograph illustrating an example embodiment of a plurality of filaments **11845** being woven into another example biomedical textile structure **11835**. In contrast to some other textile structures **158** described herein, the structure **11835** illustrated in FIG. 13B is not formed as a cylinder, but is knitted as a sheet, here characterized by interlocking loops. The sheet **11835** may then be rolled into a cylinder and heat treated, mechanically fixed, etc. to impart the cylindrical structure, and the cylinder may then be wrapped around a bulbous mandrel, for example as described with respect to FIG. 10D. The sheet may be wrapped directly around a bulbous mandrel (e.g., without first being shape set into a cylinder), reducing manufacturing steps. A rolled sheet may include stray filaments along an entire length of the distal portion **100**, which may be advantageous for scraping some plaques or other such usages. The size of pores **11840** of the textile structure **11835** may be substantially uniform over a large area. Knitting into tubular shapes is also possible (e.g., weft knitting).

[0571] In some embodiments, after removal from a bulbous mandrel, the distal portion **100** does not include a crimping element around the necks or between the bulbs. In some embodiments, after removal from a bulbous mandrel, the distal portion **100** does not include a central wire or any other inner member such as an actuation member, other than the filaments used to form the shape-set textile structure (e.g., the bulbs and necks are hollow). In some embodiments, the distal portion **100** does not include radiopaque markers (e.g., marker bands), which can reduce a collapsed profile of the distal portion **100**. In some embodiments, at least one bulb of the distal portion **100** (e.g., the distal-most bulb) is larger than an aneurysm and/or a mouth of an aneurysm (e.g., in contrast to balls woven for the sole purpose of insertion into an aneurysm). In some embodiments, the distal portion is configured to capture a thrombus between undulations (e.g., between hills and valleys created by bulbs and necks and/or between crossing filaments) such that an interior volume of the distal portion **100** (e.g., radially inward of the necks and bulbs) is not configured to receive a thrombus.

[0572] Distal portions **100** are generally described herein as integral structures in which the same filaments form all of the bulbs and necks. In some embodiments, the distal portion **100** may include a plurality of woven textile structures coupled to each other. For example, each textile structure may include one bulb, a plurality of bulbs having the same size or different sizes, a plurality of bulbs having the same shape or different shapes, etc. Certain such embodiments can enable manufacturing of a plurality of woven textile structures at one time, and at a later time assembling distal portions **100** from selected woven textile structures.

[0573] The distal portions described above may also constitute an entire vascular or other body lumen treatment device. For example, the distal portions may be a deployable endoprosthesis or stent, part of a vascular treatment device such as an intermediate or proximal portion, etc. The endoprosthesis may be coupled to a proximal portion **200** or other device detachable joint (e.g., Guglielmi electrolytic detachment, mechanical detachment (e.g., as described herein), etc.).

[0574] The distal portion **100** can be coupled to a proximal portion **200** at a joint **300**, as described in further detail herein. In some embodiments, only the distal end of the distal portion **100** is coupled to the proximal portion at the joint **300**. In some embodiments, the proximal end of the distal portion **100** is not coupled, joined, affixed, adhered, bonded, etc. to the proximal portion **200**.

[0575] FIG. **14A** is a photograph of an example of a segment of an example embodiment of a proximal portion **200** of a vascular treatment device. FIG. **14B** is a photograph of another example segment of an example embodiment of a proximal portion **200** of a vascular treatment device. FIG. **12B** also includes a United States penny (\$0.01 or 1¢) to provide a rough, non-limiting, sizing of an example distal portion **200** and its kerfs **204**. The proximal portion **200** comprises a tubular structure **202** and a plurality of openings (slits, kerfs, cuts, incisions, etc.) **204**. FIG. **14A** also shows a heat impact puddle **207**, for example as described herein with respect to FIG. **17B**. As used herein, the term kerf shall be given its ordinary meaning and shall include slits, slots, and other openings that typically extend completely through a wall (e.g., sidewall), but may also partially extend into a wall (e.g., notches, grooves, etc.). In some embodiments, the tubular structure **202** comprises a hypotube (e.g., comprising stainless steel). In some embodiments, the proximal portion **200** comprises for example, platinum, titanium, nickel, chromium, cobalt, tantalum, tungsten, iron, manganese, molybdenum, and alloys thereof including nickel titanium (e.g., nitinol), nickel titanium niobium, chromium cobalt, copper aluminum nickel, iron manganese silicon, silver cadmium, gold cadmium, copper tin, copper zinc, copper zinc silicon, copper zinc aluminum, copper zinc tin, iron platinum, manganese copper, platinum alloys, cobalt nickel aluminum, cobalt nickel gallium, nickel iron gallium, titanium palladium, nickel manganese gallium, stainless steel, shape memory alloys, etc., polymers such as, for example, silicone, polyurethane (e.g., Polyslix, available from Duke Extrusion of Santa Cruz, Calif.), polyethylene (e.g., Rexell®, available from Huntsman) including low density polyethylene (LDPE), linear low density polyethylene (LLDPE), medium density polyethylene (MDPE), and high density polyethylene (HDPE), fluoropolymers such as fluorinated ethylene propylene, PFA, MFA, PVDF, THV, ETFE, PCTFE, ECTFE (e.g., Teflon® FEP, available from DuPont), polypropylene, polyesters including polyethylene terephthalate (PET), PBT, PETG (e.g., Hytrel®, available from DuPont), PTFE, combination polymer compounds such as thermoplastic polyurethanes and polyether block amides (e.g., Propell™ available from Foster Corporation of Putnam, Conn.), polyether block amides (e.g. Pebax® available from Arkema of Colombes, France, Pebaslix, available from Duke Extrusion of Santa Cruz, Calif.), polyether soft blocks coupled with polyester hard blocks vinyls such as PVC, PVDC, polyimides (e.g., polyimides available from MicroLumen of Oldsmar, Fla.), polyamides (e.g., Durethan, available from Bayer, Nylon 12, available from Duke Extrusion of Santa Cruz, Calif.), polycarbonate (e.g., Corethane™, available from Corvita Corp. of Miami, Fla.), styrenics such as PS, SAN, ABS, and HIPS, acetals such as copolymers or homopolymers, PLA, PGA, PLGA, PCL, polyorthoesters, polyhydrides, and copolymers thereof, high temperature performance polymers such as PEEK, PES, PPS, PSU, LCP, combinations thereof, and the like.

[0576] In some embodiments, the tubular structure **202** has an outer diameter between about 0.35 mm and about 0.65 mm (e.g., between about 0.4 mm and about 0.45 mm), between about 0.1 mm and about 0.5 mm (e.g., between about 0.25 mm and about 0.33 mm (e.g., about 0.0125 inches (approx. 0.318 mm))). In some embodiments, for example for use with peripheral vasculature, the tubular structure **202** has an outer diameter between about 0.5 mm and about 10 mm. In some embodiments, the tubular structure **202** has an inner diameter between about 0.2 mm and about 0.4 mm (e.g., about 0.25 mm). In some embodiments, the tubular structure **202** has a wall thickness  $t_w$ , or difference between the outer diameter (OD) and the inner diameter (ID) ( $OD-ID=t_w$ ) between about 0.001 inches (approx. 0.025 mm) and about 0.02 inches (approx. 0.5 mm).

[0577] In some embodiments, the tubular structure **202** has a length between about 2 feet (approx. 61 cm) and about 10 feet (approx. 305 cm) (e.g., about 7 feet (approx. 213 cm)). In some embodiments, the tubular structure **202** has a length between about 80 cm and about 210 cm, between about 80 cm and about 120 cm, between about 120 cm and about 150 cm, between about 150 cm and about 210 cm (e.g., about 180 cm). The length of the proximal portion **200** may at least partially depend on a length desired to reach somewhat proximate to a treatment site (e.g., proximal to the treatment site at least by the length of the distal portion **100**). For example, a length between about 80 cm and about 120 cm may be useful for treating peripheral vasculature, a length between about 120 cm and about 150 cm may be useful for treating coronary vasculature, and a length between about 180 cm and about 210 cm (e.g., about 180 cm) may be useful for treating neurovasculature. In some embodiments, the tubular structure **202** has a length greater than about 6 feet (approx. 183 cm).

[0578] At least some of the slits **204** include a first slit portion **204a** and a second slit portion **204b** with struts or stems or anchor points **206** between the first slit portion **204a** and the second slit portion **204b**. The struts **206** illustrated in FIGS. **12A** and **12B** are circumferentially between about 175° and about 185° (e.g., about 180°) apart and act as pivot points or anchor points for the tubular structure **202**. Other circumferential spacing is also possible, for example to provide more flexibility in one of the two degrees of freedom provided by that slit.

[0579] The slits **204** illustrated in FIGS. **12A** and **12B** are at an angle with respect to the longitudinal axis of the tubular structure **202**. In some embodiments, the angle is between about 95° and about 115° (e.g., the slits **204** are not transverse to the longitudinal axis). In some embodiments, the angle is about 90° (e.g., the slits are transverse to the longitudinal axis).

[0580] In some embodiments, forming the slits **204** includes laser cutting the tubular structure **202**. In certain such embodiments, the laser is programmed to cut all the way through a wall of the tubular structure **202**. The slit **204** may be thin enough that the laser can cut the entire slit **204** in one pass, or the slit **204** may be thick enough that the laser creates an outline of the slit **204**, which can remove the material between the outline. Other methods of forming the slits **204** are also possible (e.g., mechanical cutting, lithographic patterning, etc.).

[0581] FIG. **14C** is a schematic front elevational view of an example embodiment of a proximal portion **6605** of a vascular treatment device. As described herein, certain features of a cut pattern can inhibit or avoid pinch points such that in

some implementations the outer surface of the hypotube **6515** can remain uncovered. In some embodiments, the hypotube **6515** can include an outer coating **6520** due to being coated (e.g., dip-coated, spray coated, polymer extruded) with a polymer (e.g., to a thickness between about 0.0001 inches and about 0.0002 inches (approx. between about 0.0025 mm and about 0.0051 mm)). In some embodiments, the inner walls of the hypotube **6515** can include a coating **6310** (e.g., a hydrophilic coating or a hydrophobic coating) due to being coated (e.g., dip-coated, spray coated, polymer extruded) with a polymer (e.g., to a thickness between about 0.0001 inches and about 0.0002 inches (approx. between about 0.0025 mm and about 0.0051 mm)). The inner coating **6310** may be the same or different than the outer coating **6520**. In some embodiments, a parameter of a coating (e.g., material, thickness, durometer, etc.) may be varied to vary flexibility of the catheter. The catheter may include a working lumen **6305**. The variation may be instead of or in addition to (e.g., complementary to) variation in the cut pattern in the hypotube **6515**.

[0582] In some embodiments, a hypotube **6515** with a cut pattern as described herein may be used as a catheter (e.g., a microcatheter, a distal access microcatheter, a guide catheter) including an inner lumen **6505**. In some embodiments, a hypotube **6515** with a cut pattern as described herein, with or without other layers such as an inner coating and/or an outer coating, may be used for a portion of a catheter or any other tubular device that might benefit from an advantage provided thereby. For example, the hypotube **6515** may be used as a pusher wire for a stent deployment system. For another example, the hypotube **6515** may be used as an outer sheath for vascular treatment system. For further examples, the hypotube **6515** may be used as a tracheostomy tube, an endoscopy tube, a colonoscope, a laparoscope, a trans-esophageal echo (TEE) probe, a ventriculostomy catheter, a chest tube, a central venous catheter, a cooling catheter, etc.

[0583] FIG. 14D is a schematic side partial cross-sectional view of an example embodiment of a balloon catheter **6550**. The balloon catheter **6550** may be, for example, a balloon guide catheter or a distal access microcatheter including a balloon. The balloon catheter **6550** can be used, for example, for angioplasty (e.g., plain old balloon angioplasty (POBA), drug-coated balloon (DCB, DEB) angioplasty), atherectomy (e.g., if the balloon **6530** comprises a cutting balloon, expansion of an endoprosthesis (e.g., stent, valve), temporary flow arrest during mechanical thrombectomy, thrombus aspiration, proximal embolic protection device, other devices, etc.

[0584] The balloon catheter **6550** comprises a hypotube **6515** and a balloon **6530**. The hypotube **6515** includes a lumen **6505** configured to inflate and/or deflate the balloon **6530**. At least part of the length of the hypotube **6515** includes a cut pattern **6525**, for example the staggered and offset interspersed cut pattern as described herein, which can provide at least one of flexibility, torquability, etc. as described herein to the balloon catheter **6530**. The cut pattern may be angled or non-angled (e.g., as shown in FIG. 14D). Other variations of the cut patterns described herein are also possible. In the embodiment illustrated in FIG. 14D, the part of the hypotube **6515** radially inward of the balloon **6532** includes the cut pattern, and, for clarity in illustration, the parts of the hypotube **6515** proximal and distal to the balloon **6530** are illustrated without a cut pattern. Fluid (e.g., air, water, saline, etc.) used to inflate the balloon **6530** can traverse between the lumen **6505** and the interior volume of the balloon **6535** through the kerfs **6540** of the cut pattern. In

some embodiments, the part of the hypotube **6515** radially inward of the balloon **6532** includes a different cut pattern (e.g., configured to deliver fluid).

[0585] In the embodiment illustrated in FIG. 14D, the parts of the hypotube **6515** proximal and/or distal to the balloon **6530** include the cut pattern (not shown), an outer coating **6520**, and an inner coating **6510**. For example, parts proximal to the balloon **6528** may include the cut pattern and parts distal to the balloon **6536** may not include the cut pattern. The inner coating **6510** and/or the outer coating **6520** occlude the kerfs **6540**, which can allow the fluid to flow through the lumen **6505** to the part including the balloon **6530**. FIG. 14C may be a cross-section of the balloon catheter **6550** across the line 14C-14C in FIG. 14D, which is at a point along the hypotube **6515** that does not include kerfs. In some embodiments, the hypotube **6515** includes only one of the inner coating **6510** and the outer coating **6520**. In some embodiments, different parts of the hypotube **6515** proximal and distal to the balloon **6530** comprise one or both of the inner coating **6510** and the outer coating **6520**. In some embodiments, parts of the hypotube **6515** do not include the inner coating **6510** or the outer coating **6520**, but the kerfs **6540** are occluded by a polymer. For example, the polymer may be flush with the inner and/or outer surfaces of the hypotube **6515**. In embodiments in which the balloon **6530** is at the distal end of the hypotube **6515**, the parts of the hypotube **6515** distal to the balloon **6536** are short, do not exist, and/or do not include the cut pattern. In certain such embodiments, parts of the hypotube **6515** distal to the balloon **6536** do not include the cut pattern, the outer coating **6520**, and/or the inner coating **6510**. In some embodiments, parts of the hypotube **6515** without the cut pattern do not include the inner coating **6510** or the outer coating **6520**, for example because those parts do not include kerfs **6540**. The distal end of the hypotube **6515** may be occluded, for example by a polymer, solder, crimping, a plug, combinations thereof, and the like. In some embodiments, the distal end of the balloon catheter **6536** comprises an atraumatic polymer tip **6538** including a tapered inner diameter. In certain such embodiments, a second catheter (e.g., a distal access catheter or a microcatheter) and/or a third catheter (e.g., a distal access catheter or a microcatheter) may be inserted through a working lumen created by the hypotube **6515**. The outer diameter (e.g., 6 Fr) of the second catheter and/or the third catheter is substantially similar to or at least as large as the inner diameter (e.g., 6 Fr) of the polymer tip, which can create an arcuate seal of the working lumen, which can allow inflation of the balloon **6530** without permanent occlusion. A proximal segment of the hypotube **6515** where torque applied by an operator of the balloon catheter **6550** is the greatest may be configured to reduce kinking, for example comprising a strain relief (e.g., polymer sheath that may be the same as or different to the outer coating **6520**), a braided structure, combinations thereof, and the like.

[0586] The hypotube **6515** can comprise hypotube materials, dimensions, etc. described herein. Portions of the balloon catheter **6550** (e.g., the balloon **6530**, the inner coating **6510**, the outer coating **6520**) may comprise a biomedical polymer, for example, silicone, polyurethane (e.g., Polyslix, available from Duke Extrusion of Santa Cruz, Calif.), polyethylene (e.g., Rexell®, available from Huntsman) including low density polyethylene (LDPE), linear low density polyethylene (LLDPE), medium density polyethylene (MDPE), and high density polyethylene (HDPE), fluoropolymers such as fluori-



nated ethylene propylene, PFA, MFA, PVDF, THV, ETFE, PCTFE, ECTFE (e.g., Teflon® FEP, available from DuPont), polypropylene, polyesters including polyethylene terephthalate (PET), PBT, PETG (e.g., Hytrel®, available from DuPont), PTFE, combination polymer compounds such as thermoplastic polyurethanes and polyether block amides (e.g., Propell™ available from Foster Corporation of Putnam, Conn.), polyether block amides (e.g. Pebax® available from Arkema of Colombes, France, PebaxSlix, available from Duke Extrusion of Santa Cruz, Calif.), polyether soft blocks coupled with polyester hard blocks vinyls such as PVC, PVDC, polyimides (e.g., polyimides available from MicroLumen of Oldsmar, Fla.), polyamides (e.g., Durethan, available from Bayer, Nylon 12, available from Duke Extrusion of Santa Cruz, Calif.), polycarbonate (e.g., Corethane™, available from Corvita Corp. of Miami, Fla.), styrenics such as PS, SAN, ABS, and HIPS, acetals such as copolymers or homopolymers, PLA, PGA, PLGA, PCL, polyorthoesters, polyanhydrides, and copolymers thereof, high temperature performance polymers such as PEEK, PES, PPS, PSU, LCP, combinations thereof, and the like. In some embodiments, the balloon catheter 6550 comprises radiopaque markers 6542, 6548, proximate to the proximal and distal ends of the balloon 6530. For example, as illustrated in FIG. 14D, the radiopaque markers 6542, 6544, 6546, 6548, comprise filled in kerfs (e.g., as described in further detail with respect to FIG. 19B). In the embodiment illustrated in FIG. 14D, the balloon catheter 6530 comprises a plurality of radiopaque markers 6549 at regular intervals, which may help to measure clot length, degree or length of a stenosis in a vessel, diameter of a vessel, dimensions of an aneurysm arising from a vessel (e.g., the mouth of the aneurysm), etc. for intra-operative decision making on device selection.

[0587] FIG. 15A is a schematic diagram illustrating an example embodiment of a cut pattern. The pattern includes two interspersed patterns: Pattern A, indicated by the shaded blocks, and Pattern B, indicated by the unshaded blocks. FIG. 15B is a schematic diagram illustrating an example embodiment of a portion of a cut pattern, Pattern A illustrated in FIG. 15A without Pattern B. FIG. 15C is a schematic diagram illustrating another example embodiment of a portion of a cut pattern, Pattern B illustrated in FIG. 15A without Pattern A.

[0588] Pattern A includes a series of arcuate slits 210 (including the slit halves 210a, 210b), 212 (including the slit halves 212a, 212b), 214 (including the slit halves 214a, 214b), 216 (including the slit halves 216a, 216b), etc. Pattern B includes a series of arcuate slits 220 (including the slit halves 220a, 220b), 222 (including the slit halves 222a, 222b), 224 (including the slit halves 224a, 224b), 226 (including the slit halves 226a, 226b), 228 (including the slit halves 228a, 228b), etc. The slits 210, 220, et al. are not fully arcuate) (360°, which would cut the tubular structure 202 in two pieces, but are interrupted by two stems or struts or anchor points (e.g., the stems 221a, 221b between the slit halves 220a, 220b, the stems 211a, 211b between the slit halves 210a, 210b) circumferentially spaced about 180° apart by the two halves of an arcuate slit. When the slits 210 are perpendicular to the longitudinal axis, a row is defined by slit halves 210a, 210b around that circumference. When the slits 210 are angled other than perpendicular to the longitudinal axis, a row is defined by slit halves 210a, 210b and stems 211a, 211b therebetween that have traversed a full circumference of the tubular structure 202.

[0589] The arrows 310 indicate that the view is exploded outward, or that if this is a laser cut sheet that is rolled into a tube by bending the left and right sides into the page such that the pattern shown is for an outer circumference. The inside of the tubular structure 202 has a circumference  $c_i = \pi d_i$ , where  $d_i$  is the inner diameter of the tubular structure 202. The outside of the tubular structure 202 has a circumference  $c_o = \pi d_o$ , where  $d_o$  is the outer diameter of the tubular structure 202. A ratio of the circumferential length of a slit 204 to the circumference  $c_o$  can be calculated. Parameters of the slits 204 can be represented as absolute values (e.g., in inches or mm) or as a percentage of  $c_i$  or  $c_o$ . Once the ratio between  $c_i$  and  $c_o$  is known, values related to the proximal portion 200 that are known for  $c_o$  (e.g., as may be provided to a manufacturer) may be calculated and/or derived therefrom with reference to  $c_i$ , and vice versa.

[0590] In some embodiments, the slit 210, for example, includes one slit and one stem. In some embodiments, the slit 210 includes two slit portions 210a, 210b (e.g., for example as described in detail herein). In some embodiments, the slit 210 includes four slit portions (e.g., with stems spaced about 90° apart). Other numbers of slit portions and stems are also possible.

[0591] Anchor points that are substantially diametrically opposed along a circumference of the tubular structure 202 (e.g., two anchor points 211a, 211b spaced about 180° apart) can allow a freedom of flexibility about the anchor points. Anchor points that are not substantially diametrically opposed are also possible, which can create uneven freedom of movement about the anchor points to create a higher degree of freedom of flexibility in one direction and a lower degree of freedom of flexibility in the opposite direction. The anchor points can inhibit or prevent compression of the proximal portion 200 in the direction in which they extend, but can support freedom of movement in a direction 90° away from the location of the anchor points, the direction of freedom.

[0592] In some embodiments, longitudinally adjacent stems are generally not longitudinally aligned (parallel along the longitudinal axis of the tubular structure 202), which could result in pinching at any point along the proximal portion 200, similar to the pinching that may be caused by a continuous coil or spiral cut. Rather, stems in adjacent rows of Pattern A are offset by a circumferential distance  $O_A$  (FIG. 15B) and stems in adjacent rows of Pattern B are offset in the opposite direction by a circumferential distance  $O_B$  (FIG. 15C). Stems in adjacent rows of the overall cut pattern are staggered by a circumferential distance  $S$ . Staggering and/or offsetting the circumferential positioning of the stems can increase the number of degrees of motion and/or increase safety by reducing or eliminating the possibility of pinching. In embodiments comprising two patterns (e.g., Patterns A and B), both patterns can be offset in a clockwise direction, both patterns can be offset in a counterclockwise direction, or one pattern can be offset in a clockwise direction and the other pattern can progress in a counterclockwise direction (e.g., as illustrated in FIG. 15A).

[0593] In some embodiments, the value of the offset  $O_A$  (and  $O_B$ ) is proportional to the circumferential length 230 of the slit half between the stems, also called the kerf length. The ratio of the offset to the circumferential length of the slit half may determine how quickly the stems are aligned longitudinally or, colloquially, how quickly a particular slit or row repeats itself along the tubular structure 202. For example, if the ratio is 1/8, then the first, ninth, seventeenth, etc. slits would

be the same, the second, tenth, eighteenth, etc. slits would be the same, and so on. In some embodiments, a row of a pattern may repeat between about every 2 rows and about every 20 rows. Higher repetition may be desired, but may be limited by geometry, manufacturing tolerances, etc.

**[0594]** Referring again to FIG. 15A, the stems **211a**, **211b** in Pattern A and the stems **221a**, **221b** in Pattern B do not start out aligned and are staggered by a value  $S$ . In some embodiments, the stems **211a**, **211b** in Pattern A and the stems **221a**, **221b** in Pattern B are never aligned along the length of the tubular structure **202**. In some embodiments, the stagger  $S$  between the stems **211a**, **211b** in the first row of Pattern A and the stems **221a**, **221b** in the first row of Pattern B can help inhibit alignment of the stems of Patterns A and B if related to the length **230** of the slit halves. For example, an initial stagger  $S$  that is about 40% of the length of the slit halves can reduce or minimize the incidence of longitudinally adjacent stems of Patterns A and B being longitudinally aligned.

**[0595]** FIG. 15D is a schematic diagram illustrating an example embodiment of staggered interspersed cut patterns. Patterns A and B are interspersed. The right end of the slit **210a** of Pattern A is staggered from the right end of the slit **220a** of Pattern B by a value  $S$ . The right end of the slit **210a** of Pattern A is also offset from the right end of the slit **212a** of Pattern A by a value  $O_A$ . The left end of the slit **220a** of Pattern B is offset from the left end of the slit **222a** of Pattern B by a value  $O_B$ . In some embodiments, the number of cut patterns that are interspersed is between 1 (e.g., the same cut pattern without any interspersing) and 5 (e.g., 2 as described in detail herein). A proximal portion **200** including two interspersed patterns can increase the number of degrees of freedom of rotation or movement, which can help with navigation through narrow vessels. The interspersing can be the entire length of the proximal portion **200** or sections thereof. In some embodiments, two cut patterns are interspersed for a first length of the proximal portion **200** and two cut patterns (one or both of which may be different than the two cut patterns along the first length) for a second length of the proximal portion **200**, etc.

**[0596]** FIG. 15E is a schematic diagram illustrating an example embodiment of staggered interspersed offset cut patterns. The left and right sides of FIG. 15E show the same cuts, but shaded differently to highlight the various cut patterns. On the left side, Pattern A is shown in dashed outline without shading and Pattern B is shown in solid outline and with shading. The right end of the slit **210a** is offset from the right end of the slit **212a** by a value of  $O_A$ . The right end of the slit **212a** is offset from the right end of the slit **214a** by a value of  $O_A$ . The right end of the slit **214a** is offset from the right end of the slit **216a** by a value of  $O_A$ . The right end of the slit **210a** is offset from the right end of the slit **214a** by a value of  $2 \times O_A$ . The right end of the slit **210a** is offset from the right end of the slit **216a** by a value of  $3 \times O_A$ . The offset  $O_A$  is to the right, as indicated by the arrow **242**.

**[0597]** On the right side, Pattern B is shown in dashed outline without shading and Pattern A is shown in solid outline and with shading. The left end of the slit **220a** is offset from the left end of the slit **222a** by a value of  $O_B$ . The left end of the slit **222a** is offset from the left end of the slit **224a** by a value of  $O_B$ . The left end of the slit **224a** is offset from the left end of the slit **226a** by a value of  $O_B$ . The left end of the slit **226a** is offset from the left end of the slit **228a** by a value of  $O_B$ . The left end of the slit **220a** is offset from the left end of the slit **224a** by a value of  $2 \times O_B$ . The left end of the slit **220a**

is offset from the left end of the slit **226a** by a value of  $3 \times O_B$ . The left end of the slit **220a** is offset from the left end of the slit **228a** by a value of  $4 \times O_B$ . The offset  $O_B$  is to the left, as indicated by the arrow **244**. The offset  $O_B$  may be considered negative in comparison to the offset  $O_A$  because it is in the opposite direction.

**[0598]** The offset  $O_A$  is different than the offset  $O_B$ , which may be easily seen by the different slopes of the lines **242**, **244**, or the intra-pattern anchor point stagger angle. Referring also again to FIG. 15D, the offset  $O_A$ , offset  $O_B$ , and stagger  $S$  may at least partially influence the repetition a single row or frequency of rows having longitudinally aligned stems.

**[0599]** Although some patterns illustrated herein are interspersed by having alternating slits of a first pattern and a second pattern (e.g., Pattern A slit, Pattern B slit, Pattern A slit, Pattern B slit, etc.), slit patterns may be interspersed in other ways. For example, two slits from each of two patterns may alternate (e.g., Pattern A slit, Pattern A slit, Pattern B slit, Pattern B slit, Pattern A slit, Pattern A slit, Pattern B slit, Pattern B slit, etc.). For another example, one slit of a first pattern may alternate with two slits of a second pattern (e.g., Pattern A slit, Pattern B slit, Pattern B slit, Pattern A slit, Pattern B slit, Pattern B slit, etc.). For yet another example, slits from three or more patterns may be interspersed (e.g., Pattern A slit, Pattern B slit, Pattern C slit, Pattern A slit, etc.).

**[0600]** In some embodiments, the proximal portion **200** includes a plurality of longitudinally-spaced slits **204** including a first slit **220**, a second slit **210**, a third slit **222**, and a fourth slit **212**. The slit **220** includes a first slit half **220a** and a second slit half **220b**. A first stem **221a** is between the first slit half **220a** and the second slit half **220b**, and a second stem **221b** is between the first slit half **220a** and the second slit half **220b** and about circumferentially about  $180^\circ$  from the first stem **221b**. The slit **210** includes a first slit half **210a** and a second slit half **210b**. A first stem **211a** is between the first slit half **210a** and the second slit half **210b**, and a second stem **211b** is between the first slit half **210a** and the second slit half **210b** and about circumferentially about  $180^\circ$  from the first stem **211b**. The slit **222** includes a first slit half **222a** and a second slit half **222b**. A first stem **223a** is between the first slit half **222a** and the second slit half **222b**, and a second stem **223b** is between the first slit half **222a** and the second slit half **222b** and about circumferentially about  $180^\circ$  from the first stem **223b**. The slit **212** includes a first slit half **212a** and a second slit half **212b**. A first stem **213a** is between the first slit half **212a** and the second slit half **212b**, and a second stem **213b** is between the first slit half **212a** and the second slit half **212b** and about circumferentially about  $180^\circ$  from the first stem **213b**. The stems **221a**, **221b** are each circumferentially offset from the stems **211a**, **211b**, the stems **223a**, **223b**, and the stems **213a**, **213b**. The stems **211a**, **211b** are each circumferentially offset from the stems **221a**, **221b**, the stems **223a**, **223b**, and the stems **213a**, **213b**. The stems **223a**, **223b** are each circumferentially offset from the stems **221a**, **221b**, the stems **211a**, **211b**, and the stems **213a**, **213b**. The stems **213a**, **213b** are each circumferentially offset from the stems **221a**, **221b**, the stems **211a**, **211b**, and the stems **223a**, **223b**. Within a three ring window or a four ring window, none of the stems are circumferentially aligned. Other larger windows without circumferential stem alignment are also possible (e.g., between about 3 rings and about 100 rings, between about 3 rings and about 50 rings, between about 3 rings and about 25 rings), for example depending on offset and stagger values.

**[0601]** FIG. 16A is a schematic diagram illustrating an example embodiment of an angled pattern including sharp edges. The pattern is angled from the orthogonal, indicated by the dashed line, by the angle **250**. The angle **250** may be between about  $5^\circ$  and about  $25^\circ$ . The angle **250** may be between about  $-5^\circ$  and about  $-25^\circ$  (e.g., angled in the opposite direction). The pattern(s) include slits having sharp edges, for example ends with  $90^\circ$  corners. Other sharp ends are also possible (e.g., trapezoidal slits with corners more or less than  $90^\circ$ ). Sharp edges may provide greater slit end robustness, but may produce cilia, or minute hair-like follicles of material, that can result from rerouting a cutter (e.g., a laser cutter) at sharp corners. Cilia can be removed by a process like electropolishing, but that can increase cost and risk unremoved cilia, which could be fatal if herniated into vasculature.

**[0602]** FIG. 16B is a schematic diagram illustrating an example embodiment of an angled pattern including rounded edges. The pattern is angled from the orthogonal, indicated by the dashed line, by the angle **250**. The angle **250** may be between about  $5^\circ$  and about  $25^\circ$ . The angle **250** may be between about  $-5^\circ$  and about  $-25^\circ$  (e.g., angled in the opposite direction). The pattern(s) include slits having rounded edges, for example arcuate or rounded (e.g., semicircular, rounded corners) ends. Rounded slits may reduce or eliminate the incidence of cilia. Reduced or eliminated cilia can eliminate cilia-removal processes, reducing manufacturing costs. Reduced or eliminated cilia can increase safety of the device by reducing or eliminating the chances of a cilium herniating into vasculature. Rounded slits may reduce or minimize fracture points.

**[0603]** FIG. 16C is a schematic diagram illustrating an example embodiment of interspersed offset horizontal patterns including sharp edges. The left and right sides of FIG. 16C show the same cuts, but shaded differently to highlight the various cut patterns. Similar to FIG. 15E, described in detail above, the left side of FIG. 16C shows an arrow **242** connecting the right sides of a first pattern including a first offset and the right side of FIG. 16C shows an arrow **244** connecting the left sides of a second pattern including a second offset, the first pattern and the second pattern interspersed with and staggered from each other. The patterns in FIG. 16C are shown horizontal, but could be angled, for example as illustrated in FIG. 16A.

**[0604]** FIG. 16D is a schematic diagram illustrating an example embodiment of interspersed offset horizontal patterns including rounded edges. The left and right sides of FIG. 16D show the same cuts, but shaded differently to highlight the various cut patterns. Similar to FIG. 15E, described in detail above, the left side of FIG. 16D shows an arrow **242** connecting the right sides of a first pattern including a first offset and the right side of FIG. 16D shows an arrow **244** connecting the left sides of a second pattern including a second offset, the first pattern and the second pattern interspersed with and staggered from each other. The patterns in FIG. 16D are shown horizontal, but could be angled, for example as illustrated in FIG. 16C.

**[0605]** FIG. 16E is a schematic diagram illustrating an example embodiment of slits and stems along the length of an example embodiment of a proximal portion **270**. Above the dashed line, one of two stems of a first pattern in a numbered slit row is shaded for easier visualization of the repetition of the row. The shaded stem or anchor point in row 1 is the same as the shaded stem or anchor point in row 11, showing that the

stems repeat every 10th row. As described above, the ratio of the offset to the circumferential length of the slit half may determine how quickly the stems are aligned longitudinally or, colloquially, how quickly a particular slit repeats itself along the tubular member. For example, in the example illustrated in the top half of FIG. 16E, such a ratio may be  $\frac{1}{10}$  so that the first, eleventh, etc. slits and stems would be the same, the second, twelfth, etc. slits and stems would be the same, and so on. The pattern for which the stems are shaded is interspersed with a second pattern so that the actual repetition rate is about half of the ratio. For example, nine rows of the second pattern are between the first and eleventh row of the first pattern, so there are actually nineteen rows of slits and stems before the repetition of a row.

**[0606]** Below the dashed line in FIG. 16E, one of two stems of a second pattern in a numbered slit row is shaded for easier visualization of the repetition of the row. The shaded stem in row 1 is the same as the shaded stem in row 11, showing that the stems repeat every 10th row. As described above, the ratio of the offset to the circumferential length of the slit half may determine how quickly the stems are aligned longitudinally or, colloquially, how quickly a particular slit repeats itself along the tubular member. For example, in the example illustrated in the bottom half of FIG. 16E, such a ratio may be  $\frac{1}{10}$  so that the first, eleventh, etc. slits and stems would be the same, the second, twelfth, etc. slits and stems would be the same, and so on. The pattern for which the stems are shaded is interspersed with the first pattern so that the actual repetition rate is about half of the ratio. For example, nine rows of the first pattern are between the first and eleventh row of the second pattern, so there are actually nineteen rows of slits and stems before the repetition of a row.

**[0607]** FIG. 16F is a schematic diagram illustrating another example embodiment of slits and stems along the length of an example embodiment of a proximal portion **272**. One of two stems of each of two interspersed and staggered offset patterns is shaded for easier visualization of the pattern. Arrows are also provided connecting similar points of the patterns for easier visualization of the pattern. In the section of the proximal portion **272** illustrated in FIG. 16F, neither of the patterns repeats, and the patterns do not have any rows that match. The section of the proximal portion **272**, which has twenty rows, has twenty degrees of freedom of movement, one at each row. In contrast, slotted hypotubes in which stems are offset by  $90^\circ$  every row such that every other row matches have only two degrees of freedom along the entire length of the hypotube. Fewer degrees of freedom generally causes less flexibility and/or maneuverability.

**[0608]** The flexibility of the proximal portion **200** can vary along at least a section of the length of the proximal portion **200**, for example by varying one or more parameter (e.g., angle of cut relative to longitudinal axis, slit width, pitch or spacing between slits, ratio of slit width to pitch, stem offset, ratio of stem offset to slit half length, pattern stagger, etc.). The variation can be in discrete longitudinal segments, gradual, or combinations thereof. Gradual transition between parameters, for example pitch, can inhibit or avoid kink points.

**[0609]** FIG. 17A is a schematic diagram illustrating an example embodiment of a laser cutting system **10100**. The laser cutting system **10100** may include customized components that can be used to laser cut the interspersed patterns of rows of kerfs in thin-walled tubes over relatively long lengths to form the proximal portions **200** of device **10**, **20**, **30** or **40**,

for example compared to stents are only few inches long at most. The laser cutting system **10100** comprises a cooling system **10105** configured to cool the laser excitation source **10110** and/or the laser media or laser generating medium **10120**.

**[0610]** In some embodiments, the laser cutting system **10100** includes a yttrium aluminum garnet ( $Y_3Al_5O_{12}$ , YAG) laser excitation source **10110**, for example instead of a carbon dioxide ( $CO_2$ ) laser source for laser cutting a proximal portion **200**. The YAG laser utilizes infrared wavelength in the  $1.064\ \mu m$  wavelength for laser cutting compared to a  $CO_2$  laser that utilizes infrared wavelength in the  $10.64\ \mu m$  wavelength for laser cutting. Compared to a  $CO_2$  laser, the beam from the YAG laser has a wavelength that is ten times smaller for laser cutting complex interspersed smaller patterns and can create smaller heat impact puddles and heat affected zones, which can reduce the risk of fissures or fractures in the stems of the laser cut hypotubes. The heat impact puddle is the initial point of contact of the laser beam on the hypotube during the laser cutting process. The heat affected zone is the area of the base material of the hypotube surrounding the initial point of contact of the laser beam, which can have its microstructure and properties altered because of heat intensive laser cutting operations of the laser beam.

**[0611]** In some embodiments, a relatively smaller heat impact puddle and heat impact zone can be achieved by utilizing an infrared wavelength between about  $1.060\ \mu m$  and about  $1.070\ \mu m$ , which can generate a smaller laser beam, which can reduce the risk of fissures or fractures during laser cutting small patterns on the proximal portion **200**. In some embodiments, a ytterbium ( $Yb^{3+}$ ) doped YAG laser or a neodymium ( $Nd^{3+}$ ) doped YAG laser can help generate infrared wavelengths between about  $1.060\ \mu m$  and about  $1.070\ \mu m$ , for example compared to an erbium ( $Er^{3+}$ ) doped YAG laser.

**[0612]** The laser cutting system **10100** illustrated in FIG. **17A** comprises a laser excitation source **10110** that can help excite the ions in the laser medium or crystal in the laser medium or laser generating medium **10120**. Excitation of the  $Yb^{3+}$  or  $Nd^{3+}$  ions by the laser excitation source **10110** can result in specific energy level transitions for the  $Yb^{3+}$  or  $Nd^{3+}$  ions, and the resulting energy level transitions from a higher or upper energy level to a lower energy level can create specific infrared wavelengths between about  $1.060\ \mu m$  and about  $1.070\ \mu m$ , which can generate a relatively smaller laser beam with relatively smaller heat impact puddles and heat affected zones.

**[0613]** In some embodiments in which the laser cutting system **10100** includes a laser medium **10120** that is ytterbium-doped yttrium aluminum garnet ( $Yb:Y_3Al_5O_{12}$ ), the laser excitation source **10110** can excite the  $Yb^{3+}$  ions, which can result in ytterbium ion energy level transitions from the upper energy level or the upper Stark level manifold  ${}^2F_{5/2}$  to the lower energy level or lower Stark level manifold  ${}^2F_{7/2}$ , which can generate a wavelength of about  $1.060\ \mu m$  in the infrared wavelength range, which can generate relatively smaller heat impact puddles and heat affected zones.

**[0614]** In some embodiments in which the laser cutting system **10100** includes a laser medium **10120** that is neodymium-doped yttrium aluminum garnet ( $Nd:Y_3Al_5O_{12}$ ), the laser excitation source **10110** can excite the  $Nd^{3+}$  ions, which can result in neodymium ion energy level transitions from the upper energy level or the upper Stark level manifold  ${}^4F_{3/2}$  to the lower energy level or lower Stark level manifold  ${}^4I_{11/2}$ ,

which can generate a wavelength of about  $1.060\ \mu m$  in the infrared wavelength range, which can generate relatively smaller heat impact puddles and heat affected zones.

**[0615]** Referring again to FIG. **17A**, the infrared wavelength laser beam that is generated by exciting the ions of the laser medium **10120** may be reflected across a plurality of mirrors and lenses, for example a rear mirror **10115** and a front mirror **10125**. In some embodiments, the concentrated laser beam can be focused onto the hypotube of the proximal portion **200** via a lens **10145**.

**[0616]** Heat may be generated during the process of the laser beam impacting the hypotube of the proximal portion **200**. In some embodiments, an external gas (e.g., air) based cooling system **10130** for the laser beam can reduce the heat impact puddle and the heat affected zone, and may help remove external slag **10155** generated during the laser cutting process, which may be collected in an external slag collecting device **10150**. The external gas cooling system **10130** includes a supply of gas that can flow into a laser nozzle in the direction indicated by the **10140**. An external gas inflow valve **10135** can regulate the gas that circulates into the laser nozzle to reduce the heat impact puddle and the heat impact zone.

**[0617]** In some embodiments, the hypotube of the proximal portion **200** that is being laser cut may be carefully handled to reduce the chance of kinking or fracturing the hypotube **200**. The laser cutting system **10100** includes a hypotube collector device **10200** including a spiral collector configured to wind the hypotube of the proximal portion **200** after laser cutting, which can inhibit kinking or otherwise damaging the laser-cut hypotube **200**. The external gas cooling system **10130** can provide cooling to the hypotube collector device **10200**. The external gas cooling system **10130** includes a supply of gas that can flow into the hypotube collector device **10200**. An external gas inflow valve **10205** can regulate the gas that circulates into the hypotube collector device **10200**, which can cool the laser-cut hypotube **200** and reducing the heat affected zone. The gas used for the external cooling system **10130** can include, for example, ambient air or inert gas. In some embodiments, the temperature of the gas is at about ambient temperature (e.g., between about  $20^\circ C$ . and about  $25^\circ C$ .) and the external gas cooling is continued for all or a portion of the duration of the laser cutting process.

**[0618]** In the laser cutting system **10100** illustrated in FIG. **17A**, the hypotube of the proximal portion **200** is held in position by a bushing **10160** configured to inhibit motion of the hypotube **200** prior to the laser beam impacting the hypotube **200**, one or more collets **10165** configured to reduce sag of the relatively long hypotube **200** and/or to maintain adequate tension  $F_t$  on the hypotube **200** as the hypotube **200** is being advanced towards the laser beam, and a hypotube clamp that is part of a motor **10175** and hypotube dispenser **10180** that hold the hypotube **200** and help advance the hypotube **200** forward towards the laser beam.

**[0619]** In some embodiments, the system **10100** includes an external water inlet regulator device **10190** including a pressure valve **10197** configured to pump water through a series of water injection tubes **10195** and a constrictive water inlet gate **10187** configured to inject water into the inner lumen of the hypotube **200**. The external water inlet regulator device **10190** injects water into the hypotube **200** at a certain velocity, which can assist with removal of the slag **10155** that is generated during the laser cutting process by removing the slag **10155** before the slag **10155** has time to sediment and adhere to the inner lumen of the hypotube **200**. The external

water inlet regulator device **10190** can assist with cooling the hypotube **200** during the laser cutting process and reduce the size of the heat impact puddle and/or the size of the heat affected zone. The laser cutting system **10100** may include a laser controller box **10170** configured to controls one, some, or all the processes within laser cutting system **10100** (e.g., shown in communication with the water inlet regulator device **10190**).

[**0620**] In some embodiments, a proximal portion **200** comprises a hypotube including the Patterns A and B described herein with a variable pitch between slits, which increases flexibility from proximal to distal. The Patterns A and B may be formed, for example, by laser cutting using, for example, the system **10100**. Each slit has a width along the longitudinal axis (which may take into account an angle of the kerf) of about 0.001 inches (approx. 0.025 mm). The longitudinal slit widths may have a tolerance of  $\pm 0.0002$  inches (approx. 0.005 mm). Longitudinally thicker and thinner slits are also possible. For example, a thicker slit may provide flexibility for thicker hypotubes. For another example, a thinner slit may provide strength for thinner hypotubes. The kerf width may be greater than the width of a laser beam used to cut the kerf, which can inhibit formation of a heat impact puddle on an edge of the kerf because the initial heat impact puddle can be in a middle of the kerf and removed upon finishing cutting the kerf. The hypotube may have an outer diameter of about 0.0125 inches (approx. 0.318 mm) and an inner diameter between about 0.001 inches (approx. 0.025 mm) and about 0.0011 inches (approx. 0.028 mm).

[**0621**] In some embodiments, a ratio of a width of a kerf along a longitudinal axis and a circumferential width of a strut at least partially defined by the kerf is between about 1:1 and about 2:1. For example, the kerf width may be about 0.003 inches (approx. 0.076 mm) and the strut width may be about 0.003 inches (approx. 0.076 mm) such that the ratio is 1:1.

[**0622**] FIG. 17B is a schematic diagram illustrating an example embodiment of a cut design of a slit **6400**. A heat impact puddle **6405** is the initial point of contact of the laser beam on the hypotube during the process of cutting the kerf **6400** with the laser. The path of the laser beam is a straight line **6415** and the heat impact puddle **6405** is formed at the edge of the kerf **6400**. The heat affected zone is the area in which the microstructure and/or properties of the base material of the hypotube is altered by the laser beam. The diameter **6410** of the heat impact puddle **6405** is larger than the width **6420** of the kerf **6400** such that the heat affected zone around the heat impact puddle **6405** remains part of the cut pattern, which can make the struts between the kerfs more prone to fractures or fissures **6430**. The circumferential length **6440** of the kerf **6400** is larger than the intended circumferential length of the kerf **6400** due to the heat impact puddle **6405** being on the edge of the kerf **6400**.

[**0623**] In some embodiments, the diameter **6410** of the heat impact puddle **6405** can be larger than a width **6420** of the kerf **6400** without damaging the structural integrity of the struts proximate to the heat impact puddle **6405**. Certain patterns described herein include struts and slits that are close to each other along with the complexity of the interspersed laser cut patterns in a thin-walled hypotube over the relatively long length of the proximal portion **200** compared to, for example, laser-cut stents, and fractures and fissures may be inhibited or prevented if the laser intensity and the laser beam angle are set such that the diameter of the heat impact puddle **6405** does not exceed about 120% of the width **6420** of the kerf **6400**. FIG.

**17C** is a schematic diagram illustrating an example embodiment of an interspersed offset horizontal pattern **6500** including slits **6400** and heat impact puddles **6405**. FIG. 17C shows the possible proximity of the kerfs **6400** with heat impact puddles **6405** and fractures **6430**.

[**0624**] FIG. 17D is a schematic diagram illustrating another example embodiment of a cut design of a slit **6600**. In some embodiments, the width **6420** and length **6435** of the kerf **6600** may be greater than the width of a laser beam used to cut the kerf **6600**, which can inhibit formation of a heat impact puddle on an edge of the kerf **6600**. In the embodiment illustrated in FIG. 17D, the path **6415** of the laser beam starts with the heat impact puddle **6405** in a central or intermediate or middle of the kerf **6600** and travels up to an edge of the kerf **6600** and then along the edges of the kerf **6600**, surrounding the heat impact puddle **6405**, such that the heat impact puddle and the heat affected zone can be removed or substantially removed by the cutting process. In certain such embodiments, the removal of the heat impact puddle **6405** and the heat affected zone can maintain the structural integrity of the struts and/or inhibit or prevent formation of fractures or fissures.

[**0625**] FIG. 17E is a schematic diagram illustrating yet another example embodiment of a cut design of a slit **6700**. In some embodiments, the width **6420** and length **6435** of the kerf **6700** may be greater than the width of a laser beam used to cut the kerf **6700**, which can allow the heat impact puddle **3405** to be within the edges of the slit **6700**. In the embodiment illustrated in FIG. 17E, the path **6415** of the laser beam starts with the heat impact puddle **6405** in a central or intermediate or middle of the kerf **6700** and travels diagonally to the upper left corner of the kerf **6700** and then along the edges of the kerf **6700**, surrounding the heat impact puddle **6405**, such that the heat impact puddle and the heat affected zone can be removed or substantially removed by the cutting process. In certain such embodiments, the removal of the heat impact puddle **6405** and the heat affected zone can maintain the structural integrity of the struts and/or inhibit or prevent the formation of fractures or fissures.

[**0626**] FIG. 17F is a schematic diagram illustrating still another example embodiment of a cut design of a slit **6800**. In some embodiments, the width **6420** and length **6435** of the kerf **6800** may be greater than the width of a laser beam used to cut the kerf **6800**, which can allow the heat impact puddle **6405** to be within the edges of the slit **6800**. In the embodiment illustrated in FIG. 17F, the path **6415** of the laser beam starts with the heat impact puddle **6405** near the bottom right corner of the kerf **6800** but also within the edges of the slit **6800** and travels diagonally to the upper left corner of the kerf **6800** and then along the edges of the kerf **6800**, surrounding the heat impact puddle **6405**, such that the heat impact puddle and the heat affected zone can be removed or substantially removed by the cutting process. In certain such embodiments, the removal of the heat impact puddle **6405** and the heat affected zone can maintain the structural integrity of the struts and/or inhibit or prevent the formation of fractures or fissures.

[**0627**] FIG. 17G is a schematic diagram illustrating still yet another example embodiment of a cut design of a slit **7200**. In some embodiments, the width **6420** and length **6435** of the kerf **7200** may be greater than the width of a laser beam used to cut the kerf **7200**, which can allow the heat impact puddle **6405** to be within the edges of the slit **7200**. In the embodiment illustrated in FIG. 17G, the path **6415** of the laser beam starts with the heat impact puddle **6405** near the bottom left

corner of the kerf 7200 but also within the edges of the slit 7200 and travels in an overlapping spiral pattern within the edges of the kerf 7200 and then along the edges of the kerf 7200, surrounding the heat impact puddle 6405, such that the heat impact puddle and the heat affected zone can be removed or substantially removed by the cutting process. In certain such embodiments, the removal of the heat impact puddle 6405 and the heat affected zone can maintain the structural integrity of the struts and/or inhibit or prevent the formation of fractures or fissures.

[0628] FIG. 17H is a schematic side elevational view of an example embodiment of a bushing 7300. FIG. 17I is a schematic cross-sectional front elevational view of the bushing 7300 of FIG. 17H along the line 17I-17I. The bushing 7300 can be used to assist fixation of a hypotube 7315 to inhibit movement of the hypotube 7315 during a laser cutting process. The hypotube 7315 may be cut to be, for example, the proximal portion 200 of the device 10, 20, 30, or 40. In some embodiments, the bushing 7300 includes a proximal end 7314 through which an uncut hypotube 7315 may be inserted, a middle segment 7310 within which the hypotube 7315 is stabilized, and a distal end 7304 through which the hypotube 7315 emerges to be cut by the laser (e.g., as shown by the slits 7305 in the hypotube 7315 distal to the distal end 7304). As illustrated in FIG. 17I, the bushing 7300 includes a cylindrical hole or aperture 7410 within the middle segment of the bushing 7310 through which the hypotube 7315 traverses. In some embodiments, the aperture 7410 has an inner diameter of at least about 0.001 inches (approx. 0.025 mm) greater than the outer diameter of the hypotube 7315, which can provide stabilization and inhibit friction. The bushing 7300 may comprise metals including, for example, platinum, titanium, nickel, chromium, cobalt, tantalum, tungsten, iron, manganese, molybdenum, alloys thereof including nickel titanium (e.g., nitinol), nickel titanium niobium, chromium cobalt, copper aluminum nickel, iron manganese silicon, silver cadmium, gold cadmium, copper tin, copper zinc, copper zinc silicon, copper zinc aluminum, copper zinc tin, iron platinum, manganese copper, platinum alloys, cobalt nickel aluminum, cobalt nickel gallium, nickel iron gallium, titanium palladium, nickel manganese gallium, stainless steel, shape memory alloys, etc.

[0629] FIG. 17J is a schematic side elevational view of an example embodiment of a collet 7500. FIG. 17K is a schematic cross-sectional front elevational view of the collet 7500 of FIG. 17J along the line 17K-17K. The collet 7500 is a holding device comprising a cylindrical inner surface including kerfs that forms an inner collar 7511 around a hypotube 7315 to be held and the cylindrical hole or aperture 7510 within the inner collar 7511 exerts a clamping force or tension  $F_c$ , measureable in Newtons or pound-feet, on the hypotube 7315 when tightened, for example by an outer collar 7512. In some embodiments, the amount of the clamping force or tension  $F_c$  can be measured in real time using a tension gauge 7513. The collet 7500 may be used to assist with holding a proximal portion 200 of a vascular treatment device, for example the device 10, 20, 30, or 40, and releasing the proximal portion 200 to be advanced forward during a laser cutting process. The amount of clamping force or tension  $F_c$  can be increased or decreased by tightening or releasing the outer collar 7512, either by a manual or automated approach.

[0630] In some embodiments, the collet 7500 includes a proximal end 7514 through which an uncut hypotube 7315 is inserted, a long segment 7515 within which the hypotube is

held with tension  $F_c$ , and stabilized to reduce sag (e.g., between two collets 7300, between a collet 7300 and the bushing 7500, between the bushing 7500 and another bushing 7500), and a distal end 7504 through which the hypotube 7315 passes to be advanced into another collet 7500 or a bushing 7300. The collet 7500 includes a cylindrical hole or aperture 7510 within the inner collar 7511 through which a hypotube 7315 can traverse and be stabilized from motion during a laser cutting process. In some embodiments, the cylindrical hole 7510 has an inner diameter of at least about 0.001 inches (approx. 0.025 mm) greater than the outer diameter of the hypotube 7315. In some embodiments, the collet 7500 may be split into two halves, and each half includes a number of nooks ranging from about 1 nook to about 24 nooks (e.g., between about 1 nook and about 3 nooks, between about 5 nooks and about 7 nooks, between about 9 nooks and about 11 nooks, about 3 nooks). In some embodiments, the nooks may have full thickness 7616, wherein the nook extends fully between the outer surface of the inner collar 7511 to the cylindrical hole or aperture 7510 within the inner collar 7511, or the nooks may have partial thickness 7617, wherein the nook extends partially from outer surface of the inner collar 7511 towards the cylindrical hole or aperture 7510 but does not reach the cylindrical hole or aperture 7510. The nooks 7616 and 7617 within the inner collar 7511 can allow the outer collar 7512 to reduce the diameter of the aperture 7510 within the inner collar 7511 to adequately hold hypotubes 7315 of varying diameters without using different collets 7500. The cylindrical hole or aperture 7510 within the inner collar 7511 can be tightened around the hypotube 7315 to increase or decrease the tension, and the nooks 7616 and 7617 help adjust the tension on the hypotube 7315.

[0631] In some embodiments, the collet 7500 comprises metals such as platinum, titanium, nickel, chromium, cobalt, tantalum, tungsten, iron, manganese, molybdenum, alloys thereof including nickel titanium (e.g., nitinol), nickel titanium niobium, chromium cobalt, copper aluminum nickel, iron manganese silicon, silver cadmium, gold cadmium, copper tin, copper zinc, copper zinc silicon, copper zinc aluminum, copper zinc tin, iron platinum, manganese copper, platinum alloys, cobalt nickel aluminum, cobalt nickel gallium, nickel iron gallium, titanium palladium, nickel manganese gallium, stainless steel, shape memory alloys, etc.

[0632] FIG. 17L is a schematic diagram illustrating an example embodiment of an arrangement of bushings 10160 and collets 10165. The arrangement is configured to hold a hypotube of a proximal portion 200 during a laser cutting process. During the laser cutting process, the hypotube 10210 is advanced forward and held firmly in place substantially without lateral motion when the laser beam is cutting the hypotube 10210, for example in interspersed patterns of rows of kerfs. In some embodiments, the concentrated laser beam is focused onto the hypotube 10210 of the proximal portion 200 via a lens 10145. Any untoward motion of the hypotube 10210 can cause slits or other patterns being cut to have incorrect shapes or to be in incorrect locations. In the example illustrated in FIG. 17L, the hypotube 10210 is held in position by a bushing 10160, which is configured to inhibit motion of the hypotube 10210 prior to the laser beam impact, and two collets 10165, 10167 configured to reduce parabolic sag of the relatively long hypotube 10210 and/or can maintain adequate tension  $F_c$  on the hypotube 10210 as the hypotube 10210 is being advanced towards the laser beam. More or fewer collets 10165, 10167 can be used, for example depend-

ing on the length, stiffness, material, etc. of the hypotube **10210**. The arrangement further includes a hypotube clamp **10185** that is part of a hypotube dispenser **10180**. The hypotube clamp **10185** is configured to hold the hypotube **10210** in position and advance the hypotube **10210** towards the laser beam.

[0633] FIG. 17M is a schematic diagram illustrating an example embodiment of the sage of a hypotube between in an arrangement of bushings and collets **10162**. For example, the bushings and collets **10162** can include three bushings **10165**, **10167**, **10169**, three collets **10165**, **10167**, **10169**, or combinations of bushings and collets. Referring again to in FIGS. 17A and 17L, the handling of a thin-walled relatively long hypotube (e.g., about 7 feet, about 210 cm) can be very different from handling of hypotubes for stents (e.g., about 1 inch, about 2.5 cm). In the example illustrated in FIG. 17M, the hypotube does not lay between the bushings and collets **10162** in a perfectly straight line, but with parabolic sag **10220**. The arrangement of bushings and collets **10162** can reduce the parabolic sag **10220** to reduce cutting errors due to sag.

[0634] The parabolic sag **10220** can be reduce by at least one of the following four procedures: (1) ensure that all of the collets, bushings, and the hypotube clamp are at the exact or substantially the same height **10215** and placing all of the collets, bushings, and the hypotube clamp in or on the same a horizontal plane (e.g., a flat table that may be part of the laser cutting system **10100**); (2) optimizing the distance **10215** between the collets, bushings and hypotube clamp; (3) applying variable tension  $F_t$  at the level of the hypotube clamp **10185**; and/or (4) ensuring that the sag **10220** is no more than between about 2% and about 3% of the height **10215**. If the distance **10215** is too high, then the parabolic sag **20220** increases. If the distance **10215** is too short, the cost of the system **10100** can be excessively high and tends to clutter the workspace area around the laser cutting device. The parabolic sag  $s$  can be calculated using Equation 3:

$$s = wd^2 / 8F_t \tag{Eq. 3}$$

where  $s$  is the sag **10220** of the hypotube,  $w$  is the weight of the hypotube per inch,  $d$  is the distance **10215** between collets, and  $F_t$  is the tension applied to the hypotube by the hypotube clamp **10185**.

[0635] FIG. 17N is a schematic diagram illustrating an example embodiment of a water inlet device **10300**. The water inlet device **10300** can regulate the velocity of the water inflow into a hypotube **7315** through a constrictive water inlet gate **10187**. The flow of water can cool the hypotube **7315** during laser cutting and help remove slag created from the laser cutting process. Fluids other than water may also be used, for example including ethylene glycol (e.g., to increase heat transfer), slurry (e.g., to increase slag removal), etc.

[0636] The water inlet device **10300** includes a series of water inlet tubes or reservoirs **10370** through which the fluid flows before entering the lumen of the proximal portion **200**. In some embodiments, the water inlet device **10300** includes four water inlet tubes **10370**: the highest water inlet tubing **10320** has a fluid velocity  $v_4$  and flows through a height  $h_4$  that is the sum of the distances **10340**, **10335**, **10330**, **10325**; the next highest water inlet tube **10315** has a fluid velocity  $v_3$  and flows through a height  $h_3$  that is the sum of the distances **10335**, **10330**, **10325**; the next highest water inlet tube **10310** has a fluid velocity  $v_2$  and flows through a height  $h_2$  that is the

sum of the distances **10330**, **10325**; the lowest water inlet tube **10305** has a fluid velocity  $v_1$  and flows through a height  $h_1$  that is the distance **10325**.

[0637] At a height  $h_4$  above the ground, the water inlet device **10300** has a pressure  $P_4$  and a fluid velocity  $v_4$ . The fluid entering the hypotube **7315** through the constrictive water inlet gate **10187**, which is at a height  $h_1$  above the ground, has a pressure  $P_1$ , and a fluid velocity  $v_1$ . As the sum of the kinetic energy per unit volume ( $\frac{1}{2}\rho v^2$ ), the potential energy per unit volume ( $\rho gh$ ), and the pressure energy ( $P$ ) remain the same, the density of the fluid  $\rho$  and the acceleration due to gravity  $g$  (980 cm/second<sup>2</sup>) remain constant, the fluid velocity  $v_1$  entering the hypotube **7315** through the constrictive water inlet gate **10187** can be calculated using Equation 4:

$$\frac{1}{2}\rho v_1^2 + \rho gh_1 + P_1 = \frac{1}{2}\rho v_4^2 + \rho gh_4 + P_4$$

or, rearranged,  $v_1 = \sqrt{v_4^2 + 1960(h_4 - h_1) + 2(P_4 - P_1)/\rho}$  (Eq. 4)

[0638] In some embodiments, if the pressures  $P_1$  and  $P_4$  are equal to atmospheric pressure ( $P_1 = P_4 = P_{atm}$ ), the height  $h_1$  of the constrictive water inlet gate **10187** is at ground level ( $h_1 = 0$ ), and the fluid velocity  $v_4$  is initially at rest ( $v_4 = 0$ ), then the fluid velocity  $v_1$  entering the hypotube **7315** through the constrictive water inlet gate **10187** is directly proportional to the height  $h_4$  of the external water inlet regulator device **10300**. By increasing the height  $h_4$  of the external water inlet regulator device **10300**, the fluid velocity  $v_1$  can be increased, and  $v_1$  can be calculated in cm<sup>3</sup>/s using Equation 5:

$$v_1 = \sqrt{1960 \times h_4} \tag{Eq. 5}$$

[0639] At a height  $h_3$  above the ground, the water inlet device **10300** has a pressure  $P_3$  and a fluid velocity  $v_3$ . At a height  $h_2$  above the ground, the water inlet device **10300** has a pressure  $P_2$  and a fluid velocity  $v_2$ . Adaptations of Equations 4 and 5 can be used to calculate the fluid velocity  $v_1$  when the fluid is in the tubes **10315**, **10305**, **10305**.

[0640] The proximal portion **200** may have between 1 longitudinal section (e.g., the same cut pattern) and about 100 longitudinal sections, between 1 longitudinal section and about 50 longitudinal sections, or between about 1 longitudinal section and about 20 longitudinal sections (e.g., about 15 longitudinal sections), for example depending on the intended use. For example, a distal section of the proximal portion **200** may be sturdy and torquable and a distal section of the proximal portion **200** may be soft and flexible, with one or more sections therebetween. One or more longitudinal transitional sections can be between longitudinal sections having a certain pattern, which can inhibit kinking that could result from a direct transition. The transitional sections can be include a linear or nonlinear change to the cut pattern, and, on average, can be the same as the average of the sections proximal and distal thereto.

[0641] The proximal portion **200** comprises, in some embodiments, in longitudinal order from distal to proximal, a first section, a second section, a third section, a fourth section, a fifth section, a sixth section, a seventh section, an eighth section, a ninth section, a tenth section, an eleventh section, a twelfth section, and a thirteenth section. The first section is about 16 inches (approx. 41 cm) long and includes a pitch between slits of about 0.005 inches (approx. 0.13 mm). The third section is about 10 inches (approx. 25 cm) long and includes a pitch between slits of about 0.01 inches (approx. 0.25 mm). The second section is about 2 inches (approx. 5 cm) long and includes a pitch gradually changing from about

0.005 inches (approx. 0.13 mm) to about 0.01 inches (approx. 0.25 mm), with an average pitch of about 0.0075 inches (approx. 0.19 mm). The fifth section is about 10 inches (approx. 25 cm) long and includes a pitch between slits of about 0.02 inches (approx. 0.51 mm). The fourth section is about 2 inches (approx. 5 cm) long and includes a pitch gradually changing from about 0.01 inches (approx. 0.25 mm) to about 0.02 inches (approx. 0.51 mm), with an average pitch of about 0.015 inches (approx. 0.38 mm). The seventh section is about 10 inches (approx. 25 cm) long and includes a pitch between slits of about 0.04 inches (approx. 1 mm). The sixth section is about 2 inches (approx. 5 cm) long and includes a pitch gradually changing from about 0.02 inches (approx. 0.51 mm) to about 0.04 inches (approx. 1 mm), with an average pitch of about 0.03 inches (approx. 0.76 mm). The ninth section is about 10 inches (approx. 25 cm) long and includes a pitch between slits of about 0.08 inches (approx. 2 mm). The eighth section is about 2 inches (approx. 5 cm) long and includes a pitch gradually changing from about 0.04 inches (approx. 1 mm) to about 0.08 inches (approx. 2 mm), with an average pitch of about 0.06 inches (approx. 1.5 mm). The eleventh section is about 10 inches (approx. 25 cm) long and includes a pitch between slits of about 0.16 inches (approx. 4.1 mm). The tenth section is about 2 inches (approx. 5 cm) long and includes a pitch gradually changing from about 0.08 inches (approx. 2 mm) to about 0.16 inches (approx. 4.1 mm), with an average pitch of about 0.12 inches (approx. 3 mm). The thirteenth section is about 6 inches (approx. 15 cm) long and includes no slits. The twelfth section is about 2 inches (approx. 5 cm) long and includes a pitch gradually changing from about 0.16 inches (approx. 4.1 mm) to no slits, with an average pitch of about 0.24 inches (approx. 6.1 mm). The pitches may have a tolerance of  $\pm 0.0005$  inches (approx. 0.013 mm). The lengths of the sections may have a tolerance of  $\pm 0.25$  inches (approx. 6.4 mm). The proximal portion **200** may have a length of about 84 inches (approx. 210 cm). A distal-most section distal to the first section of the proximal portion **200** (e.g., about 2 mm to about 4 mm) may remain uncut for coupling to the distal portion **100** at the joint **300**.

**[0642]** Although the patterns are illustrated in certain figures herein as being generally horizontal or perpendicular to the longitudinal axis of the tubular structure **202**, the slits **204** may be angled, for example between about  $95^\circ$  and about  $115^\circ$  from the longitudinal axis of the tubular structure **202**. In some embodiments, an angle greater than  $90^\circ$  (up to about  $180^\circ$ ) can help to translate torque applied to a proximal segment of the proximal portion **200** during rasping by spreading force across stems and uncut portions of the tubular structure **202**. In some embodiments, an angle greater than  $90^\circ$  can reduce the duration of cutting the slits **204** in the tubular structure **202**.

**[0643]** In some embodiments, the proximal portion **200** is formed by laser cutting a hypotube. For example, at least the proximal end of a hypotube may be clamped for treatment in a laser cutting device that has been programmed with a desired pattern (e.g., interspersed staggered offset patterns as described herein). The distal end may also be clamped in some embodiments. A laser is directed at material to be removed. In some embodiments, the distal end of the proximal portion **200** is not cut to form a bonding zone for coupling the proximal portion **200** to a distal portion **100**. The bonding zone may have a length between about 1 mm and about 4 mm (e.g., about 2 mm). The section of the proximal portion **200** proximal to the proximal end of the cut pattern may be

trimmed (e.g., to provide the proximal portion **200** with a specific length, to fit into packaging, etc.), or may remain uncut, for example to reduce manufacturing steps, since that section of the proximal portion **200** is intended to be outside of a body during a procedure. The proximal end of the proximal portion **200** may be coupled to a handle, coated, etc. for increased manipulability by a user.

**[0644]** Interrupted spiral cut hypotubes may suffer from similar issues as 90 degree alternating slotted hypotubes. Certain strut patterns and interspersed patterns (e.g., the struts in Patterns A and B, which include staggered and offset struts) described herein may be adapted for use by interrupting a spiral cut in a hypotube. In certain such embodiments, the hypotube does not include discrete rows including two kerfs, but include kerfs of varying circumferential widths depending on the desired pattern of struts.

**[0645]** Although certain embodiments described herein are with respect to cutting a tubular structure **202**, a flat sheet may also be cut and then rolled into a tubular member, and optionally heat set to retain the tubular shape. For example, FIGS. **16E** and **16F** can represent either an example of a cut pattern on a sheet or the cut pattern of a flattened tube.

**[0646]** In some embodiments, the proximal portion **200** may comprise something other than or in addition to a tubular member. For example, the proximal portion **200** may comprise a braided structure or a hybrid of a braided structure and a tubular member. Certain such structures may have the same or similar, or different, characteristics (e.g., dimensions, variable flexibility, etc.) as the tubular member described in detail herein and/or the textile structure (e.g., filament material, weave pattern, etc.) **158** described in detail with respect to the distal portion **100** herein.

**[0647]** In embodiments in which the proximal portion **200** is homogenous (e.g., being a single hypotube or braided structure), the proximal portion includes zero attachment points. For example, the proximal portion may comprise a single integral hypotube with a plurality of cut patterns and/or shape setting along a longitudinal length. For another example, the proximal portion may comprise a single integral textile structure with a plurality of weave parameters and/or shape setting along a longitudinal length. Homogenous proximal portions **200** can also include one attachment point or a plurality of attachment points. For example, a plurality of sections of hypotube each having different pattern spacing may be coupled. For another example, a plurality of sections of hypotube each having different shape setting (e.g., with or without a cut pattern) may be coupled. Can have no pitch (straight wires) or pitch (length to complete a circumference). Pitch can be different for each longitudinal section, which can help with heat setting during manufacturing. Pitch can also help with x-ray length measurement. Lengths of longitudinal sections can vary.

**[0648]** FIG. **18A** is a schematic perspective view of a proximal portion **280** of a vascular treatment device comprising a plurality of filaments **282**. The filaments **282** are braided together, for example as described herein with respect to embodiments of distal portions **100**. FIG. **18B** is a front perspective view of the proximal portion **280**. In some embodiments, for example for use in the neurovasculature, the filaments may have a diameter between about 0.35 mm and about 0.65 mm (e.g., between about 0.4 mm and about 0.45 mm), between about 0.1 mm and about 0.34 mm (e.g., between about 0.25 mm and about 0.33 mm), about 0.00125 inches (approx. 0.317 mm). In some embodiments, for



example for use in the peripheral vasculature, the filaments may have a diameter between about 0.5 mm and about 10 mm. Filament materials, shape memory characteristics, braid patterns, oxidation state, etc. may be the same or similar to those described herein with respect to the distal portion 100, or may be adapted for the proximal portion 200. For example, the filaments may cross at a smaller angle (e.g., between about 1° and about 45° (e.g., about 17°)). For other examples, the porosity may be smaller, the density may be larger (e.g., between about 5 PPI and about 50 PPI (e.g., about 32 PPI)), the number of filaments may be more or fewer, the filaments may be thicker or thinner, the radiopacity may be different, the shape memory characteristics may be different, etc.

[0649] FIG. 18C is a perspective view of another example embodiment of a proximal portion 7700 of a vascular treatment device comprising a plurality of filaments 282. The filaments 282 are not braided. For example, the filaments 282 may be spiraled or helically wound in one direction (e.g., allowing torsional rasping in a first direction), in an opposite direction (e.g., allowing torsional rasping in a second direction), not at all (e.g., filaments 282 parallel to the longitudinal axis, as shown in FIG. 18C), and combinations thereof (e.g., coaxial helically wound filaments 282). In some embodiments, the plurality of filaments 282 includes shape memory filaments and radiopaque filaments, combinations thereof, and the like. The embodiment illustrated in FIG. 18C includes 12 filaments 282 that are parallel to the longitudinal axis. Although some examples of the proximal portion 7700 with 12 filaments 282 are provided herein, some embodiments of the proximal portion 200 may include between about 6 filaments and about 120 filaments in accordance with the values provided above and/or proximal portion may include about 6 filaments to about 96 filaments, about 6 filaments to about 72 filaments, about 6 filaments to about 12 filaments, and about 48 filaments.

[0650] FIG. 18D is a schematic side elevational view of an example embodiment of a proximal portion 7800 of a vascular treatment device illustrating an example pattern of radiopaque filaments, for example under x-ray. the proximal portion 7800 may be the proximal portion 200 of the device 10, 20, 30, or 40. The proximal portion 7800 includes, in an expanded state, a plurality of filaments that are spirally or helically wound in one direction. The plurality of filaments includes shape-memory filaments and radiopaque filaments. In some embodiments, the proximal portion 7800 includes, in an expanded state, two radiopaque filaments 7811, 7813 that are interlaced in the form a double sine wave like a “double helix” at least under x-ray. The pattern of radiopacity can allow an operator of a device comprising the proximal portion 7800 to visualize identify the proximal portion 7800 under x-ray. In some embodiments, the double helix includes troughs and peaks, for example at the sides of the proximal portion 7800 that the double helix at least partially creates. In FIG. 18D, distances 7830, 7840, 7850, 7860, 7870 between helical intersection points 7825, 7835, 7845, 7855, 7865, 7875 have substantially uniform dimensions, which can allow the proximal portion 7800 to serve as an angiographic measurement ruler. For example, the distances 7820 can help measure the length of blood clots, the neck of an aneurysm, the length of a stenosis, etc.

[0651] FIG. 18E is a schematic front elevational view of the proximal portion 7800 of FIG. 18D. In FIG. 18E, the material of the filaments is indicated by shading: filaments with no shading include shape-memory material and filaments 7811,

7813 with hatched shading include radiopaque material. The example set up of radiopaque filaments 7811, 7813 illustrated with respect to FIG. 18E can generate a pattern of radiopacity described in FIG. 18D, for example a double sine wave or double helix pattern. The radiopaque filaments 7811, 7813 form two sine waves, which are offset by about 180°, and the sine waves in each pair are offset from the other filaments by about 30°. Although some examples of the proximal portion 7800 including 12 filaments are provided herein, some embodiments of the proximal portion 200 may include between about 6 filaments and about 120 filaments in accordance with the values provided above and/or the proximal portion 200 may include about 6 filaments to about 96 filaments, about 6 filaments to about 72 filaments, about 6 filaments to about 12 filaments, and about 48 filaments, and the number and/or percentage of radiopaque filaments can remain as described above.

[0652] FIG. 18F is a schematic side elevational view of another example embodiment of a proximal portion 7900 of a vascular treatment device illustrating an example pattern of radiopaque filaments, for example under x-ray. The proximal portion 7900 may be the proximal portion 200 of the device 10, 20, 30, or 40. The proximal portion 7900 includes, in an expanded state, a plurality of filaments that are spirally or helically wound in one direction. The plurality of filaments includes shape-memory filaments and radiopaque filaments. In some embodiments, the proximal portion 7900 includes, in an expanded state, two pairs 7910, 7920 of radiopaque filaments 7911, 7913 and 7915, 7917, respectively. The first pair 7910 of radiopaque filaments 7911, 7913 and second pair 7920 of radiopaque filaments 7915, 7917 are interlaced in the form a paired double sine wave like a “dual double helix” at least under x-ray. The pattern of radiopacity can allow an operator of a device comprising the proximal portion 7900 to visualize identify the proximal portion 7900 under x-ray. In some embodiments, the dual double helix includes troughs and peaks, for example at the sides of the proximal portion 7900 that the dual double helix at least partially creates. In FIG. 18F, distances 7930, 7940, 7950, 7960 between intersection points 7935, 7945, 7955, 7965, 7975 have substantially uniform dimensions, which can allow the proximal portion 7900 to serve as an angiographic measurement ruler. For example, the distances 7970 can help measure the length of blood clots, the neck of an aneurysm, the length of a stenosis, etc.

[0653] FIG. 18G is a schematic front elevational view of the proximal portion 7900 of FIG. 18F. In FIG. 18G, the material of the filaments is indicated by shading: filaments with no shading include shape-memory material and filaments 7911, 7913, 7915, 7917 with hatched shading include radiopaque material. The example set up of radiopaque filaments 7911, 7913, 7915, 7917 illustrated in FIG. 18G can generate a pattern of radiopacity described with respect to FIG. 18F, for example a paired double sine wave or dual double helix pattern. The radiopaque filaments 7911, 7913, 7915, 7917 form four sine waves, pairs 7910, 7920 of which are offset by about 180°, and the sine waves in each pair 7910, 7920 are offset from each other by about 30°. Although some examples of the proximal portion 7900 including 12 filaments are provided herein, some embodiments of the proximal portion 200 may include between about 6 filaments and about 120 filaments in accordance with the values provided above and/or the proximal portion 200 may include about 6 filaments to about 96 filaments, about 6 filaments to about 72 filaments,

about 6 filaments to about 12 filaments, and about 48 filaments, and the number and/or percentage of radiopaque filaments can remain as described above.

[0654] FIG. 18H is a schematic side elevational view of still another example embodiment of a proximal portion 8000 of a vascular treatment device illustrating an example pattern of radiopaque filaments, for example under x-ray. The proximal portion 8000 may be the proximal portion 200 of the device 10, 20, 30, or 40. The proximal portion 8000 includes, in an expanded state, a plurality of filaments that are spirally or helically wound in one direction. The plurality of filaments includes shape-memory filaments and radiopaque filaments. In some embodiments, the proximal portion 8000 includes, in an expanded state, two pairs 8010, 8020 of radiopaque filaments 8011, 8012, 8013 and 8015, 8017, 8019, respectively. The first pair 8010 of radiopaque filaments 8011, 8012, 8013 and the second pair 8020 of radiopaque filaments 8015, 8017, 8019 are interlaced in the form a paired triple sine wave like a “reinforced double helix” at least under x-ray. The pattern of radiopacity can allow an operator of a device comprising the proximal portion 8000 to visualize identify the proximal portion 8000 under x-ray. In some embodiments, the reinforced double helix includes troughs and peaks, for example at the sides of the proximal portion 8000 that the reinforced double helix at least partially creates. In FIG. 18H, distances 8030, 8040 between intersection points 8035, 8045, 8055 have substantially uniform dimensions, which can allow the proximal portion 8000 to serve as an angiographic measurement ruler. For example, the distances 8050 can help measure the length of blood clots, the neck of an aneurysm, the length of a stenosis, etc.

[0655] FIG. 18I is a schematic diagram illustrating a front elevational view of the proximal portion 8000 of FIG. 18H. In FIG. 18I, the material of the filaments is indicated by shading: filaments with no shading include shape-memory material and filaments 8011, 8012, 8013, 8015, 8017, 8019 with hatched shading include radiopaque material. The example set up of radiopaque filaments 8011, 8012, 8013, 8015, 8017, 8019 illustrated in FIG. 18I can generate a pattern of radiopacity described in FIG. 18H, for example a paired triple sine wave or reinforced double helix pattern. The radiopaque filaments 8011, 8012, 8013, 8015, 8017, 8019 form pairs 8010, 8020 of three sine waves that are offset by about 180°, and the sine waves in each pair 8010, 8020 are offset from each other by about 30°. Although some examples of the proximal portion 8000 including 12 filaments are provided herein, some embodiments of the proximal portion 200 may include between about 6 filaments and about 120 filaments in accordance with the values provided above and/or the proximal portion 200 may include about 6 filaments to about 96 filaments, about 6 filaments to about 72 filaments, about 6 filaments to about 12 filaments, and about 48 filaments, and the number and/or percentage of radiopaque filaments can remain as described above.

[0656] FIG. 18J is a schematic side elevational view of yet another example embodiment of a proximal portion 8100 of a vascular treatment device illustrating an example pattern of radiopaque filaments, for example under x-ray. The proximal portion 8100 may be the proximal portion 200 of the device 10, 20, 30, or 40. The proximal portion 8100 includes, in an expanded state, a plurality of filaments that are spirally or helically wound in one direction along the central longitudinal axis 8140 at a diameter 8150. The plurality of filaments includes shape-memory filaments and radiopaque filaments.

In some embodiments, the proximal portion 8100 includes, in an expanded state, three radiopaque filaments 8111, 8112, 8113 that are interlaced in the form a three phase sine wave like a “three phase helix” at least under x-ray. The pattern of radiopacity can allow an operator of a device comprising the proximal portion 8100 to visualize and identify the proximal portion 8100 under x-ray. In some embodiments, the three phase helix includes troughs and peaks, for example at the sides of the proximal portion 8100 that the three phase helix at least partially creates.

[0657] In some embodiments, the first radiopaque filament 8111 forms a sine wave having a phase A, the second radiopaque filament 8112 forms a sine wave having a phase B, and the third radiopaque filament 8113 forms a sine wave having a phase C. In some embodiments, the three phase helix includes troughs and peaks, for example at the sides of the distal portion 8100 that the three sine waves at least partially create. Embodiments comprising a three phase sine wave include three pitches: the sine wave formed by the radiopaque filament 8111 has a pitch 8121, the sine wave formed by the radiopaque filament 8112 has a pitch 8122, and the sine wave formed by the radiopaque filament 8113 has a pitch 8123. FIG. 18J shows the pitches 8121, 8122, 8123 as the distances between the lower peaks of the respective sine waves. In the embodiment illustrated in FIG. 18J, the pitches of the sine waves formed by the radiopaque filaments 8111, 8112, 8113 have substantially uniform dimensions (e.g., pitches), although the sine waves may have differing dimensions (e.g., pitches).

[0658] In some embodiments, the distance between each trough or peak of a radiopaque filament 8111, 8112, 8113 with another trough or peak of an adjacent radiopaque filament of the three phase helix is called a phase shift. In FIG. 18J, phase A is offset from phase B by about 7.5° (shown by the distance 8131), phase B is offset from phase C by about 7.5° (shown by the distance 8132), and phase A is offset from phase C by about 15° (shown by the distance 8133). FIG. 18J shows the phase shifts 8131, 8132, 8133 as the distances between the upper peaks of the respective sine waves. The pattern of radiopacity can allow an operator of a device comprising the proximal portion 8100 to visualize and identify the proximal portion 8100 at least under x-ray. In FIG. 18J, the intersection points along the three phase double helix are substantially uniformly spaced by distances 8141 or multiples thereof, which can allow the proximal portion 8100 to serve as an angiographic measurement ruler. For example, the distance 8141 can help an operator to measure the length of blood clots, the neck of an aneurysm, the length of a stenosis, etc.

[0659] FIG. 18K is a schematic front elevational view of the proximal portion 8100 of FIG. 18J. In FIG. 18K, the material of the filaments is indicated by shading: filaments with no shading include shape-memory material and filaments 8111, 8112, 8113 with hatched shading include radiopaque material. The example set up of radiopaque filaments 8111, 8112, 8113 illustrated in FIG. 18K can generate a pattern of radiopacity described in FIG. 18J, for example a three phase helix pattern, or a pattern in which the radiopaque filaments 8111, 8112, 8113 form three sine waves offset by about 120°.

[0660] FIG. 18L is a schematic side elevational view of still yet another example embodiment of a proximal portion 8200 of a vascular treatment device illustrating an example pattern of radiopaque filaments, for example under x-ray. The proximal portion 8200 may be the proximal portion 200 of the

device **10**, **20**, **30**, or **40**. The proximal portion **8200** includes a textile structure including shape-memory filaments and radiopaque filaments. The proximal portion **8200** includes, in an expanded state, radiopaque filaments **8211**, **8212**, **8213** that are interlaced in the form a paired three phase helix at least under x-ray. The filament **8211** is reinforced with a second radiopaque filament and the proximal portion **8200** may include additional radiopaque filaments that are non-reinforced. The pattern of radiopacity can allow an operator of a device comprising the proximal portion **8200** to visualize identify the proximal portion **8200** at least under x-ray. In some embodiments, the paired three phase helix includes troughs and peaks, for example at the sides of the proximal portion **8200** that the paired three phase helix at least partially create. A paired three phase helix includes a pitch for each reinforced filament (e.g., a pitch **8221** for the sine wave created by the filaments **8211**) and a pitch for each non-reinforced filament (e.g., a pitch **8222** for the sine wave created by the filament **8212**, a pitch **8223** for the sine wave created by the filament **8213**). In FIG. **18L**, the intersection points along the paired triple helix are substantially uniformly spaced, which can allow the proximal portion **8200** to serve as an angiographic measurement ruler. For example, the distances between intersections can help an operator to measure the length of blood clots, the neck of an aneurysm, the length of a stenosis, etc.

[0661] FIG. **18M** is a schematic front elevational view of the proximal portion **8200** of FIG. **18L**. In FIG. **18M**, the material of the filaments is indicated by shading: filaments with no shading include shape-memory material and filaments **8211**, **8212**, **8213** with hatched shading include radiopaque material. The example set up of radiopaque filaments **8211**, **8212**, **8213** illustrated in FIG. **18M**, will generate a pattern of radiopacity described in FIG. **18L**, for example a reinforced three phase helix, or a pattern in which the radiopaque filaments offset by about  $120^\circ$ , and the radiopaque filaments **8211** within the reinforced sine wave are offset by about  $30^\circ$ .

[0662] FIG. **18N** is a schematic side elevational view of another example embodiment of a proximal portion **8400** of a vascular treatment device comprising a plurality of filaments **156** braided together with uniform braid angle and pore size. In some embodiments, the braid angle, the PPI, and the pore size may be uniform or variable across the length of the proximal portion **8400**.

[0663] In some embodiments in which the proximal portion **200** comprises a plurality of filaments, radiopaque markers as described above with respect to a distal end of the distal portion **100** (e.g., dip-coated polymer with radiopaque particles) may be used instead of or in addition to a radiopaque marker band **25**.

[0664] As discussed above, a knitted structure (e.g., comprising transverse wires) may be more rigid than a woven structure and more suitable for a proximal portion **200**. In certain such embodiments, a woven or knitted proximal portion **200** and a woven distal portion **100** may comprise at least some of the same filaments, with at least one parameter (e.g., existence of transverse filaments, weave pattern, etc.) changing between the proximal portion **200** and the distal portion **100** and/or along the length of the proximal portion **200** (e.g., to longitudinally vary flexibility).

[0665] In some embodiments, the proximal portion **200** comprises a hybrid of a braided structure and a patterned hypotube. In certain such embodiments, the number of

attachment points between different sections of the proximal portion is at least 1. In some embodiments, the length of a hypotube section of the proximal portion **200** is between about 0.1 cm and about 60 cm (e.g., between about 30 cm and about 60 cm) and the length of a braided section of the proximal portion **200** is between about 20 cm and about 209.9 cm (e.g., between about 150 cm and about 180 cm). In embodiments in which length of the hypotube section is between about 1 mm and about 10 mm, the hypotube section can act as a bridge between the distal portion **100** and the proximal portion **200**. In certain such embodiments, the hypotube may be uncut, for example because the short length may provide adequate flexibility at that section.

[0666] In some embodiments, the proximal portion **200** comprises a cut tube as described herein, and the distal portion **100** comprises a device such as a vascular treatment device homogeneously or integrally cut (e.g., from the same tube or sheet) or cut separately and then attached to the proximal portion **200**.

[0667] FIG. **19A** is a schematic diagram illustrating an example embodiment of variation of slits along the length of an example embodiment of a proximal portion **260**. The schematic nature of FIG. **19A** is apparent, for example, by the illustration of the slits as being incomplete (showing only one slit half) and having stems that are substantially aligned. The proximal portion **260** includes a first longitudinal section **262** including slits **263**, a second longitudinal section **264** including slits **265**, a third longitudinal section **266** including slits **267**, and a fourth longitudinal section **268** including slits **269**. In the first longitudinal section **262**, the slits **263** are spaced apart by a distance  $d_1$ . In the second longitudinal section **264**, the slits **265** are spaced apart by a distance  $d_2$ . In the third longitudinal section **266**, the slits **267** are spaced apart by a distance  $d_3$ . In the fourth longitudinal section **268**, the slits **269** are spaced apart by a distance  $d_4$ . The distance  $d_4$  is greater than the distance  $d_3$ , which is greater than the distance  $d_2$ , which is greater than the distance  $d_1$ . The variation in the distances  $d_1$ ,  $d_2$ ,  $d_3$ ,  $d_4$  can affect the flexibility of the proximal portion **260**, in which a shorter distance provides more flexibility and a longer distance provides less flexibility. The first longitudinal section **262** is more flexible than the second longitudinal section **264**, which is more flexible than the third longitudinal section **266**, which is more flexible than the fourth longitudinal section **268**. Although some examples of the proximal portion **200** with 4 longitudinal sections are provided herein, some embodiments of the proximal portion **200** may include between about 1 longitudinal section and about 15 longitudinal sections, in accordance with the values provided above and/or proximal portion may include about 2 longitudinal sections to about 4 longitudinal sections, about 6 longitudinal sections to about 8 longitudinal sections, about 10 longitudinal sections to about 12 longitudinal sections, and about 13 longitudinal sections.

[0668] Referring again to FIGS. **2A**, **2B**, **3A**, **3B**, **4A**, **4B**, and **5D-5G**, in some embodiments, a radiopaque marker band **25** is welded (e.g., butt welded, laser welded), bonded, and/or soldered to the distal end of the proximal portion **200**. The marker band **25** can help distinguish the distal end of the proximal portion **200** and the proximal end of the distal portion **100** and/or to identify the joint **300**. In some embodiments, a ring (e.g., comprising platinum and/or other radiopaque material) is welded (e.g., laser-welded) to the distal end of the proximal portion **200** using a plurality of rivets. For

example, the ring may be welded using two rivets circumferentially spaced about 180° apart.

[0669] FIG. 19B is a schematic diagram illustrating an example embodiment of variation of slits and radiopaque markers along the length of an example embodiment of a proximal portion 8500 of a vascular treatment device. The proximal portion 8500 may be the proximal portion 200 of the device 10, 20, 30, or 40. In some embodiments, a radiopaque marker band is welded (e.g., butt welded, laser welded), bonded, and/or soldered to the proximal portion 200 at regular intervals, which may help to measure clot length (e.g., because the length of the distal portion 100 is known). In some embodiments, as illustrated in FIG. 19B, radiopaque material is attached (e.g., laser welded) like “rivets” into the slits 8535 of the proximal portion 8500 at regular intervals and interspersed with slits 8545 that are not filled with radiopaque material or rivets, which may help to measure clot length (e.g., because the length of the distal portion 100 is known) or to measure the degree or length of a stenosis in a vessel, or to measure the diameter of a vessel or to measure the dimensions of an aneurysm arising from a vessel for example, measuring the neck of the aneurysm for intra-operative decision making on device selection. Referring again to FIG. 19A, the distance between slits  $d_4$  in the fourth longitudinal section 8540 of the proximal portion 8500 is greater than the distance  $d_3$  in the third longitudinal section 8530 of the proximal portion 8500, which is greater than the distance  $d_2$  in the second longitudinal section 8520 of the proximal portion 8500, which is greater than the distance  $d_1$  in the first longitudinal section 8510 of the proximal portion 8500. Whether the regularly-spaced radiopaque material is a band or attached material, the radiopaque markers may be separated by distances of about 0.1 mm to about 50 mm, including, but not limited to, about 0.5 mm to about 1 mm, about 1 mm to about 2 mm, about 2 mm to about 3 mm, about 3 mm to about 4 mm, about 4 mm to about 5 mm, about 5 mm to about 8 mm, about 8 mm to about 10 mm, about 10 mm to about 12 mm, about 12 mm to about 15 mm, about 15 mm to about 25 mm, about 25 mm to about 35 mm, and about 35 mm to about 50 mm, including overlapping ranges thereof. In some embodiments, indicia (e.g., numbers, radiopaque material of different dimensions, etc.) may be used to provide further information about all or some of the markers. Although some examples of the proximal portion 8500 with 4 longitudinal sections are provided herein, some embodiments of the proximal portion 200 may include between about 1 longitudinal section and about 15 longitudinal sections, in accordance with the values provided above and/or proximal portion 200 may include about 2 longitudinal sections to about 4 longitudinal sections, about 6 longitudinal sections to about 8 longitudinal sections, about 10 longitudinal sections to about 12 longitudinal sections, and about 13 longitudinal sections.

[0670] In some embodiments, the tubular structure 202 is cold worked or has not been subjected to heat treatment. In some embodiments, the tubular structure 202 is straight annealed or undergoes heat treatment in a straight orientation, for example before or after patterning. Heat treating certain materials can impart shape memory such that the proximal portion 200 has a certain shape (e.g., straight, including curved sections, etc.) absent outside forces.

[0671] In some embodiments, the proximal portion 200 includes at least some super-elastic material that can, for example, return to a certain shape after bending due to stress-

induced Martensite (SIM) without any particular change in temperature. Super-elastic materials can unbend (or, if the shape is curved, return to that curve) substantially instantaneously when forces causing the bend are removed (e.g., by advancement to different vasculature). In some embodiments, unbending of the proximal portion 200 is at least partially because the proximal portion 200 includes at least some shape memory material that can, for example, return to a certain shape after bending due to heat-activated austenitic transformation (e.g., upon a particular change in temperature such as greater than room temperature (about 25° C.), about body temperature (approx. 37° C.), etc.). Shape-memory materials can unbend slowly upon contact with warm fluid (e.g., blood at body temperature, warm saline).

[0672] In some embodiments, the shape memory effect can be one-way (e.g., a stress-induced change in shape returns to a baseline shape upon heating, while there is no further change upon cooling). The material remembers one shape with the one-way shape memory effect, the shape at high temperature. In some embodiments, the shape memory effect can be two-way (e.g., a stress-induced change in shape returns close to baseline shape upon heating, while a second shape can be achieved upon cooling). The material remembers two shapes with the two-way shape memory effect, a first shape at high temperature and a second shape at low temperature.

[0673] FIG. 19C is a schematic diagram illustrating still another example embodiment of a proximal portion 8600 of a vascular treatment device. the proximal portion 8600 may be the proximal portion 200 of the device 10, 20, 30, or 40. In some embodiments, different longitudinal sections of the proximal portion 8600 can include different materials and/or shape setting with different austenitic temperatures. For example, a distal section coupled to the proximal portion 8600 may be shape set to a straight configuration such that the distal section returns to a straight shape when not acted upon by vascular forces. For another example, each of the longitudinal sections 8610, 8620, 8630, 8640 can have a different shape set. In some embodiments, the distal-most sections 8610, 8620 of the proximal portion 8600 may be significantly martensitic, which can allow distal flexibility, and sections 8630, 8640 proximal thereto can be significantly austenitic namely, which can provide sturdiness and/or torquability. In some embodiments, at least about 25%, at least about 50%, or at least about 75% of the length of the proximal portion 8600 is martensitic. Although some examples of the proximal portion 8600 including 4 longitudinal sections are provided herein, some embodiments of the proximal portion 200 may include between about 1 longitudinal section and about 15 longitudinal sections, in accordance with the values provided above and/or proximal portion may include about 2 longitudinal sections to about 4 longitudinal sections, about 6 longitudinal sections to about 8 longitudinal sections, about 10 longitudinal sections to about 12 longitudinal sections, and about 13 longitudinal sections.

[0674] FIG. 19D is a schematic cut away side view of another example embodiment of heat treatment device 5401. In some embodiments, the heat treatment device 5401 may be similar to the heat treatment device 5400 described with respect to FIG. 10M. For example, the heat treatment device 5401 comprises a fluidized sand bath including a detachable flange 5405 as described herein. The device 5485 to be heat treated may comprise, for example, a proximal portion 200 of device 10, 20, 30 or 40. The heat treatment device 5401

comprises portion a reel-to-reel device or spiral dispenser **5490**, **5495** configured to deploy the device **5485** into the fluidized sand bath **5401** to selectively heat treat each longitudinal section of the device **5485**, for example in contrast to the devices **5435** in the basket **5470**. Proximal portions **200** may also be heat treated in a basket **5470** and distal portions **100** may also be heat treated by being fed through the reel-to-reel device **5490**, **5495**.

[0675] FIG. 19E is a schematic partial cut away side view of a portion of the heat treatment device **5401** of FIG. 19D. In some embodiments, the material of the proximal portion **5485** (e.g., hypotube, textile structure, wire) is loaded into the reel-to-reel device **5490** and the free end of the proximal portion **5485** is passed through the hollow conduit **5475**, exposes a longitudinal section loop inside the fluidized sand bath **5401**, passes through the hollow conduit **5477**, and is loaded into the reel-to-reel device **5495**. In some embodiments, the reel-to-reel device **5490**, **5495** can be rotated using a manual or automated approach such that the direction of motion of the reel-to-reel device **5490** is in the direction **5492** and the direction of motion of the reel-to-reel device **5495** is in the direction **5496**. The reel-to-reel device **5490** includes a rotating handle or gear **5493** for rotating the reel-to-reel device **5490** in the direction **5492** either using a manual or automated approach. The reel-to-reel device **5495** includes a rotating handle or gear **5498** for rotating the reel-to-reel device **5495** in the direction **5498** either using a manual or automated approach.

[0676] In some embodiments, the detachable flange **5405** includes detachable air-sealant rivets **5480** on the outer surface of the flange **5405**, on the inner surface of the flange **5405**, or on the outside surface and the inside surface of the flange **5405**. The reversible attachment points of the air-sealant rivets **5480** to the hollow conduits **5475**, **5477** may include a luer lock mechanism, a ball and socket mechanism, a wire and hook mechanism, a c-shaped clasp and hook mechanism, combinations thereof, and the like. The detachable flange **5405** and the air-sealant rivets **5480** can mete longitudinal sections the device **5485** for heat treatment in the fluidized sand bath **5401** and can permit the safe removal of the device **5485** from the fluidized sand bath **5401**, for example for placement in a cooling bath after heat treatment.

[0677] In some embodiments, the reel-to-reel device **5490**, **5495** allows different longitudinal sections of the device **5485** to be shape set with different austenitic temperatures. For example, in some embodiments, the distal-most sections of a proximal portion **200** may be significantly martensitic, which can allow distal flexibility, and sections proximal thereto can be significantly austenitic, which can provide sturdiness and/or torquability. For another example, some sections of a proximal portion can be shape set to take a certain shape upon cooling (e.g., a straight shape in a water bath below room temperature).

[0678] FIG. 19F is a schematic diagram illustrating still yet another example embodiment of a proximal portion **8700** of a vascular treatment device, for example the proximal portion **200** of the device **10**, **20**, **30**, or **40**. The proximal portion **8700** comprises a wire **8715** and a hypotube **8705** that are fixably coupled at a joint **8710**, for example as described with respect to the joints **300** herein. In some embodiments, the joint **8710** may be formed using processes such as laser welding the distal end of the microwire **8715** to the proximal end of the hypotube **8705**, coupling the distal end of the microwire **8715** to the proximal end of the hypotube **8705** using a plurality of

rivets, butt welding the distal end of the microwire **8715** to the proximal end of the hypotube **8705**, centerless grinding of the distal end of the microwire **8715** such that the microwire **8715** can be inlaid into the inner lumen of the proximal end of the hypotube **8705** and then welded, etc. In some embodiments, the hypotube **8705** includes the distal end of the proximal portion **200** and the wire **8715** includes the proximal end of the proximal portion **200**. In some embodiments, the length of the proximal portion **8700** may range from about 80 cm to about 210 cm, including the length of the hypotube **8705** ranging from about 0.1 cm to about 60 cm (e.g., about 30 cm, about 60 cm) and the length of the wire ranging from about 20 cm to about 209.9 cm (e.g., about 150 cm, about 180 cm). In some embodiments, the hypotube **8705** and the wire **8715** have an outer diameter between about 0.35 mm and about 0.65 mm (e.g., between about 0.4 mm and about 0.45 mm), between about 0.1 mm and about 0.5 mm (e.g., between about 0.25 mm and about 0.33 mm (e.g., about 0.0125 inches (approx. 0.318 mm))). In some embodiments, for example for use with peripheral vasculature, the hypotube **8705** and the wire **8715** have an outer diameter between about 0.5 mm and about 10 mm. Substantially the entire length, portions, or none of the hypotube **8705** may be laser cut, for example with the interspersed kerf patterns described herein. A braided tubular structure may be substituted for some or all of the hypotube **8705**.

[0679] In some embodiments, the hypotube **8705** and/or the wire **8715** may comprise shape memory material that is shape set differently (e.g., different austenitic temperature, different shape, etc.) over different longitudinal sections. In some embodiments, the hypotube **8705** and/or the wire may be uniformly super-elastic. In some embodiments, the hypotube **8705** and/or the wire may comprise non-shape memory material. In some embodiments, the hypotube **8705** and the wire **8715** may comprise the same material or different materials. Suitable materials for the hypotube **8705** and the wire **8715** may include, for example, platinum, titanium, nickel, chromium, cobalt, tantalum, tungsten, iron, manganese, molybdenum, and alloys thereof including nickel titanium (e.g., nitinol), nickel titanium niobium, chromium cobalt, copper aluminum nickel, iron manganese silicon, silver cadmium, gold cadmium, copper tin, copper zinc, copper zinc silicon, copper zinc aluminum, copper zinc tin, iron platinum, manganese copper, platinum alloys, cobalt nickel aluminum, cobalt nickel gallium, nickel iron gallium, titanium palladium, nickel manganese gallium, stainless steel, shape memory alloys, etc. Suitable materials for the hypotube **8705** and the wire **8715** may also include, for example, polymers such as polylactic acid (PLA), polyglycolic acid (PGA), polylactic co-glycolic acid (PLGA), polycaprolactone (PCL), polyorthoesters, polyanhydrides, and copolymers thereof. Suitable materials may also include alloys (e.g., nitinol, chromium cobalt, platinum tungsten, etc.) and combinations of materials (e.g., filaments with a radiopaque core or cladding in combination with a cladding or core, respectively, of a different material, a plurality of filaments including different materials, etc.).

[0680] The proximal portion **200** can be coupled to a distal portion **200** at a joint **300**, as described in further detail herein.

[0681] The distal portion **100** and the proximal portion **200** may be coupled at a joint **300**. In some embodiments, the joint includes bonding material such as solder or epoxy. Solder may be easier to control during manufacturing processes than epoxy, for example because its flow properties are very tem-

perature dependent. Use of solder rather than epoxy can allow a device comprising the joint **300** to be sterilized using gamma radiation, which could damage polymers such as epoxy and which is generally less expensive than chemical sterilization techniques such as ethylene oxide sterilization.

**[0682]** The proximal end of the distal portion **100** may be coupled within the distal end of the proximal portion **200** (e.g., filaments coupled to the inside of a hypotube) using inlay bonding. In some embodiments, inlay bonding does not increase the diameter or thickness beyond the diameter or thickness of the distal portion **100** or the proximal portion **200**. In some embodiments, inlay bonding does not reduce the flexibility below the flexibility of the distal portion **100** or the distal section of the proximal portion **200**. The proximal end of the distal portion **100** may be coupled outside the distal end of the proximal portion **200** (e.g., filaments coupled to the outside of a hypotube) using overlay bonding. A combination of inlay bonding and overlay bonding is also possible (e.g., some filaments coupled to the inside of a hypotube and some filaments coupled to the outside of the hypotube, or at least some filaments coupled to both the inside and outside of a hypotube). Inlay bonding may inhibit coupling material such as solder or epoxy from flaking off. In some embodiments comprising overlay bonding, a heat-shrink tube (e.g., comprising a heat shrink polymer such as PTFE or PVC) may reduce the risk of material flaking and may make the outer surface more uniform (e.g., compared to round filaments on a round hypotube), but could increase the outer diameter of the device and/or reduce the availability of gamma radiation sterilization.

**[0683]** FIG. **20A** is a schematic diagram illustrating an example embodiment of a joint **3000** between a proximal portion **200** and a distal portion **100**. The distal portion **100** includes a plurality of woven filaments and a proximal bulb **110** and the proximal portion **200** includes a tubular structure **202**, a plurality of slits **204**, and a radiopaque marker band **25**, although other distal portions **100** and/or proximal portions **200** (e.g., as described herein) are also possible. FIG. **20B** is a schematic cross-section of the joint of FIG. **20A** along the line **20B-20B**. FIG. **20A** illustrates an example embodiment of an inlay bond including solder **302** at the joint **3000** between the distal portion **100** and the proximal portion **200**. FIGS. **20D-20F** schematically illustrate a method of coupling a braided tube to a hypotube.

**[0684]** In some embodiments using inlay bonding, a distal end (e.g., a flared distal end) of the proximal portion **200** may be mechanically crimped around the inlaid proximal end of the distal portion **100**.

**[0685]** In some embodiments, the solder comprises a silver-based lead-free solder including about 96.5% tin and about 2.5% silver. The solder may comprise a eutectic solder having a solidus temperature  $T_S$  that is substantially the same as the liquidus temperature  $T_L$  at which the solder completely melts into a liquid ( $T_S=T_L$ ), for example about 221° C. (approx. 430° F.) (e.g., Indalloy #121, available from Indium Corporation of Clinton, N.Y.). The eutectic silver-based lead-free solder is slowly melted at a rate of between about 1° C. and about 2° C. per second (e.g., for a duration of about 50 seconds) from about 171° C. up to the liquidus temperature  $T_L$ . Once the liquidus temperature  $T_L$  has been reached, the rate of melting increases to between about 2.5° C. and about 3° C. per second (e.g., for a duration of about 20 seconds) from about 221° C. up to the peak melting temperature  $T_m$ , for example between about 246° C. and about 271° C. The dura-

tion of melting of the silver-based lead-free solder from the liquidus temperature  $T_L$  to the peak melting temperature  $T_m$  may be less than about 45 seconds. The liquid solder may be injected using a precision injector syringe, for example as described with respect to FIGS. **20A-20F**. The molten solder is then rapidly cooled at a rate of less than about 4° C. per second (e.g., about 2° C. per second for a duration of about 50 seconds) from the peak melting temperature  $T_m$  to the cooling temperature  $T_c$ , which may be about 171° C., resulting in a strong solder joint because of formation of a fine grain structure. A strong solder joint may be useful for procedures that can place strain on the solder joint, for example torsional rasping. Further cooling below the cooling temperature  $T_c$  may be performed at an extremely rapid rate of greater than about 4° C. per second (e.g., about 5° C. per second for a duration of about 35 seconds). The rapid cooling may be performed using a water bath (e.g., at a temperature between about 20° C. and about 25° C.) for a duration of between about 30 seconds and about 120 seconds. The water bath may remove flux that was used in the soldering process. The tensile strength of a joint achievable with using silver-based lead-free solder is relatively high at about 5800 psi. If the eutectic silver-based lead-free solder is rapidly melted at a rate of greater than about 2° C. per second (e.g., for a duration of less than 25 seconds) from about 171° C. up to the liquidus temperature  $T_L$ , then the solder joint strength may be compromised, for example due to formation of solder balls or beads. In some embodiments, if the soldering is attempted at a temperature below or above the peak melting temperature  $T_m$  and/or if the duration of the melting of the silver-based lead-free solder from the liquidus temperature  $T_L$  to the peak melting temperature  $T_m$  is greater than about 45 seconds, then the solder joint strength may be compromised, for example due to formation of intermetallics.

**[0686]** In some embodiments, if the eutectic silver-based lead-free solder is extremely rapidly cooled at a rate of greater than about 4° C. per second (e.g., about 5° C. per second for a duration of about 20 seconds) from the peak melting temperature  $T_m$  to the cooling temperature  $T_c$ , then the solder joint strength may be compromised, for example forming a joint having a tensile strength of less than about 2700 psi, for example due to formation of a coarse grain structure. Mechanical detachment can achieve shear strengths greater than 2700 psi, and may be useful in vascular treatment devices in which the distal portion **100** is desirably detachable from the proximal portion **200** at the region of joint **300**, for example in flow diverters or flow disruptors as described herein.

**[0687]** In some embodiments, the solder comprises a gold-based lead-free solder including about 80% gold and about 20% tin. The solder may comprise a eutectic solder having a solidus temperature  $T_S$  that is substantially the same as the liquidus temperature  $T_L$  at which the solder completely melts into a liquid ( $T_S=T_L$ ), for example about 280° C. (approx. 535° F.) (e.g., Indalloy #182, available from Indium Corporation of Clinton, N.Y.). The eutectic gold-based lead-free solder is slowly melted at a rate of between about 1° C. and about 2° C. per second (e.g., for a duration of about 50 seconds) from about 230° C. up to the liquidus temperature  $T_L$ . Once the liquidus temperature  $T_L$  has been reached, the rate of melting increases to between about 2.5° C. and about 3° C. per second (e.g., for a duration of about 20 seconds) from about 280° C. up to the peak melting temperature  $T_m$ , for example between about 305° C. and about 330° C. The dura-

tion of melting of the gold-based lead-free solder from the liquidus temperature  $T_L$  to the peak melting temperature  $T_m$  may be less than about 45 seconds. The liquid solder may be injected using a precision injector syringe, for example as described with respect to FIGS. 20A-20F. The molten solder is then rapidly cooled at a rate of less than about 4° C. per second (e.g., about 2° C. per second for a duration of about 50 seconds) from the peak melting temperature  $T_m$  to the cooling temperature  $T_c$ , which may be about 230° C., resulting in a strong solder joint because of formation of a fine grain structure. A strong solder joint may be useful for procedures that can place strain on the solder joint, for example torsional rasping. Further cooling below the cooling temperature  $T_c$  may be performed at a extremely rapid rate of greater than about 4° C. per second (e.g., about 5° C. per second for a duration of about 35 seconds). The rapid cooling may be performed using a water bath (e.g., at a temperature between about 20° C. and about 25° C.) for a duration of between about 30 seconds and about 120 seconds. The water bath may remove flux that was used in the soldering process. The tensile strength of a joint achievable with using silver-based lead-free solder is relatively extremely high at about 40,000 psi. If the eutectic gold-based lead-free solder is rapidly melted at a rate of greater than about 2° C. per second (e.g., for a duration of less than 25 seconds) from about 230° C. up to the liquidus temperature  $T_L$ , then the solder joint strength may be compromised, for example due to formation of solder balls or beads. In some embodiments, if the soldering is attempted at a temperature below or above the peak melting temperature  $T_m$  and/or if the duration of the melting of the gold-based lead-free solder from the liquidus temperature  $T_L$  to the peak melting temperature  $T_m$  is greater than about 45 seconds, then the solder joint strength may be compromised, for example due to formation of intermetallics.

**[0688]** In some embodiments, prior to coupling, the proximal end of the distal portion **100** and/or the distal end of the proximal portion **200** are treated to at least partially or completely remove oxide. For example, the distal end of the proximal portion **200** may be substantially burr-free and/or substantially oxide-free, and the proximal end of the distal portion **100** is etched (e.g., dipped in acid) to be substantially oxide-free.

**[0689]** In some embodiments, prior to soldering an alloy of nickel and titanium (e.g., nitinol) to nitinol or to a different material (e.g., stainless steel), flux (e.g., Indalloy Flux #3 or Indalloy Flux #2, both available from Indium Corporation of Clinton, N.Y.) can be used to reduce nickel and titanium surface oxides. Flux #3 has an activation temperature of between about 96° C. and about 343° C. and contains chlorides. Flux #2 has an activation temperature of between about 100° C. and about 371° C. and does not contain zinc or heavy metal chlorides. The appropriate flux can be applied using a brush, a swab, a spray, combinations thereof, and the like. After the soldering process, the flux residual can be removed by cooling and washing the solder joint in a water bath as described herein, by adding citric acid to the water bath, by a water sonication process, by mechanical scrubbing, combinations thereof, and the like.

**[0690]** In some embodiments in which the surface oxides of nickel and titanium cannot be adequately removed from the distal portion **100** using flux, soldering at the joint **300** can still be performed between the distal portion **100** and a proximal portion **200** comprising a different material (e.g., stainless steel) by soldering the radiopaque filaments within the

distal portion **100** (e.g., comprising platinum tungsten, etc.) to the proximal portion **200** (e.g., comprising stainless steel). Increasing the number of radiopaque filaments in the distal portion **100** (e.g., to between about 25% and about 50% of the total number of filaments) can result in a strong solder joint, whereas decreasing the number of radiopaque filaments in the distal portion (e.g., to between about 5% and about 25% of the total number filaments) can result in a weak solder joint that may be useful in devices wherein the distal portion **100** of a vascular treatment device is desirably detachable from the proximal portion **200** at the region of joint **300**, for example in flow diverters or flow disruptors as described herein.

**[0691]** In some embodiments in which filaments of the distal portion **100** and/or the proximal portion **200** comprises nickel (e.g., including nitinol strands), nickel oxide may be formed when the strands are heat treated in gas including oxygen such as ambient air. Nickel oxide can inhibit soldering of the distal portion **100** to the proximal portion **200**, for example when the distal portion **100** and the proximal portion **200** comprise dissimilar materials. For example after soldering, a process for joining a distal portion **100** including oxidized nitinol filaments to a proximal portion **200** comprising a different material may include post-processing, polishing, and/or sandblasting, which could weaken the filaments. Non-oxidized filaments (e.g., by performing the heat treatment in an inert atmosphere such as argon or nitrogen) can generally be joined to dissimilar materials without such post-processing, polishing, and/or sandblasting. Filaments including other oxides (e.g., titanium oxide) may also be joined to dissimilar materials without such post-processing, polishing, and/or sandblasting.

**[0692]** Referring again to FIGS. 20A and 20D-20F, the proximal end of the distal portion **100** is inserted into the distal end of the proximal portion **200**. In some embodiments, solder **302** and optionally flux are delivered from a delivery device **8810** (e.g., comprising a J-shaped tube **8815** that can be inserted through the distal-most slit **204** of the proximal portion **200**) in the gap between the filaments of the distal portion **100** and the tubular structure **202** of the proximal portion **200** in a first position (e.g., as illustrated by the solder **8820** in FIG. 20E and the solder **302b** in FIG. 20B), then the delivery device is rotated about 90°, then solder **302** and optionally flux are delivered in a second position (e.g., as illustrated by the solder **302c** in FIG. 20B), then the delivery device is rotated about 90°, then solder **302** and optionally flux are delivered in a third position (e.g., as illustrated by the solder **8820** in FIG. 20F and the solder **302d** in FIG. 20B), then the delivery device is rotated about 90°, then solder **302** and flux are delivered in a fourth position (e.g., as illustrated by the solder **302a** in FIG. 20B), and then the delivery device **8810** is removed and the solder **302** allowed to cool. In some embodiments, solder **302** and optionally flux are delivered from a delivery device **8810** (e.g., comprising a J-shaped tube **8815** that can be inserted through the distal-most slit **204** of the proximal portion **200**, for example to serve as a precision injector syringe) in the gap between the filaments of the distal portion **100** and the tubular structure **202** of the proximal portion **200** in a first position (e.g., as illustrated by the solder **8820** in FIG. 20E and the solder **302b** in FIG. 20B), then the delivery device is rotated about 180°, then solder **302** and optionally flux are delivered in a second position (e.g., as illustrated by the solder **8820** in FIG. 20F and the solder **302d** in FIG. 20B), then the delivery device is rotated about 90°, then solder **302** and optionally flux are delivered in a third

position (e.g., as illustrated by the solder **302a** in FIG. 20B), then the delivery device is rotated about 180°, then solder **302** and flux are delivered in a fourth position (e.g., as illustrated by the solder **302c** in FIG. 20B), and then the delivery device **8810** is removed and the solder **302** allowed to cool. FIG. 20B shows solder **302a**, **302b**, **302c**, **302d** between the distal portion **100** and the proximal portion **200** and spaced about 90° apart, which may be formed for example by the methods described herein. The device may be tilted during soldering to inhibit the solder **302** from occluding the distal-most slit **204**, which could reduce flexibility in an area where flexibility is generally desired.

[0693] Other solder amounts and positions are also possible. For example, the solder can be fully arcuate or in more or fewer positions (e.g., three positions about 120° apart, five positions about 72° apart, etc.), but embodiments such as illustrated in FIG. 20B may reduce manufacturing complexity (e.g., because about ¼ circumference or about 90° spacing can be an intuitive measurement). Substantially equal spacing can inhibit the formation of uneven strengths and stresses, which could, for example, break the joint **300** during use. Increasing the number of positions can reduce defects due to spacing error (e.g., the more positions, the less effect of any one inaccurate position), but increase the manufacturing complexity (e.g., using smaller angles, less solder per delivery, more precise spacing, etc.). The amount and placement of solder may affect strength (e.g., more solder generally increases strength, which may be beneficial to uses such as torsional rasping) and/or flexibility (e.g., more solder generally reduces flexibility, which may be disadvantageous for maneuverability). Embodiments including localized bonding agent **302** (e.g., as illustrated in FIGS. 20A and 20B) have been found to have good flexibility without compromising strength.

[0694] FIG. 20C is a schematic cross-section illustrating and example embodiment of filament **156** area in comparison to tubular structure **202** area. The filaments **156** of the distal portion **100** each have an area  $\pi d_f^2/4$ , where  $d_f$  is the diameter of the filament **156**. The inside of the proximal portion **200** has an area  $\pi d_i^2/4$ , where  $d_i$  is the inner diameter of the tubular structure **202**. The area of the inside of the tubular structure **202** not occupied by a filament **156** is approximately  $\pi(d_i^2 - nd_f^2)/4$ , where  $n$  is the number of filaments **156**. For example, if the distal portion **100** comprises 48 filaments **156** each having a diameter of 0.001 inches (approx. 0.025 mm) and the proximal portion **200** comprises a tubular structure **202** having an inner diameter of 0.01 inches (approx. 0.25 mm), the area not occupied by a filament **156** is  $\pi(0.25^2 - 48 \times 0.025^2)/4 = 0.026 \text{ mm}^2$ . The ratio of the area occupied by filaments **156** to the inner area of the tubular structure **202** is  $nd_f^2/d_i^2$ . For example, if the distal portion **100** comprises 48 filaments **156** each having a diameter of 0.001 inches (approx. 0.025 mm) and the proximal portion **200** comprises a tubular structure **202** having an inner diameter of 0.01 inches (approx. 0.25 mm), the ratio is  $48 \times 0.025^2 / 0.25^2 = 0.48$  or 48%.

[0695] Using the length of the joint **3000** and the area available for filaments **156**, a volume of bonding agent (e.g., the solder **302**) may be determined. If bonding agent is only to be between the outside of the filaments **156** and the inside of the tubular structure **202**, even less area is available, with the area of the proximal neck of the distal portion **100** subtracted. In some embodiments, between about 45% and about 60% (e.g., between about 51% and about 55%) of the cross-sectional area between the distal portion **100** and the proximal

portion **200** is bonding agent. If the filaments **156** have different shapes and/or dimensions, the formulae can be appropriately adjusted.

[0696] FIG. 21A is a schematic diagram illustrating another example embodiment of a joint **3100** between a proximal portion **200** and a distal portion **100**. The distal portion **100** includes a plurality of woven filaments **156** and a proximal bulb **110** and the proximal portion **200** includes a tubular structure **202** and a plurality of slits **204**, although other distal portions **100** and/or proximal portions **200** (e.g., as described herein) are also possible. FIG. 21B is a schematic cross-section of the joint **3100** of FIG. 21A along the line 21B-21B. FIG. 21A illustrates an example embodiment of an inlay bond including epoxy **304** at the joint **3100** between the distal portion **100** and the proximal portion **200**.

[0697] The proximal end of the distal portion **100** is inserted into the distal end of the proximal portion **200**. In some embodiments, epoxy is delivered from a delivery device (e.g., a J-shaped tube inserted through the distal-most slit **204** of the proximal portion **200**) in the gap between the filaments of the distal portion **100** and the tubular structure **202** of the proximal portion **200** in a first position, then the delivery device is rotated about 180°, then epoxy **304** is delivered in a second position, and then the delivery device is removed and the epoxy **304** allowed to dry. FIG. 21B shows epoxy **304a**, **304b** between the distal portion **100** and the proximal portion **200** and spaced about 180° apart and epoxy **304c** between the filaments, as epoxy tends to flow. FIG. 21A also shows the epoxy **304** having flowed down around the proximal end of the distal portion **100**. Excess epoxy **304** may optionally be removed using a bore or the like. FIG. 21C is a photograph illustrating the inlay bonding approach of FIG. 21A.

[0698] FIG. 22A is a schematic diagram illustrating yet another example embodiment of a joint **3200** between a proximal portion **200** and a distal portion **100**. The distal portion **100** includes a plurality of woven filaments and a proximal bulb **110** and the proximal portion **200** includes a tubular structure **202**, a plurality of slits **204**, and a radiopaque marker band **25**, although other distal portions **100** and/or proximal portions **200** (e.g., as described herein) are also possible. FIG. 22B is a schematic cross-section of the joint **3200** of FIG. 22A along the line 22B-22B. FIG. 22A illustrates an example embodiment of an inlay bond including bonding material (e.g., solder (and optionally flux) or epoxy) **306** at the joint **3200** between the distal portion **100** and the proximal portion **200**.

[0699] The filaments **156** at the proximal end of the distal portion **100** are inserted onto a sleeve or tube or pinch cylinder **308**. The sleeve **308** may comprise metal (e.g., a portion of a hypotube (e.g., comprising stainless steel), platinum, titanium, nickel, chromium, cobalt, tantalum, tungsten, iron, manganese, molybdenum, alloys thereof (e.g., nitinol, chromium cobalt, stainless steel, etc.), and combinations thereof (e.g., cladding, banding, etc.)), polymer (e.g., a heat shrink tube), combinations thereof, and the like. In some embodiments, the sleeve **308** has a length between about 1 mm and about 5 mm. In some embodiments, the sleeve **308** has a wall thickness or a difference between outer diameter and inner diameter between about 0.001 inches (approx. 0.025 mm) and about 0.002 inches (approx. 0.51 mm). In some embodiments, a metal sleeve **308** does not inhibit the use of gamma radiation sterilization. The filaments **156** may be pressure fit into the sleeve **308** or loosely inserted into the sleeve **308**. In some embodiments, the sleeve **308** is clamped after insertion



of the filaments 156. In some of the embodiments, at least some of the filaments 156 may be welded (e.g., laser welded, laser butt welded, laser rivet welded, etc.) to the sleeve 308.

[0700] The proximal end of the distal portion 100, including the sleeve 308, is inserted into the distal end of the proximal portion 200. In some embodiments, bonding material 306 is delivered from a delivery device (e.g., a J-shaped tube inserted through the distal-most slit 204 of the proximal portion 200) in the gap between the sleeve 308 and the tubular structure 202 of the proximal portion 200 while rotating the delivery device, and then the delivery device is removed and the bonding material 306 is allowed to set. FIG. 22B shows bonding material 306 between the sleeve 308 and the tubular structure 202. The bonding material 306 is shown as being arcuate, but can be in generally discrete spots, for example as discussed above. The embodiment illustrated in FIGS. 22A and 22B has been found to have a strong bond, but somewhat limited flexibility.

[0701] Referring again to FIG. 22A, in some embodiments, the bonding material 306 is between the sleeve 308 and the tubular structure 202, and being between the filaments 156 and the sleeve 308 and/or between the filaments 156 and the tubular structure 202. Bonding material 306 at the distal end of the sleeve 308 can help secure the filaments 156 to the sleeve 308 and/or to each other.

[0702] In some embodiments in which the bonding material 306 comprises epoxy, some bonding material may be below the sleeve 308, as epoxy tends to flow. FIG. 22A also shows an example of some bonding material 306 having flowed down around the proximal end of the distal portion 100. Excess bonding material 306 may optionally be removed using a bore or the like. In some embodiments in which the bonding material 306 comprises solder, the device may be tilted during soldering to inhibit the solder 306 from occluding the distal-most slit 204, which could reduce flexibility in an area where flexibility is generally desired.

[0703] FIG. 23A is a schematic diagram illustrating still another example embodiment of a joint 3300 between a proximal portion 200 and a distal portion 100. The distal portion 100 includes a plurality of woven filaments 156 and a proximal bulb 110 and the proximal portion 200 includes a tubular structure 202, a plurality of slits 204, and a radiopaque marker band 25, although other distal portions 100 and/or proximal portions 200 (e.g., as described herein) are also possible. FIG. 23B is a schematic cross-section of the joint 3300 of FIG. 23A along the line 23B-23B. FIG. 23C is a schematic cross-section of the joint 3300 of FIG. 23A along the line 23C-23C. FIG. 23A illustrates an example embodiment of an inlay bond including bonding material (e.g., solder (and optionally flux) or epoxy) 310 at the joint 3300 between the distal portion 100 and the proximal portion 200.

[0704] The filaments 156 at the proximal end of the distal portion 100 are inserted onto a ring or pinch ring 312. The ring 312 may comprise metal (e.g., a portion of a hypotube (e.g., comprising stainless steel)), polymer (e.g., a heat shrink tube), combinations thereof, and the like. In some embodiments, a metal ring 312 does not inhibit the use of gamma radiation sterilization. The filaments 156 may be pressure fit into the ring 312 or loosely inserted into the ring 312. In some embodiments, the ring 312 is clamped after insertion of the filaments 156. In some of the embodiments, at least some of the filaments 156 may be welded (e.g., laser welded, laser butt welded, laser rivet welded, etc.) to the ring 312. The filaments

156 are radially outwardly frayed proximal to the proximal end of the ring 312, which can help to secure the filaments 156 in the ring 312.

[0705] The proximal end of the distal portion 100, including the ring 312 and the frayed proximal ends of the filaments 156, is inserted into the distal end of the proximal portion 200. In some embodiments, bonding material 310 is delivered from a delivery device (e.g., a J-shaped tube inserted through the distal-most slit 204 of the proximal portion 200) in the gap between the ring 312 and the tubular structure 202 of the proximal portion 200 while rotating the delivery device, and then the delivery device is removed and the bonding material 310 is allowed to set. FIG. 23B shows bonding material 310 between the ring 312 and the tubular structure 202. The bonding material 310 is shown as being arcuate, but can be in generally discrete spots, for example as discussed above. The embodiment illustrated in FIGS. 23A-23C has been found to be more flexible than the embodiment illustrated in FIGS. 22A and 22B, and the bond is nearly as strong, for example because the bond in the cross-sections illustrated in FIGS. 22B and 23B are substantially similar or identical.

[0706] Referring again to FIG. 23A, in some embodiments, the bonding material 310 is between the ring 312 and the tubular structure 202, and being between the filaments 156 and the ring 312 and/or between the filaments 156 and the tubular structure 202. Bonding material 310 at the proximal end and/or the distal end of the ring 312 can help secure the filaments 156 to the ring 312 and/or to each other.

[0707] In some embodiments in which the bonding material 310 comprises epoxy, some bonding material may be below the ring 312, as epoxy tends to flow. FIGS. 23A and 23C also shows an example of some bonding material 310 having flowed down around the proximal end of the distal portion 100. In FIG. 23C, the frayed ends of the filaments 156 are dispersed in the bonding material 310. Excess bonding material 310 may optionally be removed using a bore or the like. In some embodiments in which the bonding material 310 comprises solder, the device may be tilted during soldering to inhibit the solder 310 from occluding the distal-most slit 204, which could reduce flexibility in an area where flexibility is generally desired.

[0708] FIG. 24A is a schematic diagram illustrating another example embodiment of a joint 3400 between a proximal portion 200 and a distal portion 100. The distal portion 100 includes a plurality of woven filaments and a proximal bulb 110 and the proximal portion 200 includes a tubular structure 202 and a plurality of slits 204, although other distal portions 100 and/or proximal portions 200 (e.g., as described herein) are also possible. FIG. 24A illustrates an example embodiment of an overlay bond including bonding material 320 at the joint 3400 between the distal portion 100 and the proximal portion 200. The distal end of the proximal portion 200 is inserted into the proximal end of the distal portion 100. In some embodiments, the proximal neck of the distal portion 100 is wide enough to accept the distal end of the proximal portion 200, for example being tubular with a large enough diameter, including an outward proximal flare, etc. Adjusting the diameter of necks of the distal portion 100 can include, for example, using hypotube during a shape-setting process as described above. The distal end of the proximal portion 200 to which the distal portion 100 is bonded may be devoid of slots 204.

[0709] FIG. 24B is a schematic diagram illustrating yet another example embodiment of a joint 3500 between a

proximal portion **200** and a distal portion **100**. The distal portion **100** includes a plurality of woven filaments and the proximal portion **200** includes a tubular structure **202** and a plurality of slits **204**, although other distal portions **100** and/or proximal portions **200** (e.g., as described herein) are also possible. FIG. **24B** illustrates another example embodiment of an overlay bond including bonding material **320** at the joint **3400** between the distal portion **100** and the proximal portion **200**. The distal end of the proximal portion **200** is inserted into the proximal end of the distal portion **100**. In some embodiments, the proximal neck of the distal portion **100** is wide enough to accept the distal end of the proximal portion **200**, for example being tubular with a large enough diameter, including an outward proximal flare, etc. Adjusting the diameter of necks of the distal portion **100** can include, for example, using hypotube during a shape-setting process as described above. The distal end of the proximal portion **200** to which the distal portion **100** is bonded may be devoid of slots **204**.

[0710] In some embodiments, for example the embodiment illustrated in FIG. **24A** and/or the embodiment illustrated in FIG. **24B**, bonding material (e.g., solder and optionally flux, and/or epoxy) **320** is delivered from a delivery device in the gap between the filaments of the distal portion **100** and the tubular structure **202** of the proximal portion **200**. The bonding material **320** can be fully arcuate, in one position, or in a plurality of positions. Overlay bonding can be at least partially through the filaments of the distal portion **100**, so the control over the bonding material **320** may be greater than inlay bonding approaches. The amount and placement of bonding material **320** may affect strength (e.g., more bonding material **320** generally increases strength, which may be beneficial to uses such as torsional rasping) and/or flexibility (e.g., more bonding material **320** generally reduces flexibility, which may be disadvantageous for maneuverability).

[0711] FIG. **24C** is a schematic diagram showing the joints **3400**, **3500** of FIGS. **24A** and **24B**. The length of the joint **3400** is **322**, the length of the joint **3500** is **324**, and the difference between the length of the joint **3400** and the joint **3500** is **326**. The length of a joint **300** may be at least partially based on the bonding material used. For example, solder may be stronger than epoxy such that less solder, and less length, is used. In some embodiments, the joint **3400** comprises solder and the joint **3500** comprises epoxy, and FIG. **24C** provides a schematic comparison of the longer length used based on the weaker bond of epoxy. In some embodiments, the length of a joint **300** comprising solder is about 25% to about 50% less than the length of a joint **300** comprising epoxy (e.g., the length **322** is about 25% to about 50% less than the length **324** and/or the length **326** is about 25% to about 50% of the length **324**). A shorter length of the joint **300** may increase flexibility, for example by reducing the areas of the device without flexibility-imparting slots **204** and/or flexible filaments.

[0712] FIG. **24D** is a schematic diagram illustrating yet another example embodiment of a joint **3600** between a proximal portion **200** and a distal portion **100**. The distal portion **100** includes a plurality of woven filaments and the proximal portion **200** includes a tubular structure **202** and a plurality of slits **204**, although other distal portions **100** and/or proximal portions **200** (e.g., as described herein) are also possible. FIG. **24D** illustrates yet another example embodiment of an overlay bond including bonding material **320** at the joint **3600** between the distal portion **100** and the proximal

portion **200**. The distal end of the proximal portion **200** is inserted into the proximal end of the distal portion **100**. In some embodiments, the proximal neck of the distal portion **100** is wide enough to accept the distal end of the proximal portion **200**, for example being tubular with a large enough diameter, including an outward proximal flare, etc. Adjusting the diameter of necks of the distal portion **100** can include, for example, using hypotube during a shape-setting process as described above. The distal end of the proximal portion **200** to which the distal portion **100** is bonded may be devoid of slots **204**.

[0713] In some embodiments, for example the embodiment illustrated in FIG. **24D**, bonding material (e.g., solder and optionally flux, and/or epoxy) **320** is delivered from a delivery device in the gap between the filaments of the distal portion **100** and the tubular structure **202** of the proximal portion **200**. The bonding material **320** can be fully arcuate, in one position, or in a plurality of positions. Overlay bonding can be at least partially through the filaments of the distal portion **100**, so the control over the bonding material **320** may be greater than inlay bonding approaches. The amount and placement of bonding material **320** may affect strength (e.g., more bonding material **320** generally increases strength, which may be beneficial to uses such as torsional rasping) and/or flexibility (e.g., more bonding material **320** generally reduces flexibility, which may be disadvantageous for maneuverability).

[0714] The joint **3600** further comprises a sleeve **330**. The sleeve **330** may comprise metal (e.g., a portion of a hypotube (e.g., comprising stainless steel)), polymer (e.g., a heat shrink tube (e.g., comprising PET, fluoropolymer (e.g., PTFE, Viton, polyvinylidene fluoride (PVDF), fluorinated ethylene propylene (FEP), etc.), silicone rubber, polyolefin (e.g., Iridium™, available from Cobalt Polymers of Cloverdale, Calif.), PVC, Pebax® (e.g., Palladium, available from Cobalt Polymers of Cloverdale, Calif.)), combinations thereof, and the like. In some embodiments, the sleeve **330** has a length between about 1 mm and about 5 mm. In some embodiments, the sleeve **330** has a wall thickness or difference between inner diameter and outer diameter between about 0.00025 inches (approx. 0.006 mm) and about 0.00125 inches (approx. 0.03 mm) (e.g., about 0.0005 inches (approx. 0.013 mm), about 0.001 inches (approx. 0.025 mm)). In some embodiments, a metal sleeve **330** does not inhibit the use of gamma radiation sterilization. In some embodiments, the sleeve **330** is clamped after being placed around the proximal end of the distal portion **100**. The sleeve **330** may inhibit bonding material **320** from flaking off and/or may make the outer diameter of the joint **3600** more uniform, but may increase the diameter of the device. In some embodiments, the sleeve **330** may be used without the bonding material **320**.

[0715] FIG. **25A-1** is a schematic diagram illustrating an example embodiment of a mechanical detachment system **10550**. FIG. **25A-2** is a schematic diagram illustrating an example embodiment of the components of the mechanical detachment system **10550** of FIG. **25A-1**. The mechanical detachment system **10550** can be used, for example, to releasably couple a distal portion **100** (e.g., comprising a woven textile structure **158**, which may include woven bulbs **110**) to a proximal portion **200** (e.g., comprising a tubular member **202**, which may include slits **204** and a radiopaque marker band **25**). The detachment system **10550** comprises a wire **11730** comprising a plurality of ridges **11732**, **11734**, **11736**, **11738**, which may be in a horizontal or angled pattern, in an

staggered interspersed pattern, combinations thereof, and the like (e.g., like the threads of a screw or the threads of a luer lock). The ridges **11732**, **11734**, **11736**, **11738** may be laser cut (e.g., by removing material proximal and distal thereto). In some embodiments, the proximal end of the distal portion **100** comprising a woven textile structure having various braiding patterns, for example including one-over-one-under-one, one-over-one-under-two, one-over-two-under-two, two-over-one-under-one, two-over-one-under-two, three-over-one-under-one, three-over-one-under-two, three-over-one-under-three, three-over-two-under-one, three-over-two-under-two, three-over-three-under-one, three-over-three-under-two, three-over-three-under-three, two-over-two-under-one, two-over-two-under-two, etc. In the embodiment illustrated in FIG. 25A-2, the distal portion **100** has a one-over-one-under-one braiding pattern and variable pore sizes. The pores between the filaments **11705**, **11710** create a groove **11702** into which the ridge **11732** can be mechanically forced, the pores between the filament **11710** and the upper filament **11715** create a groove **11704** into which the ridge **11734** can be mechanically forced, the pores between the lower filament **11715** and the filament **11720** create a groove **11706** into which the ridge **11736** can be mechanically forced, and the pores under the filament **11720** create a groove **11708** into which the ridge **11738** can be mechanically forced. During desired attachment, an operator rotates the wire **11730** (e.g., counterclockwise). As the wire **11730** unravels (e.g., unscrews from a luer lock), the ridges **11732**, **11734**, **11736**, **11738** disengage or untangle from the grooves **11702**, **11704**, **11706**, **11708**, which can allow the distal portion **100** to exit the proximal portion **200**.

[0716] In some embodiments, suitable materials for the wire **11730** may include, for example, platinum, titanium, nickel, chromium, cobalt, tantalum, tungsten, iron, manganese, molybdenum, and alloys thereof including nickel titanium (e.g., nitinol), nickel titanium niobium, chromium cobalt, copper aluminum nickel, iron manganese silicon, silver cadmium, gold cadmium, copper tin, copper zinc, copper zinc silicon, copper zinc aluminum, copper zinc tin, iron platinum, manganese copper, platinum alloys, cobalt nickel aluminum, cobalt nickel gallium, nickel iron gallium, titanium palladium, nickel manganese gallium, stainless steel, shape memory alloys, etc. Suitable materials may also include polymers such as polylactic acid (PLA), polyglycolic acid (PGA), poly lactic co-glycolic acid (PLGA), polycaprolactone (PCL), polyorthoesters, polyanhydrides, and copolymers thereof. Suitable materials may also include alloys (e.g., nitinol, chromium cobalt, platinum tungsten, etc.) and combinations of materials (e.g., filaments with a radiopaque core or cladding in combination with a cladding or core, respectively, of a different material, a plurality of filaments including different materials, etc.).

[0717] FIG. 25B is a schematic diagram of a partial cross-sectional view of an example embodiment of a mechanical detachment system **10600**. The mechanical detachment system **10600** can be used, for example, to releasably couple a distal portion **100** (e.g., comprising a woven textile structure **158**) to a proximal portion **200** (e.g., comprising a tubular member **202**). The detachment system **10600** comprises a shape-memory wire **10555** formed into one or more shapes **10605** and optionally a coil **10610**. The shape **10605** may include one or more of sphere, oblong, egg, oval, ellipse, spiral, twisted, figure-8, helical, triangle, rectangle, parallelogram, rhombus, square, diamond, pentagon, hexagon, hepta-

gon, octagon, nonagon, decagon, quatrefoil, trapezoid, trapezium, other polygons, curvilinear or bulged versions of these and other shapes, combinations thereof, and the like. The wire **10555** is held by an operator or mechanically anchored to a structure proximal to the distal portion **100**. When the detachment system **10700** is at a first temperature (e.g., about 25° C.), the shape **10605** engages or entangles intersections of the filaments of the distal portion **100** such that the proximal end of the distal portion is substantially stationarily positioned in the distal end of the proximal portion **200**. When the detachment system **10600** is at a second temperature (e.g., about 37° C.), the shape **10605** begins to straighten due to the shape memory properties of the wire **10555**, which has been heat treated to assume a non-shape (e.g., substantially linear) shape upon reaching  $A_f$ . As the shape **10605** transforms, the wire **10555** disengages or untangles from the intersections of the filaments of the distal portion **100**, which can allow the distal portion **100** to exit the proximal portion **200**. When the detachment system **10600** is at a first temperature (e.g., about 25° C.), the optional coil **10610** is in a coiled state (e.g., as shown in FIG. 25B). When the detachment system **10600** is at a second temperature (e.g., about 37° C.), the coil **10610** begins to straighten due to the shape memory properties of the wire **10555**, which has been heat treated to assume a non-coiled (e.g., substantially linear) shape upon reaching  $A_f$ . As the coil **10610** straightens, the wire **10555** moves in the direction **10650**, which can, for example, indicate to a user that the one-way shape memory properties are taking effect.

[0718] In some embodiments, the detachment system **10600** comprises a shape-memory wire **10555** formed into one or more shapes **10605** and optionally a coil **10610**. The wire **10555** is held by an operator or mechanically anchored to a structure proximal to the distal portion **100**. When the detachment system **10600** is at a first temperature (e.g., about 25° C.), the shape **10605** engages or entangles intersections of the filaments of the distal portion **100** such that the proximal end of the distal portion is stationarily positioned in the distal end of the proximal portion **200**. When the detachment system **10600** is at a second temperature achieved upon contact with blood at body temperature (e.g., about 37° C.), the distal portion **100** further expands to an expanded configuration and the shape **10605** further expands and engages or entangles intersections of the filaments of the distal portion **100** such that the proximal end of the distal portion is substantially stationarily positioned in the distal end of the proximal portion **200**. When the detachment system **10600** is at a third temperature achieved by hand injecting cold saline through the microcatheter or guide catheter (e.g., at about 18° C.), the shape **10605** begins to straighten due to the two-way shape memory properties of the wire **10555**, which has been heat treated to assume a non-shape (e.g., substantially linear) shape upon reaching  $A_f$  (e.g., between about 10° C. and about 18° C.). As the shape **10605** unravels, the wire **10555** disengages or untangles from the intersections of the filaments of the distal portion **100**, which can allow the distal portion **100** to exit the proximal portion **200**. When the detachment system **10600** is at a first temperature (e.g., about 25° C.), the optional coil **10610** is in a coiled state (e.g., as shown in FIG. 25C). When the detachment system **10600** is at a second temperature (e.g., about 37° C.), the optional coil **10610** is in an expanded coiled state (e.g., as shown in FIG. 25C). When the detachment system **10600** is at a third temperature (e.g., about 18° C.), the coil **10610** begins to straighten due to the shape memory properties of the wire **10555**, which has been

heat treated to assume a non-coiled (e.g., substantially linear) shape upon reaching  $A_f$  (e.g., between about 10° C. and about 18° C.). As the coil **10610** straightens, the wire **10555** moves in the direction **10650**, which can, for example, indicate to a user that the two-way shape memory properties are taking effect.

[0719] FIG. 25C is a schematic diagram of a partial cross-sectional view of another example embodiment of a mechanical detachment system **10700**. The mechanical detachment system **10700** can be used, for example, to releasably couple a distal portion **100** (e.g., comprising a woven textile structure **158**) to a proximal portion **200** (e.g., comprising a tubular member **202**). The detachment system **10700** comprises a shape-memory wire **10557** formed into one or more balls **10615** and optionally a coil **10610**. The wire **10557** is held by an operator or mechanically anchored to a structure proximal to the distal portion **100**. When the detachment system **10700** is at a first temperature (e.g., about 25° C.), the ball **10615** engages or entangles intersections of the filaments of the distal portion **100** such that the proximal end of the distal portion is substantially stationarily positioned in the distal end of the proximal portion **200**. When the detachment system **10700** is at a second temperature (e.g., about 37° C.), the ball **10615** begins to straighten due to the shape memory properties of the wire **10557**, which has been heat treated to assume a non-ball (e.g., substantially linear) shape upon reaching  $A_f$ . As the ball **10615** unravels, the wire **10557** disengages or untangles from the intersections of the filaments of the distal portion **100**, which can allow the distal portion **100** to exit the proximal portion **200**. When the detachment system **10700** is at a first temperature (e.g., about 25° C.), the optional coil **10610** is in a coiled state (e.g., as shown in FIG. 25C). When the detachment system **10700** is at a second temperature (e.g., about 37° C.), the coil **10610** begins to straighten due to the shape memory properties of the wire **10557**, which has been heat treated to assume a non-coiled (e.g., substantially linear) shape upon reaching  $A_f$ . As the coil **10610** straightens, the wire **10557** moves in the direction **10650**, which can, for example, indicate to a user that the one-way shape memory properties are taking effect.

[0720] In some embodiments, the detachment system **10700** comprises a shape-memory wire **10557** formed into one or more shapes **10605** and optionally a coil **10610**. The wire **10557** is held by an operator or mechanically anchored to a structure proximal to the distal portion **100**. When the detachment system **10700** is at a first temperature (e.g., about 25° C.), the ball **10615** engages or entangles intersections of the filaments of the distal portion **100** such that the proximal end of the distal portion is stationarily positioned in the distal end of the proximal portion **200**. When the detachment system **10700** is at a second temperature achieved upon contact with blood at body temperature (e.g., about 37° C.), the distal portion **100** further expands to an expanded configuration and the ball **10615** further expands and engages or entangles intersections of the filaments of the distal portion **100** such that the proximal end of the distal portion is substantially stationarily positioned in the distal end of the proximal portion **200**. When the detachment system **10700** is at a third temperature achieved by hand injecting cold saline through the microcatheter or guide catheter (e.g., at about 18° C.), the ball **10615** begins to straighten due to the two-way shape memory properties of the wire **10557**, which has been heat treated to assume a non-shape (e.g., substantially linear) shape upon reaching  $A_f$  (e.g., between about 10° C. and about

18° C.). As the ball **10615** unravels, the wire **10557** disengages or untangles from the intersections of the filaments of the distal portion **100**, which can allow the distal portion **100** to exit the proximal portion **200**. When the detachment system **10700** is at a first temperature (e.g., about 25° C.), the optional coil **10610** is in a coiled state (e.g., as shown in FIG. 25C). When the detachment system **10700** is at a second temperature (e.g., about 37° C.), the optional coil **10610** is in an expanded coiled state (e.g., as shown in FIG. 25C). When the detachment system **10700** is at a third temperature (e.g., about 18° C.), the coil **10610** begins to straighten due to the shape memory properties of the wire **10557**, which has been heat treated to assume a non-coiled (e.g., substantially linear) shape upon reaching  $A_f$  (e.g., between about 10° C. and about 18° C.). As the coil **10610** straightens, the wire **10557** moves in the direction **10650**, which can, for example, indicate to a user that the two-way shape memory properties are taking effect.

[0721] FIG. 25D is a schematic diagram of a partial cross-sectional view of yet another example embodiment of a mechanical detachment system **10800**. The mechanical detachment system **10800** can be used, for example, to releasably couple a distal portion **100** (e.g., comprising a woven textile structure **158**) to a proximal portion **200** (e.g., comprising a tubular member **202**). The detachment system **10800** comprises parts of the distal portion **100** and the proximal portion **200**. The distal end of the proximal portion **200** comprises slits **10815**, **10818**, recesses, radially outward dimples, combinations thereof, and the like. Parts **10805**, **10810** of the proximal end of the distal portion **100** are mechanically forced into the slits **10815**, **10818** of the proximal portion **200**. As described above, the distal portion **100** may include shape-memory filaments configured to assume a shape upon reaching a certain temperature. When the detachment system **10800** is at a first temperature (e.g., about 25° C.), the parts **10805**, **10810** of the distal portion **100** remain in the slits **10815**, **10818** of the proximal portion **200**. When the detachment system **10800** is at a second temperature (e.g., about 37° C.), the sections of the distal portion **100** comprising the parts **10805**, **10810** begin to straighten due to the one-way shape memory properties of the distal portion **100**, which has been heat treated to assume a non-mechanically forced (e.g., substantially cylindrical) shape upon reaching  $A_f$ . As the section of the distal portion **100** straightens, the parts **10805**, **10810** move out of the slits **10815**, **10818**, which can allow the distal portion **100** to exit the proximal portion **200**. Although some examples of the distal portion **100** are provided herein, some embodiments of the ends of the distal portion **100** may be mechanically forced into slits from inside-out or outside-in based on whether the embodiment refers to the distal portion **100** of device **10**, **20**, **30** or **40**.

[0722] In some embodiments, the detachment system **10800** comprises parts of the distal portion **100** and the proximal portion **200** of a device **10**, **20**, **30** or **40** as described herein. The distal end of the proximal portion **200** comprises slits **10815**, **10818**, and may include recesses, radially outward dimples, combinations thereof, and the like. Parts **10805**, **10810** of the proximal end of the distal portion **100** are mechanically forced into the slits **10815**, **10818** of the proximal portion **200**. As described above, the distal portion **100** may include shape-memory filaments configured to assume a shape upon reaching a certain temperature. When the detachment system **10800** is at a first temperature (e.g., about 25° C.), the parts **10805**, **10810** of the distal portion **100** remain in

the slits **10815**, **10818** of the proximal portion **200**. When the detachment system **10800** is at a second temperature achieved on contact with blood at body temperature (e.g., about 37° C.), the parts **10805**, **10810** of the distal portion **100** further expand into the slits **10815**, **10818** of the proximal portion **200**. When the detachment system **10800** is at a third temperature achieved by hand injecting cold saline through a microcatheter or guide catheter (e.g., at about 18° C.), the sections of the distal portion **100** comprising the parts **10805**, **10810** begin to straighten due to the two-way shape memory properties of the distal portion **100**, which has been heat treated to assume a non-mechanically forced (e.g., substantially cylindrical) shape upon reaching  $A_c$  (e.g., between about 10° C. and about 18° C.). As the section of the distal portion **100** straightens, the parts **10805**, **10810** move out of the slits **10815**, **10818**, which can allow the distal portion **100** to exit the proximal portion **200**.

[0723] Although some examples of the distal portion **100** are provided herein, some embodiments of the ends of the distal portion **100** may be mechanically forced into slits from inside-out or outside-in based on whether the embodiment refers to the distal portion **100** of device **10**, **20**, **30** or **40**. Although some examples of the proximal portion **200** are provided herein, some embodiments of the ends of the proximal portion **200** of device **10**, **20**, **30** or **40** may include slits or recesses in horizontal or angled laser cut patterns, staggered interspersed patterns, laser cut patterns of different shapes including one of sphere, oblong, egg, oval, ellipse, spiral, twisted, figure-8, helical, triangle, rectangle, parallelogram, rhombus, square, diamond, pentagon, hexagon, heptagon, octagon, nonagon, decagon, quatrefoil, trapezoid, trapezium, other polygons, curvilinear or bulged versions of these and other shapes, combinations thereof, and the like.

[0724] FIG. 25E is a schematic diagram of a partial cross-sectional view of an example embodiment of a mechanical detachment system **10900**. The mechanical detachment system **10900** can be used, for example, to releasably couple a distal portion **100** (e.g., comprising a woven textile structure **158**) to a proximal portion **200** (e.g., comprising a tubular member **202**). The detachment system **10900** comprises a shape-memory wire **10550** formed into a substantially linear shape or formed into one or more shapes **10625** and optionally a coil **10610**. The shapes **10625** may include one of linear, sphere, oblong, egg, oval, ellipse, spiral, twisted, figure of 8 shape, helical, triangle, rectangle, parallelogram, rhombus, square, diamond, pentagon, hexagon, heptagon, octagon, nonagon, decagon, quatrefoil, trapezoid, trapezium, other polygons, curvilinear or bulged versions of these and other shapes, combinations thereof, and the like. The proximal end of the distal portion **100** is anchored to the wire **10550** by solder (for example, a eutectic silver-based lead-free solder). In some embodiments, if the eutectic silver-based lead-free solder is rapidly cooled at a rate of greater than about 4° C. per second (e.g., about 5° C. per second for a duration of about 20 seconds) from the peak melting temperature  $T_m$ , which is between about 246° C. and about 271° C., to the cooling temperature  $T_c$ , which is about 171° C., the joint strength is relatively weak, having a tensile strength of less than about 2700 psi, for example due to formation of a coarse grain structure. The wire **10550** is held by an operator or mechanically anchored to a structure proximal to the distal portion **100**. At the time of detachment, the operator exerts a shear strength on the wire **10550** greater than the tensile strength of the joint (e.g., greater than about 2700 psi) to detach the distal

portion **100** from the proximal portion **200**. Such detachment may be useful, for example, in devices in which the distal portion **100** of a vascular treatment device is desirably detached from the proximal portion **200** at the region of joint **300**, for example, in flow diverters or flow disruptors as described herein.

[0725] In some embodiments, suitable materials for the wire **10550** may include, for example, platinum, titanium, nickel, chromium, cobalt, tantalum, tungsten, iron, manganese, molybdenum, and alloys thereof including nickel titanium (e.g., nitinol), nickel titanium niobium, chromium cobalt, copper aluminum nickel, iron manganese silicon, silver cadmium, gold cadmium, copper tin, copper zinc, copper zinc silicon, copper zinc aluminum, copper zinc tin, iron platinum, manganese copper, platinum alloys, cobalt nickel aluminum, cobalt nickel gallium, nickel iron gallium, titanium palladium, nickel manganese gallium, stainless steel, shape memory alloys, etc. Suitable materials may also include polymers such as polylactic acid (PLA), polyglycolic acid (PGA), poly lactic co-glycolic acid (PLGA), polycaprolactone (PCL), polyorthoesters, polyanhydrides, and copolymers thereof. Suitable materials may also include alloys (e.g., nitinol, chromium cobalt, platinum tungsten, etc.) and combinations of materials (e.g., filaments with a radiopaque core or cladding in combination with a cladding or core, respectively, of a different material, a plurality of filaments including different materials, etc.).

[0726] FIG. 26A is a schematic diagram illustrating still another example embodiment of a joint **3700** between a proximal portion **200** and a distal portion **100**. Such bonding can produce, for example, the device **20** schematically illustrated in FIG. 1B. In contrast to FIGS. 24A, 24B, and 24D, in which the joints **3400**, **3500**, **3600** include the proximal end of the distal portion **100** and the distal end of the proximal portion **200** (e.g., to produce the device **10** schematically illustrated in FIG. 1A), the joint **3700** includes the distal end of the distal portion **100** and the distal end of the proximal portion **200**. The proximal portion **200** extends through the hollow area created by the woven filaments of the distal portion **100**. The proximal portion **200** may still be characterized as proximal because the proximal portion continues to extend proximal to the distal portion **100**. The joint **3700** may comprise the features of the joints **3400**, **3500**, **3600** (e.g., bonding material **320** and/or the sleeve **330**).

[0727] In some embodiments, the distal ends of the filaments of the distal portion **100** may be configured to be positioned in the distal end of the proximal portion **100** (e.g., by curling radially inward). In certain such embodiments, the joint **3700** may comprise the features of the joints **3000**, **3100**, **3200**, **3300** (e.g., bonding material, a compression sleeve, a compression ring, etc.).

[0728] In some embodiments, the proximal end of the distal portion **100** is not coupled to the proximal portion **200** (e.g., the proximal end of the distal portion **100** is free to move longitudinally along the proximal portion **200**). In some embodiments, the proximal neck of the distal portion **100** is long (e.g., greater than about 5 mm) to inhibit unsheathing of the entire distal portion **100** during a procedure. In some embodiments, the proximal end of the distal portion **100** comprises a radiopaque marker band **1720**, for example as described herein, which can warn against and/or help inhibit unsheathing of the entire distal portion **100** during a procedure.

[0729] In some embodiments, the proximal portion 200 of a device 20 is the same other the proximal portions 200 described herein. In some embodiments, the proximal portion 200 of a device 20 includes a longer distal-most segment to account for the length of the distal portion 100 (e.g., a 41 mm distal-most cut section of the proximal portion 200 may be about 101 mm).

[0730] The device 20 may be useful for hard clots, aged clots, and/or clots including embedded plaque, for example because the entire longitudinal length of the distal portion 100 is reinforced with the strength of the proximal portion 200 and/or because proximal portion 200 can provide more direct torsional rasping to the entire length of the distal portion 100 rather than the torque being diluted along the length of the distal portion 100 with distance from the proximal portion 200 in a device 10. The device 10 may be useful for acute clots and/or clots that are relatively new.

[0731] FIG. 26B is a schematic diagram illustrating yet still another example embodiment of a joint 3750 between a proximal portion 100 and a distal portion 200. Such bonding can produce, for example, the device 30 schematically illustrated in FIG. 1C. In contrast to FIGS. 24A, 24B, and 24D, in which the joints 3400, 3500, 3600 include the proximal end of the distal portion 100 and the distal end of the proximal portion 200 (e.g., to produce the device 10 schematically illustrated in FIG. 1A), the joint 3750 includes an intermediate part of the distal portion 100 and the distal end of the proximal portion 200. The proximal portion 200 extends through the hollow area created by the woven filaments of the distal portion 100 proximal to the joint 3750. The proximal portion 200 may still be characterized as proximal because the proximal portion continues to extend proximal to the distal portion 100. The joint 3750 may comprise the features of the joints 3400, 3500, 3600 (e.g., bonding material 320 and/or the sleeve 330) and other joints described herein.

[0732] In some embodiments, the proximal end of the distal portion 100 is not coupled to the proximal portion 200 (e.g., the proximal end of the distal portion 100 is free to move longitudinally along the proximal portion 200). In some embodiments, the proximal neck of the distal portion 100 is long (e.g., greater than about 5 mm) to inhibit unsheathing of the entire distal portion 100 during a procedure. In some embodiments, the proximal end of the distal portion 100 comprises a radiopaque marker band 1720, for example as described herein, which can warn against and/or help inhibit unsheathing of the entire distal portion 100 during a procedure. In some embodiments, the proximal portion 200 includes a longer distal-most segment to account for the length of the distal portion 100 through which the proximal portion 100 extends (e.g., a 41 mm distal-most cut section of the proximal portion 200 may be about 81 mm).

[0733] FIG. 26C is a schematic diagram illustrating another example embodiment of a joint 3775 between a proximal portion 100 and a distal portion 200. Such bonding can produce, for example, the device 40 schematically illustrated in FIG. 1D. In contrast to FIGS. 24A, 24B, and 24D, in which the joints 3400, 3500, 3600 include the proximal end of the distal portion 100 and the distal end of the proximal portion 200 (e.g., to produce the device 10 schematically illustrated in FIG. 1A), the joint 3775 includes the distal end of the distal portion 100 and an intermediate part of the proximal portion 200. The proximal portion 200 extends through the hollow area created by the woven filaments of the distal portion 100 and distal to the distal end of the distal portion 100. The

proximal portion 200 may still be characterized as proximal because the proximal portion continues to extend proximal to the distal portion 100. The joint 3775 may comprise the features of the joints 3400, 3500, 3600 (e.g., bonding material 320 and/or the sleeve 330) and other joints described herein.

[0734] In some embodiments, the proximal end of the distal portion 100 is not coupled to the proximal portion 200 (e.g., the proximal end of the distal portion 100 is free to move longitudinally along the proximal portion 200). In some embodiments, the proximal neck of the distal portion 100 is long (e.g., greater than about 5 mm) to inhibit unsheathing of the entire distal portion 100 during a procedure. In some embodiments, the proximal end of the distal portion 100 comprises a radiopaque marker band 1720, for example as described herein, which can warn against and/or help inhibit unsheathing of the entire distal portion 100 during a procedure. In some embodiments, the proximal portion 200 includes a longer distal-most segment to account for the length of the distal portion 100 and the extension of the proximal portion 100 beyond the distal portion 200 (e.g., a 41 mm distal-most cut section of the proximal portion 200 may be about 141 mm).

[0735] In some embodiments, the distal portion 100 may be joined to the proximal portion 200 between the proximal end of the distal portion 100 and the distal end of the distal portion 100. For example, the joint 300 may be along the neck between the distal-most bulb and the next most distal bulb. Certain such embodiments can provide the benefits of the device 20 and a distal bulb that can provide embolic protection without a separate distal embolic protection device. For another example, the joint 300 may be in an intermediate portion of the distal portion 100, which can provide a smaller diameter in a distal section of the distal portion 100 (e.g., useful for traversing to smaller vessels), which can provide embolic filtering, and/or which can provide structural reinforcement in a proximal section of the distal portion 100.

[0736] After joining the distal portion 100 and the proximal portion 200, the entire distal portion 100 and about 50% of the proximal portion 100 may be placed within an introducer sheath. The introducer sheath maintains the distal portion 100 in the contracted or constrained position, and can inhibit the distal section of the proximal portion 200 that it surrounds from kinking. In some embodiments, the introducer sheath comprises a biomedical polymer, for example silicone, polyurethane (e.g., Polyslix, available from Duke Extrusion of Santa Cruz, Calif.), polyethylene (e.g., Rexell®, available from Huntsman) including low density polyethylene (LDPE), linear low density polyethylene (LLDPE), medium density polyethylene (MDPE), and high density polyethylene (HDPE), fluoropolymers such as fluorinated ethylene propylene, PFA, MFA, PVDF, THV, ETFE, PCTFE, ECTFE (e.g., Teflon® FEP, available from DuPont), polypropylene, polyesters including polyethylene terephthalate (PET), PBT, PETG (e.g., Hytrel®, available from DuPont), PTFE, combination polymer compounds such as thermoplastic polyurethanes and polyether block amides (e.g., Propell™, available from Foster Corporation of Putnam, Conn.), polyether block amides (e.g. Pebax®, available from Arkema of Colombes, France, Pebaslix, available from Duke Extrusion of Santa Cruz, Calif.), polyether soft blocks coupled with polyester hard blocks vinyls such as PVC, PVDC, polyimides (e.g., polyimides available from MicroLumen of Oldsmar, Fla.), polyamides (e.g., Durethan, available from Bayer, Nylon 12, available from Duke Extrusion of Santa Cruz, Calif.), poly-

carbonate (e.g., Corethane™, available from Corvita Corp. of Miami, Fla.), styrenics such as PS, SAN, ABS, and HIPS, acetals such as copolymers or homopolymers, high temperature performance polymers such as PEEK, PES, PPS, PSU, LCP, combinations thereof, and the like. The introducer sheath may have a tapered tip or a straight tip.

**[0737]** In some embodiments, a kit comprises a vascular treatment device at least partially within an introducer sheath. The vascular treatment device includes a distal portion **100** and a proximal portion **200**. The distal portion **100** may be in a radially compressed state within the introducer sheath. The distal portion **100** and the proximal portion **200** are coupled at a joint **300**. The joint may be reversible or non-reversible. The kit may further comprise tubing in a spiral pattern configured to contain the introducer sheath and/or a thrombus measurement guide (e.g., as illustrated in FIG. 27N). The thrombus measurement guide may be on a backing configured to hold the tubing in the spiral pattern in a plane. Multiple planes are possible for longer vascular treatment devices and/or dimensionally smaller kits.

**[0738]** In some embodiments, the introducer sheath has a length that is between about 10% and about 50% of the length of the proximal portion **200**. In some embodiments, the introducer sheath has a length between about (e.g., about 105 cm). In some embodiments, the introducer sheath has an inner diameter between about 0.5 mm and about 0.5 mm (e.g., about 0.0165 inches (approx. 0.42 mm)). In some embodiments, the introducer sheath has an outer diameter between about 0.5 mm and about 0.75 mm (e.g., about 0.024 inches (approx. 0.61 mm)). In some embodiments, the introducer sheath has an inner diameter that is at least about 0.002 inches (approx. 0.05 mm) greater than the outer diameter of the proximal portion **200** and/or the distal portion **100** in the collapsed configuration, which can inhibit or prevent premature deployment of the distal portion **100** and/or allow easier advancing of the distal portion **100**. In some embodiments, the introducer sheath has an inner diameter that is at least about 0.002 inches (approx. 0.05 mm) greater than the outer diameter of the proximal portion **200** and/or the distal portion **100** in the collapsed configuration, which can inhibit or prevent premature deployment of the distal portion **100** and/or allow easier advancing of the distal portion **100** in the collapsed configuration. In some embodiments, the introducer sheath has an inner diameter that is no greater about 0.002 inches (approx. 0.05 mm) greater than the inner diameter of the delivery catheter or microcatheter, which can allow smooth advancing of the distal portion **100** in the collapsed configuration from the introducer sheath to the microcatheter. In some embodiments, the introducer sheath has a wall thickness between about 0.002 inches (approx. 0.05 mm) and about 0.006 inches (approx. 0.15 mm), which can inhibit or prevent kinking of the introducer sheath and/or protect the distal portion **100**.

**[0739]** The device (the distal portion **100** and the proximal portion **200**) and the introducer sheath may be placed in a protective spiral loop to inhibit any portion of the device from kinking, and then sealed in a pouch (e.g., comprising high density polyethylene). The pouch and its contents may be sterilized by gamma radiation and/or chemical treatment (e.g., ethylene oxide gas), and then placed in a box for shipping.

**[0740]** In some embodiments, the box includes a length scale. After a procedure, a user can lay a clot next to the scale to measure the length of clot. Such a measurement can help

verify that the length of the removed clot is at least as long as the length of the clot as measured prior to the removal procedure. If the length of the measure clot is less than expected, the user might check the aspiration syringe for additional clot. Certain process, such as torsional rasping described herein, can substantially maintain the length of the clot for accurate measurement, whereas other processes, for example in which a clot is macerated, eliminate the possibility of such measurement or cause the user to try to stack the various pieces of the removed clot, which can be inaccurate.

**[0741]** The devices **10**, **20**, **30**, **40** described herein may be used for thrombectomy, for example according to the procedures described below, but can also be used as an embolic filter, for example during an angioplasty, aspiration, stenting, or other vascular procedure such as flow diversion or flow disruption (e.g., as described herein).

**[0742]** Prior to performing a thrombectomy procedure, a subject having a clot is identified. Subjects showing at least one of ten symptoms of stroke receive a computerized axial tomography (CAT) scan. The CAT scan shows if there is bleeding or no bleeding. If there is bleeding, then the area outside vasculature shows up as hyperdense or bright. If there is no bleeding, then the clot or blockage shows up as hyperdense or bright.

**[0743]** If there is a clot, the length of the clot can be measured, for example, by at least one of: (1) CAT scan print and scale or digital imaging measurement (PACS); (2) CAT scan angiogram where about 50 cm<sup>3</sup> to about 100 cm<sup>3</sup> of dye comprising iodine (e.g., iohexyl, iodixanol, etc.) are injected into a forearm vein IV and pictures of neuro blood vessels are taken; (3) magnetic resonance imaging (MRI) angiogram where 20 cm<sup>3</sup> to about 40 cm<sup>3</sup> of gadolinium are injected into a forearm vein IV and picture are taken of neuro blood vessels, which can also provide images of the health of brain tissue; and (4) catheter angiogram, in which a guide catheter (e.g., having a length of about 80 cm to about 95 cm and an outer diameter of about 5 Fr to about 9 Fr (about 1.67 mm to about 3 mm)) is routed from a femoral artery to a carotid or vertebral artery, then dye comprising iodine (e.g., iohexyl, iodixanol, etc.) is injected for direct imaging of the clot site, which is generally considered the most accurate of these four methods. Other measurement methods are also possible.

**[0744]** When using catheter angiogram for peripheral (e.g., leg) blockages, the guide catheter may be routed from the non-affected leg into the affected leg (e.g., contrafemoral access), which allows the puncture to be in the direction of the head so that blood flow can heal any dissection of the vessel. In some embodiments, the guide catheter of the catheter angiogram can be used for a treatment procedure, providing a general continuity between diagnosis and treatment.

**[0745]** Clots in neurovasculature are generally between about 5 mm and about 55 mm, although other clot lengths are also possible. Clots in peripheral (e.g., leg) vessels are generally between about 25 mm and about 90 mm, although other clot lengths are also possible.

**[0746]** After measurement, certain criteria can be used to determine whether a clot is a candidate for removal, such as the last time the patient was seen acting normal (e.g., removal candidate if less than 12 hours ago), the National Institutes of Health (NIH) stroke scale (e.g., removal candidate if greater than 10), imaging shows that a large vessel is blocked (e.g., removal candidate if large vessel blocked, which could affect many branch vessels), and/or imaging shows a small area of

loss of tissue and/or a large area of tissue that can be salvaged. A clot that is a candidate for removal can then be removed.

**[0747]** The femoral artery can act as a percutaneous entry point. As described above with respect to the catheter angiogram, for removal of a neurovascular clot, either leg can be used because both point towards the head, and, for removal of a peripheral clot, the non-affected leg can be used. A guide catheter is partially inserted into the entry point. In some embodiments, the guide catheter may have a length between about 80 cm and about 95 cm, an inner diameter between about 5 Fr and about 9 Fr (between about 1.67 mm and about 3 mm), and an outer diameter between about 6 Fr and about 10 Fr (between about 2 mm and about 3.3 mm). A tapered dilator may extend about 1 inch to about 1.5 inches (approx. 2.5 cm to about 3.8 cm) out of the distal end of the guide catheter for easier navigation.

**[0748]** A first steerable guidewire (e.g., having a length between about 150 cm and about 180 cm) is inserted into the guide catheter and the dilator, extending some distance (e.g., about 2 inches (approx. 5 cm) out of the distal end of the dilator. The steerable guidewire can be advanced and steered for some distance, followed by advancement of the guide catheter and dilator over the guidewire. The guidewire and the guide catheter can be sequentially advanced until the desired point in the vasculature (e.g., the descending aorta). The dilator and guidewire are removed, but the guide catheter is left in place. The desired point of the vasculature where advancement ceases may be the point where further advancement of the dilator could perforate the vasculature.

**[0749]** A diagnostic catheter (e.g., having a length between about 100 cm and about 125 cm (e.g., about 10 cm to about 20 cm longer than the guide catheter)) having an outer diameter smaller than the inner diameter of the guide catheter (e.g., about 5 Fr (about 1.67 mm) when the guide catheter has an inner diameter of about 5 Fr and about 9 Fr (between about 1.67 mm and about 3 mm)) and an inner diameter that can accept a steerable guidewire (e.g., a guidewire having a diameter of about 0.035 inches (approx. 0.9 mm)) (e.g., between about 3 Fr (about 1 mm) and about 4 Fr (about 1.33 mm)) is then inserted into the guide catheter.

**[0750]** A second steerable guidewire (e.g., having a length between about 150 cm and about 180 cm), which may be the same as the first steerable guidewire or a different steerable guidewire, is inserted into the diagnostic catheter, extending some distance (e.g., about 2 inches (approx. 5 cm) out of the distal end of the diagnostic catheter. The steerable guidewire can be advanced and steered for some distance, followed by advancement of the diagnostic catheter over the guidewire. The guidewire and the diagnostic catheter can be sequentially advanced until the desired point in the vasculature (e.g., a carotid artery, a vertebral artery), which may be about three inches (e.g., about 7.6 cm) distal to the distal end of the guide catheter. The dilator and guidewire are removed, but the guide catheter is left in place. The guide catheter is then advanced over the diagnostic catheter to a desired position (e.g., slightly proximal to the distal end of the diagnostic catheter). The diagnostic catheter and guidewire are removed, but the guide catheter is again left in place. The guide catheter may remain in this location for substantially the remainder of the procedure.

**[0751]** FIG. 27A is a schematic diagram of a guide catheter **502** proximal to a thrombus (e.g., clot) **500** in vasculature (e.g., the thrombus **500** in the right middle cerebral artery and the guide catheter **502** in the right internal carotid artery), for

example having been routed to that position as described above. The thrombus **500** may have been noted during angiography with the guide catheter **502** or another catheter (e.g., a shuttle or a balloon guide catheter), for example in the right internal carotid artery. A catheter angiogram may be performed using the guide catheter **502** after positioning the guide catheter **502**.

**[0752]** In some embodiments, the guide catheter **502** may have a length between about 45 cm and about 125 cm, between about 45 cm and about 80 cm (e.g., about 55 cm) (e.g., for use in peripheral vasculature), between about 80 cm and about 100 cm (e.g., about 100 cm) (e.g., for use in coronary vasculature), between about 80 cm and about 125 cm (e.g., about 95 cm) (e.g., for use in neurovasculature). The guide catheter **502** may have a wall thickness between about 0.002 inches (approx. 0.05 mm) and about 0.04 inches (approx. 1 mm), which can allow for incorporating the proximal portion **200** within the walls of the guide catheter **502**. The guide catheter **502** may comprise a biomedical polymer, for example silicone, polyurethane (e.g., Polyslix, available from Duke Extrusion of Santa Cruz, Calif.), polyethylene (e.g., Rexell®, available from Huntsman) including low density polyethylene (LDPE), linear low density polyethylene (LLDPE), medium density polyethylene (MDPE), and high density polyethylene (HDPE), fluoropolymers such as fluorinated ethylene propylene, PFA, MFA, PVDF, THV, ETFE, PCTFE, ECTFE (e.g., Teflon® FEP, available from DuPont), polypropylene, polyesters including polyethylene terephthalate (PET), PBT, PETG (e.g., Hytre®, available from DuPont), PTFE, combination polymer compounds such as thermoplastic polyurethanes and polyether block amides (e.g., Propell™, available from Foster Corporation of Putnam, Conn.), polyether block amides (e.g. Pebax®, available from Arkema of Colombes, France, PebaSlix, available from Duke Extrusion of Santa Cruz, Calif.), polyether soft blocks coupled with polyester hard blocks vinyls such as PVC, PVDC, polyimides (e.g., polyimides available from MicroLumen of Oldsmar, Fla.), polyamides (e.g., Durethan, available from Bayer, Nylon 12, available from Duke Extrusion of Santa Cruz, Calif.), polycarbonate (e.g., Corethane™, available from Corvita Corp. of Miami, Fla.), styrenics such as PS, SAN, ABS, and HIPS, acetals such as copolymers or homopolymers, high temperature performance polymers such as PEEK, PES, PPS, PSU, LCP, combinations thereof, and the like.

**[0753]** The guide catheter **502** may comprise a hypotube (e.g., an uncut hypotube and/or a hypotube cut with a plurality of interspersed offset patterns as described herein) and/or a plurality of filaments (e.g., woven, knitted, spiraled, etc.) as reinforcement, for example in combination with a polymer inward and/or outward thereof. As described herein, certain cut patterns may inhibit pinching to such a degree that polymer may be omitted. In some embodiments, the guide catheter **502** may include a long sheath, a shuttle, and/or a balloon guide catheter.

**[0754]** In some embodiments, the guide catheter **502** comprises a hypotube including a cut pattern, for example as described herein with respect to the proximal portion **200** and catheters comprising the proximal portion **200**, for example to inherit the maneuverability advantages that may be provided by the proximal portion **200** (e.g., to facilitate proximal support and distal flexibility). In some embodiments, the guide catheter **502** comprises a parameter (e.g., slot pitch) that varies from proximal to distal. For example, the pitch



between slots and/or windings of a spiral may vary, from the distal end to the proximal end, as follows: about 0.005 inches (approx. 0.13 mm), about 0.01 inches (approx. 0.25 mm), about 0.02 inches (approx. 0.51 mm), about 0.04 inches (approx. 1 mm), about 0.08 inches (approx. 2 mm), and about 0.16 inches (approx. 4 mm). For another example, the pitch between slots and/or windings of a spiral may vary, from the distal end to the proximal end, as follows: about 0.005 inches (approx. 0.13 mm) for the distal-most about 20%, about 0.01 inches (approx. 0.25 mm) for the next about 15%, about 0.02 inches (approx. 0.51 mm) for the next about 15%, about 0.04 inches (approx. 1 mm) for the next about 15%, about 0.08 inches (approx. 2 mm) for the next about 15%, and about 0.16 inches (approx. 4 mm) for the next (or proximal-most) about 20%.

[0755] The guide catheter **502** may comprise a radiopaque marker (e.g., a radiopaque marker band as described herein) at a distal end and/or at regular intervals (e.g., between about 0.1 mm and about 50 mm, between about 0.5 mm and about 1 mm, between about 1 mm and about 2 mm, between about 2 mm and about 3 mm, between about 3 mm and about 4 mm, between about 4 mm and about 5 mm, between about 5 mm and about 8 mm, between about 8 mm and about 10 mm, between about 10 mm and about 12 mm, between about 12 mm and about 15 mm, between about 15 mm and about 25 mm, between about 25 mm and about 35 mm, between about 35 mm and about 50 mm apart, including overlapping ranges thereof), which can help to visualize the guide catheter **502** and assist in measuring clot length or vessel diameter, or lesion length or by serving as a surrogate marker for a measurement tool.

[0756] FIG. 27B is a schematic diagram of a microwire **506** distal to a thrombus (e.g., clot) **500** in vasculature and a microcatheter **504** over the microwire **506**. FIG. 27C is an expanded view of FIG. 27B in the area of the thrombus **500**. A microcatheter **504** having an outer diameter smaller than the inner diameter of the guide catheter **502** and an inner diameter that can accept a steerable microwire **506** (e.g., a guidewire having a diameter of about 0.014 inches (approx. 0.36 mm)) (e.g., between about 0.0165 inches (approx. 0.42 mm) and about 0.017 inches (approx. 0.43 mm)) is then inserted into the guide catheter **502**. Microcatheters used for other thrombectomy devices generally have an internal diameter of 0.021 inches (approx. 0.53 mm), although other inner diameters are also possible (e.g., about 0.014 inches (approx. 0.36 mm) about 0.017 inches (approx. 0.43 mm), about 0.027 inches (approx. 0.69 mm)). The microcatheter **504** may have a wall thickness between about 0.00075 inches (approx. 0.02 mm) and about 0.04 inches (approx. 1 mm), which can allow for incorporating the proximal portion **200** within the walls of the microcatheter **504**. A smaller diameter microcatheter **504** can be easier and/or faster to route over a microwire **506**, which can reduce procedure time. The microcatheter **504** may have a length between about 80 cm and about 210 cm, between about 80 cm and about 120 cm (e.g., for use in peripheral vasculature), between about 120 cm and about 150 cm (e.g., for use in coronary vasculature), between about 150 cm and about 210 cm (e.g., about 180 cm) (e.g., for use in neurovasculature).

[0757] The microcatheter **504** may comprise a biomedical polymer, for example silicone, polyurethane (e.g., Polyslix, available from Duke Extrusion of Santa Cruz, Calif.), polyethylene (e.g., Rexell®, available from Huntsman) including low density polyethylene (LDPE), linear low density poly-

ethylene (LLDPE), medium density polyethylene (MDPE), and high density polyethylene (HDPE), fluoropolymers such as fluorinated ethylene propylene, PFA, MFA, PVDF, THV, ETFE, PCTFE, ECTFE (e.g., Teflon® FEP, available from DuPont), polypropylene, polyesters including polyethylene terephthalate (PET), PBT, PETG (e.g., Hytrel®, available from DuPont), PTFE, combination polymer compounds such as thermoplastic polyurethanes and polyether block amides (e.g., Propell™, available from Foster Corporation of Putnam, Conn.), polyether block amides (e.g., Pebax®, available from Arkema of Colombes, France, Pebaslix, available from Duke Extrusion of Santa Cruz, Calif.), polyether soft blocks coupled with polyester hard blocks vinyls such as PVC, PVDC, polyimides (e.g., polyimides available from MicroLumen of Oldsmar, Fla.), polyamides (e.g., Durethan, available from Bayer, Nylon 12, available from Duke Extrusion of Santa Cruz, Calif.), polycarbonate (e.g., Corethane™, available from Corvita Corp. of Miami, Fla.), styrenics such as PS, SAN, ABS, and HIPS, acetals such as copolymers or homopolymers, high temperature performance polymers such as PEEK, PES, PPS, PSU, LCP, combinations thereof, and the like.

[0758] The microcatheter **504** may comprise a hypotube (e.g., an uncut hypotube and/or a hypotube cut with a plurality of interspersed offset patterns as described herein) and/or a plurality of filaments (e.g., woven, knitted, spiraled, etc.) as reinforcement, for example in combination with a polymer inward and/or outward thereof. As described herein, certain cut patterns may inhibit pinching to such a degree that polymer may be omitted.

[0759] The microcatheter **504** may comprise a radiopaque marker (e.g., a radiopaque marker band as described herein) at a distal end and/or at regular intervals (e.g., between about 0.1 mm and about 50 mm, between about 0.5 mm and about 1 mm, between about 1 mm and about 2 mm, between about 2 mm and about 3 mm, between about 3 mm and about 4 mm, between about 4 mm and about 5 mm, between about 5 mm and about 8 mm, between about 8 mm and about 10 mm, between about 10 mm and about 12 mm, between about 12 mm and about 15 mm, between about 15 mm and about 25 mm, between about 25 mm and about 35 mm, between about 35 mm and about 50 mm apart, including overlapping ranges thereof), which can help to visualize the microcatheter **504** and assist in measuring clot length by serving as a surrogate marker for a measurement tool.

[0760] A steerable microwire **506** (e.g., having an outer diameter of about 0.014 inches (approx. 0.36 mm)) is inserted into the microcatheter **504**, extending some distance (e.g., about 2 cm to about 4 cm) out of the distal end of the microcatheter **504**. The microwire **506** can be advanced and steered for some distance, followed by advancement of the microcatheter **504** over the microwire **506**. The microwire **506** and the microcatheter **504** can be sequentially advanced until the desired point in the vasculature (e.g., distal to the clot by about 0.5 mm to about 5 mm). FIG. 27D is a schematic diagram of a microcatheter **504** distal to a thrombus (e.g., clot) **500** in vasculature (e.g., the thrombus **500** in the right middle cerebral artery).

[0761] In some embodiments, the microwire **506** can cross the clot, for example by slicing through a middle part of the clot. If the clot is hard or is difficult for the microwire **506** to traverse, the microwire **506** may be used as a launching pad to guide advance the microcatheter **504** past the clot and the microwire **506**. In certain such embodiments, the microcath-

eter **504** does not traverse the clot. In some embodiments, the microcatheter **504** may have a distal end configured to traverse hard clots (e.g., a generally rigid cylinder). In some embodiments, for example in which the lesion is calcified (e.g., heavily calcified), a thrombolytic and/or crossing device may aid the microwire **506** and/or microcatheter **504** across the clot.

[0762] FIG. 27D is a schematic diagram of a microcatheter **504** distal to a thrombus (e.g., clot) **500** in vasculature. Once the microcatheter **504** is distal to the thrombus **500**, the microwire **506** is removed or retracted, and the microcatheter **504** is left in place, with the distal end of the microcatheter **504** distal to the distal end of the thrombus **500**.

[0763] A dye comprising iodine (e.g., iohexyl, iodixanol, etc.) can be injected into the microcatheter **504** and/or between the guide catheter and the microcatheter **504**, for example to help to define the proximal and distal ends of the thrombus **500**. The length and diameter of the thrombus **500** can be measured, from which the volume of the thrombus **500**, or the clot burden, can be calculated.

[0764] In some systems using a microcatheter (e.g., a microcatheter having an internal diameter of 0.021 inches (approx. 0.53 mm)), a thrombectomy device, for example being laser cut for that purpose or an adapted laser-cut stent, having a set length is advanced to remove the clot piecemeal. For example, if the length of the thrombectomy device is 5 mm and the length of the clot is 15 mm, at least three removal procedures are needed. The thrombectomy device generally must be fully removed from the body to clear the captured clot piece, and removal of each clot piece can take up to about forty minutes. For clots in neurovasculature, about 1,900,000 brain cells die per minute. Thus, for a three-part removal process where each removal takes forty minutes, about 228,000,000 brain cells could die. If the diameter of the vasculature varies, or if one thrombectomy device is otherwise not suitable for removing each piece of the clot, multiple thrombectomy devices may be used, which can greatly increase the cost of the procedure. Users may sometimes opt to remove less than the full clot to reduce procedure time and/or the number of thrombectomy devices used, or in some cases may choose to not retrieve a clot at all due to knowledge that multiple removal iterations and/or thrombectomy devices will be needed. Such practices can produce unacceptable results for patients, doctors, and hospitals.

[0765] FIG. 27E is a schematic diagram illustrating an example embodiment of the distal portion **100** of a vascular treatment device being introduced into the hub **590** of a microcatheter **504** through an introducer sheath **540**. Referring again to the devices **10**, **20**, **30**, **40** described herein, the introducer sheath **540** is placed into a funnel-shaped proximal end **590** of the microcatheter **504**, which is in the guide catheter **502**. In some embodiments, the proximal end **590** of the microcatheter **504** is placed into the proximal end of a Y-connector **592** including a valve (e.g., a rotating hemostatic valve) to allow flushing (e.g., with saline) before, during, and/or after advancing the device **10**, **20**, **30**, **40**. The distal end of the Y-connector **592** may be attached to the proximal end of the guide catheter **502**. The proximal portion **200** is pushed to advance the device **10**, **20**, **30**, **40** through the microcatheter **504**, with the distal portion **100** in the constrained state. The introducer sheath **540** can inhibit kinking of the proximal portion **200** during this insertion. The introducer sheath **540** can be retracted relative to the proximal portion **200** to unsheath the proximal portion **200**. In some

embodiments, a radiopaque marker (e.g., the radiopaque marker bands **25**, **1720** described herein) can be used to track the progress of the advancement of the device **10**, **20**, **30**, **40** and/or portions thereof. For example, in some embodiments, the microcatheter **504** may include a radiopaque marker (e.g., marker band) at a distal tip, and the location of the radiopaque marker of the device **10**, **20**, **30**, **40** can be compared thereto.

[0766] In some embodiments, the microcatheter **504** is reinforced with the proximal portion **200**, for example to inherit the maneuverability advantages of the proximal portion **200** (e.g., to facilitate proximal support and distal flexibility). In some embodiments, the microcatheter **504** comprises a parameter (e.g., slot pitch) that varies from proximal to distal. For example, the pitch between slots and/or windings of a spiral may vary, from the distal end to the proximal end, as follows: about 0.005 inches (approx. 0.13 mm), about 0.01 inches (approx. 0.25 mm), about 0.02 inches (approx. 0.51 mm), about 0.04 inches (approx. 1 mm), about 0.08 inches (approx. 2 mm), and about 0.16 inches (approx. 4 mm). For another example, the pitch between slots and/or windings of a spiral may vary, from the distal end to the proximal end, as follows: about 0.005 inches (approx. 0.13 mm) for the distal-most 20%, about 0.01 inches (approx. 0.25 mm) for the next 15%, about 0.02 inches (approx. 0.51 mm) for the next 15%, about 0.04 inches (approx. 1 mm) for the next 15%, about 0.08 inches (approx. 2 mm) for the next 15%, and about 0.16 inches (approx. 4 mm) for the next (or proximal-most) 20%.

[0767] FIG. 27F is a schematic partial cross-sectional view of an example embodiment of a distal portion **100** of a vascular treatment device within an introducer sheath **540**. The introducer sheath includes a tapered distal end **545** configured to mate with the funnel-shaped portion of the proximal end **590** of a microcatheter **504**. When the distal portion **100** is within the introducer sheath **540**, and when the distal portion **100** is within the microcatheter **504**, the distal portion **100** is in a collapsed state (e.g., a tubular state without bulbs).

[0768] The device **10**, **20**, **30**, **40** is advanced until the distal end of the distal portion **100** is proximate to the distal end of the microcatheter **504**, which is distal to the distal end of the thrombus **500**. The microcatheter **504** is then retracted (e.g., unsheathed, unsheathed) while holding the proximal portion **200** still so that the longitudinal position of the device **10**, **20**, **30**, **40** is maintained. FIG. 27G is a schematic diagram of part of a distal portion **100** of a vascular treatment device **10**, **20**, **30**, **40** being deployed distal to a thrombus (e.g., clot) **500** in vasculature. The retraction of the microcatheter **504** exposes the distal portion **100**, from the distal end back, which allows the exposed sections of the distal portion **100** to self-expand. For example, the distal neck **65** and the distal-most bulb can expand.

[0769] In some embodiments, self-expansion of the exposed sections of the distal portion **100** at least partially because the distal portion **100** includes at least some super-elastic filaments that can, for example, self-expand due to stress-induced martensite (SIM) without any particular change in temperature. Super-elastic materials can expand substantially instantaneously from a collapsed configuration to an expanded configuration when the unsheathed. In some embodiments, self-expansion of the exposed sections of the distal portion **100** is at least partially because the distal portion **100** includes at least some shape memory filaments that can, for example, self-expand due to heat-activated austenitic transformation (e.g., upon a particular change in temperature

such as greater than room temperature (about 25° C.), about body temperature (approx. 37° C.), etc.). Shape-memory materials can expand slowly from a collapsed configuration to an expanded configuration when unsheathed upon contact with warm fluid (e.g., blood at body temperature, warm saline).

[0770] In some embodiments, the shape memory effect of the shape memory filaments can be one-way (e.g., a stress-induced change in shape returns to a baseline shape upon heating, while there is no further change upon cooling). The material remembers one shape with the one-way shape memory effect, the shape at high temperature. In some embodiments, the shape memory effect of the shape memory filaments can be two-way (e.g., a stress-induced change in shape returns close to baseline shape upon heating, while a second shape can be achieved upon cooling). The material remembers two shapes with the two-way shape memory effect, a first shape at high temperature and a second shape at low temperature.

[0771] In some embodiments, the length of the retraction of the microcatheter 504, and the amount of the distal portion 100 exposed, can be related to the length of the thrombus 500, for example as measured as described above. For example, the microcatheter 504 can be retracted until a bulb is proximal to the proximal end of the thrombus 500.

[0772] The length of the distal portion 100 and/or number of bulbs that can be unsheathed to treat a thrombus (e.g., clot) 500 is customizable for each thrombus 500. For example, if using the distal portion 1100 described above to treat a 10 mm thrombus 500, the distal-most bulb 1112 could be deployed distal to the thrombus 500, then the next two bulbs 1112, then the distal bulb 1114 could be deployed proximal to the thrombus 500, while the other two bulbs 1114 and the bulbs 1116, 1118 remain in the microcatheter 504. For another example, if using the distal portion 1100 described above to treat a 40 mm thrombus 500, the distal-most bulb 1112 could be deployed distal to the thrombus 500, then the next five bulbs 1112, 1114, 1116, then the distal bulb 1118 could be deployed proximal to the thrombus 500, while the proximal-most bulb 1118 remains in the microcatheter 504. Such customizability can advantageously improve at least one of the drawbacks to treating clots 500 with other thrombectomy devices described above (e.g., treatment time, multiplied costs, user reluctance, etc.).

[0773] In some embodiments, if one bulb cannot fully entrap the thrombus (e.g., clot) 500, another bulb (whether the same or different in size and/or shape) and/or a plurality of bulbs can entrap the thrombus 500. In some embodiments, the undulations (e.g., the hills and valleys created by the bulbs and/or at the micro level by the braiding pattern) facilitate thrombus 500 entrapment. Undulating and/or dual undulation may enhance scraping of sidewalls and thrombus 500 entrapment. The thrombus 500, once entrapped or captured by the bulbs, can be removed as the thrombectomy device 10, 20, 30, 40 is removed from the subject. Particles that break off from the clot (e.g., emboli) can be captured by at least one bulb (including, but not limited to, the distal-most bulb(s)).

[0774] The procedures described herein are not limited to deploying parts of the distal portion 100 based on an initial thrombus (e.g., clot) size measurement. In some embodiments, the length of the thrombus 500 is not measured. In some embodiments, the number of bulbs deployed can help

measure the length of the thrombus 500 as the procedure is occurring (e.g., using radiopaque markers, using radiopaque strand helix crossings, etc.).

[0775] As the distal portion 100 expands radially outwardly, some parts of the thrombus (e.g., clot) 500 are pushed towards the vessel sidewalls and some parts of the thrombus 500 are trapped between bulbs of the distal portion 100. Some parts of the thrombus 500 may also be trapped between filament crossings of the distal portion 100. FIG. 27H is a schematic diagram of a distal portion 100 of a vascular treatment device being deployed across a thrombus 500 in vasculature.

[0776] FIG. 27I-1 is a schematic diagram illustrating an example embodiment of the distal portion 100 of a vascular treatment device being used in conjunction with thrombus aspiration. In some embodiments, referring again to FIG. 27A, a distal access microcatheter 530 and a microcatheter 504 inserted inside the distal access microcatheter 530 may be advanced over a steerable microwire 506 and through a guide catheter 502 positioned proximal to the thrombus 500. A steerable microwire 506 (e.g., having an outer diameter of about 0.014 inches (approx. 0.36 mm)) is inserted into the microcatheter 504, extending some distance (e.g., about 2 cm to about 4 cm) out of the distal end of the microcatheter 504. The microwire 506 can be advanced and steered for some distance, followed by advancement of the microcatheter 504 over the microwire 506, followed by advancement of the distal access microcatheter 530 over the microcatheter 504. The microwire 506, the microcatheter 504, and the distal access microcatheter 530 can be sequentially advanced until the desired point in the vasculature (e.g., distal to the clot or lesion by about 0.5 mm to about 5 mm for the microcatheter 504, and proximal to the clot or lesion by about 0.5 mm to about 15 cm for the distal access microcatheter 530). FIG. 27I-1 schematically shows the distal access microcatheter 530 proximal to a thrombus (e.g., clot) 500 in vasculature (e.g., in the right middle cerebral artery). The microcatheter 504 is also proximal to the thrombus 500 and the distal portion 100 of the device 10, 20, 30 or 40 has been deployed across the entire length of the thrombus 500.

[0777] The distal access microcatheter 530 may provide proximal support to the microcatheter 504 and/or for aspiration. In some embodiments, the distal end of the distal access microcatheter 530 includes a balloon, and the distal access microcatheter 530 may be used like a balloon guide catheter, for example to provide temporary flow arrest and/or as an adjunct device during thrombus aspiration. In some embodiments, the distal access microcatheter 530 may have a length between about 45 cm and about 150 cm, between about 45 cm and about 80 cm (e.g., about 75 cm) (e.g., for use in peripheral vasculature), between about 80 cm and about 100 cm (e.g., about 100 cm) (e.g., for use in coronary vasculature), between about 80 cm and about 150 cm (e.g., about 125 cm) (e.g., for use in neurovasculature). The distal access microcatheter 530 may have a wall thickness between about 0.00075 inches (approx. 0.02 mm) and about 0.04 inches (approx. 1 mm), which can allow for incorporating the proximal portion 200 within the walls of the distal access microcatheter 530. In some embodiments, the distal access microcatheter 530 may have an inner diameter between about 4 Fr (about 1.33 mm) and about 7 Fr (about 2.33 mm) for example, about 5 Fr (about 1.67 mm), and an outer diameter between about 5 Fr (about 1.67 mm) and about 9 Fr (about 3 mm) for example, about 6 Fr (about 2 mm).

[0778] The distal access microcatheter 530 may comprise a biomedical polymer, for example silicone, polyurethane (e.g., Polyslix, available from Duke Extrusion of Santa Cruz, Calif.), polyethylene (e.g., Rexell®, available from Huntsman) including low density polyethylene (LDPE), linear low density polyethylene (LLDPE), medium density polyethylene (MDPE), and high density polyethylene (HDPE), fluoropolymers such as fluorinated ethylene propylene, PFA, MFA, PVDF, THV, ETFE, PCTFE, ECTFE (e.g., Teflon® FEP, available from DuPont), polypropylene, polyesters including polyethylene terephthalate (PET), PBT, PETG (e.g., Hytrel®, available from DuPont), PTFE, combination polymer compounds such as thermoplastic polyurethanes and polyether block amides (e.g., Propell™, available from Foster Corporation of Putnam, Conn.), polyether block amides (e.g. Pebax®, available from Arkema of Colombes, France, Pebaslix, available from Duke Extrusion of Santa Cruz, Calif.), polyether soft blocks coupled with polyester hard blocks vinyls such as PVC, PVDC, polyimides (e.g., polyimides available from MicroLumen of Oldsmar, Fla.), polyamides (e.g., Durethan, available from Bayer, Nylon 12, available from Duke Extrusion of Santa Cruz, Calif.), polycarbonate (e.g., Corethane™, available from Corvita Corp. of Miami, Fla.), styrenics such as PS, SAN, ABS, and HIPS, acetals such as copolymers or homopolymers, high temperature performance polymers such as PEEK, PES, PPS, PSU, LCP, combinations thereof, and the like.

[0779] The distal access microcatheter 530 may comprise a hypotube (e.g., an uncut hypotube and/or a hypotube cut with a plurality of interspersed offset patterns as described herein) and/or a plurality of filaments (e.g., woven, knitted, spiraled, etc.) as reinforcement, for example in combination with a polymer inward and/or outward thereof. As described herein, certain cut patterns may inhibit pinching to such a degree that polymer may be omitted. In some embodiments, the distal access microcatheter 530 may provide an access device for proximal support and/or a thrombus aspiration device.

[0780] In some embodiments, the distal access microcatheter 530 is reinforced with the proximal portion 200, for example to inherit the maneuverability advantages of the proximal portion 200 (e.g., to facilitate proximal support and distal flexibility). In some embodiments, the distal access microcatheter 530 comprises a parameter (e.g., slot pitch) that varies from proximal to distal. For example, the pitch between slots and/or windings of a spiral may vary, from the distal end to the proximal end, as follows: about 0.005 inches (approx. 0.13 mm), about 0.01 inches (approx. 0.25 mm), about 0.02 inches (approx. 0.51 mm), about 0.04 inches (approx. 1 mm), about 0.08 inches (approx. 2 mm), and about 0.16 inches (approx. 4 mm). For another example, the pitch between slots and/or windings of a spiral may vary, from the distal end to the proximal end, as follows: about 0.005 inches (approx. 0.13 mm) for the distal-most about 20%, about 0.01 inches (approx. 0.25 mm) for the next about 15%, about 0.02 inches (approx. 0.51 mm) for the next about 15%, about 0.04 inches (approx. 1 mm) for the next about 15%, about 0.08 inches (approx. 2 mm) for the next about 15%, and about 0.16 inches (approx. 4 mm) for the next (or proximal-most) about 20%.

[0781] The distal access microcatheter 530 may comprise a radiopaque marker (e.g., a radiopaque marker band as described herein) at a distal end and/or at regular intervals (e.g., between about 0.1 mm and about 50 mm, between about 0.5 mm and about 1 mm, between about 1 mm and about 2

mm, between about 2 mm and about 3 mm, between about 3 mm and about 4 mm, between about 4 mm and about 5 mm, between about 5 mm and about 8 mm, between about 8 mm and about 10 mm, between about 10 mm and about 12 mm, between about 12 mm and about 15 mm, between about 15 mm and about 25 mm, between about 25 mm and about 35 mm, between about 35 mm and about 50 mm apart, including overlapping ranges thereof), which can help an operator of the distal access microcatheter 530 visualize the distal access microcatheter 530, which can assist in measuring clot length, vessel diameter, and/or lesion length, and/or which can serve as a surrogate marker for a measurement tool.

[0782] In some embodiments, thrombus aspiration may be performed through the microcatheter 504, the distal access microcatheter 530, and/or the guide catheter 502 depending on the extent of the clot burden. In some embodiments, thrombus aspiration may be performed through the catheter or microcatheter that is closest in proximity to the thrombus (e.g., clot) 500. In some embodiments, thrombus aspiration may be performed using flow arrest, wherein a balloon, such as part of a balloon guide catheter 502 or a balloon as part of a distal access microcatheter 530, is inflated proximal to the thrombus 500 and antegrade forward flow proximal to the thrombus 500 is temporarily stopped while thrombus aspiration is performed. In some embodiments, thrombus aspiration may be performed without any balloon inflation or temporary flow arrest.

[0783] In some embodiments, thrombus aspiration may be performed using manual negative intermittent suction (e.g., provided by a syringe) or using an automated negative suction device (e.g., provided by a vacuum pump). The suction device may be connected through suction tubing with a luer lock to the hub 590 of the microcatheter 504, the distal access microcatheter 530, and/or the guide catheter 502, or through a stop cock attached to the side port of a Y-connector 592 connected to the hub 590 of the microcatheter 504, the distal access microcatheter 530, the guide catheter 502, and/or a balloon guide catheter 502. The suction tubing may have a length that ranges from about 15 cm to about 150 cm (e.g., about 90 cm). The suction tubing may comprise a biomedical polymer, for example those described herein.

[0784] If the inner lumen of the microcatheter 504 or guide catheter 502 is substantially uniform, then the cross sectional area of the microcatheter 504 or guide catheter 502 can be considered a cylinder having a substantially uniform cross-sectional area  $k=\pi r^2$  and a volume  $V=\pi r^2 L$ . The volume of dead space within the lumen of the microcatheter 504 or the guide catheter 502 prior to starting suction may be considered to be a cylinder ( $V_0=\pi r^2 L_0$ ) with an initial suction pressure  $P_0$ . The volume of the dead space within the lumen of the microcatheter 504 or the guide catheter 502 after suction may also be considered to be a cylinder ( $V_1=\pi r^2 L_1$ ) with a suction pressure  $P_1$ . If the suction process is considered an isothermal process, then the suction pressure can be calculated using Equations 6-8:

$$P_0 V_0 = P_1 V_1 \tag{Eq. 6}$$

$$P_0 k_0 L_0 = P_1 k_1 L_1 \tag{Eq. 7}$$

$$P_0 r_0^2 L_0 = P_1 r_1^2 L_1 \tag{Eq. 8}$$

[0785] If the inner lumen of the microcatheter 504 or the guide catheter 502 is substantially uniform, then the amount of negative suction pressure is directly proportional to the length of the negative suction column within the microcath-

eter **504** or the guide catheter **502**. The change in suction pressure ( $\Delta P$ ) can be calculated using Equation 9:

$$\Delta P \propto \Delta L \quad (\text{Eq. 9})$$

**[0786]** If the inner lumen diameter or cross sectional area of a catheter is substantially uniform, then an increase in catheter length increases pressure to achieve desired suction. Higher suction pressures for thrombus aspiration in substantially uniform catheters can have clinical implications, such as: (1) higher suction pressures can result in collapse of blood vessel walls; (2) higher suction pressures can result in collapse or kinking of polymeric microcatheters or catheters; and/or (3) higher suction pressures can have safety implications on the endothelial inner wall of the blood vessels and increase the risk of vessel injury, partial or complete vessel tears, and/or vessel rupture.

**[0787]** The cross sectional area of the distal access microcatheter **530**, the microcatheter **504**, or the guide catheter **502** may not substantially uniform across the inner lumen (e.g., having a tapered configuration schematically similar to the inlet device **10300** illustrated in FIG. 17N). Referring again to FIG. 17N, in some embodiments, the microcatheter **504**, the distal access microcatheter **530**, or the guide catheter **502** may include a gradual tapering of the inner lumen diameters or cross sectional areas from proximal to distal, for example as described with respect to the tubes **10305**, **10310**, **10315**, **10320**, in which the smaller diameter tubing **10305** would be at the distal end proximate to the thrombus (e.g., clot) **500**, and the larger diameter tubing **10320** would be at the proximal end connected to the suction device. The direction of flow of blood during thrombus aspiration would be in the direction opposite to the arrows illustrated in FIG. 17N such that the thrombus **500** is aspirated from the distal end towards the proximal end of the distal access microcatheter **530**, the distal end of the microcatheter **504**, or the guide catheter **502**.

**[0788]** Still with reference to FIG. 17N, a proximal segment **10320** of the microcatheter **504**, the distal access microcatheter **530**, or the guide catheter **502** may be at an adjustable height  $h_4$ , has a pressure  $P_4$ , and has a fluid velocity  $v_4$ . Blood entering the proximal portion **200** at a distal segment **10305** of the microcatheter **504**, the distal access microcatheter **530**, or the guide catheter **502** is at a height  $h_1$ , has a pressure  $P_1$ , and has a fluid velocity  $v_1$ . As the sum of the kinetic energy per unit volume ( $\frac{1}{2}\rho_b v^2$ ), the potential energy per unit volume ( $\rho_b gh$ ), and the pressure energy ( $P$ ) remain the same, the density of the blood  $\rho_b$  and the acceleration due to gravity  $g$  ( $9.8 \text{ m/second}^2$ ) remain constant, the fluid velocity  $v_4$  entering the proximal portion **200** at the distal end of the of the microcatheter **504**, the distal access microcatheter **530**, or the guide catheter **502** can be calculated using Equation 10:

$$\frac{1}{2}\rho_b v_1^2 + \rho_b gh_1 + P_1 = \frac{1}{2}\rho_b v_4^2 + \rho_b gh_4 + P_4$$

or, rearranged,  $v_4 = \sqrt{v_1^2 + 1960(h_1 - h_4) + 2(P_1 - P_4)/\rho_b}$  (Eq. 10)

**[0789]** Since there is no fluid velocity at the distal end of the of the microcatheter **504**, the distal access microcatheter **530**, or the guide catheter **502** prior to suction being initiated ( $v_1 = 0$ ) and the height of the proximal and distal ends of the of the microcatheter **504**, the distal access microcatheter **530**, or the guide catheter **502** ( $h_1 = h_4$ ), Equation 10 may be reduced to Equation 11, or simplified by the relationship of Equation 12:

$$(P_1 - P_4) = \frac{1}{2}\rho_b v_4^2$$

$$\text{or, rearranged, } v_4 = \sqrt{2(P_1 - P_4)/\rho_b} \quad (\text{Eq. 11})$$

$$\Delta P \propto v_4^2 \quad (\text{Eq. 12})$$

**[0790]** In some embodiments, whenever the inner lumen diameter or cross sectional area is not substantially uniform (e.g., is tapered), then a change in suction pressure can result in a change in the square of the velocity of blood, which can result in desired thrombus aspiration. Limited suction pressures for thrombus aspiration in microcatheters or catheters with tapered inner lumens or cross sectional areas can have clinical implications: such as: (1) limited suction pressures can inhibit collapse of blood vessel walls; (2) limited suction pressures and/or presence of a laser cut hypotube for reinforcement can inhibit collapse or kinking of polymeric microcatheters or catheters; and/or (3) limited suction pressures may have a gentle effect on the endothelial inner wall of the blood vessels and reduce the risk of vessel injury.

**[0791]** In some embodiments, suction during thrombus aspiration through a syringe may not be substantially uniform, but can have a “crescendo suction” pattern. FIG. 271-2 is a table schematically illustrating example embodiments of crescendo suction patterns **11800**, **11805**, **11810**, **11815**, **11820** for aspiration (e.g., thrombus aspiration). Cycles of crescendo suction patterns **11800**, **11805**, **11810**, **11815**, **11820** may comprise variable intensities of negative suction in a crescendo pattern such as a small intensity negative suction pressure (S), a medium intensity negative suction pressure (M), large intensity negative suction pressure (L), and pauses or temporary stops to the negative suction pressure, which are represented by a dot or period (.) in FIG. 271-2. The crescendo suction pattern **11800** comprises a small intensity negative suction pressure (S) followed by a pause (.), which is repeated three more times (S.S.S.S.), then the pattern **11800** comprises a medium intensity negative suction pressure (M) followed by a pause (.), which is repeated three more times (M.M.M.M.), then the pattern **11800** comprises a large intensity negative suction pressure (L) followed by a pause (.), which is repeated three more times (L.L.L.L.). In some embodiments of thrombus aspiration, the crescendo suction pattern may include the following components, combinations thereof, and the like: the crescendo suction pattern **11805** (S.M.L.S.M.L.); the crescendo suction pattern **11810** (S.M.L.S.M.L.); the crescendo suction pattern **11815** (S.L.S.L.S.L.); and/or the crescendo suction pattern **11820** (S.L.M.L.S.L.M.L.). The third column graphically illustrates the patterns **11800**, **11805**, **11810**, **11815**, **11820** with the x-axis being time and the y-axis being intensity of negative suction pressure. The crescendo suction patterns **11800**, **11805**, **11810**, **11815**, **11820** may be useful in different clinical scenarios. For example, the crescendo suction pattern **11810**, which includes several pauses or temporary stops, may be useful in thrombus aspiration of hard clots, for example because the gradual increase in intensity of negative suction pressure with frequent pauses can assist agitation of the clot and/or facilitate thrombus aspiration. For another example, the crescendo suction pattern **11805**, which includes few pauses or temporary stops, may be useful in thrombus aspiration of soft clots, for example because the gradual increase in intensity of negative suction pressure with few pauses can assist with suction of the soft clot and/or facilitate thrombus aspiration.

[0792] In some embodiments, the duration of the components of a crescendo suction pattern **11800**, **11805**, **11810**, **11815**, **11820** during thrombus aspiration may vary as follows: the duration of the small intensity negative suction (S) ranges between about 1 second to about 30 seconds (e.g., about 5 seconds); the duration of the medium intensity negative suction (M) ranges between about 1 second to about 30 seconds (e.g., about 5 seconds); the duration of the large intensity negative suction (L) ranges between about 1 second to about 30 seconds (e.g., about 5 seconds); and the pauses or temporary stops ranges between the duration of the small intensity negative suction (S) ranges between about 1 second to about 15 seconds (e.g., about 5 seconds). The total duration of crescendo suction pattern including multiple repetitive cycles of patterns may range from between about 1 minute to about 15 minutes (e.g., about 5 minutes). Although some example durations are provided herein, some embodiments of the crescendo suction patterns **11800**, **11805**, **11810**, **11815**, **11820** may include durations of the patterns in accordance with the values provided above and/or durations that are about  $\pm 5\%$ , about  $\pm 10\%$ , about  $\pm 15\%$ , or about  $\pm 20\%$  of any such values and combinations thereof, and the like. The crescendo suction patterns **11800**, **11805**, **11810**, **11815**, **11820** may be considered to be uniform if the durations of each of the components of the crescendo suction pattern are substantially similar, or may be considered variable if the durations of at least one (e.g., some or all) of the components of the crescendo suction pattern are different.

[0793] In some embodiments, the intensity of the components of the crescendo suction pattern **11800**, **11805**, **11810**, **11815**, **11820** during thrombus aspiration may vary as follows: (1) the intensity of negative suction pressure for the small intensity negative suction (S) ranges between about 100 mm Hg (approx.  $13 \text{ kN/m}^2$ ) to about 350 mm Hg (approx.  $47 \text{ kN/m}^2$ ) (e.g., about 250 mm Hg (approx.  $33 \text{ kN/m}^2$ )); (2) the intensity of the medium intensity negative suction (M) ranges between about 351 mm Hg (approx.  $47 \text{ kN/m}^2$ ) to about 550 mm Hg (approx.  $73 \text{ kN/m}^2$ ) (e.g., about 500 mm Hg (approx.  $67 \text{ kN/m}^2$ )); and (3) the intensity of the large intensity negative suction (L) ranges between about 551 mm Hg (approx.  $73 \text{ kN/m}^2$ ) to about 760 mm Hg (approx. 1 atm; approx.  $101 \text{ kN/m}^2$ ) (e.g., about 750 mm Hg (approx.  $100 \text{ kN/m}^2$ )). Although some example intensities are provided herein, some embodiments of the crescendo suction patterns **11800**, **11805**, **11810**, **11815**, **11820** may include intensities of the negative suction pressures in accordance with the values provided above and/or durations that are about  $\pm 5\%$ , about  $\pm 10\%$ , about  $\pm 15\%$ , or about  $\pm 20\%$  of any such values and combinations thereof, and the like. The crescendo suction patterns **11800**, **11805**, **11810**, **11815**, **11820** may be considered to be uniform if the intensities of the negative suction pressure of each of the components of the crescendo suction pattern are substantially similar, or may be considered variable if the intensities of at least one (e.g., some or all) of the components of the crescendo suction pattern are different.

[0794] In some embodiments, the suction tubing is connected to a disposable canister and a peristaltic motor pump. In some embodiments, the peristaltic motor pump is controlled by power electronics to generate the crescendo suction patterns **11800**, **11805**, **11810**, **11815**, **11820** with a desired intensity and/or duration of negative suction pressure. The power electronics may comprise an customized integrated circuit board or an integrated chip, and the crescendo suction patterns **11800**, **11805**, **11810**, **11815**, **11820** can be stored in

the power electronics. The peristaltic motor pump includes a switch or external control panel for the operator configured to allow the operator to choose from any of the crescendo suction patterns **11800**, **11805**, **11810**, **11815**, **11820** during a thrombus aspiration procedure.

[0795] In some embodiments, as the distal portion **100** expands radially outwardly, parts of the vessel wall may slightly expand, the amount of expansion depending on, e.g., braid parameters, filament material, filament size, etc. Vessel expansion can create a channel to the sides of the thrombus (e.g., clot) **500** to at least partially restore blood flow even before removal of the thrombus **500**. As described above, about 1,900,000 brain cells die every minute without blood supply, so the brain cells kept alive by this restoration could be significant. To the extent that current thrombectomy devices may also create a channel upon expansion, such channel may only be along a portion of the thrombus **500** such that the tissue distal thereto is still devoid of blood flow. Some current thrombectomy (e.g., laser-cut) devices may also cause stress to vessel sidewalls because they are not size-sensitive, so such vessel expansion could even lead to rupturing and/or causing distal debris. By contrast, some embodiments of the distal portions **100** described herein can create a channel that is proportional to size of vessel, which is gentler and safer than size-blind expansion, and a distal bulb can trap distal debris.

[0796] In some embodiments, after unsheathing part of the distal portion **100** (e.g., enough so that a bulb is proximal to the proximal end of the thrombus **500**), the device **10**, **20**, **30**, **40** may optionally be torsionally rasped in a rotational direction. Part of the proximal portion **200** outside the subject is rotated by the user. The distal portion **100**, coupled to the proximal portion **200**, also rotates. In some embodiments, part of the distal portion **100** apposes the sidewalls of the vessel and resists rotation. The rotational forces are generally exerted from proximal to distal along the length of the distal portion **100**, so the distal-most part apposing the sidewalls of the vessel are most likely to rotate last. In some embodiments, a distal-most bulb of the distal portion **100** apposes the sidewalls of the vessel distal to the thrombus **500**. In certain such embodiments, the distal-most bulb of the distal portion **100** substantially maintains a rotational position until expanded parts of the distal portion **100** proximal to the distal-most bulb are at least partially rotated. Rotation of the distal portion **100** entraps the clot and collects any debris. The distal portion **100** can rotationally scrape the sidewalls of the vessel to remove portions of the clot attached to the endothelium wall, which can remove more than free-floating debris. The non-laser cut braided nature of the bulbs can facilitate gentle entrapment of the clot without perforating the vessel.

[0797] As used herein, torsional rasping shall be given its ordinary meaning and shall include wringing and twisting. An incomplete analogy for torsional rasping is wringing out a towel, where a person grabs one end of the towel with one hand and the opposite end of the towel with the other hand, and, while holding the first end still, rotates the second end. The towel twists, generally shrinking in diameter, until physical forces inhibit further rotation. Rather than ends of a towel, ends of the distal portion **100** are grasped, the distal end by apposing sidewalls and the proximal end by the proximal portion. FIG. 27J is a schematic diagram of a distal portion **100** of a vascular treatment device being torsionally rasped. In FIG. 27J, the initial rotation of the proximal-most expanded bulbs of the distal portion **100** are shown. The analogy is incomplete because the towel does not inform clot entrap-

ment. As described herein, the braided nature of the distal portion **100** can trap the clot between undulations between the bulbs and/or undulations of the woven wires. FIG. 27K is a schematic diagram of a distal portion **100** of a vascular treatment device being torsionally rasped. The expanded bulbs of the distal portion are shown wrapped around a thrombus (e.g., clot) **500**.

[0798] The tension may be applied throughout the torsional rasping by continually rotating the proximal portion **200** or at least not allowing the proximal portion **200** to rotate in the opposite direction. Referring again to the towel analogy, releasing the tension may allow the distal portion **100** to at least partially unfurl, which may, for example, allow trapped clot and/or emboli to escape, although such escaped thrombi may be captured by other parts of the distal portion **100**.

[0799] In some embodiments, one of the bulbs (e.g., a distal-most bulb of the distal portion **100** apposing the sidewalls of the vessel) can act as an embolic filter during a clot retrieval procedure (e.g., trapping emboli, such as emboli created during expansion of the distal portion **100** and/or torsional rasping of the distal portion **100**) such that no other, separate, or additional embolic filter is used. The thrombectomy procedures described herein are different than embolic filters. For example, the devices **10**, **20**, **30**, **40** can actively retrieve a clot, for example according to the procedures described herein, rather than passively collecting emboli.

[0800] In some procedures, the devices **10**, **20**, **30**, **40** described herein may be used as an embolic filter in combination with another type of catheter-based or wire-based system (e.g., during performance of another vascular procedure such as angioplasty, atherectomy, aspiration, stenting, embolic coil insertion, intra-arterial thrombolysis, bypass, etc.), or even an additional thrombectomy device (e.g., a device **10** and a device **20**). For example, a distal-most bulb of a distal portion **100** may be deployed distal to the site of the procedure. In some embodiments, additional parts of the distal portion **100** may be deployed during and/or after performance of a procedure. In certain such embodiments, the distal portion **100** may be torsionally rasped (e.g., to rotationally scrape sidewalls of a vessel after plaque may have been loosened by angioplasty or atherectomy, to rotationally scrape the inside of a stent, to capture debris proximal to the distal-most bulb of the distal portion **100**, etc.). In certain such embodiments, the microcatheter **504** may be advanced slightly more distally to allow the other system to also be at least partially distal to the clot. The lumen of the proximal portion **200** and optionally the distal portion **100** may be used as a working channel for other devices.

[0801] The rotational direction may be clockwise or counterclockwise. For example, the handedness (left handed or right handed) of the user may make a particular rotational direction more comfortable (e.g., turning the proximal portion **200** towards the user's body). In some embodiments, a direction of rotation may be based at least partially on the design of the proximal portion **200**. For example, referring again to FIGS. 16A and 16B, if the proximal portion **200** includes slits with a positive angle **250**, then counterclockwise rotation may better transfer rotational forces and if the proximal portion **200** includes slits with a negative angle **250**, then clockwise rotation may better transfer rotational forces.

[0802] In some embodiments, the rotation of the distal portion **100** is less than the rotation of the proximal portion **200**. For example, in some embodiments, a 360° rotation of the proximal portion **200** results in less than 360° rotation of the

distal portion **100** (e.g., rotation of the distal portion between about 90° and about 359°, between about 90° and about 270°, between about 90° and about 180°, etc.). In some embodiments, a ratio of rotational forces at the proximal portion **100** and the distal portion **200** are not 1:1. For example, the ratio may be less than 1:1 (e.g., 1:0.75, 1:0.5, or 1:0.25, etc.). In some embodiments, a non-1:1 ratio may provide a gentle rotation that can reduce the risk that the blood vessel is rotated, displaced, disrupted, or perforated. Resistance of a distal-most bulb or other bulbs of the distal portion **100** apposing the sidewalls of the vessel may contribute to reduced rotation of the distal portion **100**.

[0803] In some embodiments, a wire torque device, handle, or the like may be used to assist rotation of the proximal portion **200**. In some embodiments, the proximal portion is rotated between about 90° and about 3,000°, between about 360° and about 2,500°, or between about 720° and about 1,440°. In some embodiments, the proximal portion is rotated at least three full rotations (e.g., greater than about 1,080°). In some embodiments, the proximal portion is rotated at least six full rotations (e.g., greater than about 2,160°). The upper limit of the amount of rotation may vary by device and by clot. In some embodiments, physical forces may inhibit further rotation (e.g., the wires of the distal portion **100** and/or the clot can no longer be radially compressed). In some embodiments, the diameter of the distal portion **100** may reduce enough that further rotation rotates the distal portion **100** does not effect further torsional rasping.

[0804] In some embodiments in which torsional rasping is performed on soft clots, the distal portion **100** of the device **10**, **20**, **30**, **40** comprises bulbs configured to expand from the collapsed state to the expanded state substantially instantaneously (e.g., comprising super-elastic material), and the clot may be entwined around the bulbs in the hills and valleys.

[0805] In some embodiments in which torsional rasping is performed on hard clots, the distal portion **100** of the device **10**, **20**, **30**, **40** comprises bulbs configured to expand from the collapsed state to the expanded state with a time-delayed expansion (e.g., comprising shape-memory material), the torsional rasping may be performed while the distal portion **100** is in a secondary shape such as a twisted or spiral shape (e.g., occurring due to contact with blood at body temperature and/or warm saline), and the clot may be entwined by that secondary shape.

[0806] FIG. 27L is a schematic diagram illustrating an example embodiment of a two-way shape memory effect of a distal portion **100** of a vascular treatment device, for example the distal portion **100** of device **10**, **20**, **30**, or **40**. When the distal portion **100** is at a first temperature such as ambient room temperature (e.g., about 25° C.), the distal portion **100** is in the collapsed configuration as illustrated in FIG. 27F. When the distal portion **100** is at a second temperature (e.g., about 37° C.), which can be achieved on contact with blood at body temperature, the distal portion **100** further expands to the expanded configuration as illustrated in FIGS. 27G and 27H, depending on the length of retraction of the microcatheter **504**. When the distal portion **100** is at a third temperature (e.g., about 18° C.), which can be achieved by injecting cold saline through the microcatheter **504**, a distal access microcatheter **530**, or the guide catheter **502**, the distal portion **100** foreshortens to grasp the thrombus (e.g., clot) **500** better in a twisted spiral configuration as illustrated in FIGS. 27K and 27L. In some embodiments, this twisting grabbing can occur without rotation of the proximal portion **200**.

[0807] If the thrombus (e.g., clot) **500** is not adequately grasped, for example as evidenced during angiography, after stopping the injection of cold saline through the microcatheter **504**, a distal access microcatheter **530**, or the guide catheter **502**, the distal portion **100** returns back to the second temperature (e.g., about 37° C.) on continued contact with blood at body temperature, and the distal portion **100** expands once again to the expanded configuration as illustrated in FIGS. 27G and 27H. When the distal portion **100** is once again exposed to a third temperature (e.g., about 37° C.), which can again be achieved by injecting cold saline through the microcatheter **504**, a distal access microcatheter **530**, or the guide catheter **502**, the distal portion **100** foreshortens again to grasp the thrombus **500** in a twisted spiral configuration as illustrated in FIGS. 27K and 27L. In some embodiments, this twisting grabbing can occur without rotation of the proximal portion **200**. In some embodiments, the second twisting may better capture the thrombus **500** than the first twisting.

[0808] FIG. 27M is a schematic diagram illustrating the retraction of a distal portion **100** of a vascular treatment device and a thrombus **500**. In some embodiments, the device **10**, **20**, **30**, **40** may be proximally retracted (e.g., after torsional rasping or without torsional rasping), for example by retracting (e.g., substantially simultaneously and/or at a similar rate) the proximal portion **200** and the microcatheter **504** until both the proximal portion **200** and the microcatheter **504** are through the guide catheter and out of the body of the subject being treated. During this retraction, the parts of the distal portion **100** that were expanded remain expanded and the parts of the distal portion **100** that were not expanded remain in the contracted state. The proximal portion **200** and the microcatheter **504** may continue to be retracted until the distal portion **100** and the clot are out of the guide catheter.

[0809] Negative suction pressure may be applied (e.g., using a crescendo suction pattern (e.g., as described with respect to FIG. 27I-2)) through the guide catheter **502** during proximal retraction. If no blood comes out after stopping aspirating, then the user may know that something, such as the clot, is blocking the guide catheter **502**. A user may perform thrombus aspiration until that blockage comes out, as described herein. When blood comes out, the user may, for example flush with fluid (e.g., heparinized saline), perform post-thrombectomy angiogram, etc.

[0810] In some embodiments, the removed thrombus (e.g., clot) **500** may be placed next to a ruler **520** on a package containing the device **10**, **20**, **30**, **40** or another ruler. The user may compare the measured length of the removed thrombus (e.g., clot) **501** to the estimated (e.g., before the procedure) and/or known (e.g., measured during the procedure using radiopaque crossings) length. FIG. 27N illustrates an example embodiment of a comparison of a thrombus **501** length to a ruler **520**. The thrombus **501** measures about 2 inches (approx. 5.1 cm). If the length of the removed thrombus **501** is substantially less than the estimated and/or known length, the user may deduce that the entire thrombus **500** was not removed. The user may check the aspiration syringe or other equipment for any additional lengths of clot. Knowledge that some of the thrombus **500** may have not been removed allows the user to figure out a further treatment strategy. As described above, such comparison and removal validation is generally not possible with devices that remove a portion of the thrombus **500** at a time (e.g., due to a fixed and limited working length).

[0811] FIG. 27O is a schematic diagram of a distal portion **100** of a thrombectomy device acting as a filter device. In some embodiments, upon expansion, the distal-most bulb or bulbs can appose the sidewalls of the vessel distal to the thrombus (e.g., clot) **500**, and the distal-most bulb(s) can act as a distal filter or entrapment mechanism that can catch or collect pieces of thrombus (e.g., emboli) **500** that may become separated during thrombectomy, an angioplasty, aspiration, stenting, or other vascular procedures.

[0812] FIG. 27P is a schematic diagram illustrating an example embodiment of a two-way shape memory effect of the proximal portion **9700** of a thrombectomy device, for example the proximal portion **200** of device **10**, **20**, **30**, or **40**. When the proximal portion **9700** is at a first temperature such as ambient room temperature (e.g., about 25° C.), the proximal portion **9700** is in a substantially linear configuration. When the proximal portion **9700** is at a second temperature (e.g., about 37° C.), which can be achieved on contact with blood at body temperature, some or all the proximal portion **9700** takes shape such as a gentle S-shape, which can mimic curves of the vessel anatomy, which can alleviate stress on the vessels. When the proximal portion **9700** is removed from the body after a vascular procedure, for example a thrombectomy procedure, the parts of or all of the proximal portion **9700** may retain the shape.

[0813] If the thrombus (e.g., clot) **500** is not adequately removed after a first thrombectomy attempt, for example as evidenced during angiography, reintroduction of the proximal portion **9700** through the hub **590** of the microcatheter **504** may be difficult. The proximal portion **9700** may be exposed to a third temperature (e.g., about 18° C.) (e.g., by placement in a sterile bowl containing cold saline). Upon reaching the third temperature, the proximal portion **9700** returns to the substantially linear configuration. This two-way shape memory effect of the proximal portion **9700** may be useful, for example, in vascular procedures that may utilize multiple attempts.

[0814] In some embodiments, a proximal portion **200** having super-elasticity and that has a substantially linear configuration shape set will attempt to return to that substantially linear configuration as the proximal portion bends in a tortuous blood vessel, which can straighten the tortuous blood vessel, which may lead to rupture of any perforator vessels arising from the tortuous blood vessel. In some embodiments, a proximal portion **200** having a two-way shape memory effect may be gentler on blood vessels than a proximal portion **200** having super-elasticity.

[0815] Once the microcatheter **504**, and, if used, a distal access microcatheter **530**, and the device **10**, **20**, **30**, **40** are out of the subject and no further treatment is to be performed, the guide catheter **502** may be removed and the subject sealed (e.g., stitching the entry point or using a bandage or dressing such as a Tegaderm®, available from 3M). The methods described above need not all be performed or performed in the order recited. Other steps can also be performed. For example, steps such as vessel access, drug treatment, and the like are generally omitted for clarity.

[0816] In some embodiments, the devices **10**, **20**, **30**, **40** described herein can be used in the brain. In some embodiments, vasculature in the periphery can be treated using the devices **10**, **20**, **30**, **40** described herein. In some embodiments, coronary vessels may be treated the devices **10**, **20**, **30**,



40 described herein. In some embodiments, the abdominal aorta and branches may be treated using the devices 10, 20, 30, 40 described herein.

[0817] FIG. 28A is a schematic diagram of a guide catheter 502 proximal to an aneurysm 503 in vasculature. The aneurysm 503 illustrated in FIG. 28A is in the right middle cerebral artery, although other aneurysms 503 may also be treated, including sidewall aneurysms and bifurcation aneurysms. The guide catheter 502 is in the right internal carotid artery, for example having been routed to that position as described above. The aneurysm 503 may have been noted during CT scan angiography or MRI angiography or angiography with the guide catheter 502 or another catheter (e.g., a shuttle or a balloon guide catheter), for example in the right internal carotid artery. A catheter angiogram may be performed using the guide catheter 502 after positioning the guide catheter 502.

[0818] FIGS. 28B and 28C are schematic diagrams of a microwire 506 distal to an aneurysm 503 in vasculature and a microcatheter 504 over the microwire 506. In some embodiments, referring again to FIG. 27I-1, a distal access microcatheter 530 with a microcatheter 504 inserted inside the distal access microcatheter 530 may be through the guide catheter 502, which is positioned in the right internal carotid artery proximal to the aneurysm 503, and over a steerable microwire 506. A steerable microwire 506 (e.g., having an outer diameter of about 0.014 inches (approx. 0.36 mm) is inserted into the microcatheter 504, extending some distance (e.g., about 2 cm to about 4 cm) out of the distal end of the microcatheter 504. In some embodiments, a distal access microcatheter 530 is not used and the microcatheter 504 is advanced over the microwire 506. The microwire 506 can be advanced and steered for some distance into the petrous and cavernous segments of the right internal carotid artery, followed by advancement of the microcatheter 504 over the microwire 506. The microwire 506 and the microcatheter 504 can be sequentially advanced into the supraclinoid segment of the right internal carotid artery and then into the right middle cerebral artery until the desired point in the vasculature distal to the aneurysm 503 or lesion, for example by about 0.5 mm to about 5 mm (e.g., into the superior M2 segment or inferior M2 segment of the middle cerebral artery). Other locations of aneurysms 503 include, but are not limited to, the supraclinoid segment of the right internal carotid artery and the anterior communicating artery at the junction of the right A1 segment and A2 segments of the anterior cerebral arteries.

[0819] FIG. 28D is a schematic diagram of a microcatheter 504 distal to an aneurysm 503 in vasculature. The microwire 506 has been removed from the microcatheter 504, leaving the microcatheter 504 distal to the aneurysm 503. The distal end of the microcatheter 504 may range from about 5 mm to 45 mm (e.g., about 15 mm) distal to the aneurysm 503 or a lesion (e.g., in the superior segment of the right middle cerebral artery or the inferior segment of the right middle cerebral artery). In some embodiments in which a distal access microcatheter 530 is used, the distal end of the distal access microcatheter 530 may range from about 5 mm to 50 mm (e.g., about 25 mm) proximal to the aneurysm 503 or a lesion in the vasculature (e.g., in the proximal middle cerebral artery, the supraclinoid right internal carotid artery, or the cavernous segment of the right internal carotid artery for an aneurysm 503 in the right middle cerebral artery).

[0820] Referring again to FIG. 27E, the distal portion 100 of vascular treatment device (e.g., flow diverter) can be intro-

duced into the hub 590 of the microcatheter 504 through an introducer sheath 540 with the distal portion 100 in the constrained state. The proximal portion 200 of the vascular treatment device is pushed to advance the device through the microcatheter 504. The device is advanced until the distal end of the distal portion 100 is proximate to the distal end of the microcatheter 504, which is distal to the distal end of the aneurysm 503. The microcatheter 504 is then retracted (e.g., unsheathed, unsheathed) while holding the proximal portion 200 still so that the longitudinal position of the device is maintained.

[0821] FIG. 28E is a schematic diagram of an example embodiment of the distal portion 100 of a vascular treatment device being deployed distal to an aneurysm 503 in vasculature. The retraction of the microcatheter 504 exposes the distal portion 100, from the distal end back, which can allow the exposed sections of the distal portion 100 to self-expand. For example, the distal portion 100 may include a wide-mouth distal neck and/or a distal-most bulb 9850 that can expand to appose the sidewalls of the vasculature distal to the aneurysm 503.

[0822] In some embodiments, exposed sections of the distal portion 100 can self-expand because the distal portion 100 includes at least some super-elastic filaments configured to self-expand, for example, due to stress-induced martensite (SIM) without any particular change in temperature. Super-elastic materials can expand substantially instantaneously from a collapsed configuration to an expanded configuration when the unsheathed. In some embodiments, exposed sections of the distal portion 100 can self-expand because the distal portion 100 includes at least some shape memory filaments that configured to self-expand, for example, due to temperature-activated austenitic transformation (e.g., upon a change in temperature such as greater than room temperature (about 25° C.) (e.g., to about body temperature (approx. 37° C.), less than room temperature (e.g., to about 18° C.), etc.). Shape-memory materials can expand slowly from a collapsed configuration to an expanded configuration when unsheathed upon contact with warm fluid (e.g., blood at body temperature, warm saline) and/or cold fluid (e.g., cold saline).

[0823] In some embodiments, the shape memory effect of the shape memory filaments can be one-way (e.g., a stress-induced change in shape returns to a baseline shape upon heating, with no change upon cooling). With the one-way shape memory effect, the material remembers one shape above a certain temperature. In some embodiments, the shape memory effect of the shape memory filaments can be two-way (e.g., a stress-induced change in shape returns close to baseline shape upon heating, and a second shape can be achieved upon cooling). With the two-way shape memory effect, the material remembers a first shape above a first temperature and a second shape below a second temperature.

[0824] FIG. 28F is a schematic diagram of an example embodiment of the distal portion 100 of a vascular treatment device being deployed across an aneurysm 503 in vasculature. In contrast to a tubular device, for example, the deployment of a distal portion 100 comprising bulbs and wide-mouthed necks 9850 across the mouth of an aneurysm can allow for better wall apposition and/or reduce the risk of an endo-leak.

[0825] FIG. 28G is a schematic diagram of an example embodiment of the distal portion 9600 of FIG. 6G deployed across an aneurysm 9645 in vasculature. Referring again to FIG. 6G, the distal portion 9600 may be useful, for example,

in aneurysms **9645** proximal to a vessel bifurcation, for example, for deployment of the high pore size distal bulb **9603** in the proximal M1 segment of the middle cerebral artery **9640** and the high pore size middle bulb **9605** at the internal carotid artery bifurcation near the origin of the middle cerebral artery **9640** and the anterior cerebral artery **9630**, which can allow blood flow into the arteries **9630**, **9640** and their perforators distal to the aneurysm **9645**, which can inhibit or prevent occlusion of blood flow to the arteries **9630**, **9640**, which could otherwise lead to life-threatening stroke. In some embodiments, deployment of the small pore size proximal segment **9604** across an aneurysm **9645** located in the supraclinoid internal carotid artery **9635**, in the illustrated example not involving the internal carotid artery bifurcation, can aid in thrombosis of the aneurysm **9645**. The bulbs **9603**, **9605**, **9607**, the wide-mouthed necks in between the bulbs **9614** and **9616**, the wide mouthed proximal neck **9618**, and the distal neck **9612** can allow provide good wall apposition including the site of vessel bifurcation, which can inhibit or prevent the risk of an endo-leak into the aneurysm **9645**. In some embodiments, the force/resistance (e.g., radial force) of the bulbs and/or necks is in a range sufficient to slightly expand the target vessel(s) in the range of about 0% to about 30%, and the shapes of the bulbs and necks are at least partially preserved. In some embodiments, the radial force of the bulbs and/or necks is in a range sufficient to appose the sidewalls of the vessel to inhibit or prevent an endo-leak, but not sufficient to expand the vessel, and the shapes of the bulbs and necks are no longer preserved such that the shape of the distal portion **9600** is substantially tubular, whether tapered or non-tapered, for example based on the shape of the target vessel.

[0826] FIG. 28H is a schematic diagram of an example embodiment of the distal portion **11100** of FIG. 7B deployed across an aneurysm **11150** in vasculature. The distal portion **11100** may be useful, for example, for deployment in fusiform aneurysms at a vessel bifurcation such as an abdominal aortic aneurysm (AAA) **11150** illustrated in FIG. 28H. In some embodiments, a procedure may be performed percutaneously and entirely through one arterial access, for example the left common femoral artery and the left common iliac artery **11140**. For example, deployment of the large pore sized proximal lateral neck **11120** in the left common iliac artery **11140** and the large pore sized proximal medial neck **11125** in the right common iliac artery **11160** can allow blood flow into these arteries, which can inhibit or prevent occlusion of these arteries, which could otherwise lead to renal failure or life-threatening limb ischemia. In some embodiments, deployment of the large pore sized distal neck **11130** in the supra-renal or infra-renal abdominal aorta can allow blood flow into the renal arteries **11145** and their branches, which can inhibit or prevent occlusion of blood flow to the renal arteries **11145**, which could otherwise lead to kidney failure. In some embodiments, deployment of the small pore sized spherical proximal bulb **11105**, the elongate distal bulb **11110**, and the neck **11115** between the bulbs **11105**, **11110** across the abdominal aortic aneurysm **11150** in the infra-renal abdominal aorta can aid in thrombosis of the aneurysm **11150**. The large pore sized proximal lateral neck **11120** may be deployed in the left common iliac artery **11140**. Given the relatively short length and large pore size of the proximal medial neck **11125**, the neck **11125** can be deployed into the origin of the right common iliac artery **11160** while the proximal lateral neck **11120** is deployed in the left common iliac

artery **11140**, which can allow blood flow into these arteries, which can inhibit or prevent occlusion of blood flow to these arteries, which could otherwise lead to renal failure or life-threatening limb ischemia. In some embodiments, the force/resistance (e.g., radial force) of the bulbs and/or necks is in a range sufficient to slightly expand the target vessel(s) in the range of about 0% to about 30%, and the shapes of the bulbs and necks are at least partially preserved. In some embodiments, the radial force of the bulbs and/or necks is in a range sufficient to appose the sidewalls of the vessel to inhibit or prevent an endo-leak, but not sufficient to expand the vessel, and the shapes of the bulbs and necks are no longer preserved such that the shape of the distal portion **11100** is substantially tubular, whether tapered or non-tapered, for example based on the shape of the target vessel.

[0827] FIG. 28I is a schematic diagram of an example embodiment of the distal portion **9000** FIG. 6A deployed across an aneurysm **9050** in vasculature. The distal portion **9000** may be useful, for example, for deployment of the small pore size middle segment **9002** across a wide-mouthed posterior-communicating artery brain arterial aneurysm **9050**, which is located in the supraclinoid segment of the internal carotid artery **9030**, which can aid in thrombosis of the aneurysm **9050**. Deployment of the high pore size proximal segment **9006** and the high pore size distal segment **9004** on either side of the aneurysm **9050** can allow blood flow into arteries proximal and distal to the aneurysm **9050**, for example to the proximal ophthalmic artery **9040** and the distal anterior choroidal artery **9045** and superior hypophyseal artery distally **9035**, which can inhibit or prevent occlusion of the arteries **9035**, **9040**, **9045** and/or resulting dysfunction (e.g., occlusion of the ophthalmic artery **9040** can cause blindness, occlusion of the anterior choroidal artery **9045** can cause paralysis of the arms and legs). The bulbs and wide-mouthed necks of the distal portion **9000** can provide good wall apposition, including at the site of vessel bifurcation, which can inhibit or prevent the risk of an endo-leak into the aneurysm **9050**. In some embodiments, the force/resistance (e.g., radial force) of the bulbs and/or necks is in a range sufficient to slightly expand the target vessel(s) in the range of about 0% to about 30%, and the shapes of the bulbs and necks are at least partially preserved. In some embodiments, the radial force of the bulbs and/or necks is in a range sufficient to appose the sidewalls of the vessel to inhibit or prevent an endo-leak, but not sufficient to expand the vessel, and the shapes of the bulbs and necks are no longer preserved such that the shape of the distal portion **9000** is substantially tubular, whether tapered or non-tapered, for example based on the shape of the target vessel.

[0828] FIG. 28J is a schematic diagram of an example embodiment of the distal portion **9100** of FIG. 6B deployed across an aneurysm **9135** in vasculature. The distal portion **9100** may be useful, for example, for deployment of the small pore size distal segment **9110** across a proximal middle cerebral artery M2 segment brain arterial aneurysm **9135**, which is located near the distal M1 segment of the middle cerebral artery **9130**, which can aid in the thrombosis of the aneurysm **9135**. Deployment of the high pore size proximal segment **9120** across the distal M1 segment of the middle cerebral artery **9130** can allow blood flow into the perforators arising from the distal M1 segment of the middle cerebral artery **9130**, for example the proximal lateral lenticulo-striate perforating arteries **9140**, **9145**, which can inhibit or prevent occlusion of such perforators **9140**, **9145** and/or resulting

dysfunction (e.g., occlusion of the lenticulo-striate perforators **9140**, **9145** can cause paralysis of the arms and legs). The bulbs and wide-mouthed necks of the distal portion **9100** can provide good wall apposition, including at the site of vessel bifurcation, which can inhibit or prevent the risk of an endo-leak into the aneurysm **9135**. In some embodiments, the force/resistance (e.g., radial force) of the bulbs and/or necks is in a range sufficient to slightly expand the target vessel(s) in the range of about 0% to about 30%, and the shapes of the bulbs and necks are at least partially preserved. In some embodiments, the radial force of the bulbs and/or necks is in a range sufficient to appose the sidewalls of the vessel to inhibit or prevent an endo-leak, but not sufficient to expand the vessel, and the shapes of the bulbs and necks are no longer preserved such that the shape of the distal portion **9100** is substantially tubular, whether tapered or non-tapered, for example based on the shape of the target vessel.

[**0829**] FIG. **28K** is a schematic diagram of an example embodiment of the distal portion **9200** of FIG. **6C** deployed across an aneurysm **9240** in vasculature. The distal portion **9200** may be useful, for example, for the deployment of the high pore size distal segment **9210** in internal carotid artery **9230** distal to the cavernous aneurysm **9240**, which can allow blood flow into the distal artery **9235**, for example the ophthalmic artery, which can inhibit or prevent occlusion of the artery **9235** and/or resulting dysfunction (e.g., occlusion of the ophthalmic artery **9235** can cause blindness). Deployment of the small pore size proximal segment **9220** across a brain aneurysm **9240** located in the distal cavernous segment of the internal carotid artery **9230** can aid in the thrombosis of the aneurysm **9240**. The bulbs and wide-mouthed necks of the distal portion **9200** can provide good wall apposition, including at the site of vessel bifurcation, which can inhibit or prevent the risk of an endo-leak into the aneurysm **9240**. In some embodiments, the force/resistance (e.g., radial force) of the bulbs and/or necks is in a range sufficient to slightly expand the target vessel(s) in the range of about 0% to about 30%, and the shapes of the bulbs and necks are at least partially preserved. In some embodiments, the radial force of the bulbs and/or necks is in a range sufficient to appose the sidewalls of the vessel to inhibit or prevent an endo-leak, but not sufficient to expand the vessel, and the shapes of the bulbs and necks are no longer preserved such that the shape of the distal portion **9200** is substantially tubular, whether tapered or non-tapered, for example based on the shape of the target vessel.

[**0830**] FIG. **28L** is a schematic diagram of an example embodiment of the distal portion **9300** of FIG. **6D** deployed across aneurysms **9335**, **9340** in vasculature. The distal portion **9300** may be useful, for example, when two aneurysms **9335**, **9340** along a vessel **9330** are separated by a segment including a branch vessel **9350**. For example, deployment of the small pore size distal segment **9304** across a posterior communicating artery (P-comm) brain aneurysm **9335** in the supraclinoid segment of the internal carotid artery **9330** and deployment of the small pore size proximal segment **9306** across a distal cavernous internal carotid artery aneurysm **9340** in the internal carotid artery **9330** can aid in the thrombosis of the aneurysms **9335**, **9340**, and deployment of the high pore size middle segment **9320** between the P-comm aneurysm **9335** and the distal cavernous internal carotid artery aneurysm **9340** can allow blood flow into the ophthalmic artery **9350**, which can inhibit or prevent occlusion of the ophthalmic artery **9350**, which could otherwise cause

blindness. The bulbs and wide-mouthed necks of the distal portion **9200** can provide good wall apposition, including at the site of vessel bifurcation, which can inhibit or prevent the risk of an endo-leak into the aneurysms **9335**, **9340**. In some embodiments, the force/resistance (e.g., radial force) of the bulbs and/or necks is in a range sufficient to slightly expand the target vessel(s) in the range of about 0% to about 30%, and the shapes of the bulbs and necks are at least partially preserved. In some embodiments, the radial force of the bulbs and/or necks is in a range sufficient to appose the sidewalls of the vessel to inhibit or prevent an endo-leak, but not sufficient to expand the vessel, and the shapes of the bulbs and necks are no longer preserved such that the shape of the distal portion **9300** is substantially tubular, whether tapered or non-tapered, for example based on the shape of the target vessel.

[**0831**] FIG. **28M** is a schematic diagram of an example embodiment of the distal portion **9400** of FIG. **6E** deployed across an aneurysm **9435** in vasculature. The distal portion **9400** may be useful, for example, when an aneurysm **9435** is between several arteries and/or perforators. For example, deployment of the small pore size middle segment **9430** across a dissecting pseudo-aneurysm **9435** in the V4 segment of the vertebral artery **9445** can aid in thrombosis of the aneurysm **9435**, and deployment of the high pore size proximal segment **9404** and the high pore size distal segment **9402** across the arteries proximal and distal to the aneurysm **9435** can allow blood flow into these arteries, for example the proximal posterior inferior cerebellar artery (PICA) **9470** and the distal basilar artery **9440** and its perforators **9460**, **9465**, which can inhibit or prevent occlusion of these arteries and/or resulting dysfunction (e.g., occlusion of the PICA **9470** can cause balance problems while walking, occlusion of the basilar artery **9440** or its perforators can cause life threatening strokes, etc.). The medium braid angle segments **9406**, **9408** have medium pore sizes, which can allow for variability and error while deploying the distal portion **9400**, which can inhibit or prevent occlusion of these arteries or their perforators. The contralateral V4 segment of the vertebral artery **9450** can supply the contralateral PICA **9455** and the basilar artery **9440** through the woven neck and bulb of the high pore size distal segment **9402**. The bulbs and wide-mouthed necks of the distal portion **9400** can provide good wall apposition, including at the site of vessel bifurcation, which can inhibit or prevent the risk of an endo-leak into the aneurysm **9435**. In some embodiments, the force/resistance (e.g., radial force) of the bulbs and/or necks is in a range sufficient to slightly expand the target vessel(s) in the range of about 0% to about 30%, and the shapes of the bulbs and necks are at least partially preserved. In some embodiments, the radial force of the bulbs and/or necks is in a range sufficient to appose the sidewalls of the vessel to inhibit or prevent an endo-leak, but not sufficient to expand the vessel, and the shapes of the bulbs and necks are no longer preserved such that the shape of the distal portion **9400** is substantially tubular, whether tapered or non-tapered, for example based on the shape of the target vessel.

[**0832**] FIG. **28N** is a schematic diagram of an example embodiment of the distal portion **9500** of FIG. **6F** deployed across an aneurysm **9540**, **9550** in vasculature. The distal portion **9500** may be useful, for example, for deployment of the small pore size middle segment **9504** across a fusiform aortic aneurysm **9540**, **9550** located in the infra-renal abdominal aorta **9530**, and not involving the aorto-iliac bifurcation, which can aid in thrombosis of the aneurysm **9540**,

**9950.** Deployment of the high pore size proximal segment **9506** and the high pore size distal segment **9502** across arteries proximal and distal to the aneurysm **9540, 9550** can allow blood flow into these arteries, for example the distal bilateral renal arteries **9535, 9545** and the proximal intercostal and lumbar arteries, which can inhibit or prevent occlusion and/or resulting dysfunction (e.g., lack of blood flow to the kidneys can lead to renal failure, occlusion of the intercostal and lumbar arteries could lead to bowel and bladder dysfunction, etc.). The bulbs **9503, 9505, 9507**, the wide-mouthed neck **9514** between the bulbs **9503, 9505**, the wide-mouthed neck **9516** between the bulbs **9505, 9507**, the wide-mouthed proximal neck **9518**, and the wide-mouth distal neck **9512** of the distal portion **9500** can provide good wall apposition, which can inhibit or prevent the risk of an endo-leak into the aneurysm **9540, 9550**. In some embodiments, the force/resistance (e.g., radial force) of the bulbs and/or necks is in a range sufficient to slightly expand the target vessel(s) in the range of about 0% to about 30%, and the shapes of the bulbs and necks are at least partially preserved. In some embodiments, the radial force of the bulbs and/or necks is in a range sufficient to appose the sidewalls of the vessel to inhibit or prevent an endo-leak, but not sufficient to expand the vessel, and the shapes of the bulbs and necks are no longer preserved such that the shape of the distal portion **9500** is substantially tubular, whether tapered or non-tapered, for example based on the shape of the target vessel.

**[0833]** FIG. 28O is a schematic diagram of an example embodiment of the distal portion **11000** of FIG. 7A deployed across a bifurcation aneurysm **11005** in vasculature. The distal portion **11000** may be useful in aneurysms at a vessel bifurcation, for example, for deployment of the large pore sized distal lateral neck **11019** in the proximal M1 segment of the middle cerebral artery **11015** and the large pore sized distal medial neck **11018** in the A1 segment of the anterior cerebral artery **11025**, which can allow blood flow into these arteries, which can inhibit or prevent occlusion of blood flow to these arteries, which could otherwise lead to life-threatening stroke. In some embodiments, deployment of the small pore sized spherical distal bulb **11012** across the aneurysm **11005** in the distal internal carotid artery **11035** bifurcation can aid in thrombosis of the aneurysm **11005**. In some embodiments, deployment of the large pore sized proximal segment of the distal portion **11000**, including the wide-mouthed neck **11016**, the proximal elongate bulb **11014**, and the proximal neck **11017**, in the distal supra-clinoid internal carotid artery **11035** can allow blood flow into the branches arising from the distal supra-clinoid arteries, which can inhibit or prevent occlusion of blood flow to these arteries, which could otherwise lead to life-threatening stroke. In some embodiments, the force/resistance (e.g., radial force) of the bulbs and/or necks is in a range sufficient to slightly expand the target vessel(s) in the range of about 0% to about 30%, and the shapes of the bulbs and necks are at least partially preserved. In some embodiments, the radial force of the bulbs and/or necks is in a range sufficient to appose the sidewalls of the vessel to inhibit or prevent an endo-leak, but not sufficient to expand the vessel, and the shapes of the bulbs and necks are no longer preserved such that the shape of the distal portion **11000** is substantially tubular, whether tapered or non-tapered, for example based on the shape of the target vessel.

**[0834]** FIG. 28P is a schematic diagram of an example embodiment of the distal portion **11300** of FIG. 6H deployed across a side-wall aneurysm **503** in vasculature. The distal

portion **11300** may be useful, for example, for deployment of the small pore size second portion **11312** of the middle segment **11310** across a side-wall basilar arterial brain aneurysm **503**, which can aid in thrombosis of the aneurysm **503**. Deployment of the high pore size proximal segment **11315**, the high pore size distal segment **11305**, and the high pore size first portion **11311** of the middle segment **11310** across arteries **9460, 9465** proximal and distal to the aneurysm **503** can allow blood flow into these arteries, for example the proximal anterior-inferior cerebellar arteries, the distal basilar perforators, and/or the distal superior cerebellar arteries, which can inhibit or prevent occlusion of the basilar perforators and the other branches **9460, 9465** and/or resulting dysfunction, which could otherwise cause a brainstem stroke with paralysis of the arms and legs. In some embodiments, the force/resistance (e.g., radial force) of the bulbs and/or necks is in a range sufficient to slightly expand the target vessel(s) in the range of about 0% to about 30%, and the shapes of the bulbs and necks are at least partially preserved. In some embodiments, the radial force of the bulbs and/or necks is in a range sufficient to appose the sidewalls of the vessel to inhibit or prevent an endo-leak, but not sufficient to expand the vessel, and the shapes of the bulbs and necks are no longer preserved such that the shape of the distal portion **11300** is substantially tubular, whether tapered or non-tapered, for example based on the shape of the target vessel.

**[0835]** FIG. 28Q is a schematic diagram of an example embodiment of the distal portion **9900** of FIG. 6J deployed across a vascular malformation **507** in vasculature. The distal portion **9900** may be useful, for example, in vascular malformations such as an arterio-venous fistula **507**. For example, deployment of the high pore size segment **9902** in the transverse cerebral venous sinus and the high pore size proximal segment **9906** at the internal jugular vein near the base of skull can allow for normal venous drainage into these veins, which can inhibit or prevent occlusion of venous drainage from these venous sinuses (e.g., the vein of Labbe **9931**, the superior petrosal sinus **9932**, the inferior petrosal sinus **9934**, etc.), inadvertent occlusion of which could otherwise lead to life-threatening stroke. Deployment of the small pore size middle segment **9904** across the site **9933** of the arterio-venous fistula drainage into the sigmoid cerebral venous sinus can aid in thrombosis of the arterio-venous fistula **507**. The bulbs and wide-mouthed proximal and distal necks of the distal portion **9900** can provide good wall apposition in the cerebral venous sinuses and veins. In some embodiments, the force/resistance (e.g., radial force) of the bulbs and/or necks is in a range sufficient to slightly expand the target vessel(s) in the range of about 0% to about 30%, and the shapes of the bulbs and necks are at least partially preserved. In some embodiments, the radial force of the bulbs and/or necks is in a range sufficient to appose the sidewalls of the vessel to inhibit or prevent an endo-leak, but not sufficient to expand the vessel, and the shapes of the bulbs and necks are no longer preserved such that the shape of the distal portion **9900** is substantially tubular, whether tapered or non-tapered, for example based on the shape of the target vessel.

**[0836]** FIG. 29A is a schematic diagram of an example embodiment of the distal portion **11400** of FIG. 7C deployed across a fistula. A trans-femoral, trans-venous approach may be used to treating an arterio-venous fistula such as a carotid cavernous fistula. The femoral vein can act as a percutaneous entry point. As described above with respect to the catheter

angiogram, either leg can be used because both point towards the head, and, for peripheral lesions in one leg, the non-affected leg can be used.

[0837] Deployment of the distal portion **11400** may be as provided herein. A guide catheter and a dilator are partially inserted into the entry point. A steerable guidewire (e.g., having a length between about 150 cm and about 180 cm) is inserted into the guide catheter and the dilator, extending some distance (e.g., about 2 inches (approx. 5 cm)) out of the distal end of the dilator. The steerable guidewire can be advanced and steered for some distance, followed by advancement of the guide catheter and dilator over the steerable guidewire. The dilator is then removed. The steerable guidewire and the guide catheter can be sequentially advanced into the inferior vena cava, through the right atrium of the heart, into the brachiocephalic vein, until the desired point in the vasculature (e.g., internal jugular vein at the base of skull). The steerable guidewire is then removed, and the guide catheter is left in place. The desired point of the vasculature where advancement ceases may be the point where further advancement of the dilator could perforate the vasculature.

[0838] In some embodiments, referring again to FIG. 27A, a microcatheter **504** may be advanced over a steerable microwire **506** and through a guide catheter **502** positioned in the internal jugular vein at the base of skull proximal to the arterio-venous fistula. A steerable microwire **506** (e.g., having an outer diameter of about 0.014 inches (approx. 0.36 mm)) is inserted into the microcatheter **504**, extending some distance (e.g., about 2 cm to about 4 cm) out of the distal end of the microcatheter **504**. In some embodiments, a distal access microcatheter **530** is used and the microcatheter **504** is advanced over the microwire **506**. The microwire **506** can be advanced and steered for some distance into the sigmoid and transverse cerebral venous sinuses, followed by advancement of the microcatheter **504** over the microwire **506**. The microwire **506** and the microcatheter **504** can be sequentially advanced until the desired point in the vasculature (e.g., into the cavernous sinus). The microwire **506** is then removed or retracted while the microcatheter **504** is in position.

[0839] The distal portion **11400** may be useful, for example, as a flow disrupter in fistulas, which are abnormal communications between two hollow cavities. For example, if the distal portion **11400** in the cavernous venous sinus is deployed such that the low pore size bulbs **11435**, **11425** are in the left cavernous venous sinus **11455**, the low pore size bulbs are **11405**, **11415** in the right cavernous venous sinus **11450**, and the high pore size neck **11424** is between the two cavernous venous sinuses **11450**, **11455**, the low pore size segments can cause flow disruption by decreasing flow into the cavernous venous sinus, which can aid in thrombosis of the carotid-cavernous fistula. Deployment of the high pore size wide-mouthed neck **11424** between the two cavernous sinuses **11450**, **11455** can serve as a soft scaffold between the two cavernous venous sinuses **11450**, **11455**, which can aid in thrombosis of the carotid-cavernous fistula.

[0840] FIG. 29B is a schematic diagram of an example embodiment of the distal portion **11600** of FIG. 7D deployed in a cardiac wall aneurysm **11650**. A trans-femoral, trans-arterial approach may be used to treat a cardiac wall aneurysm **11650** such as a ventricular wall aneurysm. The femoral artery can act as a percutaneous entry point. As described

above with respect to the catheter angiogram, either leg can be used because both point towards the heart.

[0841] Deployment of the distal portion **11600** may be as provided herein. A guide catheter and a dilator are partially inserted into the entry point. A steerable guidewire (e.g., having a length between about 150 cm and about 180 cm) is inserted into the guide catheter and the dilator, extending some distance (e.g., about 2 inches (approx. 5 cm)) out of the distal end of the dilator. The steerable guidewire can be advanced and steered for some distance, followed by advancement of the guide catheter and dilator over the steerable guidewire. The dilator is then removed. The steerable guidewire and the guide catheter can be sequentially advanced into the descending abdominal aorta **11655**, through the aortic arch **11660**, until the desired point in the vasculature (e.g., the left ventricle **11665** of the heart). The steerable guidewire is then removed, and the guide catheter is left in place. The desired point of the vasculature where advancement ceases may be the point where further advancement of the dilator could perforate the vasculature. A ventriculogram of the heart may be performed using a 4 Fr (e.g., about 1.33 mm) or a 5 Fr (e.g., about 1.67 mm) pig-tail shaped diagnostic catheter advanced through the guide catheter, which is in stable position within the left ventricle **11665**. Dye comprising iodine (e.g., iohexyl, iodixanol, etc.) is injected through the pig-tail shaped diagnostic catheter for direct imaging of the ventricular wall aneurysm **11160**. The pig-tail catheter is then removed with the guide catheter in stable position within the left ventricle **11665**.

[0842] In some embodiments, referring again to FIG. 27A, a microcatheter **504** may be advanced over a steerable microwire **506** and through a guide catheter **502** positioned in the left ventricle **11665** proximal to the ventricular wall aneurysm **11160**. A steerable microwire **506** (e.g., having an outer diameter of about 0.014 inches (approx. 0.36 mm)) is inserted into the microcatheter **504**, extending some distance (e.g., about 2 cm to about 4 cm) out of the distal end of the microcatheter **504**. In some embodiments, a distal access microcatheter **530** may be used, and the microcatheter **504** is advanced over the microwire **506** and through the distal access microcatheter **530**. The microwire **506** can be advanced and steered for some distance into the ventricular wall aneurysm **11650**, followed by advancement of the microcatheter **504** over the microwire **506**. The microwire **506** and the microcatheter **504** can be sequentially advanced into the dome of the ventricular wall aneurysm **11650**. The microwire **506** is then removed or retracted while the microcatheter **504** is in position.

[0843] The distal portion **11600** may be useful, for example, in ventricular wall aneurysms **11650**. For example, deployment of the small pore size proximal bulb **11605** across the mouth of the ventricular wall aneurysm **11650** can cause flow disruption by decreasing flow into the ventricular wall aneurysm **11650**, which can aid in thrombosis of the ventricular wall aneurysm **11650**. Deployment of the high pore size middle bulb **11615** and high pore size distal bulb **11625** in the dome of the ventricular wall aneurysm **11650** can cause flow disruption within the aneurysm **11650** by forming a soft scaffold within the aneurysm **11650**, which can aid in thrombosis of the aneurysm **11650**. The distal neck **11606** is short and has a low braid angle, which can provide soft deployment of the distal portion **11600** within the dome of the aneurysm **11650**. The bulbs **11605**, **11615**, **11625**, the necks **11602**, **11604**, and

the distal neck **11606** of the distal portion **11600** can provide good wall apposition within the ventricular wall aneurysm **11650**.

[0844] FIG. 29C is a schematic diagram of an example embodiment of the distal portion **11500** of FIG. 7E deployed in the left atrial appendage **11530** of the heart. A trans-femoral, trans-venous approach may be used for occluding the left atrial appendage **11530**. The femoral vein can act as a percutaneous entry point. As described above with respect to the catheter angiogram, either leg can be used because both point towards the heart.

[0845] Deployment of the distal portion **11500** may be as provided herein. A guide catheter and a dilator are partially inserted into the entry point. A steerable guidewire (e.g., having a length between about 150 cm and about 180 cm) is inserted into the guide catheter and the dilator, extending some distance (e.g., about 2 inches (approx. 5 cm)) out of the distal end of the dilator. The steerable guidewire can be advanced and steered for some distance, followed by advancement of the guide catheter and dilator over the steerable guidewire. The dilator is then removed from the distal inferior vena cava. The steerable guidewire and the guide catheter can be sequentially advanced into the inferior vena cava, through the right atrium of the heart, and, if the foramen ovale is patent, then the guide catheter is advanced over the steerable guidewire from the right atrium into the left atrium until the desired point in the vasculature (e.g., the left atrium of the heart proximal to the left atrial appendage **11530**). The steerable guidewire is then removed, and the guide catheter is left in place. If a pre-existing foramen ovale is not patent, then a percutaneous entry into the superior vena cava can be performed. Using a needle and stylet, an iatrogenic hole or perforation is created near the fossa ovalis in the septal wall of the atrium.

[0846] In some embodiments, referring again to FIG. 27A, a microcatheter **504** may be advanced over a steerable microwire **506** and through a guide catheter **502** positioned in the left atrium proximal to the orifice of the left atrial appendage **11530**. A steerable microwire **506** (e.g., having an outer diameter of about 0.014 inches (approx. 0.36 mm)) is inserted into the microcatheter **504**, extending some distance (e.g., about 2 cm to about 4 cm) out of the distal end of the microcatheter **504**. In some embodiments, a distal access microcatheter **530** may be used, and the microcatheter **504** is advanced over the microwire **506** and through the distal access microcatheter **530**. The microwire **506** can be advanced and steered for some distance into the mouth of the left atrial appendage **11530**. The microwire **506**, and the microcatheter **504**, can be sequentially advanced dome of the left atrial appendage **11530**. The microwire **506** is then removed or retracted while the microcatheter **504** is in position.

[0847] The distal portion **11500** may be useful, for example, as a flow disrupter in the left atrial appendage **11530** within the heart. For example, deployment of the small pore size proximal bulbs **11512**, **11514** across the mouth of the left atrial appendage **11530** can cause flow disruption by decreasing flow into the left atrial appendage **11530**, which can aid in thrombosis of the left atrial appendage **11530**, which can decrease the risk of stroke in patients with atrial fibrillation and/or reduce or eliminate the need for long term anti-coagulation. Deployment of the high pore size distal bulbs **11516**, **11518** inside the dome of the left atrial appendage **11530** can cause flow disruption within the left atrial appendage **11530**

by forming a soft scaffold within the left atrial appendage **11530**, which can aid in thrombosis of the left atrial appendage **11530**. The distal neck **65** is short and has a low braid angle, which can provide soft deployment of the distal portion **11500** within the dome of the left atrial appendage **11530**. The proximal neck **11522** is short and has a high braid angle, which can inhibit or prevent any blood flow into the dome of the left atrial appendage **11530**. The bulbs and the wide mouthed necks between the bulbs of the distal portion **11500** can provide good wall apposition within the left atrial appendage **11530**.

[0848] The distal portions **100** described herein that are deployed in vasculature may be releasably or non-releasably coupled to a proximal portion **200**. For example, after positioning at the site of the vasculature, the distal portion **100** may be mechanically, electrolytically, chemically, etc. released to act as an endoprosthesis. For another example, after positioning at the site of the vasculature, the distal portion **100** may remain only for so long as the treatment takes place, whereupon it may be removed. In certain such embodiments, for example, the distal portion **100** may act as a scaffolding during insertion or packing of coils or other embolic material (e.g., fluid such as Onyx®, available from Covidien) into an aneurysm.

[0849] The devices **10**, **20**, **30**, **40** described herein may be gentle and safe on the fragile human blood vessels, customizable by a user to the length of the clot or clot burden, visible under X-ray fluoroscopy, reach the smallest of human blood vessels, compatible with torsional rasping of the clot, have bonding zones or attachment points that are strong even between dissimilar metals or alloys to avoid the risk of any fracture points, and/or include proximal portions **200** that provide good proximal support and good distal flexibility. Some embodiments can provide one or more, or all, of the advantages described herein.

[0850] Although described herein in detail with respect to blood vessels, the devices and methods described herein can be used in any appropriate part of the body, for example having a lumen (e.g., blood vessels (e.g., cardiac, peripheral, neuro), biliary ducts, digestive or gastrointestinal tracts, pulmonary tracts, etc.).

[0851] In some embodiments, the devices and methods described herein can be used in conjunction with drug therapy. For example, a drug or agent (e.g., r-tpa, heparin, taxol, etc.) can be injected through the microcatheter, through the lumen of the proximal portion **200** and/or a lumen created by the textile structure **158** of the distal portion **100**, or separately before, during, or after deployment of at least a segment of the distal portion **100**.

[0852] The following references are herein incorporated by reference in their entirety: (1) SARTI et al., Int'l trends in mortality from stroke, 1968 to 1994, *Stroke*, 2000, vol. 31, pp. 1588-1601; (2) WOLF et al., Epidemiology of Stroke, In: BARNETT et al., eds., *Stroke: Pathophysiology, Diagnosis, and Management*, 3rd Ed., New York, N.Y.: Churchill Livingstone, 1998, pp. 6-7; (3) ADAMS et al., Guidelines for the early management of patients with ischemic stroke: A scientific statement from the Stroke Council of the American Stroke Association, *Stroke*, 2003, vol. 34, pp. 1056-1083; (4) RYMER et al., Organizing regional networks to increase acute stroke intervention, *Neurol. Res.*, 2005, vol. 27, pp. 9-16; and (5) FURLAN et al., Intra-arterial prourokinase for acute ischemic stroke; The PROACT II study: A randomized

controlled trial, Prolyse in Acute Cerebral Thromboembolism, *JAMA*, 1999, vol. 282, pp. 2003-2011.

[0853] While the invention is susceptible to various modifications, and alternative forms, specific examples thereof have been shown in the drawings and are herein described in detail. It should be understood, however, that the invention is not to be limited to the particular forms or methods disclosed, but to the contrary, the invention is to cover all modifications, equivalents, and alternatives falling within the spirit and scope of the various embodiments described and the appended claims. Any methods disclosed herein need not be performed in the order recited. The methods disclosed herein include certain actions taken by a practitioner; however, they can also include any third-party instruction of those actions, either expressly or by implication. For example, actions such as "torsionally rasping a distal portion of a thrombectomy device" include "instructing the torsionally rasping of a distal portion of a thrombectomy device." The ranges disclosed herein also encompass any and all overlap, sub-ranges, and combinations thereof. Language such as "up to," "at least," "greater than," "less than," "between," and the like includes the number recited. Numbers preceded by a term such as "about" or "approximately" include the recited numbers. For example, "about 3 mm" includes "3 mm."

- 1. A vascular device comprising:
  - a wire having a first austenitic finish temperature and comprising a first shape set;
  - a hypotube distal to the wire,
    - the hypotube comprising a lumen, a portion of the wire non-releasably coupled inside the lumen of the hypotube at a joint,
    - the hypotube having a second austenitic finish temperature and comprising a second shape set,
    - the second austenitic finish temperature different than the first austenitic finish temperature; and
  - a textile structure coupled to the hypotube,
    - the textile structure comprising a plurality of bulbs and a plurality of necks.
- 2. The device of claim 1, wherein the first shape set is different than the second shape set.
- 3. A vascular device comprising:
  - a wire having a first austenitic finish temperature and comprising a first shape set; and
  - a tubular member comprising a lumen, the tubular member having a second austenitic finish temperature and comprising a second shape set, the second austenitic finish temperature different than the first austenitic finish temperature, a portion of the wire non-releasably coupled inside the lumen of the tubular member at a joint.
- 4. The device of claim 3, wherein the tubular member comprises:
  - a first longitudinal section having the second austenitic finish temperature and comprising the second shape set; and
  - a second longitudinal section having a third austenitic finish temperature and comprising a third shape set, the third austenitic finish temperature different than the second austenitic finish temperature.
- 5. The device of claim 3, wherein the tubular member is distal to the wire.
- 6. The device of claim 3, wherein the first shape set is different than the second shape set.

- 7. The device of claim 3, wherein the tubular member comprises a hypotube.
- 8. The device of claim 3, wherein the tubular member comprises a braided tubular structure.
- 9. The device of claim 3, further comprising a textile structure coupled to the tubular member, the textile structure comprising a plurality of bulbs and a plurality of necks.
- 10. The device of claim 3, wherein the tubular member comprises a cut pattern.
- 11. A vascular device comprising:
  - a tubular element comprising a plurality of longitudinal sections, the plurality of longitudinal sections including:
    - a first longitudinal section having a first austenitic finish temperature, and
    - a second longitudinal section having a second austenitic finish temperature different than the first austenitic finish temperature, the second longitudinal section distal to the first longitudinal section; and
  - a textile structure non-releasably coupled to the tubular element, the textile structure comprising a plurality of bulbs and a plurality of necks, the textile structure distal to the second longitudinal section.
- 12. The device of claim 11, wherein the plurality of longitudinal sections further comprises:
  - a third longitudinal section having a third austenitic finish temperature different than the first austenitic finish temperature and the second austenitic finish temperature; and
  - a fourth longitudinal section having a fourth austenitic finish temperature different than the first austenitic finish temperature, the second austenitic finish temperature, and the third austenitic finish temperature.
- 13. The device of claim 11, wherein the first longitudinal section comprises a first material and the second longitudinal section comprises a second material different than the first material.
- 14. The device of claim 11, wherein the first longitudinal section comprises a first material and the second longitudinal section comprises the first material.
- 15. The device of claim 11, wherein the first longitudinal section comprises a first shape set and the second longitudinal section comprises a second shape set different than the first shape set.
- 16. The device of claim 11, wherein the first longitudinal section comprises a first shape set and the second longitudinal section comprises the first shape set.
- 17. The device of claim 11, wherein the second longitudinal section is distal to the first longitudinal section, and wherein the first longitudinal section is configured to provide torquability and the second longitudinal section is configured to provide flexibility.
- 18. The device of claim 11, wherein at least one of the first longitudinal section and the second longitudinal section is shape set to a straight configuration.
- 19. (canceled)
- 20. The device of claim 11, wherein the tubular element comprises a cut pattern.
- 21. The device of claim 1, wherein the hypotube comprises a cut pattern.

\* \* \* \* \*