

(No Model.)

A. L. CLARKE.
CAR FENDER.

No. 522,194.

Patented July 3, 1894.

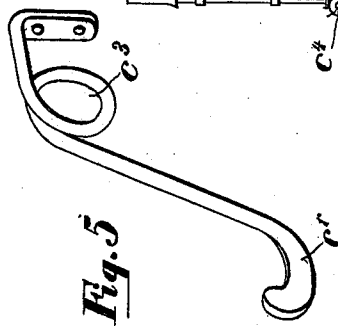
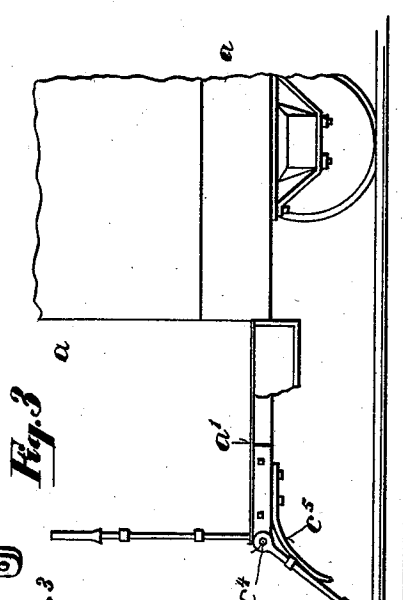
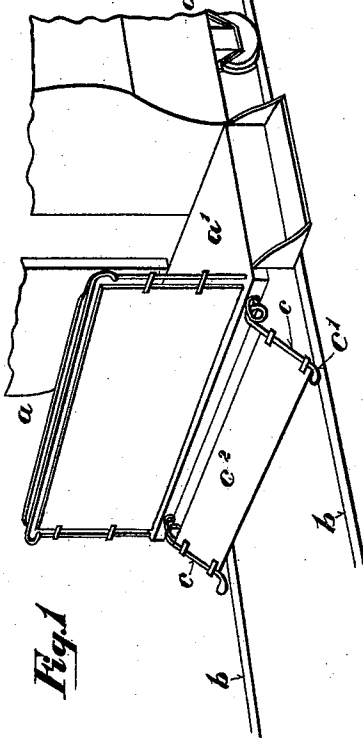
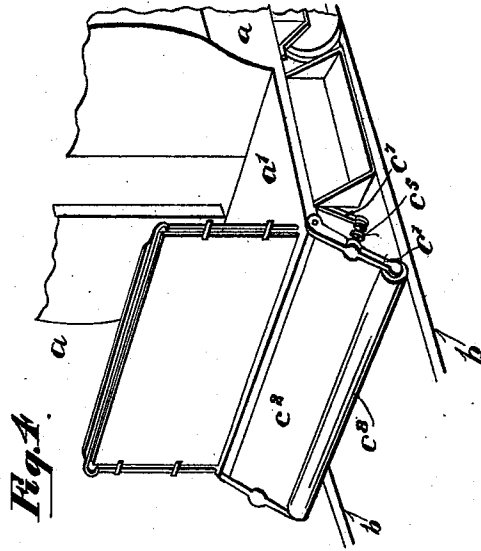
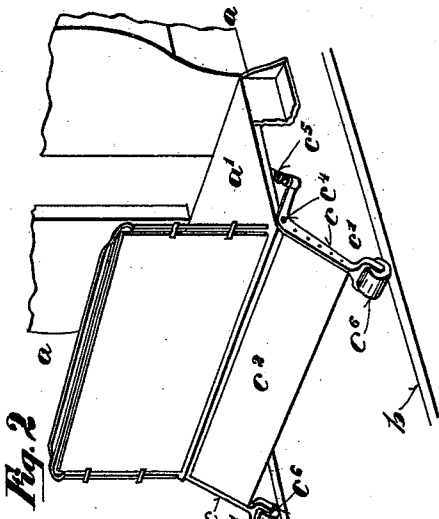

WITNESSES:
Fred Ernest
Frankl batt

INVENTOR
Alfred L. Clarke
 BY *Wm. H. Shepherd*
 ATTORNEYS

UNITED STATES PATENT OFFICE.

ALFRED L. CLARKE, OF SPRINGFIELD, OHIO.

CAR-FENDER.

SPECIFICATION forming part of Letters Patent No. 522,194, dated July 3, 1894.

Application filed June 5, 1893. Serial No. 476,674. (No model.)

To all whom it may concern:

Be it known that I, ALFRED L. CLARKE, a citizen of the United States, residing at Springfield, in the county of Clark and State of Ohio, have invented a certain new and useful Improvement in Car-Fenders, of which the following is a specification.

My invention relates to improvements in car-fenders, and it especially relates to devices adapted to be attached to the ends of railway cars, especially such as are used on street railways.

The especial object of the invention is to provide a yielding fender or guard adapted to normally stand above the rails and to extend across the front of the car.

The invention consists in the various constructions and combinations of parts herein-after described and pointed out in the claims.

In the accompanying drawings Figure 1 is a perspective view, illustrating a portion of a street car to which my invention is attached. Fig. 2 is a similar view, showing the guard in a slightly modified form. Fig. 3 is a side elevation of the same, showing a different modification. Fig. 4 is a perspective view, showing the parts further modified. Fig. 5 is a detail view of a portion of the device shown in Fig. 1.

Like parts are represented by similar letters of reference in the several views.

In the said drawings *a*, represent the body of the car, and *a'*, the platform.

b, *b*, are the track rails.

Connected directly to the front of the platform, on the opposite sides of the car, are yielding arms *c*, *c*, which extend outwardly and downwardly from the front of the car and are provided at the lower end with contacting portions *c'*, *c'*, normally supported directly above the track rails *b*, *b*. These yielding arms *c*, *c*, are each connected to the opposite extremities of a guard table or cover *c²*, which extends from near the bottom of the platform *a'*, to a point slightly above the track rails *b*. As before stated the arms *c*, *c*, are yielding and are normally held out of contact with the track rails; the construction being such that a slight pressure thereon or on the table *c²*, will cause the contacting portions *c'*, of said arms to contact with the track rails *b*, *b*, and travel thereon, thus bringing

the table *c²*, into close proximity to the surface of the road bed and effectually prevent anything from passing under said table. This table or guard always stands at an angle to the track rails and to the direction of travel of the car, so that a forward motion of the car tends to move any object which may come in contact with the guard or table, and raise it from the track.

In Fig. 1 I have shown the yielding arms *c*, each formed of a single piece of metal, preferably of spring steel, having a coil *c³*, to afford the necessary elasticity to sustain the table above the track and to permit the arms to yield downwardly in contact with the track in the operation of the device; the lower end of each of the arms being curved, as shown in Fig. 5, in the nature of a shoe, to form the bearing portion *c'*. In Fig. 2 the arms are each formed in the nature of bell crank levers, and pivoted at *c⁴*, with springs *c⁵*, extending between the inner ends of said arms and the car platform; the lower extremities of the arms being bifurcated and provided with rollers *c⁶*, which form the contacting portions of said arms. In Fig. 3 the lower extremities of the arms are formed in the nature of shoes, the same as in Fig. 1, the arms being pivoted at *c⁴*, as in Fig. 2, and a spring *c⁵*, secured to the platform, being adapted to press directly against the body of the arm *c*. In Fig. 4 the arms are pivoted, and a spring *c⁵*, is arranged between the arms, and an auxiliary arm or bearing support *c⁷*, on the platform; the respective arms being in this case connected by a continuous roller *c⁸*, arranged at the lower edge of the table *c²*, and adapted to form the contacting portion of the said arms.

It will be seen that by the above construction I form a fender which is normally supported above the track but which is adapted to yield to come in contact with the track and travel thereon, so as to bring the lower edge of the fender table in proximity to the surface of the road bed whenever a pressure is exerted thereon; the fender or table being in this position always at a uniform height above the track or road bed.

Having thus described my invention, I claim—

1. The combination with a railway car, of

yielding arms secured directly to the front of
said car, said arms each consisting essentially
of a single piece of metal having a spring
coil therein, and provided at the lower end
5 with a bearing portion or shoe, as described,
and a guard or table arranged between the
respective arms, and secured thereto, substan-
tially as and for the purpose specified.

2. The combination with a railway car, of
10 a fender, consisting essentially of an inclined
guard or table supported at each end by yield-
ing arms which are arranged above the track

rails on which said car travels, said yielding
arms being each normally supported above
said track rails and provided with bearing 15
portions adapted to contact with said track
rails by a downward yielding movement of
said arms, substantially as and for the pur-
pose specified.

ALFRED L. CLARKE.

In presence of—
ROBERT C. RODGERS,
FRANK WATT.