

Oct. 8, 1929.

J. W. BRYCE

1,730,448

PNEUMATIC CLOCK SYSTEM

Filed June 25, 1925

3 Sheets-Sheet 1

Fig. 1.

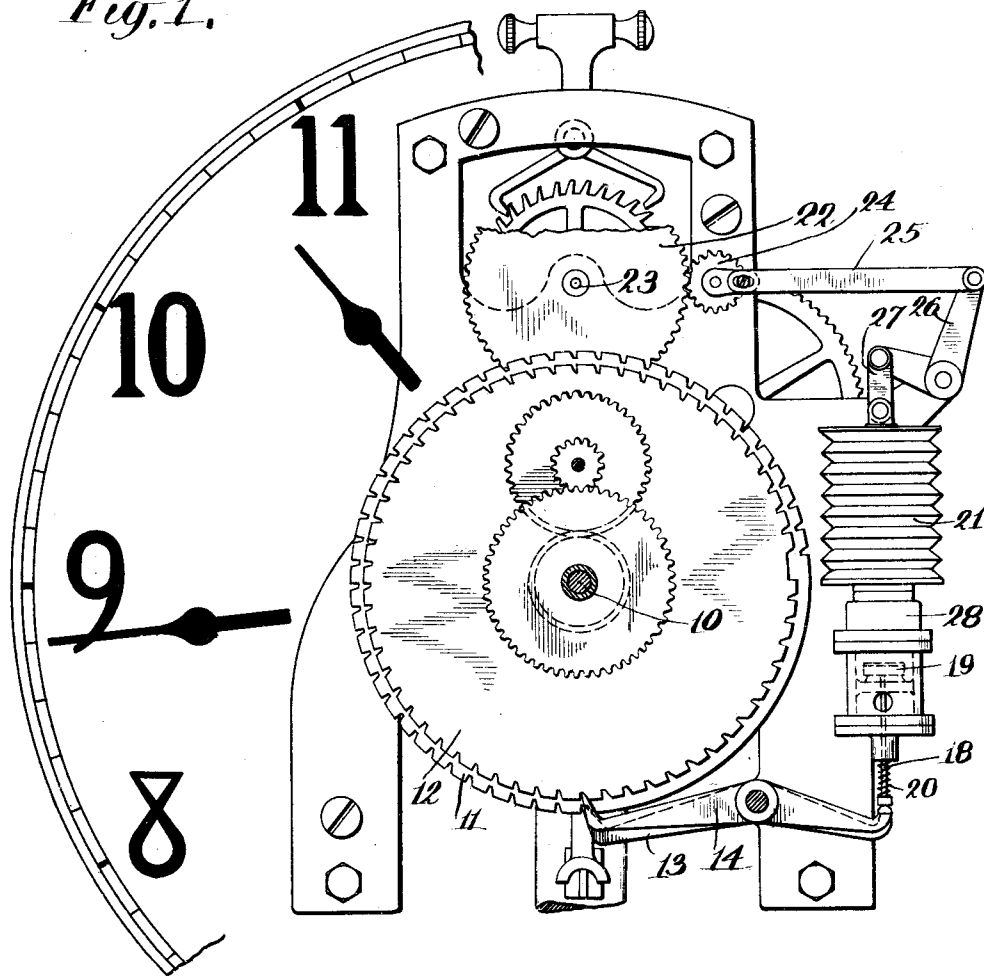

Inventor
James W. Bryce
By *his* Attorneys
Cooper, Kern & Steinhilber

Oct. 8, 1929.

J. W. BRYCE

1,730,448

PNEUMATIC CLOCK SYSTEM

Filed June 25, 1925

3 Sheets-Sheet 2

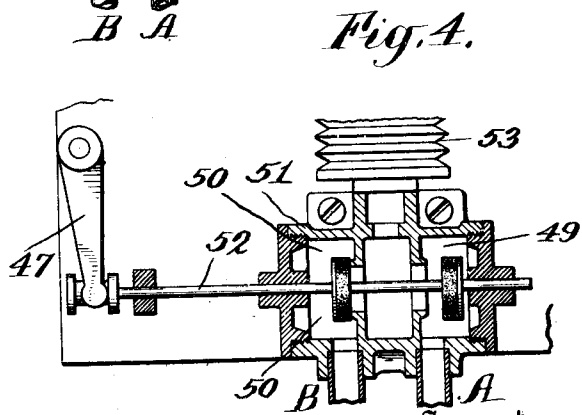
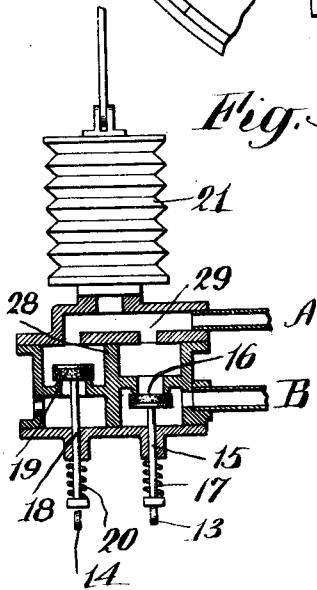
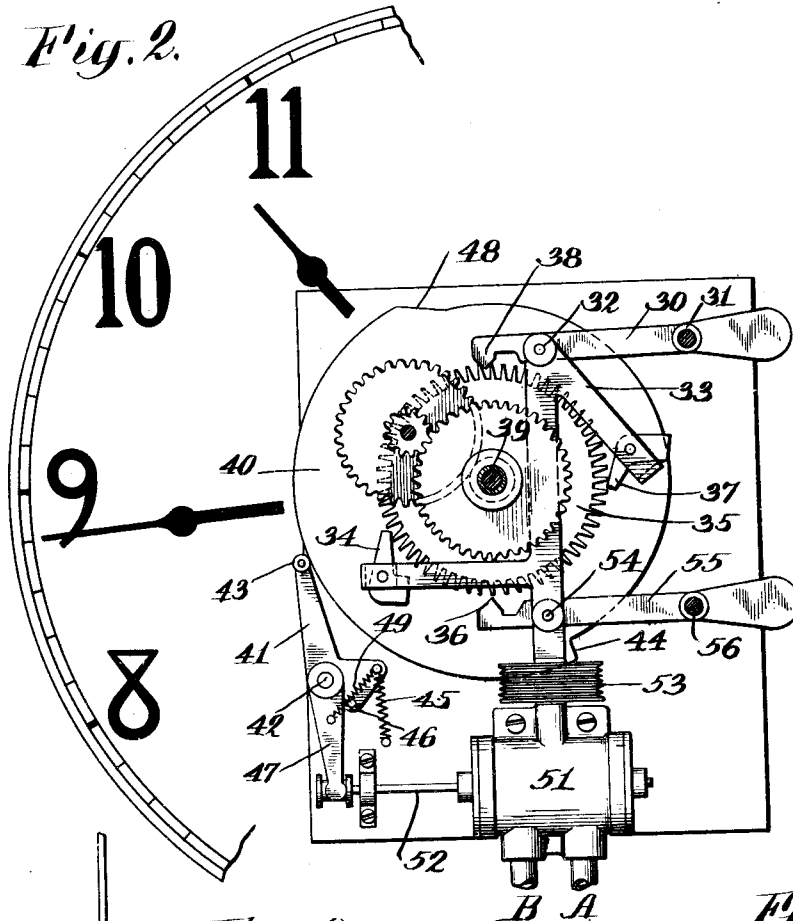

Inventor
James W. Bryce

By his Attorneys
Cooper, Rice & Drickman

UNITED STATES PATENT OFFICE

JAMES W. BRYCE, OF BLOOMFIELD, NEW JERSEY, ASSIGNOR TO INTERNATIONAL TIME RECORDING COMPANY OF NEW YORK, OF ENDICOTT, NEW YORK, A CORPORATION OF NEW YORK

PNEUMATIC CLOCK SYSTEM

Application filed June 25, 1925. Serial No. 39,551.

This invention relates to a synchronized clock system, and more particularly to a pneumatic clock system and to the means by which a plurality of secondary clocks are brought into synchronism with a master clock.

The primary object of my invention is to provide a pneumatic clock system wherein the secondary clocks may be maintained in or brought to substantially perfect synchronism with the master clock from any condition of asynchronism within limits; whether they be initially out of step with the master clock or brought so by accident or design.

Other objects reside in the production of a master clock that will actuate pneumatic bellows to distribute energy to various secondary clocks by means of fluid pressure or displacement and to control the recurrence of pressure waves in fluid so as to cause rapid advance of any secondary clock which may be behind time.

Another object resides in the production of a secondary clock which will receive the actuating energy in the form of fluid pressure or displacement and, by its operation and determined by its state of synchronism or asynchronism, control its own actuation. Provision is made for receiving impulses, by which term I shall refer hereinafter to the actuating energy conveyed in the form of fluid pressure or displacement, that will actuate the secondary clock step-by-step in conformity with the time indication of the master clock, and prevent the receipt of said impulses at a predetermined time whenever the secondary clock is fast and its hands reach the predetermined time indication prior to the actual time as maintained by the master clock.

The above stated objects may be accomplished in various manners involving different time relations for the synchronizing period, as for example allowing a period for accelerating the advance of secondary clocks of greater or lesser duration depending upon the choice of the user.

Other objects involving novel constructions and combinations of parts will appear in the specification and in the claims thereof set-

ting forth a preferred embodiment of my invention which will be fully understood from the detailed description and drawings, in which

Fig. 1 is a front elevational view of the controlling and driving mechanisms in the master clock;

Fig. 2 is a front elevational view of the controlling mechanism in a secondary clock;

Fig. 3 is a detail of the valve and bellows of the master clock;

Fig. 4 is a detail of the valve of a secondary clock; and

Fig. 5 is a diagrammatic showing of the system with a master clock in driving relation to three secondary clocks.

For the purpose of clarity in understanding I have illustrated my invention in the most convenient timing relations, and briefly stated, it consists of sending a series of normal impulses from a master clock to a secondary clock over either one of two conduits. At forty-four minutes after the hour the master clock shuts off one of these conduits and continues to send the regular normal impulses over the other. Just after the fifty-ninth minute a series of quick or accelerating impulses are sent to the secondary clock. All of the above described distribution of impulses from the master clock is controlled by the master clock and the utilization of these impulses by a secondary clock is under the control of the secondary clock itself. If the secondary clock indicates the same hour as the master clock at all times each of the normal impulses distributed by the master clock will be effective to step the secondary clock along with the master clock and the series of accelerating impulses during the last minute will not be operative to produce any effect in the operation of the secondary clock.

If the secondary clock is slow, the accelerating impulses will reach the secondary clock and thereby advance it to the hour point the amount which it was slow. The impulse sent out on the hour will then cause the secondary clock to be stepped along in synchronism with the master clock and each succeeding normal impulse will have the effect of keep-

ing the driven clock at the same time indication as the driving clock.

Master clock

5 The master clock in its general details may be of any approved construction including the usual time train adapted to drive the minute hand arbor 10 which makes one revolution per hour. Only so much of the old and well known structure is illustrated as is necessary to fully understand and construct the present subject matter of invention.

10 Cam discs 11 and 12 are mounted on shaft 10. In the present embodiment of the invention the periphery of cam disc 11 has notches therein placed at minute intervals from and including the sixtieth minute to and including the forty-fourth minute period. The periphery of cam disc 12 has notches therein placed at minute intervals from and including the sixtieth minute to and including the fifty-ninth minute with the fifty-ninth and sixtieth minute interval notches merged into one large notch. Cam disc 11 controls the position of lever 13 and cam disc 12 controls the position of lever 14.

15 The right end of lever 13 contacts with the lower end of valve stem 15, Fig. 3, of valve 16. A spring 17 coiled around the valve stem tends to keep valve 16 away from its seat and the left end of lever 13 in contact with the periphery of disk 11. The right hand end of lever 14 contacts with the lower end of valve stem 18 of valve 19. Spring 20 coiled around the valve stem tends to keep valve 19 closed and the left end of lever 14 in contact with the periphery of disk 12.

20 In the preferred embodiment, valves 16 and 19 are mounted in the same valve box and they are effectual to control the distribution of fluid pressure and displacement from bellows 21 which is opened and closed four times a minute by means of gear 22, fast to arbor 23 which makes one revolution per minute. Pinion 24 is driven by gear 22 and it actuates link 25 to oscillate bell crank lever 26 which is connected to bellows 21 by link 27.

25 The lower end of bellows 21 is connected to valve box 28 having a chamber 29 which permits of continuous communication with conduit A. Valve 16 controls the connection of conduit B with chamber 29 and the bellows, and valve 19 is a relief valve which opens to the atmosphere.

30 Conduits A and B are the conduits which control the effect of the fluid pressure and displacement to the secondary clocks (Fig. 5), and disk 11 is designed to position lever 13 so as to maintain valve 16 closed during the synchronizing period and thus close off conduit B.

35 In the present embodiment, I provide for a synchronizing period commencing just after the minute hand of the master clock is forty-

four minutes after the hour and terminating just prior to the sixtieth minute.

70 In the operation of the master clock, for each minute from the sixtieth minute to the forty-fourth minute inclusive, valve 16 will be unseated and valve 19 will be seated for the first quarter of a minute and then their respective positions will be reversed for the remaining three-quarters of the minute. This timing permits the effect of a single opening and closing movement of bellows 21 to be transmitted to the secondary clocks through either of conduits A or B during the first quarter of a minute. The remaining three complete movements of the bellows are non-effective since valve 19 is opened to the atmosphere.

75 Valve 16 closes conduit B off entirely for a period from just after the forty-fourth minute to just prior to the sixtieth minute and for each minute from the forty-fifth to the fifty-ninth inclusive, valve 19 will continue to be seated during the first quarter of each minute, and the effect of a single opening and closing of bellows 21 per minute will be transmittible over conduit A. This single opening and closing of the bellows comprises the energy initiating function which results in recurring pressure waves herein called impulses.

80 As is apparent from an observation of Fig. 1, valve 19 will remain seated for the fifty-ninth and sixtieth minute impulses and for all of the impulses in between so that the secondary clocks will be furnished with a series of fast or accelerating impulses to advance those which are slow in a manner to be described hereinafter. For the sixtieth minute and thereafter the master clock will repeat the series of operations just described.

Secondary clock

85 The secondary clock shown in Fig. 2 is designed to be driven by the master clock, and to utilize the impulses sent out by the master clock to keep itself synchronized.

90 The A and B conduits each have branches which lead into chambers 49 and 50 respectively of valve case 51 and a duplex valve 52 is provided for shutting off either one of these chambers from communication with bellows 53 of the secondary clock. The lower end of the bellows is connected to the valve case, and the upper end is pivotally connected by pin 54 to arm 55 journaled on stud 56. Directly above arm 55, an arm 30 is journaled on stud 31 and this arm is pivotally connected by pin 32 to frame 33 which is also connected to arm 55 by means of pin 54. Frame 33 carries a pawl 34 which cooperates with the teeth on escapement wheel 35 to advance it half a tooth. Nose 36 on arm 55 serves to lock the escapement wheel in its changed position. When bellows 53 collapses, pawl 37 operates to advance the escapement wheel an-

other half a tooth and nose 38 on arm 30 enters between the next pair of teeth at the completion of the movement and locks the escapement wheel from further rotation. The escapement wheel is secured to the minute hand arbor 39 which makes one revolution per hour. The usual transmission gearing is provided to actuate the hour hand from this arbor.

A cam disk 40 turns with the minute hand arbor and it controls the position of duplex valve 52. Bell crank lever 41 is pivotally mounted on pin 42 and carries roller 43 which engages the periphery of cam disk 40. Just after the secondary clock has been advanced to the fifty-ninth minute, bell crank 41 will be drawn off the high portion 44 of cam disk 40 by spring 45 and stud 46 will contact with arm 47 and swing it clockwise about pin 42 to cause duplex valve 52 to be moved to its extreme left position to shut off chamber 49 from communication with bellows 53.

Sometime before the synchronizing period starts, as for example, at about thirty minutes past the hour, bell crank 41 will be moved to the left by slope 48 and arm 47 will be drawn counterclockwise by spring 49, thus causing the duplex valve to shut out chamber 50 and throw conduit A into communication with bellows 53, Fig. 4. The snap action provided by bell-crank 41 and arm 47 allows for rapid and accurate operation of the valve without having any intermediate position.

Operation

The first operation to be described will be the normal minute impulse operation for controlling the secondary clocks. For clarity, it will be assumed that all of the clocks are at a position somewhere between the hour reading and forty-four minutes later. During this period of time, there is a notch in each disk 11 and 12 for each minute and when the left ends of levers 13 and 14 enter these notches an impulse consisting of a single opening and closing of bellows 21 will be transmitted over either conduit A or conduit B to operate bellows 53. The choice of conduits depends upon the position of valve 52 in each of the secondary clocks. The remaining three impulses of a single minute are dissipated into the atmosphere when valve 19 is opened by the effect of having lever 14 ride upon the peripheral edge of disk 12. Thus, each minute one of the four impulses from the master clock will serve to advance the secondary clocks one step.

During the synchronizing period which starts just after the forty-fourth minute, lever 13 will ride continuously upon the peripheral edge of disk 11 and valve 16 will remain closed thereby shutting off conduit B as an active transmitting conduit. The minute impulses will continue to be sent out over the A conduit to all secondary clocks

which are on time or are not more than about fifteen minutes slow (Fig. 5). This length of time is an arbitrary limit which may be lengthened if desired, for it is dependent upon the position of slope 48.

The duplex valves in both the "on time" and "slow" clocks will be in a right hand position thereby permitting the minute impulses coming over conduit A to be effective to operate bellows 53.

When a clock is fast it will shut itself off from the impulses at the fifty-ninth minute position by the closing off of conduit A by the duplex valve. This action throws in conduit B but conduit B is shut off by valve 16 at the master clock and no impulses can reach the stopped secondary clock until the sixtieth minute impulse is sent out over conduit B.

The clocks that are slow will continue to operate step-by-step and between the fifty-ninth and sixtieth minute impulses they each will receive a series of fast or accelerating impulses from the master clock which will step them ahead rapidly. This result is produced by a complete closing of valve 19 during this minute thereby making all of the movements of bellows 21 effective. When a slow clock has been advanced to the fifty-ninth minute position, Fig. 4, it will stop, and then all of the secondary clocks will step out together on the sixtieth minute.

It will be understood that if in any case it is required to correct the time of the entire system, as for example when the master clock is running fast or slow, and this correction is to be within the range permitted by the synchronizing period, it is only necessary to reset the hands of the master clock to the desired extent. The secondaries will then set themselves beginning with the next synchronizing period. If the amount is in excess of the synchronizing period for which the system is designed, for example when a daylight saving correction is required, it would be necessary to slide lever 14 on its pivot out of the plane of disk 12 and thereby cause valve 19 to remain seated until the secondary clocks had been advanced the desired amount. It is probable that someone might desire a greater rate of advance of the secondary clocks than that capable of being rendered by the master clock herein disclosed, and in such case, it would only be necessary to alter the master clock so as to render it capable of sending out a greater number of impulses per unit of time. It is also obvious that a supplemental motor, clock or like device capable of sending out a plurality of fast impulses could have connections with the conduits so as to deliver thereto, when desired, any number of fast impulses necessary to make the desired correction.

For stopping the secondaries for a period of time it is only necessary to lift valve 19

from its seat until that period of time has elapsed.

In either event, it would not be essential to alter the normal operation of valve 19 until the exact setting of the secondaries is obtained, for the synchronizing system will function to bring the clocks in time with the master clock whether they are fast or slow with respect to the master clock. It is only necessary that they be brought within the range of the synchronizing period.

While in the present embodiment I have selected a synchronizing period of nearly sixteen minutes, it will be understood that this period is given merely for purposes of illustration and that this period may be greater or lesser, as desired. In clock systems of the present day this period has been found to be ample for all purposes.

In the present system it will be apparent that the master clock sends out over either one of two conduits normal impulses produced by the opening and closing of its bellows for a definite period and then automatically shuts off one of these conduits and sends out normal and fast impulses during another period of time which corresponds to the synchronizing period.

The synchronization of the secondary clocks is dependent upon the utilization of the impulses sent out by the master clock, and the utilization is dependent on the devices contained in the secondary clock and its own chronologic condition. These devices selectively determine whether the secondary clocks shall receive normal impulses, fast impulses, or whether they be connected so as not to receive any impulses for a time.

While the form of mechanism herein shown and described is admirably adapted to fulfill the objects primarily stated, it is to be understood that it is not intended to confine the invention to the one form of embodiment herein disclosed, for it is susceptible of embodiment in various forms all coming within the scope of the claims which follow.

What I claim is—

1. In a synchronizing system, the combination of a plurality of conduits, a master clock having means for controlling the distribution of fluid pressure over said plurality of conduits, a plurality of secondary clocks connected across said conduits each having a device for determining which of the plurality of conduits will be connected with a secondary clock, and means adapted to respond to changes in fluid pressure for controlling the operation of each of said secondary clocks.

2. In a synchronizing system, the combination of a master clock having means for causing a variation in fluid pressure, a plurality of conduits having connections with said means, means for closing off one of said conduits from said first mentioned means, a plurality of secondary clocks connected across

said conduits each having a device for determining which of the plurality of conduits will be connected with a secondary clock, and means adapted to respond to changes in fluid pressure for controlling the operation of each of said secondary clocks.

3. In a synchronizing system, the combination of a plurality of conduits, a master clock having means for controlling the distribution of fluid displacement over said plurality of conduits, a plurality of secondary clocks having connections with said conduits, means for causing a displacement of fluid in said conduits, means associated with each secondary clock subject to being affected by said fluid displacement in said conduits, and clock actuating mechanism controlled by said last mentioned means.

4. In a synchronizing system, the combination of a plurality of conduits, a master clock having means for controlling the distribution of fluid displacement over said plurality of conduits, a plurality of secondary clocks having connections with said conduits, means for causing a displacement of fluid in said conduits, means connected to said conduits for actuating each secondary clock, and controlling means for determining which of said plurality of conduits will be connected to a secondary clock.

5. The combination set forth in claim 4 in which the last mentioned controlling means is controlled by the secondary clock.

6. In a synchronizing system, the combination of a plurality of conduits, a master clock having means for controlling the distribution of fluid displacement over said plurality of conduits, a plurality of secondary clocks having connections with said conduits, means for causing a displacement of fluid in said conduits, means associated with each secondary clock subject to being affected by said fluid displacement in said conduits, means for determining which of said conduits will be connected to said last mentioned means, and clock actuating mechanism connected to said means affected by fluid displacement.

7. The combination set forth in claim 6 in which the means for determining which of the conduits will be connected with the secondary clock means subject to being affected by fluid displacement is controlled by the chronologic condition of the secondary clock.

8. In a synchronizing system, the combination of a plurality of conduits, a master clock having means for controlling the distribution of fluid pressure over said plurality of conduits, a secondary clock having connections to each of said conduits, means in said secondary clock adapted to be actuated by fluid pressure, and means for connecting one of said plurality of conduits with said secondary clock.

9. The combination set forth in claim 8 in

which said last mentioned means is controlled by the secondary clock.

10. In a synchronizing system, the combination of a master clock having means for initiating pressure energy, means for selectively relieving some of said pressure and forming the remainder into recurring impulses, a plurality of conduits, means for controlling the distribution of said impulses to said conduits, and a secondary clock connected to said conduits adapted to receive impulses from said conduits.

11. In a synchronizing system, the combination of a master clock having means for initiating pressure energy, means for selectively relieving some of said pressure and forming the remainder into recurring impulses, a plurality of conduits, means for controlling the distribution of said impulses to said conduits, a secondary clock having connections to each of said conduits, means operable by said impulses to actuate said secondary clock, and means for controlling the connections of said secondary clock with said conduits.

12. The combination set forth in claim 11 in which said last named means is controlled by the secondary clock.

13. In a synchronizing system, the combination of a master clock, pneumatic means for creating impulses, a plurality of conduits, means to determine the distribution of said impulses over said conduits, a secondary clock, pneumatic means for driving said secondary clock, means intermediate said secondary clock and said conduits to selectively connect one of said conduits to said secondary clock, and means to actuate said last mentioned means at a predetermined time.

14. The combination set forth in claim 13 in which said last named means is controlled by the secondary clock.

15. In a synchronizing system, the combination of a master clock pneumatic means for creating impulses, two conduits, a valve mechanism for connecting either one of said conduits with said pneumatic means, a secondary clock, driving means, pneumatic means for actuating said driving means, another valve mechanism intermediate said last named pneumatic means and said conduits, and means for operating said last named valve mechanism to connect either one of said conduits with said last named pneumatic means.

16. The combination set forth in claim 15 in which said last mentioned means is controlled to operate at a predetermined time by said secondary clock.

17. A master clock for use in a synchronizing system, said clock comprising in combination, means controlled by said clock for creating recurring pressure impulses in fluids, a plurality of conduits containing

fluid, and means to selectively determine which of the pressure impulses will be transmitted to said fluid in said conduits.

18. The combination set forth in claim 17 in which said last named means is controlled by said clock.

19. A master clock for use in a synchronizing system, said clock comprising in combination, a plurality of conduits containing elastic fluid, means operated by said clock for alternately compressing and rarefying the fluid in said conduits, and means controlled by said clock to prevent said fluid from being compressed and rarefied in one of said conduits.

20. A master clock for use in a synchronizing system, said clock comprising in combination, a plurality of conduits containing elastic fluid, means operated by said clock for alternately compressing and rarefying the fluid in said conduits, and means controlled by said clock to determine which of said plurality of conduits will be affected by said first mentioned means.

21. A secondary clock for use in a synchronizing system, said clock comprising in combination, means for actuating the same, pneumatic means connected to said means, a plurality of conduits adapted to transmit fluid pressure, and means controlled by said clock for connecting one of said conduits with said pneumatic means.

22. A secondary clock for use in a synchronizing system, said clock comprising in combination, reciprocatory means for actuating the same, pneumatic means connected to said reciprocatory means, two conduits whereby pressure impulses are transmitted to said pneumatic means, and a valve means for connecting any one of said conduits with said pneumatic means during predetermined periods of time.

23. A pneumatic system for driving a secondary clock, comprising, in combination, a plurality of conduits, a master clock having connections with said conduits and means controlling variations in pressure in said conduits, valves for rendering certain of said variations in pressure ineffectual, and a secondary clock having connections with said conduits enabling the secondary clock to be driven by variations in pressure in both of said conduits.

24. A pneumatic system for driving a secondary clock and for maintaining said secondary clock in synchronism with a master clock, comprising, in combination, a plurality of conduits, a master clock having connections with said conduits and means controlling variations in pressure in said conduits, valves for rendering certain of said variations in pressure ineffectual, and a secondary clock having connections with said conduits enabling the secondary clock to be controlled and maintained in synchronism with said

master clock by variations in pressure in both of said conduits.

25. A master clock for use in a synchronizing clock system comprising, in combination, pneumatic bellows repeatedly actuated
5 by the master clock, a pair of conduits having connection with said pneumatic bellows, and means controlled by the master clock for determining which impulses of fluid pressure created by said bellows are to be sent over
10 one or both of said conduits.

26. A synchronizing clock system comprising, in combination, a master clock, means controlled by said master clock for creating
15 recurring fluid pressure impulses, a plurality of conduits adapted to transmit fluid pressure from said means, a secondary clock, said secondary clock having a driving mechanism therefor connected so as to receive fluid pressure impulses from said means and through
20 each of said conduits, and means to determine the utilization of said fluid pressure impulses by said secondary clock mechanism for controlling the operation of said secondary clock.

In testimony whereof I hereto affix my
25 signature.

JAMES W. BRYCE.

30

35

40

45

50

55

60

6