



(19) **United States**

(12) **Patent Application Publication**  
**Zavadsky et al.**

(10) **Pub. No.: US 2014/0146797 A1**

(43) **Pub. Date: May 29, 2014**

(54) **TIMESLOT MAPPING AND/OR  
AGGREGATION ELEMENT FOR DIGITAL  
RADIO FREQUENCY TRANSPORT  
ARCHITECTURE**

**Publication Classification**

(51) **Int. Cl.**  
**H04L 5/00** (2006.01)  
**H04W 72/12** (2006.01)  
(52) **U.S. Cl.**  
CPC ..... **H04L 5/0085** (2013.01); **H04W 72/12**  
(2013.01)  
USPC ..... **370/336**

(71) Applicant: **ADC Telecommunications, Inc.**,  
Shakopee, MN (US)

(72) Inventors: **Dean Zavadsky**, Shakopee, MN (US);  
**Jody Forland**, St. Bonifacius, MN (US);  
**Larry G. Fischer**, Waseca, MN (US);  
**Philip M. Wala**, Savage, MN (US)

(73) Assignee: **ADC Telecommunications, Inc.**,  
Shakopee, MN (US)

(21) Appl. No.: **14/090,135**

(22) Filed: **Nov. 26, 2013**

**Related U.S. Application Data**

(60) Provisional application No. 61/729,789, filed on Nov. 26, 2012.

(57) **ABSTRACT**

A serial link interface unit includes serialized data stream interfaces configured to receive a serialized data stream having a data rate and set of timeslots; an aggregate serialized data stream interface configured to communicate an aggregate serialized data stream having aggregate data rate and plurality of aggregate timeslot sets each coming sequentially in time, wherein a second aggregate timeslot set comes after a first aggregate timeslot set; and wherein the serial link interface unit interleaves data from the different serialized data streams received at the plurality of first interfaces by mapping data from a first timeslot from each different serialized data stream to the first aggregate timeslot set in the aggregate serialized data stream and mapping data from a second timeslot from each different serialized data stream to the second aggregate timeslot set in the aggregate serialized data stream.

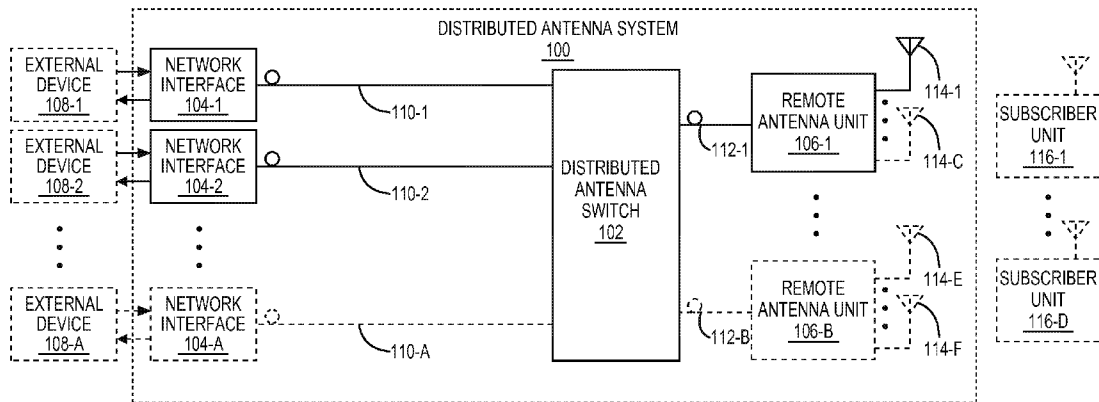

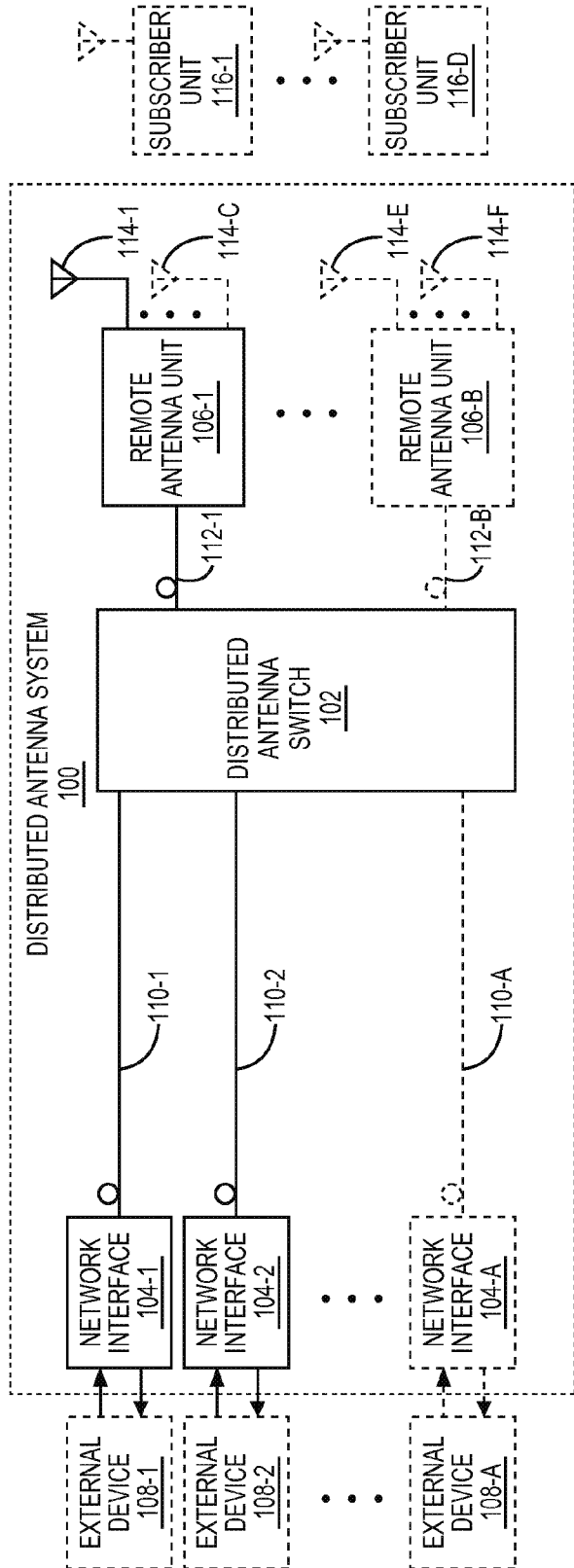

FIG. 1

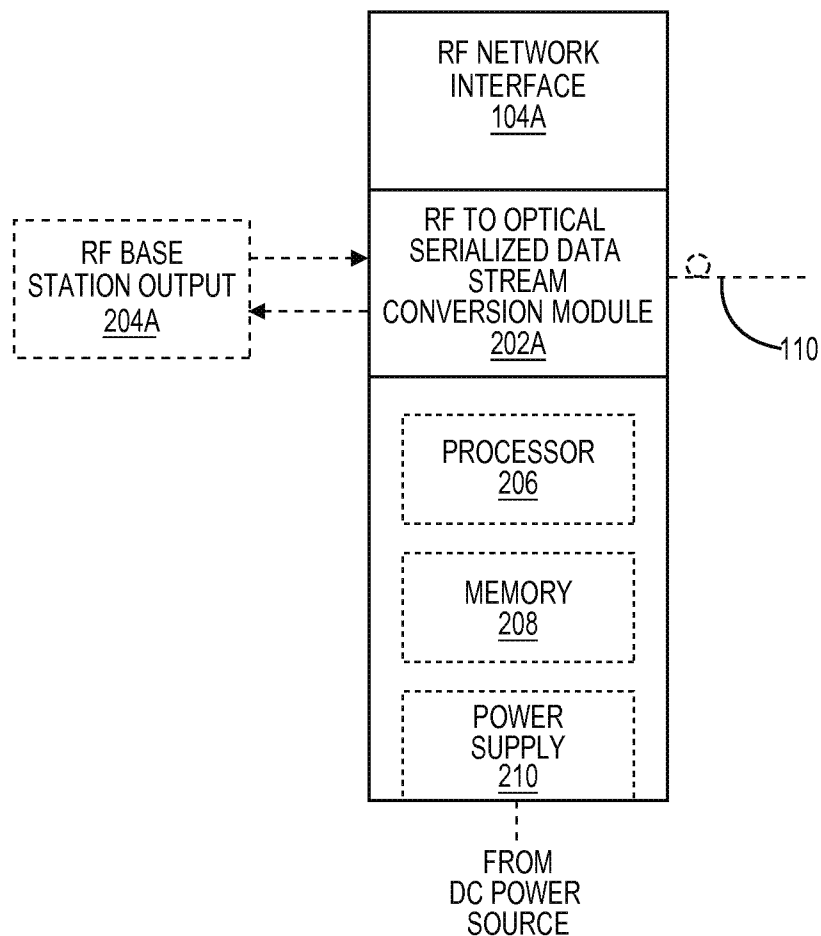

FIG. 2A

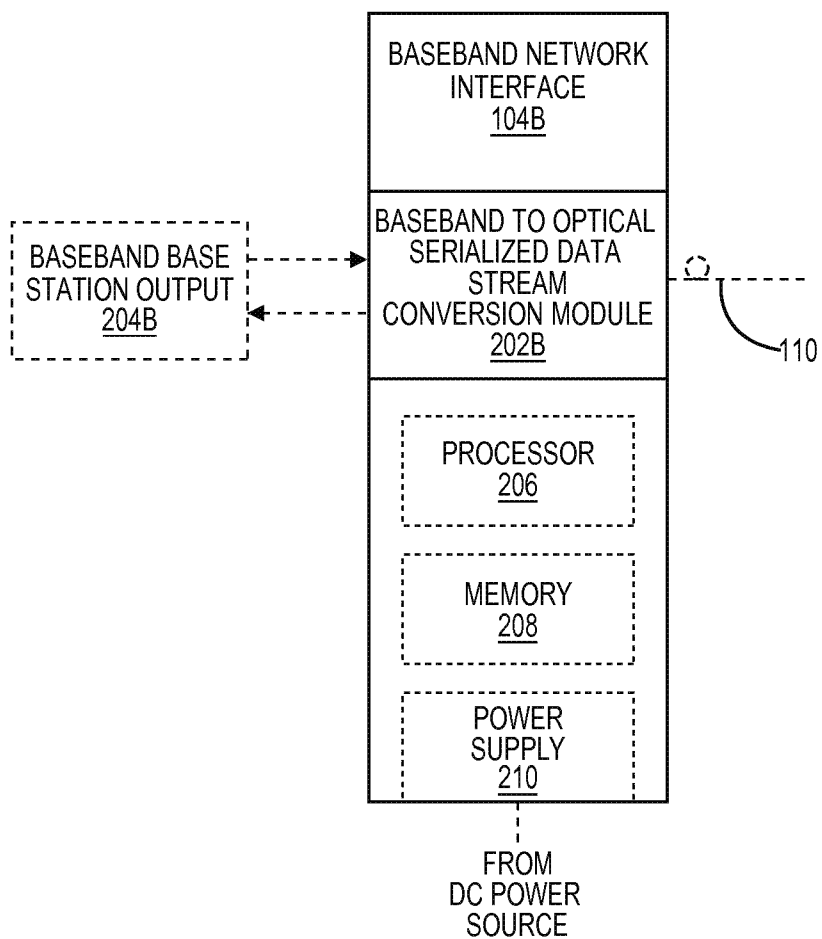

FIG. 2B

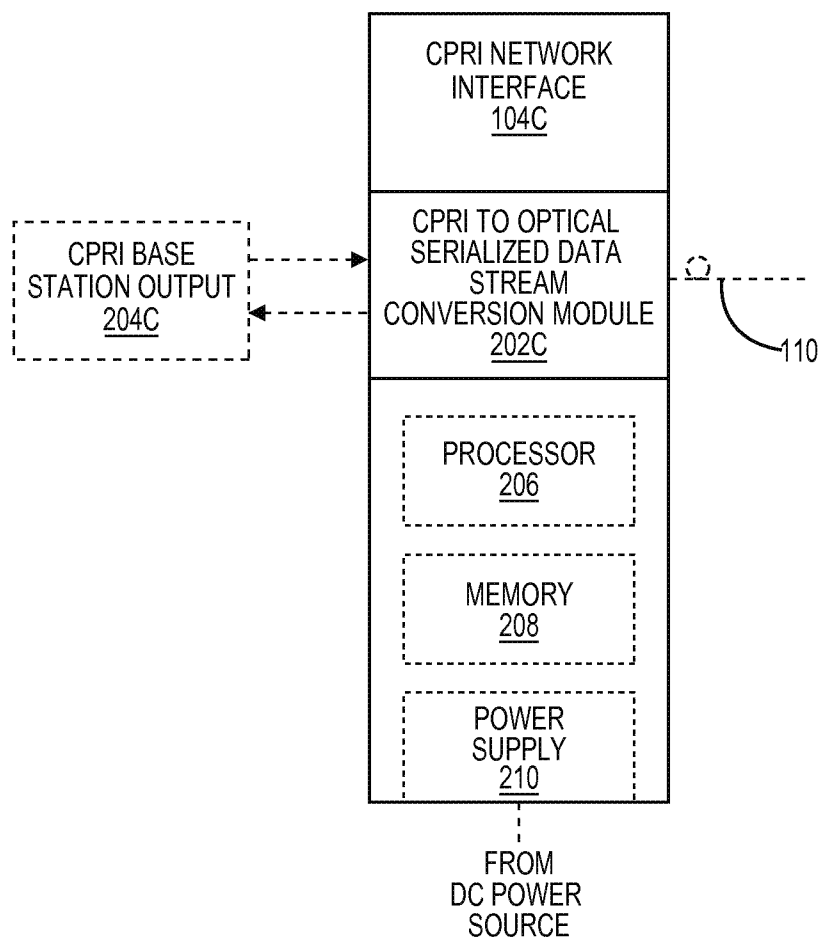

FIG. 2C

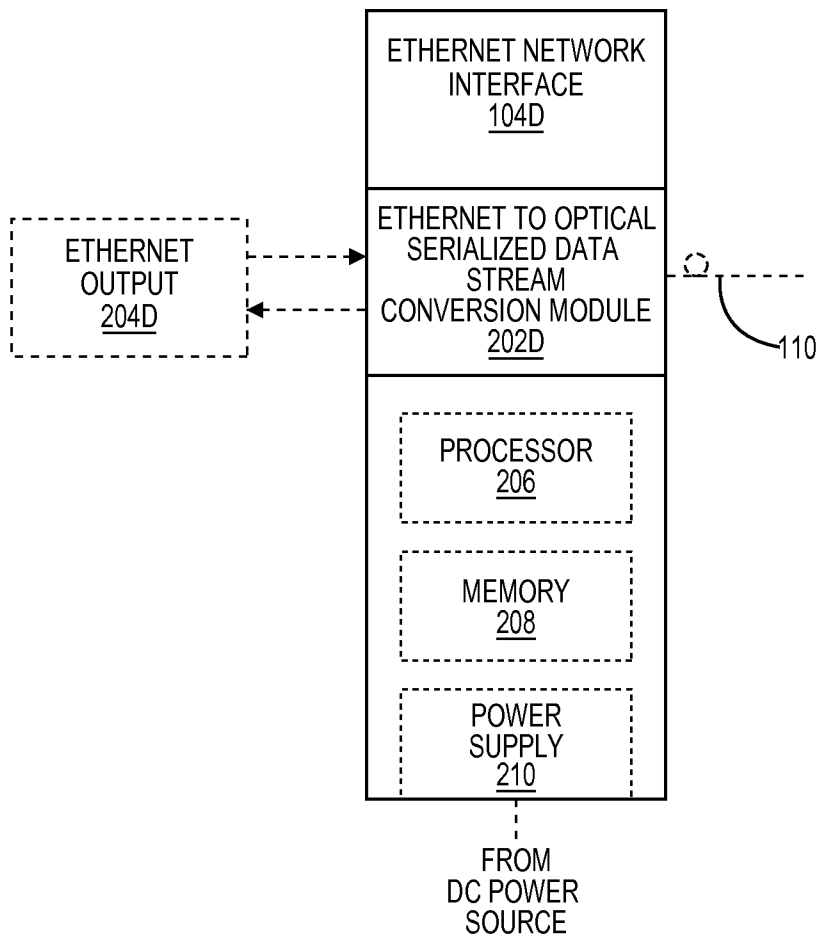

FIG. 2D

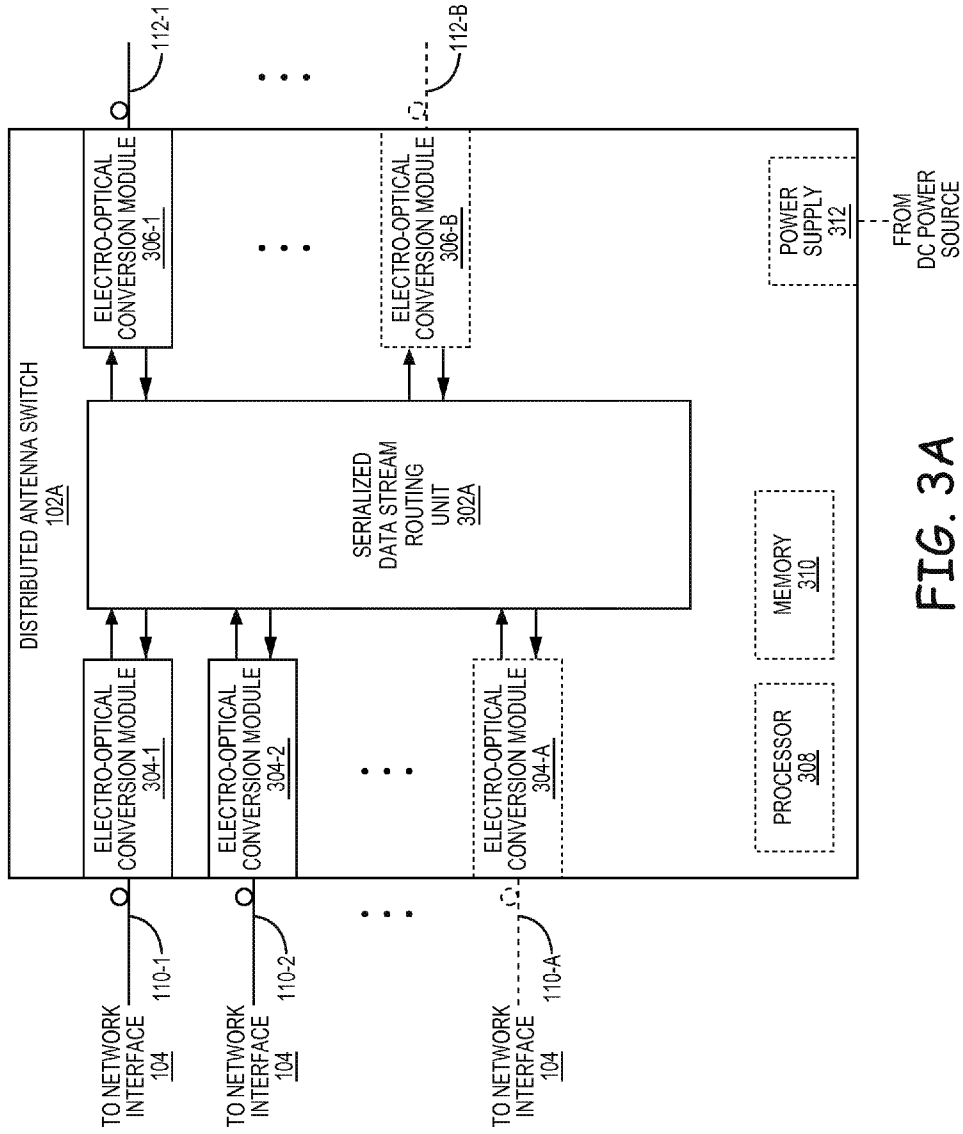

FIG. 3A

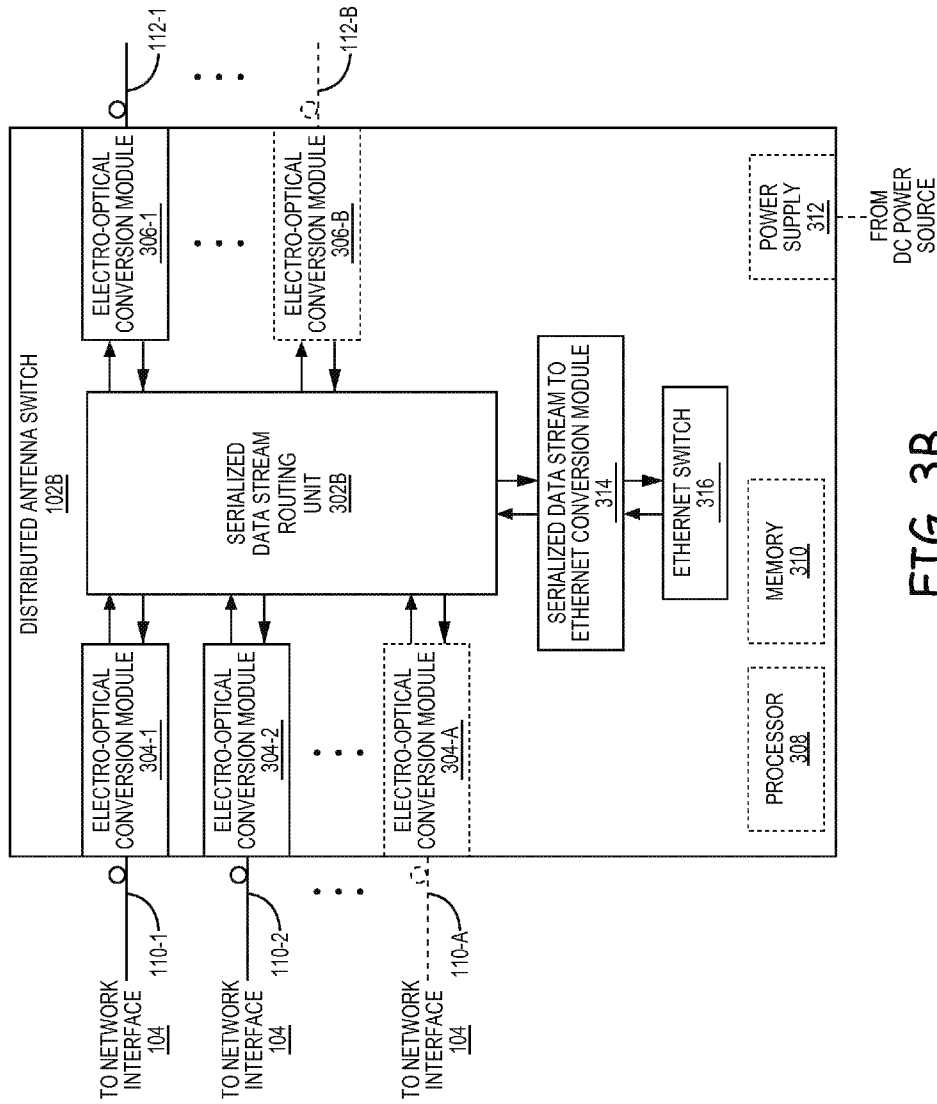

FIG. 3B



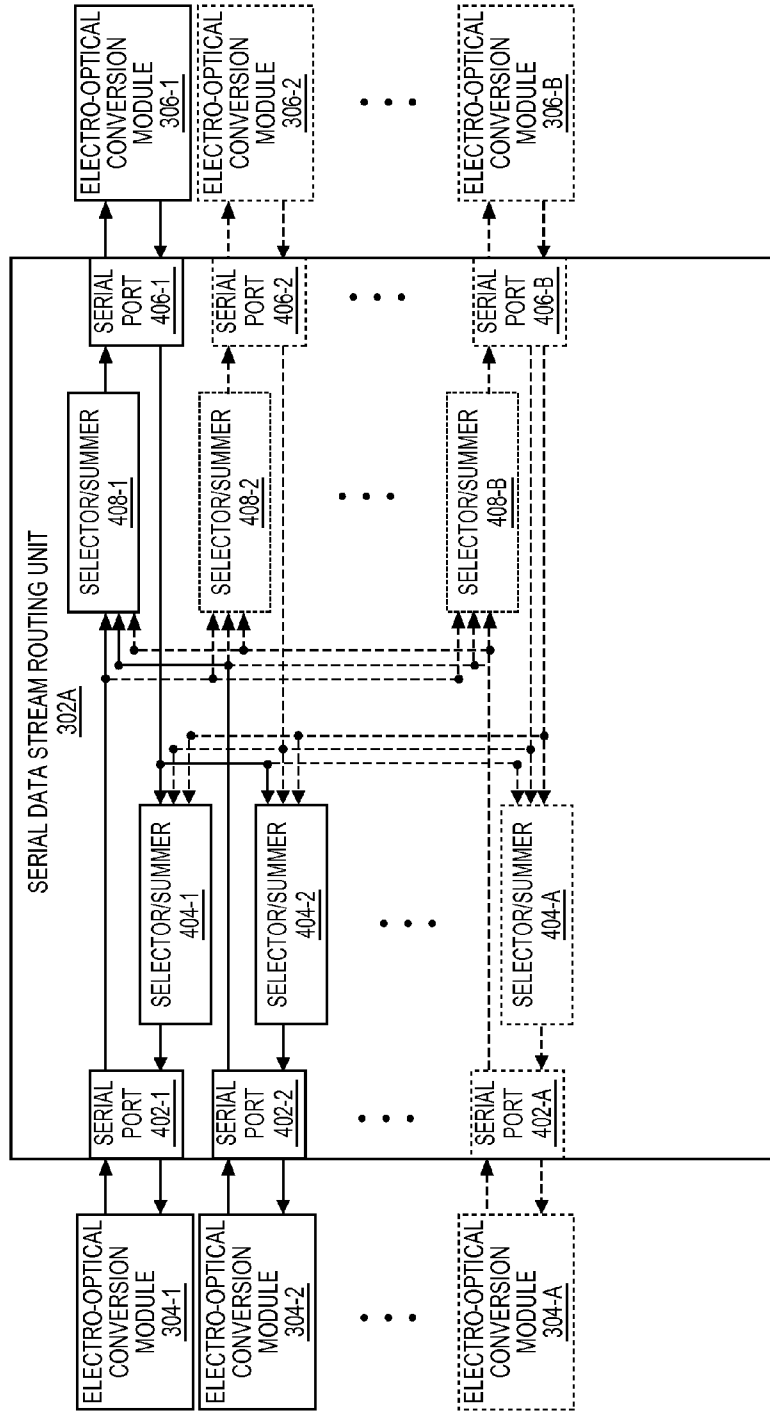

FIG. 4A

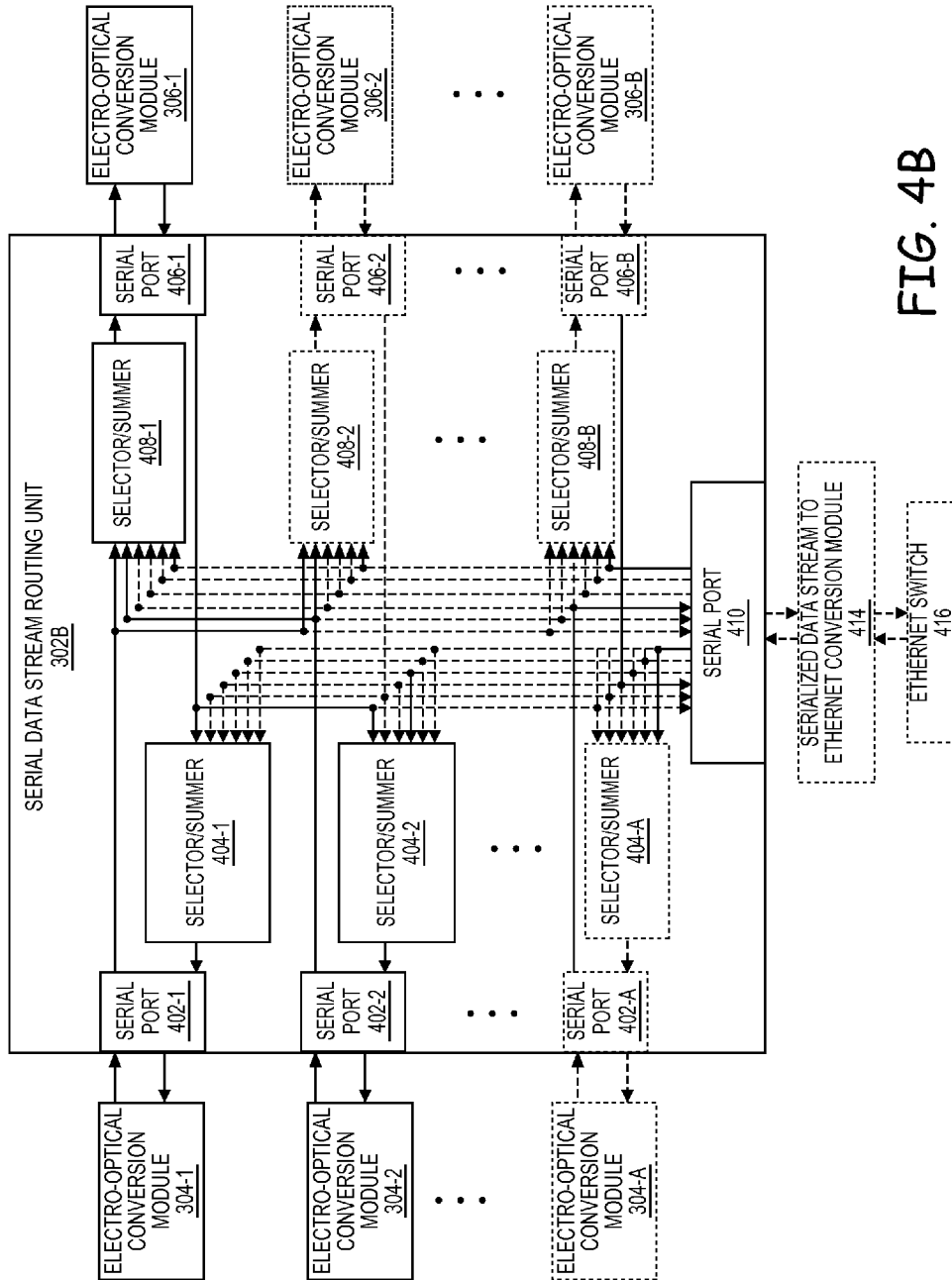

FIG. 4B

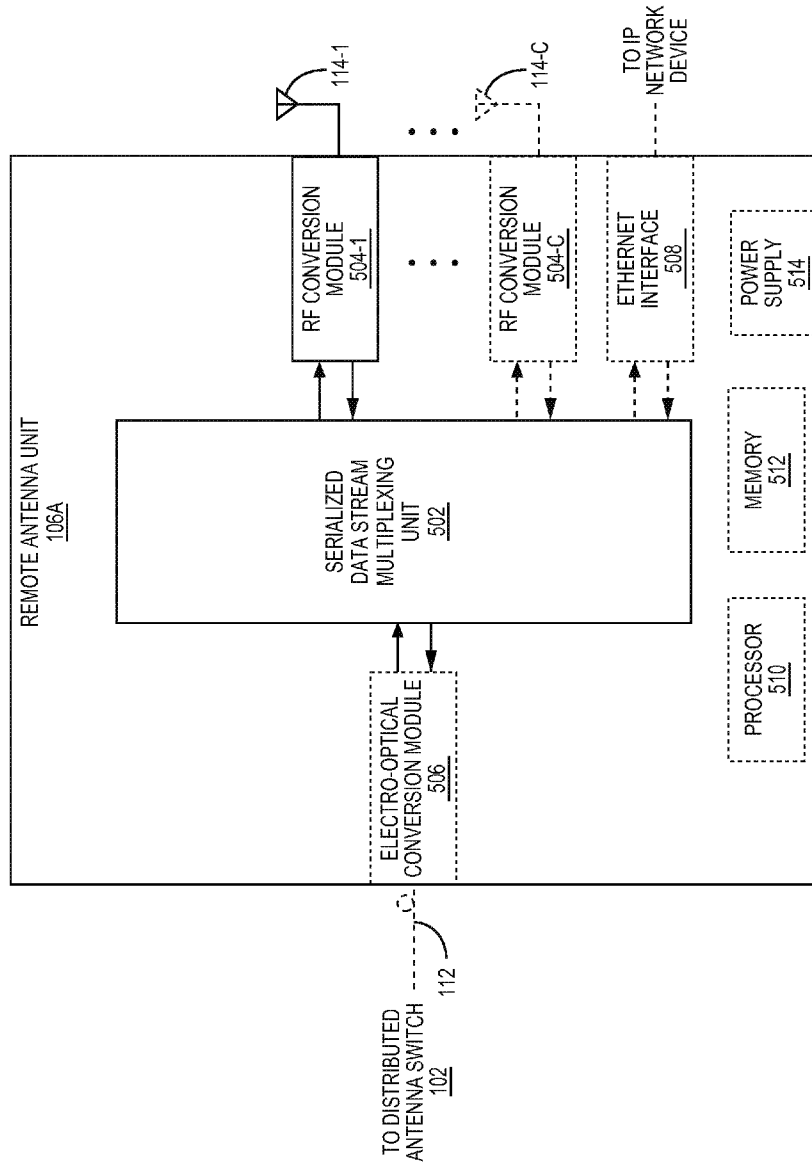

FIG. 5A

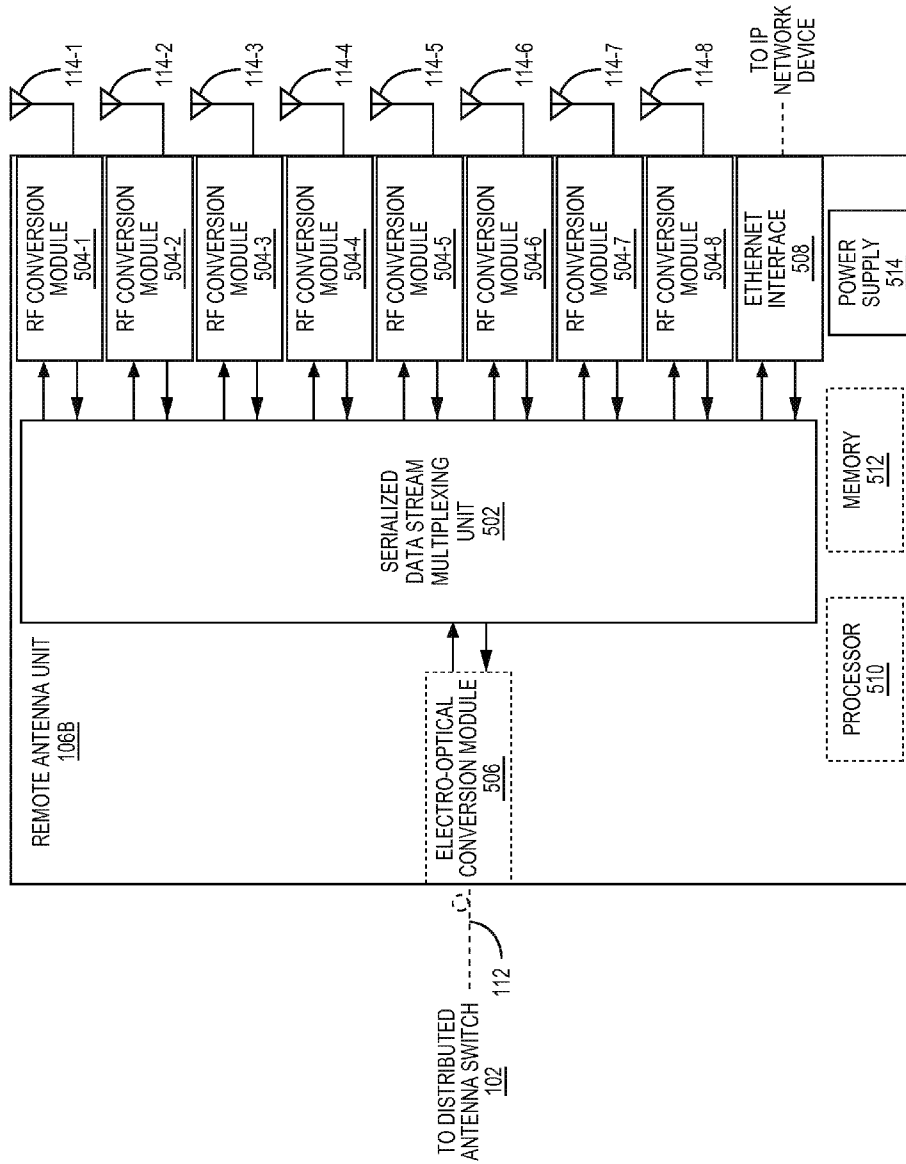

FIG. 5B

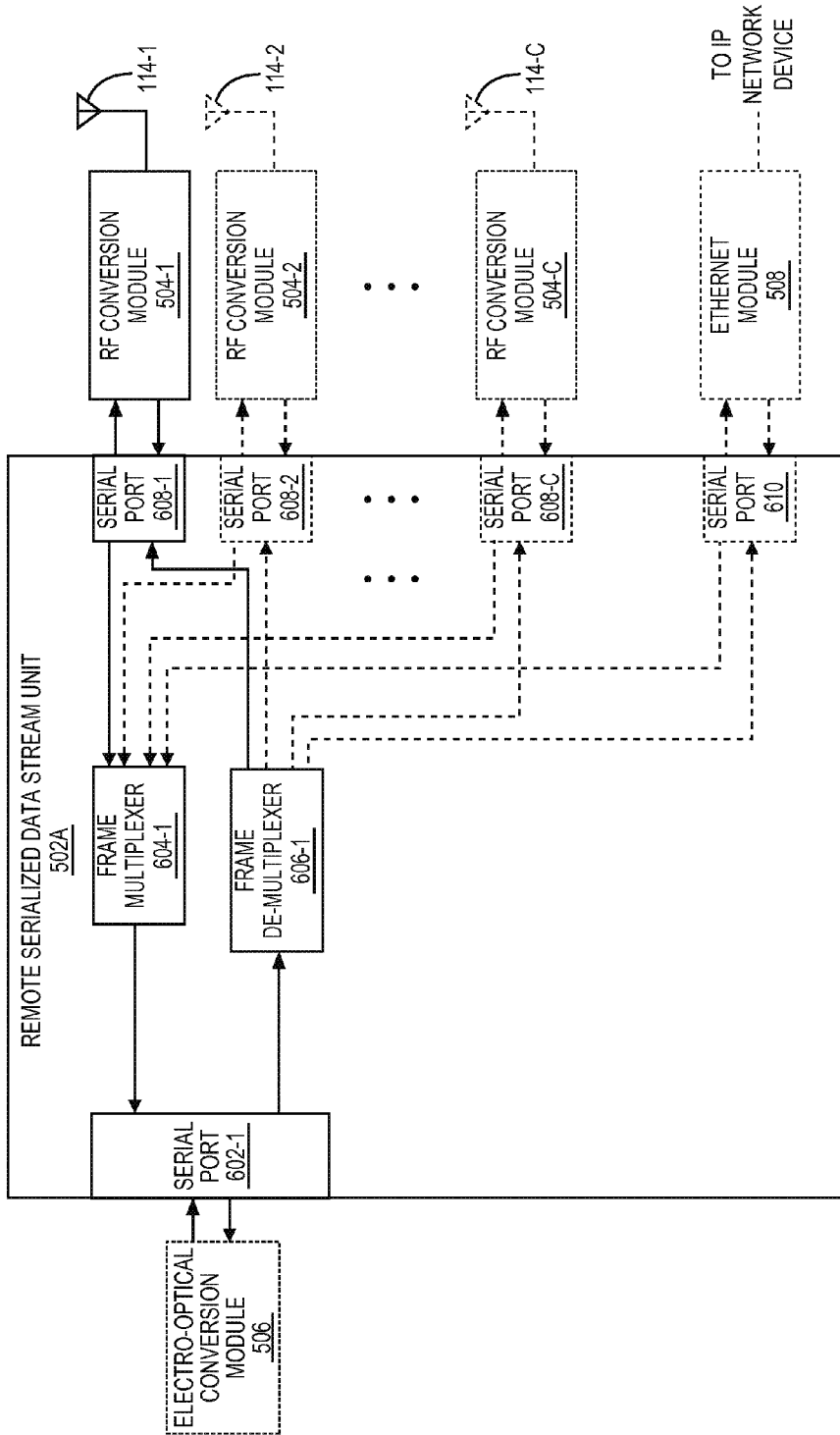

FIG. 6A

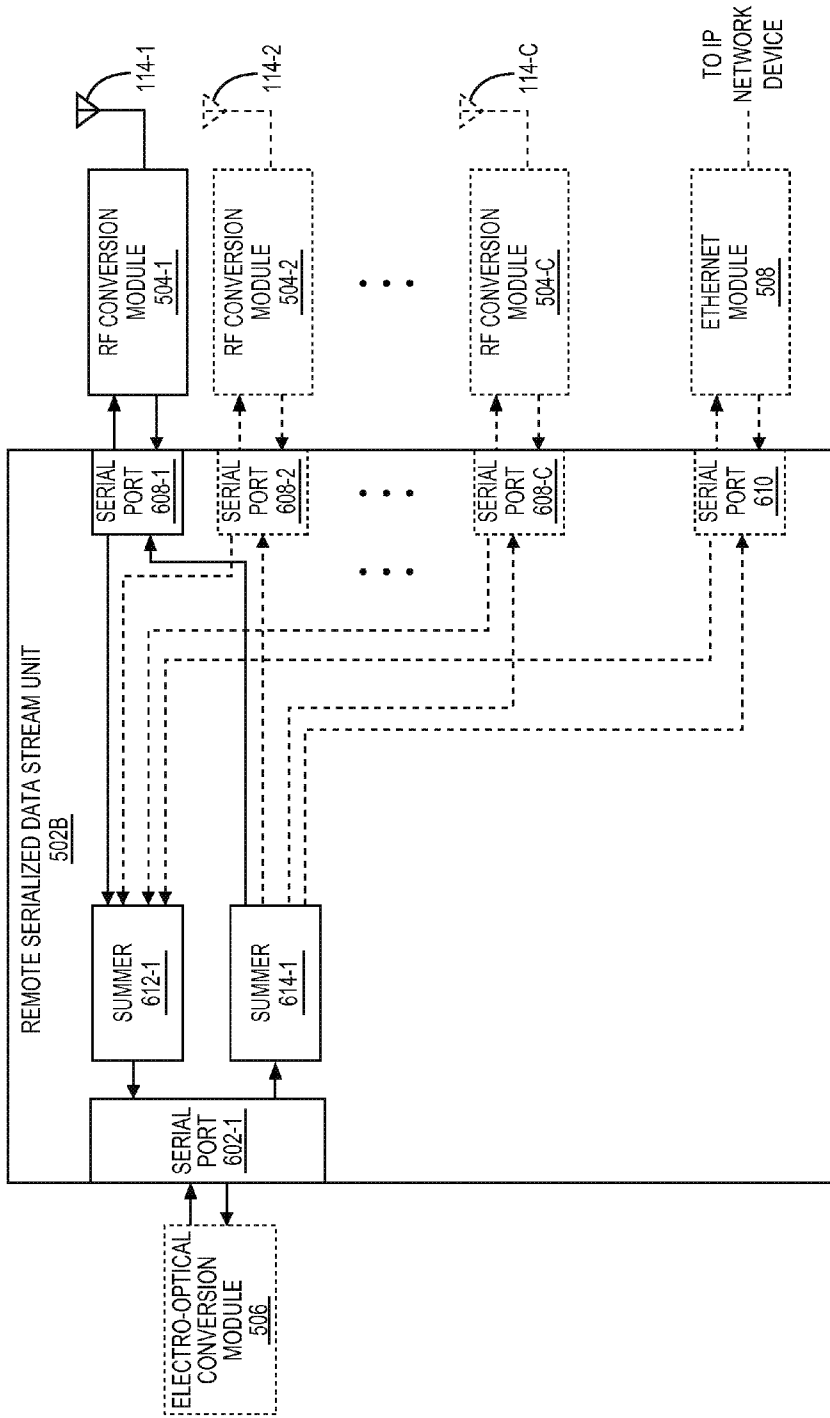

FIG. 6B

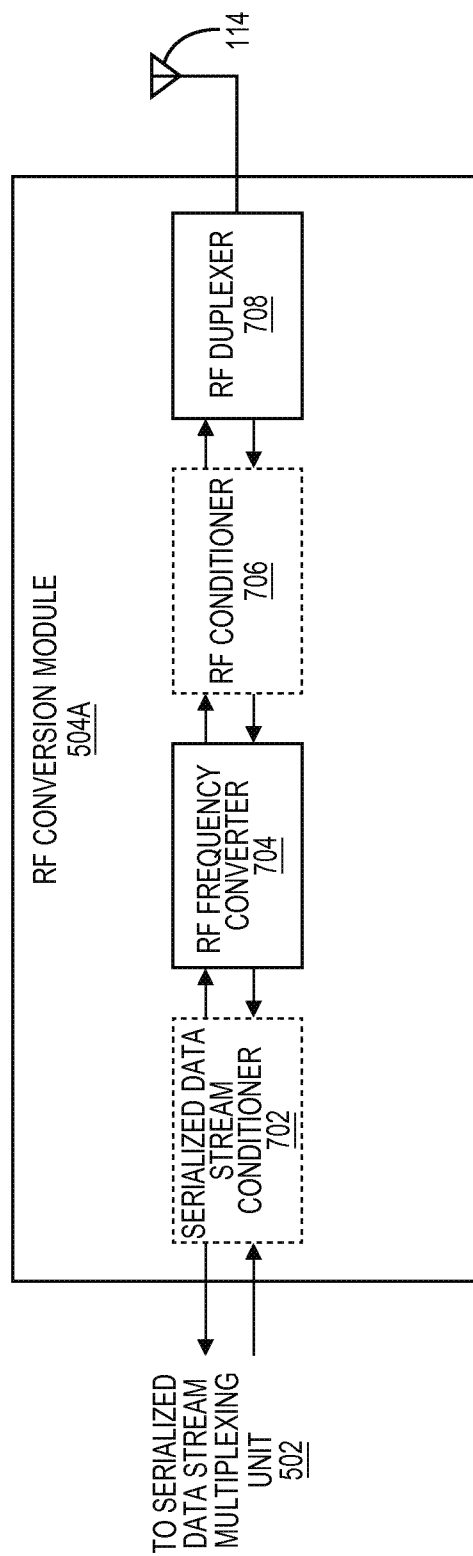

FIG. 7A

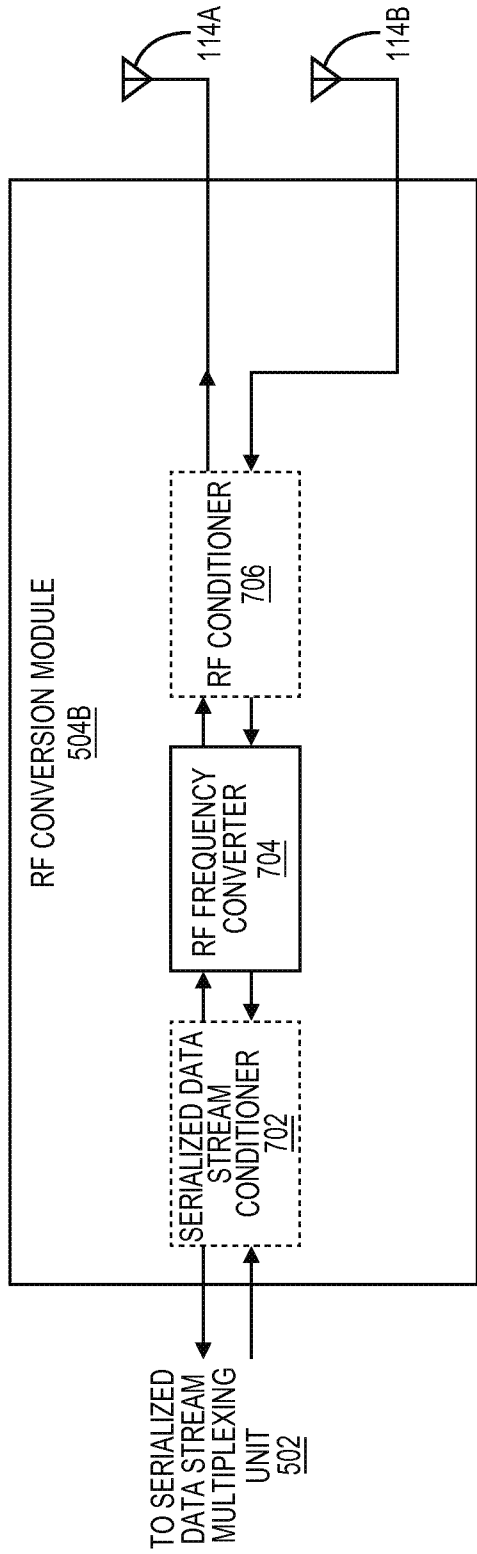

FIG. 7B



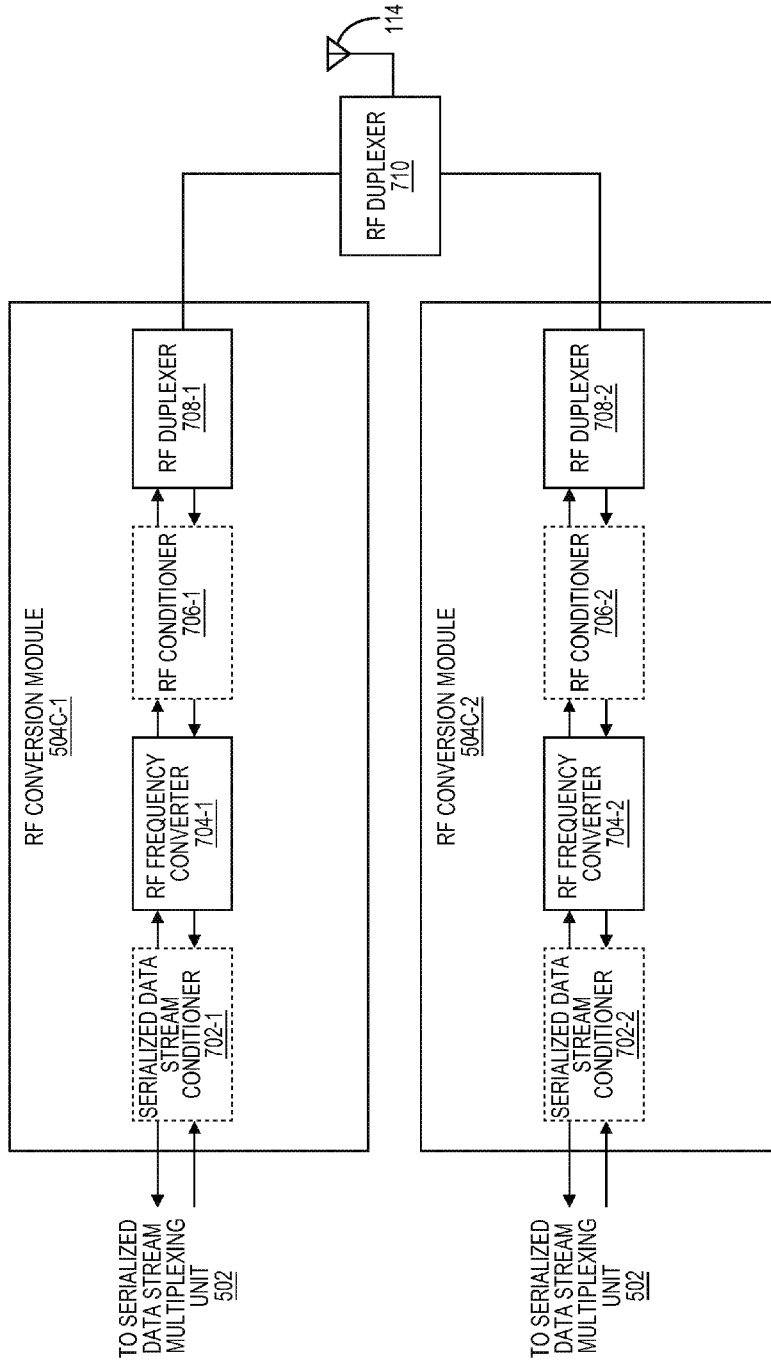

FIG. 7C

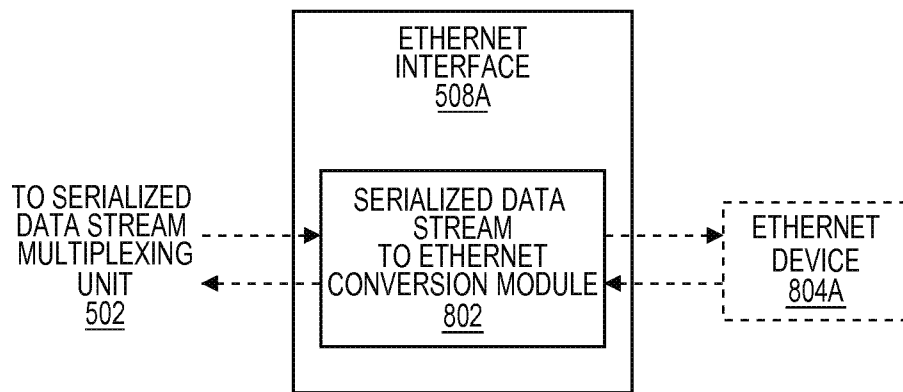

FIG. 8A

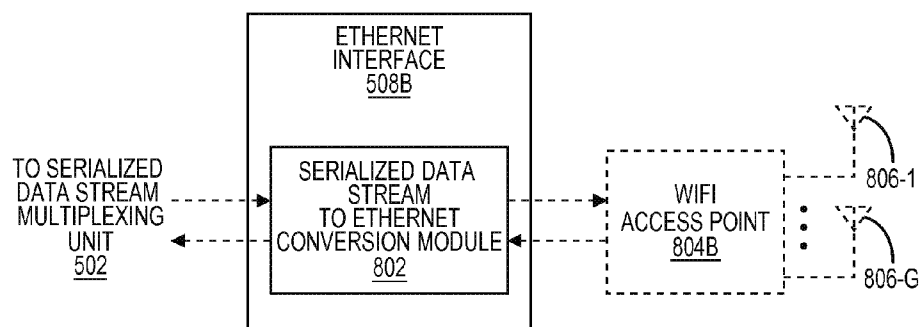

FIG. 8B

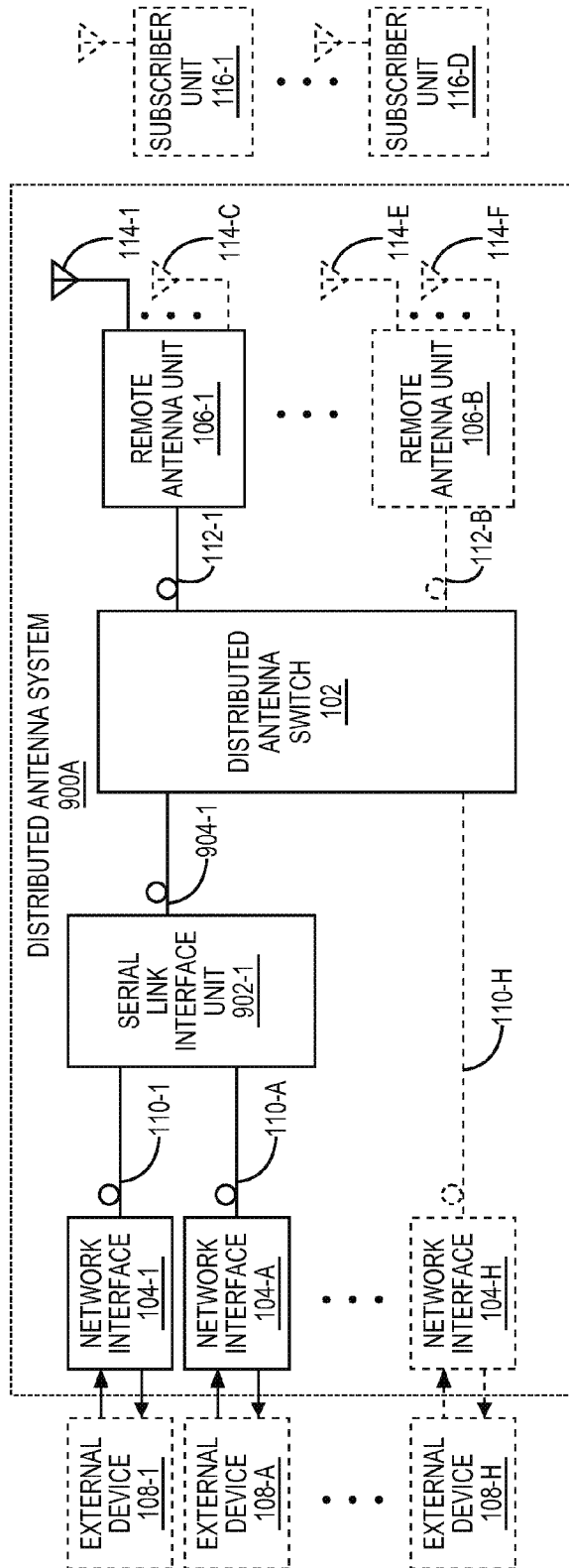

FIG. 9A

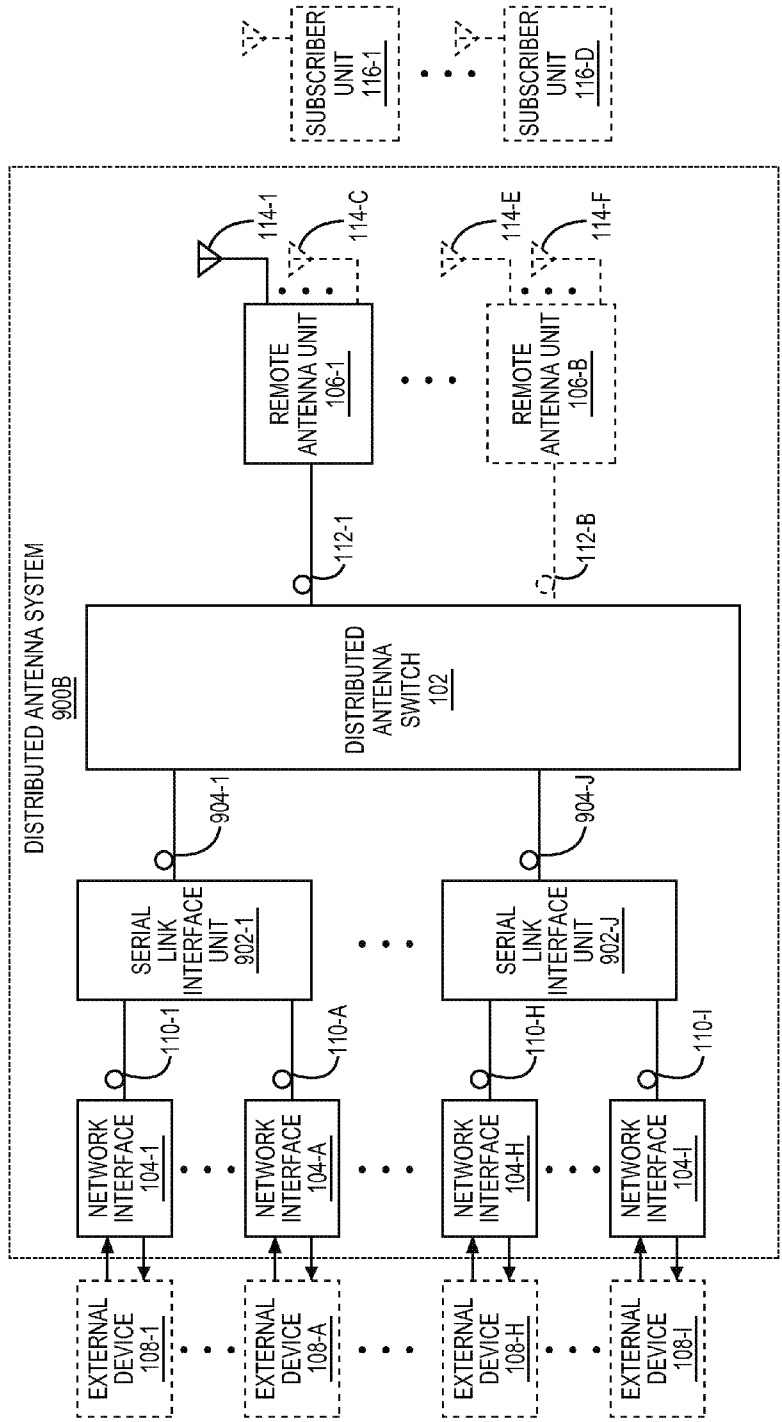

FIG. 9B

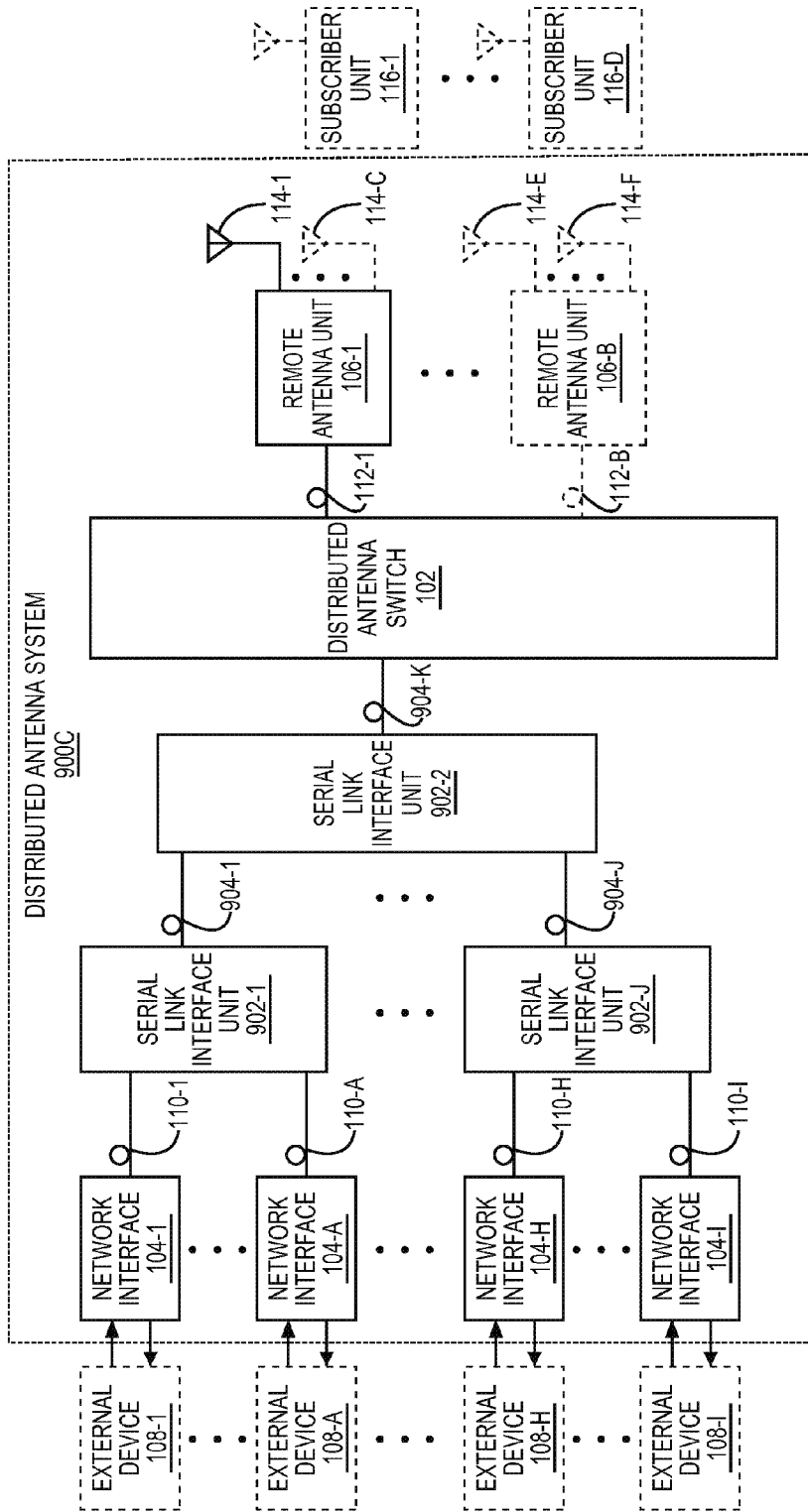

FIG. 9C

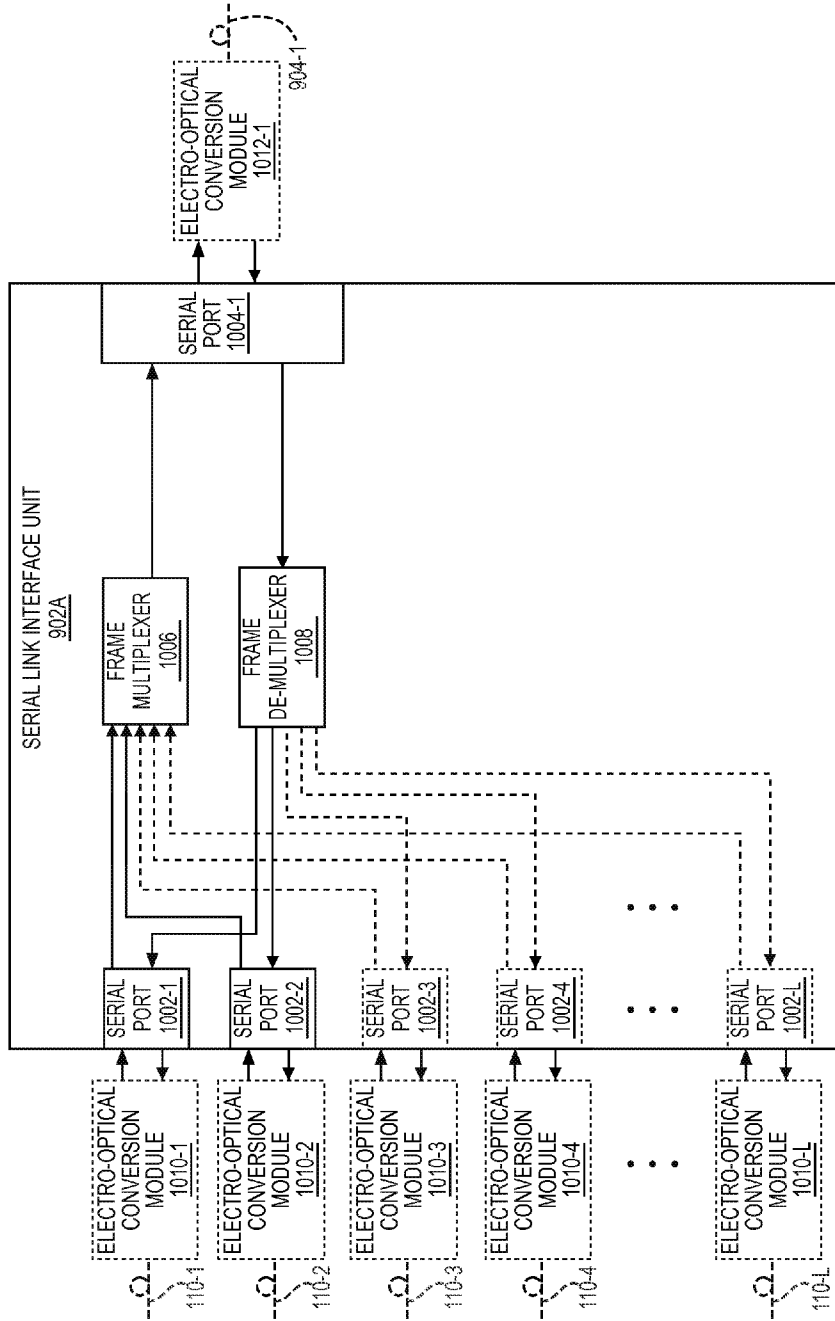

FIG. 10A

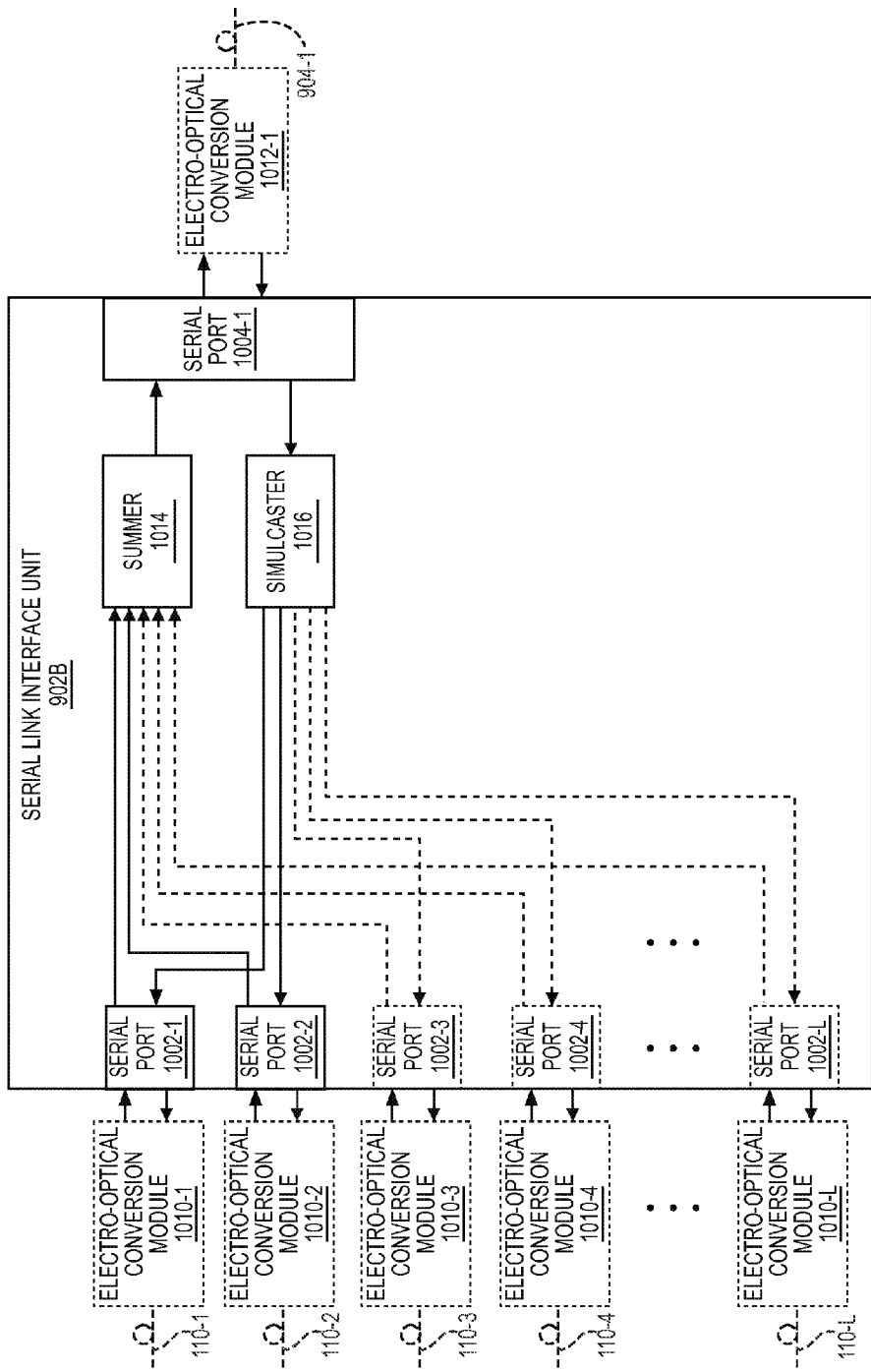

FIG. 10B



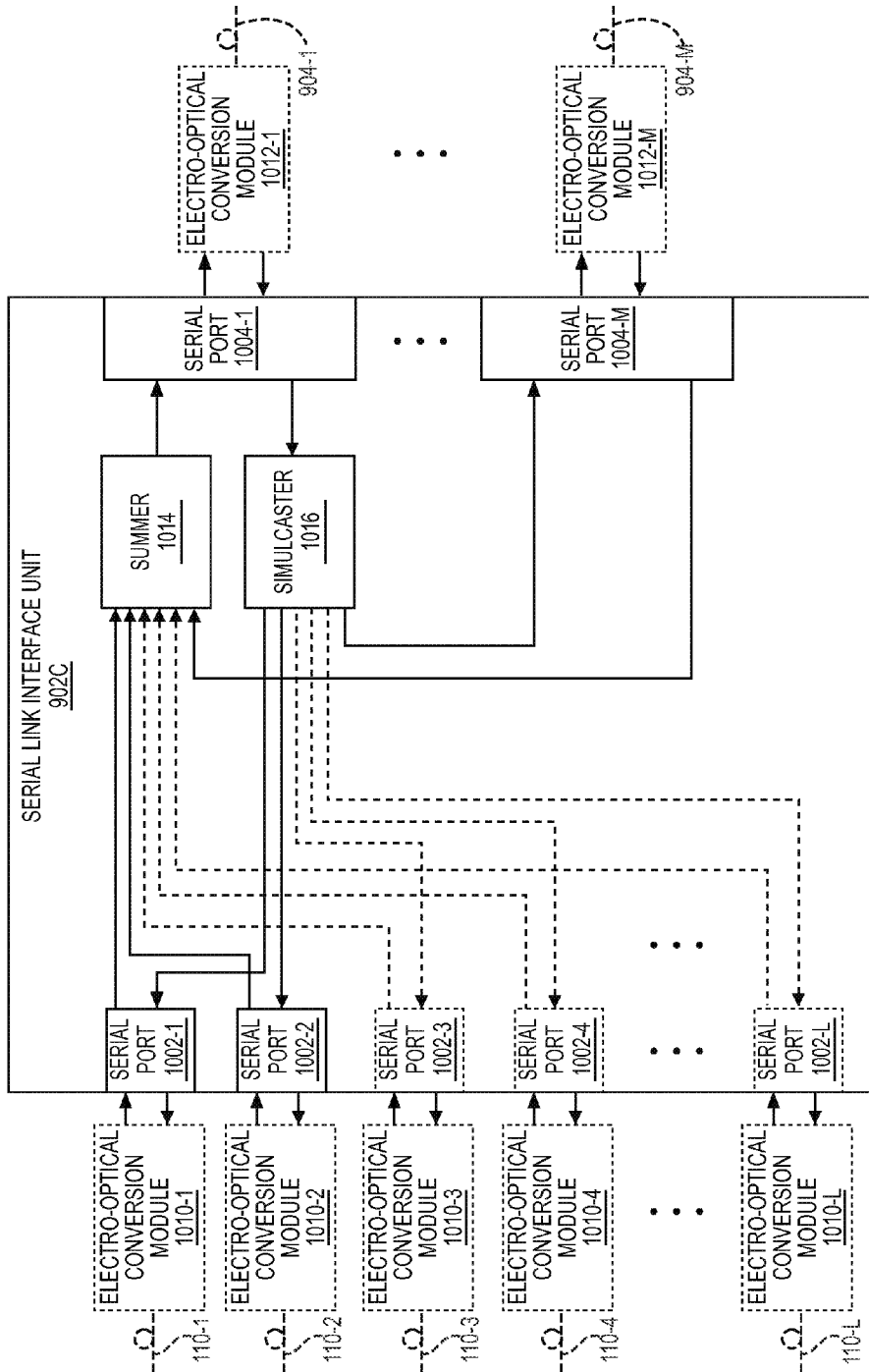

FIG. 10C

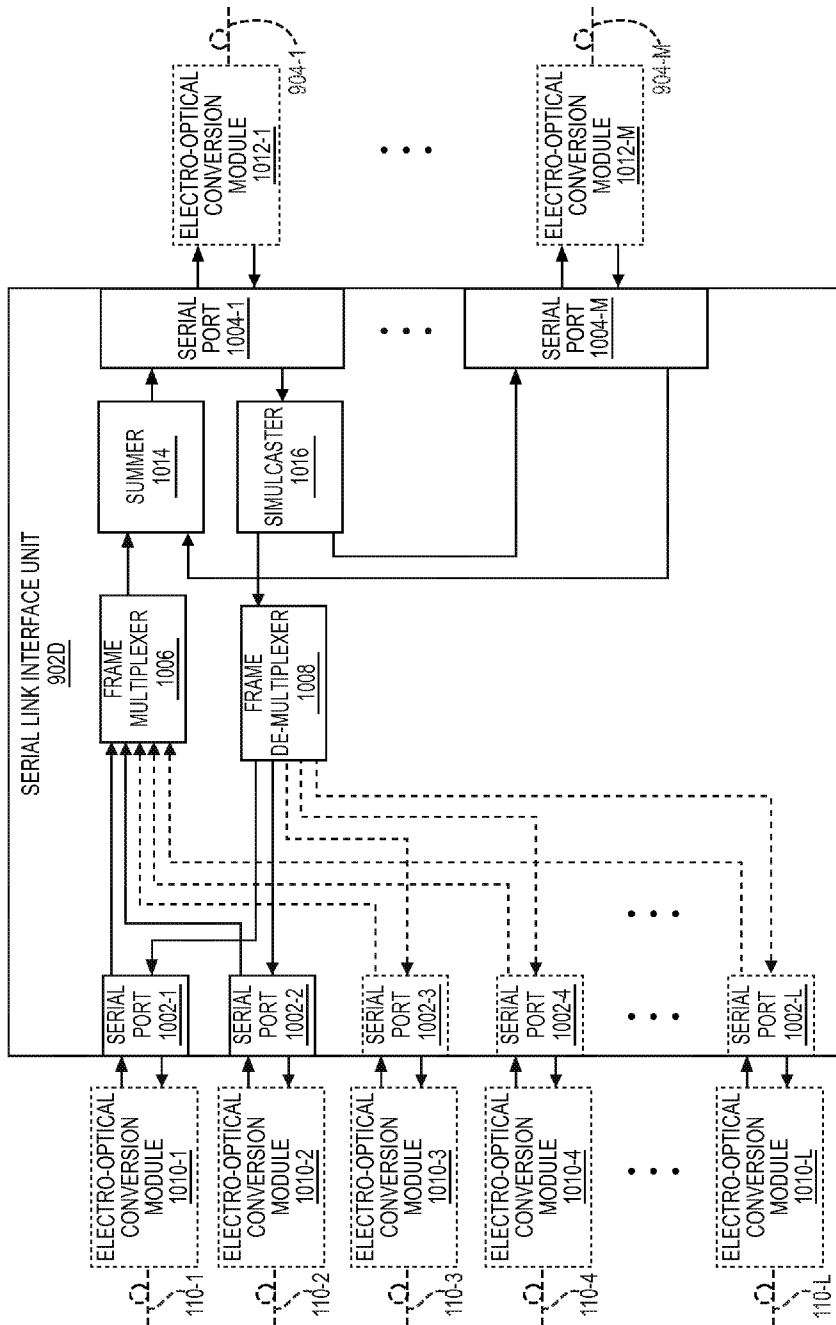

FIG. 10D

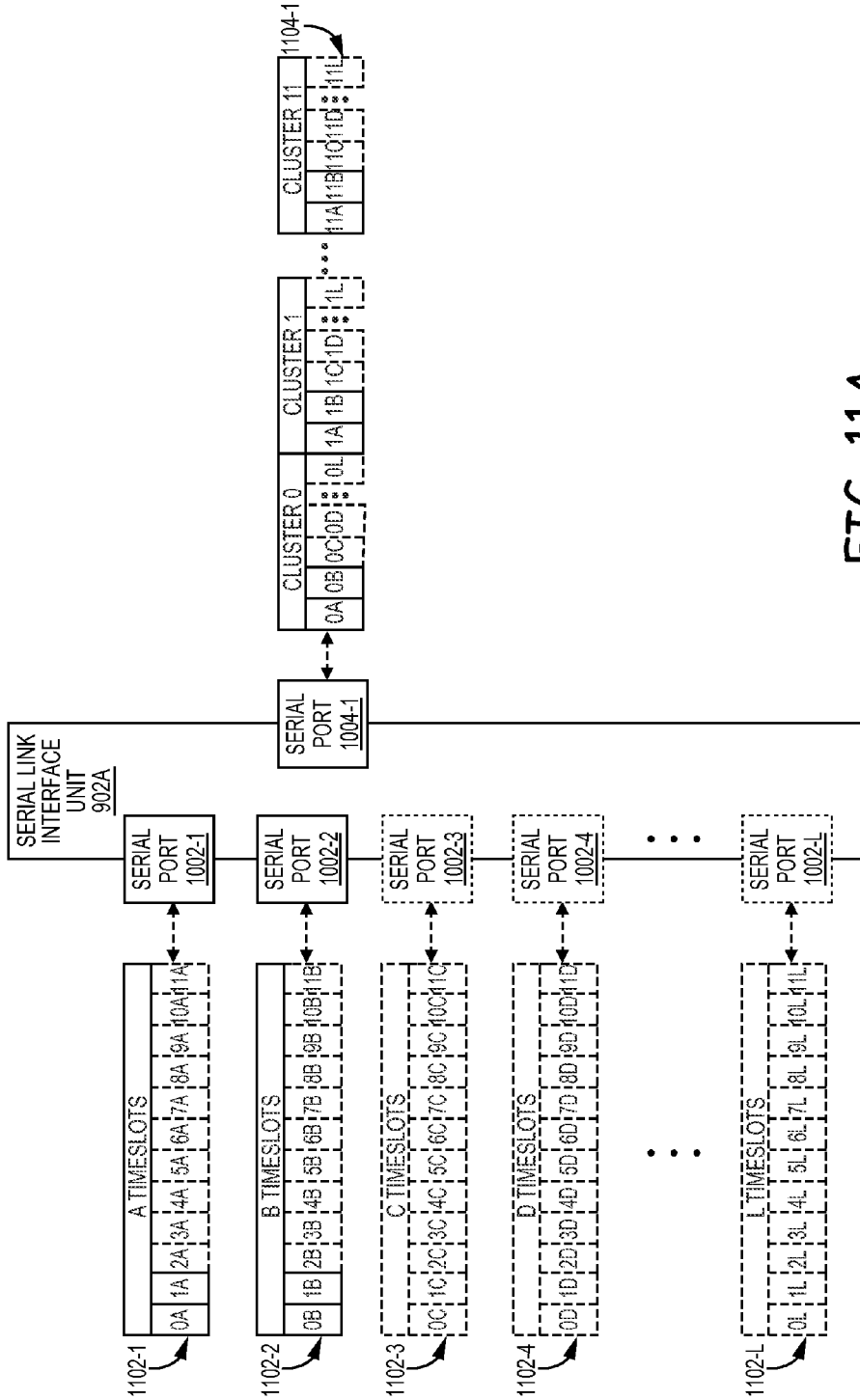

FIG. 11A

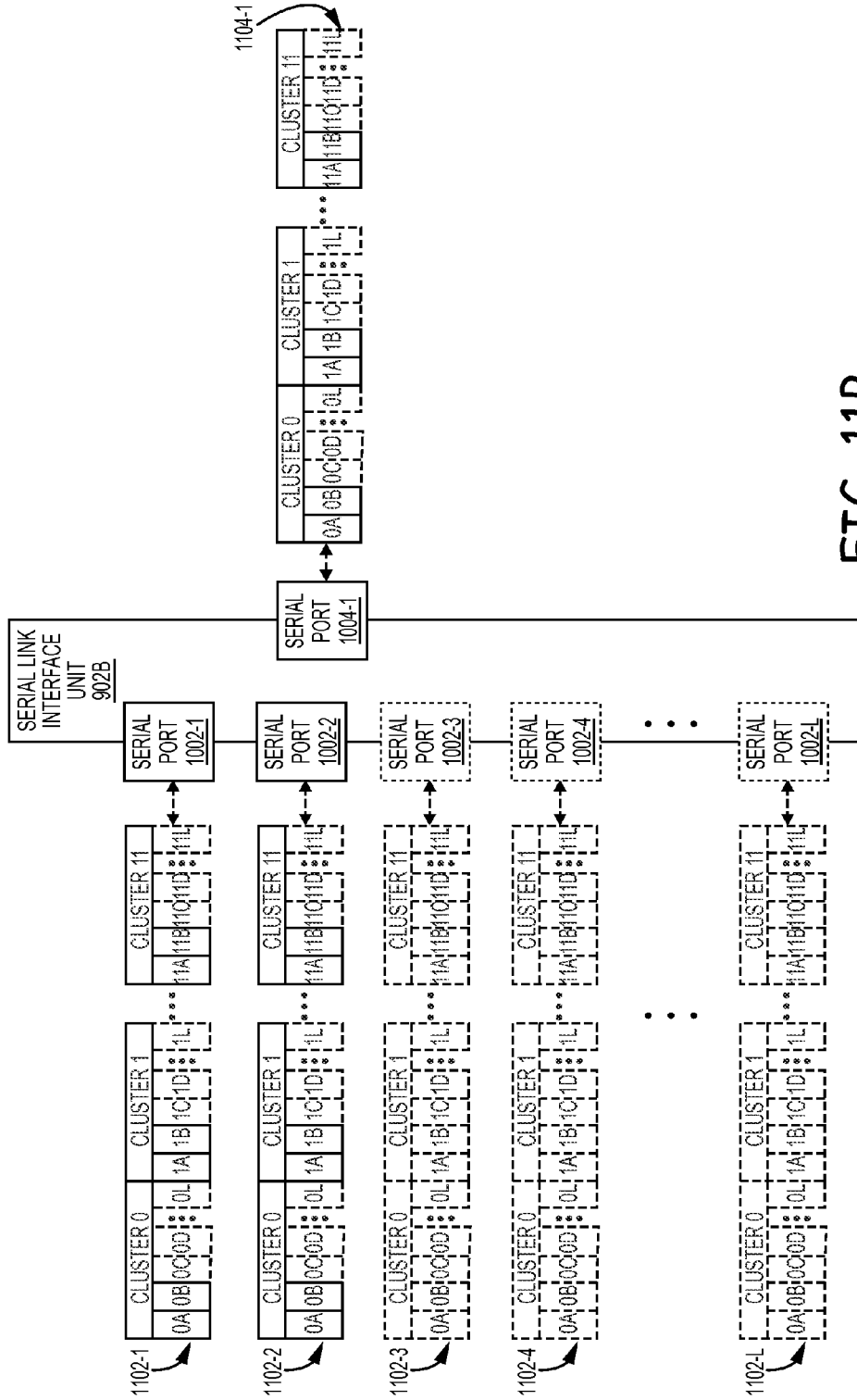

FIG. 11B

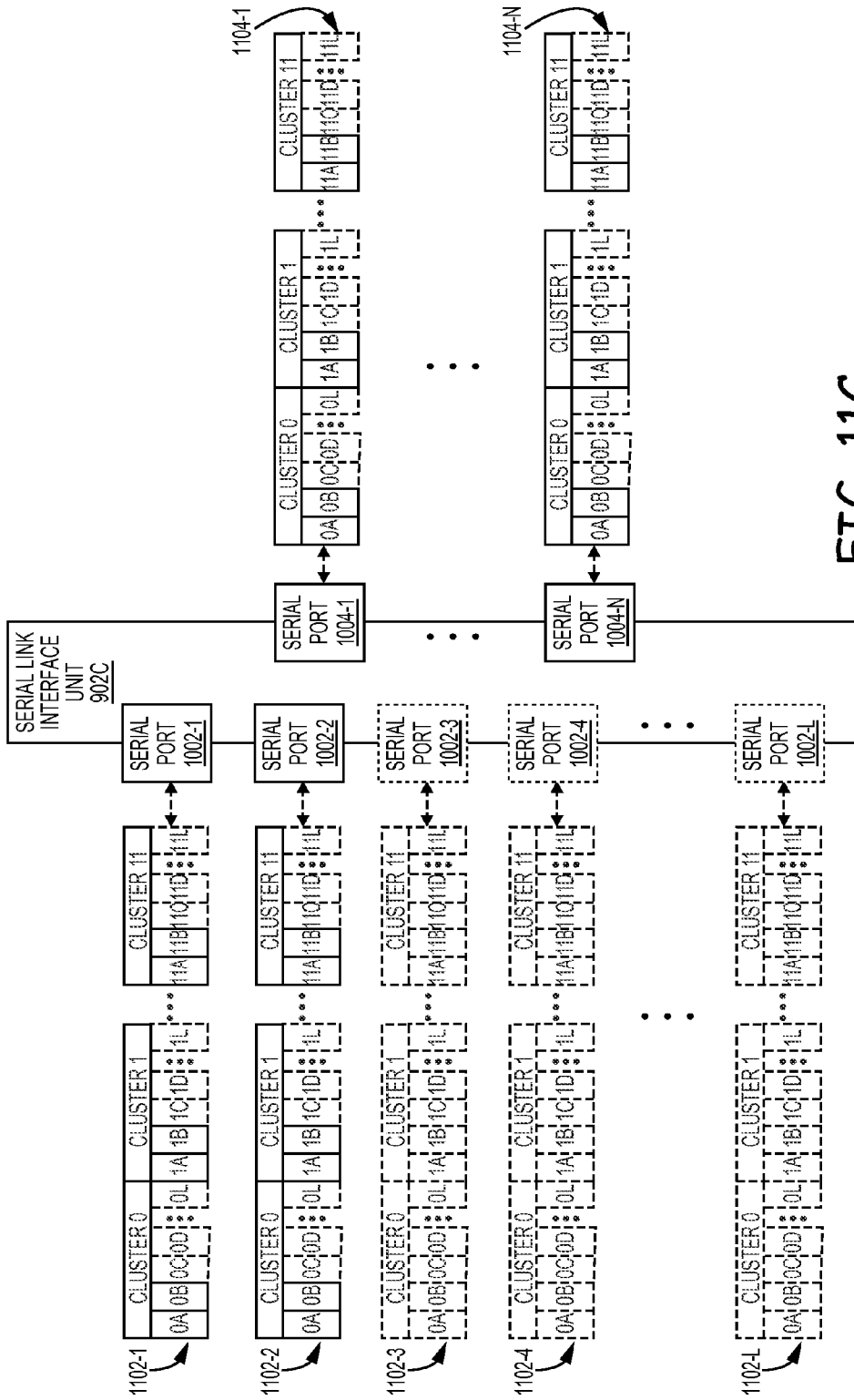

FIG. 11C

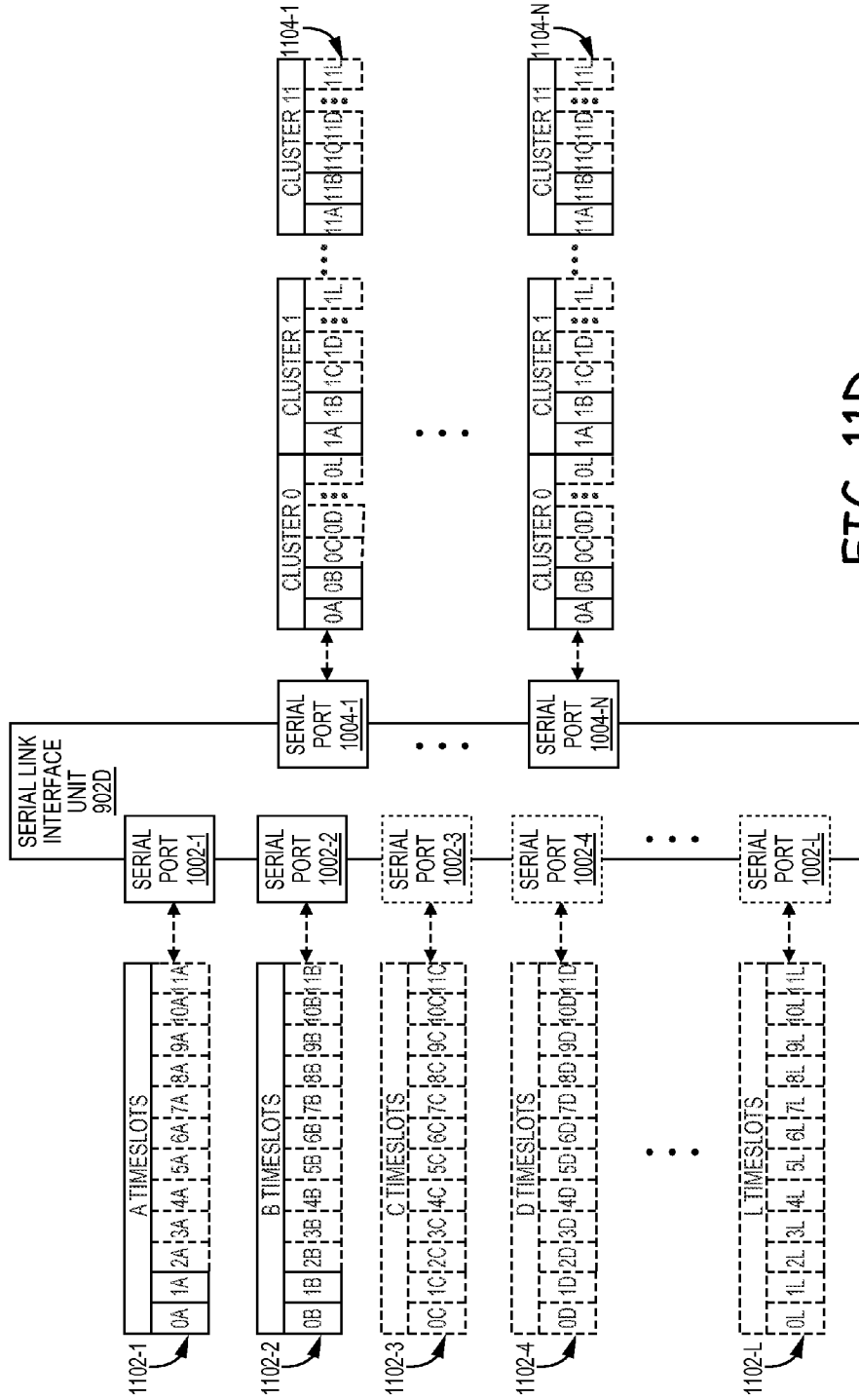

FIG. 11D

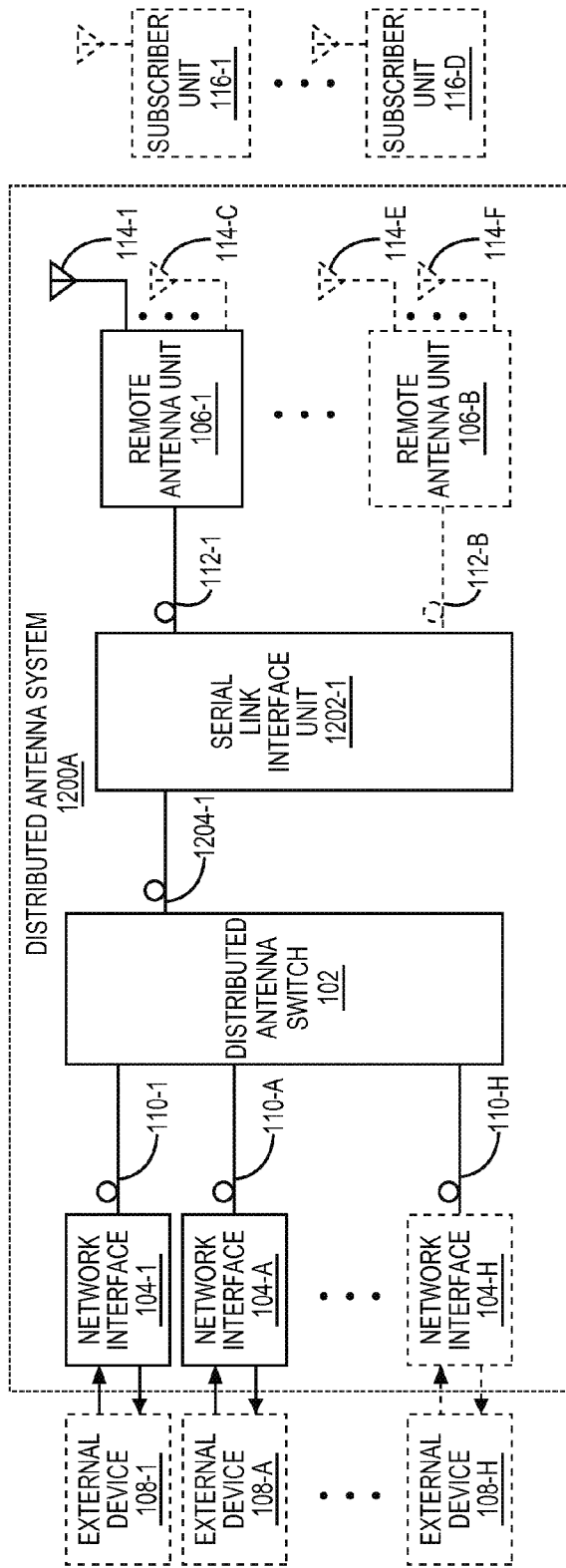

FIG. 12A

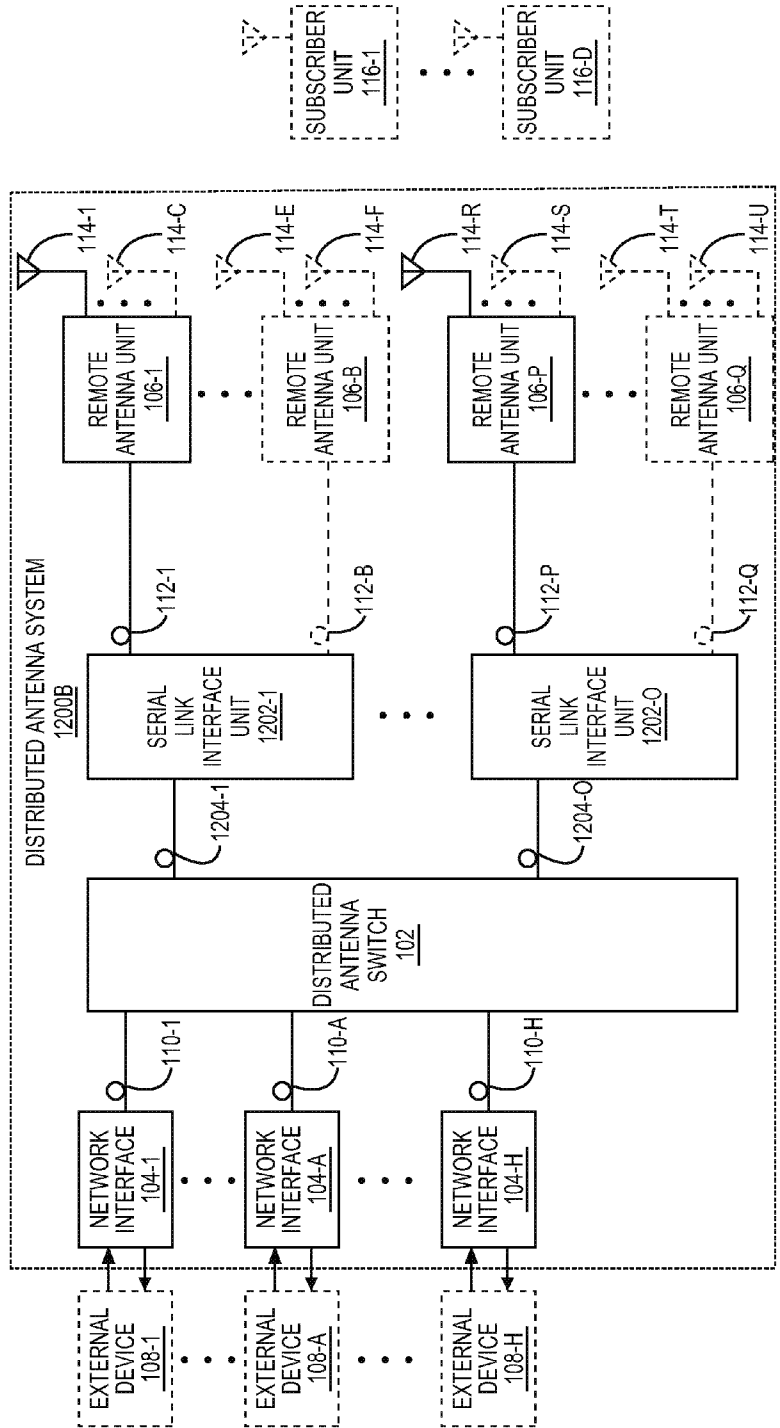

FIG. 12B



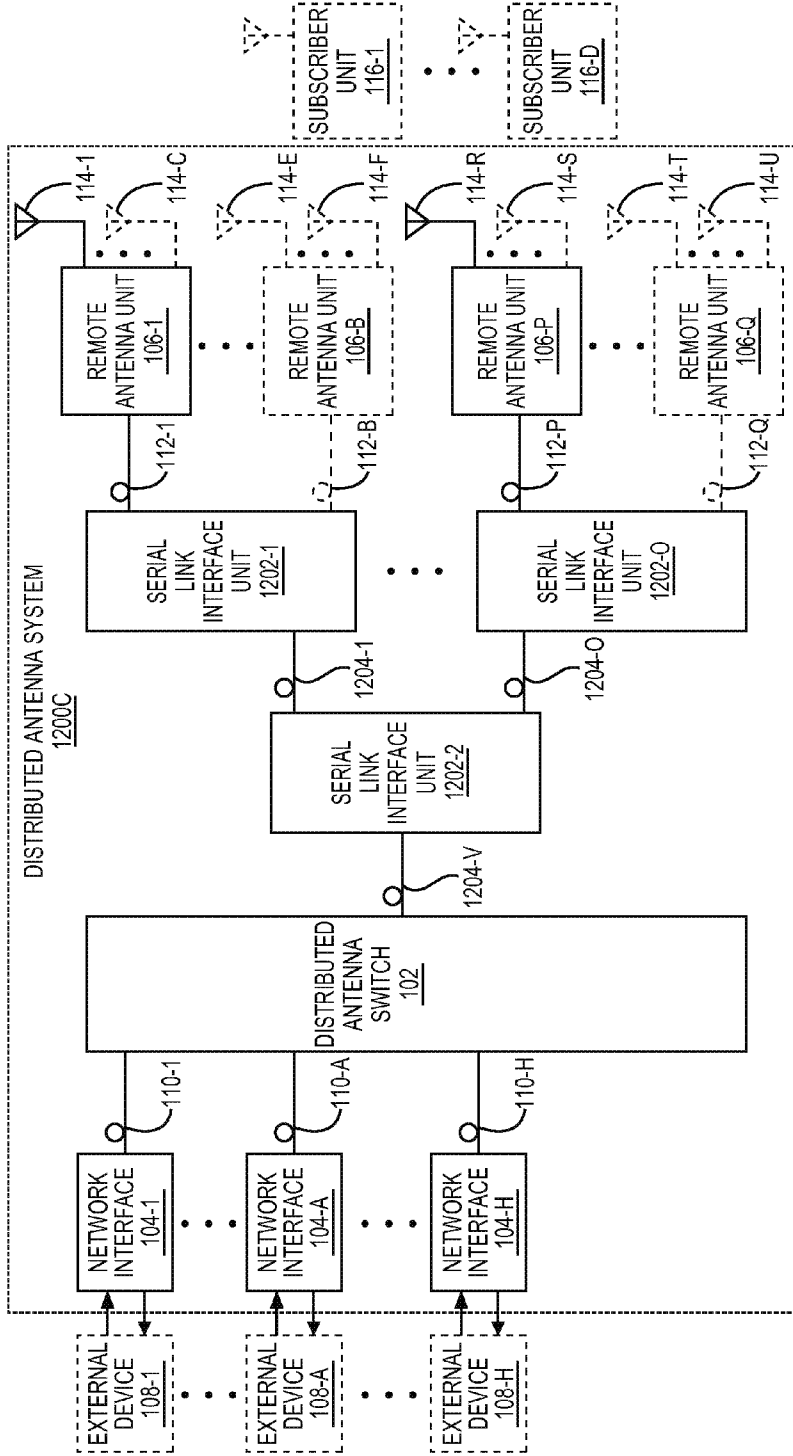

FIG. 12C

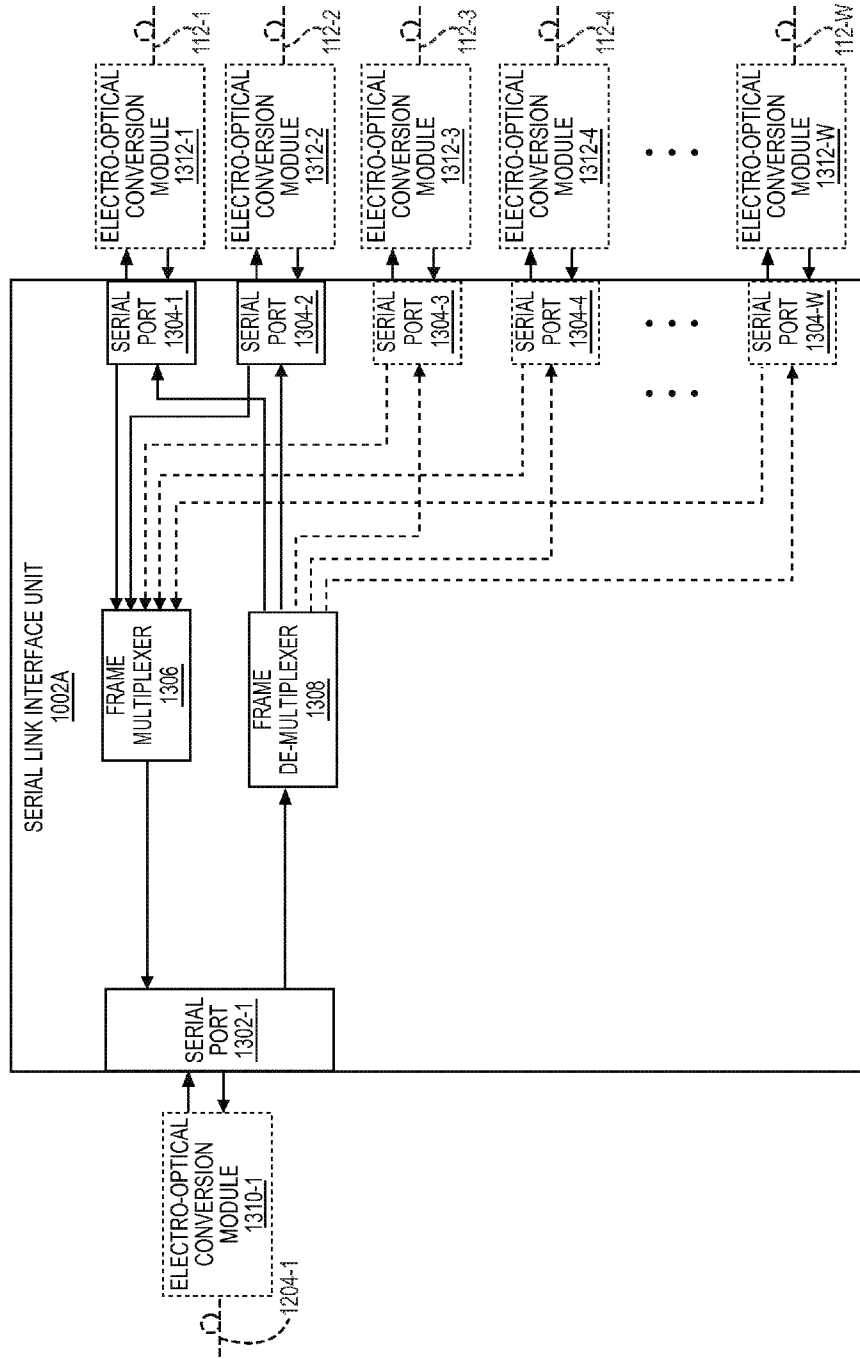

FIG. 13A

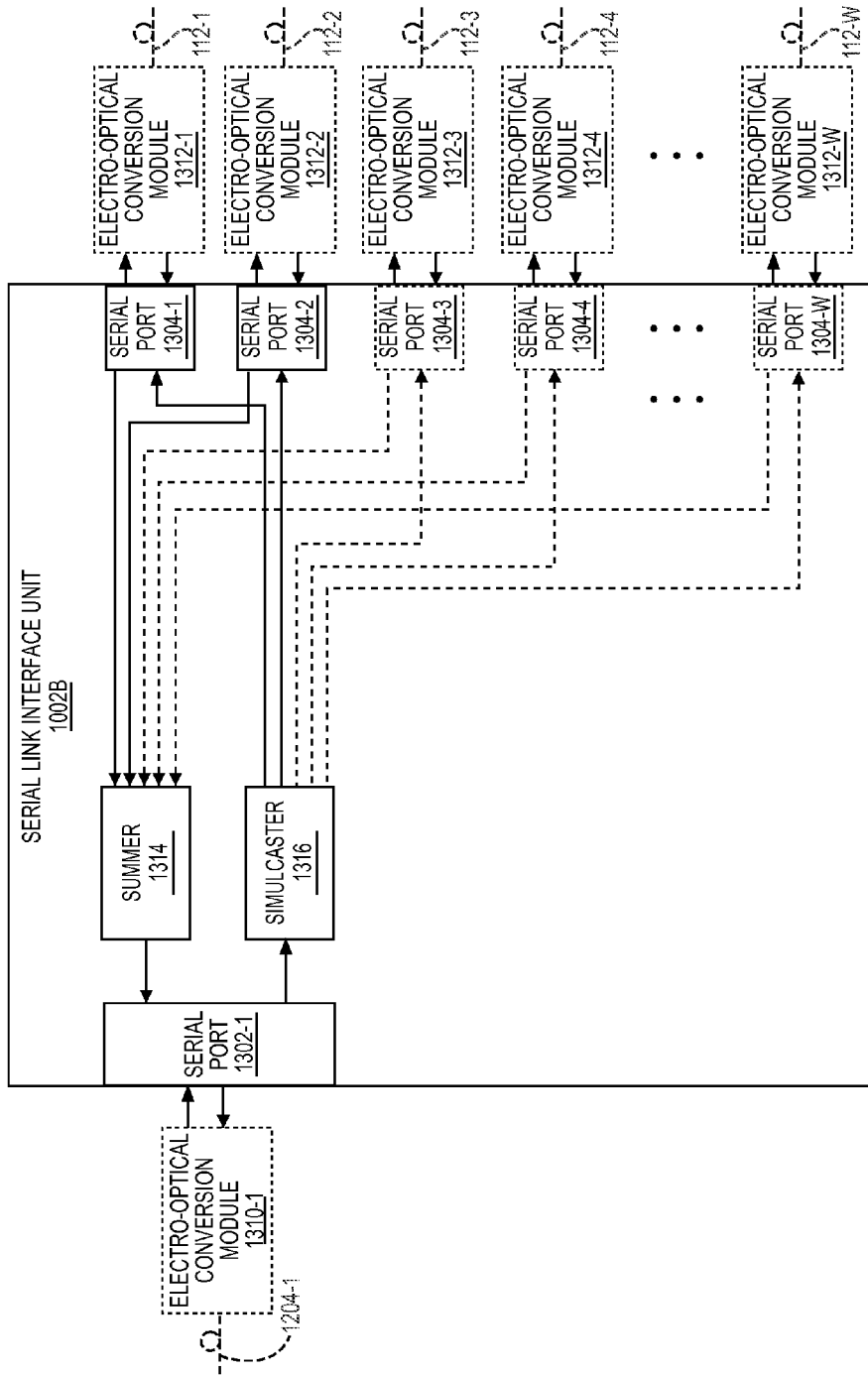

FIG. 13B

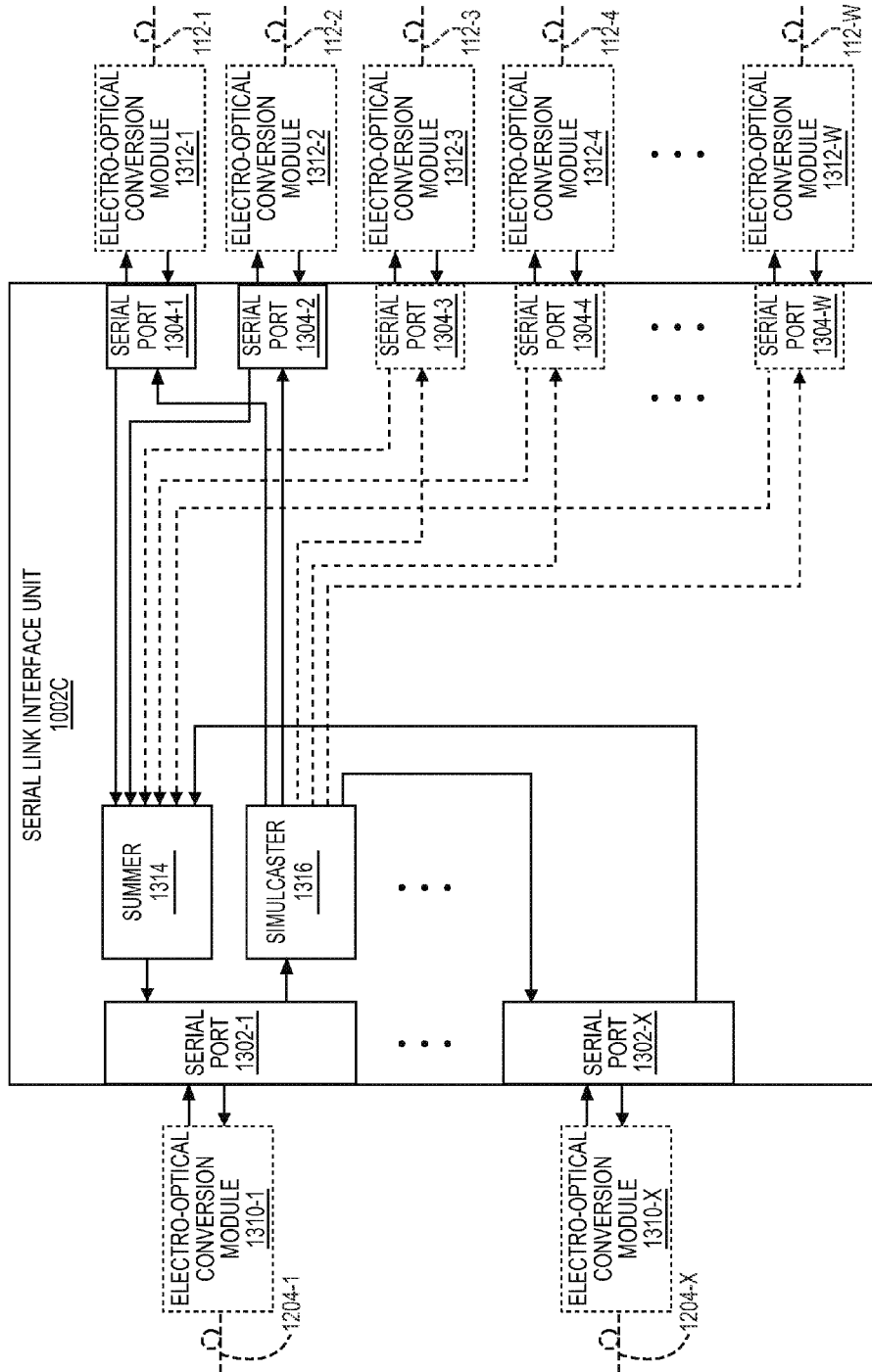

FIG. 13C

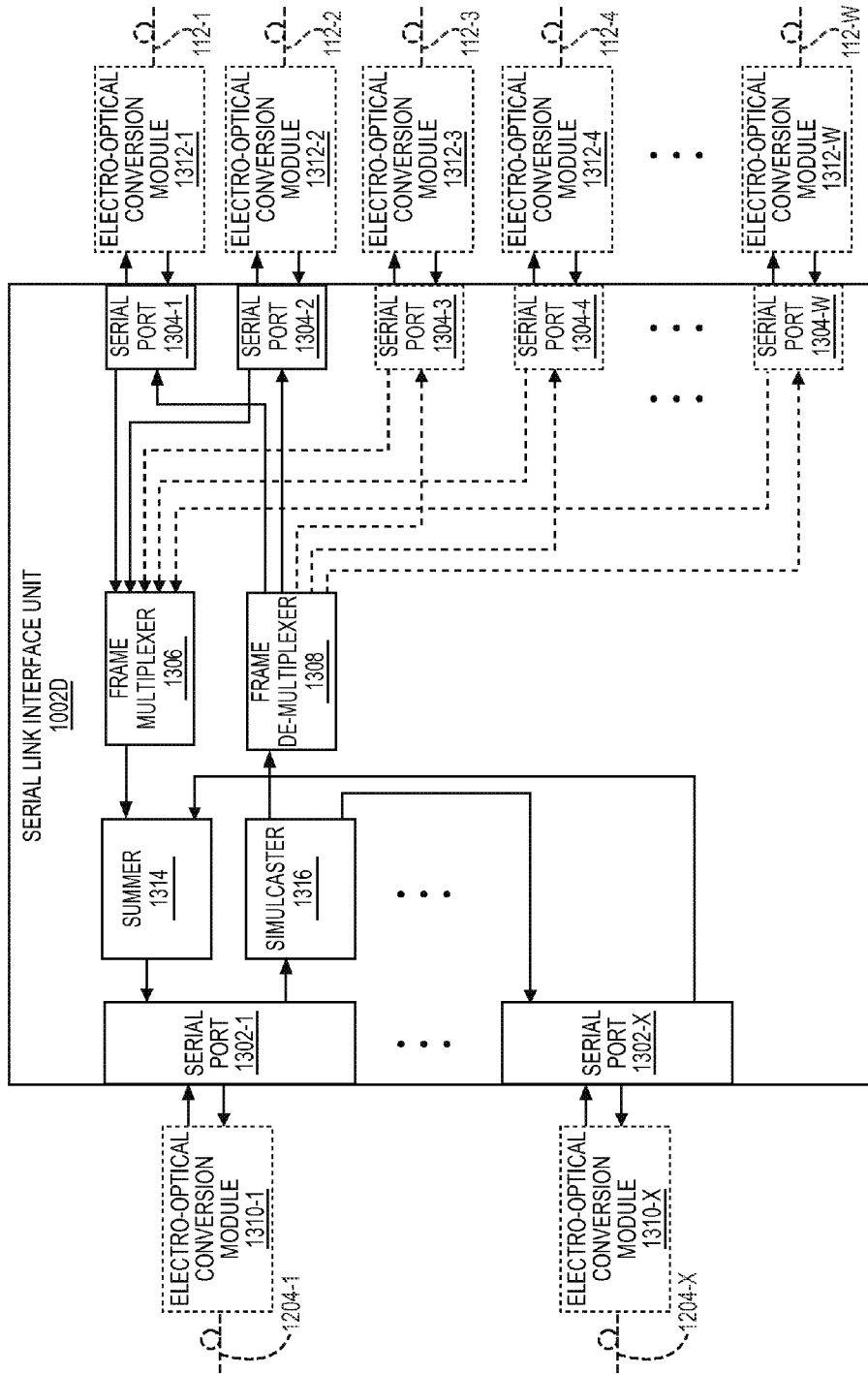

FIG. 13D

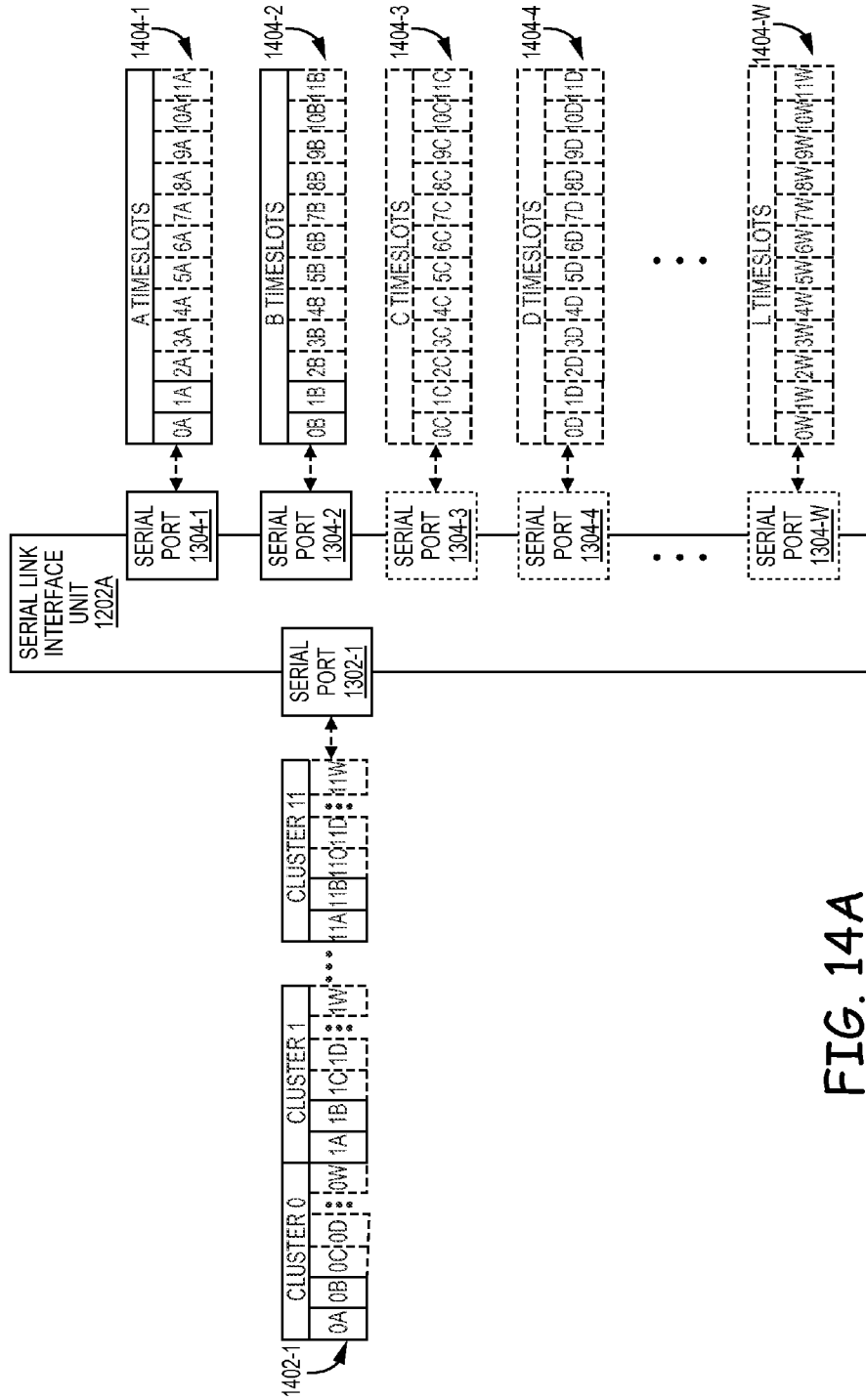

FIG. 14A

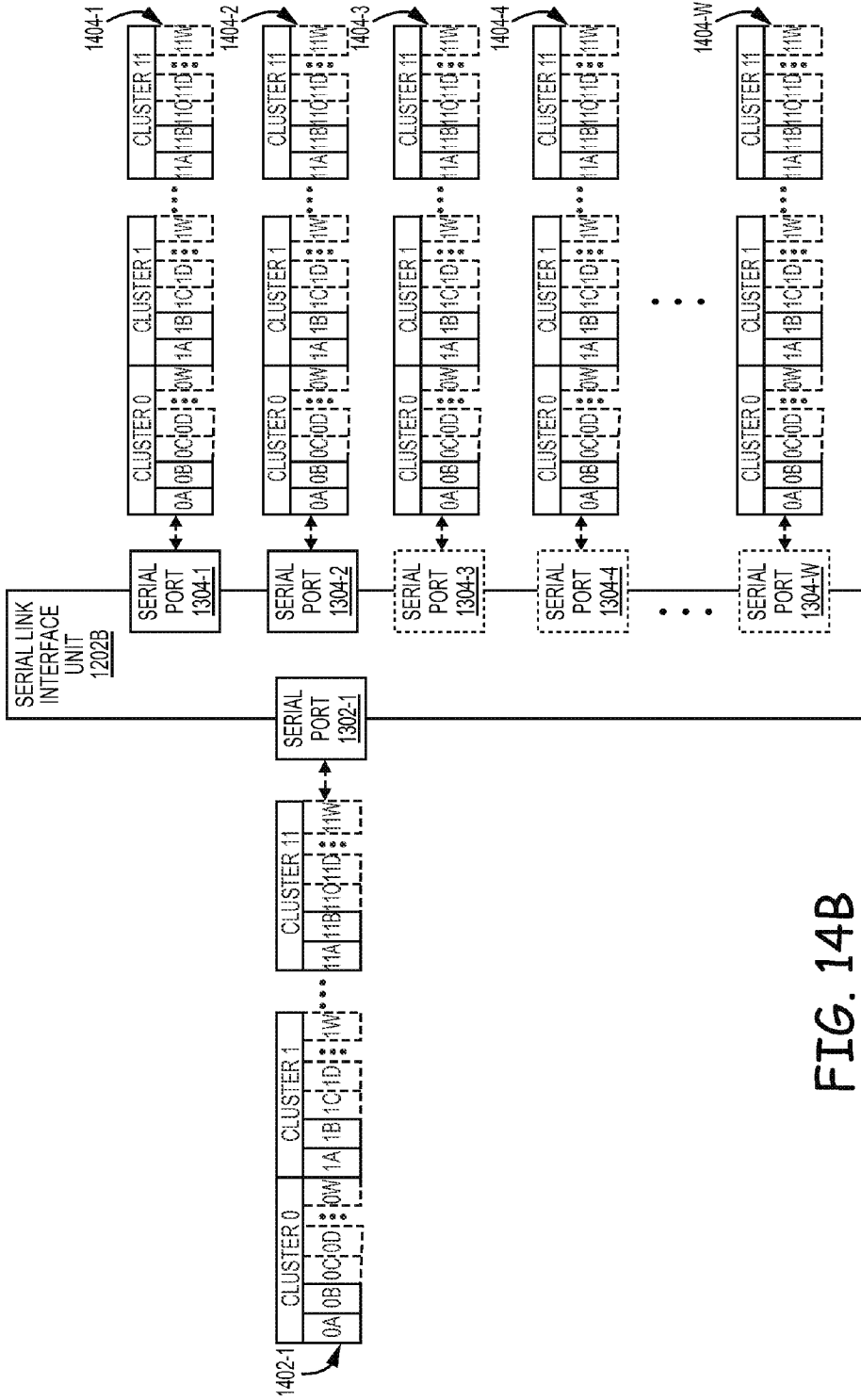

FIG. 14B

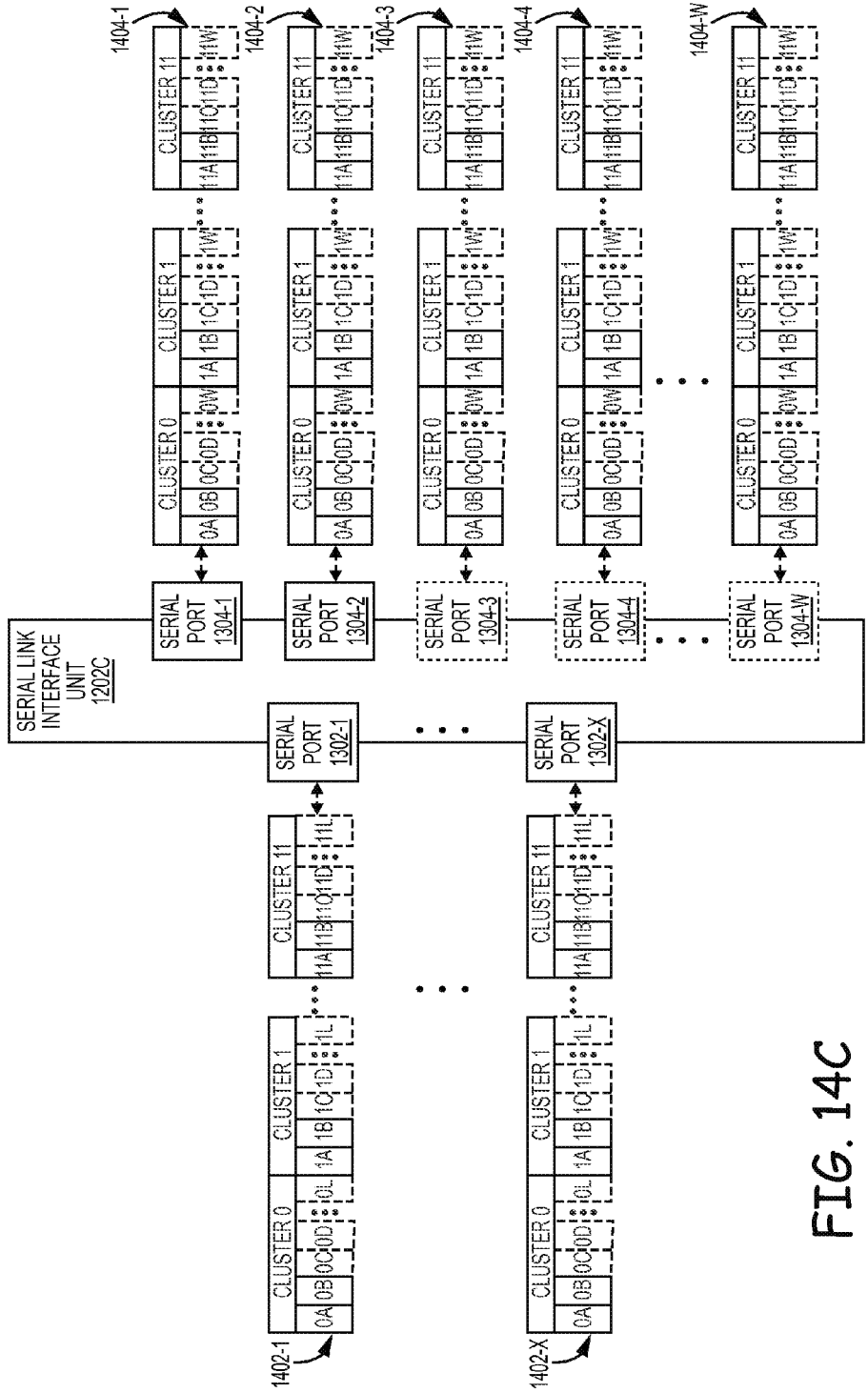

FIG. 14C



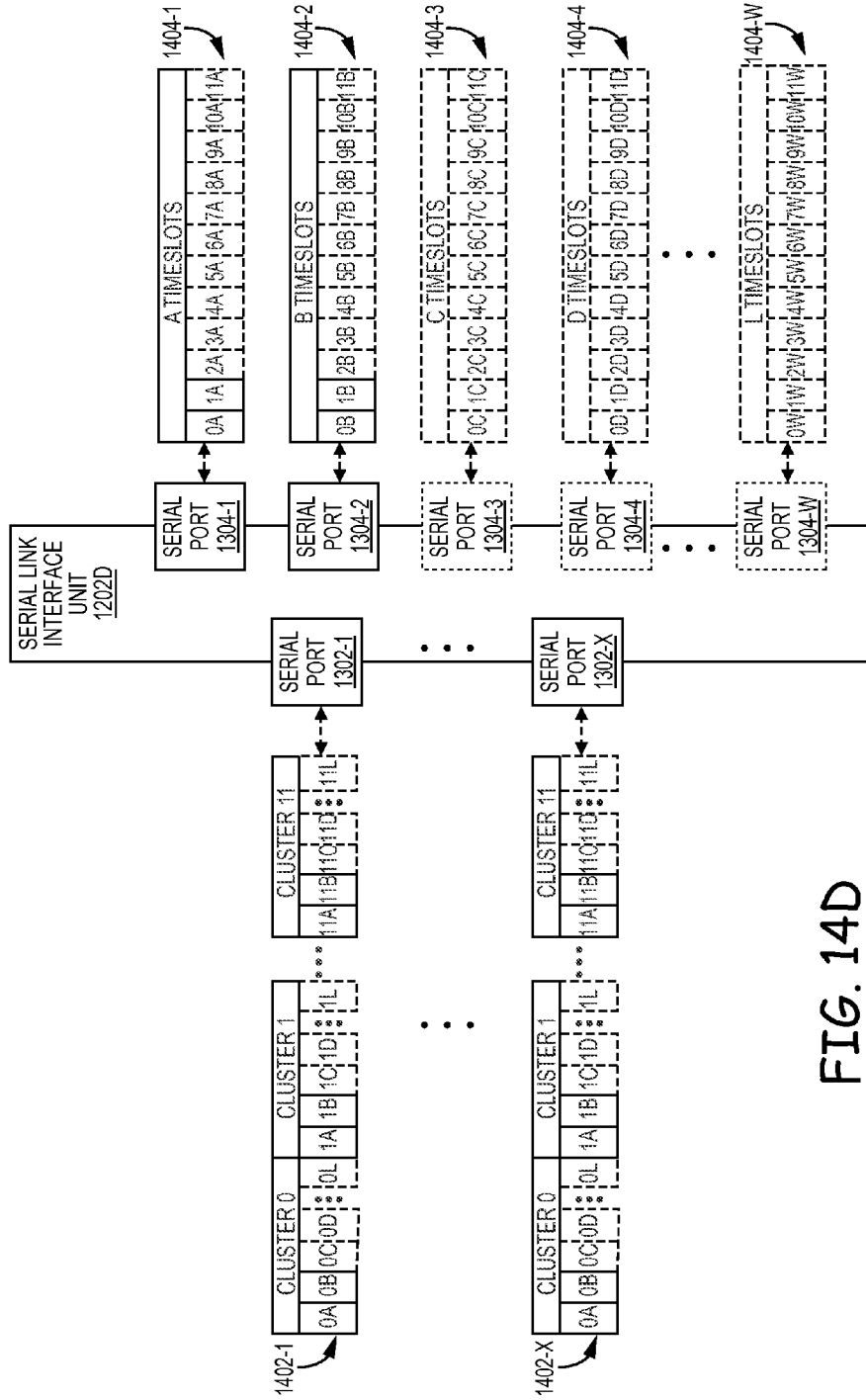

FIG. 14D

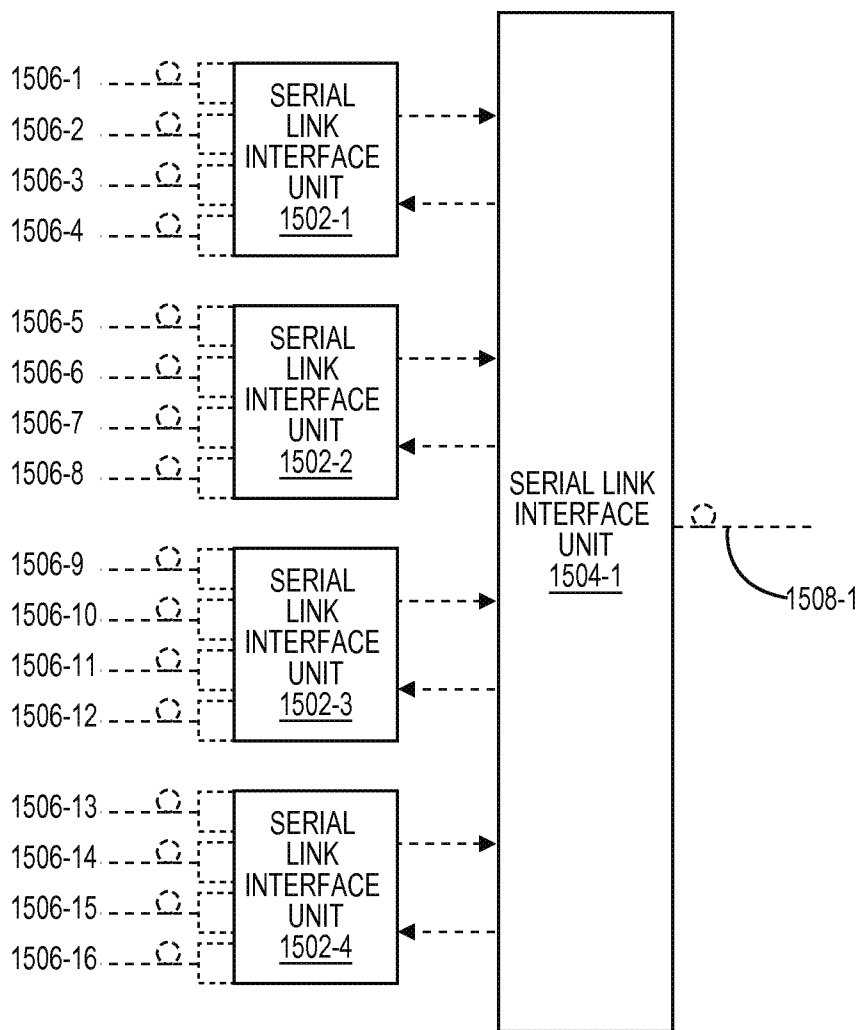

FIG. 15

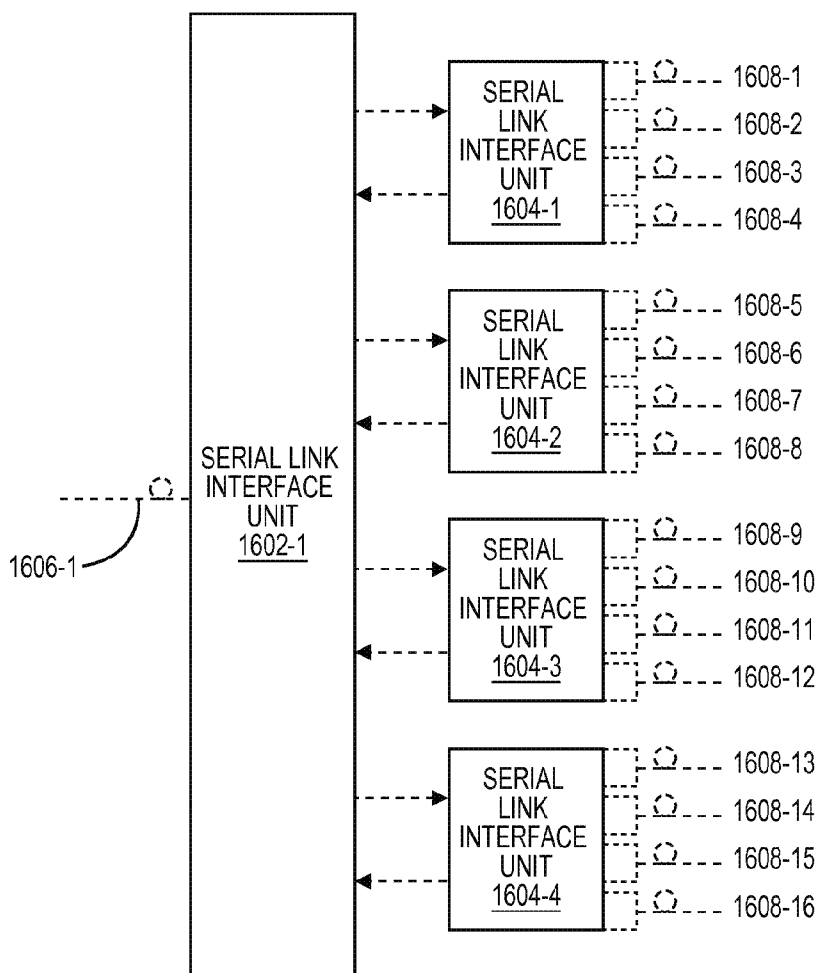

FIG. 16

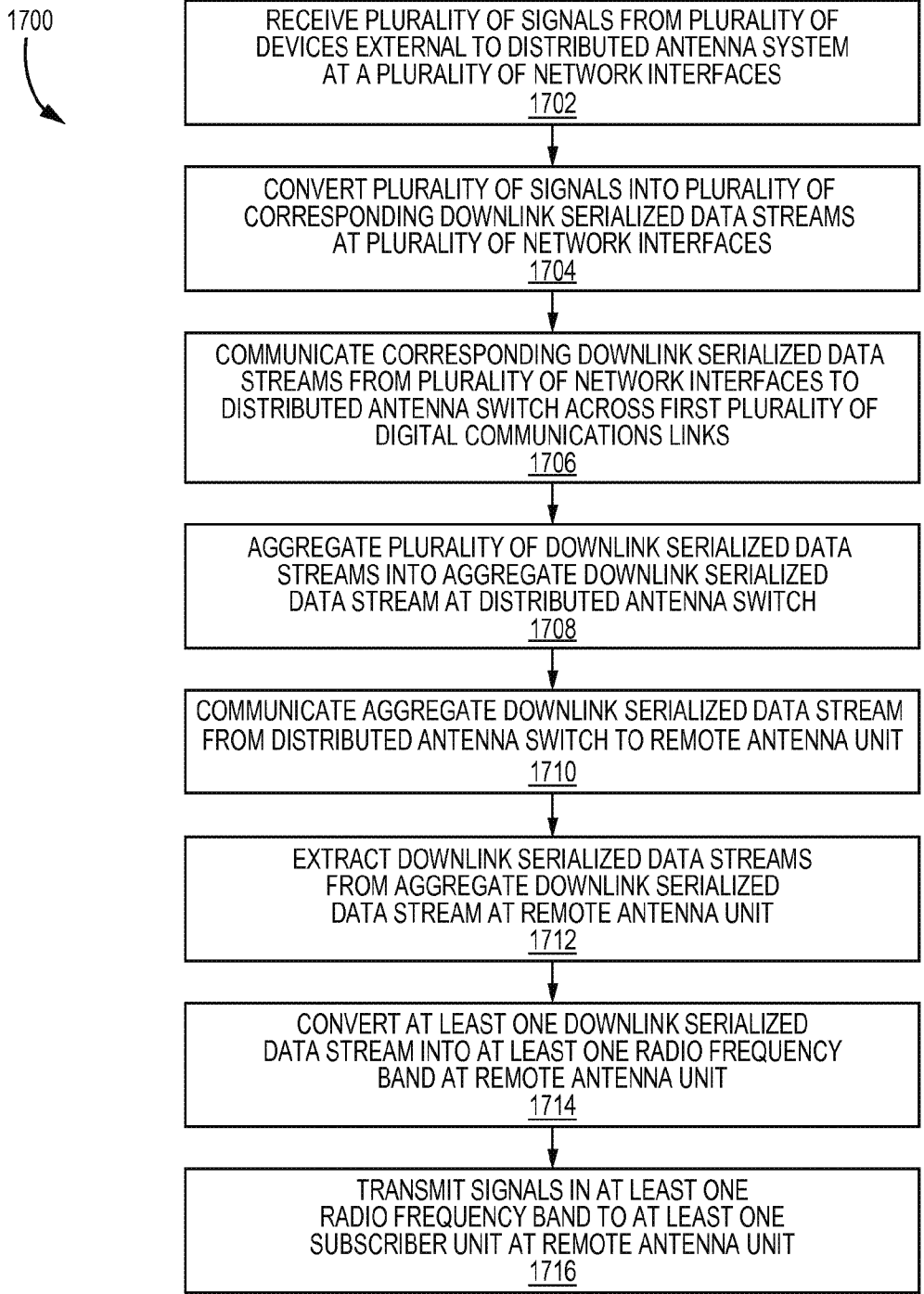

FIG. 17

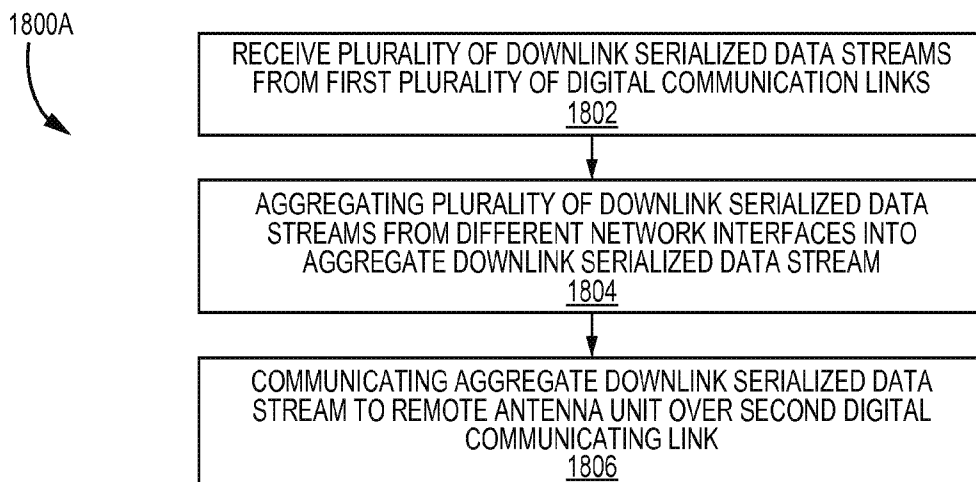

FIG. 18A

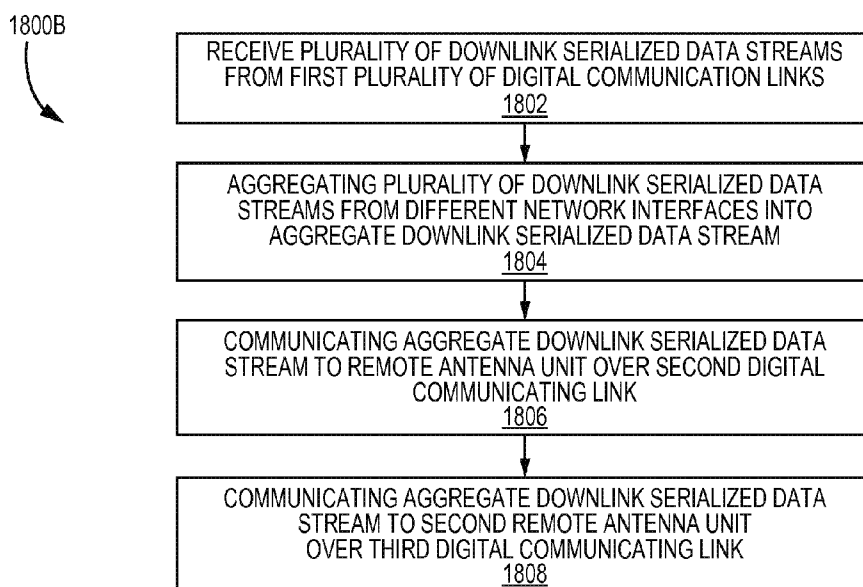

FIG. 18B

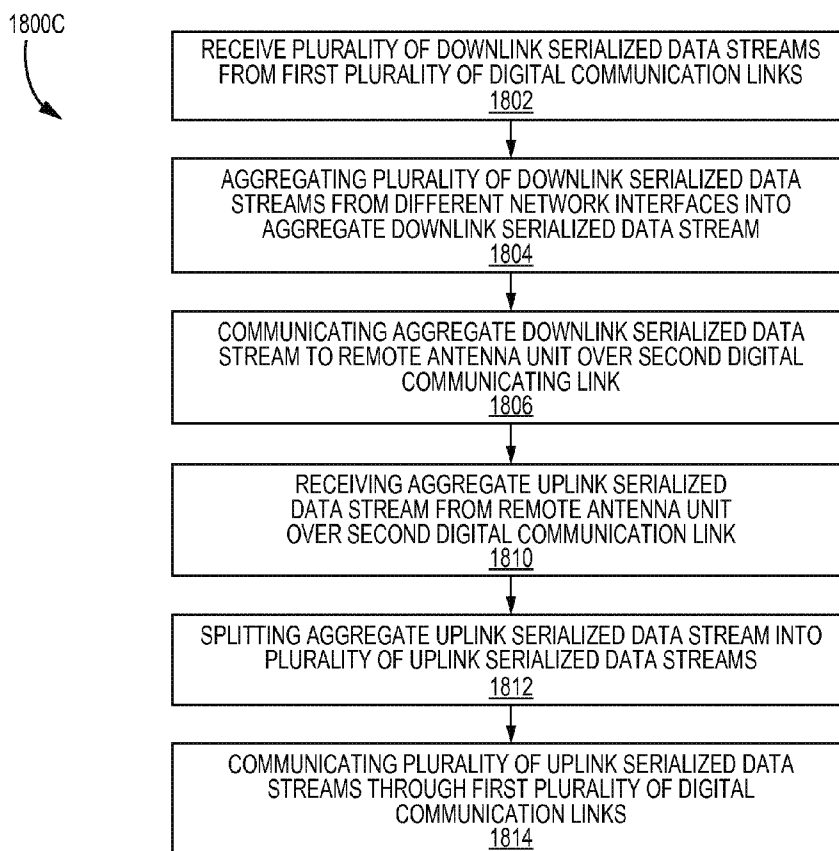

FIG. 18C

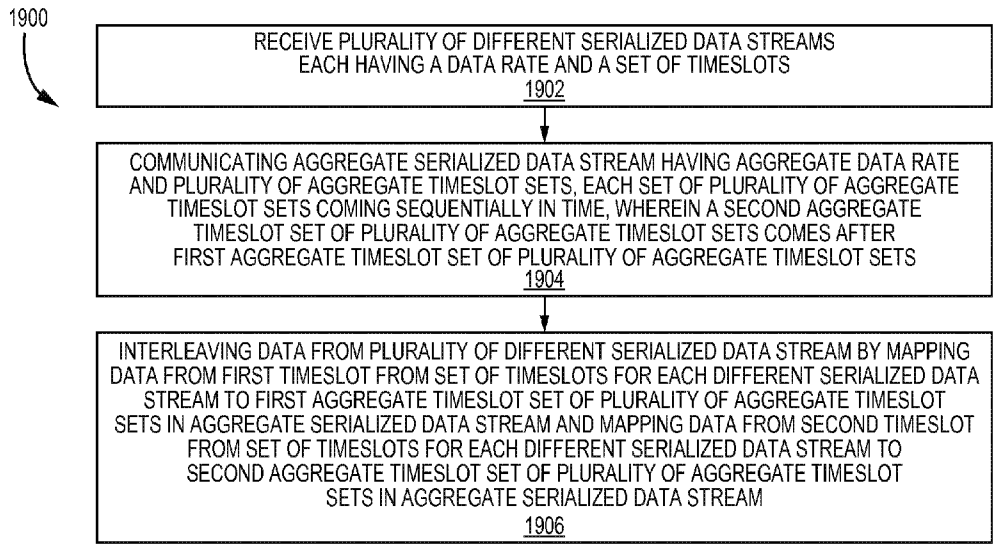

FIG. 19



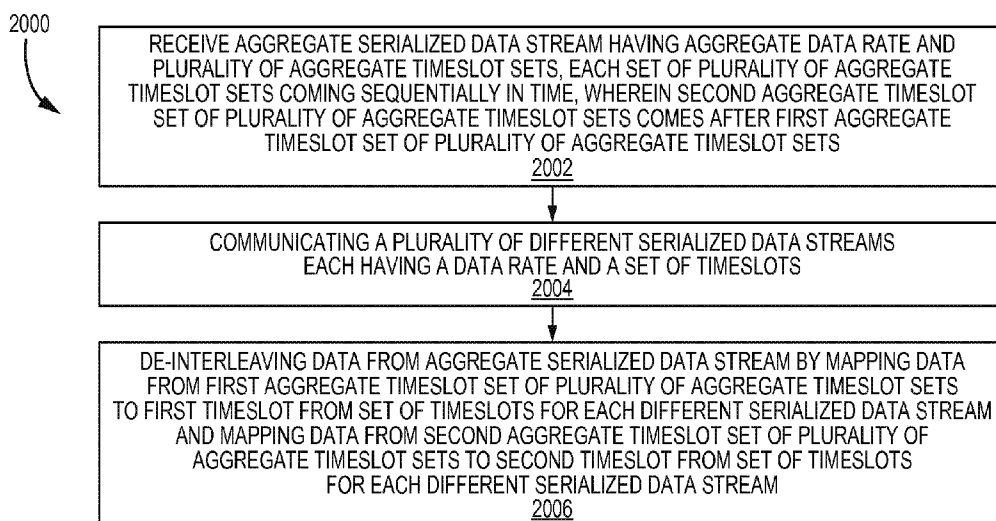

FIG. 20

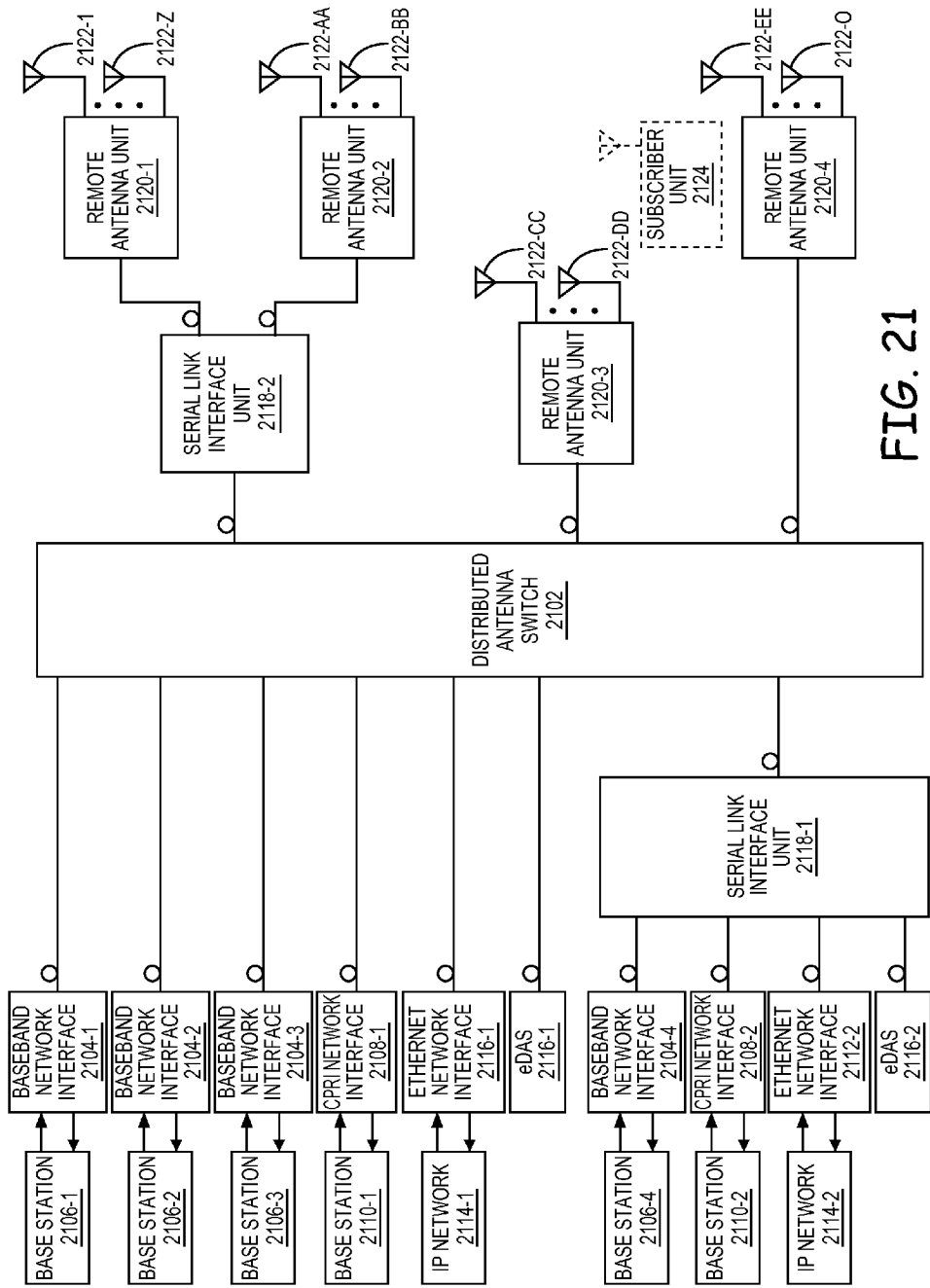

FIG. 21

**TIMESLOT MAPPING AND/OR  
AGGREGATION ELEMENT FOR DIGITAL  
RADIO FREQUENCY TRANSPORT  
ARCHITECTURE**

**CROSS-REFERENCE TO RELATED  
APPLICATIONS**

[0001] This application claims the benefit of U.S. Provisional Patent Application Ser. No. 61/729,789 filed on Nov. 26, 2012, which is hereby incorporated herein by reference.

[0002] This application is related to the following co-pending United States patent applications, all of which are hereby incorporated herein by reference:

[0003] U.S. Provisional Patent Application Ser. No. 61/729,786 filed on Nov. 26, 2012 (attorney docket number 100.1249USPR) entitled "FLEXIBLE, RECONFIGURABLE MULTIPOINT-TO-MULTIPOINT DIGITAL RADIO FREQUENCY TRANSPORT ARCHITECTURE", which is hereby incorporated herein by reference; and

[0004] U.S. Provisional Patent Application Ser. No. 61/729,792 filed on Nov. 26, 2012 (attorney docket number 100.1251USPR) entitled "FORWARD-PATH DIGITAL SUMMATION IN DIGITAL RADIO FREQUENCY TRANSPORT", which is hereby incorporated herein by reference.

**BACKGROUND**

[0005] Distributed Antenna Systems (DAS) are used to distribute wireless signal coverage into building or other substantially closed environments. For example, a DAS may distribute antennas within a building. The antennas are typically connected to a radio frequency (RF) signal source, such as a service provider. Various methods of transporting the RF signal from the RF signal source to the antenna have been implemented in the art.

**SUMMARY**

[0006] A serial link interface unit includes a plurality of serialized data stream interfaces, each of the plurality of serialized data stream interfaces configured to receive a different serialized data stream having a data rate and a set of timeslots; an aggregate serialized data stream interface configured to communicate an aggregate serialized data stream having an aggregate data rate and a plurality of aggregate timeslot sets, each set of the plurality of aggregate timeslot sets coming sequentially in time, wherein a second aggregate timeslot set of the plurality of aggregate timeslot sets comes after a first aggregate timeslot set of the plurality of aggregate timeslot sets; and wherein the serial link interface unit is configured to interleave data from the different serialized data streams received at the plurality of first interfaces by being configured to map data from a first timeslot from the set of timeslots for each different serialized data stream to the first aggregate timeslot set of the plurality of aggregate timeslot sets in the aggregate serialized data stream and being configured to map data from a second timeslot from the set of timeslots for each different serialized data stream to the second aggregate timeslot set of the plurality of aggregate timeslot sets in the aggregate serialized data stream.

**DRAWINGS**

[0007] Understanding that the drawings depict only exemplary embodiments and are not therefore to be considered

limiting in scope, the exemplary embodiments will be described with additional specificity and detail through the use of the accompanying drawings, in which:

[0008] FIG. 1 is a block diagram of one embodiment of an exemplary distributed antenna system.

[0009] FIGS. 2A-2D are block diagrams of exemplary embodiments of base station network interfaces used in distributed antenna systems, such as the exemplary distributed antenna system of FIG. 1.

[0010] FIGS. 3A-3B are block diagrams of exemplary embodiments of distributed antenna switches used in distributed antenna systems, such as the exemplary distributed antenna system of FIG. 1.

[0011] FIGS. 4A-4B are block diagrams of exemplary embodiments of serialized data stream routing units used in distributed antenna switches of distributed antenna systems, such as the exemplary distributed antenna system of FIG. 1.

[0012] FIGS. 5A-5B are block diagrams of exemplary embodiments of remote antenna units used in distributed antenna systems, such as the exemplary distributed antenna system of FIG. 1.

[0013] FIGS. 6A-6B are block diagrams of exemplary embodiments of a serialized data stream multiplexing unit used in remote antenna units of distributed antenna systems, such as the exemplary distributed antenna system of FIG. 1.

[0014] FIGS. 7A-7C are block diagrams of exemplary embodiments of radio frequency conversion modules used in remote antenna units of distributed antenna systems, such as the exemplary distributed antenna system of FIG. 1.

[0015] FIGS. 8A-8B are block diagrams of exemplary embodiments of Ethernet interfaces used in remote antenna units of distributed antenna systems, such as the exemplary distributed antenna system of FIG. 1.

[0016] FIGS. 9A-9C are block diagrams of embodiments of additional exemplary distributed antenna systems using serial link interface units positioned between network interfaces and a distributed antenna switch.

[0017] FIGS. 10A-10D are block diagrams of serial link interface units used in distributed antenna systems, such as the exemplary distributed antenna systems of FIGS. 9A-9C.

[0018] FIGS. 11A-11D are block diagrams showing timeslot mapping in the serial link interfaces of FIGS. 10A-10D.

[0019] FIGS. 12A-12C are block diagrams of embodiments of additional exemplary distributed antenna systems using serial link interface units positioned between a distributed antenna switch and remote units.

[0020] FIGS. 13A-13D are block diagrams of serial link interface units used in distributed antenna systems, such as the exemplary distributed antenna systems of FIGS. 12A-12C.

[0021] FIGS. 14A-14D are block diagrams showing timeslot mapping in the serial link interfaces of FIGS. 13A-13D.

[0022] FIG. 15 is a block diagram showing a number of serial link interface units operating together to aggregate a plurality of serialized data streams into a single aggregate serialized data stream.

[0023] FIG. 16 is a block diagram showing a number of serial link interface units operating together to split apart a single aggregate serialized data stream into a plurality of serialized data streams.

[0024] FIG. 17 is a flow diagram illustrating one exemplary embodiment of a method of aggregating and distributing serialized data streams in a distributed antenna system.

[0025] FIGS. 18A-18C are flow diagrams illustrating exemplary embodiments of methods of aggregating serialized data streams in a distributed antenna switch.

[0026] FIG. 19 is a flow diagram illustrating one exemplary embodiment of a method of aggregating a plurality of serialized data streams into an aggregate serialized data stream.

[0027] FIG. 20 is a flow diagram illustrating one exemplary embodiment of a method of splitting apart an aggregate serialized data stream into a plurality of serialized data stream.

[0028] FIG. 21 is a block diagram of an embodiment of an additional exemplary distributed antenna system having a distributed antenna switch and a variety of different network interfaces, serial link interface units, and remote antenna units.

[0029] In accordance with common practice, the various described features are not drawn to scale but are drawn to emphasize specific features relevant to the exemplary embodiments. Like reference numbers and designations in the various drawings indicate like elements.

#### DETAILED DESCRIPTION

[0030] In the following detailed description, reference is made to the accompanying drawings that form a part hereof, and in which is shown by way of illustration specific illustrative embodiments. However, it is to be understood that other embodiments may be utilized and that logical, mechanical, and electrical changes may be made. Furthermore, the method presented in the drawing figures and the specification is not to be construed as limiting the order in which the individual steps may be performed. The following detailed description is, therefore, not to be taken in a limiting sense.

[0031] The embodiments described below describe a distributed antenna system and components within the distributed antenna system. The various components of the distributed antenna system communicate using serialized data streams. In exemplary embodiments, the serialized data stream use different communication rates in different portions of the distributed antenna system. Generally in the forward path, the distributed antenna system includes a single distributed antenna switch that receives a plurality of serialized data streams from a plurality of network interfaces and then routes data from various timeslots of the plurality of serialized data streams to various remote antenna units. Likewise in the reverse path, the single distributed antenna switch of the distributed antenna system receives serialized data streams from various remote antenna units and routes data from various timeslots of the serialized data streams to the plurality of network interfaces.

[0032] FIG. 1 is a block diagram of one exemplary embodiment of a digital distributed antenna system (DAS) 100 that includes a distributed antenna switch 102 communicatively coupled to a plurality of network interfaces 104 (including network interface 104-1, network interface 104-2, and any amount of optional network interfaces 104 through optional network interface 104-A) and at least one remote antenna unit 106 (including remote antenna unit 106-1 and any amount of optional remote antenna units 106 through optional remote antenna unit 106-B).

[0033] Each network interface 104 is communicatively coupled to an external device 108 that is configured to provide signals to be transported through the distributed antenna sys-

tem 100 to the network interface 104. In the forward path, each network interface 104 is configured to receive signals from at least one external device 108. Specifically, network interface 104-1 is communicatively coupled to external device 108-1, network interface 104-2 is communicatively coupled to external device 108-2, and optional network interface 104-A is communicatively coupled to optional external device 108-A. Each network interface 104 is also communicatively coupled to the distributed antenna switch 102 across a digital communication link 110. Specifically, network interface 104-1 is communicatively coupled to a port of distributed antenna switch 102 across digital communication link 110-1, network interface 104-2 is communicatively coupled to a port of distributed antenna switch 102 across digital communication link 110-2, and optional network interface 104-A is communicatively coupled to a port of distributed antenna switch 102 across digital communication link 110-A. As described in more detail below, each network interface 104 is configured to convert signals from the external device 108 to which it is communicatively coupled into a downlink serialized data stream and further configured to communicate the downlink serialized data stream to the distributed antenna switch 102 (either directly or through other components of the distributed antenna system 100 (such as serial link interface units) described in detail below) across a respective digital communication link 110.

[0034] Similarly in the reverse path, in exemplary embodiments each network interface 104 is configured to receive uplink serialized data streams across a respective digital communication link 110. Each network interface 104 is further configured to convert the received uplink serialized data stream to signals formatted for the associated external device 108 and further configured to communicate the signals formatted for the associated external device 108 to the associated external device 108.

[0035] Distributed antenna switch 102 is configured to receive signals from the plurality of network interfaces 104 (including network interface 104-1 and network interface 104-2 and any amount of optional network interfaces 104 through optional network interface 104-A) across the plurality of digital communication links 110 (including digital communication link 110-1 and digital communication link 110-2 and any amount of optional digital communication link 110-1 through optional digital communication link 110-A). In the forward path, an exemplary embodiment of distributed antenna switch 102 is configured to aggregate the plurality of downlink serialized data streams received from the first plurality of digital communication links 110 into an aggregate downlink serialized data stream. In exemplary embodiments, distributed antenna switch 102 is configured to selectively aggregate some of the plurality of downlink serialized data streams into one or more aggregate downlink serialized data stream. For example, one aggregate data stream may include timeslots received from both network interface 104-1 and network interface 104-2, while another aggregate data stream may include timeslots received from optional network interface 104-3 (not shown) and optional network interface 104-A. Alternatively, one aggregate data stream may include timeslots received from both network interface 104-2, optional network interface 104-4, and optional network interface 104-A, while another aggregate data stream may include timeslots received from network interface 104-1, optional network interface 104-3, and optional network interface 104-5. In other embodiments, other combinations of data from

serialized data streams are aggregated in different ways and other quantities of aggregate data streams are included. Distributed antenna switch **102** is further configured to communicate the one or more aggregate serialized data streams to one or more remote antenna units **106** across one or more digital communication link **112**. In exemplary embodiments where data streams are selectively aggregated at the distributed antenna switch **102**, the aggregate data streams can then be selectively communicated to various remote antenna units **106**, thereby enabling the distributed antenna system **100** to selectively route traffic between network interfaces and remote antenna units in a number of different ways.

**[0036]** Similarly in the reverse path, in exemplary embodiments the distributed antenna switch **102** is configured to receive one or more uplink aggregate serial data stream across one or more digital communication link **112**. The distributed antenna switch **102** is further configured to extract at least one uplink serialized data stream from the one or more uplink aggregate serial data stream. The distributed antenna switch is further configured to communicate the at least one uplink serialized data stream across at least one digital communication link **110** to at least one network interface **104**.

**[0037]** Each remote antenna unit **106** is communicatively coupled to the distributed antenna switch **102** across a digital communication link **112**. Specifically, remote antenna unit **106-1** is communicatively coupled to a port of the distributed antenna switch **102** across digital communication link **112-1** and optional remote antenna unit **106-B** is communicatively coupled to a port of the distributed antenna switch **102** across digital communication link **112-B**. Each remote antenna unit includes components configured for extracting at least one downlink serialized data stream from an aggregate downlink serialized data stream and components configured for aggregating at least one uplink serialized data stream into an aggregate uplink serialized data stream as well as at least one radio frequency converter configured to convert between at least one serialized data streams and at least one radio frequency band and at least one radio frequency transceiver and antenna **114** pair configured to transmit and receive signals in the at least one radio frequency band to at least one subscriber unit **116**.

**[0038]** In the downstream, each remote antenna unit **106** is configured to extract at least one downlink serialized data stream from the downlink aggregate serialized data stream. Each remote antenna unit **106** is further configured to convert the at least one downlink serialized data stream into a downlink radio frequency (RF) signal in a radio frequency band. In exemplary embodiments, this may include digital to analog converters and oscillators. Each remote antenna unit **106** is further configured to transmit the downlink radio frequency signal in the radio frequency band to at least one subscriber unit using at least one radio frequency transceiver and antenna **114** pair. In a specific exemplary embodiment, remote antenna unit **106-1** is configured to extract at least one downlink serialized data stream from the downlink aggregate serialized data stream received from the distributed antenna switch **102** and further configured to convert the at least one downlink serialized data stream into a downlink radio frequency signal in a radio frequency band. Remote antenna unit **106-1** is further configured to transmit the downlink radio frequency signal in a radio frequency band using a radio frequency and antenna **114-1** pair to at least one subscriber unit **116-1**. In exemplary embodiments, remote antenna unit **106-1** is configured to extract a plurality of downlink serial-

ized data streams from the downlink aggregate serialized data stream received from the distributed antenna switch **102** and configured to convert the plurality of downlink serialized data streams to a plurality of downlink radio frequency signals. In exemplary embodiments with a plurality of radio frequency signals, the remote antenna unit **106-1** is further configured to transmit the downlink radio frequency signal in at least one radio frequency band to at least subscriber unit **116-1** using at least radio frequency transceiver and antenna **114-1** pair. In exemplary embodiments, the remote antenna unit **106-1** is configured to transmit one downlink radio frequency signal to one subscriber unit **116-1** using one antenna **114-1** and another radio frequency signal to another subscriber unit **116-D** using another antenna **114-C**. Other combinations of radio frequency transceiver and antenna **114** pairs are used to communicate other combinations of radio frequency signals in other various radio frequency bands to various subscriber units **116**.

**[0039]** Similarly in the reverse path, in exemplary embodiments each remote antenna unit **106** is configured to receive uplink radio frequency signals from at least one subscriber unit **116** using at least one radio frequency transceiver and antenna **114** pair. Each remote antenna unit **106** is further configured to convert the radio frequency signals to at least one uplink serialized data stream. Each remote antenna unit **106** is further configured to aggregate the at least one uplink serialized data stream into an aggregate uplink serialized data stream and further configured to communicate the aggregate uplink serialized data stream across at least one digital communication link **112** to the distributed antenna switch **102**.

**[0040]** FIG. 2A-2D are block diagrams depicting exemplary embodiments of base station network interfaces **104** used in distributed antenna systems, such as exemplary distributed antenna system **100** described above. Each of FIGS. 2A-2D illustrates a different embodiment of a type of base station network interface **104**, labeled **104A-104D** respectively.

**[0041]** FIG. 2A is a block diagram of an exemplary embodiment of a type base station network interface **104**, radio frequency (RF) network interface **104A**. Radio frequency network interface **104A** includes a radio frequency (RF) to optical serialized data stream conversion module **202A** communicatively coupled to a radio frequency (RF) base station output **204A** of an external device **108** that is a radio frequency access base station. Radio frequency to optical serialized data stream conversion module **202A** is also communicatively coupled to at least one digital communication link **110**. In exemplary embodiments, the radio frequency to optical serialized data stream conversion module **202A** is implemented using optional processor **206** and memory **208**. In exemplary embodiments, the radio frequency network interface **104A** includes optional power supply **210** to power the radio frequency to optical serialized data stream conversion module **202A** and/or optional processor **206** and memory **208**.

**[0042]** In the downlink, radio frequency to serialized data stream conversion module **202A** is configured to receive radio frequency signals from the radio frequency base station output **204A**. The radio frequency to optical serialized data stream conversion module **202A** is further configured to convert the received radio frequency signals to a downlink serialized data stream. In exemplary embodiments, this is done using oscillators and mixers. In exemplary embodiments, the radio frequency to optical serialized data stream conversion

module 202A further converts the serialized data stream from electrical signals to optical signals for output on digital communication link 110. In other embodiments, the serialized data stream is transported using a conductive communication medium, such as coaxial cable or twisted pair, and the optical conversion is not necessary.

[0043] In the uplink, radio frequency to serialized data stream conversion module 202A is configured to receive a serialized data stream across digital communication link 110. In exemplary embodiments where digital communication link 110 is an optical medium, the radio frequency to optical serialized data stream conversion module 202A is configured to convert the uplink serialized data stream between received optical signals and electrical signal. In other embodiments, the serialized data stream is transported using a conductive communication medium, such as coaxial cable or twisted pair, and the optical conversion is not necessary. The radio frequency to optical serialized data stream conversion module is further configured to convert the uplink serialized data stream to radio frequency signals. In exemplary embodiments, this is done using oscillators and mixer. Radio frequency to optical serialized data stream conversion module 202A is further configured to communicate the uplink radio frequency signal to the radio frequency base station output 204A.

[0044] FIG. 2B is a block diagram of an exemplary embodiment of a type of base station network interface 104, baseband network interface 104B. Baseband network interface 104B includes a baseband to optical serialized data stream conversion module 202B communicatively coupled to a baseband base station output 204B of an external device 108 that is a radio frequency access base station. Baseband to optical serialized data stream conversion module 202B is also communicatively coupled to at least one digital communication link 110. In exemplary embodiments, the baseband to optical serialized data stream conversion module 202B is implemented using optional processor 206 and memory 208. In exemplary embodiments, the baseband network interface 104B includes optional power supply 210 to power the baseband to optical serialized baseband conversion module 202B and/or optional processor 206 and memory 208.

[0045] In the downlink, baseband to optical serialized data stream conversion module 202B is configured to receive baseband mobile wireless access signals (such as I/Q data) from the baseband base station output 204B. The baseband to optical serialized conversion module 202B is further configured to convert the received baseband mobile wireless access signals to a downlink serialized data stream. In exemplary embodiments, the baseband to optical serialized data stream conversion module 202B further converts the serialized data stream from electrical signals to optical signals for output on the digital communication link 110. In other embodiments, the serialized data stream is transported using a conductive communication medium, such as coaxial cable or twisted pair, and the optical conversion is not necessary.

[0046] In the uplink, baseband to optical serialized data stream conversion module 202B is configured to receive a serialized data stream across digital communication link 110. In exemplary embodiments where digital communication link 110 is an optical medium, the baseband to optical serialized data stream conversion module 202B is configured to convert the uplink serialized data stream between received optical signals and electrical signal. In other embodiments, the serialized data stream is transported using a conductive

communication medium, such as coaxial cable or twisted pair, and the optical conversion is not necessary. The baseband to optical serialized data stream conversion module 202B is further configured to convert the uplink serialized data stream to uplink baseband wireless access signals. Baseband to optical serialized data stream conversion module 202B is further configured to communicate the uplink baseband wireless access signals to the baseband base station output 204B.

[0047] FIG. 2C is a block diagram of an exemplary embodiment of a type of base station network interface 104, Common Public Radio Interface (CPRI) network interface 104C. CPRI network interface 104C includes a CPRI to optical serialized data stream conversion module 202C communicatively coupled to a baseband base station output 204B of an external device 108 that is a radio frequency access base station. CPRI to optical serialized data stream conversion module 202C is also communicatively coupled to at least one digital communication link 110. In exemplary embodiments, the CPRI to optical serialized data stream conversion module 202C is implemented using optional processor 206 and memory 208. In exemplary embodiments, the CPRI network interface 104C includes optional power supply 210 to power the baseband to optical serialized baseband conversion module 202B and/or optional processor 206 and memory 208.

[0048] In the downlink, CPRI to optical serialized data stream conversion module 202C is configured to receive CPRI signals from the CPRI base station output 204C. The CPRI to optical serialized data stream conversion module 202C is further configured to convert the received CPRI signals to a downlink serialized data stream. In exemplary embodiments, the CPRI to optical serialized data stream conversion module 202C further converts the serialized data stream from electrical signals to optical signals for output on the digital communication link 110. In other embodiments, the serialized data stream is transported using a conductive communication medium, such as coaxial cable or twisted pair, and the optical conversion is not necessary.

[0049] In the uplink, CPRI to optical serialized data stream conversion module 202C is configured to receive a serialized data stream across digital communication link 110. In exemplary embodiments where digital communication link 110 is an optical medium, the CPRI to optical serialized data stream conversion module 202C is configured to convert the uplink serialized data stream between received optical signals and electrical signal. In other embodiments, the serialized data stream is transported using a conductive communication medium, such as coaxial cable or twisted pair, and the optical conversion is not necessary. The CPRI to optical serialized data stream conversion module 202C is further configured to convert the uplink serialized data stream to uplink CPRI signals. CPRI to optical serialized data stream conversion module 202C is further configured to communicate the uplink CPRI signal to the CPRI base station output 204C.

[0050] FIG. 2D is a block diagram of an exemplary embodiment of a type of base station network interface 104, Ethernet network interface 104D. Ethernet network interface 104D includes an Ethernet to optical serialized data stream conversion module 202D communicatively coupled to an Ethernet output 204D of an external device 108 that is an Ethernet adapter to a internet protocol (IP) based network. Ethernet to optical serialized data stream conversion module 202D is also communicatively coupled to at least one digital communication link 110. In exemplary embodiments, the

Ethernet to optical serialized data stream conversion module **202D** is implemented using optional processor **206** and memory **208**. In exemplary embodiments, the Ethernet network interface **104D** includes optional power supply **210** to power the baseband to optical serialized baseband conversion module **202B** and/or optional processor **206** and memory **208**.

[0051] In the downlink, Ethernet to optical serialized data stream conversion module **202D** is configured to receive internet protocol packets from the Ethernet output **204D**. The baseband to optical serialized conversion module **202B** is further configured to convert the internet protocol packets to a downlink serialized data stream. In exemplary embodiments, the Ethernet to optical serialized data stream conversion module **202D** further converts the serialized data stream from electrical signals to optical signals for output on the digital communication link **110**. In other embodiments, the serialized data stream is transported using a conductive communication medium, such as coaxial cable or twisted pair, and the optical conversion is not necessary.

[0052] In the uplink, Ethernet to optical serialized data stream conversion module **202D** is configured to receive a serialized data stream across digital communication link **110**. In exemplary embodiments where digital communication link **110** is an optical medium, the Ethernet to optical serialized data stream conversion module **202D** is configured to convert the uplink serialized data stream between received optical signals and electrical signal. In other embodiments, the serialized data stream is transported using a conductive communication medium, such as coaxial cable or twisted pair, and the optical conversion is not necessary. The Ethernet to optical serialized data stream conversion module **202D** is further configured to convert the uplink serialized data stream to uplink Ethernet frames. Ethernet to optical serialized data stream conversion module **202D** is further configured to communicate the uplink Ethernet frames to the Ethernet output **204D**.

[0053] FIGS. 3A-3B are block diagrams depicting exemplary embodiments of distributed antenna switches **102** used in distributed antenna systems, such as the exemplary distributed antenna system **100** described above. Each of FIGS. 3A-3B illustrates a different embodiment of distributed antenna switch **102**, labeled distributed antenna switch **102A-102B** respectively.

[0054] FIG. 3A is a block diagram of an exemplary distributed antenna switch **102A** including a serialized data stream routing unit **302A**, electro-optical conversion modules **304** (including electro-optical conversion module **304-1**, electro-optical conversion module **304-2**, and any amount of optional electro-optical conversion modules **304** through optional electro-optical conversion module **304-A**) and at least one electro-optical conversion module **306-1** (and any amount of optional electro-optical conversion modules **306** through optional electro-optical conversion modules **306-B**). In exemplary embodiments, the serialized data stream routing unit **302A** is implemented using optional processor **308** and memory **310**. In exemplary embodiments, the serialized data stream routing unit **302A** includes optional power supply **312** to power the serialized data stream routing unit **302A** and/or optional processor **308** and memory **310**.

[0055] Each electro-optical conversion module **304** is communicatively coupled to a network interface **104** across a digital communication link **110**. In the forward path, each electro-optical conversion module **304** is configured to

receive a downlink digitized data stream from at least one network interface **104** across a digital communication link **110**. Specifically, electro-optical conversion module **304-1** is configured to receive a downlink digitized data stream from network interface **104-1** across digital communication link **110-1**, electro-optical conversion module **304-2** is configured to receive a downlink digitized data stream from network interface **104-2** across digital communication link **110-2**, and optional electro-optical conversion module **304-A** is configured to receive a downlink digitized data stream from optional network interface **104-A** across optional digital communication link **110-A**. Each electro-optical conversion module **304** is configured to convert the downlink digitized data streams from optical to electrical signals, which are then passed onto the serialized data stream routing unit **302A**. Similarly in the reverse path, in exemplary embodiments each electro-optical conversion module **304** is configured to receive an uplink digitized data stream in an electrical format from the serialized data stream routing unit **302A** and to convert them to an optical format for communication across a digital communication link **110** to a network interface **104**.

[0056] The serialized data stream routing unit **302A** is described in more detail below with reference to FIG. 4A. Generally in the forward path, the serialized data stream routing unit **302A** receives downlink serialized data streams for a plurality of electro-optical conversion modules **304** and aggregates a plurality of these downlink serialized data streams into at least one downlink aggregate serialized data stream that is routed to at least one electro-optical conversion module **306** (such as electro-optical conversion module **306-1**) for eventual transmission to a remote antenna unit **106**. In exemplary embodiments, the same or different downlink aggregate serialized data streams are routed to a plurality of electro-optical conversion modules **306**. In some embodiments, the serialized data stream routing unit **302A** is configured to aggregate and route data from a first subset of network interfaces **104** into a first downlink aggregate data stream that is transferred to at least a first remote antenna unit **106** and is further configured to aggregate and route data from a second subset of network interfaces **104** into a second downlink aggregate data stream that is transferred to at least a second remote antenna unit **106**. In exemplary embodiments, the first and second subsets are mutually exclusive. In other exemplary embodiments, the first and second subsets partially overlap. In other exemplary embodiments, the first and second subsets are identical. In other exemplary embodiments, data streams from greater numbers of subsets of network interfaces **104** are aggregated and communicated to greater numbers of remote antenna units **106**.

[0057] Similarly in the reverse path, the serialized data stream routing unit **302A** receives at least one uplink aggregate serialized data stream from at least one electro-optical conversion module **306** (such as electro-optical conversion module **306-1**) from a remote antenna unit **106** and splits it into a plurality of uplink serialized data streams which are passed to electro-optical conversion modules **304-1** for eventual communication to a network interface **104**. In exemplary embodiments, the same or different uplink aggregate serialized data streams are received from a plurality of electro-optical conversion modules **306**. In some embodiments, the serialized data stream routing unit **302A** is configured to receive, split apart, and route data from a first uplink aggregate data stream from at least a first remote antenna unit **106-1** to a first subset of electro-optical conversion modules **304**

destined for a first subset of network interfaces **104** and is further configured to receive, split apart, and route data from a second uplink aggregate data stream from at least a second remote antenna unit **106-2** to a second subset of electro-optical conversion modules **304** destined for a second subset of network interfaces **104**. In exemplary embodiments, the first and second subsets are mutually exclusive. In other exemplary embodiments, the first and second subsets partially overlap. In other exemplary embodiments, the first and second subsets are identical. In other exemplary embodiments, aggregate data streams from greater numbers of remote antenna units **106** are split apart and communicated to greater numbers of subsets of network interfaces **104**.

[0058] Each electro-optical conversion module **306** is communicatively coupled to a remote antenna unit **106** across a digital communication link **112**. In the forward path, each electro-optical conversion module **304** is configured to receive an aggregate downlink serialized data stream in an electrical format from the serialized data stream routing unit **302A**. Specifically, electro-optical conversion module **306-1** is configured to receive a first downlink aggregate serialized data stream in an electrical format from the serialized data stream routing unit **302A**, and optional electro-optical conversion module **306-B** is configured to receive a second downlink aggregate serialized data stream from serialized data stream routing unit **302A**. Each electro-optical conversion module **306** is configured to convert the aggregate downlink serialized data streams from electrical signals to optical signals, which are then communicated across a digital communication link **110** to a remote antenna unit **106**. Similarly, in the reverse path, in exemplary embodiments each electro-optical conversion module **304** is configured to receive an uplink aggregate digitized data stream from a remote antenna unit **106** across a digital communication link **110** in an optical format and to convert them to an electrical format for communication to the serialized data stream routing unit **302A**.

[0059] FIG. 3B is a block diagram of an exemplary distributed antenna switch **102B** including serialized data stream routing unit **302B**, electro-optical conversion modules **304**, at least one electro-optical conversion module **306**, serialized data stream to Ethernet conversion module **314**, Ethernet switch **316**, optional processor **308**, optional memory **310**, and optional power supply **312**. Distributed antenna switch **102B** includes similar components to distributed antenna switch **102A** and operates according to similar principles and methods as distributed antenna switch **102A** described above. The difference between distributed antenna switch **102B** and distributed antenna switch **102A** is that distributed antenna switch **102B** includes serialized data stream to Ethernet conversion module **314** and Ethernet switch **316**. In exemplary embodiments, serialized data stream to Ethernet conversion module **314** and/or Ethernet switch **316** are also implemented by optional processor **308** and memory **310** and optional power supply **312** also powers serialized data stream to Ethernet conversion module **314** and/or Ethernet switch **316**.

[0060] In the downlink, in exemplary embodiments serialized data stream to Ethernet conversion module **314** is configured to receive downlink data streams from the serialized data stream routing unit **302B** and to convert the downlink data streams to downlink Ethernet frames that are passed onto Ethernet switch **316** that is configured to switch and/or route downlink Ethernet frames and is configured to pass the switched and/or routed downlink Ethernet frames back to the serialized data stream to Ethernet conversion module **314** that

converts the switched and/or routed downlink Ethernet frames back to downlink data streams that are aggregated into aggregate downlink data streams as described herein. Similarly, in the uplink in exemplary embodiments serialized data stream to Ethernet conversion module **314** is configured to receive uplink data streams that have been extracted from aggregate data streams from serialized data stream routing unit **302B** and to convert the uplink data streams to uplink Ethernet frames that are passed onto Ethernet switch **316** that is configured to switch and/or route uplink Ethernet frames and is configured to pass the switched and/or routed uplink Ethernet frames back to the serialized data stream to Ethernet conversion module **314** that converts the switched and/or routed uplink Ethernet frames back to uplink data streams that are aggregated into aggregate uplink data streams as described herein.

[0061] FIGS. 4A-4B are block diagrams of exemplary embodiments of serialized data stream routing units **302** used in distributed antenna switches **102** used in distributed antennas systems, such as the exemplary distributed antenna system **100** described above. Each of FIGS. 4A-4B illustrates a different embodiment of serialized data stream routing unit **302**, labeled serialized data stream routing unit **302A-302B** respectively.

[0062] FIG. 4A is a block diagram of an exemplary data stream routing unit **302A** including serial ports **402** (including serial portion **402-1**, serial port **402-2**, and any amount of optional serial ports **402** through optional serial port **402-A**), selector/summers **404** (including selector/summer **404-1**, selector/summer **404-2**, and any amount of optional selector/summer **404** through optional selector/summer **404-A**), at least one serial port **406** (including serial port **406-1**, optional serial port **406-2**, and any amount of optional serial ports **406** through optional serial port **406-B**), at least one selector/summer **408** (including selector/summer **408-1**, optional selector/summer **408-2**, and any amount of optional selector/summers **408** through optional selector-summer **408-B**). In exemplary embodiments, selector summers **404** and at least one selector summer **408** are implemented by optional processor **308** of the distributed antenna switch **102A**.

[0063] In the forward path, each serial port **402** receives a downlink serialized data stream from a corresponding electro-optical conversion module **304** and communicates the serialized data stream to at least one selector/summer **408**. In the reverse path, each serial port **402** receives a serialized data stream from a corresponding selector/summer **404** and for output to at least one electro-optical conversion module **304**.

[0064] In the reverse path, each selector/summer **404** receives at least one serialized data stream from at least one serial port **406** and selects and/or sums serialized data streams together for output to at least one serial port **402**. In exemplary embodiments, a selector/summer **404** is configured to receive uplink aggregate serialized data streams from a plurality of serial ports **406** and to map timeslots from the plurality of aggregate upstream data streams into different timeslots on an upstream serialized data stream communicated to an associated serial port **402**. In other exemplary embodiments, a selector/summer **404** is configured to receive uplink aggregate serialized data streams from a plurality of serial ports **406** and to digitally sum data from timeslots of a plurality of aggregate serialized data streams into a single uplink data stream communicated to an associated serial port **402**. In exemplary embodiments, the data rate of one or more uplink aggregate serialized data stream received at any of serial ports



406 are different from the data rates of the uplink data streams communicated at serial ports 402. In exemplary embodiments, the data rate of an uplink aggregate serialized data stream received at a serial port 406 is greater than the data rate of a plurality of uplink serialized data streams communicated at serial ports 402, such that the uplink aggregate serialized data stream received at a serial port 406 includes data from the plurality of uplink serialized data streams communicated at serial ports 402.

[0065] In the forward path, each selector/summer 408 receives a plurality of downlink serialized data streams from a plurality of serial ports 402 and selects and/or sums the serialized data streams together for output to at least one serial port 406. In exemplary embodiments, a selector/summer 408 is configured to receive downlink serialized data streams from a plurality of serial ports 402 and to map timeslots from the plurality of aggregate downlink data streams into different timeslots on a downlink aggregate serialized data stream communicated to an associated serial port 406. In other exemplary embodiments, a selector/summer 408 is configured to receive downlink serialized data streams from a plurality of serial ports 402 and to digitally sum data from timeslots of a plurality of downlink serialized data streams into a single downlink aggregate serialized data stream communicated to an associated serial port 406. In exemplary embodiments, the data rate of the downlink data streams received at serial ports 402 are different from the data rates of one or more downlink aggregate serialized data streams received at any serial ports 406. In exemplary embodiments, the data rate of a plurality of downlink serialized data streams received at serial ports 402 is lower than the data rate of at least one downlink aggregate serialized data stream communicated at a serial port 406, such that the downlink aggregate serialized data stream communicated at a serial port 406 includes data from the plurality of downlink serialized data streams received at serial ports 402.

[0066] In the forward path, each serial port 406 receives a serialized data stream from a corresponding selector/summer 408 and outputs it to a corresponding electro-optical conversion module 306. In the reverse path, each serial port 406 receives a serialized data stream from a corresponding electro-optical conversion module 304 and communicates the serialized data stream to at least one selector/summer 404.

[0067] FIG. 4B is a block diagram of an exemplary data stream routing unit 302B including serial ports 402, selector/summers 404, at least one serial port 406, at least one selector/summer 408, and serial port 410. Serialized data stream routing unit 302B includes similar components to serialized data stream routing unit 302A and operates according to similar principles and methods as serialized data stream routing unit 302A described above. The difference between data stream routing unit 302B and data stream routing unit 302A is that data stream routing unit 302B includes serial port 410 communicatively coupled to the serial port 410. Serial port 410 is communicatively coupled to serial ports 402 and is configured to receive downlink serialized data streams from serial ports 402. Serial port 410 is further communicatively coupled to at least one selector/summer 408 and is configured to communicate downlink serialized data streams to at least one selector/summer 408. Serial port 410 is further communicatively coupled to at least one serial port 406 and receives at least one uplink aggregate serialized data stream from the at least one serial port 406. Serial port 410 is further communicatively coupled to at least one selector/summer 404 and is configured to communicate uplink serialized data streams to

selector/summers 404. Serial port 410 is configured to communicate serialized data streams to and from the serialized baseband to Ethernet conversion module 414. Thus, serialized data streams containing Ethernet frames can be passed through to Ethernet switch for switching of the Ethernet frames and then returned to the serialized baseband routing unit for routing to various destinations.

[0068] FIGS. 5A-5B are block diagrams of exemplary embodiments of remote antenna units 106 used in distributed antenna systems, such as the exemplary distributed antenna system 100 described above. Each of FIGS. 5A-5B illustrates a different embodiment of remote antenna unit 106, labeled remote antenna unit 106A-106B respectively.

[0069] FIG. 5A is a block diagram of an exemplary remote antenna unit 106 including serialized data stream multiplexing unit 502, at least one radio frequency (RF) conversion module 504 (including RF conversion module 504-1 and any amount of optional RF conversion modules 504 through optional conversion module 504-C), optional electro-optical conversion module 506, optional Ethernet interface 508, optional processor 510, optional memory 512, and optional power supply 514. In exemplary embodiments, serialized data stream multiplexing unit 502 and/or RF conversion modules 504 are implemented at least in part by optional processor 510 of the remote antenna unit 106A. In exemplary embodiments, the exemplary remote antenna unit 106A includes optional power supply 514 to power the serialized data stream multiplexing unit 502, the at least one RF conversion module 504, the optional electro-optical conversion module 506, the optional Ethernet interface 508 and the optional processor 510 and memory 512.

[0070] The electro-optical conversion module 506 is communicatively coupled to the distributed antenna switch 102 across a digital communication link 112. In the forward path, the electro-optical conversion module 506 is configured to receive a downlink aggregate digitized data stream from the distributed antenna switch 102 across a digital communication link 112. The electro-optical conversion module 506 is configured to convert the downlink aggregate digitized data stream from optical to electrical signals, which are then passed onto the serialized data stream multiplexing unit 502. Similarly in the reverse path, in exemplary embodiments the electro-optical conversion module 506 is configured to receive an uplink aggregate digitized data stream in an electrical format from the serialized data stream multiplexing unit 502 and to convert the uplink aggregate digitized data stream to an optical format for communication across the digital communication link 112 to the distributed antenna switch 102. In exemplary embodiments more than one electro-optical conversion module 506 is coupled across more than one digital communication link 112 to the same distributed antenna switch 102, an intermediary device, and/or another distributed antenna switch 102.

[0071] The serialized data stream multiplexing unit 502 is described in more detail below with reference to FIG. 6. Generally in the forward path, the serialized data stream multiplexing unit 502 is configured to receive a downlink aggregate serialized data stream from the electro-optical conversion module 506 and configured to split apart the individual downlink serialized data streams from the downlink aggregate data stream and is further configured to communicate the individual downlink serialized data streams to various RF conversion modules 504 and/or one or more Ethernet interface 504. In exemplary embodiments, one of the indi-

vidual downlink serialized data streams contains data pertaining to a first mobile access band and/or technology while another individual downlink serialized data streams contains data pertaining to a second mobile access band and/or technology. In exemplary embodiments, one of the downlink serialized data streams contains Ethernet frames for the Ethernet interface 508. In other example embodiments, other types of data is carried in the downlink serialized data streams.

[0072] Similarly in the reverse path, the serialized data stream multiplexing unit 502 is configured to receive individual uplink serialized data streams from various RF conversion modules 504, further configured to aggregate the individual uplink serialized data streams into an uplink aggregate data stream, and further configured to communicate the uplink aggregate data stream to the electro-optical conversion module 506 for eventual communication to the distributed antenna switch 102 across the digital communication link 112.

[0073] Each RF conversion module 504 is communicatively coupled to the serialized data stream multiplexing unit 502 and is coupled to and/or includes at least one antenna 114. Each RF conversion module 504 is configured to convert between at least one downlink serialized data stream and radio frequency signals in at least one radio frequency band. Each RF conversion module is configured to communicate radio frequency signals in the at least one radio frequency band across an air medium with at least one subscriber using at least one antenna 114.

[0074] In the downstream, each RF conversion module 504 is configured to convert at least one downlink serialized data stream into a downlink radio frequency (RF) signal in a radio frequency band. In exemplary embodiments, this may include digital to analog converters and oscillators. Each RF conversion module 504 is further configured to transmit the downlink radio frequency signal in the radio frequency band to at least one subscriber unit using at least one radio frequency transceiver and antenna 114 pair. In a specific embodiment, radio frequency conversion module 504-1 is configured to convert at least one downlink serialized data stream into a downlink radio frequency signal in a radio frequency band. Each RF conversion module 504 is further configured to transmit the downlink radio frequency signal in a radio frequency band using a radio frequency and antenna 114-1 pair to at least one wireless subscriber unit. In exemplary embodiments, radio frequency conversion module 504-1 is configured to convert a first downlink serialized data stream into a first downlink radio frequency signal in a first radio frequency band and to transmit the first downlink radio frequency signal in the first radio frequency band to at least one wireless subscriber unit using the antenna 114-1. Similarly, radio frequency conversion module 504-2 is configured to convert a second downlink serialized data stream into a second downlink radio frequency signal in a second radio frequency band and to transmit the second downlink radio frequency signal in the second radio frequency band to at least one wireless subscriber unit using the antenna 114-2. In exemplary embodiments, one radio frequency conversion module 504-1 and antenna pair 114-1 transports to a first set of wireless subscriber units in a first band and another radio frequency conversion module 504-C and antenna pair 114-C transports to a second set of wireless subscriber units in a second band. Other combinations of radio frequency conversion module 504 and antenna 114 pairs are used to communication other

combinations of radio frequency signals in other various radio frequency bands to various subscriber units

[0075] Similarly in the reverse path, in exemplary embodiments each RF conversion module 504 is configured to receive uplink radio frequency signals from at least one subscriber unit using at least one radio frequency antenna 114. Each radio frequency conversion module 504 is further configured to convert the radio frequency signals to at least one uplink serialized data stream. Each radio frequency conversion module 504 is further configured to communicate the uplink serialized data stream to the serialized data stream multiplexing unit 502.

[0076] FIG. 5B is a block diagram of an exemplary remote antenna unit 106B including serialized data stream multiplexing unit 502, a plurality of radio frequency (RF) conversion modules 504 (including RF conversion modules 504-1 through 504-8), optional electro-optical conversion module 506, an Ethernet interface 508, optional processor 510, optional memory 512, and optional power supply 514. Remote antenna unit 106B includes similar components to remote antenna unit 106A and operates according to similar principles and methods as remote antenna unit 106A described above. The difference between remote antenna unit 106B and remote antenna unit 106A is that remote antenna unit 106B includes eight RF conversion modules 504-1 through 504-8 coupled to antennas 114-1 through 114-8 respectively and an Ethernet interface 508. In exemplary embodiments, serialized data stream multiplexing unit 502 and/or RF conversion modules 504 are implemented at least in part by optional processor 510 of the remote antenna unit 106B. In exemplary embodiments, the exemplary remote antenna unit 106A includes optional power supply 514 to power the serialized data stream multiplexing unit 502, the RF conversion modules 504, the optional electro-optical conversion module 506, the Ethernet interface 508 and the optional processor 510 and memory 512.

[0077] FIGS. 6A-6B are block diagrams of exemplary embodiments of serialized baseband multiplexing units 502 of remote antenna units 106 used in distributed antenna systems, such as the exemplary distributed antenna system 100 described above. Each of FIGS. 6A-6B illustrates a different embodiment of serialized baseband multiplexing units 502, labeled serialized baseband multiplexing unit 502A-502B respectively.

[0078] FIG. 6A is a block diagram of an exemplary serialized baseband multiplexing unit 502A including at least one serial port 602 (including serial port 602-1), at least one frame multiplexer 604 (including frame multiplexer 604-1), at least one frame de-multiplexer 606 (including frame de-multiplexer 606-1), at least one serial port 608 (including serial port 608-1 and any number of optional serial ports 608 through optional serial port 608-C), and optional serial port 610. In exemplary embodiments, the at least one frame multiplexer 604 and the at least one frame de-multiplexer 608 are implemented at least in part by optional processor 510 of remote antenna unit 106A.

[0079] The serial port 602-1 is communicatively coupled to an electro-optical conversion module 506. In the forward path, serial port 602-1 receives at least one downlink aggregate serialized data stream in electrical format from the electro-optical conversion module 506 and passes it to the frame de-multiplexer 606-1. In the reverse path, serial port 602-1 receives at least one uplink aggregate serialized data stream

from the frame multiplexer **604-1** and passes it to the electro-optical conversion module **506**.

**[0080]** The frame de-multiplexer **606-1** is communicatively coupled to both the serial port **602-1** and at least one serial port **608**. In the forward path, the frame de-multiplexer **606-1** separates at least one downlink serialized data stream from the at least one downlink aggregate serialized data stream and passes it to the serial port **608-1** or optional serial port **610**. In exemplary embodiments, the frame de-multiplexer **606-1** separates a plurality of downlink serialized data streams from the at least one downlink aggregate serialized data stream and passes them onto respective serial ports **608**, such as serial port **608-1**, optional serial port **608-2** through optional serial port **608-C**, and optional serial port **610**.

**[0081]** The frame multiplexer **604-1** is communicatively coupled to both the serial port **602-1** and at least one serial port **608**. In the reverse path, the frame multiplexer **604-1** aggregates at least one uplink serialized data stream received from at least one serial port **608** or optional serial port **610** into an uplink aggregate serialized data stream and passes it to the serial port **602-1**. In exemplary embodiments, the frame multiplexer **604-1** aggregates a plurality of uplink serialized data streams received from a plurality of serial ports **608** and/or optional serial port **610** and passes them onto serial port **602-1**.

**[0082]** Each of at least one port **608** are communicatively coupled to at least one RF conversion module **504**. Specifically, serial port **608-1** is communicatively coupled to RF conversion module **504-1**, optional serial port **608-1** is communicatively coupled to RF conversion module **504-2**, and optional serial port **608-C** is communicatively coupled to RF conversion module **504-C**. In the forward path, each of serial ports **608** receives a downlink serialized data stream from frame de-multiplexer **606-1** and communicates it to a respective RF conversion module **504**. In the reverse path, each of serial ports **608** receives an uplink serialized data stream from a respective RF conversion module **504** and passes it onto frame multiplexer **604-1**.

**[0083]** Optional serial port **610** is communicatively coupled to Ethernet interface **508**. In the forward path, optional serial port **610** receives a downlink serialized data stream from frame de-multiplexer **606-1** and communicates it to the Ethernet interface **508**. In the reverse path, optional serial port **610** receives an uplink serialized data stream from Ethernet interface **510** and communicates it to the frame multiplexer **604-1**.

**[0084]** FIG. **6B** is a block diagram of an exemplary serialized baseband multiplexing unit **502B** including at least one serial port **602** (including serial port **602-1**), at least one summer **612** (including summer **612-1**), at least one simulcaster **614** (including simulcaster **614-1**), at least one serial port **608** (including serial port **608-1** and any number of optional serial ports **608** through optional serial port **608-C**), and optional serial port **610**. In exemplary embodiments, the at least one summer **612** and the at least one simulcaster **614** are implemented at least in part by optional processor **510** of remote antenna unit **106B**.

**[0085]** The serial port **602-1** is communicatively coupled to an electro-optical conversion module **506**. In the forward path, serial port **602-1** receives at least one downlink aggregate serialized data stream in electrical format from the electro-optical conversion module **506** and passes it to the frame de-multiplexer **606-1**. In the reverse path, serial port **602-1** receives at least one uplink aggregate serialized data stream

from the frame multiplexer **604-1** and passes it to the electro-optical conversion module **506**.

**[0086]** The simulcaster **614-1** is communicatively coupled to both the serial port **602-1** and at least one serial port **608**. In the forward path, the simulcaster **614-1** simulcasts at least one downlink serialized data stream from the at least one downlink aggregate serialized data stream and passes it to the serial port **608-1** or optional serial port **610**. In exemplary embodiments, the simulcaster **614-1** simulcasts a plurality of downlink serialized data streams from the at least one downlink aggregate serialized data stream to a plurality of serial ports **608** and/or optional serial port **610**.

**[0087]** The summer **612-1** is communicatively coupled to both the serial port **602-1** and at least one serial port **608**. In the reverse path, the summer **612-1** digitally sums at least one uplink serialized data stream received from at least one serial port **608** or optional serial port **610** into an uplink aggregate serialized data stream and passes it to the serial port **602-1**. In exemplary embodiments, the summer **612-1** sums a plurality of uplink serialized data streams received from a plurality of serial ports **608** and/or optional serial port **610** and passes them onto serial port **602-1**.

**[0088]** Each of at least one port **608** are communicatively coupled to at least one RF conversion module **504**. Specifically, serial port **608-1** is communicatively coupled to RF conversion module **504-1**, optional serial port **608-1** is communicatively coupled to RF conversion module **504-2**, and optional serial port **608-C** is communicatively coupled to RF conversion module **504-C**. In the forward path, each of serial ports **608** receives a downlink serialized data stream from simulcaster **614-1** and communicates it to a respective RF conversion module **504**. In the reverse path, each of serial ports **608** receives an uplink serialized data stream from a respective RF conversion module **504** and passes it onto summer **612-1**.

**[0089]** Optional serial port **610** is communicatively coupled to Ethernet interface **508**. In the forward path, optional serial port **610** receives a downlink serialized data stream from simulcaster **614-1** and communicates it to the Ethernet interface **508**. In the reverse path, optional serial port **610** receives an uplink serialized data stream from Ethernet interface **510** and communicates it to the summer **612-1**.

**[0090]** FIGS. **7A-7C** are block diagrams of exemplary embodiments of RF conversion modules of remote antenna units **106** used in distributed antenna systems, such as the exemplary distributed antenna system **100** described above. Each of FIGS. **7A-7C** illustrates a different embodiment of RF conversion module **504**, labeled RF conversion module **504A-504C** respectively.

**[0091]** FIG. **7A** is a block diagram of an exemplary RF conversion module **504A** including an optional serialized data stream conditioner **702**, an RF frequency converter **704**, an optional RF conditioner **706**, and an RF duplexer **708** coupled to a single antenna **114**.

**[0092]** The optional serialized data stream conditioner **702** is communicatively coupled to a remote serialized data stream unit **502** and the radio frequency (RF) converter **704**. In the forward path, the optional serialized data stream conditioner **702** conditions the downlink serialized data stream (for example, through amplification, attenuation, and filtering) received from the remote serialized data stream unit **502** and passes the downlink serialized data stream to the RF converter **704**. In the reverse path, the optional serialized data stream conditioner **702** conditions the uplink serialized data

stream (for example, through amplification, attenuation, and filtering) received from the RF converter 704 and passes the uplink serialized data stream to the remote serialized data stream unit 502.

[0093] The RF converter 704 is communicatively coupled to either the remote serialized data stream unit 502 or the optional serialized data stream conditioner 702 on one side and to either RF duplexer 708 or the optional RF conditioner 706 on the other side. In the downstream, the RF converter 704 converts a downlink serialized data stream to downlink radio frequency (RF) signals and passes the downlink RF signals onto either the RF duplexer 708 or the optional RF conditioner 706. In the upstream, the RF converter 704 converts uplink radio frequency (RF) signals received from either the RF duplexer 708 or the optional RF conditioner 706 to an uplink serialized data stream and passes the uplink serialized data stream to either the remote serialized data stream unit 502 or the optional serialized data stream conditioner 702.

[0094] The RF duplexer 708 is communicatively coupled to either the RF frequency converter 704 or the optional RF conditioner 706 on one side and the antenna 114 on the other side. The RF duplexer 708 duplexes the downlink RF signals with the uplink RF signals for transmission/reception using the antenna 114.

[0095] FIG. 7B is a block diagram of an exemplary RF conversion module 504B including an optional serialized data stream conditioner 702, an RF frequency converter 704, and an optional RF conditioner 706 coupled to a downlink antenna 114A and an uplink antenna 114B. RF conversion module 504B includes similar components to RF conversion module 504A and operates according to similar principles and methods as RF conversion module 504A described above. The difference between RF conversion module 504B and RF conversion module 504A is that RF conversion module 504B does not include RF duplexer 708 and instead includes separate downlink antenna 114A used to transmit RF signals to at least one subscriber unit and uplink antenna 114B used to receive RF signals from at least one subscriber unit.

[0096] FIG. 7C is a block diagram of an exemplary RF conversion module 504C-1 and exemplary RF conversion module 504C-2 that share a single antenna 114 through an RF diplexer 710. The RF conversion module 504C-1 includes an optional serialized data stream conditioner 702-1, an RF frequency converter 704-1, an optional RF conditioner 706-1, and an RF duplexer 708-1 communicatively coupled to RF diplexer 710 that is communicatively coupled to antenna 114. Similarly, the RF conversion module 504C-2 includes an optional serialized data stream conditioner 702-2, an RF frequency converter 704-2, an optional RF conditioner 706-2, and an RF duplexer 708-2 communicatively coupled to RF diplexer 710 that is communicatively coupled to antenna 114. Each of RF conversion module 504C-1 and 504C-2 operate according to similar principles and methods as RF conversion module 504A described above. The difference between RF conversion modules 504C-1 and 504C-2 and RF conversion module 504A is that RF conversion modules 504C-1 and 504C-2 are both coupled to a single antenna 114 through RF diplexer 710. The RF diplexer 710 duplexes the duplexed downlink and uplink signals for both RF conversion module 504C-1 and 504C-2 for transmission/reception using the single antenna 114.

[0097] FIG. 8A-8B are block diagrams depicting exemplary embodiments of Ethernet interface 508 of remote antenna units 106 used in distributed antenna systems, such as

exemplary distributed antenna system 100 described above. Each of FIGS. 8A-8B illustrates a different embodiment of an Ethernet interface 508A, labeled 508A-508B respectively.

[0098] FIG. 8A is a block diagram of an exemplary embodiment of an Ethernet interface 508, Ethernet interface 508A. Ethernet interface 508A includes a serialized data stream to Ethernet conversion module 802 communicatively coupled to a remote serialized data stream unit 502 and an Ethernet device 804A and acts as the interface between the remote serialized data stream unit 502 and the Ethernet device 804A. In the forward path, the serialized data stream to Ethernet conversion module 802 converts a downlink serialized data stream received from the remote serialized data stream unit 502 to downlink Ethernet frames and communicates the downlink Ethernet frames to the Ethernet device 804A. In the reverse path, the serialized data stream to Ethernet conversion module 802 converts uplink Ethernet frames received from the Ethernet device 804A to an uplink serialized data stream and communicates the uplink serialized data stream to the remote serialized data stream unit 502. In exemplary embodiments, the Ethernet device 804A interfaces with an internet protocol network.

[0099] FIG. 8B is a block diagram of an exemplary embodiment of an Ethernet interface, Ethernet interface 508B. Ethernet interface 508B includes a serialized data stream to Ethernet conversion module 802 communicatively coupled to a remote serialized data stream unit 502 and a wifi access point 804B and acts as the interface between the remote serialized data stream unit 502 and a wifi access point 804B. Ethernet interface 508B includes similar components to Ethernet interface 508A and operates according to similar principles and methods as Ethernet interface 508A described above. The difference between Ethernet interface 508B and Ethernet interface 508A is that Ethernet interface 508B interfaces with wifi access point 804B specifically instead of an Ethernet device 804A generally.

[0100] FIGS. 9A-9C are block diagrams of embodiments of additional exemplary distributed antenna systems 900 using serial link interface units 902 positioned between the network interfaces 104 and the distributed antenna switch 102. Each of FIGS. 9A-9C illustrates a different embodiment of a distributed antenna system 900, labeled 900A-900C respectively.

[0101] FIG. 9A is a block diagram of an exemplary embodiment of a distributed antenna system 900, labeled distributed antenna system 900A. Distributed antenna system 900A includes a plurality of network interfaces 104 communicatively coupled to external devices 108 and to a serial link interface unit 902-1 across digital communication links 110. Serial link interface unit 902-1 is communicatively coupled to distributed antenna switch 102 across digital communication link 904-1. Optional network interface 104-H is communicatively coupled to an external device 108-H and to distributed antenna switch 102 across optional digital communication link 110-H. Distributed antenna switch 102 is communicatively coupled to at least one remote antenna unit 106 across at least one digital communication link 112. The at least one remote antenna unit 106 is communicatively coupled to at least one antenna 114. Distributed antenna system 900A includes similar components to distributed antenna system 100 and operates according to similar principles and methods as distributed antenna system 100. The difference between distributed antenna system 100 and distributed antenna system 900A is the inclusion of serial link interface unit 902-1.

[0102] In the forward path, serial link interface unit **902-1** aggregates downlink serialized data streams from a plurality of network interfaces **104** into a first aggregate downlink serialized data stream that it passes to distributed antenna switch **102** over digital communication link **102**. Distributed antenna switch can then selectively aggregate downlink serialized data streams from the first aggregate downlink serialized data stream with any downlink serialized data streams from optional network interfaces **104** into at least a second aggregate downlink serialized data stream that it passes to remote antenna unit **106-1**. In exemplary embodiments, distributed antenna switch can aggregate other sets of downlink serialized data streams into a third aggregate downlink serialized data stream that it passes to remote antenna unit **106-1**. In the reverse path, distributed antenna switch **102** separates an aggregate uplink serialized data stream from remote antenna unit **106-1** into a plurality of uplink serialized data streams and passes at least some of the plurality of uplink serialized data streams to the serial link interface unit **902-1** that can separate at least one of the uplink serialized data streams into a plurality of uplink serialized data streams that are passed onto a plurality of network interfaces **104**. The remainder of distributed antenna system **900A** may operate similarly to distributed antenna system **100** described above.

[0103] FIG. 9B is a block diagram of an exemplary embodiment of a distributed antenna system **900**, labeled distributed antenna system **900B**. Distributed antenna system **900B** includes a plurality of network interfaces **104** communicatively coupled to external devices **108** and to a plurality of serial link interface units **902**. The plurality of serial link interface units **902** are communicatively coupled to the plurality of network interfaces and a distributed antenna switch **102**. The distributed antenna switch **102** is coupled to at least one remote antenna unit **106**. Distributed antenna system **900B** includes similar components to distributed antenna system **900A** and operates according to similar principles and methods as distributed antenna system **900A**. The difference between distributed antenna system **900B** and distributed antenna system **900A** is that distributed antenna system **900B** includes a plurality of serial link interface units **902**. Each of the plurality of serial link interface units operate as described above with reference to serial link interface unit **902-1** and further described below.

[0104] FIG. 9C is a block diagram of an exemplary embodiment of a distributed antenna system **900**, labeled distributed antenna system **900C**. Distributed antenna system **900C** includes a plurality of network interfaces **104** communicatively coupled to external devices **108** and to a plurality of serial link interface units **902**. The plurality of serial link interface units **902** are communicatively coupled to the plurality of network interfaces and a serial link interface unit **902-2**. The serial link interface unit **902-2** is communicatively coupled to the plurality of serial link interface units **902** and to the distributed antenna switch **102**. Distributed antenna system **900C** includes similar components to distributed antenna system **900B** and operates according to similar principles and methods as distributed antenna system **900B**. The difference between distributed antenna system **900C** and distributed antenna system **900B** is that distributed antenna system **900B** includes cascaded serial link interface units **902** with serial link interface unit **902-2**. In other embodiments, more serial link interface units **902** are cascaded. The cascading allows, among other enhancements, to include lower data rate network interfaces to be aggregated into higher data rate aggreg-

ate signals that are communicated to the distributed antenna switch. Each of the plurality of serial link interface units operate as described above with reference to serial link interface unit **902-1** and further described below.

[0105] FIGS. 10A-10D are block diagrams of serial link interface units **902** used in distributed antenna systems, such as the exemplary distributed antenna systems **900A-900C**. Each of FIGS. 10A-10D illustrates a different embodiment of a serial link interface unit **902**, labeled **902A-902D** respectively.

[0106] FIG. 10A is a block diagram of a serial link interface unit **902**, labeled serial link interface unit **902A**. Serial link interface unit **902A** includes a plurality of serial ports **1002** (including serial port **1002-1**, serial port **1002-2**, and any optional serial port **1002** through serial port **1002-L**), a serial port **1004-1**, a frame multiplexer **1006**, and a frame de-multiplexer **1008**. In the forward path, each serial port **1002** receives a downlink serialized data stream from an electro-optical conversion module **1010** and passes it to the frame multiplexer **1006**. Frame multiplexer multiplexes the downlink serialized data streams received from each serial port **1002** into a downlink aggregate serialized data stream and passes it to serial port **1004-1**. Serial port **1004-1** receives the downlink aggregate serialized data stream and passes it to an electro-optical conversion module **1012-1**. In the reverse path, the serial port **1004-1** receives an uplink aggregate serialized data stream from an electro-optical conversion module **1012-1** and passes it to the frame de-multiplexer **1008**. The frame de-multiplexer **1008** separates the uplink aggregate serialized data stream into a plurality of uplink serialized data stream and passes them to respective serial ports **1002**.

[0107] FIG. 10B is a block diagram of a serial link interface unit **902**, labeled serial link interface unit **902B**. Serial link interface unit **902B** includes a plurality of serial ports **1002** (including serial port **1002-1**, serial port **1002-2**, and any optional serial port **1002** through serial port **1002-L**), a serial port **1004-1**, a summer **1014**, and a simulcaster **1016**. In the forward path, each serial port **1002** receives a downlink serialized data stream from an electro-optical conversion module **1010** and passes it to the summer **1014**. Summer **1014** sums the downlink serialized data streams received from each serial port **1002** into a downlink aggregate serialized data stream and passes it to serial port **1004-1**. Serial port **1004-1** receives the downlink aggregate serialized data stream and passes it to an electro-optical conversion module **1012-1**. In the reverse path, the serial port **1004-1** receives an uplink aggregate serialized data stream from an electro-optical conversion module **1012-1** and passes it to the simulcaster **1016**. The simulcaster **1016** simulcasts the uplink aggregate serialized data stream to the plurality of serial ports **1002**.

[0108] FIG. 10C is a block diagram of a serial link interface unit **902**, labeled serial link interface unit **902C**. Serial link interface unit **902C** includes a plurality of serial ports **1002** (including serial port **1002-1**, serial port **1002-2**, and any optional serial port **1002** through serial port **1002-L**), a plurality of serial ports **1004** (including serial port **1004-1** through serial port **1004-M**), a summer **1014**, and a simulcaster **1016**. In the forward path, each serial port **1002** receives a downlink serialized data stream from an electro-optical conversion module **1010** and passes it to the summer **1014**. Similarly, the serial port **1004-M** receives a downlink serialized data stream from an electro-optical conversion module **1012-M** and passes it to the summer **1014**. Summer

**1014** sums the downlink serialized data streams received from each serial port **1002** and the serial port **1004-M** into a downlink aggregate serialized data stream and passes it to serial port **1004-1**. Serial port **1004-1** receives the downlink aggregate serialized data stream and passes it to an electro-optical conversion module **1012-1**. In the reverse path, the serial port **1004-1** receives an uplink aggregate serialized data stream from an electro-optical conversion module **1012-1** and passes it to the simulcaster **1016**. The simulcaster **1016** simulcasts the uplink aggregate serialized data stream to the plurality of serial ports **1002** and the serial port **1004-M**.

[0109] FIG. 10D is a block diagram of a serial link interface unit **902**, labeled serial link interface unit **902D**. Serial link interface unit **902D** includes a plurality of serial ports **1002** (including serial port **1002-1**, serial port **1002-2**, and any optional serial port **1002** through serial port **1002-L**), a plurality of serial ports **1004** (including serial port **1004-1** through serial port **1004-M**), a frame multiplexer **1006**, a frame de-multiplexer **1008**, a summer **1014**, and a simulcaster **1016**. In the forward path, each serial port **1002** receives a downlink serialized data stream from an electro-optical conversion module **1010** and passes it to the frame multiplexer **1006**. Frame multiplexer multiplexes the downlink serialized data streams received from each serial port **1002** into a downlink aggregate serialized data stream and passes it to summer **1014**. The serial port **1004-M** receives a downlink serialized data stream from an electro-optical conversion module **1012-M** and passes it to the summer **1014**. Summer **1014** sums the aggregate downlink serialized data stream received from the frame multiplexer **1006** with the downlink serialized data stream received from the serial port **1004-M** into a second downlink aggregate serialized data stream and passes it to serial port **1004-1**. Serial port **1004-1** receives the second downlink aggregate serialized data stream and passes it to an electro-optical conversion module **1012-1**. In the reverse path, the serial port **1004-1** receives an uplink aggregate serialized data stream from an electro-optical conversion module **1012-1** and passes it to the simulcaster **1016**. The simulcaster **1016** simulcasts the uplink aggregate serialized data stream to the frame de-multiplexer **1008** and the serial port **1004-M**. The frame de-multiplexer **1008** separates the uplink aggregate serialized data stream into a plurality of uplink serialized data stream and passes them to respective serial ports **1002**.

[0110] FIG. 11A-11D are block diagrams showing timeslot mapping in the serial link interfaces of FIGS. 10A-10D. Each of FIGS. 11A-11D illustrates a different embodiments of the timeslot mapping in the serial link interface of the corresponding FIGS. 10A-10D.

[0111] FIG. 11A is a block diagram showing timeslot mapping in the serial link interface **902A**. Data streams **1102** (including data stream **1102-1**, data stream **1102-2**, and any amount of optional data streams **1102** through optional data stream **1102-L**) each include a plurality of timeslots. For example, data stream **1102-1** includes timeslots 0A, 1A, 2A, 3A, 4A, 5A, 6A, 7A, 8A, 9A, 10A, and 11A. Similarly, data stream **1102-2** includes timeslots 0B, 1B, 2B, 3B, 4B, 5B, 6B, 7B, 8B, 9B, 10B, and 11B. Other data streams include similar timeslots. In other embodiments, different amounts of timeslots are included in each data stream **1102**. Data stream **1104-1** is an aggregate data stream includes a plurality of clusters organized such that the timeslots from all the data streams **1102** are mapped into timeslot clusters so that all of the first timeslots come first, then the second timeslots, etc.

Specifically, cluster 0 includes timeslot 0 from each of the data streams **1102**, such that cluster 0 includes timeslots 0A, 0B, etc. Cluster 1 includes timeslot 1 from each of the data streams **1102**, such that cluster 1 includes timeslot 1A, 1B, etc. The clusters continue accordingly. This mapping generally applies in both the forward path to downlink serialized data streams and in the reverse path to uplink serialized data streams.

[0112] FIG. 11B is a block diagram showing timeslot mapping in the serial link interface **902B**. Data streams **1102** (including data stream **1102-1**, data stream **1102-2**, and any amount of optional data streams **1102** through optional data stream **1102-L**) and data stream **1104** are aggregate data streams and each include a plurality of clusters organized such that the timeslots from a plurality of data streams are mapped into the timeslot clusters so that all of the first timeslots come first, then the second timeslots, etc. Specifically, cluster 0 includes timeslot 0 from each of the data streams **1102**, such that cluster 0 includes timeslots 0A, 0B, etc. Cluster 1 includes timeslot 1 from each of the data streams **1102**, such that cluster 1 includes timeslot 1A, 1B, etc. The clusters continue accordingly. This mapping generally applies in both the forward path to downlink serialized data streams and in the reverse path to uplink serialized data streams.

[0113] FIG. 11C is a block diagram showing timeslot mapping in the serial link interface **902C**. The timeslot mapping in FIG. 11C is similar to the timeslot mapping in FIG. 11B with the difference that additional data stream **1104-N** is an aggregate data stream that includes a plurality of clusters organized so that all of the first timeslots come first, then the second timeslots, etc. as with aggregate data stream **1104-1**.

[0114] FIG. 11D is a block diagram showing timeslot mapping in the serial link interface **902D**. The timeslot mapping in FIG. 11D is similar to the timeslot mapping in FIG. 11A with the difference that additional data stream **1104-N** is an aggregate data stream that includes a plurality of clusters organized so that all of the first timeslots come first, then the second timeslots, etc. as with aggregate data stream **1104-1**.

[0115] FIGS. 12A-12C are block diagrams of embodiments of additional exemplary distributed antenna systems **900** using serial link interface units **1202** positioned between the distributed antenna switch **102** and the at least one remote antenna unit **106**. Each of FIGS. 12A-12C illustrates a different embodiment of a distributed antenna system **1200**, labeled **1200A-1200C** respectively.

[0116] FIG. 12A is a block diagram of an exemplary embodiment of a distributed antenna system **1200**, labeled distributed antenna system **1200A**. Distributed antenna system **1200A** includes a plurality of network interfaces **104** communicatively coupled to external devices **108** and to distributed antenna switch **102** across digital communication links **110**. Distributed antenna switch **102** is communicatively coupled to serial link interface unit **1202-1** through digital communication link **1204-1**. Serial link interface unit is communicatively coupled to at least one remote antenna unit **106** across at least one digital communication link **112**. The at least one remote antenna unit **106** is communicatively coupled to at least one antenna **114**. Distributed antenna system **1200A** includes similar components to distributed antenna system **100** and operates according to similar principles and methods as distributed antenna system **100**. The

difference between distributed antenna system **100** and distributed antenna system **1200A** is the inclusion of serial link interface unit **1202-1**.

[0117] In the forward path, serial link interface unit **902-1** receives an aggregate downlink serialized data stream and either simulcasts the aggregate downlink serialized data stream to the at least one remote antenna unit **106-1** or separates the aggregate downlink serialized data stream into a plurality of downlink serialized data streams and communicates one of the plurality of downlink serialized data streams to the at least one remote antenna unit **106-1**. In exemplary embodiments, the serial link interface unit **1202-1** simulcasts the aggregate downlink serialized data stream to a plurality of remote antenna units **106**. In other exemplary embodiments, the serial link interface unit **1202** separates the aggregate downlink serialized data stream into a plurality of downlink serialized data streams and communicates each of the plurality of downlink serialized data stream to a different remote antenna unit **106**. In the reverse path, serial link interface unit **1202-1** receives uplink serialized data streams from at least one remote antenna unit **106**. In exemplary embodiments, the serial link interface unit **1202-1** aggregates a plurality of uplink serialized data streams at a lower data rate into a single aggregate data stream at a higher data rate and passes that to the distributed antenna switch **102**. In other exemplary embodiments, the serial link interface unit **1202-1** sums a plurality of uplink serialized data streams into a single aggregate data stream and passes that to the distributed antenna switch **102**. The remainder of distributed antenna system **900A** may operate similarly to distributed antenna system **100** described above.

[0118] FIG. **12B** is a block diagram of an exemplary embodiment of a distributed antenna system **1200**, labeled distributed antenna system **1200B**. Distributed antenna system **1200B** includes a plurality of network interfaces **104** communicatively coupled to external devices **108** and to a distributed antenna switch **102**. The distributed antenna switch **102** is coupled to a plurality of serial link interface units **1202**. The plurality of serial link interface units **1202** are communicatively coupled to the distributed antenna switch **102** and at least one remote antenna unit **106** each. Distributed antenna system **1200B** includes similar components to distributed antenna system **1200A** and operates according to similar principles and methods as distributed antenna system **1200A**. The difference between distributed antenna system **1200B** and distributed antenna system **1200A** is that distributed antenna system **1200B** includes a plurality of serial link interface units **1202**. Each of the plurality of serial link interface units operate as described above with reference to serial link interface unit **1202-1** and further described below.

[0119] FIG. **12C** is a block diagram of an exemplary embodiment of a distributed antenna system **1200**, labeled distributed antenna system **1200C**. Distributed antenna system **1200C** includes a plurality of network interfaces **104** communicatively coupled to external devices **108** and to a distributed antenna switch **102**. The distributed antenna switch **102** is communicatively coupled to a serial link interface unit **1202-2**. The serial link interface unit **1202-2** is communicatively coupled to a plurality of serial link interface units **1202**. The plurality of serial link interface units **1202** are communicatively coupled to at least one remote antenna unit **106** each.

[0120] Distributed antenna system **1200C** includes similar components to distributed antenna system **1200B** and oper-

ates according to similar principles and methods as distributed antenna system **1200B**. The difference between distributed antenna system **1200C** and distributed antenna system **1200B** is that distributed antenna system **1200B** includes cascaded serial link interface units **1202** with serial link interface unit **1202-2**. In other embodiments, more serial link interface units **1202** are cascaded. The cascading allows, among other enhancements, to include lower data rate remote antenna units to be aggregated into higher data rate aggregate signals that are communicated to the distributed antenna switch. Each of the plurality of serial link interface units operate as described above with reference to serial link interface unit **1202-1** and further described below.

[0121] FIGS. **13A-13D** are block diagrams of serial link interface units **1202** used in distributed antenna systems, such as the exemplary distributed antenna systems **1200A-1200C**. Each of FIGS. **13A-13D** illustrates a different embodiment of a serial link interface unit **1202**, labeled **1302A-1302D** respectively.

[0122] FIG. **13A** is a block diagram of a serial link interface unit **1202**, labeled serial link interface unit **1202A**. Serial link interface unit **1202A** includes a serial port **1302-1**, a plurality of serial ports **1304** (including serial port **1304-1**, serial port **1304-2**, and any optional serial port **1304** through serial port **1304-W**), a frame multiplexer **1306**, and a frame de-multiplexer **1308**. In the forward path, the serial port **1302-1** receives a downlink aggregate serialized data stream from an electro-optical conversion module **1310-1** and passes it to the frame de-multiplexer **1308**. The frame de-multiplexer **1308** separates the downlink aggregate serialized data stream into a plurality of downlink serialized data stream and passes them to respective serial ports **1304**. In the reverse path, each serial port **1304** receives an uplink serialized data stream from an electro-optical conversion module **1312** and passes it to the frame multiplexer **1306**. Frame multiplexer **1306** multiplexes the uplink serialized data streams received from each serial port **1302** into an uplink aggregate serialized data stream and passes it to serial port **1302-1**. Serial port **1302-1** receives the uplink aggregate serialized data stream and passes it to an electro-optical conversion module **1310-1**.

[0123] FIG. **13B** is a block diagram of a serial link interface unit **1002**, labeled serial link interface unit **1002B**. Serial link interface unit **1002B** includes a serial port **1302-1**, a plurality of serial ports **1304** (including serial port **1404-1**, serial port **1304-2**, and any optional serial port **1304** through serial port **1304-W**), a summer **1314**, and a simulcaster **1316**. In the forward path, the serial port **1302-1** receives a downlink aggregate serialized data stream from an electro-optical conversion module **1310-1** and passes it to the simulcaster **1016**. The simulcaster **1016** simulcasts the downlink aggregate serialized data stream to the plurality of serial ports **1304**. In the reverse path, each serial port **1304** receives an uplink serialized data stream from an electro-optical conversion module **1312** and passes it to the summer **1314**. Summer **1014** sums the uplink serialized data streams received from each serial port **1002** into an uplink aggregate serialized data stream and passes it to serial port **1302-1**. Serial port **1302-1** receives the uplink aggregate serialized data stream and passes it to an electro-optical conversion module **1310-1**.

[0124] FIG. **13C** is a block diagram of a serial link interface unit **1002**, labeled serial link interface unit **1002C**. Serial link interface unit **1002C** includes a plurality of serial ports **1302** (including serial port **1302-1** through serial port **1302-X**), a plurality of serial ports **1304** (including serial port **1304-1**,



serial port **1304-2**, and any optional serial port **1304** through serial port **1304-W**), a summer **1314**, and a simulcaster **1316**. In the forward path, the serial port **1302-1** receives a downlink aggregate serialized data stream from an electro-optical conversion module **1310-1** and passes it to the simulcaster **1316**. The simulcaster **1316** simulcasts the downlink aggregate serialized data stream to the plurality of serial ports **1304** and the serial port **1302-X**. In the reverse path, each serial port **1304** receives an uplink serialized data stream from an electro-optical conversion module **1312** and passes it to the summer **1314**. Similarly, the serial port **1302-X** receives an uplink serialized data stream from an electro-optical conversion module **1310-X** and passes it to the summer **1314**. Summer **1314** sums the uplink serialized data streams received from each serial port **1304** and the serial port **1302-X** into an uplink aggregate serialized data stream and passes it to serial port **1302-1**. Serial port **1302-1** receives the uplink aggregate serialized data stream and passes it to an electro-optical conversion module **1310-1**.

[0125] FIG. 13D is a block diagram of a serial link interface unit **1002**, labeled serial link interface unit **1002D**. Serial link interface unit **1002D** includes a plurality of serial ports **1302** (including serial port **1302-1** through serial port **1302-X**), a plurality of serial ports **1304** (including serial port **1304-1**, serial port **1304-2**, and any optional serial port **1304** through serial port **1304-W**), a frame multiplexer **1306**, a frame demultiplexer **1308**, a summer **1314**, and a simulcaster **1316**. In the forward path, the serial port **1302-1** receives a downlink aggregate serialized data stream from an electro-optical conversion module **1310-1** and passes it to the simulcaster **1316**. The simulcaster **1316** simulcasts the downlink aggregate serialized data stream to the frame de-multiplexer **1308** and the serial port **1302-X**. The frame de-multiplexer **1308** separates the downlink aggregate serialized data stream into a plurality of downlink serialized data stream and passes them to respective serial ports **1304**. In the reverse path, each serial port **1304** receives an uplink serialized data stream from an electro-optical conversion module **1312** and passes it to the frame multiplexer **1306**. Frame multiplexer **1306** multiplexes the uplink serialized data streams received from each serial port **1304** into an uplink aggregate serialized data stream and passes it to summer **1314**. The serial port **1302-X** receives an uplink serialized data stream from an electro-optical conversion module **1310-X** and passes it to the summer **1314**. Summer **1314** sums the aggregate uplink serialized data stream received from the frame multiplexer **1306** with the uplink serialized data stream received from the serial port **1302-X** into a second uplink aggregate serialized data stream and passes it to serial port **1302-1**. Serial port **1302-1** receives the second downlink aggregate serialized data stream and passes it to an electro-optical conversion module **1310-1**.

[0126] FIG. 14A-14D are block diagrams showing timeslot mapping in the serial link interfaces of FIGS. 14A-14D. Each of FIGS. 14A-14D illustrates a different embodiments of the timeslot mapping in the serial link interface of the corresponding FIGS. 13A-13D.

[0127] FIG. 14A is a block diagram showing timeslot mapping in the serial link interface **1202A**. Data streams **1404** (including data stream **1404-1**, data stream **1404-2**, and any amount of optional data streams **1404** through optional data stream **1404-W**) each include a plurality of timeslots. For example, data stream **1404-1** includes timeslots 0A, 1A, 2A, 3A, 4A, 5A, 6A, 7A, 8A, 9A, 10A, and 11A. Similarly, data stream **1404-2** includes timeslots 0B, 1B, 2B, 3B, 4B, 5B, 6B,

7B, 8B, 9B, 10B, and 11B. Other data streams include similar timeslots. In other embodiments, different amounts of timeslots are included in each data stream **1404**. Data stream **1402-1** is an aggregate data stream includes a plurality of clusters organized such that the timeslots from all the data streams **1404** are mapped into timeslot clusters so that all of the first timeslots come first, then the second timeslots, etc. Specifically, cluster 0 includes timeslot 0 from each of the data streams **1404**, such that cluster 0 includes timeslots 0A, 0B, etc. Cluster 1 includes timeslot 1 from each of the data streams **1404**, such that cluster 1 includes timeslot 1A, 1B, etc. The clusters continue accordingly. This mapping generally applies in both the forward path to downlink serialized data streams and in the reverse path to uplink serialized data streams.

[0128] FIG. 14B is a block diagram showing timeslot mapping in the serial link interface **1202B**. Data streams **1404** (including data stream **1404-1**, data stream **1404-2**, and any amount of optional data streams **1404** through optional data stream **1404-W**) and data stream **1402** are aggregate data streams and each include a plurality of clusters organized such that the timeslots from a plurality of data streams are mapped into the timeslot clusters so that all of the first timeslots come first, then the second timeslots, etc. Specifically, cluster 0 includes timeslot 0 from each of the data streams **1404**, such that cluster 0 includes timeslots 0A, 0B, etc. Cluster 1 includes timeslot 1 from each of the data streams **1404**, such that cluster 1 includes timeslot 1A, 1B, etc. The clusters continue accordingly. This mapping generally applies in both the forward path to downlink serialized data streams and in the reverse path to uplink serialized data streams.

[0129] FIG. 14C is a block diagram showing timeslot mapping in the serial link interface **1202C**. The timeslot mapping in FIG. 14C is similar to the timeslot mapping in FIG. 14B with the difference that additional data stream **1402-X** is an aggregate data stream that includes a plurality of clusters organized so that all of the first timeslots come first, then the second timeslots, etc. as with aggregate data stream **1402-1**.

[0130] FIG. 14D is a block diagram showing timeslot mapping in the serial link interface **1202D**. The timeslot mapping in FIG. 14D is similar to the timeslot mapping in FIG. 14A with the difference that additional data stream **1402-X** is an aggregate data stream that includes a plurality of clusters organized so that all of the first timeslots come first, then the second timeslots, etc. as with aggregate data stream **1402-1**.

[0131] FIG. 15 is a block diagram showing a number of serial link interface units **1502** and **1504** operating together to aggregate a plurality of serialized data streams into a single aggregate serialized data stream. In one exemplary embodiment, serial link interface unit **1502-1** receives a plurality of serialized data streams on input communication links **1506-1**, **1506-2**, **1506-3**, and **1506-4**. In one implementation, the serial link interface unit **1502-1** aggregates a plurality of lower data rate serialized data streams (such as 3.072 Gigabit per second serialized data streams) into one higher data rate aggregate serialized data stream (such as a 9.8304 Gigabit per second aggregate serialized data stream) and passes the higher data rate aggregate serialized data stream to the serial link interface unit **1504-1**. In another implementation, the serial link interface unit **1502-1** digitally sums a plurality of serialized data streams into an aggregate serialized data stream and passes the aggregate serialized data stream to the serial link interface unit **1504-1**. In exemplary embodiments,



the other serial link interface units **1502** also either aggregate lower rate signals into a higher rate aggregate signal or digitally sum signals together into aggregate signals. In exemplary embodiments, the serial link interface unit **1504-1** digitally sums the input serialized data streams into a single aggregate serialized data stream that is output on communication link **1508-1**. In other exemplary embodiments, the serial link interface unit **1504-1** aggregates a plurality of lower data rate serialized data streams into a higher data rate aggregate serialized data stream that is output on communication link **1508-1**. In other embodiments, combinations of digitally summing and data rate conversion/aggregation are facilitated in the cascaded combination of serial link interface units **1502** and serial link interface unit **1504**.

[0132] FIG. 16 is a block diagram showing a number of serial link interface units **1602** and **1604** operating together to simulcast and/or split apart an aggregate serialized data stream into a plurality of serialized data streams. In one exemplary embodiment, serial link interface unit **1602-1** receives an aggregate serialized data stream on input communication link **1606-1**. In one implementation, the aggregate serialized data stream is simulcast to the serial link interface units **1604** by serial link interface unit **1602-1**. In another implementation, the aggregate serialized data stream is at a higher rate (such as a 9.8304 Gigabit per second aggregate serialized data stream) and is split apart into a plurality of lower data rate serialized data streams (such as 3.072 Gigabit per second serialized data streams) that are communicated to the plurality of serial link interface units **1604**. In exemplary embodiments, the serial link interface units **1604** further simulcast or split apart the signals received from the serial link interface unit **1602-1**. In exemplary embodiments, some or all of the serial link interface units **1604** simulcast the corresponding serialized data streams on digital communication links **1608**. In other exemplary embodiments, some or all of the serial link interface units **1604** separate the corresponding serialized data streams into lower data rate serialized data streams on digital communication links **1608**. In other embodiments, combinations of digitally summing and data rate conversion/aggregation are facilitated in the cascaded combination of serial link interface units **1502** and serial link interface unit **1504**.

[0133] FIG. 17 is a flow diagram illustrating one exemplary embodiment of a method **1700** of aggregating and distributing serialized data streams in a distributed antenna system. Exemplary method **1700** begins at block **1702** with receiving a plurality of signals from a plurality of devices external to a distributed antenna system. In exemplary embodiments, receiving a plurality of signals from a plurality of devices external to the distributed antenna system at a plurality of network interfaces includes receiving the at least one radio frequency band from a base station. In exemplary embodiments, receiving a plurality of signals from a plurality of devices external to the distributed antenna system at a plurality of network interfaces includes receiving different radio frequency bands from at least two of the plurality of network interfaces coupled to two different base stations. In exemplary embodiments, receiving a plurality of signals from a plurality of devices external to the distributed antenna system at a plurality of network interfaces includes receiving Ethernet frames from an internet protocol network through an Ethernet interface. In exemplary embodiments, receiving a plurality of signals from a plurality of devices external to the distributed antenna system at a plurality of network interfaces

includes receiving Common Public Radio Interface (CPRI) data from a CPRI base station through a CPRI converter interface. In exemplary embodiments, receiving a plurality of signals from a plurality of devices external to the distributed antenna system at a plurality of network interfaces includes receiving a serialized baseband data stream from a base station at an embedded base station. In exemplary embodiments, receiving a plurality of signals from a plurality of devices external to the distributed antenna system at a plurality of network interfaces includes receiving a serialized baseband data stream from a base station at an embedded base station. In these exemplary embodiments, the method **1700** further includes passing the first serialized baseband data stream on as a first downlink serialized data stream of the plurality of downlink serialized data streams.

[0134] Exemplary method **1700** proceeds to block **1704** with converting the plurality of signals into a plurality of corresponding downlink serialized data streams at the plurality of network interfaces. In exemplary embodiments, at least one of the plurality of downlink serialized data streams is a serialized baseband data stream. In exemplary embodiments, the serialized baseband data stream includes quadrature samples of I/Q data. In exemplary embodiments, converting the plurality of signals into a plurality of corresponding downlink serialized data streams at the plurality of network interfaces includes converting the at least one radio frequency band to a first downlink serialized data stream of the plurality of downlink serialized data streams. In exemplary embodiments, converting the plurality of signals into a plurality of corresponding downlink serialized data streams at the plurality of network interfaces includes converting the different radio frequency bands from at least two of the plurality of network interfaces to the at least two of the corresponding downlink serialized data streams. In exemplary embodiments, converting the plurality of signals into a plurality of corresponding downlink serialized data streams at the plurality of network interfaces includes converting Ethernet frames to a first downlink serialized data stream of the plurality of downlink serialized data streams at an Ethernet interface. In exemplary implementations having Ethernet frames, the Ethernet frames are used for wireless local area network (WLAN) backhaul. In exemplary implementations having Ethernet frames, the method **1700** further includes: converting the first downlink serialized data stream extracted from the aggregate downlink serialized data stream into the Ethernet frames to an internet protocol network through a second Ethernet interface at the remote antenna unit; and communicating the Ethernet frames to an internet protocol network through a second Ethernet interface at the remote antenna unit. In some implementations, communicating the Ethernet frames to an internet protocol network through a second Ethernet interface at the remote antenna unit includes communicating the Ethernet frames to a wireless local access network (WLAN) access point. In exemplary embodiments, converting the plurality of signals into a plurality of corresponding downlink serialized data streams at the plurality of network interfaces includes converting the CPRI data into a first downlink serialized data stream of the plurality of downlink serialized data streams at the CPRI converter interface. In exemplary embodiments, converting the plurality of signals into a plurality of corresponding downlink serialized data streams at the plurality of network interfaces includes converting the serialized baseband data stream into a first downlink serialized data stream of the plurality of downlink serialized data streams at the embedded base station.

[0135] Exemplary method **1700** proceeds to block **1706** with communicating the corresponding downlink serialized data streams from the plurality of network interfaces to distributed antenna switch across a first plurality of digital communication links. In exemplary embodiments, communicating the corresponding downlink serialized data streams from the plurality of network interfaces to a distributed antenna switch across a first plurality of digital communication links includes communicating at least two of the corresponding downlink serialized data streams from at least two of the plurality of network interfaces to a serial link combiner interposed between the at least two of the plurality of network interfaces and the distributed antenna switch; aggregating the downlink serialized data streams from the at least two of the plurality of network interfaces at the serial link combiner into a second aggregate downlink serialized data stream; and communicating the second aggregate downlink serialized data stream from the serial link combiner to the distributed antenna switch. In exemplary embodiments, communicating the corresponding downlink serialized data streams from the plurality of network interfaces to a distributed antenna switch across a first plurality of digitized communication links includes communicating at least one of the downlink serialized data streams from the plurality of network interfaces to a distributed antenna switch across a fiber optic cable.

[0136] Exemplary method **1700** proceeds to block **1708** with aggregating the plurality of downlink serialized data streams into an aggregate downlink serialized data stream at the distributed antenna switch. In exemplary embodiments, aggregating the plurality of downlink data streams into the aggregate downlink serialized data stream at the distributed antenna switch includes mapping timeslots from each of the plurality of downlink serialized data streams to timeslots within the aggregate downlink serialized data stream. In exemplary embodiments, the timeslots from each of the plurality of downlink serialized data streams are interleaved within the aggregate downlink serialized data stream. In exemplary embodiments, at least one of the downlink serialized data streams is at a first data rate, the aggregate downlink serialized data stream is at a second data rate, and the second data rate is faster than the first data rate.

[0137] Exemplary method **1700** proceeds to block **1710** with communicating the aggregate downlink serialized data stream from the distributed antenna switch to a remote antenna unit. In exemplary embodiments, communicating the aggregate downlink serialized data stream from the distributed antenna switch to a remote antenna unit includes communicating the aggregate downlink serialized data stream to a serial link simulcaster and then simulcasting the aggregate downlink serialized data stream from the serial link simulcaster to the remote antenna unit and a second remote antenna unit. In these exemplary embodiments, the method further includes: extracting the plurality of downlink serialized data streams from the aggregate downlink serialized data stream at the remote antenna unit; converting at least one of the downlink serialized data streams into at least one radio frequency band at the second remote antenna unit; and transmitting signals in the at least one radio frequency band to at least one subscriber unit at the second remote antenna unit. In exemplary embodiments, communicating the aggregate downlink serialized data stream from the distributed antenna switch to a remote antenna unit includes communicating the aggregate downlink serialized data stream to a serial link separator, separating the aggregate downlink serialized data stream into

a second plurality of downlink serialized data streams at the serial link separator, and communicating each of the second plurality of downlink data streams to a different remote antenna unit of a plurality of different remote antenna units. In these exemplary embodiments, the method further comprises: extracting at least one downlink serialized data stream corresponding to a network interface from the second plurality of downlink data streams at each of the plurality of different remote antenna units; converting the at least one of the downlink serialized data streams into at least one radio frequency band at each of the plurality of different remote antenna units; and transmitting signals in the at least one subscriber unit at each of the plurality of different remote antenna units. In exemplary embodiments, communicating the aggregate downlink serialized data stream from the distributed antenna switch to a remote antenna unit includes communicating the aggregate downlink serialized data stream from the distributed antenna switch to a remote antenna unit across a fiber optic cable.

[0138] Exemplary method **1700** proceeds to block **1712** with extracting the downlink serialized data streams from the aggregate downlink serialized data stream at the remote antenna unit. Exemplary method **1700** proceeds to block **1714** with converting at least one of the downlink serialized data streams into at least one radio frequency band at the remote antenna unit. In exemplary embodiments, converting at least one of the downlink serialized data streams into at least one radio frequency band includes converting a plurality of downlink serialized data streams into a plurality of different radio frequency bands. Exemplary method **1700** proceeds to block **1716** with transmitting signals in the at least one radio frequency band to at least one subscriber unit at the remote antenna unit. In exemplary embodiments, transmitting signals in the at least one radio frequency band to at least one subscriber unit includes transmitting each of the plurality of different radio frequency bands using a different radio frequency transceiver and antenna pair. In other exemplary embodiments, transmitting signals in the at least one radio frequency band to at least one subscriber unit includes transmitting each of the plurality of different radio frequency bands using a single radio frequency transceiver and antenna pair.

[0139] In exemplary embodiments, method **1700** further includes: communicating the aggregate downlink serialized data stream from the distributed antenna switch to a second remote antenna unit; extracting the downlink serialized data streams from the aggregate downlink serialized data stream at the second remote antenna unit; converting at least one of the downlink serialized data streams into at least a second radio frequency band at the second remote antenna unit; and transmitting signals in the at least one radio frequency band to at least a second subscriber unit. In other exemplary embodiments, method **1700** further includes: aggregating a second plurality of downlink serialized data streams into a second aggregate downlink serialized data stream; communicating the second aggregate downlink serialized data stream from the distributed antenna switch to a second remote antenna unit; extracting the second plurality of downlink serialized data streams from the aggregate downlink serialized data stream at the second remote antenna unit; converting at least one of the second plurality of downlink serialized data streams into at least a second radio frequency band at the

second remote antenna unit; and transmitting signals in at least the second radio frequency band to at least a second subscriber unit.

[0140] In exemplary embodiments, method **1700** further includes: receiving second signals in a second radio frequency band from the at last one subscriber unit at the remote antenna unit; converting the second signals in the at least one radio frequency band to a first uplink serialized data stream at the remote antenna unit; aggregating the first uplink serialized data stream with other uplink serialized data streams into an aggregate uplink serialized data stream at the remote antenna unit; communicating the aggregate uplink serialized data stream from the remote antenna unit to the distributed antenna switch; extracting the first uplink serialized data stream from the aggregate uplink serialized data stream at the distributed antenna switch; communicating the first uplink serialized data stream from the distributed antenna switch to a first network interface of the plurality of network interfaces; converting the first uplink serialized data stream to third signals at the first network interface; and communicating the third signals from the first network interface to a first device external to the distributed antenna system.

[0141] In exemplary embodiments, method **1700** further includes: receiving second signals in a second radio frequency band from the at least one subscriber unit at the remote antenna unit; converting the second signals in the at least one radio frequency band to a first uplink serialized data stream at the remote antenna unit; aggregating the first uplink serialized data stream with other uplink serialized data streams into an aggregate uplink serialized data stream with other uplink serialized data streams into an aggregate uplink serialized data stream at the remote antenna unit; communicating the aggregate uplink serialized data stream from the remote antenna unit to the distributed antenna switch; communicating the first uplink serialized data stream in a second aggregate uplink serialized data stream to a serial link separator interposed between the distributed antenna switch and at least two of the plurality of network interfaces; extracting the first uplink serialized data stream from the second aggregate uplink serialized data stream at the serial link separator; communicating the first uplink serialized data stream from the serial link separator to a first network interface of the plurality of network interfaces; converting the first uplink serialized data stream to third signals at the first network interface; and communicating the third signals from the first network interface to a first device external to the distributed antenna system.

[0142] In exemplary embodiments, method **1700** further includes: receiving second signals in a second radio frequency band from the at least one subscriber unit at the remote antenna unit; converting the second signals in the at least one radio frequency band to a first uplink serialized data stream at the remote antenna unit; communicating the first uplink serialized data stream to a serial link combiner interposed between the remote antenna unit and the distributed antenna switch; aggregating the first uplink serialized data stream with other uplink serialized data streams into an aggregate uplink serialized data stream with other uplink serialized data streams into an aggregate uplink serialized data stream at the serial link combiner; communicating the aggregate uplink serialized data stream from the serial link combiner to the distributed antenna switch; extracting the first uplink serialized data stream from the aggregate uplink serialized data stream at the distributed antenna switch; commu-

nicating the first uplink serialized data stream from the distributed antenna switch to a first network interface of the plurality of network interfaces; converting the first uplink serialized data stream to third signals at the first network interface; and communicating the third signals from the first network interface to first device external to the distributed antenna system.

[0143] FIGS. **18A-18C** are flow diagrams illustrating exemplary embodiments of methods **1800** of aggregating serialized data streams in a distributed antenna switch. Each of FIGS. **18A-18C** illustrates a different embodiment of methods **1800**, labeled method **1800A-1800C** respectively.

[0144] FIG. **18A** is a flow diagram illustrating exemplary method **1800A** of aggregating serialized data streams in a distributed antenna switch. Exemplary method **1800A** begins at block **1802** with receiving a plurality of downlink serialized data streams from a first plurality of digital communication links. Exemplary method **1800A** proceeds to block **1804** with aggregating the plurality of downlink serialized data streams from the different network interfaces into an aggregate downlink serialized data stream. Exemplary method **1800A** proceeds to block **1806** with communicating the aggregate downlink serialized data stream to a remote antenna unit over a second digital communication link.

[0145] FIG. **18B** is a flow diagram illustrating exemplary method **1800B** of aggregating serialized data streams in a distributed antenna switch. Exemplary method **1800B** includes blocks **1802**, **1804**, and **1806** of method **1800A** described above. After block **1806**, exemplary method **1800B** proceeds to block **1808** with communicating the aggregate downlink serialized data stream to a second remote antenna unit over a third digital communication link.

[0146] FIG. **18C** is a flow diagram illustrating exemplary method **1800C** of aggregating serialized data streams in a distributed antenna switch. Exemplary method **1800C** includes blocks **1802**, **1804**, and **1806** of method **1800A** described above. After block **1806**, exemplary method **1800C** proceeds to block **1810** with receiving an aggregate uplink serialized data stream from the remote antenna unit over the second digital communication link. Exemplary method **1800C** proceeds to block **1812** with splitting the aggregate uplink serialized data stream into a plurality of uplink serialized data streams **1812**. Exemplary method **1800C** proceeds to block **1814** with communicating the plurality of uplink serialized data streams through the first plurality of digital communication links.

[0147] FIG. **19** is a flow diagram illustrating one exemplary embodiment of a method **1900** of aggregating a plurality of serialized data streams into an aggregate serialized data stream. Exemplary method **1900** begins at block **1902** with receiving plurality of different serialized data streams each having a data rate and a set of timeslots. In exemplary embodiments, the plurality of different serialized data streams include at least a first serialized data stream having a first data rate and a first set of timeslots and a second serialized data stream having a second data rate and a second set of timeslots. In exemplary embodiments, the plurality of different serialized data streams further include a third serialized data stream having a third data rate and a third set of timeslots, and a fourth serialized data stream having a fourth data rate and a fourth set of timeslots. In exemplary embodiments, receiving the plurality of different serialized data streams

includes receiving downlink serialized data streams from the plurality of different network interfaces across different first digital communication links.

[0148] Exemplary method **1900** proceeds to block **1904** with communicating an aggregate serialized data stream having an aggregate data rate and a plurality of aggregate timeslot sets, each set of the plurality of aggregate timeslot sets coming sequentially in time, wherein a second aggregate timeslot set of the plurality of aggregate timeslot sets comes after a first aggregate timeslot set of the plurality of aggregate timeslot sets. In exemplary embodiments, communicating the aggregate serialized data stream includes communicating the aggregate serialized data stream to a distributed antenna switch over a second digital communication link.

[0149] Exemplary method **1900** proceeds to block **1906** with interleaving data from the plurality of different serialized data streams by mapping data from a first timeslot from the set of timeslots for each different serialized data stream to the first aggregate timeslot set of the plurality of aggregate timeslot sets in the aggregate serialized data stream and mapping data from a second timeslot from the set of timeslots for each different serialized data stream to the second aggregate timeslot set of the plurality of aggregate timeslot sets in the aggregate serialized data stream. In exemplary embodiments, mapping data from a first timeslot from the set of timeslots for each different serialized data stream to the first aggregate timeslot set of the plurality of aggregate timeslot sets in the aggregate serialized data stream includes mapping data from a first timeslot from the set of timeslots to a first timeslot in the first aggregate timeslot set of the plurality of aggregate timeslot sets and data from a first timeslot from the second set of timeslots to a second timeslot in the first aggregate timeslot set of the plurality of aggregate timeslot sets. In exemplary embodiments, mapping data from a first timeslot from the set of timeslots for each different serialized data stream to the first aggregate timeslot set of the plurality of aggregate timeslot sets in the aggregate serialized data stream further includes mapping data from data from a first timeslot from the third set of timeslots to a third timeslot in the first aggregate timeslot set of the plurality of aggregate timeslot sets, and data from a first timeslot from the fourth set of timeslots to a fourth timeslot in the first aggregate timeslot set of the plurality of aggregate timeslot sets.

[0150] In exemplary embodiment, the method **1900** further includes communicating the aggregate serialized data stream at both a first aggregate serialized data stream interface and a second serialized data stream interface. In exemplary embodiments, at least one of the different serialized data streams includes at least one of a serialized baseband data stream, a serialized intermediate frequency data stream, and a serialized radio frequency data stream corresponding to a radio frequency band communicated by a base station. In exemplary embodiments, the aggregate data rate is faster than the data rate.

[0151] In exemplary embodiments, mapping data from a second timeslot from the set of timeslots for each different serialized data stream to the second aggregate timeslot set of the plurality of aggregate timeslot sets in the aggregate serialized data stream includes mapping data from a second timeslot from the first set of timeslots to a first timeslot in the second aggregate timeslot set of the plurality of aggregate timeslot sets and data from a second timeslot from the second set of timeslots to a second timeslot in the second aggregate timeslot set of the plurality of aggregate timeslot sets. In

exemplary embodiments, mapping data from a second timeslot from the set of timeslots for each different serialized data stream to the second aggregate timeslot set of the plurality of aggregate timeslot sets in the aggregate serialized data stream includes mapping data from a second timeslot from the third set of timeslots to a third timeslot in the second aggregate timeslot set of the plurality of aggregate timeslot sets, and data from a second timeslot from the fourth set of timeslots to a fourth timeslot in the second aggregate timeslot set of the plurality of aggregate timeslot sets.

[0152] In exemplary embodiments, a third aggregate timeslot set of the plurality of aggregate timeslot sets comes after the second aggregate timeslot set of the plurality of aggregate timeslot sets. In these embodiments, the method **1900** further includes further interleaving data from the plurality of different serialized data streams by mapping data from a third timeslot from the set of timeslots for each different serialized data stream to the third aggregate timeslot set of the plurality of aggregate timeslot sets in the aggregate serialized data stream. In exemplary embodiments, mapping data from a third timeslot from the set of timeslots for each different serialized data stream to the third aggregate timeslot set of the plurality of aggregate timeslot sets in the aggregate serialized data stream includes mapping data from a third timeslot from the first set of timeslots to a first timeslot in the third aggregate timeslot set of the plurality of aggregate timeslot sets and data from a third timeslot from the second set of timeslots to a second timeslot in the third aggregate timeslot set of the plurality of aggregate timeslot sets. In exemplary embodiments, mapping data from a third timeslot from the set of timeslots for each different serialized data stream to the third aggregate timeslot set of the plurality of aggregate timeslot sets in the aggregate serialized data stream further includes mapping data from a third timeslot from the third set of timeslots to a third timeslot in the third aggregate timeslot set of the plurality of aggregate timeslot sets and data from a third timeslot from the fourth set of timeslots to a fourth timeslot in the third aggregate timeslot set of the plurality of aggregate timeslot sets.

[0153] In exemplary embodiments, the method **1900** further includes: receiving a second aggregate serialized data stream having a second aggregate data rate and a second plurality of aggregate timeslot sets, each set of the second plurality of aggregate timeslot sets coming sequentially in time, wherein a first aggregate timeslot set of the second plurality of aggregate timeslot sets comes before a second aggregate timeslot set of the second plurality of aggregate timeslot sets; communicating a different second serialized data stream having a second data rate and a second set of timeslots; and de-interleaving data from the second aggregate serialized data stream by mapping data from the first aggregate timeslot set of the second plurality of aggregate timeslot sets to a first timeslot from the second set of timeslots for each different serialized data stream and mapping data from the second aggregate timeslot set of the second plurality of aggregate timeslot sets to a second timeslot from the second set of timeslots for each different serialized data stream.

[0154] In exemplary embodiments, the method **1900** further includes: receiving a second aggregate serialized data stream having a second aggregate data rate and a second plurality of aggregate timeslot sets, each set of the second plurality of aggregate timeslot sets coming sequentially in time, wherein a second aggregate timeslot set of the second plurality of aggregate timeslot sets comes after a first aggregate

gate timeslot set of the second plurality of aggregate timeslot sets; communicating a different second serialized data stream having a second data rate and a second set of timeslots; and de-interleaving data from the second aggregate serialized data stream by mapping data from the first aggregate timeslot set of the second plurality of aggregate timeslot sets to a first timeslot from the second set of timeslots for each different serialized data stream and mapping data from the second aggregate timeslot set of the second plurality of aggregate timeslot sets to a second timeslot from the second set of timeslots for each different serialized data stream.

[0155] In exemplary embodiments, the method **1900** further includes: receiving a second aggregate serialized data stream having a second aggregate data rate and a second plurality of aggregate timeslot sets, each set of the second plurality of aggregate timeslot sets coming sequentially in time, wherein a second aggregate timeslot set of the second plurality of aggregate timeslot sets comes after a first aggregate timeslot set of the second plurality of aggregate timeslot sets; and digitally summing the second aggregate serialized data stream into the aggregate serialized data stream before communicating the aggregate serialized data stream. In exemplary embodiments, digitally summing the second aggregate serialized data stream into the aggregate serialized data stream includes summing data in each timeslot of the second aggregate serialized data stream into data in a corresponding timeslot of the aggregate serialized data stream, such that data in each timeslot in the first aggregate timeslot set of the second aggregate serialized data stream is summed into data in a corresponding timeslot in the first aggregate timeslot set of the aggregate serialized data stream and data in each timeslot in the second aggregate timeslot set of the second aggregate serialized data stream is summed into data in a corresponding timeslot in the second aggregate timeslot set of the aggregate serialized data stream.

[0156] FIG. 20 is a flow diagram illustrating one exemplary embodiment of a method **2000** of splitting apart an aggregate serialized data stream into a plurality of serialized data streams. Exemplary method **2000** begins at block **2002** with receiving an aggregate serialized data stream having an aggregate data rate and a plurality of aggregate timeslot sets, each set of the plurality of aggregate timeslot sets coming sequentially in time, wherein a second aggregate timeslot set of the plurality of aggregate timeslot sets comes after a first aggregate timeslot set of the plurality of aggregate timeslot sets.

[0157] Exemplary method **2000** proceeds to block **2004** with communicating a plurality of different serialized data streams each having a data rate and a set of timeslots.

[0158] Exemplary method **2000** proceeds to block **2006** with de-interleaving data from the aggregate serialized data stream by mapping data from the first aggregate timeslot set of the plurality of aggregate timeslot sets to a first timeslot from the set of timeslots for each different serialized data stream and being configured to map data from the second aggregate timeslot set of the plurality of aggregate timeslot sets to a second timeslot from the set of timeslots for each different serialized data stream.

[0159] In exemplary embodiments, the plurality of different serialized data streams include at least a first serialized data stream having a first data rate and a first set of timeslots and a second serialized data stream having a second data rate and a second set of timeslots. In exemplary embodiments,

mapping data from the first aggregate timeslot set of the plurality of aggregate timeslot sets to a first timeslot from the set of timeslots for each different serialized data stream includes mapping data from a first timeslot in the first aggregate timeslot set of the plurality of aggregate timeslot sets to a first timeslot from the first set of timeslots and data from a second timeslot in the first aggregate timeslot set of the plurality of aggregate timeslot sets to a first timeslot from the second set of timeslots. In exemplary embodiments, mapping data from the second aggregate timeslot set of the plurality of aggregate timeslot sets to a second timeslot from the set of timeslots for each different serialized data stream includes mapping data from a first timeslot in the second aggregate timeslot set of the plurality of aggregate timeslot sets to a second timeslot from the first set of timeslots and data from a second timeslot in the second aggregate timeslot set of the plurality of aggregate timeslot sets to a second timeslot from the second set of timeslots.

[0160] In exemplary embodiments, the plurality of different serialized data streams include at least a first serialized data stream having a first data rate and a first set of timeslots, a second serialized data stream having a second data rate and a second set of timeslots, a third serialized data stream having a third data rate and a third set of timeslots, and a fourth serialized data stream having a fourth data rate and a fourth set of timeslots. In exemplary embodiments, mapping data from the first aggregate timeslot set of the plurality of aggregate timeslot sets to a first timeslot from the set of timeslots for each different serialized data stream includes mapping data from a first timeslot in the first aggregate timeslot set of the plurality of aggregate timeslot sets to a first timeslot from the first set of timeslots, data from a second timeslot in the first aggregate timeslot set of the plurality of aggregate timeslot sets to a first timeslot from the second set of timeslots, data from a third timeslot in the first aggregate timeslot set of the plurality of aggregate timeslot sets to a first timeslot from the third set of timeslots, and data from a fourth timeslot in the first aggregate timeslot set of the plurality of aggregate timeslot sets to a first timeslot from the fourth set of timeslots. In exemplary embodiments, mapping data from the second aggregate timeslot set of the plurality of aggregate timeslot sets to a second timeslot from the set of timeslots for each different serialized data stream includes mapping data from a first timeslot in the second aggregate timeslot set of the plurality of aggregate timeslot sets to a second timeslot from the first set of timeslots, data from a second timeslot in the second aggregate timeslot set of the plurality of aggregate timeslot sets to a second timeslot from the second set of timeslots, data from a third timeslot in the second aggregate timeslot set of the plurality of aggregate timeslot sets to a second timeslot from the third set of timeslots, and data from a fourth timeslot in the second aggregate timeslot set of the plurality of aggregate timeslot sets to a second timeslot from the fourth set of timeslots.

[0161] In exemplary embodiments, a third aggregate timeslot set of the plurality of aggregate timeslot sets comes after the second aggregate timeslot set of the plurality of aggregate timeslot sets. In these embodiments, the method **2000** further includes further de-interleaving data from the aggregate serialized data stream received at the aggregate serialized data stream interface by mapping data from the third aggregate timeslot set of the plurality of aggregate timeslot sets to a third timeslot from the set of timeslots for each different serialized data stream and being configured to

map data from the second aggregate timeslot set of the plurality of aggregate timeslot sets to a second timeslot from the set of timeslots for each different serialized data stream.

**[0162]** In exemplary embodiments having a third aggregate timeslot, the different serialized data streams include at least a first serialized data stream having a first data rate and a first set of timeslots and a second serialized data stream having a second data rate and a second set of timeslots. In exemplary embodiments, mapping data from the first aggregate timeslot set of the plurality of aggregate timeslot sets to a first timeslot from the set of timeslots for each different serialized data stream includes mapping data from a first timeslot in the first aggregate timeslot set of the plurality of aggregate timeslot sets to a first timeslot from the first set of timeslots and data from a second timeslot in the first aggregate timeslot set of the plurality of aggregate timeslot sets to a first timeslot from the second set of timeslots; mapping data from the second aggregate timeslot set of the plurality of aggregate timeslot sets to a second timeslot from the set of timeslots for each different serialized data stream includes mapping data from a first timeslot in the second aggregate timeslot set of the plurality of aggregate timeslot sets to a second timeslot from the first set of timeslots and data from a second timeslot in the second aggregate timeslot set of the plurality of aggregate timeslot sets to a second timeslot from the second set of timeslots; and mapping data from the third aggregate timeslot set of the plurality of aggregate timeslot sets to a third timeslot from the set of timeslots for each different serialized data stream includes mapping data from a first timeslot in the third aggregate timeslot set of the plurality of aggregate timeslot sets to a third timeslot from the first set of timeslots and data from a second timeslot in the third aggregate timeslot set of the plurality of aggregate timeslot sets to a third timeslot from the second set of timeslots.

**[0163]** In exemplary embodiments having a third aggregate timeslot, the different serialized data streams include at least a first serialized data stream having a first data rate and a first set of timeslots, a second serialized data stream having a second data rate and a second set of timeslots, a third serialized data stream having a third data rate and a third set of timeslots, and a fourth serialized data stream having a fourth data rate and a fourth set of timeslots. In exemplary embodiments, mapping data from the first aggregate timeslot set of the plurality of aggregate timeslot sets to a first timeslot from the set of timeslots for each different serialized data stream includes mapping data from a first timeslot in the first aggregate timeslot set of the plurality of aggregate timeslot sets to a first timeslot from the first set of timeslots, data from a second timeslot in the first aggregate timeslot set of the plurality of aggregate timeslot sets to a first timeslot from the second set of timeslots, data from a third timeslot in the first aggregate timeslot set of the plurality of aggregate timeslot sets to a first timeslot from the third set of timeslots, and data from a fourth timeslot in the first aggregate timeslot set of the plurality of aggregate timeslot sets to a first timeslot from the fourth set of timeslots; mapping data from the second aggregate timeslot set of the plurality of aggregate timeslot sets to a second timeslot from the set of timeslots for each different serialized data stream includes mapping data from a first timeslot in the second aggregate timeslot set of the plurality of aggregate timeslot sets to a second timeslot from the first set of timeslots, data from a second timeslot in the second aggregate timeslot set of the plurality of aggregate timeslot sets to a second timeslot from the second set of timeslots, data from

a third timeslot in the second aggregate timeslot set of the plurality of aggregate timeslot sets to a second timeslot from the third set of timeslots, and data from a fourth timeslot in the second aggregate timeslot set of the plurality of aggregate timeslot sets to a second timeslot from the fourth set of timeslots; and mapping data from the third aggregate timeslot set of the plurality of aggregate timeslot sets to a third timeslot from the set of timeslots for each different serialized data stream includes mapping data from a first timeslot in the third aggregate timeslot set of the plurality of aggregate timeslot sets to a third timeslot from the first set of timeslots, data from a second timeslot in the third aggregate timeslot set of the plurality of aggregate timeslot sets to a third timeslot from the second set of timeslots, data from a third timeslot in the third aggregate timeslot set of the plurality of aggregate timeslot sets to a third timeslot from the third set of timeslots, and data from a fourth timeslot in the third aggregate timeslot set of the plurality of aggregate timeslot sets to a third timeslot from the fourth set of timeslots.

**[0164]** In exemplary embodiments, the at least one of the different serialized data streams includes at least one of a serialized baseband data stream, a serialized intermediate frequency data stream, and a serialized radio frequency data stream corresponding to a radio frequency band communication by a base station. In exemplary embodiments, the aggregate data rate is faster than the data rate.

**[0165]** FIG. 21 is a block diagram of an embodiment of an additional exemplary distributed antenna system 2100 having a distributed antenna switch 2102 and a variety of different network interfaces including baseband network interfaces 2104 communicatively coupled to baseband ports on base stations 2106, CPRI network interfaces 2108 communicatively coupled to CPRI ports on base station 2106, Ethernet network interfaces 2112 communicatively coupled to internet protocol (IP) networks 2114, and embedded distributed antenna systems 2116. The distributed antenna system 2100 also has serial link interface units 2118 and remote antenna units 2120. The various components operate as described above. Only the embedded distributed antenna system (eDAS) has not been described earlier. An eDAS includes some base station functionality in the network interface itself, such that the eDAS can connect with a wireless access network as a base station would, without requiring all the radio frequency hardware necessary for a full base station and instead relying on the distributed antenna system for signal radiation to wireless subscribers. Other topologies can also be used with various modifications to the network topology.

**[0166]** Embodiments of the processors described herein include or function with software programs, firmware or other computer readable instructions for carrying out various methods, process tasks, calculations, and control functions, used in the components of the systems described above.

**[0167]** These instructions are typically stored on any appropriate computer readable medium used for storage of computer readable instructions or data structures. The computer readable medium can be implemented as any available media that can be accessed by a general purpose or special purpose computer or processor, or any programmable logic device. Suitable processor-readable media may include storage or memory media such as magnetic or optical media. For example, storage or memory media may include conventional hard disks, Compact Disk-Read Only Memory (CD-ROM), volatile or non-volatile media such as Random Access Memory (RAM) (including, but not limited to, Synchronous

Dynamic Random Access Memory (SDRAM), Double Data Rate (DDR) RAM, RAMBUS Dynamic RAM (RDRAM), Static RAM (SRAM), etc.), Read Only Memory (ROM), Electrically Erasable Programmable ROM (EEPROM), and flash memory, etc. Suitable processor-readable media may also include transmission media such as electrical, electromagnetic, or digital signals, conveyed via a communication medium such as a network and/or a wireless link.

**[0168]** Although specific embodiments have been illustrated and described herein, it will be appreciated by those of ordinary skill in the art that any arrangement, which is calculated to achieve the same purpose, may be substituted for the specific embodiments shown. Therefore, it is manifestly intended that this invention be limited only by the claims and the equivalents thereof.

#### EXAMPLE EMBODIMENTS

**[0169]** Example 1 includes a serial link interface unit comprising: a plurality of serialized data stream interfaces, each of the plurality of serialized data stream interfaces configured to receive a different serialized data stream having a data rate and a set of timeslots; an aggregate serialized data stream interface configured to communicate an aggregate serialized data stream having an aggregate data rate and a plurality of aggregate timeslot sets, each set of the plurality of aggregate timeslot sets coming sequentially in time, wherein a second aggregate timeslot set of the plurality of aggregate timeslot sets comes after a first aggregate timeslot set of the plurality of aggregate timeslot sets; and wherein the serial link interface unit is configured to interleave data from the different serialized data streams received at the plurality of first interfaces by being configured to map data from a first timeslot from the set of timeslots for each different serialized data stream to the first aggregate timeslot set of the plurality of aggregate timeslot sets in the aggregate serialized data stream and being configured to map data from a second timeslot from the set of timeslots for each different serialized data stream to the second aggregate timeslot set of the plurality of aggregate timeslot sets in the aggregate serialized data stream.

**[0170]** Example 2 includes the serial link interface unit of Example 1, wherein the different serialized data streams include at least a first serialized data stream having a first data rate and a first set of timeslots and a second serialized data stream having a second data rate and a second set of timeslots; wherein being configured to map data from a first timeslot from the set of timeslots for each different serialized data stream to the first aggregate timeslot set of the plurality of aggregate timeslot sets in the aggregate serialized data stream includes being configured to map data from a first timeslot from the first set of timeslots to a first timeslot in the first aggregate timeslot set of the plurality of aggregate timeslot sets and data from a first timeslot from the second set of timeslots to a second timeslot in the first aggregate timeslot set of the plurality of aggregate timeslot sets; and wherein being configured to map data from a second timeslot from the set of timeslots for each different serialized data stream to the second aggregate timeslot set of the plurality of aggregate timeslot sets in the aggregate serialized data stream includes being configured to map data from a second timeslot from the first set of timeslots to a first timeslot in the second aggregate timeslot set of the plurality of aggregate timeslot sets and data from a second timeslot from the second set of timeslots to a second timeslot in the second aggregate timeslot set of the plurality of aggregate timeslot sets.

**[0171]** Example 3 includes the serial link interface unit of any of Examples 1-2, wherein the different serialized data streams include a first serialized data stream having a first data rate and a first set of timeslots, a second serialized data stream having a second data rate and a second set of timeslots, a third serialized data stream having a third data rate and a third set of timeslots, and a fourth serialized data stream having a fourth data rate and a fourth set of timeslots; wherein being configured to map data from a first timeslot from the set of timeslots for each different serialized data stream to the first aggregate timeslot set of the plurality of aggregate timeslot sets in the aggregate serialized data stream includes being configured to map data from a first timeslot from the first set of timeslots to a first timeslot in the first aggregate timeslot set of the plurality of aggregate timeslot sets, data from a first timeslot from the second set of timeslots to a second timeslot in the first aggregate timeslot set of the plurality of aggregate timeslot sets, data from a first timeslot from the third set of timeslots to a third timeslot in the first aggregate timeslot set of the plurality of aggregate timeslot sets, and data from a first timeslot from the fourth set of timeslots to a fourth timeslot in the first aggregate timeslot set of the plurality of aggregate timeslot sets; and wherein being configured to map data from a second timeslot from the set of timeslots for each different serialized data stream to the second aggregate timeslot set of the plurality of aggregate timeslot sets in the aggregate serialized data stream includes being configured to map data from a second timeslot from the first set of timeslots to a first timeslot in the second aggregate timeslot set of the plurality of aggregate timeslot sets, data from a second timeslot from the second set of timeslots to a second timeslot in the second aggregate timeslot set of the plurality of aggregate timeslot sets, data from a second timeslot from the third set of timeslots to a third timeslot in the second aggregate timeslot set of the plurality of aggregate timeslot sets, and data from a second timeslot from the fourth set of timeslots to a fourth timeslot in the second aggregate timeslot set of the plurality of aggregate timeslot sets.

**[0172]** Example 4 includes the serial link interface unit of any of Examples 1-3, wherein a third aggregate timeslot set of the plurality of aggregate timeslot sets comes after the second aggregate timeslot set of the plurality of aggregate timeslot sets; and wherein the serial link interface unit is further configured to interleave data from the different serialized data streams received at the plurality of first interfaces by being configured to map data from a third timeslot from the set of timeslots for each different serialized data stream to the third aggregate timeslot set of the plurality of aggregate timeslot sets in the aggregate serialized data stream.

**[0173]** Example 5 includes the serial link interface unit of Example 4, wherein the different serialized data streams include at least a first serialized data stream having a first data rate and a first set of timeslots and a second serialized data stream having a second data rate and a second set of timeslots; wherein being configured to map data from a first timeslot from the set of timeslots for each different serialized data stream to the first aggregate timeslot set of the plurality of aggregate timeslot sets in the aggregate serialized data stream includes being configured to map data from a first timeslot from the first set of timeslots to a first timeslot in the first aggregate timeslot set of the plurality of aggregate timeslot sets and data from a first timeslot from the second set of timeslots to a second timeslot in the first aggregate timeslot set of the plurality of aggregate timeslot sets; wherein being



configured to map data from a second timeslot from the set of timeslots for each different serialized data stream to the second aggregate timeslot set of the plurality of aggregate timeslot sets in the aggregate serialized data stream includes being configured to map data from a second timeslot from the first set of timeslots to a first timeslot in the second aggregate timeslot set of the plurality of aggregate timeslot sets and data from a second timeslot from the second set of timeslots to a second timeslot in the second aggregate timeslot set of the plurality of aggregate timeslot sets; and wherein being configured to map data from a third timeslot from the set of timeslots for each different serialized data stream to the third aggregate timeslot set of the plurality of aggregate timeslot sets in the aggregate serialized data stream includes being configured to map data from a third timeslot from the first set of timeslots to a first timeslot in the third aggregate timeslot set of the plurality of aggregate timeslot sets and data from a third timeslot from the second set of timeslots to a second timeslot in the third aggregate timeslot set of the plurality of aggregate timeslot sets.

**[0174]** Example 6 includes the serial link interface unit of any of Examples 4-5, wherein the different serialized data streams include a first serialized data stream having a first data rate and a first set of timeslots, a second serialized data stream having a second data rate and a second set of timeslots, a third serialized data stream having a third data rate and a third set of timeslots, and a fourth serialized data stream having a fourth data rate and a fourth set of timeslots; wherein being configured to map data from a first timeslot from the set of timeslots for each different serialized data stream to the first aggregate timeslot set of the plurality of aggregate timeslot sets in the aggregate serialized data stream includes being configured to map data from a first timeslot from the first set of timeslots to a first timeslot in the first aggregate timeslot set of the plurality of aggregate timeslot sets, data from a first timeslot from the second set of timeslots to a second timeslot in the first aggregate timeslot set of the plurality of aggregate timeslot sets, data from a first timeslot from the third set of timeslots to a third timeslot in the first aggregate timeslot set of the plurality of aggregate timeslot sets, and data from a first timeslot from the fourth set of timeslots to a fourth timeslot in the first aggregate timeslot set of the plurality of aggregate timeslot sets; wherein being configured to map data from a second timeslot from the set of timeslots for each different serialized data stream to the second aggregate timeslot set of the plurality of aggregate timeslot sets in the aggregate serialized data stream includes being configured to map data from a second timeslot from the first set of timeslots to a first timeslot in the second aggregate timeslot set of the plurality of aggregate timeslot sets, data from a second timeslot from the second set of timeslots to a second timeslot in the second aggregate timeslot set of the plurality of aggregate timeslot sets, data from a second timeslot from the third set of timeslots to a third timeslot in the second aggregate timeslot set of the plurality of aggregate timeslot sets, and data from a second timeslot from the fourth set of timeslots to a fourth timeslot in the second aggregate timeslot set of the plurality of aggregate timeslot sets; and wherein being configured to map data from a third timeslot from the set of timeslots for each different serialized data stream to the third aggregate timeslot set of the plurality of aggregate timeslot sets in the aggregate serialized data stream includes being configured to map data from a third timeslot from the first set of timeslots to a first timeslot in the third

aggregate timeslot set of the plurality of aggregate timeslot sets, data from a third timeslot from the second set of timeslots to a second timeslot in the third aggregate timeslot set of the plurality of aggregate timeslot sets, data from a third timeslot from the third set of timeslots to a third timeslot in the third aggregate timeslot set of the plurality of aggregate timeslot sets, and data from a third timeslot from the fourth set of timeslots to a fourth timeslot in the third aggregate timeslot set of the plurality of aggregate timeslot sets.

**[0175]** Example 7 includes the serial link interface unit of any of Examples 1-6, further comprising: wherein the serial link interface unit is used in a distributed antenna system; wherein the plurality of serialized data stream interfaces are configured to receive downlink serialized data streams from a different network interface across a different first digital communication link; and wherein the aggregate serialized data stream interface is configured to communicate the aggregate serialized data stream to a distributed antenna switch over a second digital communication link.

**[0176]** Example 8 includes the serial link interface unit of any of Examples 1-7, further comprising: wherein the aggregate serialized data stream interface is further configured to receive a second aggregate serialized data stream having a second aggregate data rate and a second plurality of aggregate timeslot sets, each set of the second plurality of aggregate timeslot sets coming sequentially in time, wherein a first aggregate timeslot set of the second plurality of aggregate timeslot sets comes before a second aggregate timeslot set of the second plurality of aggregate timeslot sets; wherein the plurality of serialized data stream interfaces are each further configured to communicate a different second serialized data stream having a second data rate and a second set of timeslots; and wherein the serial link interface unit is further configured to de-interleave data from the second aggregate serialized data stream by being further configured to map data from the first aggregate timeslot set of the second plurality of aggregate timeslot sets to a first timeslot from the second set of timeslots for each different serialized data stream and being configured to map data from the second aggregate timeslot set of the second plurality of aggregate timeslot sets to a second timeslot from the second set of timeslots for each different serialized data stream.

**[0177]** Example 9 includes the serial link interface unit of any of Examples 1-8, further comprising: a second aggregate serialized data stream interface configured to communicate the aggregate serialized data stream.

**[0178]** Example 10 includes the serial link interface unit of any of Examples 1-9, further comprising: a second aggregate serialized data stream interface configured to receive a second aggregate serialized data stream having a second aggregate data rate and a second plurality of aggregate timeslot sets, each set of the second plurality of aggregate timeslot sets coming sequentially in time, wherein a first aggregate timeslot set of the second plurality of aggregate timeslot sets comes before a second aggregate timeslot set of the second plurality of aggregate timeslot sets; wherein the plurality of serialized data stream interfaces are each further configured to communicate a different second serialized data stream having a second data rate and a second set of timeslots; and wherein the serial link interface unit is further configured to de-interleave data from the second aggregate serialized data stream by being further configured to map data from the first aggregate timeslot set of the second plurality of aggregate timeslot sets to a first timeslot from the second set of timeslots



for each different serialized data stream and being configured to map data from the second aggregate timeslot set of the second plurality of aggregate timeslot sets to a second timeslot from the second set of timeslots for each different serialized data stream.

**[0179]** Example 11 includes the serial link interface unit of any of Examples 1-10, further comprising: a second aggregate serialized data stream interface configured to receive a second aggregate serialized data stream having a second aggregate data rate and a second plurality of aggregate timeslot sets, each set of the second plurality of aggregate timeslot sets coming sequentially in time, wherein a second aggregate timeslot set of the second plurality of aggregate timeslot sets comes after a first aggregate timeslot set of the second plurality of aggregate timeslot sets; and wherein the serial link interface unit is further configured to digitally sum the second aggregate serialized data stream into the aggregate serialized data stream before communicating the aggregate serialized data stream.

**[0180]** Example 12 includes the serial link interface unit of Example 11, further comprising: wherein the serial link interface unit is configured to digitally sum the second aggregate serialized data stream into the aggregate serialized data stream by being configured to sum data in each timeslot of the second aggregate serialized data stream into data in a corresponding timeslot of the aggregate serialized data stream, such that data in each timeslot in the first aggregate timeslot set of the second aggregate serialized data stream is summed into data in a corresponding timeslot in the first aggregate timeslot set of the aggregate serialized data stream and data in each timeslot in the second aggregate timeslot set of the second aggregate serialized data stream is summed into data in a corresponding timeslot in the second aggregate timeslot set of the aggregate serialized data stream.

**[0181]** Example 13 includes the serial link interface unit of any of Examples 1-12, wherein at least one of the different serialized data streams includes at least one of a serialized baseband data stream, a serialized intermediate frequency data stream, and a serialized radio frequency data stream corresponding to a radio frequency band communicated by a base station.

**[0182]** Example 14 includes the serial link interface unit of any of Examples 1-13, wherein the aggregate data rate is faster than the data rate.

**[0183]** Example 15 includes a method of aggregating a plurality of serialized data streams into an aggregate serialized data stream, the method comprising: receiving a plurality of different serialized data streams each having a data rate and a set of timeslots; communicating an aggregate serialized data stream having an aggregate data rate and a plurality of aggregate timeslot sets, each set of the plurality of aggregate timeslot sets coming sequentially in time, wherein a second aggregate timeslot set of the plurality of aggregate timeslot sets comes after a first aggregate timeslot set of the plurality of aggregate timeslot sets; and interleaving data from the plurality of different serialized data streams by mapping data from a first timeslot from the set of timeslots for each different serialized data stream to the first aggregate timeslot set of the plurality of aggregate timeslot sets in the aggregate serialized data stream and mapping data from a second timeslot from the set of timeslots for each different serialized data stream to the second aggregate timeslot set of the plurality of aggregate timeslot sets in the aggregate serialized data stream.

**[0184]** Example 16 includes the method of Example 15, wherein the plurality of different serialized data streams include at least a first serialized data stream having a first data rate and a first set of timeslots and a second serialized data stream having a second data rate and a second set of timeslots; wherein mapping data from a first timeslot from the set of timeslots for each different serialized data stream to the first aggregate timeslot set of the plurality of aggregate timeslot sets in the aggregate serialized data stream includes mapping data from a first timeslot from the first set of timeslots to a first timeslot in the first aggregate timeslot set of the plurality of aggregate timeslot sets and data from a first timeslot from the second set of timeslots to a second timeslot in the first aggregate timeslot set of the plurality of aggregate timeslot sets; and wherein mapping data from a second timeslot from the set of timeslots for each different serialized data stream to the second aggregate timeslot set of the plurality of aggregate timeslot sets in the aggregate serialized data stream includes mapping data from a second timeslot from the first set of timeslots to a first timeslot in the second aggregate timeslot set of the plurality of aggregate timeslot sets and data from a second timeslot from the second set of timeslots to a second timeslot in the second aggregate timeslot set of the plurality of aggregate timeslot sets.

**[0185]** Example 17 includes the method of any of Examples 15-16, wherein the plurality of different serialized data streams include a first serialized data stream having a first data rate and a first set of timeslots, a second serialized data stream having a second data rate and a second set of timeslots, a third serialized data stream having a third data rate and a third set of timeslots, and a fourth serialized data stream having a fourth data rate and a fourth set of timeslots; wherein mapping data from a first timeslot from the set of timeslots for each different serialized data stream to the first aggregate timeslot set of the plurality of aggregate timeslot sets in the aggregate serialized data stream includes mapping data from a first timeslot from the first set of timeslots to a first timeslot in the first aggregate timeslot set of the plurality of aggregate timeslot sets, data from a first timeslot from the second set of timeslots to a second timeslot in the first aggregate timeslot set of the plurality of aggregate timeslot sets, data from a first timeslot from the third set of timeslots to a third timeslot in the first aggregate timeslot set of the plurality of aggregate timeslot sets, and data from a first timeslot from the fourth set of timeslots to a fourth timeslot in the first aggregate timeslot set of the plurality of aggregate timeslot sets; and wherein mapping data from a second timeslot from the set of timeslots for each different serialized data stream to the second aggregate timeslot set of the plurality of aggregate timeslot sets in the aggregate serialized data stream includes mapping data from a second timeslot from the first set of timeslots to a first timeslot in the second aggregate timeslot set of the plurality of aggregate timeslot sets, data from a second timeslot from the second set of timeslots to a second timeslot in the second aggregate timeslot set of the plurality of aggregate timeslot sets, data from a second timeslot from the third set of timeslots to a third timeslot in the second aggregate timeslot set of the plurality of aggregate timeslot sets, and data from a second timeslot from the fourth set of timeslots to a fourth timeslot in the second aggregate timeslot set of the plurality of aggregate timeslot sets.

**[0186]** Example 18 includes the method of any of Examples 15-17, wherein a third aggregate timeslot set of the plurality of aggregate timeslot sets comes after the second

aggregate timeslot set of the plurality of aggregate timeslot sets; and further interleaving data from the plurality of different serialized data streams by mapping data from a third timeslot from the set of timeslots for each different serialized data stream to the third aggregate timeslot set of the plurality of aggregate timeslot sets in the aggregate serialized data stream.

**[0187]** Example 19 includes the method of Example 18, wherein the plurality of different serialized data streams include at least a first serialized data stream having a first data rate and a first set of timeslots and a second serialized data stream having a second data rate and a second set of timeslots; wherein mapping data from a first timeslot from the set of timeslots for each different serialized data stream to the first aggregate timeslot set of the plurality of aggregate timeslot sets in the aggregate serialized data stream includes mapping data from a first timeslot from the first set of timeslots to a first timeslot in the first aggregate timeslot set of the plurality of aggregate timeslot sets and data from a first timeslot from the second set of timeslots to a second timeslot in the first aggregate timeslot set of the plurality of aggregate timeslot sets; wherein mapping data from a second timeslot from the set of timeslots for each different serialized data stream to the second aggregate timeslot set of the plurality of aggregate timeslot sets in the aggregate serialized data stream includes mapping data from a second timeslot from the first set of timeslots to a first timeslot in the second aggregate timeslot set of the plurality of aggregate timeslot sets and data from a second timeslot from the second set of timeslots to a second timeslot in the second aggregate timeslot set of the plurality of aggregate timeslot sets; and wherein mapping data from a third timeslot from the set of timeslots for each different serialized data stream to the third aggregate timeslot set of the plurality of aggregate timeslot sets in the aggregate serialized data stream includes mapping data from a third timeslot from the first set of timeslots to a first timeslot in the third aggregate timeslot set of the plurality of aggregate timeslot sets and data from a third timeslot from the second set of timeslots to a second timeslot in the third aggregate timeslot set of the plurality of aggregate timeslot sets.

**[0188]** Example 20 includes the method of any of Examples 18-19, wherein the plurality of different serialized data streams include a first serialized data stream having a first data rate and a first set of timeslots, a second serialized data stream having a second data rate and a second set of timeslots, a third serialized data stream having a third data rate and a third set of timeslots, and a fourth serialized data stream having a fourth data rate and a fourth set of timeslots; wherein mapping data from a first timeslot from the set of timeslots for each different serialized data stream to the first aggregate timeslot set of the plurality of aggregate timeslot sets in the aggregate serialized data stream includes mapping data from a first timeslot from the first set of timeslots to a first timeslot in the first aggregate timeslot set of the plurality of aggregate timeslot sets, data from a first timeslot from the second set of timeslots to a second timeslot in the first aggregate timeslot set of the plurality of aggregate timeslot sets, data from a first timeslot from the third set of timeslots to a third timeslot in the first aggregate timeslot set of the plurality of aggregate timeslot sets, and data from a first timeslot from the fourth set of timeslots to a fourth timeslot in the first aggregate timeslot set of the plurality of aggregate timeslot sets; wherein mapping data from a second timeslot from the set of timeslots for each different serialized data stream to the

second aggregate timeslot set of the plurality of aggregate timeslot sets in the aggregate serialized data stream includes mapping data from a second timeslot from the first set of timeslots to a first timeslot in the second aggregate timeslot set of the plurality of aggregate timeslot sets, data from a second timeslot from the second set of timeslots to a second timeslot in the second aggregate timeslot set of the plurality of aggregate timeslot sets, data from a second timeslot from the third set of timeslots to a third timeslot in the second aggregate timeslot set of the plurality of aggregate timeslot sets, and data from a second timeslot from the fourth set of timeslots to a fourth timeslot in the second aggregate timeslot set of the plurality of aggregate timeslot sets; and wherein mapping data from a third timeslot from the set of timeslots for each different serialized data stream to the third aggregate timeslot set of the plurality of aggregate timeslot sets in the aggregate serialized data stream includes mapping data from a third timeslot from the first set of timeslots to a first timeslot in the third aggregate timeslot set of the plurality of aggregate timeslot sets, data from a third timeslot from the second set of timeslots to a second timeslot in the third aggregate timeslot set of the plurality of aggregate timeslot sets, data from a third timeslot from the third set of timeslots to a third timeslot in the third aggregate timeslot set of the plurality of aggregate timeslot sets, and data from a third timeslot from the fourth set of timeslots to a fourth timeslot in the third aggregate timeslot set of the plurality of aggregate timeslot sets.

**[0189]** Example 21 includes the method of any of Examples 15-20, further comprising: wherein receiving the plurality of different serialized data streams includes receiving downlink serialized data streams from the plurality of different network interfaces across different first digital communication links; and wherein communicating the aggregate serialized data stream includes communicating the aggregate serialized data stream to a distributed antenna switch over a second digital communication link.

**[0190]** Example 22 includes the method of any of Examples 15-21, further comprising: receiving a second aggregate serialized data stream having a second aggregate data rate and a second plurality of aggregate timeslot sets, each set of the second plurality of aggregate timeslot sets coming sequentially in time, wherein a first aggregate timeslot set of the second plurality of aggregate timeslot sets comes before a second aggregate timeslot set of the second plurality of aggregate timeslot sets; communicating a different second serialized data stream having a second data rate and a second set of timeslots; and de-interleaving data from the second aggregate serialized data stream by mapping data from the first aggregate timeslot set of the second plurality of aggregate timeslot sets to a first timeslot from the second set of timeslots for each different serialized data stream and mapping data from the second aggregate timeslot set of the second plurality of aggregate timeslot sets to a second timeslot from the second set of timeslots for each different serialized data stream.

**[0191]** Example 23 includes the method of any of Examples 15-22, further comprising: communicating the aggregate serialized data stream at both a first aggregate serialized data stream interface and a second serialized data stream interface.

**[0192]** Example 24 includes the method of any of Examples 15-23, further comprising: receiving a second aggregate serialized data stream having a second aggregate data rate and a second plurality of aggregate timeslot sets,

each set of the second plurality of aggregate timeslot sets coming sequentially in time, wherein a second aggregate timeslot set of the second plurality of aggregate timeslot sets comes after a first aggregate timeslot set of the second plurality of aggregate timeslot sets; communicating a different second serialized data stream having a second data rate and a second set of timeslots; and de-interleaving data from the second aggregate serialized data stream by mapping data from the first aggregate timeslot set of the second plurality of aggregate timeslot sets to a first timeslot from the second set of timeslots for each different serialized data stream and mapping data from the second aggregate timeslot set of the second plurality of aggregate timeslot sets to a second timeslot from the second set of timeslots for each different serialized data stream.

**[0193]** Example 25 includes the method of any of Examples 15-24, further comprising: receiving a second aggregate serialized data stream having a second aggregate data rate and a second plurality of aggregate timeslot sets, each set of the second plurality of aggregate timeslot sets coming sequentially in time, wherein a second aggregate timeslot set of the second plurality of aggregate timeslot sets comes after a first aggregate timeslot set of the second plurality of aggregate timeslot sets; and digitally summing the second aggregate serialized data stream into the aggregate serialized data stream before communicating the aggregate serialized data stream.

**[0194]** Example 26 includes the method of Example 25, wherein digitally summing the second aggregate serialized data stream into the aggregate serialized data stream before communicating the aggregate serialized data stream includes summing data in each timeslot of the second aggregate serialized data stream into data in a corresponding timeslot of the aggregate serialized data stream, such that data in each timeslot in the first aggregate timeslot set of the second aggregate serialized data stream is summed into data in a corresponding timeslot in the first aggregate timeslot set of the aggregate serialized data stream and data in each timeslot in the second aggregate timeslot set of the second aggregate serialized data stream is summed into data in a corresponding timeslot in the second aggregate timeslot set of the aggregate serialized data stream.

**[0195]** Example 27 includes the method of any of Examples 15-26, wherein at least one of the different serialized data streams includes at least one of a serialized base-band data stream, a serialized intermediate frequency data stream, and a serialized radio frequency data stream corresponding to a radio frequency band communicated by a base station.

**[0196]** Example 28 includes the method of any of Examples 15-27, wherein the aggregate data rate is faster than the data rate.

**[0197]** Example 29 includes a serial link interface unit comprising: an aggregate serialized data stream interface configured to receive an aggregate serialized data stream having an aggregate data rate and a plurality of aggregate timeslot sets, each set of the plurality of aggregate timeslot sets coming sequentially in time, wherein a second aggregate timeslot set of the plurality of aggregate timeslot sets comes after a first aggregate timeslot set of the plurality of aggregate timeslot sets; a plurality of serialized data stream interfaces, each of the plurality of serialized data stream interfaces configured to communicate a different serialized data stream having a data rate and a set of timeslots; and wherein the serial

link interface unit is configured to de-interleave data from the aggregate serialized data stream received at the aggregate serialized data stream interface by being configured to map data from the first aggregate timeslot set of the plurality of aggregate timeslot sets to a first timeslot from the set of timeslots for each different serialized data stream and being configured to map data from the second aggregate timeslot set of the plurality of aggregate timeslot sets to a second timeslot from the set of timeslots for each different serialized data stream.

**[0198]** Example 30 includes the serial link interface unit of Example 29, wherein the different serialized data streams include at least a first serialized data stream having a first data rate and a first set of timeslots and a second serialized data stream having a second data rate and a second set of timeslots; wherein being configured to map data from the first aggregate timeslot set of the plurality of aggregate timeslot sets to a first timeslot from the set of timeslots for each different serialized data stream includes being configured to map data from a first timeslot in the first aggregate timeslot set of the plurality of aggregate timeslot sets to a first timeslot from the first set of timeslots and data from a second timeslot in the first aggregate timeslot set of the plurality of aggregate timeslot sets to a first timeslot from the second set of timeslots; and wherein being configured to map data from the second aggregate timeslot set of the plurality of aggregate timeslot sets to a second timeslot from the set of timeslots for each different serialized data stream includes being configured to map data from a first timeslot in the second aggregate timeslot set of the plurality of aggregate timeslot sets to a second timeslot from the first set of timeslots and data from a second timeslot in the second aggregate timeslot set of the plurality of aggregate timeslot sets to a second timeslot from the second set of timeslots.

**[0199]** Example 31 includes the serial link interface unit of any of Examples 29-30, wherein the different serialized data streams include at least a first serialized data stream having a first data rate and a first set of timeslots, a second serialized data stream having a second data rate and a second set of timeslots, a third serialized data stream having a third data rate and a third set of timeslots, and a fourth serialized data stream having a fourth data rate and a fourth set of timeslots; wherein being configured to map data from the first aggregate timeslot set of the plurality of aggregate timeslot sets to a first timeslot from the set of timeslots for each different serialized data stream includes being configured to map data from a first timeslot in the first aggregate timeslot set of the plurality of aggregate timeslot sets to a first timeslot from the first set of timeslots, data from a second timeslot in the first aggregate timeslot set of the plurality of aggregate timeslot sets to a first timeslot from the second set of timeslots, data from a third timeslot in the first aggregate timeslot set of the plurality of aggregate timeslot sets to a first timeslot from the third set of timeslots, and data from a fourth timeslot in the first aggregate timeslot set of the plurality of aggregate timeslot sets to a first timeslot from the fourth set of timeslots; and wherein being configured to map data from the second aggregate timeslot set of the plurality of aggregate timeslot sets to a second timeslot from the set of timeslots for each different serialized data stream includes being configured to map data from a first timeslot in the second aggregate timeslot set of the plurality of aggregate timeslot sets to a second timeslot from the first set of timeslots, data from a second timeslot in the second aggregate timeslot set of the plurality of aggregate timeslot sets to a second timeslot from the second set of timeslots, data from a third timeslot in the second aggregate timeslot set of the plurality of aggregate timeslot sets to a second timeslot from the third set of timeslots, and data from a fourth timeslot in the second aggregate timeslot set of the plurality of aggregate timeslot sets to a second timeslot from the fourth set of timeslots.

a second timeslot from the second set of timeslots, data from a third timeslot in the second aggregate timeslot set of the plurality of aggregate timeslot sets to a second timeslot from the third set of timeslots, and data from a fourth timeslot in the second aggregate timeslot set of the plurality of aggregate timeslot sets to a second timeslot from the fourth set of timeslots.

**[0200]** Example 32 includes the serial link interface unit of any of Examples 29-31, wherein a third aggregate timeslot set of the plurality of aggregate timeslot sets comes after the second aggregate timeslot set of the plurality of aggregate timeslot sets; and wherein the serial link interface unit is further configured to de-interleave data from the aggregate serialized data stream received at the aggregate serialized data stream interface by being configured to map data from the third aggregate timeslot set of the plurality of aggregate timeslot sets to a third timeslot from the set of timeslots for each different serialized data stream and being configured to map data from the second aggregate timeslot set of the plurality of aggregate timeslot sets to a second timeslot from the set of timeslots for each different serialized data stream.

**[0201]** Example 33 includes the serial link interface unit of Example 32, wherein the different serialized data streams include at least a first serialized data stream having a first data rate and a first set of timeslots and a second serialized data stream having a second data rate and a second set of timeslots; wherein being configured to map data from the first aggregate timeslot set of the plurality of aggregate timeslot sets to a first timeslot from the set of timeslots for each different serialized data stream includes being configured to map data from a first timeslot in the first aggregate timeslot set of the plurality of aggregate timeslot sets to a first timeslot from the first set of timeslots and data from a second timeslot in the first aggregate timeslot set of the plurality of aggregate timeslot sets to a first timeslot from the second set of timeslots; wherein being configured to map data from the second aggregate timeslot set of the plurality of aggregate timeslot sets to a second timeslot from the set of timeslots for each different serialized data stream includes being configured to map data from a first timeslot in the second aggregate timeslot set of the plurality of aggregate timeslot sets to a second timeslot from the first set of timeslots and data from a second timeslot in the second aggregate timeslot set of the plurality of aggregate timeslot sets to a second timeslot from the second set of timeslots; and wherein being configured to map data from the third aggregate timeslot set of the plurality of aggregate timeslot sets to a third timeslot from the set of timeslots for each different serialized data stream includes being configured to map data from a first timeslot in the third aggregate timeslot set of the plurality of aggregate timeslot sets to a third timeslot from the first set of timeslots and data from a second timeslot in the third aggregate timeslot set of the plurality of aggregate timeslot sets to a third timeslot from the second set of timeslots.

**[0202]** Example 34 includes the serial link interface unit of any of Examples 32-33, wherein the different serialized data streams include at least a first serialized data stream having a first data rate and a first set of timeslots, a second serialized data stream having a second data rate and a second set of timeslots, a third serialized data stream having a third data rate and a third set of timeslots, and a fourth serialized data stream having a fourth data rate and a fourth set of timeslots; wherein being configured to map data from the first aggregate timeslot set of the plurality of aggregate timeslot sets to a first

timeslot from the set of timeslots for each different serialized data stream includes being configured to map data from a first timeslot in the first aggregate timeslot set of the plurality of aggregate timeslot sets to a first timeslot from the first set of timeslots, data from a second timeslot in the first aggregate timeslot set of the plurality of aggregate timeslot sets to a first timeslot from the second set of timeslots, data from a third timeslot in the first aggregate timeslot set of the plurality of aggregate timeslot sets to a first timeslot from the third set of timeslots, and data from a fourth timeslot in the first aggregate timeslot set of the plurality of aggregate timeslot sets to a first timeslot from the fourth set of timeslots; wherein being configured to map data from the second aggregate timeslot set of the plurality of aggregate timeslot sets to a second timeslot from the set of timeslots for each different serialized data stream includes being configured to map data from a first timeslot in the second aggregate timeslot set of the plurality of aggregate timeslot sets to a second timeslot from the first set of timeslots, data from a second timeslot in the second aggregate timeslot set of the plurality of aggregate timeslot sets to a second timeslot from the second set of timeslots, data from a third timeslot in the second aggregate timeslot set of the plurality of aggregate timeslot sets to a second timeslot from the third set of timeslots, and data from a fourth timeslot in the second aggregate timeslot set of the plurality of aggregate timeslot sets to a second timeslot from the fourth set of timeslots; and wherein being configured to map data from the third aggregate timeslot set of the plurality of aggregate timeslot sets to a third timeslot from the set of timeslots for each different serialized data stream includes being configured to map data from a first timeslot in the third aggregate timeslot set of the plurality of aggregate timeslot sets to a third timeslot from the first set of timeslots, data from a second timeslot in the third aggregate timeslot set of the plurality of aggregate timeslot sets to a third timeslot from the second set of timeslots, data from a third timeslot in the third aggregate timeslot set of the plurality of aggregate timeslot sets to a third timeslot from the third set of timeslots, and data from a fourth timeslot in the third aggregate timeslot set of the plurality of aggregate timeslot sets to a third timeslot from the fourth set of timeslots.

**[0203]** Example 35 includes the serial link interface unit of any of Examples 32-34, further comprising: a second aggregate serialized data stream interface configured to communicate the aggregate serialized data stream.

**[0204]** Example 36 includes the serial link interface unit of any of Examples 32-35, wherein at least one of the different serialized data streams includes at least one of a serialized baseband data stream, a serialized intermediate frequency data stream, and a serialized radio frequency data stream corresponding to a radio frequency band communicated by a base station.

**[0205]** Example 37 includes the serial link interface unit of any of Examples 32-36, wherein the aggregate data rate is faster than the data rate.

**[0206]** Example 38 includes a method of splitting apart an aggregate serialized data stream into a plurality of serialized data streams, the method comprising: receiving an aggregate serialized data stream having an aggregate data rate and a plurality of aggregate timeslot sets, each set of the plurality of aggregate timeslot sets coming sequentially in time, wherein a second aggregate timeslot set of the plurality of aggregate timeslot sets comes after a first aggregate timeslot set of the plurality of aggregate timeslot sets; communicating a plural-



from a third timeslot in the first aggregate timeslot set of the plurality of aggregate timeslot sets to a first timeslot from the third set of timeslots, and data from a fourth timeslot in the first aggregate timeslot set of the plurality of aggregate timeslot sets to a first timeslot from the fourth set of timeslots; wherein mapping data from the second aggregate timeslot set of the plurality of aggregate timeslot sets to a second timeslot from the set of timeslots for each different serialized data stream includes mapping data from a first timeslot in the second aggregate timeslot set of the plurality of aggregate timeslot sets to a second timeslot from the first set of timeslots, data from a second timeslot in the second aggregate timeslot set of the plurality of aggregate timeslot sets to a second timeslot from the second set of timeslots, data from a third timeslot in the second aggregate timeslot set of the plurality of aggregate timeslot sets to a second timeslot from the third set of timeslots, and data from a fourth timeslot in the second aggregate timeslot set of the plurality of aggregate timeslot sets to a second timeslot from the fourth set of timeslots; and wherein mapping data from the third aggregate timeslot set of the plurality of aggregate timeslot sets to a third timeslot from the set of timeslots for each different serialized data stream includes mapping data from a first timeslot in the third aggregate timeslot set of the plurality of aggregate timeslot sets to a third timeslot from the first set of timeslots, data from a second timeslot in the third aggregate timeslot set of the plurality of aggregate timeslot sets to a third timeslot from the second set of timeslots, data from a third timeslot in the third aggregate timeslot set of the plurality of aggregate timeslot sets to a third timeslot from the third set of timeslots, and data from a fourth timeslot in the third aggregate timeslot set of the plurality of aggregate timeslot sets to a third timeslot from the fourth set of timeslots.

[0212] Example 44 includes the method of any of Examples 41-43, wherein at least one of the different serialized data streams includes at least one of a serialized base-band data stream, a serialized intermediate frequency data stream, and a serialized radio frequency data stream corresponding to a radio frequency band communicated by a base station.

[0213] Example 45 includes the method of any of Examples 41-44, wherein the aggregate data rate is faster than the data rate.

What is claimed is:

1. A serial link interface unit comprising:

a plurality of serialized data stream interfaces, each of the plurality of serialized data stream interfaces configured to receive a different serialized data stream having a data rate and a set of timeslots;

an aggregate serialized data stream interface configured to communicate an aggregate serialized data stream having an aggregate data rate and a plurality of aggregate timeslot sets, each set of the plurality of aggregate timeslot sets coming sequentially in time, wherein a second aggregate timeslot set of the plurality of aggregate timeslot sets comes after a first aggregate timeslot set of the plurality of aggregate timeslot sets; and

wherein the serial link interface unit is configured to interleave data from the different serialized data streams received at the plurality of first interfaces by being configured to map data from a first timeslot from the set of timeslots for each different serialized data stream to the first aggregate timeslot set of the plurality of aggregate timeslot sets in the aggregate serialized data stream and

being configured to map data from a second timeslot from the set of timeslots for each different serialized data stream to the second aggregate timeslot set of the plurality of aggregate timeslot sets in the aggregate serialized data stream.

2. The serial link interface unit of claim 1, wherein the different serialized data streams include at least a first serialized data stream having a first data rate and a first set of timeslots and a second serialized data stream having a second data rate and a second set of timeslots;

wherein being configured to map data from a first timeslot from the set of timeslots for each different serialized data stream to the first aggregate timeslot set of the plurality of aggregate timeslot sets in the aggregate serialized data stream includes being configured to map data from a first timeslot from the first set of timeslots to a first timeslot in the first aggregate timeslot set of the plurality of aggregate timeslot sets and data from a first timeslot from the second set of timeslots to a second timeslot in the first aggregate timeslot set of the plurality of aggregate timeslot sets; and

wherein being configured to map data from a second timeslot from the set of timeslots for each different serialized data stream to the second aggregate timeslot set of the plurality of aggregate timeslot sets in the aggregate serialized data stream includes being configured to map data from a second timeslot from the first set of timeslots to a first timeslot in the second aggregate timeslot set of the plurality of aggregate timeslot sets and data from a second timeslot from the second set of timeslots to a second timeslot in the second aggregate timeslot set of the plurality of aggregate timeslot sets.

3. The serial link interface unit of claim 1, wherein the different serialized data streams include a first serialized data stream having a first data rate and a first set of timeslots, a second serialized data stream having a second data rate and a second set of timeslots, a third serialized data stream having a third data rate and a third set of timeslots, and a fourth serialized data stream having a fourth data rate and a fourth set of timeslots;

wherein being configured to map data from a first timeslot from the set of timeslots for each different serialized data stream to the first aggregate timeslot set of the plurality of aggregate timeslot sets in the aggregate serialized data stream includes being configured to map data from a first timeslot from the first set of timeslots to a first timeslot in the first aggregate timeslot set of the plurality of aggregate timeslot sets, data from a first timeslot from the second set of timeslots to a second timeslot in the first aggregate timeslot set of the plurality of aggregate timeslot sets, data from a first timeslot from the third set of timeslots to a third timeslot in the first aggregate timeslot set of the plurality of aggregate timeslot sets, and data from a first timeslot from the fourth set of timeslots to a fourth timeslot in the first aggregate timeslot set of the plurality of aggregate timeslot sets; and

wherein being configured to map data from a second timeslot from the set of timeslots for each different serialized data stream to the second aggregate timeslot set of the plurality of aggregate timeslot sets in the aggregate serialized data stream includes being configured to map data from a second timeslot from the first set of timeslots to a first timeslot in the second aggregate timeslot set of

the plurality of aggregate timeslot sets, data from a second timeslot from the second set of timeslots to a second timeslot in the second aggregate timeslot set of the plurality of aggregate timeslot sets, data from a second timeslot from the third set of timeslots to a third timeslot in the second aggregate timeslot set of the plurality of aggregate timeslot sets, and data from a second timeslot from the fourth set of timeslots to a fourth timeslot in the second aggregate timeslot set of the plurality of aggregate timeslot sets.

4. The serial link interface unit of claim 1, wherein a third aggregate timeslot set of the plurality of aggregate timeslot sets comes after the second aggregate timeslot set of the plurality of aggregate timeslot sets; and

wherein the serial link interface unit is further configured to interleave data from the different serialized data streams received at the plurality of first interfaces by being configured to map data from a third timeslot from the set of timeslots for each different serialized data stream to the third aggregate timeslot set of the plurality of aggregate timeslot sets in the aggregate serialized data stream.

5. The serial link interface unit of claim 4, wherein the different serialized data streams include at least a first serialized data stream having a first data rate and a first set of timeslots and a second serialized data stream having a second data rate and a second set of timeslots;

wherein being configured to map data from a first timeslot from the set of timeslots for each different serialized data stream to the first aggregate timeslot set of the plurality of aggregate timeslot sets in the aggregate serialized data stream includes being configured to map data from a first timeslot from the first set of timeslots to a first timeslot in the first aggregate timeslot set of the plurality of aggregate timeslot sets and data from a first timeslot from the second set of timeslots to a second timeslot in the first aggregate timeslot set of the plurality of aggregate timeslot sets;

wherein being configured to map data from a second timeslot from the set of timeslots for each different serialized data stream to the second aggregate timeslot set of the plurality of aggregate timeslot sets in the aggregate serialized data stream includes being configured to map data from a second timeslot from the first set of timeslots to a first timeslot in the second aggregate timeslot set of the plurality of aggregate timeslot sets and data from a second timeslot from the second set of timeslots to a second timeslot in the second aggregate timeslot set of the plurality of aggregate timeslot sets; and

wherein being configured to map data from a third timeslot from the set of timeslots for each different serialized data stream to the third aggregate timeslot set of the plurality of aggregate timeslot sets in the aggregate serialized data stream includes being configured to map data from a third timeslot from the first set of timeslots to a first timeslot in the third aggregate timeslot set of the plurality of aggregate timeslot sets and data from a third timeslot from the second set of timeslots to a second timeslot in the third aggregate timeslot set of the plurality of aggregate timeslot sets.

6. The serial link interface unit of claim 4, wherein the different serialized data streams include a first serialized data stream having a first data rate and a first set of timeslots, a second serialized data stream having a second data rate and a second set of timeslots, a third serialized data stream having

a third data rate and a third set of timeslots, and a fourth serialized data stream having a fourth data rate and a fourth set of timeslots;

wherein being configured to map data from a first timeslot from the set of timeslots for each different serialized data stream to the first aggregate timeslot set of the plurality of aggregate timeslot sets in the aggregate serialized data stream includes being configured to map data from a first timeslot from the first set of timeslots to a first timeslot in the first aggregate timeslot set of the plurality of aggregate timeslot sets, data from a first timeslot from the second set of timeslots to a second timeslot in the first aggregate timeslot set of the plurality of aggregate timeslot sets, data from a first timeslot from the third set of timeslots to a third timeslot in the first aggregate timeslot set of the plurality of aggregate timeslot sets, and data from a first timeslot from the fourth set of timeslots to a fourth timeslot in the first aggregate timeslot set of the plurality of aggregate timeslot sets;

wherein being configured to map data from a second timeslot from the set of timeslots for each different serialized data stream to the second aggregate timeslot set of the plurality of aggregate timeslot sets in the aggregate serialized data stream includes being configured to map data from a second timeslot from the first set of timeslots to a first timeslot in the second aggregate timeslot set of the plurality of aggregate timeslot sets, data from a second timeslot from the second set of timeslots to a second timeslot in the second aggregate timeslot set of the plurality of aggregate timeslot sets, data from a second timeslot from the third set of timeslots to a third timeslot in the second aggregate timeslot set of the plurality of aggregate timeslot sets, and data from a second timeslot from the fourth set of timeslots to a fourth timeslot in the second aggregate timeslot set of the plurality of aggregate timeslot sets; and

wherein being configured to map data from a third timeslot from the set of timeslots for each different serialized data stream to the third aggregate timeslot set of the plurality of aggregate timeslot sets in the aggregate serialized data stream includes being configured to map data from a third timeslot from the first set of timeslots to a first timeslot in the third aggregate timeslot set of the plurality of aggregate timeslot sets, data from a third timeslot from the second set of timeslots to a second timeslot in the third aggregate timeslot set of the plurality of aggregate timeslot sets, data from a third timeslot from the third set of timeslots to a third timeslot in the third aggregate timeslot set of the plurality of aggregate timeslot sets, and data from a third timeslot from the fourth set of timeslots to a fourth timeslot in the third aggregate timeslot set of the plurality of aggregate timeslot sets.

7. The serial link interface unit of claim 1, further comprising:

wherein the serial link interface unit is used in a distributed antenna system;

wherein the plurality of serialized data stream interfaces are configured to receive downlink serialized data streams from a different network interface across a different first digital communication link; and

wherein the aggregate serialized data stream interface is configured to communicate the aggregate serialized data



stream to a distributed antenna switch over a second digital communication link.

**8.** The serial link interface unit of claim **1**, further comprising:

wherein the aggregate serialized data stream interface is further configured to receive a second aggregate serialized data stream having a second aggregate data rate and a second plurality of aggregate timeslot sets, each set of the second plurality of aggregate timeslot sets coming sequentially in time, wherein a first aggregate timeslot set of the second plurality of aggregate timeslot sets comes before a second aggregate timeslot set of the second plurality of aggregate timeslot sets;

wherein the plurality of serialized data stream interfaces are each further configured to communicate a different second serialized data stream having a second data rate and a second set of timeslots; and

wherein the serial link interface unit is further configured to de-interleave data from the second aggregate serialized data stream by being further configured to map data from the first aggregate timeslot set of the second plurality of aggregate timeslot sets to a first timeslot from the second set of timeslots for each different serialized data stream and being configured to map data from the second aggregate timeslot set of the second plurality of aggregate timeslot sets to a second timeslot from the second set of timeslots for each different serialized data stream.

**9.** The serial link interface unit of claim **1**, further comprising:

a second aggregate serialized data stream interface configured to communicate the aggregate serialized data stream.

**10.** The serial link interface unit of claim **1**, further comprising:

a second aggregate serialized data stream interface configured to receive a second aggregate serialized data stream having a second aggregate data rate and a second plurality of aggregate timeslot sets, each set of the second plurality of aggregate timeslot sets coming sequentially in time, wherein a first aggregate timeslot set of the second plurality of aggregate timeslot sets comes before a second aggregate timeslot set of the second plurality of aggregate timeslot sets;

wherein the plurality of serialized data stream interfaces are each further configured to communicate a different second serialized data stream having a second data rate and a second set of timeslots; and

wherein the serial link interface unit is further configured to de-interleave data from the second aggregate serialized data stream by being further configured to map data from the first aggregate timeslot set of the second plurality of aggregate timeslot sets to a first timeslot from the second set of timeslots for each different serialized data stream and being configured to map data from the second aggregate timeslot set of the second plurality of aggregate timeslot sets to a second timeslot from the second set of timeslots for each different serialized data stream.

**11.** The serial link interface unit of claim **1**, further comprising:

a second aggregate serialized data stream interface configured to receive a second aggregate serialized data stream having a second aggregate data rate and a second plu-

rality of aggregate timeslot sets, each set of the second plurality of aggregate timeslot sets coming sequentially in time, wherein a second aggregate timeslot set of the second plurality of aggregate timeslot sets comes after a first aggregate timeslot set of the second plurality of aggregate timeslot sets; and

wherein the serial link interface unit is further configured to digitally sum the second aggregate serialized data stream into the aggregate serialized data stream before communicating the aggregate serialized data stream.

**12.** The serial link interface unit of claim **11**, further comprising:

wherein the serial link interface unit is configured to digitally sum the second aggregate serialized data stream into the aggregate serialized data stream before communicating the aggregate serialized data stream by being configured to sum data in each timeslot of the second aggregate serialized data stream into data in a corresponding timeslot of the aggregate serialized data stream, such that data in each timeslot in the first aggregate timeslot set of the second aggregate serialized data stream is summed into data in a corresponding timeslot in the first aggregate timeslot set of the aggregate serialized data stream and data in each timeslot in the second aggregate timeslot set of the second aggregate serialized data stream is summed into data in a corresponding timeslot in the second aggregate timeslot set of the aggregate serialized data stream.

**13.** The serial link interface unit of claim **1**, wherein at least one of the different serialized data streams includes at least one of a serialized baseband data stream, a serialized intermediate frequency data stream, and a serialized radio frequency data stream corresponding to a radio frequency band communicated by a base station.

**14.** The serial link interface unit of claim **1**, wherein the aggregate data rate is faster than the data rate.

**15.** A method of aggregating a plurality of serialized data streams into an aggregate serialized data stream, the method comprising:

receiving a plurality of different serialized data streams each having a data rate and a set of timeslots;

communicating an aggregate serialized data stream having an aggregate data rate and a plurality of aggregate timeslot sets, each set of the plurality of aggregate timeslot sets coming sequentially in time, wherein a second aggregate timeslot set of the plurality of aggregate timeslot sets comes after a first aggregate timeslot set of the plurality of aggregate timeslot sets; and

interleaving data from the plurality of different serialized data streams by mapping data from a first timeslot from the set of timeslots for each different serialized data stream to the first aggregate timeslot set of the plurality of aggregate timeslot sets in the aggregate serialized data stream and mapping data from a second timeslot from the set of timeslots for each different serialized data stream to the second aggregate timeslot set of the plurality of aggregate timeslot sets in the aggregate serialized data stream.

**16.** The method of claim **15**, wherein the plurality of different serialized data streams include at least a first serialized data stream having a first data rate and a first set of timeslots and a second serialized data stream having a second data rate and a second set of timeslots;





timeslot from the third set of timeslots to a third timeslot in the first aggregate timeslot set of the plurality of aggregate timeslot sets, and data from a first timeslot from the fourth set of timeslots to a fourth timeslot in the first aggregate timeslot set of the plurality of aggregate timeslot sets;

wherein mapping data from a second timeslot from the set of timeslots for each different serialized data stream to the second aggregate timeslot set of the plurality of aggregate timeslot sets in the aggregate serialized data stream includes mapping data from a second timeslot from the first set of timeslots to a first timeslot in the second aggregate timeslot set of the plurality of aggregate timeslot sets, data from a second timeslot from the second set of timeslots to a second timeslot in the second aggregate timeslot set of the plurality of aggregate timeslot sets, data from a second timeslot from the third set of timeslots to a third timeslot in the second aggregate timeslot set of the plurality of aggregate timeslot sets, and data from a second timeslot from the fourth set of timeslots to a fourth timeslot in the second aggregate timeslot set of the plurality of aggregate timeslot sets; and

wherein mapping data from a third timeslot from the set of timeslots for each different serialized data stream to the third aggregate timeslot set of the plurality of aggregate timeslot sets in the aggregate serialized data stream includes mapping data from a third timeslot from the first set of timeslots to a first timeslot in the third aggregate timeslot set of the plurality of aggregate timeslot sets, data from a third timeslot from the second set of timeslots to a second timeslot in the third aggregate timeslot set of the plurality of aggregate timeslot sets, data from a third timeslot from the third set of timeslots to a third timeslot in the third aggregate timeslot set of the plurality of aggregate timeslot sets, and data from a third timeslot from the fourth set of timeslots to a fourth timeslot in the third aggregate timeslot set of the plurality of aggregate timeslot sets.

**21.** The method of claim **15**, further comprising:

wherein receiving the plurality of different serialized data streams includes receiving downlink serialized data streams from the plurality of different network interfaces across different first digital communication links; and

wherein communicating the aggregate serialized data stream includes communicating the aggregate serialized data stream to a distributed antenna switch over a second digital communication link.

**22.** The method of claim **15**, further comprising:

receiving a second aggregate serialized data stream having a second aggregate data rate and a second plurality of aggregate timeslot sets, each set of the second plurality of aggregate timeslot sets coming sequentially in time, wherein a first aggregate timeslot set of the second plurality of aggregate timeslot sets comes before a second aggregate timeslot set of the second plurality of aggregate timeslot sets;

communicating a different second serialized data stream having a second data rate and a second set of timeslots; and

de-interleaving data from the second aggregate serialized data stream by mapping data from the first aggregate timeslot set of the second plurality of aggregate timeslot

sets to a first timeslot from the second set of timeslots for each different serialized data stream and mapping data from the second aggregate timeslot set of the second plurality of aggregate timeslot sets to a second timeslot from the second set of timeslots for each different serialized data stream.

**23.** The method of claim **15**, further comprising:

communicating the aggregate serialized data stream at both a first aggregate serialized data stream interface and a second serialized data stream interface.

**24.** The method of claim **15**, further comprising:

receiving a second aggregate serialized data stream having a second aggregate data rate and a second plurality of aggregate timeslot sets, each set of the second plurality of aggregate timeslot sets coming sequentially in time, wherein a second aggregate timeslot set of the second plurality of aggregate timeslot sets comes after a first aggregate timeslot set of the second plurality of aggregate timeslot sets;

communicating a different second serialized data stream having a second data rate and a second set of timeslots; and

de-interleaving data from the second aggregate serialized data stream by mapping data from the first aggregate timeslot set of the second plurality of aggregate timeslot sets to a first timeslot from the second set of timeslots for each different serialized data stream and mapping data from the second aggregate timeslot set of the second plurality of aggregate timeslot sets to a second timeslot from the second set of timeslots for each different serialized data stream.

**25.** The method of claim **15**, further comprising:

receiving a second aggregate serialized data stream having a second aggregate data rate and a second plurality of aggregate timeslot sets, each set of the second plurality of aggregate timeslot sets coming sequentially in time, wherein a second aggregate timeslot set of the second plurality of aggregate timeslot sets comes after a first aggregate timeslot set of the second plurality of aggregate timeslot sets; and

digitally summing the second aggregate serialized data stream into the aggregate serialized data stream before communicating the aggregate serialized data stream.

**26.** The method of claim **25**, wherein digitally summing the second aggregate serialized data stream into the aggregate serialized data stream before communicating the aggregate serialized data stream includes summing data in each timeslot of the second aggregate serialized data stream into data in a corresponding timeslot of the aggregate serialized data stream, such that data in each timeslot in the first aggregate timeslot set of the second aggregate serialized data stream is summed into data in a corresponding timeslot in the first aggregate timeslot set of the aggregate serialized data stream and data in each timeslot in the second aggregate timeslot set of the second aggregate serialized data stream is summed into data in a corresponding timeslot in the second aggregate timeslot set of the aggregate serialized data stream.

**27.** The method of claim **15**, wherein at least one of the different serialized data streams includes at least one of a serialized baseband data stream, a serialized intermediate frequency data stream, and a serialized radio frequency data stream corresponding to a radio frequency band communicated by a base station.



rality of aggregate timeslot sets to a second timeslot from the first set of timeslots and data from a second timeslot in the second aggregate timeslot set of the plurality of aggregate timeslot sets to a second timeslot from the second set of timeslots; and

wherein being configured to map data from the third aggregate timeslot set of the plurality of aggregate timeslot sets to a third timeslot from the set of timeslots for each different serialized data stream includes being configured to map data from a first timeslot in the third aggregate timeslot set of the plurality of aggregate timeslot sets to a third timeslot from the first set of timeslots and data from a second timeslot in the third aggregate timeslot set of the plurality of aggregate timeslot sets to a third timeslot from the second set of timeslots.

**34.** The serial link interface unit of claim **32**, wherein the different serialized data streams include at least a first serialized data stream having a first data rate and a first set of timeslots, a second serialized data stream having a second data rate and a second set of timeslots, a third serialized data stream having a third data rate and a third set of timeslots, and a fourth serialized data stream having a fourth data rate and a fourth set of timeslots;

wherein being configured to map data from the first aggregate timeslot set of the plurality of aggregate timeslot sets to a first timeslot from the set of timeslots for each different serialized data stream includes being configured to map data from a first timeslot in the first aggregate timeslot set of the plurality of aggregate timeslot sets to a first timeslot from the first set of timeslots, data from a second timeslot in the first aggregate timeslot set of the plurality of aggregate timeslot sets to a first timeslot from the second set of timeslots, data from a third timeslot in the first aggregate timeslot set of the plurality of aggregate timeslot sets to a first timeslot from the third set of timeslots, and data from a fourth timeslot in the first aggregate timeslot set of the plurality of aggregate timeslot sets to a first timeslot from the fourth set of timeslots;

wherein being configured to map data from the second aggregate timeslot set of the plurality of aggregate timeslot sets to a second timeslot from the set of timeslots for each different serialized data stream includes being configured to map data from a first timeslot in the second aggregate timeslot set of the plurality of aggregate timeslot sets to a second timeslot from the first set of timeslots, data from a second timeslot in the second aggregate timeslot set of the plurality of aggregate timeslot sets to a second timeslot from the second set of timeslots, data from a third timeslot in the second aggregate timeslot set of the plurality of aggregate timeslot sets to a second timeslot from the third set of timeslots, and data from a fourth timeslot in the second aggregate timeslot set of the plurality of aggregate timeslot sets to a second timeslot from the fourth set of timeslots; and

wherein being configured to map data from the third aggregate timeslot set of the plurality of aggregate timeslot sets to a third timeslot from the set of timeslots for each different serialized data stream includes being configured to map data from a first timeslot in the third aggregate timeslot set of the plurality of aggregate timeslot sets to a third timeslot from the first set of timeslots, data from a second timeslot in the third aggregate timeslot set

of the plurality of aggregate timeslot sets to a third timeslot from the second set of timeslots, data from a third timeslot in the third aggregate timeslot set of the plurality of aggregate timeslot sets to a third timeslot from the third set of timeslots, and data from a fourth timeslot in the third aggregate timeslot set of the plurality of aggregate timeslot sets to a third timeslot from the fourth set of timeslots.

**35.** The serial link interface unit of claim **32**, further comprising:

a second aggregate serialized data stream interface configured to communicate the aggregate serialized data stream.

**36.** The serial link interface unit of claim **32**, wherein at least one of the different serialized data streams includes at least one of a serialized baseband data stream, a serialized intermediate frequency data stream, and a serialized radio frequency data stream corresponding to a radio frequency band communicated by a base station.

**37.** The serial link interface unit of claim **32**, wherein the aggregate data rate is faster than the data rate.

**38.** A method of splitting apart an aggregate serialized data stream into a plurality of serialized data streams, the method comprising:

receiving an aggregate serialized data stream having an aggregate data rate and a plurality of aggregate timeslot sets, each set of the plurality of aggregate timeslot sets coming sequentially in time, wherein a second aggregate timeslot set of the plurality of aggregate timeslot sets comes after a first aggregate timeslot set of the plurality of aggregate timeslot sets;

communicating a plurality of different serialized data streams each having a data rate and a set of timeslots; and

de-interleaving data from the aggregate serialized data stream by mapping data from the first aggregate timeslot set of the plurality of aggregate timeslot sets to a first timeslot from the set of timeslots for each different serialized data stream and mapping data from the second aggregate timeslot set of the plurality of aggregate timeslot sets to a second timeslot from the set of timeslots for each different serialized data stream.

**39.** The method of claim **38**, wherein the plurality of different serialized data streams include at least a first serialized data stream having a first data rate and a first set of timeslots and a second serialized data stream having a second data rate and a second set of timeslots;

wherein mapping data from the first aggregate timeslot set of the plurality of aggregate timeslot sets to a first timeslot from the set of timeslots for each different serialized data stream includes mapping data from a first timeslot in the first aggregate timeslot set of the plurality of aggregate timeslot sets to a first timeslot from the first set of timeslots and data from a second timeslot in the first aggregate timeslot set of the plurality of aggregate timeslot sets to a first timeslot from the second set of timeslots; and

wherein mapping data from the second aggregate timeslot set of the plurality of aggregate timeslot sets to a second timeslot from the set of timeslots for each different serialized data stream includes mapping data from a first timeslot in the second aggregate timeslot set of the plurality of aggregate timeslot sets to a second timeslot from the first set of timeslots and data from a second



rality of aggregate timeslot sets to a second timeslot from the fourth set of timeslots; and wherein mapping data from the third aggregate timeslot set of the plurality of aggregate timeslot sets to a third timeslot from the set of timeslots for each different serialized data stream includes mapping data from a first timeslot in the third aggregate timeslot set of the plurality of aggregate timeslot sets to a third timeslot from the first set of timeslots, data from a second timeslot in the third aggregate timeslot set of the plurality of aggregate timeslot sets to a third timeslot from the second set of timeslots, data from a third timeslot in the third aggregate timeslot set of the plurality of aggregate timeslot sets to a third timeslot from the third set of timeslots, and data from a fourth timeslot in the third aggregate timeslot set of the plurality of aggregate timeslot sets to a third timeslot from the fourth set of timeslots.

**44.** The method of claim **41**, wherein at least one of the different serialized data streams includes at least one of a serialized baseband data stream, a serialized intermediate frequency data stream, and a serialized radio frequency data stream corresponding to a radio frequency band communicated by a base station.

**45.** The method of claim **41**, wherein the aggregate data rate is faster than the data rate.

\* \* \* \* \*