

P. SCHOEN.
MACHINE FOR SEWING ON BUTTONS.

No. 487,972.

Patented Dec. 13, 1892.

FIG. 2.

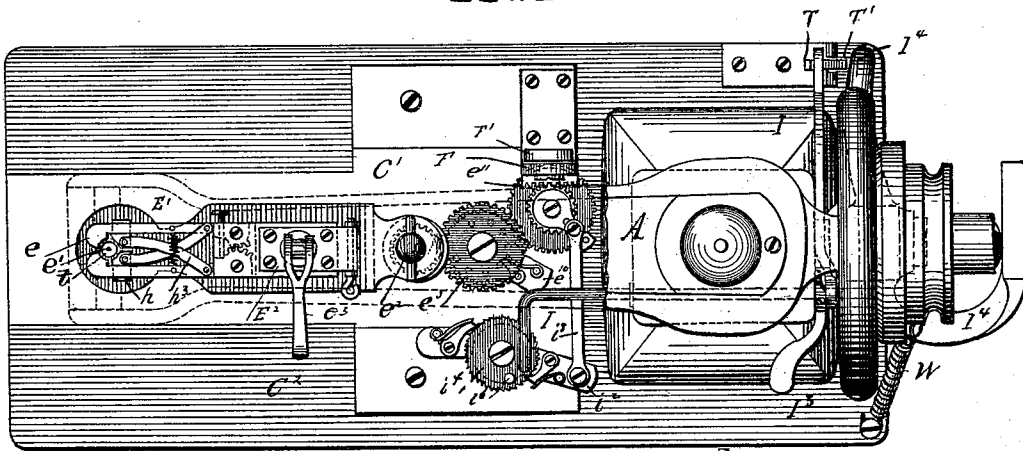
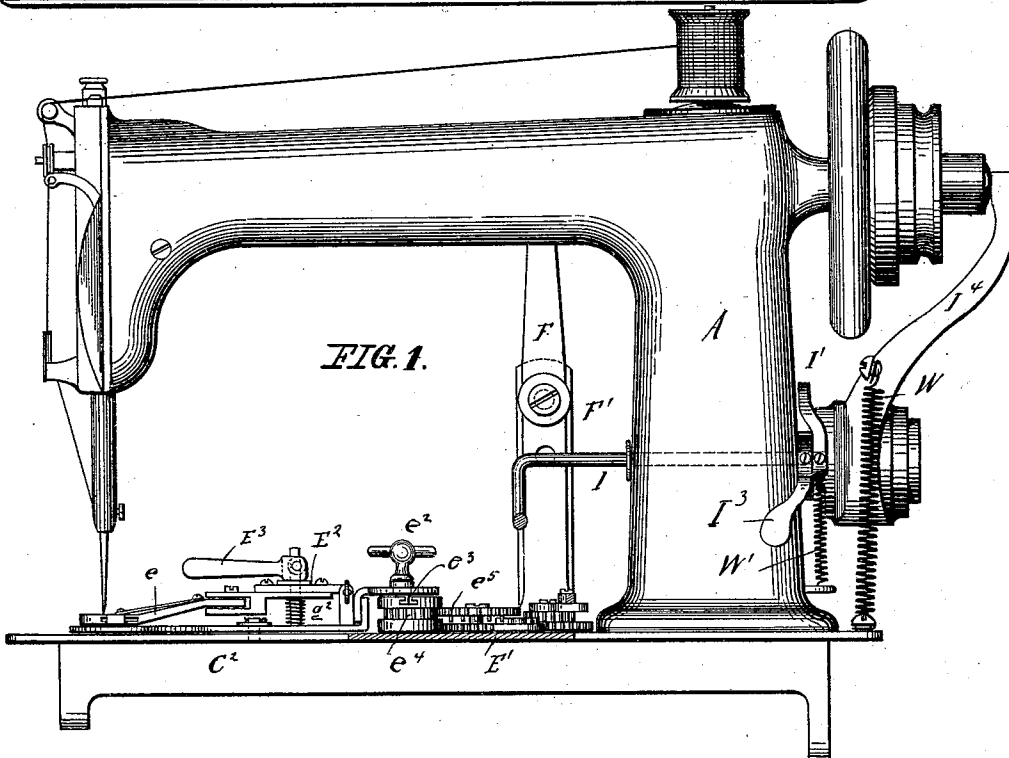

FIG. 1.



WITNESSES:
Marion Hall
Charles Bles

INVENTOR
P. Schoen
 BY *James P. ...*
 ATTORNEYS.

P. SCHOEN.
MACHINE FOR SEWING ON BUTTONS.

No. 487,972.

Patented Dec. 13, 1892.

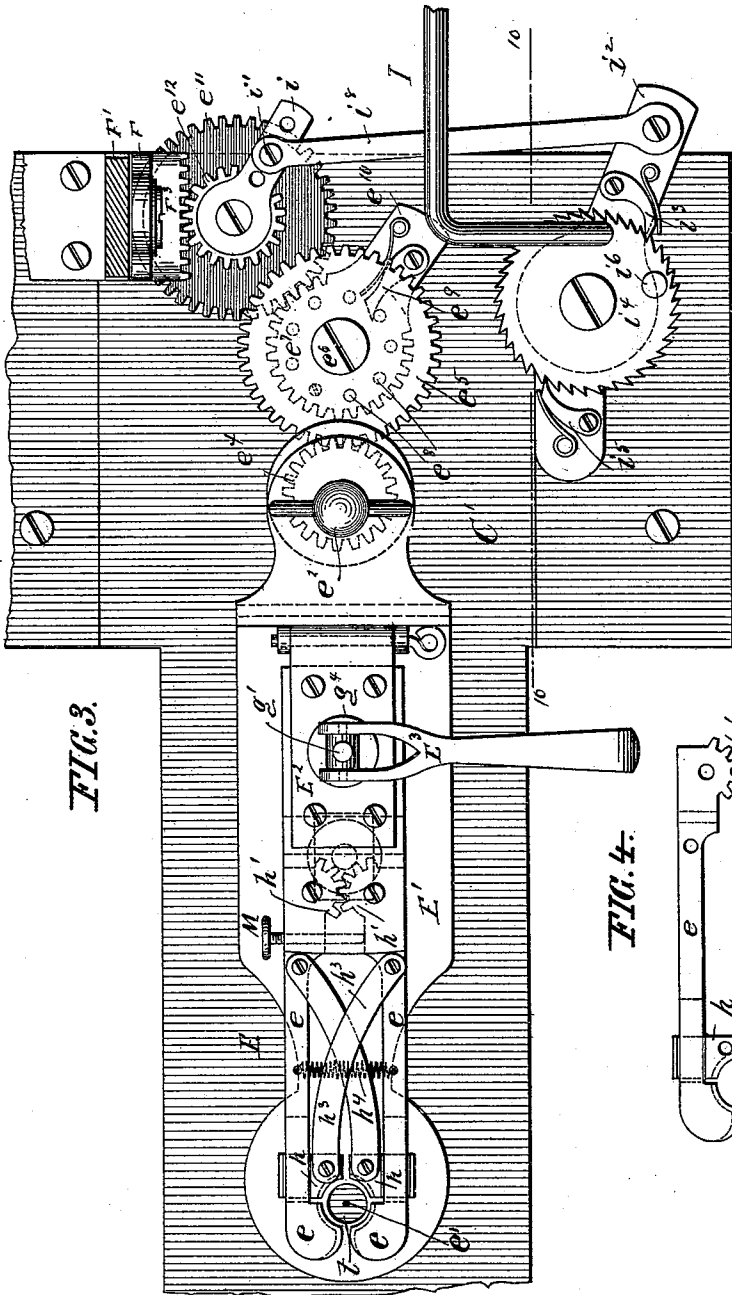

FIG. 3.

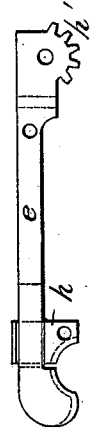

FIG. 4.

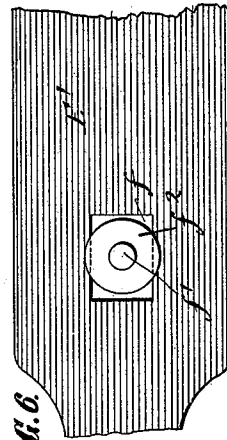

FIG. 6.

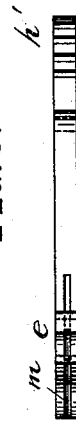

FIG. 5.

WITNESSES:
Manon Hall
Charles Bles

INVENTOR
P. Schoen
 BY *Lucas & Raegner*
 TORNEYS.

P. SCHOEN.
MACHINE FOR SEWING ON BUTTONS.

No. 487,972.

Patented Dec. 13, 1892.

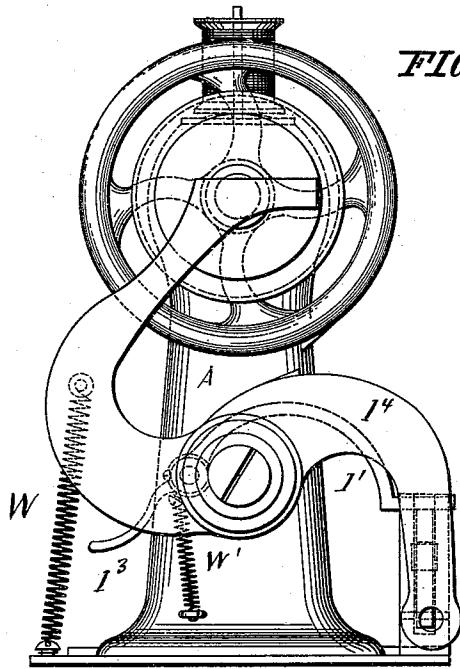

FIG. 7.

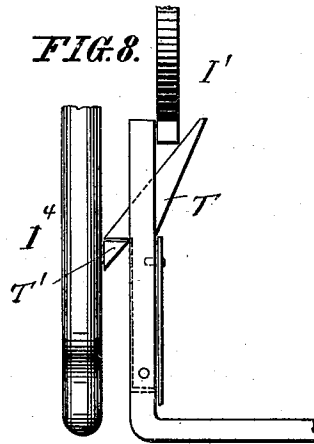

FIG. 8.

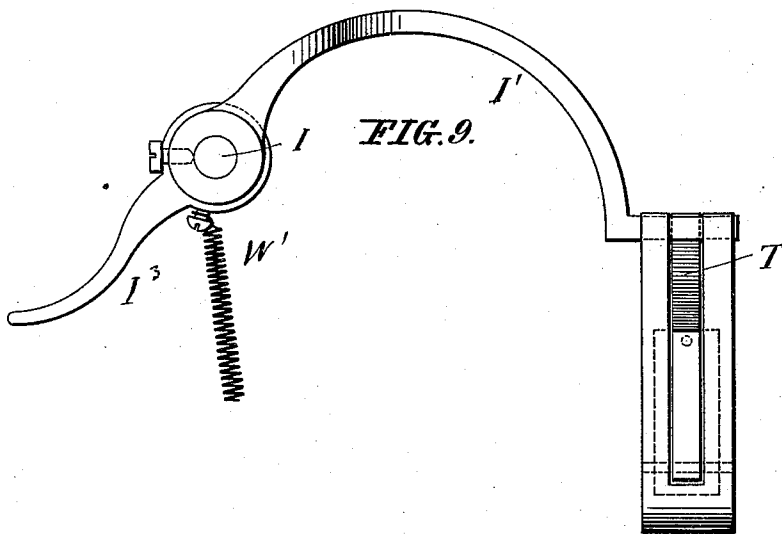

FIG. 9.

WITNESSES:
Tramon Hall
Charles Bels

INVENTOR
P. Schoen
 BY *Loebeck & Ragueur*
 ATTORNEYS.

P. SCHOEN.
MACHINE FOR SEWING ON BUTTONS.

No. 487,972.

Patented Dec. 13, 1892.

FIG. 12.

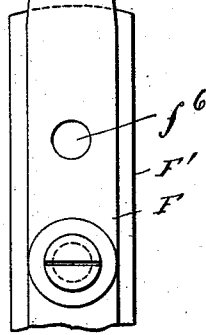
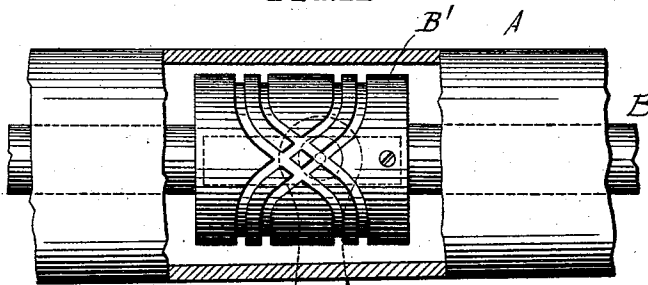
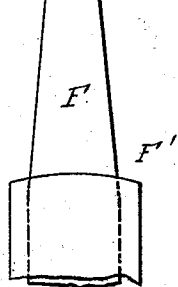
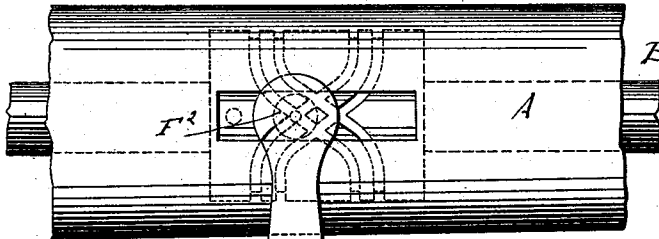

FIG. 13.



WITNESSES:

Marion Hall
Charles Bles

INVENTOR

P. Schoen

BY

Georg & Paegener
ATTORNEYS.

UNITED STATES PATENT OFFICE.

PAUL SCHOEN, OF HOBOKEN, NEW JERSEY.

MACHINE FOR SEWING ON BUTTONS.

SPECIFICATION forming part of Letters Patent No. 487,972, dated December 13, 1892.

Application filed August 6, 1891. Serial No. 401,869. (No model.)

To all whom it may concern:

Be it known that I, PAUL SCHOEN, a citizen of the United States, residing at Hoboken, in the county of Hudson and State of New Jersey, have invented certain new and useful Improvements in Button-Sewing Attachments for Sewing-Machines, of which the following is a specification.

This invention has reference to certain improvements in the button-sewing attachment for sewing-machines for which Letters Patent were granted to me, No. 464,042, dated December 1, 1891, said attachment being operated from the upper driving-shaft of the sewing-machine instead of being operated by mechanism actuated by the pressure-bar and needle-bar, in connection with a stop-motion by which the operation of the sewing-machine is automatically interrupted as soon as the required number of stitches for sewing on the button are produced.

The invention consists, substantially as hereinafter described and claimed, of a button-sewing attachment for sewing-machines, in which the oscillating and reciprocating plate on which the button-holder is supported is operated by means of transmitting gear-wheels and a segmental gear provided with a radial arm carrying a spring-pawl that engages ratchet-studs of a gear-wheel, said segmental gear being operated by a gear-wheel to which rotary reciprocating motion is imparted by a toothed section at the lower end of a fulcrumed lever, the upper end of which is engaged by a grooved cam on the upper driving-shaft of the sewing-machine, so that the required motion is imparted to the button-holder.

The invention consists, secondly, of the combination, substantially as hereinafter described and claimed, of the motion-transmitting mechanism of the button-sewing attachment, an oscillating lever carrying a spring-pawl, a ratchet-wheel operated by said spring-pawl, a pivot-link connecting the operating mechanism with the lever, a stop-motion, and a stop-lever provided with a bent arm operated by a stud on the ratchet-wheel, so as to release the stop-motion at the proper time.

The invention also consists in the construction and combination of parts and details, as

will be fully described hereinafter, and finally pointed out in the claims.

In the accompanying drawings, Figure 1 represents a side elevation of a sewing-machine provided with my improved button-sewing attachment. Fig. 2 is a plan view of the same, parts being broken away. Fig. 3 is an enlarged detail plan view of the attachment. Fig. 4 is a detail plan view of one of the button-holding jaws. Fig. 5 is a view of the inner side of the same. Fig. 6 is a detail view of the bottom plate of the attachment, showing the slot. Fig. 7 is a rear end view of the sewing-machine, showing the automatic stopping device. Fig. 8 is a detail side view of the spring-locking hook. Fig. 9 is a detail side view of the bent arm for actuating the stop-motion device. Fig. 10 is a detail side view of the attachment, parts being in section, on the line 10 10 of Fig. 3. Fig. 11 is a detail side view of the gearing for operating the bent arm that actuates the stop-motion device. Fig. 12 is a detail side view of the cam on the upper driving-shaft, parts of the supporting-arm being broken out; and Fig. 13 is a detail view of the upper end of the fulcrumed lever and its follower.

Similar letters of reference indicate corresponding parts.

By referring to the drawings, A represents the supporting-arm of a sewing-machine of any desired construction, and B the upper driving-shaft of the same.

C represents my improved button-holding attachment, which is applied to a main plate C', that is inserted into a corresponding recess of the base-plate C² of the sewing-machine, said plate C' being located below and parallel with the supporting-arm A of the sewing-machine. The button-holding attachment C is composed, mainly, of a button-holder E that is formed of an oscillating bottom plate E', which is fulcrumed to the plate C' and provided at the swinging end with a throat, within which is located the circular opening e' in the main plate C' for the passage of the needle-bar, and of two button-holding jaws e e, located above the opening e'. The opposite end of the bottom plate E' is connected by a clamping-screw e² to a dove-tailed guide-piece e³, that is transversely ad-

justable in the top part of a pinion e^4 , the shaft of which turns in bearings of the main plate C' . The rear end of the plate E' can thus be pivoted with more or less eccentricity to the pinion e^4 . The pinion e^4 meshes with an intermittently-rotating gear-wheel e^5 , that turns on a fixed shaft e^6 of the main plate C' . The bottom plate E' is provided at its middle part with an oblong slot f , through which a pin f' , fixed in the plate C' , passes, said pin serving as a fulcrum for the bottom plate E' , so that the same can be oscillated on the pin f' and simultaneously reciprocated. A washer f^2 surrounds the pin f' and rests upon the plate E' . The gear-wheel e^5 is provided on its underside with ratchet-studs e^8 , of which preferably nine are arranged; but more or less may be provided, according to the number of holes in the button, and some may be removed or omitted. The studs e^8 are arranged equidistant from each other and concentrically to the shaft of the gear-wheel e^5 , and are engaged by a spring-pawl e^9 , that is applied to the outer end of a radial arm e^{10} , attached to a segmental gear e^7 , that is mounted to oscillate on the fixed shaft e^6 of the gear-wheel e^5 . The segmental gear e^7 is provided with teeth at its circumference, which mesh with the gear-wheel e^{11} , that turns on a fixed shaft of the bottom plate C' . The gear-wheel e^{11} carries a pinion e^{12} , which meshes with the toothed lower end F^3 of a lever F , that is fulcrumed to an upright standard F' , which is attached to the main plate C' of the attachment. The upper end of the fulcrumed lever F is provided with a follower F^2 , that engages by projections a double groove in the circumference of a cam B' , which if attached to the upper driving-shaft B of the sewing-machine, said cam-groove imparting oscillating motion to the fulcrumed lever F , so that by the transmitting mechanism described oscillating and reciprocating motion is imparted to the bottom plate E' . The fulcrumed lever F is provided with several holes f^6 , so that the fulcrum can be changed to a higher or lower hole, and thereby the degree of oscillating motion of the lower toothed end be made larger or smaller, according to the degree of oscillating motion that is to be imparted to the button-holder. When the button is to be attached by stitches connecting the diagonal holes of the button, a comparatively-greater oscillating motion of the button-holder is required than when the button is attached by stitches connecting two adjoining holes of the button. The oscillating motion of the lower toothed end of the fulcrumed lever F transmits a corresponding degree of oscillating motion to the segmental gear e^{10} , which by its spring-pawl and the intermediate gear-wheel actuates the pinion e^4 , so as to impart a sliding and oscillating motion to the bottom plate E' and the entire button-holder E .

To a raised transverse portion of the bottom plate E' is hinged a plate E^2 , to which the

shanks of the button-holding jaws $e e$ are pivoted. Between the hinged plate E^2 and the bottom plate E' is interposed a helical spring g^2 , which is placed on a fixed post g' , said spring serving to lift the plate E^2 and the button-holding jaws e as soon as a cam-lever E^3 , that is pivoted by its forked end to the upper end of the post g' , is raised. The cam at the end of the lever E^3 presses the plate E^2 and the button-holding jaws e in downward direction, so that the latter are held firmly in contact with the bottom plate E' . The post g' passes through a hole of the hinged plate E^2 , while a washer g^4 is interposed between said plate and the cam of the lever E^3 . The button-holding jaws $e e$ are so arranged that they automatically adjust themselves to hold different sizes of buttons. For this purpose they are provided with grooves m in their inner faces at the free ends, which grooves hold the button at opposite points, while the same is held at two additional points of its circumference by the grooved parts of slide-pieces h , which are guided on the shanks of the jaws $e e$, so as to slide forward or backward on the same, according as the jaws are opened more or less, as required by different sizes of buttons. The rear ends of the shanks of the jaws e are pivoted to the hinged plate E^2 and are provided with toothed segments h' , that mesh with each other, which segments produce the joint motion of the jaws when either one of them is taken hold of for inserting or removing a button. The jaws are adjusted nearer to or farther away from each other by means of a suitable screw M , that projects from one side of one of the jaws e , as shown clearly in Fig. 3. The shanks of the jaws $e e$ are further connected by means of independently-pivoted cross-links h^3 with the slide-pieces h , by which said slide-pieces are moved inwardly or outwardly on the shanks of the jaws $e e$, so as to adjust themselves to the size of the button inserted between the jaws e . The button-holding jaws e are further connected by a helical spring h^4 , that extends transversely from one shank to the other and is applied to eyes of the same, so that the jaws are pressed tightly on the button and hold the same firmly in position for the passage of the needle through the holes of the same. As the button-holder and its adjacent mechanism are fully claimed in the application before referred to, no claim is made to these parts in this application.

For the purpose of automatically stopping the sewing-machine when the button is sewed on by the required number of stitches a stop-motion that is arranged in connection with the driving-pulley of the driving-shaft B is connected with the motion-transmitting mechanism of the button-holding attachment by means of a pawl-and-ratchet device in such a manner that the stop-motion is automatically thrown into action and the machine stopped as soon as the button is sewed to the garment by the number of stitches for which the at-

tachment is adjusted. For this purpose the pinion e^{12} of the gear-wheel e^{11} is provided with a crank-arm i , having a number of holes, to one of which a pivot-pin i' of a link i^3 is applied, that connects said crank-arm i with an oscillating lever i^2 . The lever i^2 is loosely applied to a fixed shaft of the main plate C' and provided with a spring-pawl i^3 , which engages the teeth of a ratchet-wheel i^4 , which turns loosely on said fixed shaft and is prevented by a check-pawl i^5 from turning in opposite direction. According to the distance to which the pivot-pin i' is adjusted on the apertured crank-arm i a larger or smaller stroke of the lever i^2 is produced, and consequently a smaller or larger degree of rotating motion imparted to the ratchet-wheel i^4 . If, for instance, the button is to be sewed on by twelve stitches, the pivot-link is adjusted to the corresponding hole of the crank-arm i , so that during one revolution of the ratchet-wheel i^4 twelve stitches are formed. A stud i^6 on the ratchet-wheel i^4 engages after the full rotation of the ratchet-wheel is completed the lower end of a downwardly-bent arm I , the horizontal portion of which turns in bearings on the main arm of the sewing-machine and forms at the same time the pivot of the stop-lever I' , secured thereto, and by which the stop-motion is thrown into action. Any suitable stop-motion may be employed, that shown in the drawings being composed of an S-shaped arm I^4 , that is fulcrumed near its center to the supporting main arm of the sewing-machine, the upper arm engaging the driving-pulley and placing it in frictional connection with the upper driving-shaft of the sewing-machine, while the lower arm is locked in position by means of a suitably-pivoted spring-actuated hook T , which engages a tooth T' on the lower end of the S-shaped arm I^4 until said spring-hook is released by the pressure of the rear end of the stop-lever I' , whether the same is operated by the stud on the ratchet-wheel or by an independent finger-piece I^3 , that projects in forward direction from the stop-lever I' . A treadle is to be connected to the lower end of the fulcrumed arm I^4 of the stop-motion to set the stop-motion into frictional contact with the driving-shaft and establish the locking connection with the spring-hook. A helical spring W , connected with the stop-motion arm I^4 , tends to draw the same downward to throw the machine out of gear. A helical spring W' is connected with the stop-lever I' and serves to hold the same disengaged from the hook T . As soon as the stud i^6 on the ratchet-wheel i^4 raises the bent arm I , forming the pivot of the stop-lever I' , the locking connection between the spring-hook T and the S-shaped arm I^4 of the stop-motion is interrupted, the arm is pulled down by its spring W , and thereby the frictional connection between the driving-pulley and driving-shaft interrupted, so that the sewing-machine is stopped.

I do not claim the stop-motion herein described, as the same is well known; but I claim the automatic connection between the stop-motion and my improved button-sewing attachment, so that the stop-motion is automatically actuated as soon as the required number of stitches by which the button is to be sewed to the fabric is produced. Any other stop-motion may be used, provided that the same is automatically operated by the button-sewing mechanism.

The operation of my improved button-sewing attachment is as follows: A button of the proper size is inserted into the button-holding jaws $e e$ by spreading them apart and is engaged by the grooves at the inner faces of the jaws and the grooves at the inner faces of the slide-pieces h . The garment or other object to which the button is to be attached is then introduced between the bottom plate E' and the jaws e and the latter pressed down by the cam-lever E^3 . The sewing-machine is then started in the usual manner. By the reciprocating motion of the needle, in combination with the oscillating and reciprocating action imparted to the button-holder by the transmitting mechanism operated by the cam B' on the upper driving-shaft, the button is sewed on until the required number of stitches are produced, at which time the ratchet-wheel i^4 has completed its revolution and actuates the stop-motion, so that the sewing-machine is stopped. After the button is sewed on the garment it is removed from the button-holder by simply sliding it out of the same, the jaws giving sufficiently by the spring connection to permit the ready withdrawal of the button. A new button is then inserted into the holder and the sewing operation performed in the manner before described. By my improved button-sewing attachment the buttons can be sewed on quickly and neatly to all kinds of garments, the attachment being readily removed from the machine, including the oscillating transmitting-lever F and the pawl and ratchet-wheel connection by which the stop-motion is actuated, the attachment being screwed to the table of the sewing-machine when it is required to use the machine for sewing buttons to garments.

Having thus described my invention, I claim as new and desire to secure by Letters Patent—

1. The combination, with the driving-shaft of a sewing-machine, of an oscillating and reciprocating plate, a button-holder supported thereon, a fulcrumed lever having teeth at its lower end and oscillated by a cam on the driving-shaft of the machine, a pinion meshing with the teeth of said oscillating lever, and transmitting mechanism between said pinion and the supporting-plate of the button-holder, whereby oscillating and reciprocating motion is imparted to said button-holder, substantially as set forth.

2. The combination, with the driving-shaft of a sewing-machine, of a main plate, an oscil-

lating and reciprocating plate, a button-holder supported on said oscillating plate, a standard fixed to said main plate, a vertical lever fulcrumed to said standard, a cam on said driving-shaft for actuating said lever, and motion-transmitting mechanism between the lower end of the lever and the supporting-plate of the button-holder, whereby oscillating and reciprocating motion is imparted to said button-holder, substantially as set forth.

3. The combination, with the driving-shaft of a sewing-machine, said shaft having a grooved cam, of an oscillating and reciprocating plate, a button-holder supported thereon, a pinion to which the rear end of said oscillating plate is pivoted eccentrically, a gear-wheel meshing with said pinion and provided with ratchet-studs, a segmental gear, a radial arm attached thereto carrying a spring-pawl for engaging said studs, a second gear-wheel meshing with the segmental gear, a pinion keyed to said gear-wheel, and a fulcrumed lever operated by the cam on the driving-shaft and provided with a toothed section at its lower end that meshes with the pinion on the last gear-wheel, substantially as set forth.

4. The combination, with the driving-shaft of a sewing-machine, of a cam on the same, an oscillating and reciprocating plate, a button-holder supported on said plate, a motion-transmitting mechanism connected with the rear end of the oscillating plate, a fulcrumed lever provided with teeth at its lower end and actuated by the cam on the driving-shaft, a pinion meshing with said teeth and adapted to actuate the transmitting mechanism by which the button-holder is operated, a stop-motion for the driving-shaft of the sewing-machine, a stop-lever, a pawl-and-ratchet mechanism, and a bar connecting said pawl-and-ratchet mechanism with said pinion, said pawl-and-ratchet mechanism being operated by the motion-transmitting mechanism of the button-holder and adapted to actuate the

stop-lever and stop-motion and throw it out of clutch with the driving-shaft when the required number of stitches have been made, substantially as set forth.

5. The combination, with the driving-shaft of a sewing-machine, of a cam on said driving-shaft, an oscillating and reciprocating plate, a button-holder supported on said plate, an oscillating lever supported on an upright standard, said lever being actuated by the cam on the driving-shaft, motion-transmitting mechanism interposed between the lower end of the oscillating lever and the oscillating plate of the button-holder, a pawl-and-ratchet mechanism, a pivot-link connecting the motion-transmitting mechanism of the button-holder with said pawl-and-ratchet mechanism, a stud on said ratchet-wheel, a stop-motion for the driving-shaft, and a stop-lever provided with a bent arm that is adapted to be engaged by the stud on the ratchet-wheel, so as to release the stop-motion at the proper time, substantially as set forth.

6. The combination, with the driving-shaft of a sewing-machine, of a reciprocating and oscillating plate, a button-holder thereon, a pinion to which the rear end of said plate is pivoted eccentrically, a fixed shaft, a cog-wheel on said shaft engaging said pinion and having fixed pins and removable pins, a segmental gear on said fixed shaft provided with a radial arm, a pawl on said arm engaging the pins on said cog-wheel, a gear meshing with said segmental gear, and means for operating said gear from the driving-shaft, substantially as described.

In testimony that I claim the foregoing as my invention I have signed my name in presence of two subscribing witnesses.

PAUL SCHOEN.

Witnesses:
OSCAR F. GUNZ,
A. M. BAKER.