

(19)



(11)

EP 3 745 072 A1

(12)

EUROPEAN PATENT APPLICATION

(43) Date of publication:
02.12.2020 Bulletin 2020/49

(51) Int Cl.:
F28D 9/00 (2006.01) F28F 1/00 (2006.01)

(21) Application number: **19177262.3**

(22) Date of filing: **29.05.2019**

(84) Designated Contracting States:
AL AT BE BG CH CY CZ DE DK EE ES FI FR GB GR HR HU IE IS IT LI LT LU LV MC MK MT NL NO PL PT RO RS SE SI SK SM TR
 Designated Extension States:
BA ME
 Designated Validation States:
KH MA MD TN

(72) Inventors:
 • **JENSEN, Jan Ostenfeldt**
8700 Horsens (DK)
 • **BENDSEN, Jari**
8700 Horsens (DK)
 • **BACHMANN, Jonas**
8700 Horsens (DK)

(71) Applicant: **Nissens Cooling Solutions A/S**
8700 Horsens (DK)

(74) Representative: **Dragsted Partners A/S**
Rådhuspladsen 16
1550 Copenhagen V (DK)

(54) **A DUAL MEDIA SAFETY HEAT EXCHANGER**

(57) The present invention relates to a dual media safety heat exchanger comprising a first medium chamber configured to allow a first medium flow through the first medium chamber, a second medium chamber configured to allow a second medium flow through the second medium chamber and an intermediate chamber arranged between the first medium chamber and the second medium chamber and being configured to separate the first medium chamber from the second medium chamber so that the first medium is prevented from being mixed with the second medium or vice versa in the circumstance of a leak within the safety heat exchanger.

The first medium chamber, the second medium chamber and the intermediate chamber are arranged in a stacked manner, the first medium chamber having a first inlet and a first outlet, the second medium chamber having a second inlet and a second outlet, the first medium chamber, the second medium chamber and the intermediate chamber being defined by a plurality of chamber plates having a configuration, wherein the configuration of each chamber plate is substantially identical irrespective of which chamber it is part of. The invention also relates to a method for preparing a dual media safety heat exchanger.

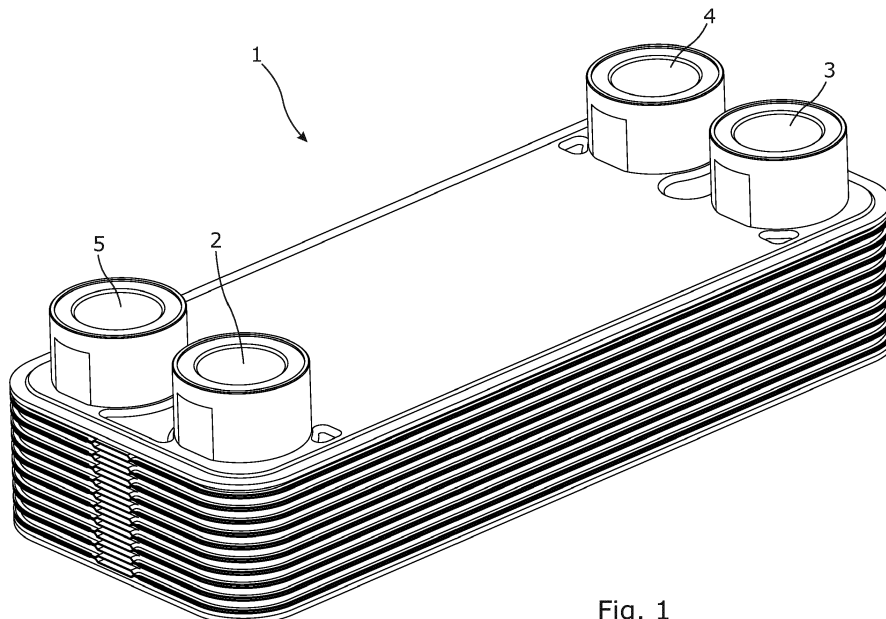

Fig. 1

EP 3 745 072 A1

Description

[0001] The present invention relates to a dual media safety heat exchanger comprising

- a first medium chamber configured to allow a first medium flow through the first medium chamber,
- a second medium chamber configured to allow a second medium flow through the second medium chamber, and
- an intermediate chamber arranged between the first medium chamber and the second medium chamber and being configured to separate the first medium chamber from the second medium chamber so that the first medium is prevented from being mixed with the second medium or vice versa in the circumstance of a leak within the safety heat exchanger,
- the first medium chamber, the second medium chamber and the intermediate chamber being arranged in a stacked manner,
- the first medium chamber having a first inlet and a first outlet,
- the second medium chamber having a second inlet and a second outlet,
- the first medium chamber, the second medium chamber and the intermediate chamber being defined by a plurality of chamber plates having a configuration.

[0002] Dual media safety heat exchangers are known in the prior art. They are used to separate a working fluid to be cooled from a heat transfer medium in a heat exchanger. When special working fluid is being used which may not be mixed with a heat transfer medium, the heat exchanger has safety chambers incorporated between other medium chambers which act as a buffer zone between the medium chambers.

[0003] However, due to the special construction of the known heat exchangers they may be difficult to manufacture which may often jeopardise leakage tightness of the chambers which again may result in unintended leak of the working fluid and/or heat transfer medium, and hence a potential mix of the fluids.

[0004] Accordingly, there is a need for providing an enhanced dual media safety heat exchanger.

[0005] It is an object of the present invention to wholly or partly overcome the above disadvantages and drawbacks of the prior art. More specifically, it is an object to provide an improved dual media safety heat exchanger which has enhanced fluid tightness and at the same time is easy to manufacture without jeopardising the heat transfer properties between a first medium and a second medium.

[0006] The above objects, together with numerous other objects, advantages and features, which will become evident from the below description, are accomplished by a solution in accordance with the present invention by a dual media safety heat exchanger comprising

- a first medium chamber configured to allow a first medium flow through the first medium chamber,
- a second medium chamber configured to allow a second medium flow through the second medium chamber, and
- an intermediate chamber arranged between the first medium chamber and the second medium chamber and being configured to separate the first medium chamber from the second medium chamber so that the first medium is prevented from being mixed with the second medium or vice versa in the circumstance of a leak within the safety heat exchanger,
- the first medium chamber, the second medium chamber and the intermediate chamber being arranged in a stacked manner,
- the first medium chamber having a first inlet and a first outlet,
- the second medium chamber having a second inlet and a second outlet,
- the first medium chamber, the second medium chamber and the intermediate chamber being defined by a plurality of chamber plates having a configuration, wherein the configuration of each chamber plate is substantially identical irrespective of which chamber it is part of.

[0007] According to the inventive idea, all chamber plates are substantially identical in configuration.

[0008] Furthermore, the heat exchanger may comprise a plurality of first medium chambers, a plurality of second medium chambers and a plurality of intermediate chambers, all being arranged in a stacked manner.

[0009] Moreover, the chamber plates may be made from a blank material.

[0010] The material may be metal, preferably aluminium or any alloys thereof.

[0011] Also, the first inlet and the first outlet may be extending through the stacked chamber plates and provide a first inlet channel and a first outlet channel being fluidly connected with the plurality of first medium chambers, the second inlet and the second outlet may be extending through the stacked chamber plates and provide a second inlet channel and a second outlet channel being fluidly connected with the plurality of second medium chambers.

[0012] In addition, the first inlet channel may be configured to distribute the first medium to all the first medium chambers, and the second inlet channel is configured to distribute the second medium to all the second medium chambers.

[0013] Furthermore, the first medium chambers may be arranged in parallel in relation to the first inlet channel, and the second medium chambers are arranged in parallel in relation to the second inlet channel.

[0014] Also, one or more turbulators may be arranged in the first medium chamber, the second medium chamber and/or the intermediate chamber.

[0015] Moreover, the intermediate chamber may com-

prise a chamber outlet wherefrom the first medium or the second medium eventually leaked into the intermediate chamber may be drained.

[0016] Further, the embossments may enhance the heat transfer between the chambers and provide stability to the heat exchanger structure.

[0017] Additionally, embossments may be provided in the chamber plates, the embossments being herringbone-shaped.

[0018] The herringbone-shaped embossments may be provided in the intermediate chamber when stacked.

[0019] Also, each chamber plate may be substantially square-formed provided with four apertures at each corner, the apertures are configured to defining the first inlet channel, the first outlet channel, the second inlet channel and the second outlet channel, respectively.

[0020] Moreover, the chamber plate may have a centre axis, two of the apertures are arranged on a first side of the centre axis and the other two apertures are arranged on a second side of the centre axis, the second side being opposite side of the first side in relation to the centre axis.

[0021] The two apertures may be arranged on the first side being the first apertures and have a first diameter, the two apertures arranged on the second side being the second apertures have a second diameter, the first diameter being larger than the second diameter.

[0022] Furthermore, the chamber plate may have a first face and a second face, first rim sections are provided around the first apertures, the first rim sections are projecting from the first face having a first distance, second rim sections are provided around the second apertures, the second rim sections are extending from the second face having a second distance.

[0023] Also, the second distance may be larger than the first distance, preferably the second distance is at least twice the distance of the first distance.

[0024] A first end plate may be arranged on a first end of the stacked chamber plates, and a second end plate is arranged on a second end of the stacked chamber plates.

[0025] The first end plate and the second end plate may be part of the stacked plates.

[0026] Furthermore, the chamber plates of the heat exchanger may be soldered together.

[0027] The first medium may be oil or water.

[0028] The second medium may be oil or water.

[0029] The invention also relates to a method for preparing a dual media safety heat exchanger according to any of the preceding claims, comprising

- providing a plurality of chamber plates being substantially identical,
- providing a first chamber plate,
- providing a second chamber plate,
- stacking the second chamber plate on top of the first chamber plate by arranging the second face of the first chamber plate opposite to the second face of the second

[0030] chamber plate while aligning the first apertures of the first chamber plate with the second apertures of the second chamber plate,

- 5 - providing a third chamber plate,
- stacking the third chamber plate on top of the second chamber plate by arranging the first face of the third chamber plate opposite to the first face of the second chamber plate while aligning the second apertures of the second chamber plate with the second apertures of the third chamber plate,
- 10 - providing a fourth chamber plate,
- stacking the fourth chamber plate on top of the third chamber plate by arranging the second face of the third chamber plate opposite to the second face of the fourth chamber plate while aligning the first apertures of the third chamber plate with the second apertures of the fourth chamber plate,
- 15 - continuing stacking chamber plates in the same manner until a predetermined size of the heat exchanger is obtained, and
- connecting the chamber plates in a fluid tight manner providing the first medium chambers, the second medium chamber and the intermediate chambers.

[0031] The connecting of the chamber plates may be performed by soldering.

[0032] In addition, a first end plate and a second end plate may be stacked with the chamber plates.

30 **[0033]** The invention also relates to a use of a dual media safety heat exchanger as described above for applications wherein the first medium and the second medium may not be mixed.

35 **[0034]** The invention and its many advantages will be described in more detail below with reference to the accompanying schematic drawings, which for the purpose of illustration show some non-limiting embodiments and in which

40 Fig. 1 shows a dual media safety heat exchanger according to the invention,

Fig. 2 shows the dual media safety heat exchanger of Fig. 1 in a partly exploded view,

45 Fig. 3 shows a cross-sectional view of the dual media safety heat exchanger of Fig. 1,

50 Fig. 4 shows another cross-sectional view of the dual media safety heat exchanger of Fig. 1,

Fig. 5 shows the cross-sectional view of Fig. 4 with the first medium and the second medium,

55 Fig. 6 shows a partly exploded view of the dual media safety heat exchanger of Fig. 1 indicating the flow of the first medium and the second medium,

Fig. 7 shows another embodiment of the dual media safety heat exchanger, and

Figs. 8a and 8b show an embodiment of a chamber plate and a cross-sectional view of two chamber plates being connected.

[0035] All the figures are highly schematic and not necessarily to scale, and they show only those parts which are necessary in order to elucidate the invention, other parts being omitted or merely suggested.

[0036] Fig. 1 shows a dual media safety heat exchanger 1 in a perspective view. The dual media safety heat exchanger 1 is configured to allow a first medium and a second medium flow through the heat exchanger 1.

[0037] The dual media safety heat exchanger 1 comprises a first inlet 2 and a first outlet 3. The first inlet 2 and the first outlet 3 are fluidly connected with a first medium chamber (not shown) or a plurality of first medium chambers for allowing a first medium flowing through the heat exchanger 1. The dual media safety heat exchanger 1 also comprises a second inlet 4 and a second outlet 5. The second inlet 4 and the second outlet 5 are fluidly connected with a second medium chamber (not shown) or a plurality of second medium chambers for allowing a second medium flowing through the heat exchanger 1.

[0038] The dual media safety heat exchanger 1 according to the present invention comprises a plurality of first medium chambers, a plurality of second medium chambers and a plurality of intermediate chambers being arranged between adjacent first medium chamber and second medium chamber, the intermediate chamber being configured to separate the first medium chamber from the second medium chamber so that the first medium is prevented from being mixed with the second medium or vice versa in the circumstance of a leak within the safety heat exchanger 1. The plurality of first medium chambers, the plurality of second medium chambers and the plurality of intermediate chambers are advantageously stacked on each other. The construction of the dual media safety heat exchanger 1 will be described further below.

[0039] In Fig. 2 the dual media safety heat exchanger 1 is shown in a partly exploded view, the dual media safety heat exchanger 1 comprising a first medium chamber 6 configured to allow a first medium flow through the first medium chamber 6, a second medium chamber 7 configured to allow a second medium flow through the second medium chamber 7 and an intermediate chamber 8 arranged between the first medium chamber 6 and the second medium chamber 7. As mentioned above, the intermediate chamber 8 is configured to separate the first medium chamber 6 from the second medium chamber 7 so that the first medium is prevented from being mixed with the second medium or vice versa in the circumstance of a leak within the safety heat exchanger 1.

[0040] As shown in Fig. 2, the first medium chamber 6, the second medium chamber 7 and the intermediate

chamber 8 are arranged in a stacked manner. The heat exchanger 1 may comprise a plurality of first medium chambers 6, a plurality of second medium chambers 7 and a plurality of intermediate chambers 8 and thereby be configured to the specific heat transfer demand and application.

[0041] The first medium chamber 6, the second medium chamber 7 and the intermediate chamber 8 are defined by a plurality of chamber plates 9 having a configuration. The configuration of each chamber plate 9 is substantially identical irrespective of which chamber 6, 7, 8 it is part of.

[0042] The term "configuration" means the design and layout of the chamber plates.

[0043] The chamber plates 9 may be made from a blank material. The material is metal, preferably aluminium or any alloys thereof.

[0044] In the present embodiment, each chamber plate 9 is substantially square-formed provided with four apertures, one at each corner. The apertures are configured to defining the first inlet channel, the first outlet channel, the second inlet channel and the second outlet channel, respectively.

[0045] The chamber plate 9 has a centre axis A, two of the apertures are arranged on a first side 10 of the centre axis, and the other two apertures are arranged on a second side 11 of the centre axis, the second side 11 being opposite side of the first side 10 in relation to the centre axis A. The two apertures arranged on the first side 10 being the first apertures 12 have a first diameter D1, the two apertures arranged on the second side 11 being the second apertures 13 have a second diameter D2, the first diameter D1 being larger than the second diameter D2.

[0046] Furthermore, the chamber plate 9 has a first face 14 and a second face 15, first rim sections 16 are provided around the first apertures 12, the first rim sections 16 project from the first face 14 having a first height h1. Second rim sections 17 are provided around the second apertures 13, the second rim sections 17 project from the second face 15 having a second height h2. The second distance is larger than the first distance, preferably the second distance is at least twice the distance of the first distance. Hereby is obtained that when the chamber plates 9 are stacked in correct manner, the second rim sections 17 may project up in the first apertures 12.

[0047] How the plurality of chamber plates 9 are stacked for providing the first medium chambers, the second medium chambers and the intermediate chambers will be described further below.

[0048] The heat exchanger 1 also comprises a first end plate 18 being arranged on a first end 20 of the stacked chamber plates 9 and a second end plate 19 being arranged on a second end 21 of the stacked chamber plates 9, whereby the first end plate 18 and the second end plate 19 are part of the stacked plates defining the heat exchanger 1. In the present embodiment, the first end plate 18 and the second end plate 19 being different of

the chamber plates 9, however, is made in the same size as the chamber plates. The end plates 18, 19 may also be part of defining either a first medium chamber, a second medium chamber or an intermediate chamber. In the present embodiment, the first end plate 18 comprises the first inlet 2, the first outlet 3, the second inlet 4 and the second outlet 5. The second end plate 19 has in this embodiment four plug parts 22 being configured close off the first inlet channel, the first outlet channel, the second inlet channel and the second outlet channel.

[0049] Each chamber plate 9 also has an embossment section 23 which projects from the first face 14 and is extending around near the circumference of the chamber plate 9.

[0050] Each chamber plate 9 also has an edge section 24 which projects from the second face 15 and is extending around the circumference of the chamber plate 9. The edge section 24 is arranged closer to the circumference than the embossment section 23.

[0051] The embossment section 23 and the edge section 24 are configured to provide a space between adjacent chamber plates 9 when they are being stacked whereby the chambers are created between the chamber plates 9.

[0052] In the present embodiment, the edge section 24 comprises two depressions 25. The depressions 25 provide two chamber outlets 26 of the intermediate chamber 8 when the chamber plates 9 are stacked. The chamber outlets 26 are configured to drain the first medium or the second medium which has eventually leaked into the intermediate chamber from the adjacent first medium chamber and/or the adjacent second medium chamber.

[0053] Figs. 3 and 4 show the heat exchanger 1 in two different cross-sectional views. The chamber plates 9 are stacked for providing the first medium chambers, the second medium chambers and the intermediate chambers.

[0054] Fig. 3 shows a cross-sectional view taken along the longitudinal extension of the heat exchanger 1. As mentioned above, the first medium chamber has a first inlet 2 and a first outlet 3. In the present embodiment, the first inlet 2 and the first outlet 3 are extending through the stacked chamber plates 9 and provide a first inlet channel 27 and a first outlet channel 28 being fluidly connected with the plurality of first medium chambers.

[0055] In the same manner, the second medium chamber has a second inlet and a second outlet. In the present embodiment, the second inlet and the second outlet are extending through the stacked chamber plates 9 and provide a second inlet channel (not shown) and a second outlet channel being fluidly connected with the plurality of second medium chambers.

[0056] In Fig. 4, another cross-sectional view is shown. The first inlet 2 and the first inlet channel 27 and the second outlet 5 and the second outlet channel 29 are shown.

[0057] Fig. 4 also shows how the identical chamber plates 9 are stacked for providing the heat exchanger 1 and the first end plate 18 and the second end plate 19.

As shown, the embossment sections 23 of two adjacent chamber plates 9 are abutting, and the edge sections 24 of two adjacent chamber plates 9 are also abutting for providing the chambers between them.

[0058] In addition, the second rim section 17 is configured to abut another second rim section of a chamber plate 9 being in a position where two other chamber plates 9 are arranged between them. Hence, the abutment of two second rim sections provide the channel through the chamber plates 9.

[0059] Preferably, all the chamber plates 9 and end plates 18, 19 are soldered together in leak-tight manner. In this cross-sectional view, the heights of the projecting first and second rim sections 16, 17 are shown (see also Fig. 2).

[0060] Fig. 5 shows the same cross-sectional view as in Fig. 4 with a first medium 30 and a second medium 31 flowing in the heat exchanger 1. The first inlet channel 27 is configured to distribute the first medium 30 to all the first medium chambers 6. In the same manner, the second inlet channel (not shown) is configured to distribute the second medium to all the second medium chambers. In Fig. 5, the second outlet channel 29 is shown and the second medium chamber 7. Between the first medium chambers 6 and the second medium chambers 7, the intermediate chambers 8 are arranged providing safety to the heat exchanger 1.

[0061] As shown in Fig. 5, the first medium chambers 6 are arranged in parallel in relation to the first inlet channel 27. In the same manner, the second medium chambers (not shown) are arranged in parallel in relation to the second inlet channel.

[0062] Fig. 6 shows in a partly exploded view the flow of the first medium 30 and the second medium 31 through the heat exchanger 1. The first medium 30 enters through the first inlet 2 and therefrom into the first inlet channel and hereinafter into the first medium chambers 6 wherefrom it is led out of the heat exchanger 1 via the first outlet channel to the first outlet 3. In the same manner, the second medium 31 enters through the second inlet 4 and therefrom into the second inlet channel and hereinafter into the second medium chambers 7 wherefrom it is led out of the heat exchanger 1 via the second outlet channel to the second outlet 5.

[0063] For providing enhanced heat transfer between the first medium and the second medium, the two media flow counter current through the heat exchanger 1.

[0064] For enhancing the heat transfer, one or more turbulators (not shown) may be arranged in the first medium chamber, the second medium chamber and/or the intermediate chamber.

[0065] Fig. 7 shows another embodiment of the heat exchanger 1. The construction of the heat exchanger 1 is substantially identical with the one described above. In the present embodiment the chamber plates 9 are provided with a plurality of embossments 32. Hence when the chamber plates are stacked in the predetermined process, the embossments 32 are configured to abut in

the intermediate chamber 8 whereby the heat transfer through the intermediate chamber 8 is enhanced. The embossments 32 furthermore provide structure to the heat exchanger 1.

[0066] In Fig. 8a, the chamber plate 9 is shown in a top view. The plurality of embossment 32 are provided in the chamber plate 9. Still, the chamber plate has the same configuration as described above in that inter alia provided with the first inlet 2, the first outlet 3, the second inlet 4 and the second outlet 5. In this view, the first rim section 16 is seen surrounding the second rim section 17, the first and second rim sections being separated by a safety passage 40.

[0067] In Fig. 8b, a cross-sectional view taken along the line VIII B of Fig. 8a is shown. Two chamber plates 9 are stacked in the predetermined manner having the plurality of embossments 32. In the enlarged view, the embossments 32 of two adjacent chamber plates 9 are abutting so that the intermediate chamber 8 is provided with enhanced heat transfer and structure. Furthermore, an enlarged view of the details of the chamber plates 9 near the second inlet 4 and the second outlet 5 is shown. It is shown that the second rim section 17 having a height h_1 projects to the same level as the first rim section 16 having a lower height h_2 . Around the second rim section 17, a safety passage 40 is present. Hence, when a further set of chamber plates 9 are placed on top of a first set of chamber plates 9, the connection between first rim sections 16 and the connection of the second rim sections 17 are separated by the safety passage 40. Therefore, if a leak should occur in either of the connections, the leak will flow into the safety passage 40 and out.

[0068] The embossments 32 are in the present embodiment shown as being herring-bone shaped. Other configurations of the embossments may be applied.

[0069] The first medium may be the medium which has to be treated, for instance cooled. The second medium may then be the heat transfer medium configured to cool the first medium.

[0070] The dual media safety heat exchanger may in an embodiment be made as follows:

- providing a plurality of chamber plates being substantially identical,
- providing a first chamber plate,
- providing a second chamber plate,
- stacking the second chamber plate on top of the first chamber plate by arranging the second face of the first chamber plate opposite to the second face of the second chamber plate while aligning the first apertures of the first chamber plate with the second apertures of the second chamber plate,
- providing a third chamber plate,
- stacking the third chamber plate on top of the second chamber plate by arranging the first face of the third chamber plate opposite to the first face of the second chamber plate while aligning the second apertures of the second chamber plate with the second aper-

tures of the third chamber plate,

- providing a fourth chamber plate,
- stacking the fourth chamber plate on top of the third chamber plate by arranging the second face of the third chamber plate opposite to the second face of the fourth chamber plate while aligning the first apertures of the third chamber plate with the second apertures of the fourth chamber plate,
- continuing stacking chamber plates in the same manner until a predetermined size of the heat exchanger is obtained, and
- connecting the chamber plates in a fluid tight manner providing the first medium chambers, the second medium chamber and the intermediate chambers.

[0071] Advantageously, the connecting of the chamber plates may be performed by means of soldering.

[0072] Although the invention has been described in the above in connection with preferred embodiments of the invention, it will be evident for a person skilled in the art that several modifications are conceivable without departing from the invention as defined by the following claims.

Claims

1. A dual media safety heat exchanger comprising

- a first medium chamber configured to allow a first medium flow through the first medium chamber,
- a second medium chamber configured to allow a second medium flow through the second medium chamber, and
- an intermediate chamber arranged between the first medium chamber and the second medium chamber and being configured to separate the first medium chamber from the second medium chamber so that the first medium is prevented from being mixed with second medium or vice versa in the circumstance of a leak within the safety heat exchanger,
- the first medium chamber, the second medium chamber and the intermediate chamber being arranged in a stacked manner,
- the first medium chamber having a first inlet and a first outlet,
- the second medium chamber having a second inlet and a second outlet,
- the first medium chamber, the second medium chamber and the intermediate chamber being defined by a plurality of chamber plates having a configuration, wherein the configuration of each chamber plate is substantially identical irrespective of which chamber it is part of.

2. A dual media safety heat exchanger according to

- claim 1, wherein the heat exchanger comprises a plurality of first medium chambers, a plurality of second medium chambers and a plurality of intermediate chambers, all being arranged in a stacked manner.
3. A dual media safety heat exchanger according to claim 1 or 2, wherein the chamber plates are made from a blank material.
4. A dual media safety heat exchanger according to claim 3, wherein the material is metal, preferably aluminium or any alloys thereof.
5. A dual media safety heat exchanger according to any of the preceding claims, wherein the first inlet and the first outlet are extending through the stacked chamber plates and provide a first inlet channel and a first outlet channel being fluidly connected with the plurality of first medium chambers, the second inlet and the second outlet are extending through the stacked chamber plates and provide a second inlet channel and a second outlet channel being fluidly connected with the plurality of second medium chambers.
6. A dual media safety heat exchanger according to claim 5, wherein the first inlet channel is configured to distribute the first medium to all the first medium chambers, and the second inlet channel is configured to distribute the second medium to all the second medium chambers.
7. A dual media safety heat exchanger according to claim 5 or 6, wherein the first medium chambers are arranged in parallel in relation to the first inlet channel, and the second medium chambers are arranged in parallel in relation to the second inlet channel.
8. A dual media safety heat exchanger according to any of the preceding claims, wherein embossments have been provided in the chamber plates, the embossments being herringbone-shaped.
9. A dual media safety heat exchanger according to claim 5, wherein each chamber plate is substantially square-formed provided with four apertures at each corner, the apertures are configured to define the first inlet channel, the first outlet channel, the second inlet channel and the second outlet channel, respectively.
10. A dual media safety heat exchanger according to claim 9, wherein the chamber plate has a centre axis, two of the apertures are arranged on a first side of the centre axis and the other two apertures are arranged on a second side of the centre axis, the second side being opposite side of the first side in relation to the centre axis.
11. A dual media safety heat exchanger according to claim 9 and/or 10, wherein the two apertures arranged on the first side being the first apertures have a first diameter, the two apertures arranged on the second side being the second apertures have a second diameter, the first diameter being larger than the second diameter.
12. A dual media safety heat exchanger according to any of the claims 9 to 11, wherein the chamber plate has a first face and a second face, first rim sections are provided around the first apertures, the first rim sections are projecting from the first face having a first distance, second rim sections are provided around the second apertures, the second rim sections are extending from the second face having a second distance.
13. A dual media safety heat exchanger according to claim 12, wherein the second distance is larger than the first distance, preferably the second distance is at least twice the distance of the first distance.
14. A dual media safety heat exchanger according to any of the preceding claims, wherein a first end plate is arranged on a first end of the stacked chamber plates, and a second end plate is arranged on a second end of the stacked chamber plates.
15. A method for preparing a dual media safety heat exchanger according to any of the preceding claims, comprising
- providing a plurality of chamber plates being substantially identical,
 - providing a first chamber plate,
 - providing a second chamber plate,
 - stacking the second chamber plate on top of the first chamber plate by arranging the second face of the first chamber plate opposite to the second face of the second chamber plate while aligning the first apertures of the first chamber plate with the second apertures of the second chamber plate,
 - providing a third chamber plate,
 - stacking the third chamber plate on top of the second chamber plate by arranging the first face of the third chamber plate opposite to the first face of the second chamber plate while aligning the second apertures of the second chamber plate with the second apertures of the third chamber plate,
 - providing a fourth chamber plate,
 - stacking the fourth chamber plate on top of the third chamber plate by arranging the second face of the third chamber plate opposite to the

second face of the fourth chamber plate while aligning the first apertures of the third chamber plate with the second apertures of the fourth chamber plate,

- continuing stacking chamber plates in the same manner until a predetermined size of the heat exchanger is obtained, and
- connecting the chamber plates in a fluid tight manner providing the first medium chambers, the second medium chamber and the intermediate chambers.

5

10

15

20

25

30

35

40

45

50

55

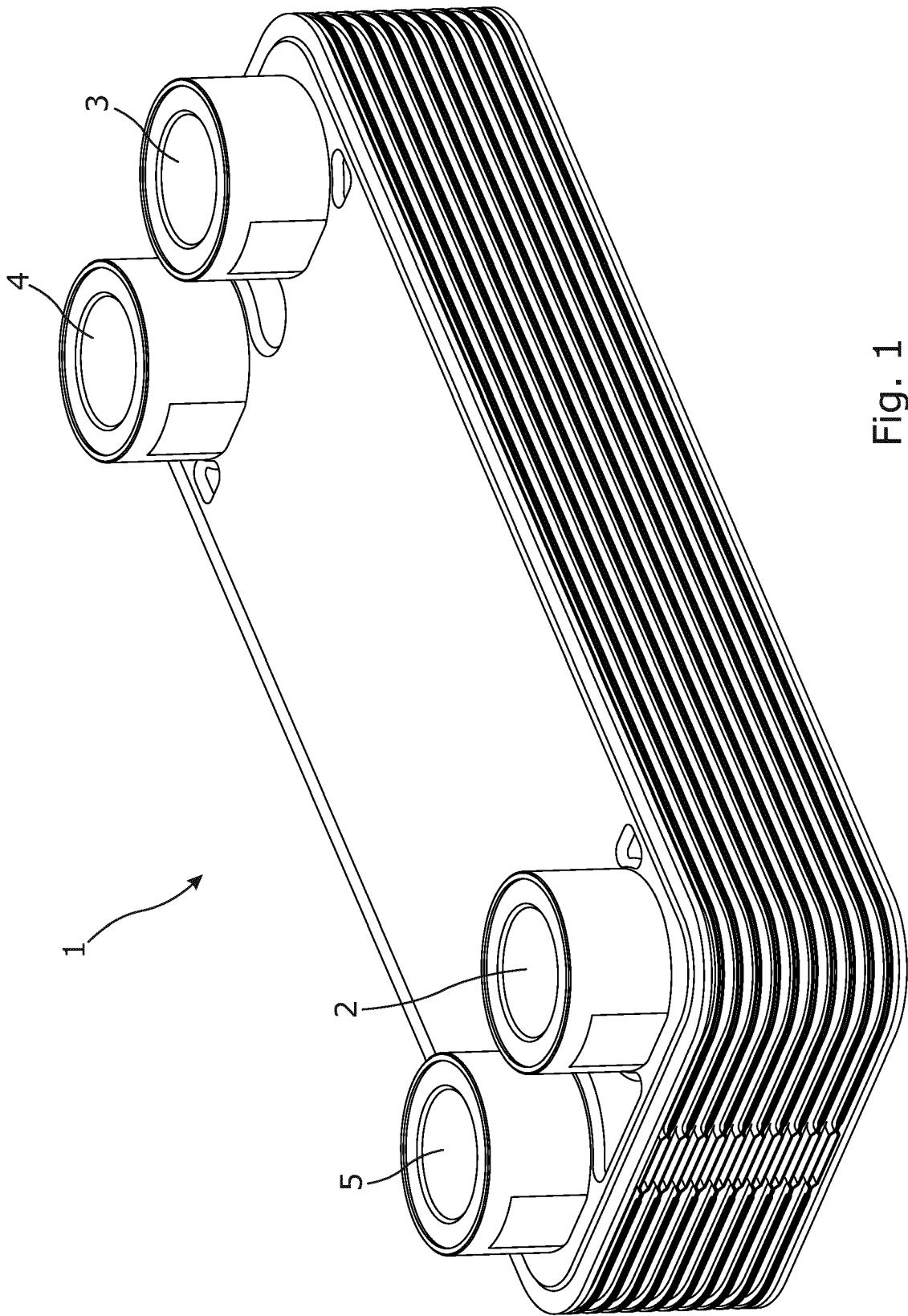

Fig. 1

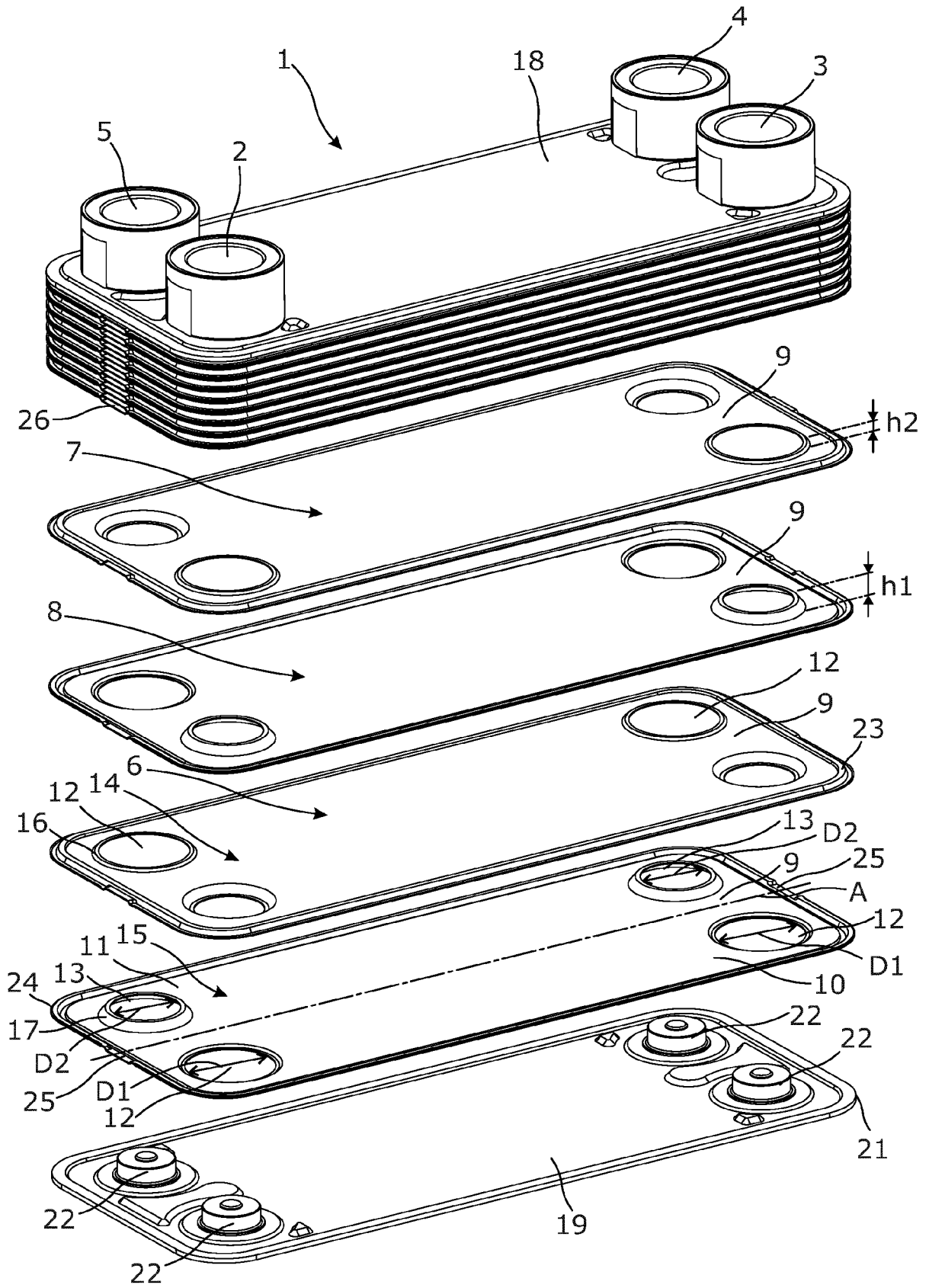

Fig. 2

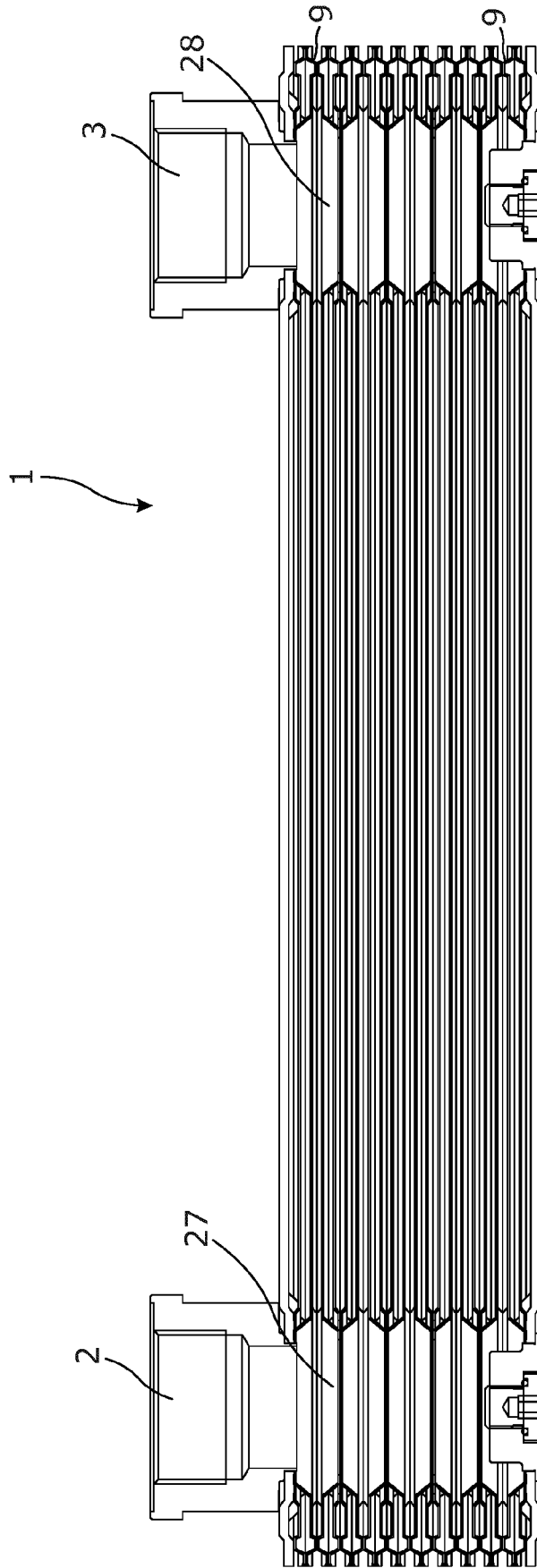

Fig. 3

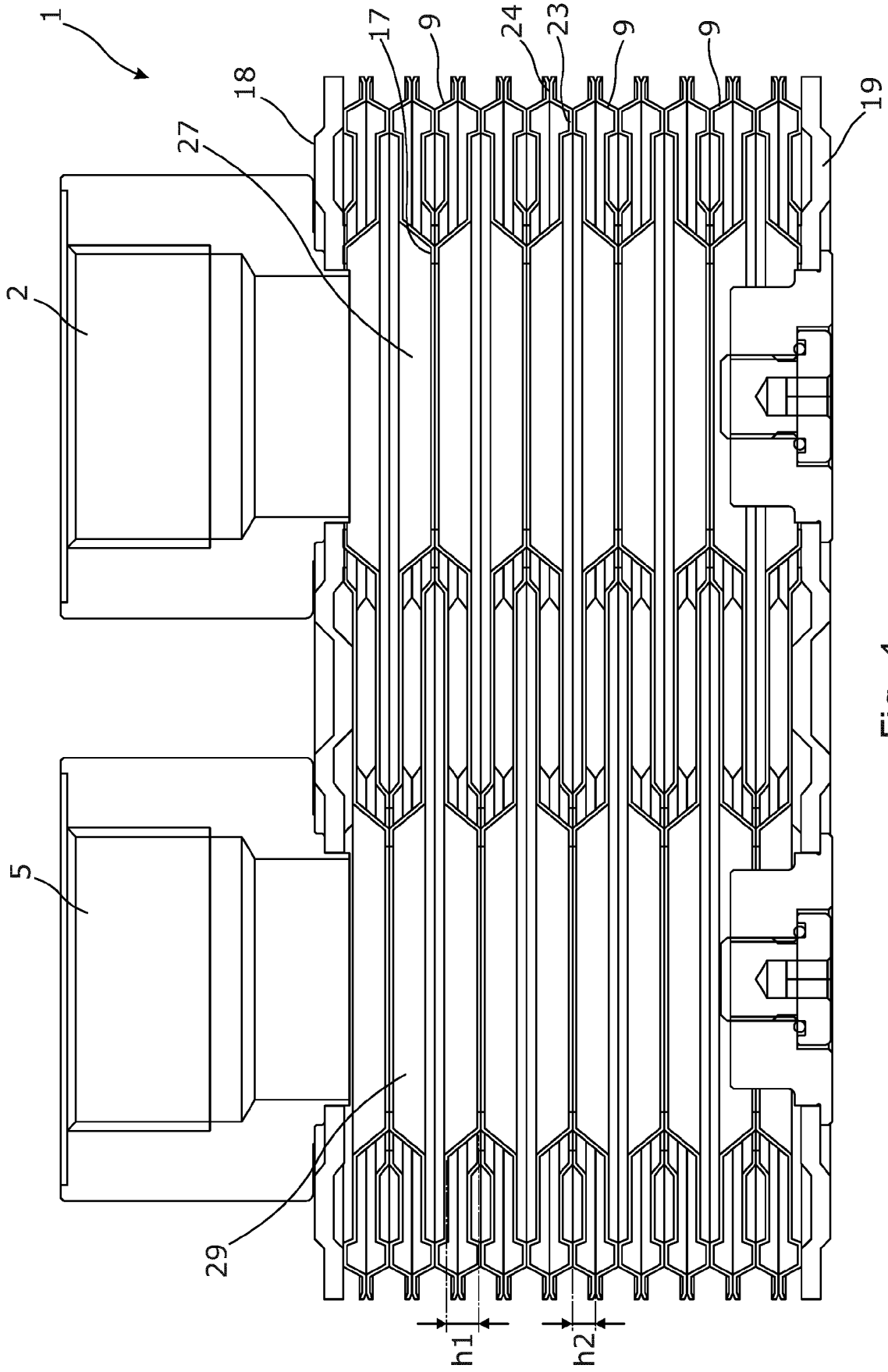

Fig. 4

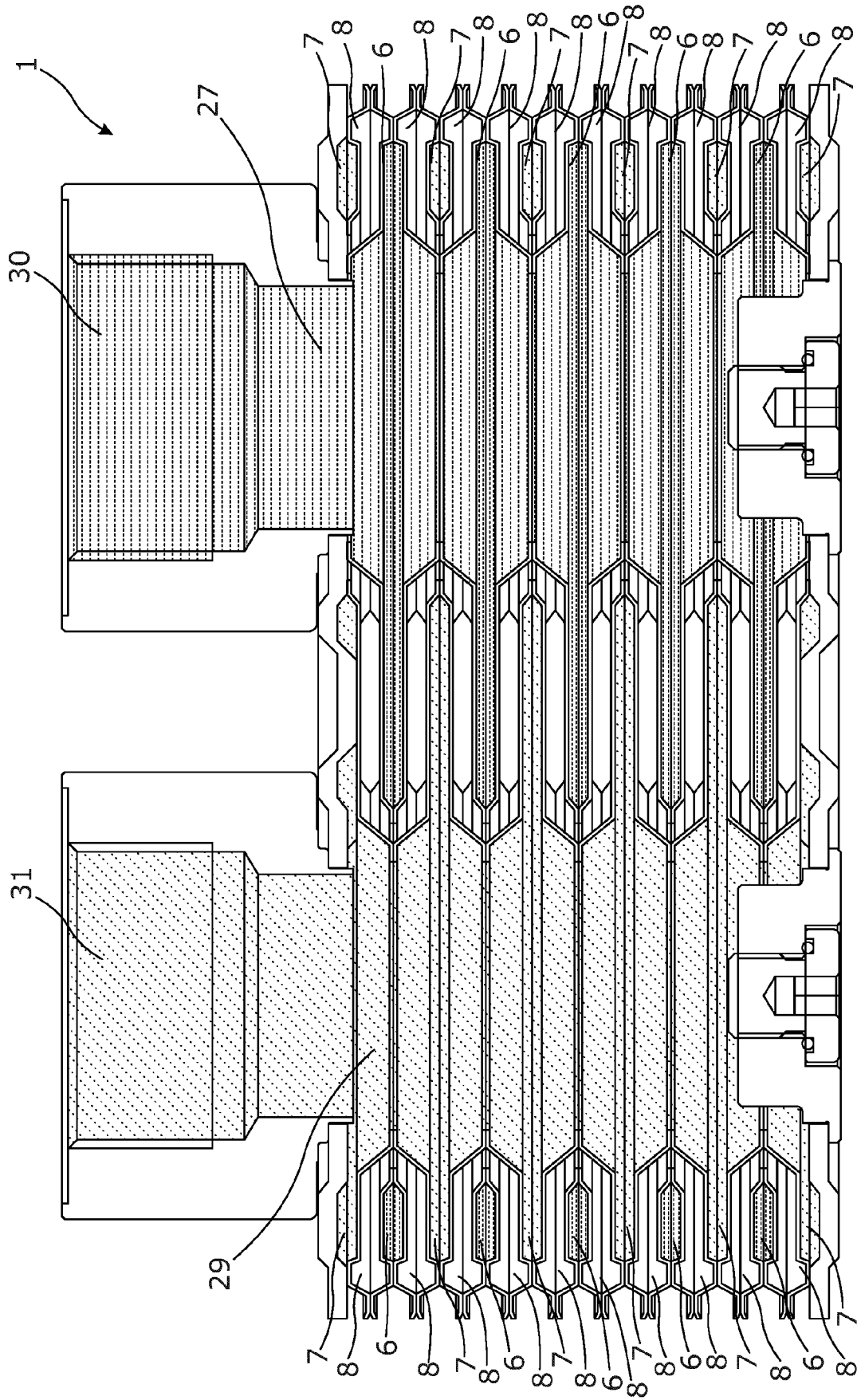

Fig. 5

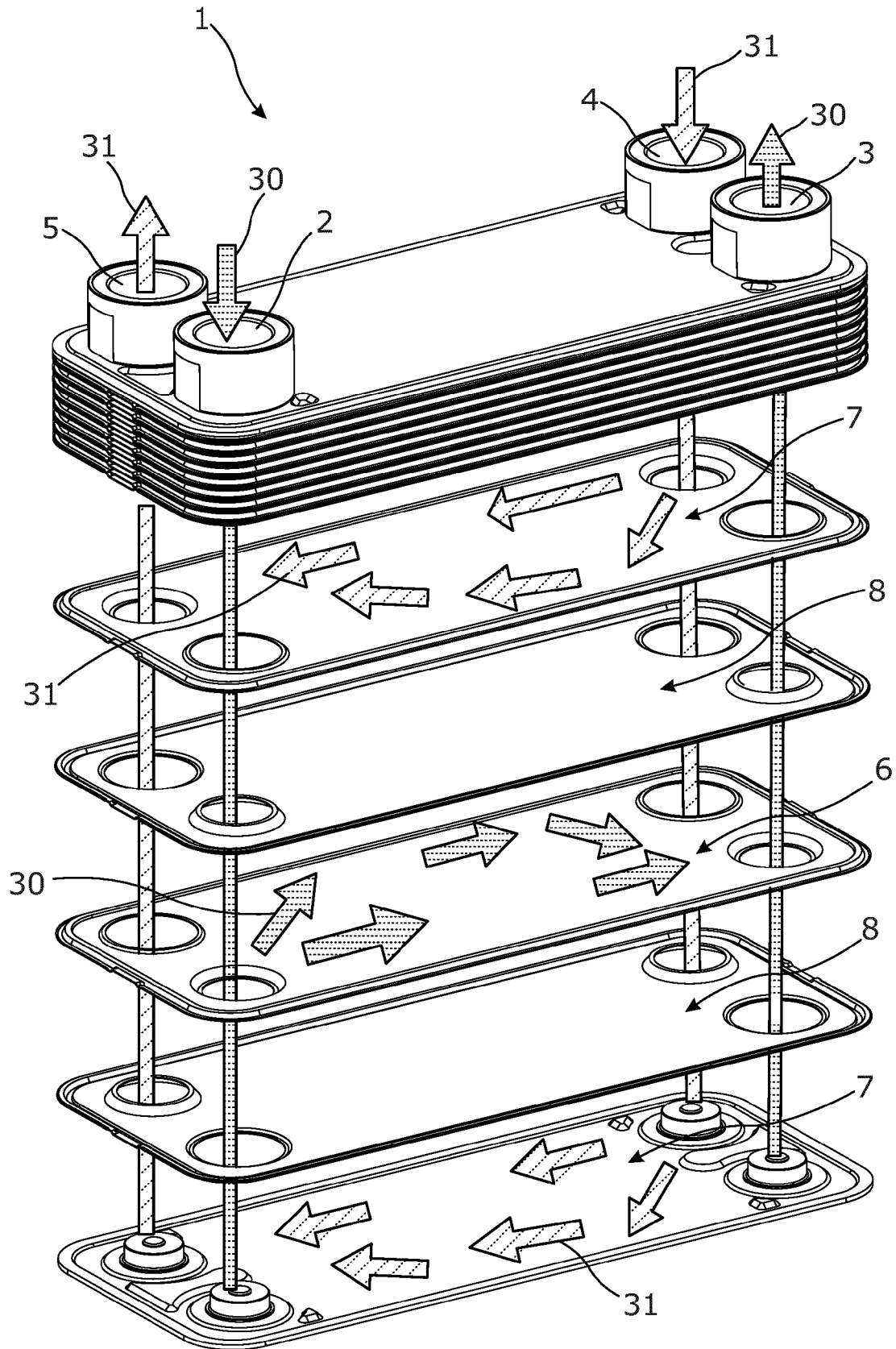

Fig. 6

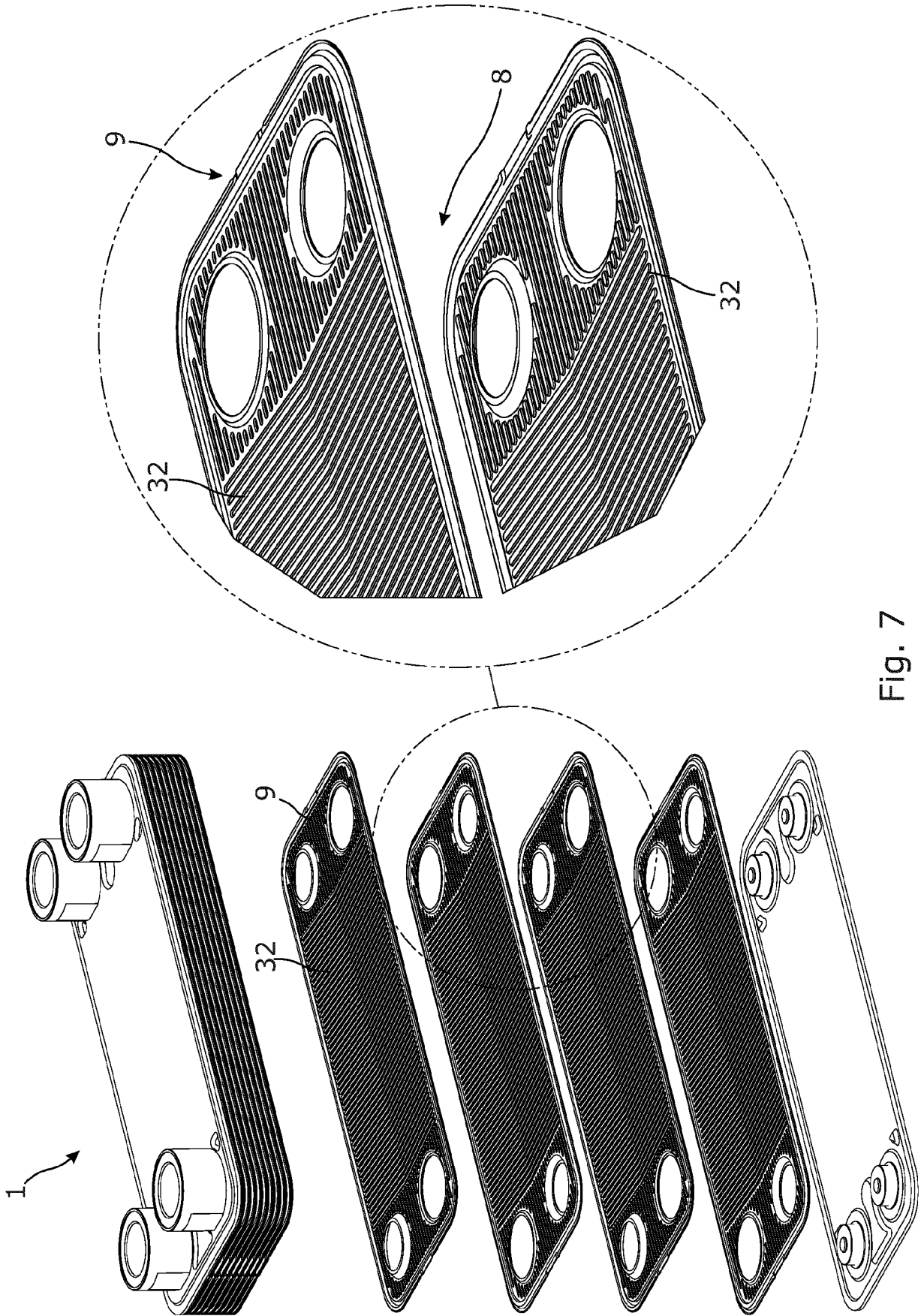

Fig. 7

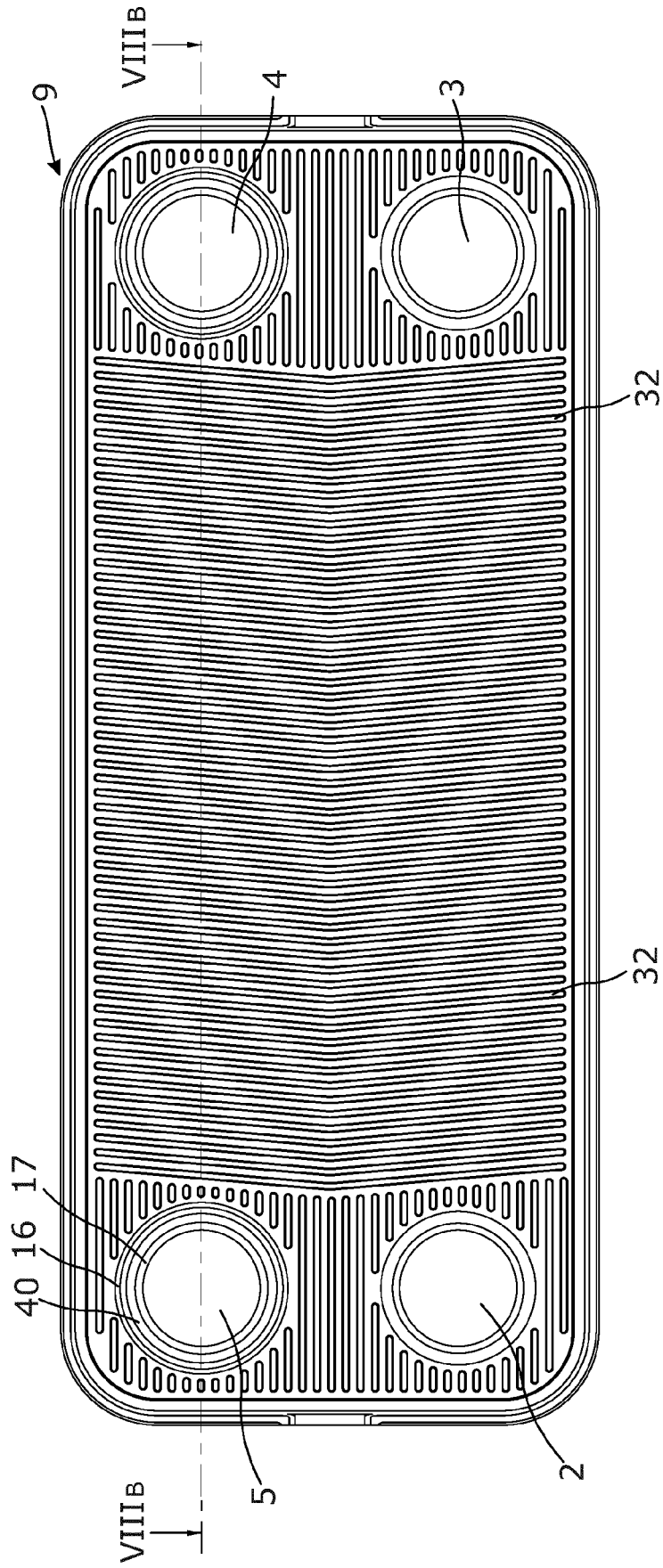

Fig. 8a

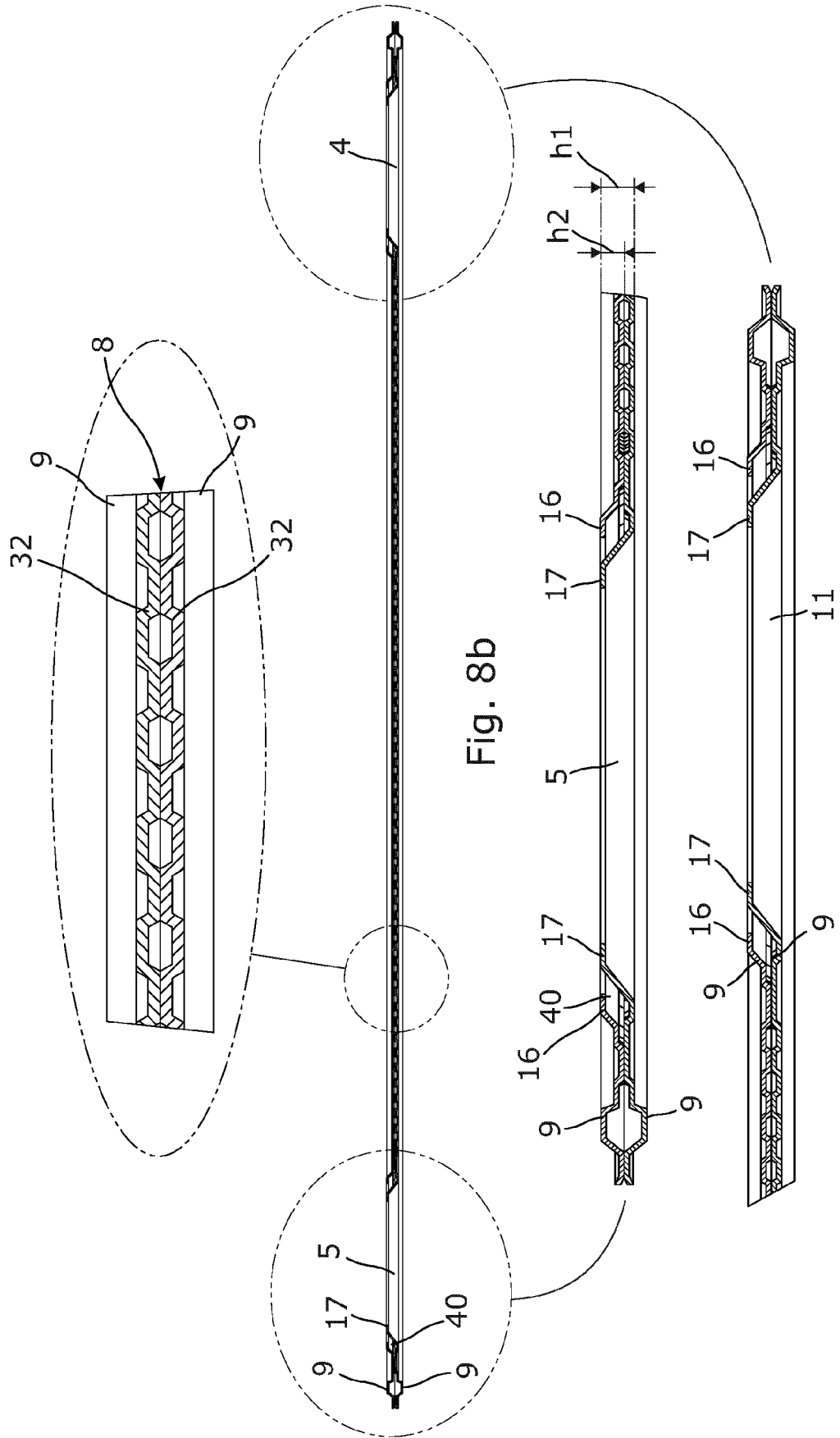

Fig. 8b



EUROPEAN SEARCH REPORT

Application Number
EP 19 17 7262

5

10

15

20

25

30

35

40

45

50

55

DOCUMENTS CONSIDERED TO BE RELEVANT			
Category	Citation of document with indication, where appropriate, of relevant passages	Relevant to claim	CLASSIFICATION OF THE APPLICATION (IPC)
X	EP 1 811 255 A2 (FLATPLATE INC [US]) 25 July 2007 (2007-07-25) * pages 5-8; figures 1-8 * -----	1-15	INV. F28D9/00 F28F1/00
A	EP 1 469 270 A1 (REHBERG PETER DIPL ING [DE]; LAUER RALF DIPL ING [DE]) 20 October 2004 (2004-10-20) * page 3; figures 1-3 * -----	1-15	
A	WO 2018/210392 A1 (UNDERWOOD CHRISTOPHER [DK]) 22 November 2018 (2018-11-22) * pages 2-3; figures 1-3 * -----	1-15	
A	EP 0 252 275 A2 (SCHMIDT W GMBH CO KG [DE]) 13 January 1988 (1988-01-13) * pages 2-3; figures 1-3 * -----	1-15	
A	EP 1 526 350 A2 (MODINE MFG CO [US]) 27 April 2005 (2005-04-27) * page 3; figures 1-8 * -----	1-15	
			TECHNICAL FIELDS SEARCHED (IPC)
			F28D F28F
The present search report has been drawn up for all claims			
Place of search Munich		Date of completion of the search 29 November 2019	Examiner Merkt, Andreas
<p>CATEGORY OF CITED DOCUMENTS</p> <p>X : particularly relevant if taken alone Y : particularly relevant if combined with another document of the same category A : technological background O : non-written disclosure P : intermediate document</p> <p>T : theory or principle underlying the invention E : earlier patent document, but published on, or after the filing date D : document cited in the application L : document cited for other reasons & : member of the same patent family, corresponding document</p>			

EPO FORM 1503 03/82 (P04/C01)

ANNEX TO THE EUROPEAN SEARCH REPORT
ON EUROPEAN PATENT APPLICATION NO.

EP 19 17 7262

5

This annex lists the patent family members relating to the patent documents cited in the above-mentioned European search report. The members are as contained in the European Patent Office EDP file on The European Patent Office is in no way liable for these particulars which are merely given for the purpose of information.

29-11-2019

10

15

20

25

30

35

40

45

50

55

Patent document cited in search report	Publication date	Patent family member(s)	Publication date
EP 1811255 A2	25-07-2007	BR PI0700007 A	06-11-2007
		CN 101004329 A	25-07-2007
		EP 1811255 A2	25-07-2007
		JP 2007192534 A	02-08-2007
		US 2007169916 A1	26-07-2007

EP 1469270 A1	20-10-2004	AT 498103 T	15-02-2011
		CA 2463795 A1	14-10-2004
		CN 1550745 A	01-12-2004
		DE 10317263 A1	04-11-2004
		DK 1469270 T3	23-05-2011
		EP 1469270 A1	20-10-2004
		ES 2361012 T3	13-06-2011
		HK 1072803 A1	04-11-2011
		NZ 532299 A	27-08-2004
		PL 1469270 T3	29-07-2011
		US 2004200607 A1	14-10-2004

WO 2018210392 A1	22-11-2018	NONE	

EP 0252275 A2	13-01-1988	DE 3622316 C1	28-01-1988
		EP 0252275 A2	13-01-1988
		JP S6325494 A	02-02-1988
		US 4781248 A	01-11-1988

EP 1526350 A2	27-04-2005	DE 10348803 A1	25-05-2005
		EP 1526350 A2	27-04-2005
		US 2005082049 A1	21-04-2005
