



(12) **EUROPEAN PATENT APPLICATION**

(88) Date of publication A3:  
**29.03.2006 Bulletin 2006/13**

(51) Int Cl.:  
**A47K 3/40<sup>(2006.01)</sup>** **A47K 3/16<sup>(2006.01)</sup>**  
**A47K 3/17<sup>(2006.01)</sup>**

(43) Date of publication A2:  
**01.02.2006 Bulletin 2006/05**

(21) Application number: **05021855.1**

(22) Date of filing: **30.11.2000**

(84) Designated Contracting States:  
**AT BE CH CY DE DK ES FI FR GB GR IE IT LI LU  
MC NL PT SE TR**  
Designated Extension States:  
**AL LT LV MK RO SI**

(71) Applicant: **Adamsez (N.I.) Limited**  
**Belfast BT16 0TQ,**  
**County Down (GB)**

(30) Priority: **01.12.1999 GB 9928347**

(72) Inventor: **Dunlop, Lawrence James**  
**Belfast BT16 0TQ (GB)**

(62) Document number(s) of the earlier application(s) in  
accordance with Art. 76 EPC:  
**00650201.7 / 1 104 662**

(74) Representative: **Hanna, John Philip et al**  
**MacLachlan & Donaldson**  
**47 Merrion Square**  
**Dublin 2 (IE)**

(54) **Shower tray**

(57) A shower tray has a central basin (10) with an upstanding wall surround (12), a ledge surround (11) and a depending lip (14). The undersurface of the basin (10) and the undersurface of the ledge surround (11) are both provided with a board reinforcement (16, 18) incorporat-

ed thereinto. The tray has a plurality of height-adjustable feet (20) provided spaced around the ledge surround reinforcement (18) with at least one height-adjustable foot (20) positioned substantially centrally of the basin reinforcement (16).

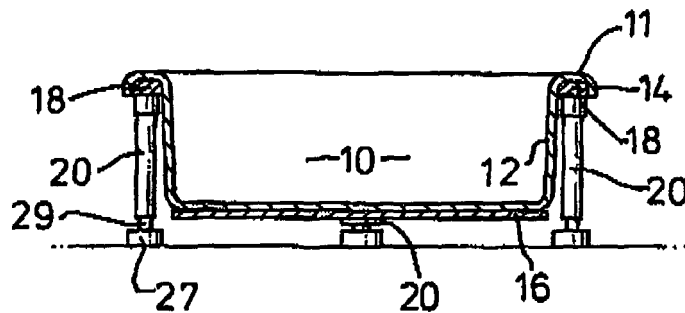

**FIG. 2.**



DOCUMENTS CONSIDERED TO BE RELEVANT			
Category	Citation of document with indication, where appropriate, of relevant passages	Relevant to claim	CLASSIFICATION OF THE APPLICATION (IPC)
X	GB 1 572 798 A (TRENT VALLEY ENG LTD) 6 August 1980 (1980-08-06) * the whole document * -----	1-4	A47K3/40 A47K3/16 A47K3/17
X A	FR 2 208 630 A (TRENNER OTTO,OE) 28 June 1974 (1974-06-28) * the whole document * -----	1,3,4 2	
X Y	GB 2 318 049 A (CORAM) 15 April 1998 (1998-04-15) * page 2, paragraph 4 - page 4; figures * -----	1,3,4 2,5,6	
Y A	DE 44 43 876 A1 (LIDO HOLDING GMBH) 4 April 1996 (1996-04-04) * column 5, line 18 - line 64; figures 7-9 * -----	2,5,6 3,7	
Y	EP 0 281 957 A1 (BAMBERGER GMBH & CO KG GEB) 14 September 1988 (1988-09-14) * column 3, line 38 - column 4, line 51; figures * -----	2,5	TECHNICAL FIELDS SEARCHED (IPC) A47K
A	US 5 915 850 A (KRIST ET AL) 29 June 1999 (1999-06-29) * the whole document * -----	1-4	
P,X	GB 2 337 697 A (SPRING RAM HOLDINGS PLC) 1 December 1999 (1999-12-01) * page 4, paragraph 3 - page 5, paragraph 1; figure 2 * -----	1,3,4	
P,X	GB 2 348 600 A (* BENDZ LIMITED) 11 October 2000 (2000-10-11) * page 5, paragraph 1 - page 7, paragraph 3; figure 6 * -----	1,2	
The present search report has been drawn up for all claims			
Place of search Munich		Date of completion of the search 6 February 2006	Examiner Fajarnés Jessen, A
CATEGORY OF CITED DOCUMENTS X : particularly relevant if taken alone Y : particularly relevant if combined with another document of the same category A : technological background O : non-written disclosure P : intermediate document		T : theory or principle underlying the invention E : earlier patent document, but published on, or after the filing date D : document cited in the application L : document cited for other reasons ..... & : member of the same patent family, corresponding document	

ANNEX TO THE EUROPEAN SEARCH REPORT  
ON EUROPEAN PATENT APPLICATION NO.

EP 05 02 1855

This annex lists the patent family members relating to the patent documents cited in the above-mentioned European search report. The members are as contained in the European Patent Office EDP file on  
The European Patent Office is in no way liable for these particulars which are merely given for the purpose of information.

06-02-2006

Patent document cited in search report		Publication date	Patent family member(s)	Publication date
GB 1572798	A	06-08-1980	NONE	
FR 2208630	A	28-06-1974	BE 806747 A1	15-02-1974
			DE 2353526 A1	09-05-1974
			IT 999051 B	20-02-1976
			NL 7314858 A	02-05-1974
GB 2318049	A	15-04-1998	NONE	
DE 4443876	A1	04-04-1996	DE 9415843 U1	30-03-1995
EP 0281957	A1	14-09-1988	DE 3707647 A1	22-09-1988
US 5915850	A	29-06-1999	AT 240672 T	15-06-2003
			DE 29706518 U1	22-05-1997
			EP 0870459 A2	14-10-1998
			ES 2194246 T3	16-11-2003
GB 2337697	A	01-12-1999	NONE	
GB 2348600	A	11-10-2000	NONE	