

J. Browning, Reed Setting Mach.

No. 107,865.

Patented Oct. 4, 1870.

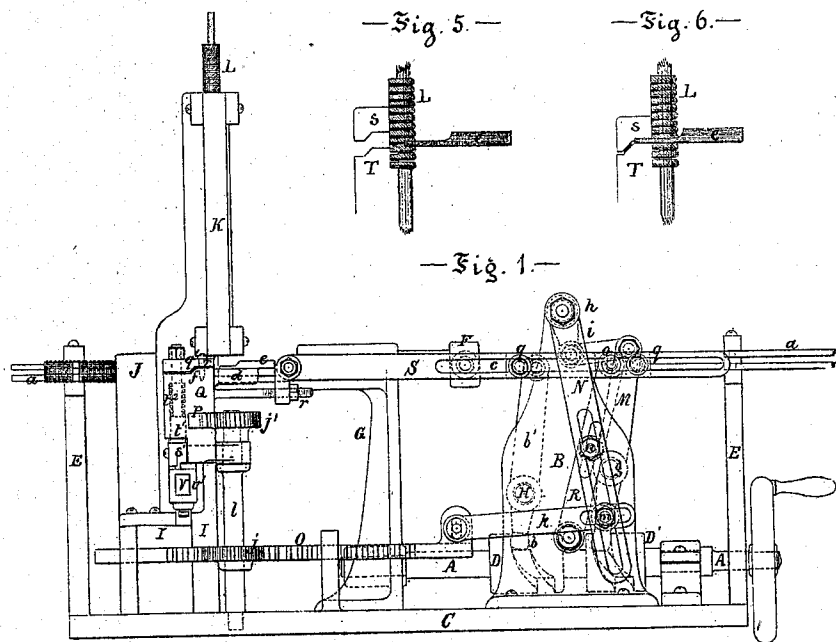

— Fig. 5. —

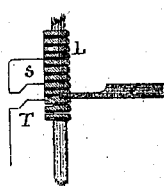

— Fig. 6. —

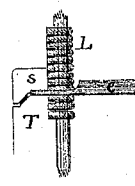

— Fig. 1. —

— Fig. 2. —

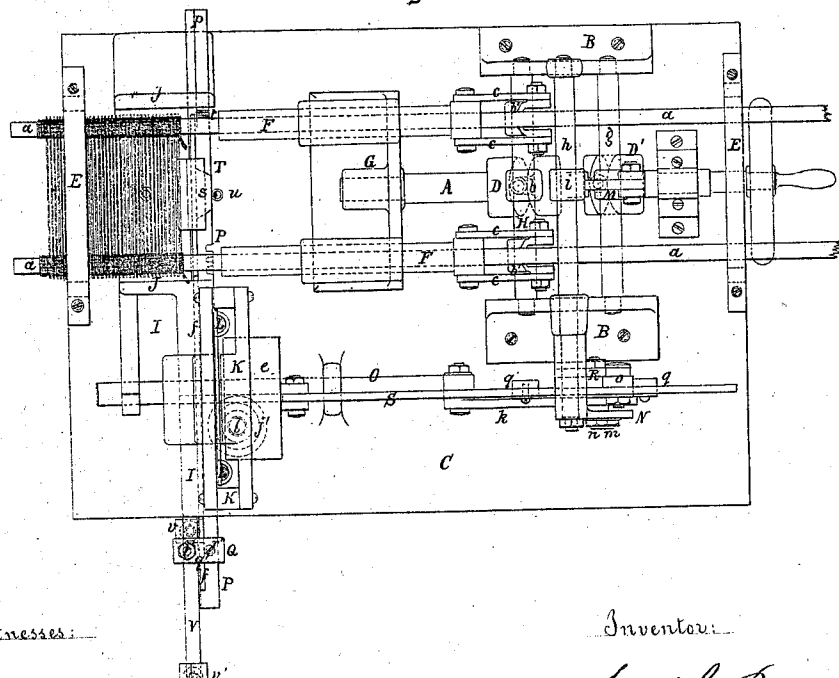

Witnesses:

Samuel Cropley
Theodore Berger

Inventor:

Joseph Browning

J. Browning, Need Setting Mach.

No. 107,865.

Patented Oct. 4, 1870.

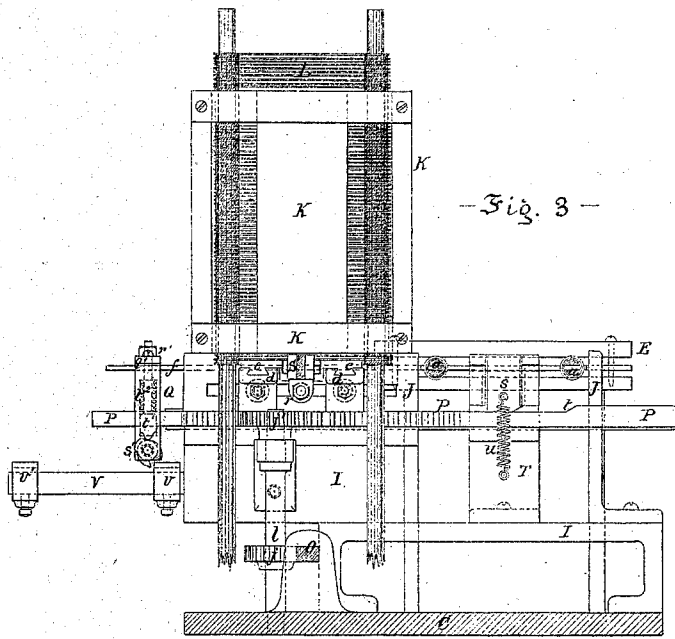

- Fig. 3 -

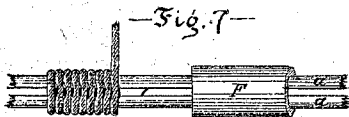

- Fig. 7 -



- Fig. 8 -

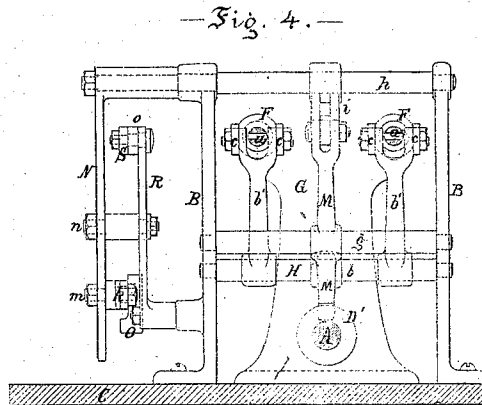

- Fig. 4 -

Samuel Cropley }
 Theodore Bergner } Witnesses

Inventor:
 Joseph Browning

United States Patent Office.

JOSEPH BROWNING, OF PHILADELPHIA, PENNSYLVANIA.

Letters Patent No. 107,865, dated October 4, 1870.

IMPROVEMENT IN REED-SETTING MACHINES.

The Schedule referred to in these Letters Patent and making part of the same

I, JOSEPH BROWNING, of the city of Philadelphia, State of Pennsylvania, have invented certain Improvements in Machines for Setting and Resetting Reeds, of which the following is a specification.

Nature and Objects of the Invention.

The first part of my invention relates to combining, with the ordinary mechanism of a reed-setting machine, a self-acting device for detaching the splits from old reeds, and delivering the same to the machine for resetting, without handling.

The second part of my invention consists in the adaptation of a part of my improved resetting device for feeding new splits to the setting-machine from a continuous coil of prepared wire.

Description of the Accompanying Drawing.

Figure 1, sheet 1, is a side elevation of a machine embodying my invention.

Figure 2, sheet 1, is a plan of the same.

Figure 3, sheet 2, is an elevation showing that part of the machine which is at the left-hand end in fig. 1.

Figure 4, sheet 2, is an end view of the driving machinery, near the right-hand end of fig. 1.

Figures 5 and 6, sheet 1, are detached views of the parts for separating the splits from old reeds, and carrying them to the new ribs for resetting.

Figures 7 and 8, sheet 2, are detached views illustrative of the manner of entering the splits between the ribs in an inclined position, and of the manner of increasing the tension of the lapping by the action of the drivers.

A is the main driving-shaft of the machine.

B B are frames secured to the bed-plate C, and carrying the various rock-shafts and vibrating arms actuated by cams D D' on shaft A, and giving motion to the combined mechanism of the machine.

The ribs *a a* placed into the machine to form a new reed, are held in frames E E at each end of the machine.

F F are the drivers, consisting of hollow tubular sleeves, carried in a frame, G. The two pairs of ribs *a a* pass freely through these drivers, to which a reciprocating movement is imparted from the grooved cam D by means of levers *b b'*, rock-shaft H, and links *c c*.

Upon an open frame, I, at the left-hand end of fig. 1, are provided two parallel side pieces, J J, for guiding the finished end of the reed through the machine. The same frame-work also carries a vertical guide-structure, K, for steadying the old reed L in its downward course through the machine.

The mechanism for detaching the splits from the old reed, and for conducting the same (or the new splits, as the case may be,) to the new reed for set-

ting, is also mainly attached to frame I, beneath the guide K.

The only preparation required in the old reed L to fit it for passing through the self-acting resetting mechanism of my machine, is the same as that required for the ordinary method of removing the splits by hand, and consists in removing one side of each rib of the reed by cutting lengthwise through the lapping between the part to be removed and the splits, (see fig. 2.) The remaining portion of the lapping suffices to hold the splits firmly enough to the remaining side of the ribs.

The old reed thus prepared, and having all crooked or defective splits removed, is stood upright into the guide-frame K, its undermost split resting upon an entablature, *d*.

e is a sliding plate, having V-bearings in the entablature *d*, on which it slides in the manner fully apparent from figs. 1, 5 and 6.

The thin forward end of slide *e*, being on a level with the lowest split, carries the latter with it in moving forward, and deposits it in an inclined groove corresponding with the position of the removed split shown in fig. 6.

As the slide *e* is withdrawn to the position seen in fig. 5, the reed L descends by gravitation, bringing its next lowest split to rest on *d*, to be in turn detached by the next forward motion of *e*. Each split thus removed from the old reed and deposited in the rear, is removed in an endwise direction by a feeding-bar, *f*, which pushes it forward and places it between the ribs of the new reed ready for the final operation of setting by means of the drivers F F.

The slide *e* and feeding-bar *f* receive each their reciprocating motion from a grooved cam, D', on driving-shaft A, in the following manner:

A double-armed lever, M, on a rock-shaft, *g*, communicates the motion given to its lower arm by the cam D' to an upper rock-shaft, *h*, which, by reason of the relative length of its arm *i* to the greater length of arm M, receives a much increased throw.

This vibration of shaft *h* imparts, by means of its long outer arm N and link *k*, a reciprocating movement to a longitudinally-sliding rack, O, which through toothed pinions *j j'* on an upright shaft, *l*, again gives a reciprocating movement to a laterally-sliding rack, P, which carries, on a head-block, Q, the above-mentioned feeding bar *f*. The amount of the motion thus given to feed-bar *f* is easily and nicely adjustable by setting the pin *m* (which joints link *k* to arm N) to any desired throw within the slot in arm N. This same arm carries a second adjustable pin, *n*, which imparts a vibrating movement to a shorter arm, R; this arm, having its fulcrum below, vibrates in the opposite direction to arm N; it carries at its upper

end a swivel-block *o*, which is arranged to slide freely within a slot in a long, slender bar, *S*, attached at one end to the slide *e*, to which it imparts, at proper intervals, the required short, sudden motion for removing the lowest split from reed *L*, and depositing it in front of the feeding-bar *f*, to be carried to the resetting mechanism. This sudden motion of bar *S* is due to the bringing up of block *o* against adjustable stops *q q*, the relative position of which stops on *S*, determines and regulates the amount of motion imparted to slide *e*.

r is an adjustable stop-nut under the entablature *d*, against which the slide *e* is arrested in its backward movement.

T is a stand (see figs. 2 and 3) supported on frame *I*, between the ribs *a a* and drivers *F F*; it carries in *V*-guides a vertically-sliding piece *s*, which is lifted at each backward stroke of the rack *P*, by means of a short, inclined plane *t* on the rack, entering under a suitably inclined surface on the bottom of *s*.

A spiral spring, *u*, serves to move and hold down the slide *s* when released from the action of the inclined plane *t*.

The slide *s* has, at its rear under side, an inclined bearing-surface, resting upon a similarly-inclined surface on stand *T*, and between these surfaces the split about to be set is inserted by the feeding-bar *f*, and here held down in this inclined position by the tension of spring *u*, until it is suddenly released by the incline *t* on the rack *P*, at the moment the drivers *F F* approach to carry it forward and set it in its final perpendicular position between the lapping and ribs of the reed.

The machinery required for winding the lapping around the ribs between the splits, and also the mechanism for controlling the speed of the endwise motion of the reed and its consequent gradations or fineness of set, requiring no change from any of the known constructions of these parts, and, therefore, not entering into my improvements, are not further shown and described in this connection.

It will readily be seen that the old reed, to have its splits removed by my improved mechanism, may be of any degree of fineness as compared to the new reed about being set, as the old reed passes through the machine by gravitation at a speed due to its own fineness of divisions, quite independent of the gradations of the new reed being set.

By an easily effected change in my improved mechanism, the machine may be readily adapted to the setting of reeds with new wire from a continuous coil. To this end I first disconnect and withdraw the slide *e*, and also the feeding-bar *f*, and then arrange the head-block *Q* to feed the new splits, without any change in the reciprocating motion of rack *P*, in the following manner:

Below the block *Q*, in line with the rack *P*, is provided a stationary bar, *V*, projecting outward from the frame *I*. To this bar are fitted two lengthwise-adjustable stops, *v v'*. The upper clamping-piece *g'*, on *Q*, which before held the feeding-bar *f* permanently secure by means of screw *r'*, is now so actuated by the said stops *v v'* through means of a cam, *s'*, and vertically-sliding spring-pin *t'*, as to alternately grasp and release the continuous split-wire at each termination of its stroke. Thus, during the forward stroke of the rack *P*, the split is carried with it by the clamping action of the piece *g'*, which is held down by means of the spiral spring *t'*. At the termination of the forward stroke, however, the outer projection or nose on cam *s'* comes in contact with stop *v*, and *s'* is thus turned upon its axis sufficient to cause its upper cam surface to lift the pin *t'* against the tension of spring *t'*, thereby releasing the split-wire from the clamping-piece *g'*, which returns empty, until, at the termination of the back stroke, the cam *s'* is actuated in the opposite direction by the outer stop *v'*, and the pin *t'* and clamp *g'* released from the cam *s'*, so that the split-wire is grasped anew by the clamp *g'*, which again carries it along with its next forward stroke, &c.

Any small shearing device, not represented in the drawing, but actuated as usual by the nearest driver during the first part of its forward stroke, serves to cut off each split at the required place and moment.

The whole of this above mechanism for feeding splits from continuous wire may be disengaged by simply placing the stops *v v'* far enough apart on the bar *V* to allow the full stroke of the rack *P*, without cam *s'* touching the stops. To change back to resetting old splits, I then only insert the feeding-bar *f*, and connect the slide *e* with the other machinery.

Having thus described the nature and objects of my invention,

I do not confine myself to the described detail of mechanism in every minutia, since the same may be modified, or equivalents substituted, without impairing my invention.

Claims.

I claim as my invention—

1. The slide *e* and feed-bar *f*, or their equivalents, combined and operating as described, to remove a split from an old reed and place it between the ribs of a new one.

2. The stops *v v'*, cam *s'*, and rack *P*, or their equivalents, for actuating the clamping-piece *g'*, substantially in the manner and for the purpose set forth.

JOSEPH BROWNING.

Witnesses:

SAMUEL CROSSLEY,
THEODORÉ BERGNER.