



(11) **EP 3 299 536 B1**

(12) **EUROPEAN PATENT SPECIFICATION**

(45) Date of publication and mention of the grant of the patent:
11.12.2019 Bulletin 2019/50

(51) Int Cl.:
E04D 13/035 (2006.01)

(21) Application number: **17192608.2**

(22) Date of filing: **22.09.2017**

(54) **A ROOF WINDOW INCLUDING A SET OF HINGES WITH IMPROVED MOVEMENT PATTERN**

DACHFENSTER MIT EINEM SATZ VON SCHARNIEREN MIT VERBESSERTEM BEWEGUNGSMUSTER

FENÊTRE DE TOIT COMPRENANT UN ENSEMBLE DE CHARNIÈRES AYANT UNE SÉQUENCE DE MOUVEMENT AMÉLIORÉE

(84) Designated Contracting States:
AL AT BE BG CH CY CZ DE DK EE ES FI FR GB GR HR HU IE IS IT LI LT LU LV MC MK MT NL NO PL PT RO RS SE SI SK SM TR

(30) Priority: **23.09.2016 DK 201670757**

(43) Date of publication of application:
28.03.2018 Bulletin 2018/13

(73) Proprietor: **VKR Holding A/S**
2970 Hørsholm (DK)

(72) Inventor: **Holm, Michael Galsgård**
4000 Roskilde (DK)

(74) Representative: **AWA Denmark A/S**
Strandgade 56
1401 Copenhagen K (DK)

(56) References cited:
EP-A1- 2 770 146 EP-A1- 2 843 148
DE-A1- 2 023 937 US-A- 2 885 745
US-A- 4 446 597 US-A1- 2010 037 526

EP 3 299 536 B1

Note: Within nine months of the publication of the mention of the grant of the European patent in the European Patent Bulletin, any person may give notice to the European Patent Office of opposition to that patent, in accordance with the Implementing Regulations. Notice of opposition shall not be deemed to have been filed until the opposition fee has been paid. (Art. 99(1) European Patent Convention).

Description

Technical Field

[0001] The present invention relates to a roof window comprising a frame with a plurality of frame members defining a frame plane and adapted to be connected to a load-bearing structure of a roof of a building; a sash with a plurality of sash members and carrying a pane defining a sash plane; and a set of hinges connecting the sash with the frame to allow the sash plane to assume an angle relative to the frame plane, each hinge of said set of hinges defining a hinge centre and including a frame hinge part in connection with a frame side member and a sash hinge part in connection with a sash side member and configured to assume an angle relative to the frame hinge part, said set of hinges defining a hinge axis, the sash and frame each having an interior side adapted to face the interior of the building in the mounted condition and an exterior side adapted to face the exterior of the building in the mounted condition.

Background Art

[0002] Basically, roof windows may be provided in a number of varieties and include more or less complicated structures in order to allow opening of the sash and to fulfil other functions, such as ventilation, while permitting cleaning of the outside of the pane from inside the building. The varieties include roof windows of the pivoting type, the hinge axis being either located at the centre or displaced from the centre of the window, and top-hung roof windows that pivot for cleaning by means of an intermediate frame.

[0003] Over recent years, increasing demands to the insulating properties of such windows have entailed a relatively large weight of the pane due to the number of sheets in the glazing. In turn, this increases the moment to be exerted by the user when operating the window by tilting or pivoting the sash about the hinge axis. One solution to reduce the moment would be to move the entire hinge further down, i.e. towards the interior, in the structure. However, as the hinges themselves are traditionally formed by metal, placing the set of hinges at an interior position counteracts the insulating measures, and this solution is furthermore not possible or desirable in all applications.

[0004] US 2 885 745, EP 2 770 146 and EP 2 770 149 all disclose a roof window according to the preamble of claim 1.

Summary of Invention

[0005] With this background it is an object of the present invention to provide a roof window of the kind mentioned in the introduction with respect to the overall operability and insulating properties.

[0006] This and further objects are met by the provision

of a roof window according to claim 1.

[0007] Providing the roof window with a set of hinges of this kind, mounted in an exterior position while so to say reversing the location of the hinge axis, has surprisingly turned out to offer satisfactory operational performance while increasing the thermal properties of the roof window. Increase of the ease of operation is at least partly due to the fact that the hinge axis may be brought relatively close to, if not coinciding with, the centre of gravity of the sash including the pane.

[0008] Hinges having an offset hinge axis relative to the main portion of the hinge itself are well-known as such; a typical example is the classic pivot hinge comprising a guidance and a slide rail defining an axis of rotation offset from the hinge centre. This particular type of pivot hinge is very well-known and is considered as constituting more or less "industry standard" within the field of roof windows. A set of such pivot hinges typically comes as standard on a roof window of the brand VE-LUX®. Alternative hinges include the so-called pantograph or linkage hinge providing a corresponding movement pattern.

[0009] Other presently preferred embodiments and further advantages will be apparent from the following detailed description and the dependent claims.

Brief Description of Drawings

[0010] The invention will be described in more detail below by means of nonlimiting examples of embodiments and with reference to the schematic drawing, in which

Fig. 1 is a perspective view of a prior art window;
 Fig. 2 is a perspective view of a roof window according to a first embodiment of the invention;
 Fig. 3 is a partial perspective view, on a larger scale, of a detail of the roof window of Fig. 2;
 Fig. 4 is a partial perspective view, on a larger scale, of a detail of the roof window of Fig. 2;
 Fig. 5 is a partial plan view, on a larger scale, of the roof window of Fig. 2;
 Fig. 6 is a sectional view along the line VI-VI of Fig. 5;
 Fig. 7 is a perspective view of a roof window according to a second embodiment of the invention;
 Fig. 8 is a partial perspective view, on a larger scale, of a detail of the roof window of Fig. 7;
 Fig. 9 is a partial plan view, on a larger scale, of the roof window of Fig. 7;
 Fig. 10 is a sectional view along the line X-X of Fig. 9.

Description of Embodiments

[0011] In the following, embodiments of the inventive roof window will be described in further detail. For reference, a prior art roof window with a frame 1', a sash 2', a pane 3' and a hinge 10' is shown in Fig. 1. Parts of the prior art roof window which are applicable also to a roof window according to the invention are described in Ap-

plicant's published European patent applications EP 2 770 146 A1 and EP 2 770 149 A1 to which reference is hereby explicitly made.

[0012] Thus, in a manner known per se, the roof window is intended to be built into a surface, which is inclined with respect to the horizontal, typically a roof, and the window will in the following be referred to as roof window. At a position between the top and centre of the window, there is a hinge connection between the frame 1' and the sash 2'. The hinge connection in Fig. 1 comprises a set of two prior art hinges, of which one hinge 10' is visible. The frame 1' and sash 2' is each formed by four members of which one frame side member 11' and one sash side member 21' are indicated. The sash 2' is openable with respect to the frame 1', as the sash 2' may be moved from a closed position, in which e.g. the sash side member 21' is substantially parallel with the frame side member 11', to an open position, in which the sash side member 21' forms an angle with the frame side member 11'. During this movement the sash 2' rotates about a hinge axis α' situated at the hinge connection. As indicated in Fig. 1, the hinge axis α' is located between a centre axis and the top of the roof window, preferably in the interval 1/3 to 2/3 of the distance between the centre axis and the top, most preferred substantially at 1/2 of the distance between the centre axis and the top. Other positions of the hinge axis is of course conceivable, for instance at the centre of the roof window.

[0013] From a closed position, the user operates the operating device of the window. The operating device typically comprises a handle (not shown) connected with the sash bottom member and/or an operating and locking assembly including a ventilation flap at the sash top member with a lock mechanism to interact with a striking plate on the frame top member. The set of hinges 10' exerts a moment on the sash 2', and in combination with the force, and hence moment, exerted by the user operating the operating device, the moment resulting from the weight of the sash 2' and pane 3' is overcome, along with any frictional forces present. All in all, the opening operation entails that the sash 2' is moved from a closed position to an open position as represented by Fig. 1, in which the sash plane forms an opening angle with the frame plane. Closing the window from the open position entails the opposite movement of the sash 2'. It is possible to position the sash 2' in a number of arbitrary opening positions, in which the sash 2' is held stable relative to the frame 1'. The sash 2' is also able to be rotated substantially through 180° to allow cleaning of the outside of the pane 3' from the inside of the building in which the roof window is installed.

[0014] When referring to the Figures, the terms up, down, upwards, downwards, top and bottom are taken relative to how the figures are displayed, that is having the frame arranged in a lying position with the exterior surfaces facing upwards. A front view is taken from the hinge and viewing towards the frame. A view from behind is therefore taken as viewed from the frame towards the

hinge. A direction longitudinal is, if nothing else is mentioned, longitudinal along the length of the frame. It is to be understood that the arrangement shown in a horizontal orientation is not the normal orientation as the window is installed.

[0015] Referring now to Figs 2 to 6, a first embodiment of a roof window according to the invention will be described in detail. Elements having the same or analogous function as in the prior art are denoted by the same reference numerals without the ' mark.

[0016] The hinge 10 comprises a frame hinge part 100 and a sash hinge part 200 configured to assume an angle relative to the frame hinge part 100. The hinge 10 forms part of a set of hinges, of which the frame hinge part 100 of each hinge 10 is configured to be fastened to the frame side member 11 of the frame 1 of the roof window, at a location chosen to provide the desired position of the hinge axis α relative to the height direction of the roof window, i.e. parallel to the side members 11, 21 of the frame and sash, respectively, and the sash hinge part 200 is correspondingly configured to be fastened to the sash side member 21 as will be described in further detail below.

[0017] In the roof window according to the invention, the sash 2 and frame 1 each has an interior side 21i, 11i, respectively, adapted to face the interior, here indicated as an interior space 8, of the building in the mounted condition and an exterior side 21e, 11e, respectively adapted to face the exterior, here indicated as an exterior space 7, of the building in the mounted condition.

[0018] Additional components and parts of relevance include an inward frame surface 11b and an interior frame surface 11i, and an outward sash surface 21b and an interior sash surface 21i. The inward frame surface 11b and the outward sash surface 21b delimit a gap 9 between the frame 1 and the sash 2.

[0019] Referring in particular to the cross-sectional view of Fig. 6, each hinge 10 of said set of hinges defines a hinge centre c. The hinge centre c represents the midpoint of the main operational parts of the hinge, applying to the geometry and/or weight. In the context of the description of the present embodiment, in which the frame hinge part 100 and the sash hinge part 200 each comprises a base plate 110, 210, which specifically is substantially plane, each base plate 110, 210 has a predefined circumference cf, cs, respectively, as shown in Figs 3 and 4. Thus, here the hinge centre c is defined as the geometrical centre of the predefined circumference cf, cs of the base plate 110, 210 of one of, or both, the frame and sash hinge parts 100, 200.

[0020] Thus, according to the present invention, the hinge centre c of each hinge 10 is offset from the hinge axis α , and the set of hinges is arranged such that the hinge centre c of each hinge 10 is located to the exterior of the exterior side 21e, 11e of the sash 2 and frame 1 and the hinge axis α is located to the interior of the exterior side 21e, 11e of the sash 2 and frame 1.

[0021] Whereas it lies within the capacity of the person

skilled in the art to design the dimensions of the hinge components including a specific value of the offsetting of the particular hinge and combine with a suitable positioning of the hinge such that the hinge centre is located to the exterior of the sash and frame of the roof window, it is a prerequisite that the hinge axis α is located to the interior of the exterior side of the sash and frame.

[0022] According to the invention, the distance between the hinge axis α and the hinge centre c lies in the range of 30 to 150 mm, preferably 45 to 120 mm, more preferably 60 to 90 mm. Here, the distance is about 65 mm.

[0023] The distance may be chosen in combination with suitable dimensions of the height of the base plate 110, 210 of the frame hinge part 100 and the sash hinge part 210, respectively. Typically, the height lies in the interval 40 to 80 mm, preferably 50 to 70 mm. The height of the base plate of the sash hinge part may be about 65 mm, somewhat larger than the height of the base plate of the frame hinge part which is typically about 55 mm.

[0024] With the correct configuration chosen, it is possible to position the hinge axis near or even at the centre of gravity of the sash including the pane.

[0025] The general principles underlying the invention are applicable to all kinds of hinges in which it is possible to provide a hinge axis which is offset from the hinge centre.

[0026] In one presently preferred embodiment, namely the first embodiment shown in Figs 2 to 6, the hinge 10 makes use of the operational principles common to one very well-proven type of hinge, viz. the pivot hinge including a guidance on the frame hinge part cooperating with a slide rail on the sash hinge part. Such pivot hinges are for instance disclosed in Applicant's EP 1 038 083 B1 and EP 1 781 883 B1, and are very versatile as regards operational areas and adaptation of components. Examples of roof windows incorporating such adapted hinges are shown in Applicant's published European patent applications EP 2 770 146 A1 and EP 2 770 149 A1. In the first embodiment of the present invention, the pivot hinge 10 is mounted in such a way that the concavity of the guidance and the slide rail faces the interior 8 of the roof window to provide the offset hinge axis α at a more interior position than the set of hinges 10. That is, the pivot hinge is mounted in a reverse or upside-down position relative to what is standard.

[0027] An alternative hinge is a pantograph hinge, in which the desired pattern of movements is provided by a linkage mechanism. The use of hinges including linkage mechanisms is traditionally most often known from the furniture field, but such hinges are also well-known to use for roof windows. Prior art examples include Danish patent No. 114 321, US patent No. 4,446,597, and Applicant's European patents EP 22 657 B1 and EP 89 813 B1. Such pantograph hinges also provide a hinge axis which is offset from the hinge centre. The same operation as described above and from here on is also true for the type of hinge described in the Applicant's interna-

tional application published under WO 2017/076416 A1. In another presently preferred embodiment, the second embodiment shown in Figs 7 to 10, the pantograph hinge 1010 defines a movement pattern providing the offset hinge axis α at a more interior position than the set of hinges 1010. This too entails a reverse or upside-down positioning of the hinge.

[0028] In the following, mounting of the hinge 10; 1010 to the roof window of the first and second embodiments will be described in further detail. Elements of the hinge in the second embodiment having the same or analogous function as counterpart elements of the hinge of the first embodiment are denoted by the same reference numerals to which 1000 has been added. The components of the window are denoted by the same reference numerals throughout the embodiments. Only differences between the two embodiments will be described in detail, wherever appropriate.

[0029] Referring in particular to Figs 5 and 6 for the first embodiment, and to Figs 9 and 10 for the second embodiment, the hinge 10; 1010 is connected to the frame 1 and the sash 2 by means of first mounting means and second mounting means. In both of the embodiments shown, the first mounting means comprises a first flange 140; 1140 in connection with the base plate 110; 1110 of the frame hinge part 100; 1100 and a second flange 150; 1150 in connection with the frame side member 11. The second mounting means comprises a first flange 240; 1240 in connection with the base plate 210; 1210 of the sash hinge part 200; 1200 and a second flange 250; 1250 in connection with the sash side member 21.

[0030] The connection between each first flange and the respective base plate may in principle be carried out in any suitable manner, but advantageously, and in the embodiments shown, the connection between the first flange 140, 240; 1140, 1240 and the respective base plate 110, 210; 1110, 1210 of the frame and sash hinge parts 100, 200; 1100, 1200 is integral.

[0031] In both of the embodiments, the respective base plate 110, 210; 1110, 1210 of the frame and sash hinge parts 100, 200; 1100, 1200 is substantially plane.

[0032] In the first embodiment, the first flange 140; 1140 of the first mounting means is substantially parallel to the plane of the base plate 110; 1110 of the frame hinge part 100; 1100.

[0033] This applies also to the first flange 1240 of the second mounting means in the second embodiment.

[0034] In the first embodiment, the first flange 240 forms an angle relative to the respective base plate 210. This allows the hinge 10 to be positioned more to the outwards.

[0035] The second flange 150; 1150 of the first mounting means in the first and second embodiments, and the second flange 1250 of the second mounting means of the second embodiment has an extension substantially parallel to the frame and sash plane, respectively. In the embodiments shown, the second flange 150; 1150 of the first mounted means is connected to a recess 11c in the

frame side member 11. Alternatively, these second flanges could alternatively be connected an exterior frame surface. The second flange 1250 of the second mounting means is connected to the exterior sash surface 21e of the sash side member. It is conceivable also to position this second flange 1250 in a recess.

[0036] In the first embodiment, the second flange 250 of the second mounting means has an extension substantially perpendicular to the sash plane and is connected to the outward sash surface 21b.

[0037] In the first embodiment, third mounting means are furthermore provided in addition to the first and second mounting means, said third mounting means here comprising a first flange 160 in connection with the base plate 110 of the frame hinge part 100, and a second flange 170 in connection with the frame side member 11. Corresponding further mounting means may also be present on the sash frame part.

[0038] It should be noted that the above description of preferred embodiments serves only as an example, and that a person skilled in the art will know that numerous variations are possible without deviating from the scope of the claims.

List of reference numerals

[0039]

1	frame	
	11 frame side member	
	11e exterior frame surface	
	11b inward frame surface	
	11c recess	
	11i interior frame surface	
2	sash	
21	sash side member	
21e	exterior sash surface	
21b	outward sash surface	
21i	interior sash surface	
3	pane	
7	exterior	
8	interior	
9	gap	
10	hinge	
	100 frame hinge part	
	110 baseplate	
	140 first flange of first mounting means	
	150 second flange of first mounting means	
	160 first flange of third mounting means	
	170 second flange of third mounting means	
	200 sash hinge part	
	210 baseplate	
	240 first flange of second mounting means	
	250 second flange of second mounting means	
1010	hinge	
	1100 frame hinge part	
	1110 base plate	
	1120 link	

		1140 first flange of first mounting means
		1150 second flange of first mounting means
		1200 sash hinge part
		1210 base plate
5		1240 first flange of second mounting means
		1250 second flange of second mounting means
	α	hinge axis
	c	hinge centre
	cf	circumference of base plate of frame hinge part
10	cs	circumference of base plate of sash hinge part

Claims

- 15 1. A roof window comprising:
- 20 a frame (1) with a plurality of frame members (11) defining a frame plane and adapted to be connected to a load-bearing structure of a roof of a building;
- 25 a sash (2) with a plurality of sash members (21) and carrying a pane (3) defining a sash plane; and
- 30 a set of hinges (10; 1010) connecting the sash (2) with the frame (1) to allow the sash plane to assume an angle relative to the frame plane, each hinge (10; 1010) of said set of hinges defining a hinge centre (c) and including a frame hinge part (100; 1100) in connection with a frame side member (11) and a sash hinge part (200; 1200) in connection with a sash side member (21) and configured to assume an angle relative to the frame hinge part (100; 1100), which frame hinge part (100; 1100) and sash hinge part (200; 1200) each comprise a base plate (110; 210), which are substantially plane and parallel to each other, said set of hinges (10; 1010) defining a hinge axis (α),
- 35 the sash (2) and frame (1) each having an interior side (21i, 11i) adapted to face the interior (8) of the building in the mounted condition and an exterior side (21e, 11e) adapted to face the exterior (7) of the building in the mounted condition, each base plate (110, 210; 1110, 1210) having a predefined circumference (cf, cs), the hinge centre (c) being defined as the geometrical centre of the predefined circumference (cs) of the base plate (210; 1210) of said sash hinge part (200; 1200),
- 40
- 45
- 50
- 55
- wherein the hinge centre (c) of each hinge (10; 1010) of said set of hinges is offset from the hinge axis (α), the hinge axis (α) is located to the interior of the exterior side (21e, 11e) of the sash (2) and frame (1), and the distance between the hinge axis (α) and the hinge centre (c) lies in the range of 30 to 150 mm, preferably 45 to 120 mm, more preferably 60 to 90

- mm, such that the hinge axis (α) is in the vicinity of the centre of gravity of the sash including the pane, **characterized in that** the set of hinges is arranged such that the hinge centre (c) of each hinge (10; 1010) is located to the exterior of the exterior side (21e, 11 e) of the sash (2) and frame (1).
2. A roof window according to claim 1, wherein the height of the base plate (110, 210; 1100, 1210) of the frame hinge part (100) and the sash hinge part (210), respectively, lies in the interval 40 to 80 mm, preferably 50 to 70 mm.
 3. A roof window according to any one of the preceding claims, wherein each hinge of said set of hinges comprises a pivot hinge (10) having a guidance on the frame hinge part (100) cooperating with a slide rail on the sash hinge part (200) and mounted in such a way that the concavity of the guidance and the slide rail faces the interior (8) of the roof window to provide the offset hinge axis (α) at a more interior position than the set of hinges (10).
 4. A roof window according to any one of claims 1 to 2, wherein each hinge of said set of hinges comprises a pantograph hinge (1010) having at least one link and defining a movement pattern providing the offset hinge axis (α) at a more interior position than the set of hinges (1010).
 5. A roof window according to any one of the preceding claims, wherein the hinge (10; 1010) is connected to the frame (1) and the sash (2) by means of first mounting means (140, 150; 1140, 1150) and second mounting means (240, 250; 1240, 1250).
 6. A roof window according to claim 5, wherein the first mounting means comprises a first flange (140; 1140) in connection with the base plate (110; 1110) of the frame hinge part (100; 1100) and a second flange (150; 1150) in connection with the frame side member (11), and the second mounting means comprises a first flange (240; 1240) in connection with the base plate (210; 1210) of the sash hinge part (200; 1200) and a second flange (250; 1250) in connection with the sash side member (21).
 7. A roof window according to claim 6, wherein the connection between the first flange (140, 240; 1140, 1240) and the respective base plate (110, 210; 1110, 1210) of the frame and sash hinge parts (100, 200; 1100, 1200) is integral.
 8. A roof window according to claim 6 or 7, wherein the first flange (140; 1140, 1240) is substantially parallel to the plane of the respective base plate (110, 210; 1110, 1210).
 9. A roof window according to claim 6 or 9, wherein first flange (240) forms an angle relative to the respective base plate (210).
 10. A roof window according to any one of claims 6 to 9, wherein the second flange (150; 1150, 1250) has an extension substantially parallel to the frame and sash plane, respectively.
 11. A roof window according to claim 10, wherein the second flange (150; 1150, 1250) is connected to an exterior frame surface or exterior sash surface (21e), or to a recess (11c) in the frame side member (11) or sash side member.
 12. A roof window according to any one of claims 6 to 9, wherein the second flange (250) has an extension substantially perpendicular to the frame and sash plane, respectively, and is connected to an inward frame surface or outward sash surface (21b).
 13. A roof window according to any one of claims 5 to 12, wherein third mounting means (160, 170) are provided in addition to the first and second mounting means, said third mounting means preferably comprising a first flange (160) in connection with the base plate (110) of the frame hinge part (100) or the sash hinge part, and a second flange (170) in connection with the frame side member (11) or the sash side member.

Patentansprüche

1. Dachfenster, umfassend:

einen Rahmen (1) mit mehreren Rahmenelementen (11), der eine Rahmenebene definiert und dazu ausgelegt ist, mit einer lasttragenden Struktur eines Dachs eines Gebäudes verbunden zu sein;

einen Flügel (2) mit mehreren Flügelementen (21), der eine Scheibe (3) trägt, die eine Flügelebene definiert; und

einen Satz von Scharnieren (10; 1010), die den Flügel (2) mit dem Rahmen (1) verbinden, um zu ermöglichen, dass die Flügelebene einen Winkel relativ zur Rahmenebene einnimmt, wobei jedes Scharnier (10; 1010) des Satzes von Scharnieren eine Scharniermitte (c) definiert und ein Rahmenscharnierteil (100; 1100), das mit einem Rahmenseitenelement (11) in Verbindung steht, sowie ein Flügelscharnierteil (200; 1200), das mit einem Flügelement (21) in Verbindung steht und dazu gestaltet ist, einen Winkel relativ zum Rahmenscharnierteil (100; 1100) einzunehmen, beinhaltet, wobei das Rahmenscharnierteil (100; 1100) und das Flügel-

- scharnierteil (200; 1200) jedes eine Grundplatte (110; 210) umfassen, die im Wesentlichen eben und parallel zueinander sind, wobei der Satz von Scharnieren (10; 1010) eine Scharnierachse (α) definiert,
- wobei der Flügel (2) und der Rahmen (1) jeder eine Innenseite (21i, 11i) aufweisen, die dazu ausgelegt ist, im montierten Zustand dem Inneren (8) des Gebäudes zugewandt zu sein, und eine Außenseite (21e, 11e), die dazu ausgelegt ist, im montierten Zustand dem Äußeren (7) des Gebäudes zugewandt zu sein,
- wobei jede Grundplatte (110, 210; 1110, 1210) einen vorbestimmten Umfang (cf, cs) aufweist, wobei die Scharniermitte (c) als die geometrische Mitte des vorbestimmten Umfangs (cs) der Grundplatte (210; 1210) des Flügelscharnierteils (200; 1200) definiert ist,
- wobei die Scharniermitte (c) jedes Scharniers (10; 1010) des Satzes von Scharnieren zur Scharnierachse (α) versetzt ist,
- die Scharnierachse (α) zum Inneren der Außenseite (21e, 11e) des Flügels (2) und des Rahmens (1) hin angeordnet ist,
- und der Abstand zwischen der Scharnierachse (α) und der Scharniermitte (c) im Bereich von 30 bis 150 mm, vorzugsweise 45 bis 120 mm, besonders vorzugsweise 60 bis 90 mm, liegt, sodass die Scharnierachse (α) in der Nähe des Schwerpunkts des die Scheibe beinhaltenden Flügels liegt,
- dadurch gekennzeichnet, dass** der Satz von Scharnieren so angeordnet ist, dass die Scharniermitte (c) jedes Scharniers (10; 1010) zum Äußeren der Außenseite (21e, 11e) des Flügels (2) und des Rahmens (1) hin angeordnet ist.
2. Dachfenster nach Anspruch 1, wobei die Höhe der Grundplatte (110, 210; 1100, 1210) des Rahmenscharnierteils (100) und des Flügelscharnierteils (210), jeweils im Bereich von 40 bis 80 mm, vorzugsweise 50 bis 70 mm liegt.
 3. Dachfenster nach einem der vorangehenden Ansprüche, wobei jedes Scharnier des Satzes von Scharnieren ein Drehscharnier (10) mit einer Führung am Rahmenscharnierteil (100) umfasst, das mit einer Gleitschiene am Flügelscharnierteil (200) zusammenwirkt und so montiert ist, dass die Konkavität der Führung und der Gleitschiene dem Inneren (8) des Dachfensters zugewandt ist, um die versetzte Scharnierachse (α) an einer Position bereitzustellen, die weiter innen liegt als der Satz von Scharnieren (10).
 4. Dachfenster nach einem der Ansprüche 1 bis 2, wobei jedes Scharnier des Satzes von Scharnieren ein Scherenscharnier (1010) umfasst, das zumindest eine Verbindung aufweist und ein Bewegungsmuster definiert, das die versetzte Scharnierachse (α) Position bereitstellt, die weiter innen liegt als der Satz von Scharnieren (1010).
 5. Dachfenster nach einem der vorangehenden Ansprüche, wobei das Scharnier (10; 1010) mit Hilfe eines ersten Befestigungsmittels (140, 150; 1140, 1150) und eines zweiten Befestigungsmittels (240, 250; 1240, 1250) am Rahmen (1) und am Flügel (2) befestigt ist.
 6. Dachfenster nach Anspruch 5, wobei das erste Befestigungsmittel einen mit der Grundplatte (110; 1110) des Rahmenscharnierteils (100; 1100) in Verbindung stehenden ersten Flansch (140; 1140) und einen mit dem Rahmenseitenelement (11) in Verbindung stehenden zweiten Flansch (150; 1150) umfasst und wobei das zweite Befestigungsmittel einen mit der Grundplatte (210; 1210) des Flügelscharnierteils (200; 1200) in Verbindung stehenden ersten Flansch (240; 1240) und einen mit dem Flügelseitenelement (21) in Verbindung stehenden zweiten Flansch (250; 1250) umfasst.
 7. Dachfenster nach Anspruch 6, wobei die Verbindung zwischen dem ersten Flansch (140, 240; 1140, 1240) und der jeweiligen Grundplatte (110, 210; 1110, 1210) des Rahmens und der Flügelscharnierteile (100, 200; 1100, 1200) stoffschlüssig ist.
 8. Dachfenster nach Anspruch 6 oder 7, wobei der erste Flansch (140; 1140, 1240) im Wesentlichen parallel zur Ebene der jeweiligen Grundplatte (110, 210; 1110, 1210) ist.
 9. Dachfenster nach Anspruch 6 oder 9, wobei der erste Flansch (240) einen Winkel relativ zur jeweiligen Grundplatte (210) ausbildet.
 10. Dachfenster nach einem der Ansprüche 6 bis 9, wobei der zweite Flansch (150; 1150, 1250) eine Erstreckung aufweist, die im Wesentlichen parallel zur Rahmen- bzw. Flügelebene ist.
 11. Dachfenster nach Anspruch 10, wobei der zweite Flansch (150; 1150, 1250) mit einer äußeren Rahmenfläche bzw. äußeren Flügelfläche (21e) oder mit einer Ausnehmung (11c) im Rahmenseitenelement (11) bzw. im Flügelseitenelement verbunden ist.
 12. Dachfenster nach einem der Ansprüche 6 bis 9, wobei der zweite Flansch (250) eine Erstreckung aufweist, die im Wesentlichen parallel zur Rahmen- bzw. Flügelebene ist und mit einer inneren Rahmenfläche oder äußeren Flügelfläche (21b) verbunden ist.

13. Dachfenster nach einem der Ansprüche 5 bis 12, wobei zusätzlich zum ersten und zweiten Befestigungsmittel ein drittes Befestigungsmittel (160, 170) bereitgestellt ist, wobei das Befestigungsmittel vorzugsweise einen mit der Grundplatte (110) des Rahmenscharnierteils (100) bzw. des Flügelscharnierteils in Verbindung stehenden ersten Flansch (160) und einen mit dem Rahmenseitenelement (11) bzw. dem Flügelseitenelement in Verbindung stehenden zweiten Flansch (170) umfasst.

Revendications

1. Fenêtre de toit comprenant:

un cadre (1) avec une pluralité d'éléments de cadre (11) définissant un plan de cadre et adaptés pour être reliés à une structure porteuse d'un toit d'un bâtiment;

un châssis (2) avec une pluralité d'éléments de châssis (21) et portant une vitre (3) définissant un plan de châssis; et

un ensemble de charnières (10; 1010) reliant le châssis (2) au cadre (1) pour permettre au plan du châssis de prendre un angle par rapport au plan du cadre, chaque charnière (10; 1010) dudit ensemble de charnières définissant un centre de charnière (c) et comprenant une partie charnière de cadre (100; 1100) en liaison avec un élément latéral du cadre (11) et une partie charnière de châssis (200; 1200) en liaison avec un élément latéral de châssis (21) et configuré pour prendre un angle par rapport à la partie charnière de châssis (100; 1100), ladite partie charnière de cadre (100; 1100) et ladite partie charnière de châssis (200; 1200) comprennent chacune une plaque de base (110; 210), qui sont sensiblement planes et parallèles entre elles, ledit ensemble de charnières (10; 1010) définissant un axe d'articulation (α),

le châssis (2) et le cadre (1) ayant chacun un côté intérieur (21i, 11i) adapté pour faire face à l'intérieur (8) du bâtiment à l'état monté et un côté extérieur (21e, 11e) adapté pour faire face à l'extérieur (7) du bâtiment à l'état monté, chaque plaque de base (110, 210; 1110, 1210) ayant une circonférence prédéfinie (cf, cs), le centre de charnière (c) étant défini comme le centre géométrique de la circonférence prédéfinie (cs) de la plaque de base (210; 1210) de ladite partie charnière de châssis (200; 1200), dans laquelle

le centre de charnière (c) de chaque charnière (10; 1010) dudit ensemble de charnières est décalé de l'axe de charnière (α),

l'axe de charnière (a) est situé à l'intérieur du côté extérieur (21e, 11e) du châssis (2) et du

cadre (1),

et la distance entre l'axe de charnière (α) et le centre de charnière (c) est comprise entre 30 et 150 mm, de préférence entre 45 et 120 mm, plus préférablement entre 60 et 90 mm, de sorte que l'axe de charnière (α) se trouve à proximité du centre de gravité du châssis, vitre comprise, **caractérisée en ce que**

l'ensemble de charnières est disposé de telle sorte que le centre de charnière (c) de chaque charnière (10; 1010) est situé à l'extérieur du côté extérieur (21e, 11e) du châssis (2) et du cadre (1).

2. Fenêtre de toit selon la revendication 1, dans laquelle la hauteur de la plaque de base (110, 210; 1100, 1210) de la partie charnière de cadre (100) et de la partie charnière de châssis (210) se situe respectivement dans l'intervalle de 40 à 80 mm, de préférence de 50 à 70 mm.

3. Fenêtre de toit selon l'une quelconque des revendications précédentes, dans laquelle chaque charnière dudit ensemble de charnières comprend une charnière pivotante (10) ayant un guidage sur la partie charnière de cadre (100) coopérant avec un rail coulissant sur la partie charnière de châssis (200) et montée de telle manière que la concavité du guidage et du rail coulissant soit tournée vers l'intérieur (8) de la fenêtre de toit pour fournir l'axe de charnière décalé (α) dans une position plus intérieure que l'ensemble des charnières (10).

4. Fenêtre de toit selon l'une quelconque des revendications 1 à 2, dans laquelle chaque charnière dudit ensemble de charnières comprend une charnière pantographe (1010) ayant au moins une liaison et définissant une séquence de mouvement fournissant l'axe de charnière décalé (α) dans une position plus intérieure que l'ensemble des charnières (1010).

5. Fenêtre de toit selon l'une quelconque des revendications précédentes, dans laquelle la charnière (10; 1010) est reliée au cadre (1) et au châssis (2) au moyen de premiers moyens de montage (140, 150; 1140, 1150) et de deuxièmes moyens de montage (240, 250; 1240, 1250).

6. Fenêtre de toit selon la revendication 5, dans laquelle le premier moyen de montage comprend une première bride (140; 1140) en liaison avec la plaque de base (110; 1110) de la partie charnière de cadre (100; 1100) et une seconde bride (150; 1150) en liaison avec l'élément latéral de cadre (11), et le deuxième moyen de montage comprend une première bride (240; 1240) en liaison avec la plaque de base (210; 1210) de la partie charnière de châssis

(200; 1200) et une seconde bride (250; 1250) en liaison avec l'élément latéral de châssis (21).

7. Fenêtre de toit selon la revendication 6, **caractérisée en ce que** la liaison entre la première bride (140, 240; 1140, 1240) et la plaque de base respective (110, 210; 1110, 1210) des parties charnière de cadre et de châssis (100, 200; 1100, 1200) est solidaire. 5
8. Fenêtre de toit selon la revendication 6 ou 7, dans laquelle la première bride (140; 1140, 1240) est sensiblement parallèle au plan de la plaque de base respective (110, 210; 1110, 1210). 10
9. Fenêtre de toit selon la revendication 6 ou 9, dans laquelle la première bride (240) forme un angle par rapport à la plaque de base respective (210). 15
10. Fenêtre de toit selon l'une quelconque des revendications 6 à 9, dans laquelle la seconde bride (150; 1150, 1250) a une extension sensiblement parallèle au plan du cadre et du châssis, respectivement. 20
11. Fenêtre de toit selon la revendication 10, dans laquelle la seconde bride (150; 1150, 1250) est reliée à une surface extérieure de cadre ou à une surface extérieure de châssis (21e), ou à un évidement (11c) dans l'élément latéral de cadre (11) ou l'élément latéral de châssis. 25
12. Fenêtre de toit selon l'une quelconque des revendications 6 à 9, dans laquelle la seconde bride (250) a une extension sensiblement perpendiculaire au plan du cadre et du châssis, respectivement, et est reliée à une surface intérieure du cadre ou à une surface extérieure du châssis (21b). 30
13. Fenêtre de toit selon l'une quelconque des revendications 5 à 12, dans laquelle des troisièmes moyens de montage (160, 170) sont prévus en plus des premiers et deuxièmes moyens de montage, lesdits troisièmes moyens de montage comprenant de préférence une première bride (160) en liaison avec la plaque de base (110) de la partie charnière de cadre (100) ou la partie charnière de châssis, et une seconde bride (170) en liaison avec l'élément latéral de cadre (11) ou l'élément latéral de châssis. 35

40

45

50

55

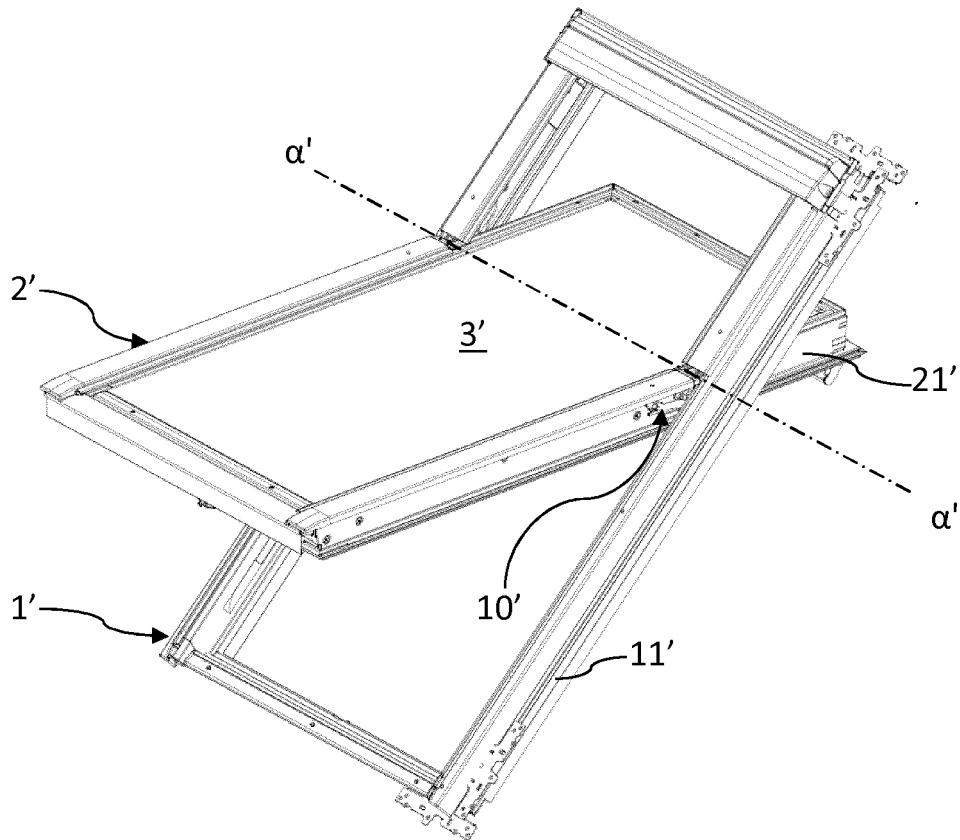

Fig. 1 (PRIOR ART)

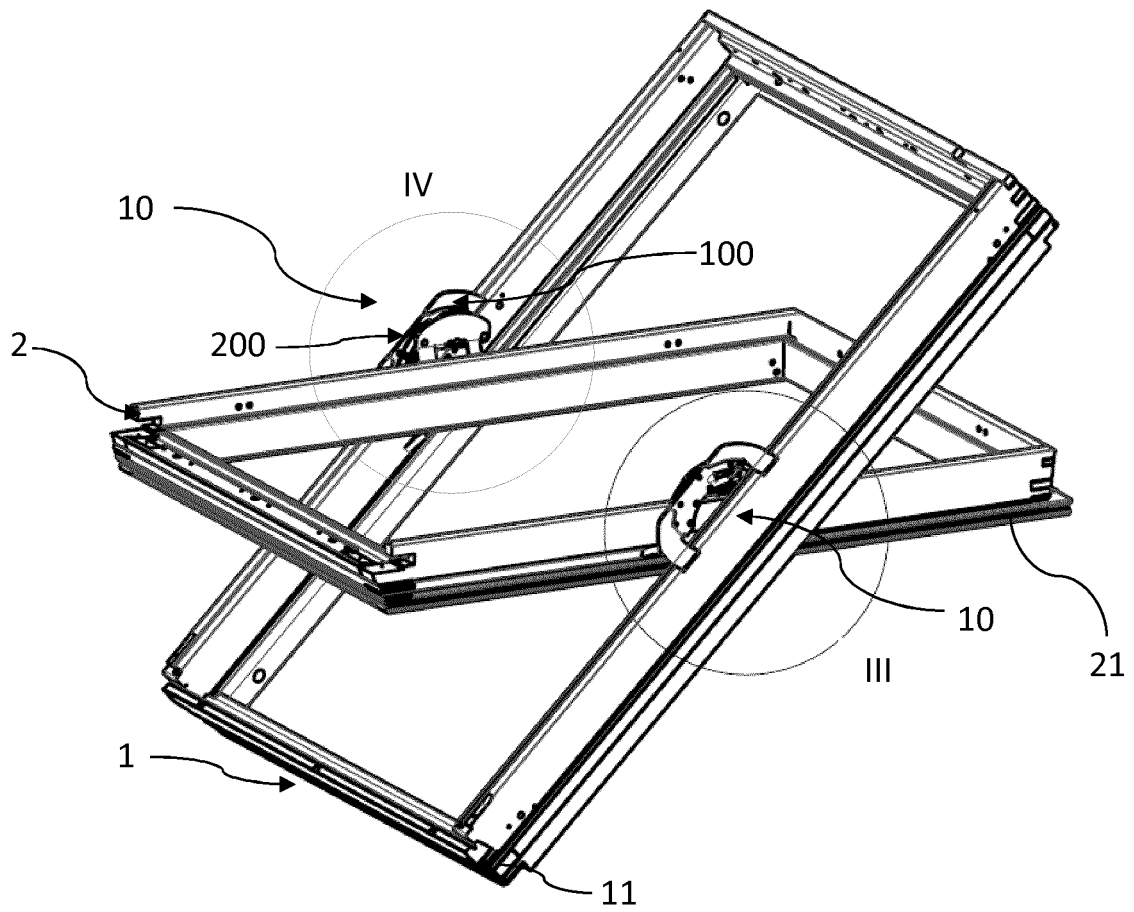

Fig. 2

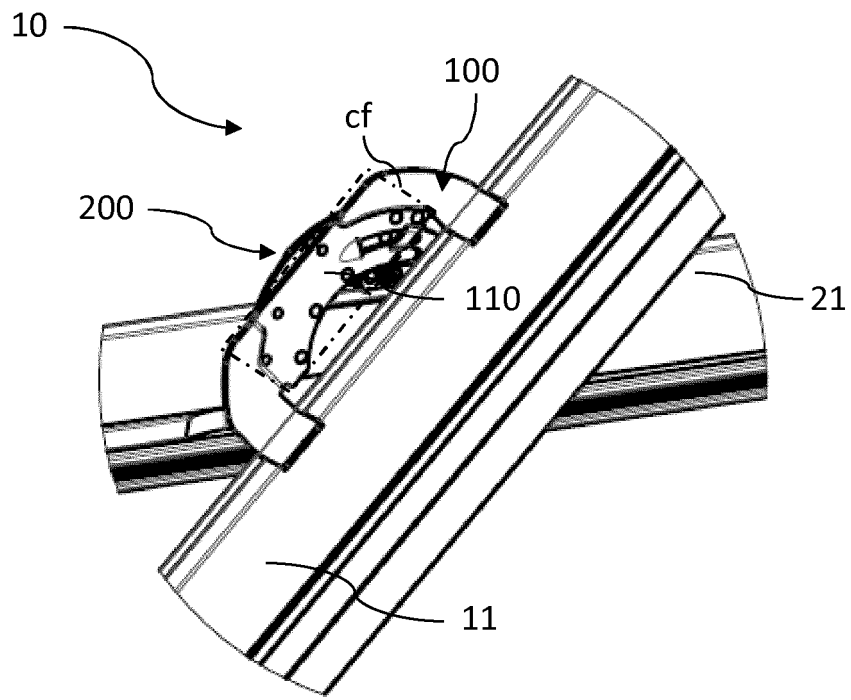

Fig. 3

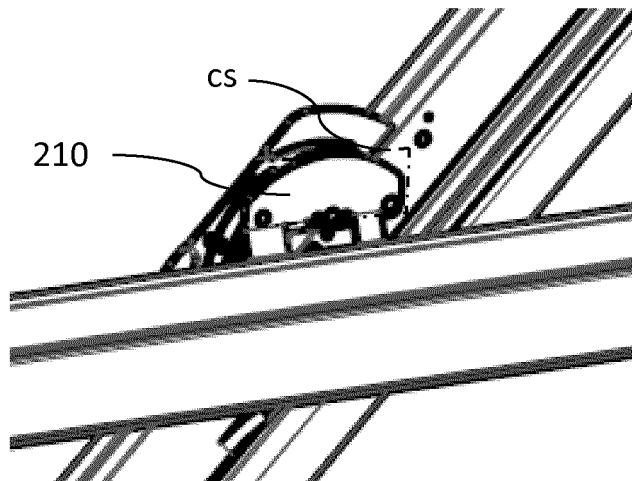

Fig. 4

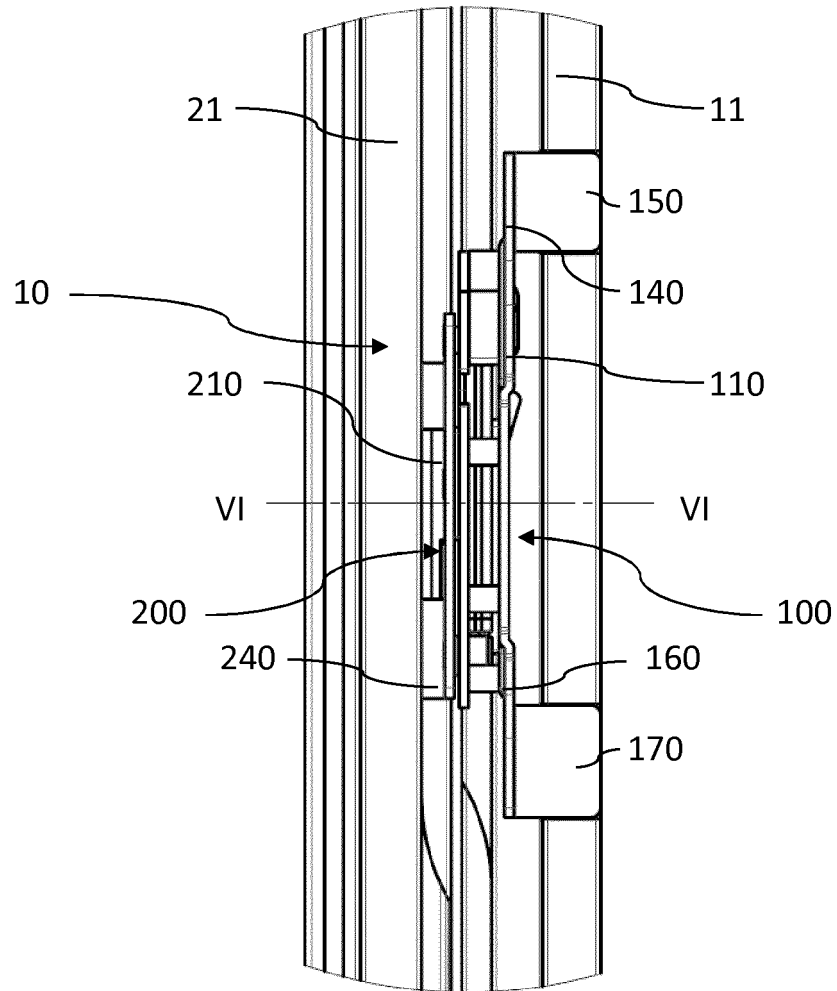

Fig. 5

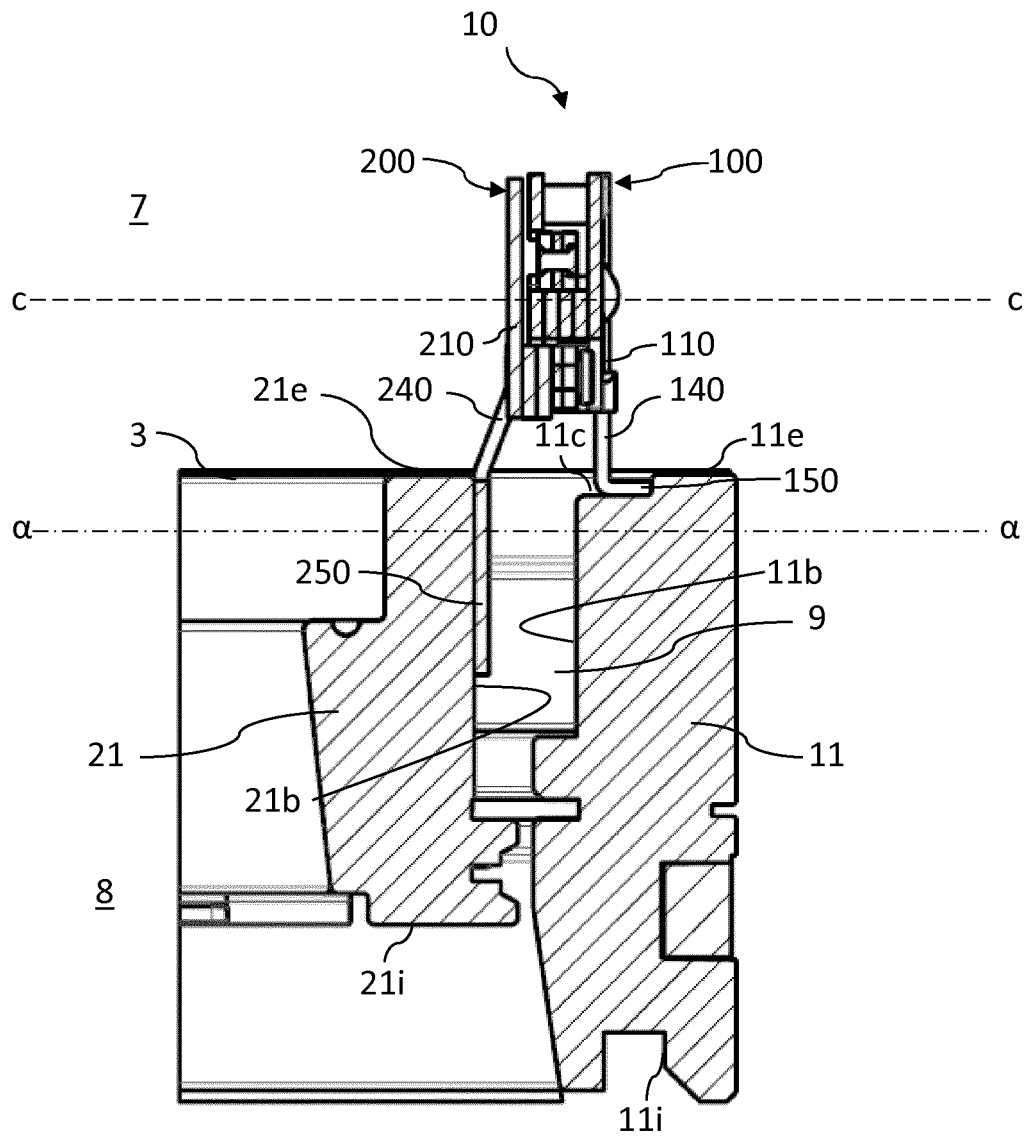

Fig. 6

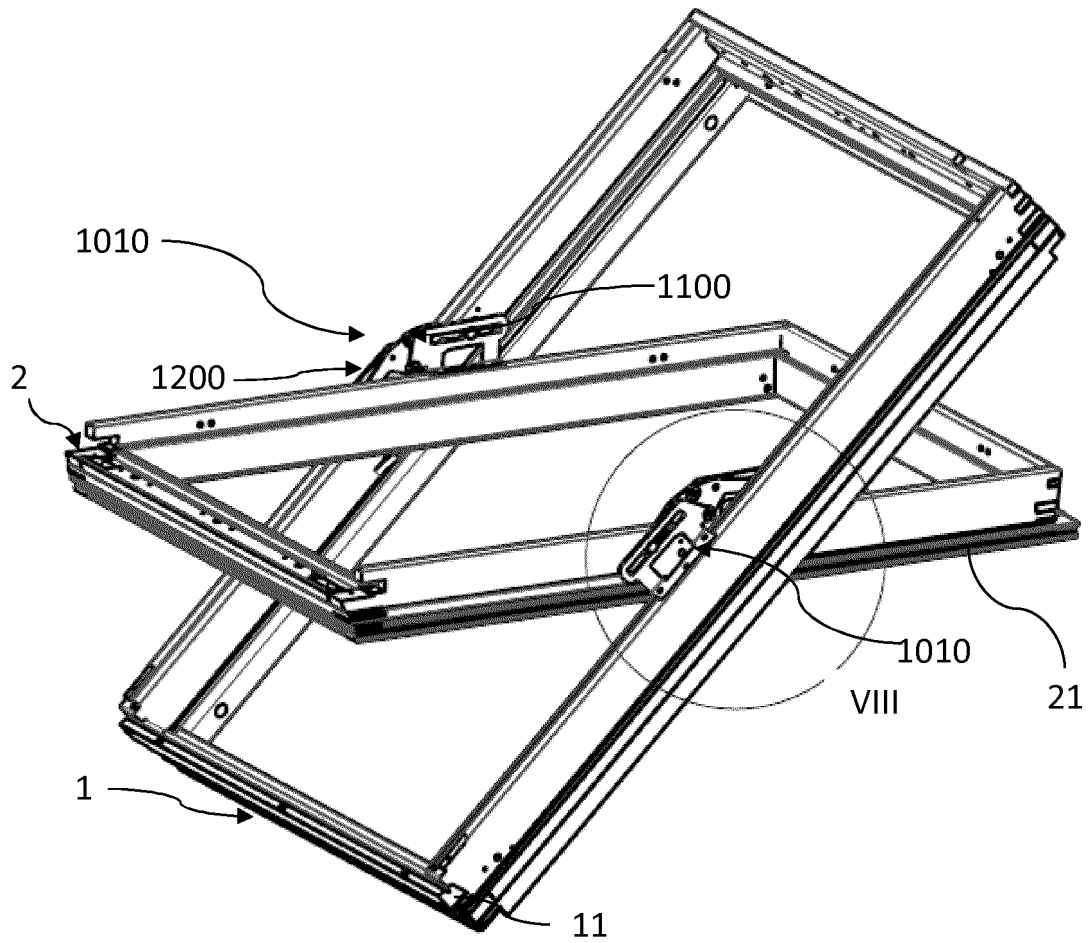

Fig. 7

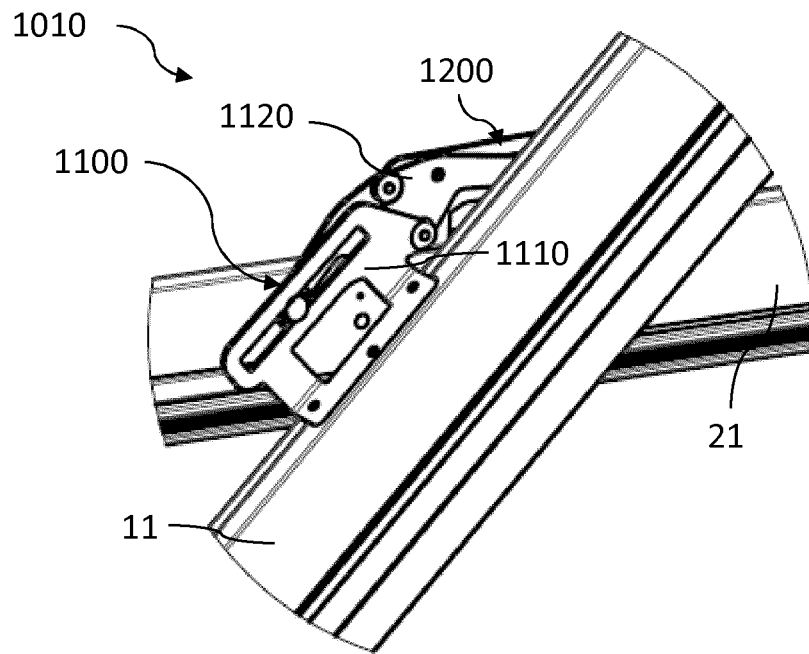

Fig. 8

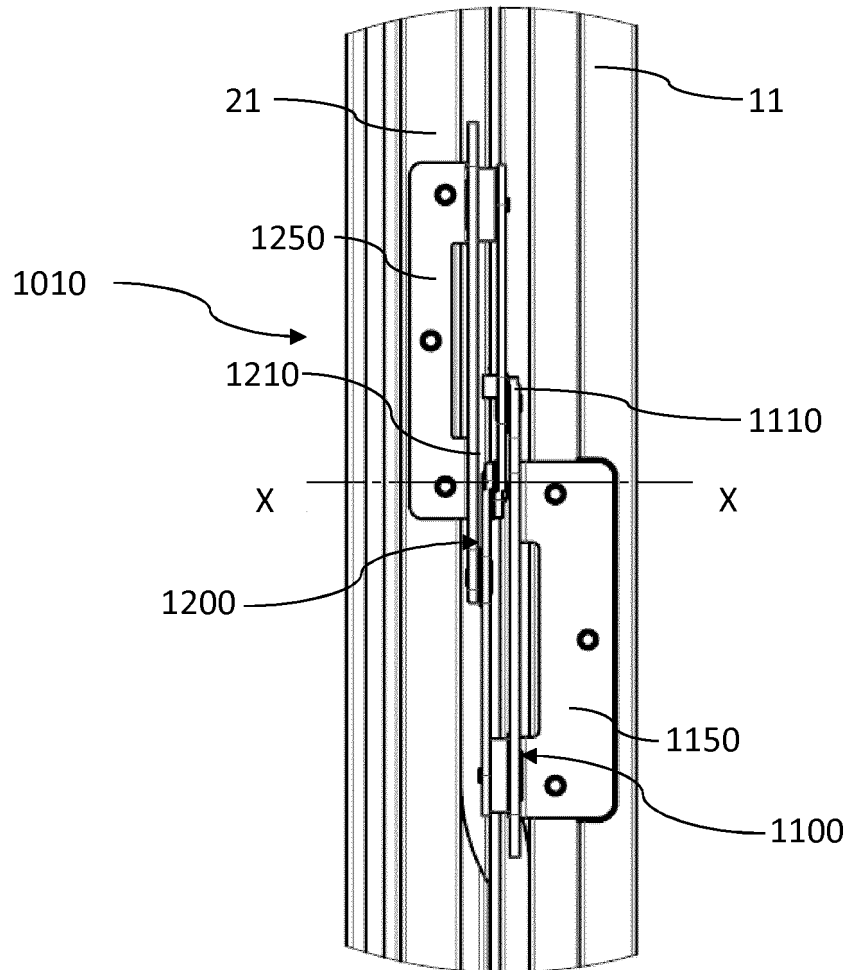

Fig. 9

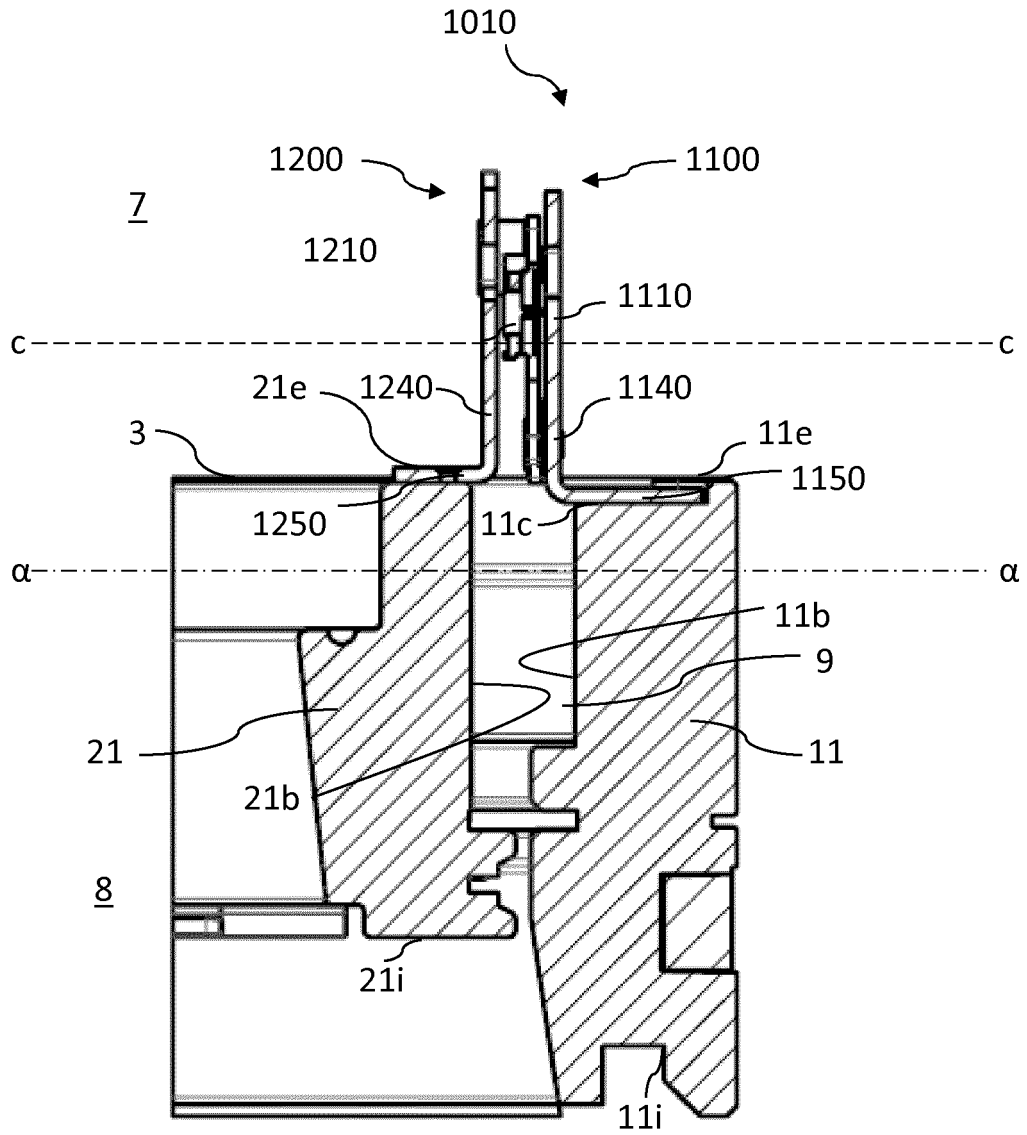

Fig. 10

REFERENCES CITED IN THE DESCRIPTION

This list of references cited by the applicant is for the reader's convenience only. It does not form part of the European patent document. Even though great care has been taken in compiling the references, errors or omissions cannot be excluded and the EPO disclaims all liability in this regard.

Patent documents cited in the description

- US 2885745 A [0004]
- EP 2770146 A [0004]
- EP 2770149 A [0004]
- EP 2770146 A1 [0011] [0026]
- EP 2770149 A1 [0011] [0026]
- EP 1038083 B1 [0026]
- EP 1781883 B1 [0026]
- DK 114321 [0027]
- US 4446597 A [0027]
- EP 22657 B1 [0027]
- EP 89813 B1 [0027]
- WO 2017076416 A1 [0027]