

⑫ **EUROPEAN PATENT SPECIFICATION**

④⑤ Date of publication of patent specification: **27.12.85**

⑤① Int. Cl.⁴: **G 11 C 27/02**

②① Application number: **81302611.9**

②② Date of filing: **11.06.81**

⑤④ **Sampled signal generation circuit.**

③⑩ Priority: **20.06.80 JP 83830/80**
20.06.80 JP 83831/80
20.11.80 JP 163912/80
20.11.80 JP 163916/80

④③ Date of publication of application:
13.01.82 Bulletin 82/02

④⑤ Publication of the grant of the patent:
27.12.85 Bulletin 85/52

④④ Designated Contracting States:
DE FR GB IT NL

⑤③ References cited:
DE-A-2 412 382
US-A-3 753 133
US-A-3 864 639

⑦③ Proprietor: **Kabushiki Kaisha Toshiba**
72, Horikawa-cho Saiwai-ku
Kawasaki-shi Kanagawa-ken 210 (JP)

⑦② Inventor: **Kitagawa, Kazuo**
1604-13, Ida
Nakahara-ku Kawasaki-shi (JP)
Inventor: **Endoh, Kenjiro**
C-403 Sakuradai-dwelling 30-9, Sakuradai
Midori-ku Yokohama-shi (JP)
Inventor: **Kira, Hideshi**
Toshiba-Hiyoshi-ryo 1020 Hiyoshi-Honcho
Kohoku-ku Yokohama-shi (JP)

⑦④ Representative: **Freed, Arthur Woolf et al**
MARKS & CLERK 57-60 Lincoln's Inn Fields
London WC2A 3LS (GB)

Note: Within nine months from the publication of the mention of the grant of the European patent, any person may give notice to the European Patent Office of opposition to the European patent granted. Notice of opposition shall be filed in a written reasoned statement. It shall not be deemed to have been filed until the opposition fee has been paid. (Art. 99(1) European patent convention).

Description

This invention relates to a sampled signal generation circuit used in an analog-digital conversion device or the like.

In converting an analog signal into a digital signal by means of an analog-digital (A/D) converter, or in modulating an analog signal on the basis of the delta modulation, the input analog signal is sampled at a constant frequency. In a well-known sampling circuit, when, for example, an analog signal as shown in Fig. 1A is sampled in response to sampling pulses as shown in Fig. 1B a sampled signal as shown in Fig. 1C may be obtained. Similarly, when an analog signal of Fig. 1A is applied to an encoder for delta modulation, a delta modulated signal as shown in Fig. 1D is delivered from the encoder.

As is apparent from Fig. 1C, the variation of the analog input signal at each individual sampling interval is greater in a region where the rate of change of the input signal is high than in a region where the rate of change is low. Therefore, it is not correct to say that the sampled signal shown in Fig. 1C corresponds to the analog input signal shown in Fig. 1A with high fidelity. As is evident from Fig. 1D, moreover, the delta modulated signal obtained on the basis of the sampled signal shown in Fig. 1C will cause overslope distortion where the rate of change of the analog input signal is high.

US—A—3 753 133 discloses a sampled signal generation circuit having signal generating means and data generating means for successively producing data in response to an output signal from the signal generating means. The signal generating means produces an output signal variable in accordance with a control signal. The sampled data generation circuit also includes control means for detecting the difference between the input and the output of the data generating means and supplies to the signal generating means an output signal corresponding to that difference as said control signal. In this way, the signal generating means is controlled to increase or decrease the frequency of the output signal from the signal generating means as that difference becomes larger or smaller.

An object of this invention is to provide a sampled signal generation circuit capable of producing a sampled signal corresponding to an analog input signal with high fidelity.

According to one aspect of this invention, there is provided a sampled signal generation circuit comprising signal generating means, data generating means for successively sampling data in response to an output signal from said signal generating means, said signal generating means producing an output signal at a frequency variable according to a control signal, and control means for detecting the difference between two data sampled by said data generating means and supplying to said signal generating means an output signal corresponding to said difference as

said control signal, thereby controlling said signal generating means to increase or decrease the frequency of the output signal from said signal generating means according as said difference becomes larger or smaller, the frequency of said output signal from said signal generating means having a minimum positive value.

According to another aspect of this invention, there is provided a sampled signal generation circuit comprising signal generating means, data generating means for successively sampling data corresponding to an analog input signal in response to an output signal from said signal generating means, said signal generating means producing an output signal at a frequency variable according to a control signal, and control means for supplying to said signal generating means an output signal as said control signal corresponding to the gradient of the analog input signal, thereby controlling said signal generating means to increase or decrease the frequency of the output signal from said signal generating means according as said gradient becomes larger or smaller, the frequency of said output signal from said signal generating means having a minimum positive value.

In US—A—3 753 133, when an analog input signal is increased or decreased by a specified value in respect to the previously sampled signal level, the next sampling pulse is generated. More specifically, the sampling frequency is varied in response to the timing of the specified increase or decrease of the input signal over or under the signal level of the previous sample. Accordingly, when variation in the input signal is smaller than the specified value, the sampling operation is not performed.

According to this invention, a clock signal with higher sampling frequency is used in a case where the rate of change of the analog input signal is high, as compared with a case where the rate of change is low, so that a sampled signal representing the analog input signal with high fidelity can be obtained irrespective of the variation in the rate of change of the analog input signal.

This invention can be more fully understood from the following detailed description when taken in conjunction with the accompanying drawings, in which:

Figs. 1A to 1D show signal waveforms for illustrating the operation of a prior art sampling circuit;

Figs. 2A to 2D show signal waveforms for illustrating the operation of a sampled signal generation circuit according to this invention;

Fig. 3 is a block diagram of a sampled signal generation circuit according to an embodiment of the invention;

Fig. 4 is a detailed block diagram of a control circuit used in the sampled signal generation circuit shown in Fig. 3;

Fig. 5 is a circuit diagram of a voltage controlled oscillator used in the sampled signal generation circuit shown in Fig. 3;

Figs. 6A to 6E show signal waveforms for illustrating the operation of the sampled signal generation circuit shown in Figs. 3 to 5;

Fig. 7 is a circuit diagram of an A/D converting circuit according to another embodiment of the invention;

Fig. 8 is a circuit diagram of an analog signal storing circuit according to still another embodiment of the invention;

Fig. 9 is a block diagram of a sampled signal generation circuit according to a further embodiment of the invention;

Fig. 10 is a detailed block diagram of a control circuit used in the sampled signal generation circuit shown in Fig. 9;

Fig. 11 shows an input-output characteristic curve of a nonlinear circuit used in the control circuit shown in Fig. 10;

Fig. 12 shows another example of the control circuit used in the sampled signal generation circuit shown in Fig. 9;

Fig. 13 is a circuit diagram of an A/D converting circuit according to another embodiment of the invention;

Fig. 14 is a circuit diagram of an analog signal storing circuit according to still another embodiment of the invention;

Fig. 15 is a block diagram of a sampled data generation circuit according to a further embodiment of the invention;

Fig. 16 is a circuit diagram of a voltage controlled oscillator capable of being substituted for the one shown in Fig. 5;

Fig. 17 is a connection diagram for illustrating the connection between the A/D converting circuit shown in Fig. 7 or 13 and a D/A converter combined with the A/D converting circuit to form a data transmission circuit; and

Fig. 18 shows a modification of the analog signal storing circuit shown in Fig. 8.

Referring first to Figs. 2A to 2D, the principle of this invention will be described.

In a sampled signal generation circuit according to this invention, a sampled signal as shown in Fig. 2C may, for example, be obtained by sampling an analog signal as shown in Fig. 2A in response to sampling pulses whose frequency increases with the increase of the rate of change of the analog input signal, as shown in Fig. 2B. That is, in the sampled signal generation circuit of the invention, sampling is executed not at regular intervals along the time base of the input signal, but in accordance with the rate of change of the analog input signal. In a first sampling method, for example, the sampling timing is determined by the difference between two preceding sampled data obtained consecutively, and the greater the difference between the two sampled data, the shorter the sampling interval will be. These sampled data are stored in a memory directly or after they are converted into digital data by an A/D converter. In this case, the sampled data stored in the memory contain no time base information, so that it is essential to give time base information to the sampled data read out from the memory. This

requirement may, for example, be fulfilled as follows.

If sampled data $SD(t_{i-1})$ and $SD(t_i)$ are obtained at sampling timings t_{i-1} and t_i respectively, the next sampling timing t_{i+1} depends on the difference ΔSD between these sampled data $SD(t_{i-1})$ and $SD(t_i)$. In other words, the interval τ_i between the sampling timings t_i and t_{i+1} is primarily determined by the difference ΔSD , and can be restored if a sampled data $SD(t_0)$ at a sampling timing t_0 and the initial sampling interval τ_0 are given. For example, the sampling interval τ_i is given by the following equations:

$$\tau_i = \tau_{\max} - a\Delta SD \quad (1)$$

$$\tau_i = \tau_{\min} + \frac{c}{\Delta SD + b} \quad (2)$$

Here, a , b and c are constants, τ_{\max} and τ_{\min} are the maximum and minimum values of τ_i , respectively.

Thus, the following sampled data is read out from the memory after a time interval corresponding to the difference between the two preceding sampled data, and in the end these sampled data are read out with information on the same sampling timing as encoding.

In a second sampling method, a subsequent sampling timing is determined by, for example, a gradient data $|dg(t)/dt|$ on the gradient of the analog input signal at the preceding sampling timing, and the greater the value of the gradient data, the shorter the sampling interval will be. For example, the sampling frequency $f(t)$ is given by the following equation:

$$f(t) = a|dg(t)/dt| + b \quad (3)$$

where a and b are constants.

Assuming that the value of a gradient data is substantially constant during the interval τ_i , then, the difference ΔSD_i between the two sampled data is given by the following equation;

$$|\Delta SD_i| = |dg(t_i)/dt_i| \times \tau_i \quad (4)$$

From eqs. (3) and (4), a sampling frequency $f(t_i)$ ($=1/\tau_i$) at the sampling timing t_i is given by the following equation:

$$f(t_i) = b / (1 - a|\Delta SD_i|) \quad (5)$$

Thus, the sampling frequency can be primarily determined by the two successive sampled data, so that information on the sampling timing for the next sampled data can be obtained from the difference between the two sampled data successively read out from the memory.

On the basis of the above-mentioned principle, the analog input signal can be sampled in response to sampling pulses with controlled frequency, and the sampled data thus obtained can be read out with information on the sampling timing after they are once stored in the memory.

Now there will be described several embodiments of the sampled signal generation circuit of this invention with reference to the accompanying drawings.

Fig. 3 shows an embodiment of the sampled signal generation circuit of the invention which includes a sample and hold circuit 10 for sampling and holding an analog input signal, a voltage controlled oscillator (VCO) 12 for supplying the sample and hold circuit 10 with sampling pulses, and a control circuit 14 for controlling the frequency of the sampling pulses from the VCO 12 in accordance with the sampled signal from the sample and hold circuit 10. As shown in Fig. 4, for example, the control circuit 14 controls the VCO 12 in accordance with the difference between two sampled data successively generated from the sample and hold circuit 10. The control circuit 14 shown in Fig. 4 includes a sample and hold circuit 16 for sampling and holding an output signal from the sample and hold circuit 10 in response to clock pulses CP1 which are generated from a clock pulse generator 18 with a predetermined time delay with respect to the sampling pulses from the VCO 12, an adder 20 for producing an output signal corresponding to the difference between output signals from the sample and hold circuits 10 and 16, and a sample and hold circuit 22 for sampling and holding a signal transmitted from the adder 20 through an absolute value circuit 24 in response to clock pulses CP2 which are generated from the clock pulse generator 18 with a slight time delay with respect to the sampling pulses from the VCO 12. An output signal from the sample and hold circuit 22 is multiplied in a multiplier 26 by a negative-value coefficient data K generated from a coefficient generator 28, the product is added by the adder 30 to a reference voltage V_{REF} delivered from a reference value generator 32, and the sum is supplied to the control terminal of the VCO 12.

Fig. 5 shows an example of the arrangement of the VCO 12. The VCO 12 includes a voltage divider 40 connected between a power source terminal $+V_D$ and the ground through a resistor, an integration circuit 42 for integrating output voltages from the voltage divider 40, and a comparing circuit 44 for comparing output signals from the integration circuit 42 and a polarity switching circuit 46. The output terminal of the comparing circuit 44 is connected to the voltage divider 40, the polarity switching circuit 46, and a pulse generator 48. The comparing circuit 44 produces an output voltage $+V_D$ when it detects that the output signal of the integration circuit 42 is higher than the output signal of the polarity switching circuit 46, and produces an output voltage $-V_D$ when the reverse is the case. The polarity switching circuit 46 inverts the polarity of a control voltage from the control circuit 14 (Fig. 3) to supply the comparing circuit 44 with an inverted voltage when the output signal of the comparing circuit 44 is positive.

Assume now that, in this VCO 12, the comparing circuit 44 is producing the output

voltage $+V_D$. In this case, the integration circuit 42 integrates an output voltage V_I from the voltage divider 40 to produce an output signal which is reduced with the passage of time t at the rate of

$$5 \quad \frac{V_I}{RC} - t$$

(R and C are values of resistor and capacitor in time constant circuit of the integration circuit 42 respectively). As for the polarity switching circuit 46, it inverts an output voltage V_C from the control circuit 14 to supply the comparing circuit 44 with an output voltage $-V_C$. When the output voltage from the integration circuit 42 becomes lower than the voltage $-V_C$, the comparing circuit 44 produces an output voltage $-V_D$. As a result, the integration circuit 42 produces an output signal which rises with time at the rate of

$$10 \quad \frac{V_I}{RC} + t$$

In this case, a negative voltage is generated from the comparing circuit 44, so that the polarity switching circuit 46 supplies the comparing circuit 44 directly with the output voltage V_C from the control circuit 14 without inverting the same. When the output voltage of the integration circuit 42 rises and exceeds the voltage V_C , the comparing circuit 44 produces an output voltage $+V_D$. Thus, the output voltage $+V_D$ and $-V_D$ are alternately generated from the comparing circuit 44, this period of time being proportional to V_C , and given by equation

$$15 \quad \frac{V_C}{2RC} - \frac{V_I}{V_I}$$

and the pulse generator 48 produces output pulses in response to the output voltage from the comparing circuit 44 at the level change of the output voltage. In consequence, the lower the output voltage from the control circuit 14, that is, the greater the difference between two successive sampled data, the higher the pulse rate at which the output pulses are generated from the pulse generator 48 will be.

Referring now to Figs. 6A to 6E, there will be described the operation of the sampled signal generation circuit shown in Figs. 3 to 5.

Suppose now that an output signal as shown in Fig. 6A is generated from the sample and hold circuit 10. The output signal of Fig. 6A is sampled by the sample and hold circuit 16 in accordance with the clock pulses CP1 from the clock pulse generator 18, and an output signal as shown in Fig. 6B is generated from the sample and hold circuit 16. The difference between the output signals from these sample and hold circuits 10 and 16 is calculated by the adder 20, and an output signal as shown in Fig. 6C is generated

from the adder 20. The output signal from the adder 20 is converted by the absolute value circuit 24 into a signal with, for example, positive polarity as shown in Fig. 6D, and then sampled by the sample and hold circuit 22 in accordance with the clock pulses CP2 from the clock pulse generator 18. Thus, an output signal from the sample and hold circuit 22 represents the difference between the two successive sampled signals from the sample and hold circuit 10 as shown in Fig. 6E.

The output signal ΔSD_i from the sample and hold circuit 22 is multiplied by the coefficient K on the multiplier 26, and the product is added to the reference voltage V_{REF} in the adder 30. As a result, an output signal $(V_{REF} + K \cdot \Delta SD_i)$ is generated from the adder 30. The output signal from the adder 30 is applied as a control voltage V_C to the VCO 12. Since K is set to a negative value, the value of the control voltage V_C decreases as the value of the output signal ΔSD_i from the sample and hold circuit 22 increases, and the lower the control voltage V_C , the higher the pulse rate at which the output pulses are generated from the VCO 12 will be. Thus, the sample and hold circuit 10 samples and holds the analog input signal at shorter sampling intervals.

Fig. 7 shows an A/D converting circuit utilizing the sampled signal generation circuit shown in Fig. 3. The A/D converting circuit includes a comparator 50 with a first input terminal coupled to the output terminal of the sample and hold circuit 10, a counter 52 for counting high-frequency clock pulses from a clock pulse generator 54, and a local D/A converter 56 for converting output count data from the counter 52 into an analog signal to supply a second input terminal of the comparator 50 with the analog signal. The output terminal of the D/A converter 56 is coupled to the control circuit 14.

A pulse generator 58 supplies to an AND gate 60 output pulses with predetermined pulse width in response to the output pulses from the VCO 12, thereby controlling the AND gate 60. The AND gate 60 is controlled also by the comparator 50 which produces a high-level output signal when it detects that the output signal from the sample and hold circuit 10 is higher than the output signal from the D/A converter 56. Namely, the AND gate 60 allows the clock pulses from the clock pulse generator 54 to be supplied to the counter 52 only while both the comparator 50 and the pulse generator 58 are producing high-level signals. The output data of the counter 52 is set into a register 62 when the trailing edge of the output pulse from the pulse generator 58 is produced, and thereafter the counter 52 is cleared in response to the leading edge of an output pulse from the comparator 50.

Now there will be described the operation of the A/D converting circuit shown in Fig. 7.

When a sampling pulse is generated from the VCO 12, the sample and hold circuit 10 samples and holds an analog input signal to supply an output signal to the comparator 50, thereby

causing a high-level output signal to be generated from the comparator 50. At this time, the pulse generator 58 produces a high-level output signal in response to a sampling pulse from the VCO 12. As a result, the clock pulse from the clock pulse generator 54 is supplied to the AND gate 60 to control the counting operation of the counter 52. The output data of the counter 52 is supplied to the local D/A converter 56 which applies an analog signal corresponding to the output data of the counter 52 to the second input terminal of the comparator 50. When the counting operation of the counter 52 advances to cause a stepwise analog signal from the D/A converter 56 to be higher than the output signal from the sample and hold circuit 10, the comparator 50 produces a low-level signal. Consequently, the AND gate 60 is disabled, and interrupts the supply of the clock pulse from the clock pulse generator 54 to the counter 52. Thereafter, the register 62 receives the output data of the counter 52 in response to the trailing edge of the pulse from the pulse generator 58. In other words, the register 62 stores digital data corresponding to the analog input signal sampled and held by the sample and hold circuit 10. Thereafter, the counter 52 is cleared in response to the leading edge of the next pulse from the comparator 50.

Also, the stepwise analog output signal of the local D/A converter 56 is supplied to the control circuit 14, and the next sampling timing is determined by supplying the control voltage V_C to the VCO 12 in the same manner as described with reference to Fig. 4. Thus, the sample and hold circuit 10 samples and holds the analog input signal in response to the sampling pulses generated from the VCO 12 at a frequency controlled by the control voltage from the control circuit 14. Then, the register 62 stores digital data corresponding to the analog signal sampled by the sample and hold circuit 10.

Fig. 8 shows an analog signal storing circuit utilizing the sampled signal generation circuit shown in Fig. 3. This analog signal storing circuit basically has the same construction as that of the circuit shown in Fig. 7, except that it includes a memory circuit 64 for storing the count data from the counter 52 in response to the output pulses from the VCO 12, and a D/A converter 66 for converting a digital signal read out from the memory circuit 64 into a stepwise analog signal to supply an output signal to the control circuit 14.

Switches SW1 and SW2 are set in their respective first positions as shown in Fig. 8 when the storing circuit is in write-in mode. In this case, the storing circuit of Fig. 8 operates substantially in the same manner as the circuit of Fig. 7, except that the memory circuit 64 is substituted for the register 62. Namely, the VCO 12 produces sampling pulses at a frequency controlled by the control voltage V_C from the control circuit 14 and the sample and hold circuit 10 samples and holds the analog input signal in response to the sampling pulses from the VCO 12. The counter 52 produces count data corresponding to the

sampled signal from the sample and hold circuit 10, and the count data is written into the memory circuit 64 every time the trailing edge of the pulse from the pulse generator 58 is produced.

When the analog signal storing circuit is in readout mode, on the other hand, the switches SW1 and SW2 are set in their respective second positions. Namely, the output terminal of the VCO 12 is coupled to the read terminal of the memory circuit 64 through the switch SW1, and the output terminal of the D/A converter 66 is coupled to the input terminal of the control circuit 14 through the switch SW2.

In the readout mode, data stored in the memory circuit 64 are successively read out in response to the output pulses from the VCO 12. Each data read out from the memory circuit 64 is converted into a stepwise analog signal by the D/A converter 66, and then supplied to the control circuit 14. The control circuit 14 supplies to the VCO 12 a control signal corresponding to the difference between two stepwise signal components received successively, thereby causing the VCO 12 to produce sampling pulses at a frequency controlled in accordance with the difference between these two successive stepwise signal components. Thus, readout pulses are supplied from the VCO 12 to the read terminal of the memory circuit 64 in the same timing relationships as those of the sampling pulses supplied from the VCO 12 to the sample and hold circuit 10 in the write-in mode. As a result, a stepwise analog signal corresponding to the analog input signal supplied to the sample and hold circuit 10 is generated from the D/A converter 66 which converts the digital data read out from the memory circuit 64 into an analog signal. The input analog signal is restored by filtering the stepwise analog signal of the D/A converter 66.

Fig. 9 shows a sampled signal generation circuit according to a further embodiment of this invention.

This sampled signal generation circuit includes a sample and hold circuit 10 for sampling and holding an analog input signal in response to sampling pulses from a VCO 12, and control circuit 110 for detecting the gradient of the analog input signal and supplying to the VCO 12 an output voltage of a level corresponding to the absolute value of the gradient as a control voltage. The control circuit 110 controls the VCO 12 so that the sampling pulses may be generated therefrom at a high pulse rate when the gradient of the analog input signal is sharp. Accordingly, the greater the rate of change of the analog input signal, the higher the speed at which the sample and hold circuit 10 samples the analog input signal will be.

As shown in Fig. 10, for example, the control circuit 110 includes a differentiation circuit 112 for differentiating the analog input signal, and a nonlinear circuit 114 receiving an output signal from the differentiation circuit 112 through an absolute value circuit 116 and nonlinearly amplifying the input signal. The existence of the

nonlinear circuit 114 causes the VCO 12 to produce the sampling pulses at a sampling rate which monotonously increases with the increase of the gradient of the analog input signal and increases with a sharper gradient in a region where the gradient of the analog input signal is sharp than in a region where such gradient is gentle. This is done because, where the gradient of the analog input signal is sharp, sufficient number of sampled data to represent with high fidelity the analog input signal changing at a high changing rate are obtained by increasing the sampling frequency at a higher rate.

In an analog signal with limited frequency band, there is a correlation between the amplitude and the average of the absolute values of gradient. To sample such an analog signal, the control circuit 110 can be composed of a weighting circuit 118 for emphasizing the high frequency component of an input signal, a level detector 120 for detecting the level of the output signal of the weighting circuit 118, and a nonlinear circuit 122 for nonlinearly amplifying the output signal of the level detector 120 as shown in Fig. 12.

Fig. 13 shows an A/D converting circuit according to a further embodiment of this invention. This A/D converting circuit is constructed and operates in the same manner as the one shown in Fig. 7, except that a D/A converter 57 converts output data from the counter 52 into a filtered analog signal, and that a control circuit 110 supplies to the VCO 12 an output voltage corresponding to the gradient of the analog output signal from the D/A converter 57. This embodiment provides the same effect as obtained in the embodiment of Fig. 7.

Fig. 14 shows an analog signal storing circuit according to another embodiment of this invention. This analog signal storing circuit is constructed and operates in the same manner as the one shown in Fig. 8, except that the D/A converter 57 converts output data from the counter 52 into a filtered analog signal, and that the control circuit 110 supplies to the VCO 12 an output voltage corresponding to the gradient of the analog output signal from the D/A converter 57. This embodiment attains the same effect as obtained in the embodiment of Fig. 8.

Fig. 15 shows a sampled data generation circuit according to a further embodiment of this invention. In this generation circuit, a memory circuit 64 stores sampled data corresponding to the analog input signal in the write-in mode of the storing circuit shown in Fig. 14, for example. The memory circuit 64 is supplied with pulses generated from the VCO 12. The data successively read out from the memory circuit 64 are supplied to a D/A converter 130, and also to a D/A converter 132 through a delay circuit 134 which delays the input signal by one readout period in response to output pulses from the VCO 12. Output data $SD_{(n+1)}$ and SD_n from these D/A converters 130 and 132 are supplied to a difference detector 136, which produces an output data

$$\Delta SD_n (= |SD_{(n+1)} - SD_n|).$$

The output data ΔSD_n from the difference detector 136 is multiplied by a in a coefficient circuit 138, and the product is subtracted from "1" in an adder 140. Output data $(1 - a\Delta SD_n)$ from the adder 140 is multiplied by $1/b$ in a coefficient circuit 142, and the product is caused to reciprocate in a reciprocal circuit 144. Output data $(b/1 - a\Delta SD_n)$ generated from the reciprocal circuit 144 and corresponding to equation (5) is supplied as a control voltage V_c to the VCO 12. Thus, sampled data accompanied with time information are read out from the memory circuit 64, and an analog signal corresponding to the analog input signal is generated from the D/A converter 130 or 132.

Although illustrative embodiments of this invention have been described in detail herein, it is to be understood that the invention is not limited to those precise embodiments.

For example, it is possible to use a suitable VCO, such as one shown in Fig. 16 for the VCO 12, instead of the VCO shown in Fig. 5 which is used in the above embodiments to obtain the sampling timing given by eq. (1). In the VCO shown in Fig. 16, the output terminal of a polarity switching circuit 150 is coupled to the inverted input terminal of the integration circuit 42, and the output terminal of the voltage divider 40 is coupled to the positive input terminal of the comparator 44 whose negative input terminal is connected with the output terminal of the integration circuit 42. The output terminal of the comparator 44 is coupled to the pulse generator 48, and also to a monostable multivibrator 152 which produces a pulse with a predetermined pulse width every time the level of the output signal from the comparator 44 changes. A switch 154 is closed in response to the output pulse from the monostable multivibrator 152.

In the VCO shown in Fig. 16, when the output voltage of the comparator 44 is $+V_D$, the polarity switching circuit 150 inverts the control voltage V_c from the control circuit 14, and supplies the integration circuit 42 with an output voltage $-V_c$, thereby gradually increasing the output voltage of the integration circuit 42. When the output voltage of the integration circuit 42 becomes higher than that of the voltage divider 40, the output voltage of the comparator 44 becomes $-V_D$. As a result, the pulse generator 48 supplies an output pulse to the sample and hold circuit 10, and an output pulse with the predetermined pulse width is generated from the monostable multivibrator 152 to close the switch 154. Thus, the integration circuit 42 may hold the current output voltage for a predetermined period of time. Namely, the interval of the sampling pulses from the VCO of Fig. 16 depends on the sum of a predetermined constant time component and a time component in inverse proportion to the absolute value of the control voltage V_c from the control circuit 14, satisfying eq. (2).

Further, the control circuit 14 is connected so as

to receive the output data from the D/A converter 56 in the embodiment shown in Fig. 7, for example. Instead of doing this, however, the control circuit 14 may be connected so as to receive the output data from the sample and hold circuit 10.

In the storing circuit shown in Figs. 8 to 14, for example, the digital memory circuit 64 may be replaced with an analog memory, such as CCD memory or BBD memory, so that the output data from the sample and hold circuit 10 may be stored directly in the analog memory.

In the embodiment shown in Fig. 13, moreover, the control circuit 110 is connected so as to receive the output data from the D/A converter 57. Alternatively, however, the control circuit 110 may be connected so as to receive the output data from the sample and hold circuit 10.

Furthermore, sampled data can be transmitted without losing the time information therefor by supplying the digital data from the register 62 in Fig. 7 or 13 to a D/A converter 160 by means of a transmission line 162 so that the D/A converter 160 may be driven in accordance with sampling pulses transmitted from the VCO 12 by means of another transmission line 164 as shown in Fig. 17.

The VCO 12 and the control circuit 14 or 110 are used in the write-in and readout modes in the embodiments shown in Figs. 8 and 14. Alternatively, the circuit may be so arranged that the VCO 12 and the control circuit 14 or 110 are used only in the write-in mode, and the data may be read out from the memory circuit 64 by the use of a VCO 166 and a control circuit 168 separately provided as shown in Fig. 18.

Further, the differentiation circuit 112 shown in Fig. 10, which is to differentiate the analog signal, may be replaced with a gradient detecting circuit which samples the input analog signal and detects the gradient of the input analog signal from the difference between two successive sampled data and the sampling interval. In this case, the control circuit 110 can be replaced by a control circuit which detects the gradient of the input analog signal on the basis of two successive sampled data from the sample and hold circuit 10 and the sampling interval, and supplies the VCO 12 with an output signal corresponding to the detected gradient, thereby controlling the oscillation frequency of the VCO 12.

Claims

1. A sampled signal generation circuit comprising signal generating means (12), data generating means (10, 64) for successively sampling data in response to an output signal from said signal generating means (12), said signal generating means (12) producing an output signal at a frequency variable according to a control signal, and control means (14) for detecting the difference between two data sampled by said data generating means (10, 64) and supplying to said signal generating means (12) an output signal corresponding to said difference as said

control signal, thereby controlling said signal generating means (12) to increase or decrease the frequency of the output signal from said signal generating means (12) according as said difference becomes larger or smaller, the frequency of said output signal from said signal generating means (12) having a minimum positive value.

2. A sampled signal generation circuit according to claim 1, characterized in that said data generating means is formed of a sampling circuit (10) for sampling an analog input signal in response to the output signal from said signal generating means (12).

3. A sampled signal generation circuit according to claim 1 or 2, characterized in that said control means (14) includes a difference detecting circuit (16, 20) for detecting the difference between two data successively sampled by said data generating means (10) to produce an output signal corresponding to said difference, and an absolute value circuit (24) producing an output signal corresponding to the absolute value of the output signal from said difference detecting circuit (16, 20).

4. A sampled signal generation circuit according to claim 3, characterized in that said signal generating means (12) is formed of a voltage controlled oscillator with a frequency controlled in accordance with the control signal generated from said control means (14).

5. A sampled signal generation circuit according to claim 1 or 2, characterized in that said signal generating means (12) is formed of a voltage controlled oscillator with a frequency controlled in accordance with the control signal generated from said control means (14).

6. A sampled signal generation circuit according to claim 1, characterized in that said data generating means is formed of a memory circuit (64) from which stored sampled data are read out in response to the output signal from said signal generating means (12).

7. A sampled signal generation circuit according to claim 6, characterized in that said control means (14) includes a difference detecting circuit (16, 20) for detecting the difference between two data successively generated from said data generating means (10) to produce an output signal corresponding to said difference, and an absolute value circuit (24) producing an output signal corresponding to the absolute value of the output signal from said difference detecting circuit (16, 20).

8. A sampled signal generation circuit according to claim 7, characterized in that said signal generating means (12) is formed of a voltage controlled oscillator with a frequency controlled in accordance with the control signal generated from said control means (14).

9. A sampled signal generation circuit comprising signal generating means (12), data generating means (10, 64) for successively sampling data corresponding to an analog input signal in response to an output signal from said

signal generating means (12), said signal generating means (12) producing an output signal at a frequency variable according to a control signal, and control means (110) for supplying to said signal generating means (12) an output signal as said control signal corresponding to the gradient of the analog input signal, thereby controlling said signal generating means (12) to increase or decrease the frequency of the output signal from said signal generating means (12) according as said gradient becomes larger or smaller, the frequency of said output signal from said signal generating means having a minimum positive value.

10. A sampled signal generation circuit according to claim 9, characterized in that said data generating means is formed of a sampling circuit (10) for sampling an analog input signal in response to an output signal from said signal generating means (12).

11. A sampled signal generation circuit according to claim 9 or 10, characterized in that said control means (110) includes a differentiation circuit (112) for differentiating the analog input signal, and an absolute value circuit (116) producing an output signal corresponding to the absolute value of an output signal from said differentiation circuit (112).

12. A sampled signal generation circuit according to claim 11, characterized in that said control means (110) further includes a nonlinear circuit (114) for nonlinearly amplifying the output signal from said absolute value circuit (116).

13. A sampled signal generation circuit according to claim 11, characterized in that said signal generating means (12) is formed of a voltage controlled oscillator with a frequency controlled in accordance with the control signal generated by said control means (14).

14. A sampled signal generation circuit according to claim 9 or 10, characterized in that said control means (110) includes a gradient detecting circuit for detecting the gradient of the analog input signal on the basis of two data successively generated from said data generating means (10), and an absolute value circuit (116) producing an output signal corresponding to the absolute value of an output signal from said gradient detecting circuit.

15. A sampled signal generation circuit according to claim 14, characterized in that said control means (110) further includes a nonlinear circuit (114) for nonlinearly amplifying the output signal from said absolute value circuit (116).

16. A sampled signal generation circuit according to claim 14, characterized in that said signal generating means (12) is formed of a voltage controlled oscillator with a frequency controlled in accordance with the control signal generated from said control means (14).

17. A sampled signal generation circuit according to claim 9, characterized in that said data generating means is formed of a memory circuit (64) successively producing stored data in

response to the output signal from said signal generating means (12).

18. A sampled signal generation circuit according to claim 17, characterised in that said control means (110) includes a differentiation circuit (112) for differentiating the analog input signal, and an absolute value circuit (116) producing an output signal corresponding to the absolute value of an output signal from said differentiation circuit (112).

19. A sampled signal generation circuit according to claim 18, characterized in that said control means (110) further includes a nonlinear circuit (114) for non-linearly amplifying the output signal from said absolute value circuit (116).

20. A sampled signal generation circuit according to claim 18, characterized in that said signal generating means (12) is formed of a voltage controlled oscillator with a frequency controlled in accordance with the control signal generated from said control means (14).

21. A sampled signal generation circuit according to claim 17, characterized in that said control means (110) includes a gradient detecting circuit for detecting the gradient of the analog input signal on the basis of two data successively generated from said data generating means (10), and an absolute value circuit (116) producing an output signal corresponding to the absolute value of an output signal from said gradient detecting circuit.

22. A sampled signal generation circuit according to claim 21, characterized in that said control means (110) further includes a nonlinear circuit (114) for nonlinearly amplifying the output signal from said absolute value circuit (116).

23. A sampled signal generation circuit according to claim 21, characterized in that said signal generating means (12) is formed of a voltage controlled oscillator with a frequency controlled in accordance with the control signal generated from said control means (14).

24. An analog-digital converting circuit including a sampled signal generation circuit according to claim 1 and analog-digital converting means (50, 52, 54, 60) for converting analog data sampled by said sampling means (10) into digital data, characterized in that said analog-digital converting means comprises local digital-analog converting means (56) for converting an output signal from said analog-digital converting means (50, 52, 54, 60) into an analog signal.

25. An analog-digital converting circuit according to claim 24, characterized in that said signal generating means (12) is formed of a voltage controlled oscillator with a frequency controlled in accordance with the control signal generated from said control means (14).

26. An analog-digital converting circuit according to claim 24 or 25, further comprising a memory circuit (64) for successively storing digital signals from said analog-digital converting means (50, 52, 54, 60) in response to the output signal from said signal generating means (12).

27. An analog-digital converting circuit

including a sampled signal generation circuit according to claim 9 and analog-digital converting means (50, 52, 54, 60) for converting analog data sampled by said sampling means (10) into a digital data, characterized in that said analog-digital converting means further comprises local digital analog converting means (57) for converting an output signal from said analog-digital converting means (50, 52, 54, 60) into an analog signal, and control means (110) for detecting the differentiation value of an output signal from said digital-analog converting means (57) and supplying to said signal generating means (12) an output signal corresponding to said differentiation value as said control signal.

28. An analog-digital converting circuit according to claim 27, characterized in that said signal generating means (12) is formed of a voltage controlled oscillator with a frequency controlled in accordance with the control signal generated from said control means (14).

29. An analog-digital converting circuit according to claim 27 or 28, further comprising a memory circuit (64) for successively storing digital signals from said analog-digital converting means (50, 52, 54, 60) in response to the output signal from said signal generating means (12).

Patentansprüche

1. Abtastsignal-Generatorschaltung mit einer Signalgeneratoreinrichtung (12), einer Datengeneratoreinrichtung (10, 64) zum aufeinanderfolgenden Abtasten von Daten abhängig von einem Ausgangssignal von der Signalgeneratoreinrichtung (12), die ein Ausgangssignal mit einer entsprechend einem Steuersignal veränderlichen Frequenz erzeugt, und einer Steuereinrichtung (14) zum Erfassen der Differenz zwischen zwei durch die Datengeneratoreinrichtung (10, 64) abgetasteten Daten und zum Einspeisen eines dieser Differenz entsprechenden Ausgangssignals als Steuersignal in die Signalgeneratoreinrichtung (12), um die Signalgeneratoreinrichtung (12) so zu steuern, daß die Frequenz des Ausgangssignales von der Signalgeneratoreinrichtung (12) mit größer oder kleiner werdender Differenz zunimmt oder abnimmt, wobei die Frequenz des Ausgangssignales von der Signalgeneratoreinrichtung (12) einen kleinsten positiven Wert hat.

2. Abtastsignal-Generatorschaltung nach Anspruch 1, dadurch gekennzeichnet, daß die Datengeneratoreinrichtung aus einer Abtastschaltung (10) zum Abtasten eines analogen Eingangssignales abhängig vom Ausgangssignal von der Signalgeneratoreinrichtung (12) besteht.

3. Abtastsignal-Generatorschaltung nach Anspruch 1 oder 2, dadurch gekennzeichnet, daß die Steuereinrichtung (14) eine Differenzdetektorschaltung (16, 20) zum Erfassen der Differenz zwischen zwei nacheinander durch die Datengeneratoreinrichtung (10) abgetasteten Daten, um ein Ausgangssignal entsprechend dieser Differenz zu erzeugen, und eine

Absolutwertschaltung (24), die ein Ausgangssignal entsprechend dem Absolutwert des Ausgangssignales von der Differenzdetektorschaltung (16, 20) erzeugt, erfaßt.

4. Abtastsignal-Generatorschaltung nach Anspruch 3, dadurch gekennzeichnet, daß die Signalgeneratoreinrichtung (12) aus einem spannungsgesteuerten Oszillator mit einer Frequenz besteht, die entsprechend dem von der Steuereinrichtung (14) erzeugten Steuersignal gesteuert ist.

5. Abtastsignal-Generatorschaltung nach Anspruch 1 oder 2, dadurch gekennzeichnet, daß die Signalgeneratoreinrichtung (12) aus einem spannungsgesteuerten Oszillator mit einer Frequenz besteht, die entsprechend dem von der Steuereinrichtung (14) erzeugten Steuersignal gesteuert ist.

6. Abtastsignal-Generatorschaltung nach Anspruch 1, dadurch gekennzeichnet, daß die Datengeneratoreinrichtung aus einer Speicherschaltung (64) besteht, aus der gespeicherte abgetastete Daten abhängig von dem Ausgangssignal von der Signalgeneratoreinrichtung (12) ausgelesen werden.

7. Abtastsignal-Generatorschaltung nach Anspruch 6, dadurch gekennzeichnet, daß die Steuereinrichtung (14) eine Differenzdetektorschaltung (16, 20) zum Erfassen der Differenz zwischen zwei nacheinander von der Datengeneratoreinrichtung (10) erzeugten Daten, um ein Ausgangssignal entsprechend dieser Differenz zu erzeugen, und eine Absolutwertschaltung (24), die ein Ausgangssignal entsprechend dem Absolutwert des Ausgangssignales von der Differenzdetektorschaltung (16, 20) erzeugt, aufweist.

8. Abtastsignal-Generatorschaltung nach Anspruch 7, dadurch gekennzeichnet, daß die Signalgeneratoreinrichtung (12) aus einem spannungsgesteuerten Oszillator mit einer Frequenz besteht, die entsprechend dem von der Steuereinrichtung (14) erzeugten Steuersignal gesteuert ist.

9. Abtastsignal-Generatorschaltung mit einer Signalgeneratoreinrichtung (12), einer Datengeneratoreinrichtung (10, 64) zum aufeinanderfolgenden Abtasten von Daten entsprechend einem analogen Eingangssignale abhängig von einem Ausgangssignal von der Signalgeneratoreinrichtung (12) die ein Ausgangssignal mit einer entsprechend einem Steuersignal veränderlichen Frequenz erzeugt, und einer Steuereinrichtung (110), um in die Signalgeneratoreinrichtung (12) ein Ausgangssignal als das Steuersignal entsprechend dem Gradienten des analogen Eingangssignales einzuspeisen, wodurch die Signalgeneratoreinrichtung (12) derart gesteuert ist, daß die Frequenz des Ausgangssignales von der Signalgeneratoreinrichtung (12) mit größer oder kleiner werdendem Gradienten zunimmt bzw. abnimmt, wobei die Frequenz des Ausgangssignales von der Signalgeneratoreinrichtung einen kleinsten positiven Wert hat.

10. Abtastsignal-Generatorschaltung nach Anspruch 9, dadurch gekennzeichnet, daß die Datengeneratoreinrichtung aus einer Abtasterschaltung (10) besteht, um ein analoges Eingangssignal abhängig von einem Ausgangssignal von der Signalgeneratoreinrichtung (12) abzutasten.

11. Abtastsignal-Generatorschaltung nach Anspruch 9 oder 10, dadurch gekennzeichnet, daß die Steuereinrichtung (110) eine Differenzerschaltung (112) zum Differenzieren des analogen Eingangssignales und eine Absolutwertschaltung (116) zum Erzeugen eines Ausgangssignales entsprechend dem Absolutwert eines Ausgangssignales von der Differenzerschaltung (112) aufweist.

12. Abtastsignal-Generatoreinrichtung nach Anspruch 11, dadurch gekennzeichnet, daß die Steuereinrichtung (110) weiterhin eine nicht-lineare Schaltung (114) zum nicht-linearen Verstärken des Ausgangssignales von der Absolutwertschaltung (116) aufweist.

13. Abtastsignal-Generatorschaltung nach Anspruch 11, dadurch gekennzeichnet, daß die Signalgeneratoreinrichtung (12) aus einem spannungsgesteuerten Oszillator mit einer Frequenz besteht, die entsprechend dem von der Steuereinrichtung (14) erzeugten Steuersignal gesteuert ist.

14. Abtastsignal-Generatorschaltung nach Anspruch 9 oder 10, dadurch gekennzeichnet, daß die Steuereinrichtung (110) eine Gradientendetektorschaltung zum Erfassen des Gradienten des analogen Eingangssignales aufgrund von zwei nacheinander von der Datengeneratoreinrichtung (10) erzeugten Daten und eine Absolutwertschaltung (116) zum Erzeugen eines Ausgangssignales entsprechend dem Absolutwert eines Ausgangssignales von der Gradientendetektorschaltung aufweist.

15. Abtastsignal-Generatorschaltung nach Anspruch 14, dadurch gekennzeichnet, daß die Steuereinrichtung (110) weiterhin eine nicht-lineare Schaltung (114) zum nicht-linearen Verstärken des Ausgangssignales von der Absolutwertschaltung (116) aufweist.

16. Abtastsignal-Generatorschaltung nach Anspruch 14, dadurch gekennzeichnet, daß die Signalgeneratoreinrichtung (12) aus einem spannungsgesteuerten Oszillator mit einer Frequenz besteht, die entsprechend dem von der Steuereinrichtung (14) erzeugten Steuersignal gesteuert ist.

17. Abtastsignal-Generatorschaltung nach Anspruch 9, dadurch gekennzeichnet, daß die Datengeneratoreinrichtung aus einer Speicherschaltung (64) besteht, die nacheinander gespeicherte Daten abhängig von dem Ausgangssignal von der Signalgeneratoreinrichtung (12) erzeugt.

18. Abtastsignal-Generatorschaltung nach Anspruch 17, dadurch gekennzeichnet, daß die Steuereinrichtung (110) eine Differenzerschaltung (112) zum Differenzieren des analogen Eingangssignales und eine Absolutwertschaltung

(116), die ein Ausgangssignal entsprechend dem Absolutwert eines Ausgangssignales von der Differenzerschaltung (112) erzeugt, aufweist.

19. Abtastsignal-Generatorschaltung nach Anspruch 18, dadurch gekennzeichnet, daß die Steuereinrichtung (110) weiterhin eine nicht-lineare Schaltung (114) zum nicht-linearen Verstärken des Ausgangssignales von der Absolutwertschaltung (116) aufweist.

20. Abtastsignal-Generatorschaltung nach Anspruch 18, dadurch gekennzeichnet, daß die Signalgeneratoreinrichtung (12) aus einem spannungsgesteuerten Oszillator mit einer Frequenz besteht, die entsprechend dem von der Steuereinrichtung (14) erzeugten Steuersignal gesteuert ist.

21. Abtastsignal-Generatorschaltung nach Anspruch 17, dadurch gekennzeichnet, daß die Steuereinrichtung (110) eine Gradientendetektorschaltung zum Erfassen des Gradienten des analogen Eingangssignales aufgrund von zwei nacheinander von der Datengeneratoreinrichtung (10) erzeugten Daten und eine Absolutwertschaltung (116) zum Erzeugen eines Ausgangssignales entsprechend dem Absolutwert eines Ausgangssignales von der Gradientendetektorschaltung aufweist.

22. Abtastsignal-Generatorschaltung nach Anspruch 21, dadurch gekennzeichnet, daß die Steuereinrichtung (110) weiterhin eine nicht-lineare Schaltung (114) zum nicht-linearen Verstärken des Ausgangssignales von der Absolutwertschaltung (116) aufweist.

23. Abtastsignal-Generatorschaltung nach Anspruch 21, dadurch gekennzeichnet, daß die Signalgeneratoreinrichtung (12) aus einem spannungsgesteuerten Oszillator mit einer Frequenz besteht, die entsprechend dem von der Steuereinrichtung (14) erzeugten Steuersignal gesteuert ist.

24. Analog/Digital-Umsetzerschaltung mit einer Abtastsignal-Generatorschaltung nach Anspruch 1 und einer Analog/Digital-Umsetzereinrichtung (50, 52, 54, 60) zum Umsetzen analoger, von der Abtasteinrichtung (10) abgetasteter Daten in digitale Daten, dadurch gekennzeichnet, daß die Analog/Digital-Umsetzereinrichtung eine lokale Digital/Analog-Umsetzereinrichtung (56) zum Umsetzen eines Ausgangssignales von der Analog/Digital-Umsetzereinrichtung (50, 52, 54, 60) in ein analoges Signal aufweist.

25. Analog/Digital-Umsetzerschaltung nach Anspruch 24, dadurch gekennzeichnet, daß die Signalgeneratoreinrichtung (12) aus einem spannungsgesteuerten Oszillator mit einer Frequenz besteht, die entsprechend dem von der Steuereinrichtung (14) erzeugten Steuersignal gesteuert ist.

26. Analog/Digital-Umsetzerschaltung nach Anspruch 24 oder 25, mit weiterhin einer Speicherschaltung (64) zum aufeinanderfolgenden Speichern von digitalen Signalen von der Analog/Digital-Umsetzereinrichtung (50, 52, 54, 60) anhängig vom Ausgangssignal von der Signalgeneratoreinrichtung (12).

27. Analog Digital-Umsetzerschaltung mit einer Abtastsignal-Generatorschaltung nach Anspruch 9 und einer Analog/Digital-Umsetzereinrichtung (50, 52, 54, 60) zum Umsetzen analoger, durch die Abtasteinrichtung (10) abgetasteter Daten in digitale Daten, dadurch gekennzeichnet, daß die Analog/Digital-Umsetzereinrichtung weiterhin eine lokale Digital/Analog-Umsetzereinrichtung (57) zum Umsetzen eines Ausgangssignales von der Analog/Digital-Umsetzereinrichtung (50, 52, 54, 60) in ein analoges Signal und eine Steuereinrichtung (110) zum Erfassen des Differenzwertes eines Ausgangssignales von der Digital/Analog-Umsetzereinrichtung (57) und zum Einspeisen eines Ausgangssignales entsprechend dem Differenzwert als Steuersignal in die Signalgeneratoreinrichtung (12) aufweist.

28. Analog/Digital-Umsetzerschaltung nach Anspruch 27, dadurch gekennzeichnet, daß die Signalgeneratoreinrichtung (12) aus einem spannungsgesteuerten Oszillator mit einer Frequenz besteht, die entsprechend dem von der Steuereinrichtung (14) erzeugten Steuersignal gesteuert ist.

29. Analog/Digital-Umsetzerschaltung nach Anspruch 27 oder 28, mit weiterhin einer Speicherschaltung (64) zum aufeinanderfolgenden Speichern digitaler Signale von der Analog/Digital-Umsetzereinrichtung (50, 52, 54, 60) abhängig von dem Ausgangssignal von der Signalgeneratoreinrichtung (12).

Revendications

1. Circuit de génération de signal échantillonné comprenant un moyen de génération de signal (12), un moyen de génération de données (10, 64) pour échantillonner successivement des données en réponse à un signal de sortie en provenance du moyen de génération de signal (12), ce moyen de génération de signal (12) produisant un signal de sortie à une fréquence variable en fonction d'un signal de commande, et un moyen de commande (14) pour détecter la différence entre deux données échantillonnées par le moyen de génération de données (10, 64) et fournissant au moyen de génération de signal (12) un signal de sortie correspondant à cette différence en tant que signal de commande, commandant ainsi le moyen de génération de signal (12) pour augmenter ou diminuer la fréquence du signal de sortie en provenance du moyen de génération de signal (12) selon que ladite différence devient plus grande ou plus petite, la fréquence du signal de sortie en provenance du moyen de génération de signal (12) ayant une valeur positive minimale.

2. Circuit de génération de signal échantillonné selon la revendication 1, caractérisé en ce que le moyen de génération de données est constitué d'un circuit d'échantillonnage (10) pour échantillonner un signal d'entrée analogique en réponse au signal de sortie en provenance du moyen de génération de signal (12).

3. Circuit de génération de signal échantillonné selon l'une des revendications 1 ou 2, caractérisé

en ce que le moyen de commande (14) comprend un circuit de détection de différence (16, 20) pour détecter la différence entre deux données successivement échantillonnées par le moyen de génération de données (10) pour produire un signal de sortie qui correspond à ladite différence, et un circuit de valeur absolue (24) produisant un signal de sortie qui correspond à la valeur absolue du signal de sortie en provenance du circuit de détection de différence (16, 20).

4. Circuit de génération de signal échantillonné selon la revendication 3, caractérisé en ce que le moyen de génération de signal (12) est constitué d'un oscillateur commandé en tension dont la fréquence est commandée en relation avec le signal de commande produit par le moyen de commande (14).

5. Circuit de génération de signal échantillonné selon l'une des revendications 1 ou 2, caractérisé en ce que le moyen de génération de signal (12) est constitué d'un oscillateur commandé en tension dont la fréquence est commandée en relation avec le signal de commande produit par le moyen de commande (14).

6. Circuit de génération de signal échantillonné selon la revendication 1, caractérisé en ce que le moyen de génération de données est constitué d'un circuit de mémoire (64) à partir duquel des données échantillonnées sont lues en réponse au signal de sortie en provenance du moyen de génération de signal (12).

7. Circuit de génération de signal échantillonné selon la revendication 6, caractérisé en ce que le moyen de commande (14) comprend un circuit de détection de différence (16, 20) pour détecter la différence entre deux données successivement échantillonnées par le moyen de génération de données (10) pour produire un signal de sortie qui correspond à ladite différence, et un circuit de valeur absolue (24) produisant un signal de sortie qui correspond à la valeur absolue du signal de sortie en provenance du circuit de détection de différence (16, 20).

8. Circuit de génération de signal échantillonné selon la revendication 7, caractérisé en ce que le moyen de génération de signal (12) est constitué d'un oscillateur commandé en tension dont la fréquence est commandée en relation avec le signal de commande produit par le moyen de commande (14).

9. Circuit de génération de signal échantillonné comprenant un moyen de génération de signal (12), un moyen de génération de données (10, 64) pour échantillonner successivement des données en réponse à un signal de sortie en provenance du moyen de génération de signal (12), ce moyen de génération de données (10, 64) produisant un signal de sortie à une fréquence variable en fonction d'un signal de commande, et un moyen de commande (110) pour fournir au moyen de génération de signal (12) un signal de sortie en tant que signal de commande correspondant au gradient du signal d'entrée analogique, commandant ainsi le moyen de génération de signal (12) pour augmenter ou diminuer la

fréquence du signal de sortie en provenance du moyen de génération de signal (12) selon que ladite différence devient plus grande ou plus petite, la fréquence du signal de sortie en provenance du moyen de génération de signal ayant une valeur positive minimale.

10. Circuit de génération de signal échantillonné selon la revendication 9, caractérisé en ce que le moyen de génération de données est constitué d'un circuit d'échantillonnage (10) pour échantillonner un signal d'entrée analogique en réponse au signal de sortie en provenance du moyen de génération de signal (12).

11. Circuit de génération de signal échantillonné selon l'une des revendications 9 ou 10, caractérisé en ce que le moyen de commande (110) comprend un circuit de différentiation (112) pour différencier le signal d'entrée analogique et un circuit de valeur absolue (116) produisant un signal de sortie qui correspond à la valeur absolue du signal de sortie en provenance du circuit de différentiation (112).

12. Circuit de génération de signal échantillonné selon la revendication 11, caractérisé en ce que le moyen de commande (110) comprend en outre un circuit non linéaire (114) pour amplifier non linéairement le signal de sortie en provenance du circuit de valeur absolue (116).

13. Circuit de génération de signal échantillonné selon la revendication 11, caractérisé en ce que le moyen de génération de signal (12) est constitué d'un oscillateur commandé en tension dont la fréquence est commandée en relation avec le signal de commande produit par le moyen de commande (14).

14. Circuit de génération de signal échantillonné selon l'une des revendications 9 ou 10, caractérisé en ce que le moyen de commande (110) comprend un circuit de détection de gradient pour détecter le gradient du signal d'entrée analogique sur la base de deux données produites successivement par le moyen de génération de données (10), et un circuit de valeur absolue (116) produisant un signal de sortie qui correspond à la valeur absolue du signal de sortie en provenance du circuit de détection de gradient.

15. Circuit de génération de signal échantillonné selon la revendication 14, caractérisé en ce que le moyen de commande (110) comprend en outre un circuit non linéaire (114) pour amplifier non linéairement le signal de sortie en provenance du circuit de valeur absolue (116).

16. Circuit de génération de signal échantillonné selon la revendication 14, caractérisé en ce que le moyen de génération de signal (12) est constitué d'un oscillateur commandé en tension dont la fréquence est commandée en relation avec le signal de commande produit par le moyen de commande (14).

17. Circuit de génération de signal échantillonné selon la revendication 9, caractérisé en ce que le moyen de génération de données est constitué d'un circuit de mémoire (64) produisant successivement des données mémorisées en

réponse au signal de sortie en provenance du moyen de génération de signal (12).

18. Circuit de génération de signal échantillonné selon la revendication 17, caractérisé en ce que le moyen de commande (110) comprend un circuit de différentiation (112) pour différencier le signal d'entrée analogique et un circuit de valeur absolue (116) produisant un signal de sortie qui correspond à la valeur absolue du signal de sortie en provenance du circuit de différentiation (112).

19. Circuit de génération de signal échantillonné selon la revendication 18, caractérisé en ce que le moyen de commande (110) comprend en outre un circuit non linéaire (114) pour amplifier non linéairement le signal de sortie en provenance du circuit de valeur absolue (116).

20. Circuit de génération de signal échantillonné selon la revendication 18, caractérisé en ce que le moyen de génération de signal (12) est constitué d'un oscillateur commandé en tension dont la fréquence est commandée en relation avec le signal de commande produit par le moyen de commande (14).

21. Circuit de génération de signal échantillonné selon la revendication 17, caractérisé en ce que le moyen de commande (110) comprend un circuit de détection de gradient pour détecter le gradient du signal d'entrée analogique sur la base de deux données produites successivement par le moyen de génération de données (10), et un circuit de valeur absolue (116) produisant un signal de sortie qui correspond à la valeur absolue du signal de sortie en provenance du circuit de détection de gradient.

22. Circuit de génération de signal échantillonné selon la revendication 21, caractérisé en ce que le moyen de commande (110) comprend en outre un circuit non linéaire (114) pour amplifier non linéairement le signal de sortie en provenance du circuit de valeur absolue (116).

23. Circuit de génération de signal échantillonné selon la revendication 21, caractérisé en ce que le moyen de génération de signal (12) est constitué d'un oscillateur commandé en tension dont la fréquence est commandée en relation avec le signal de commande produit par le moyen de commande (14).

24. Circuit de conversion analogique/numérique comprenant un circuit de génération de signal échantillonné selon la revendication 1, et un moyen de conversion analogique/numérique (50, 52, 54, 60) pour convertir des données analogiques échantillonnées par le moyen d'échantillonnage (10) en données numériques, caractérisé en ce que le moyen de conversion analogique/numérique comprend un

moyen de conversion numérique/analogique local (56) pour convertir le signal de sortie en provenance du moyen de conversion analogique/numérique (50, 52, 54, 60) en un signal analogique.

25. Circuit de conversion analogique/numérique selon la revendication 24, caractérisé en ce que le moyen de génération de signal (12) est constitué d'un oscillateur commandé en tension dont la fréquence est commandée en relation avec le signal de commande produit par le moyen de conversion (14).

26. Circuit de conversion analogique/numérique selon l'une des revendications 24 ou 25, caractérisé en ce qu'il comprend en outre un circuit de mémoire (64) pour mémoriser successivement des signaux numériques en provenance du moyen de conversion analogique/numérique (50, 52, 54, 60) en réponse au signal de sortie en provenance du moyen de génération de signal (12).

27. Circuit de conversion analogique/numérique comprenant un circuit de génération de signal échantillonné selon la revendication 9, et un moyen de conversion analogique/numérique (50, 52, 54, 60) pour convertir des données analogiques échantillonnées par le moyen d'échantillonnage (10) en données numériques, caractérisé en ce que le moyen de conversion analogique/numérique comprend en outre un moyen de conversion numérique/analogique local (57) pour convertir le signal de sortie en provenance du moyen de conversion analogique/numérique (50, 52, 54, 60) en un signal analogique, et un moyen de commande (110) pour détecter la valeur de différentiation du signal de sortie en provenance du moyen de conversion numérique/analogique (57) et fournir à ce moyen de génération de signal (12) un signal de sortie correspondant à la valeur de différentiation en tant que signal de commande.

28. Circuit de conversion analogique/numérique selon la revendication 27, caractérisé en ce que le moyen de génération de signal (12) est constitué d'un oscillateur commandé en tension dont la fréquence est commandée en relation avec le signal de commande produit par le moyen de commande (14).

29. Circuit de conversion analogique/numérique selon l'une des revendications 27 ou 28, caractérisé en ce qu'il comprend en outre un circuit de mémoire (64) pour mémoriser successivement des signaux numériques en provenance du moyen de conversion analogique/numérique (50, 52, 54, 60) en réponse au signal de sortie en provenance du moyen de génération de signal (12).

5

10

15

20

25

30

35

40

45

50

55

60

65

13

FIG. 1A

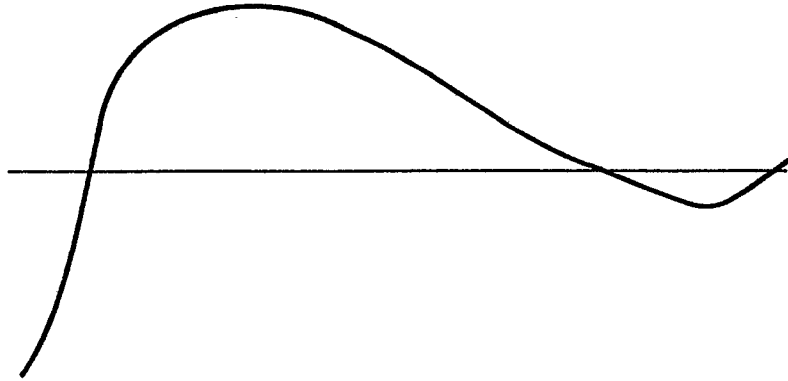

FIG. 1B



FIG. 1C

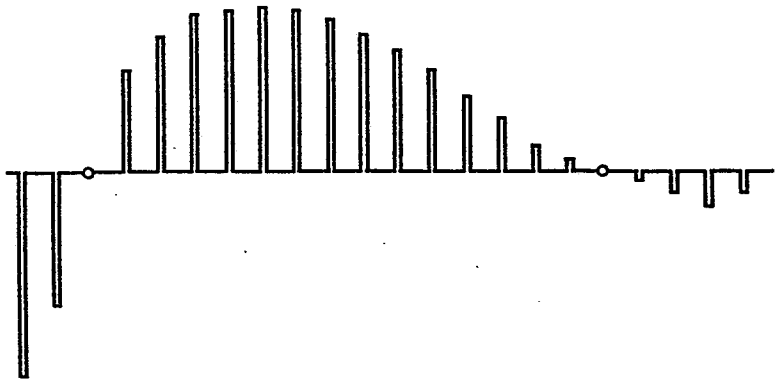

FIG. 1D

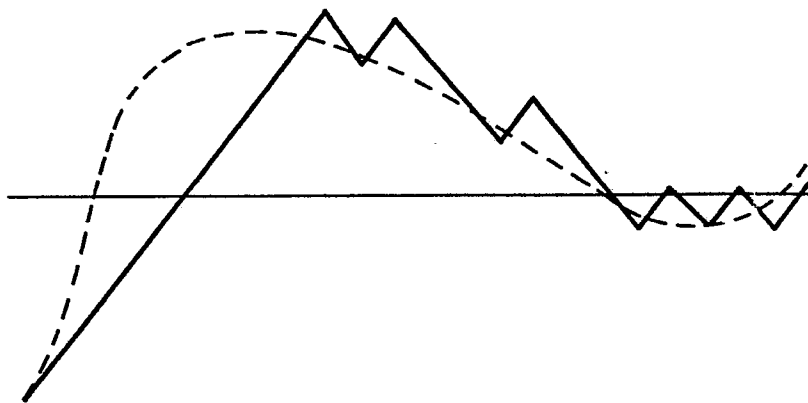

FIG. 2A

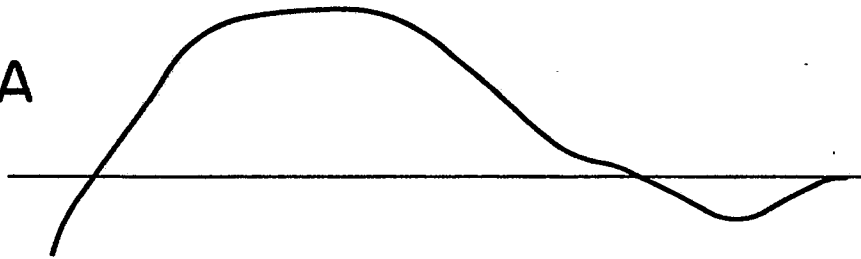

FIG. 2B

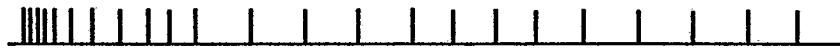

FIG. 2C

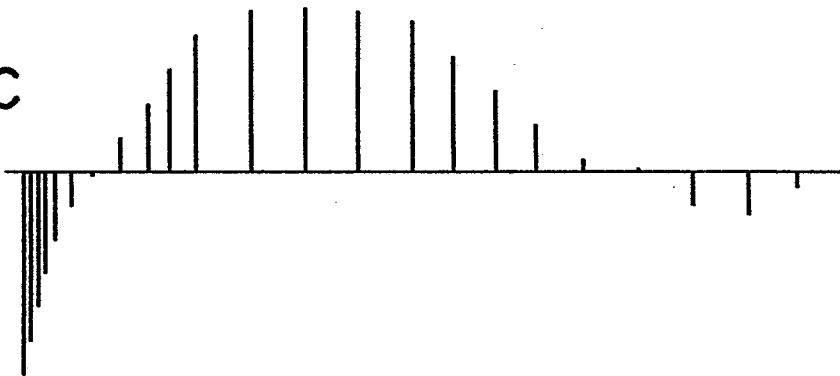

FIG. 2D

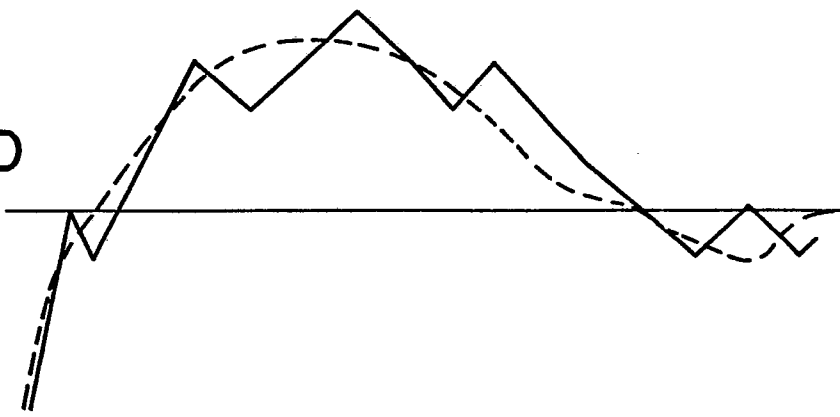

FIG. 3

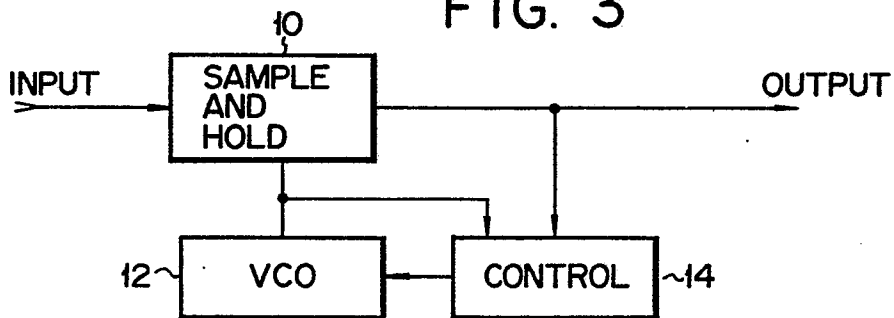

FIG. 4

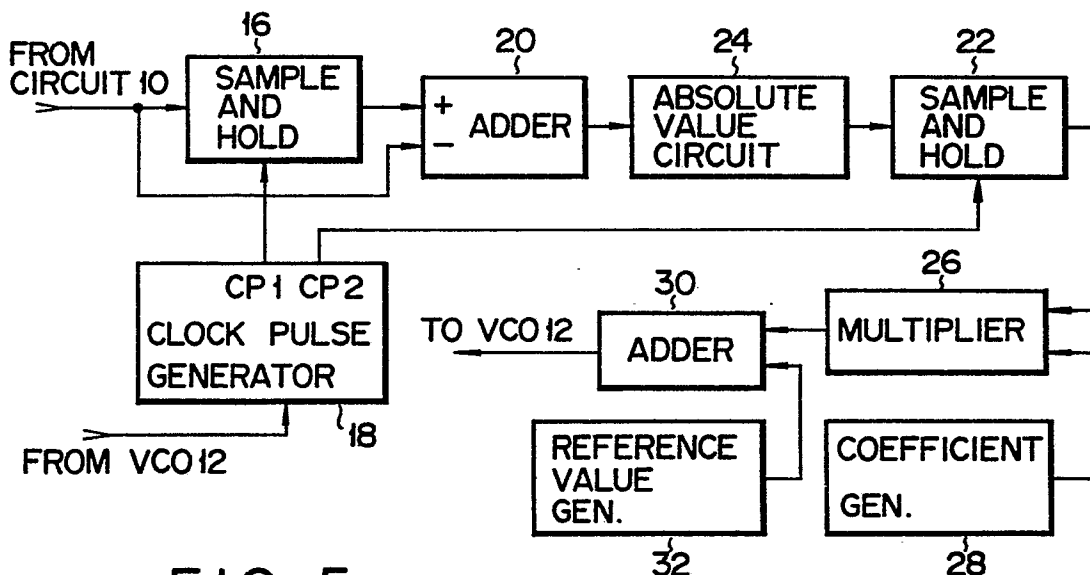
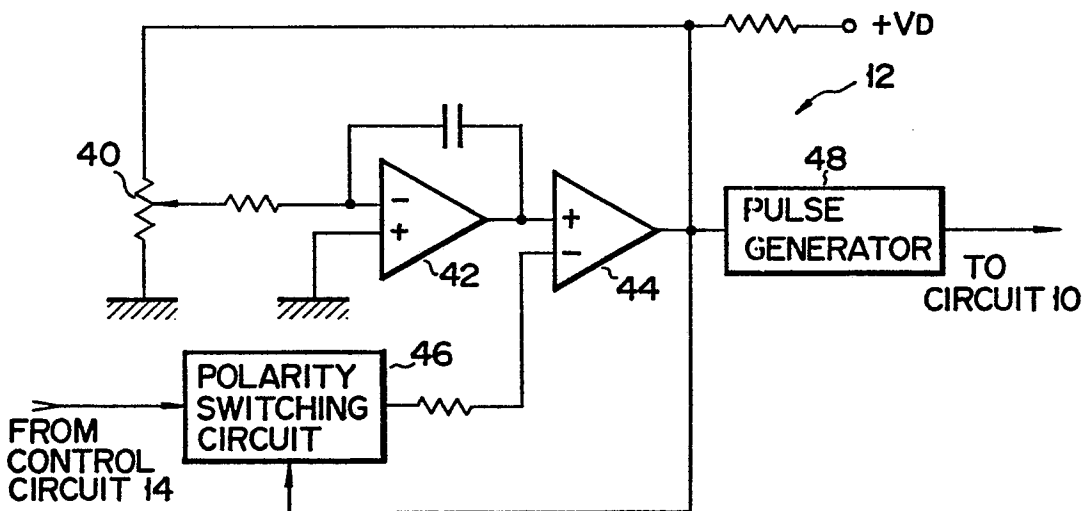
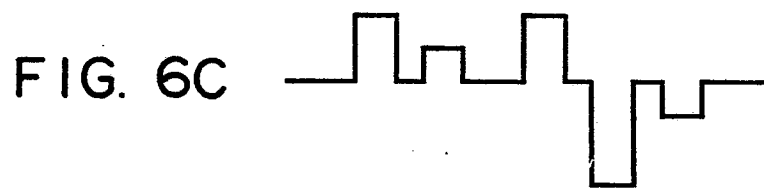
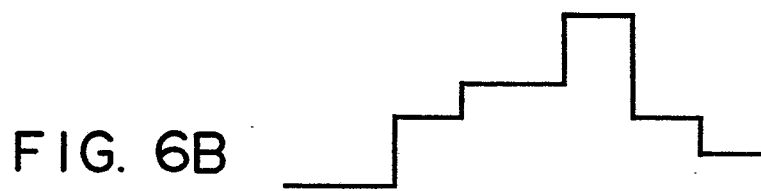
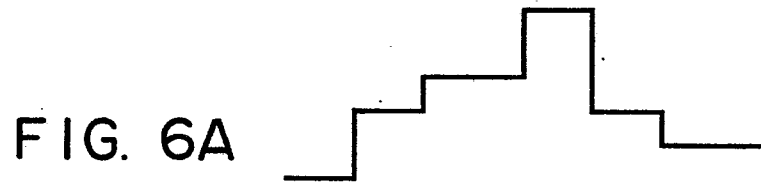

FIG. 5





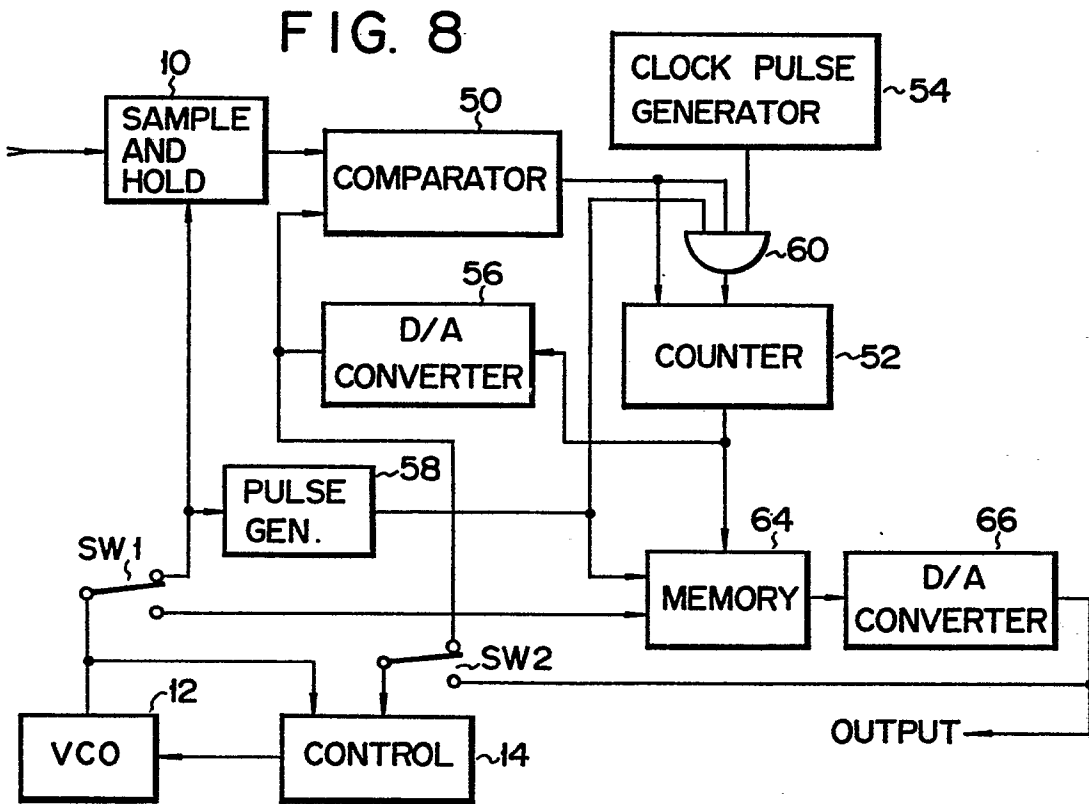
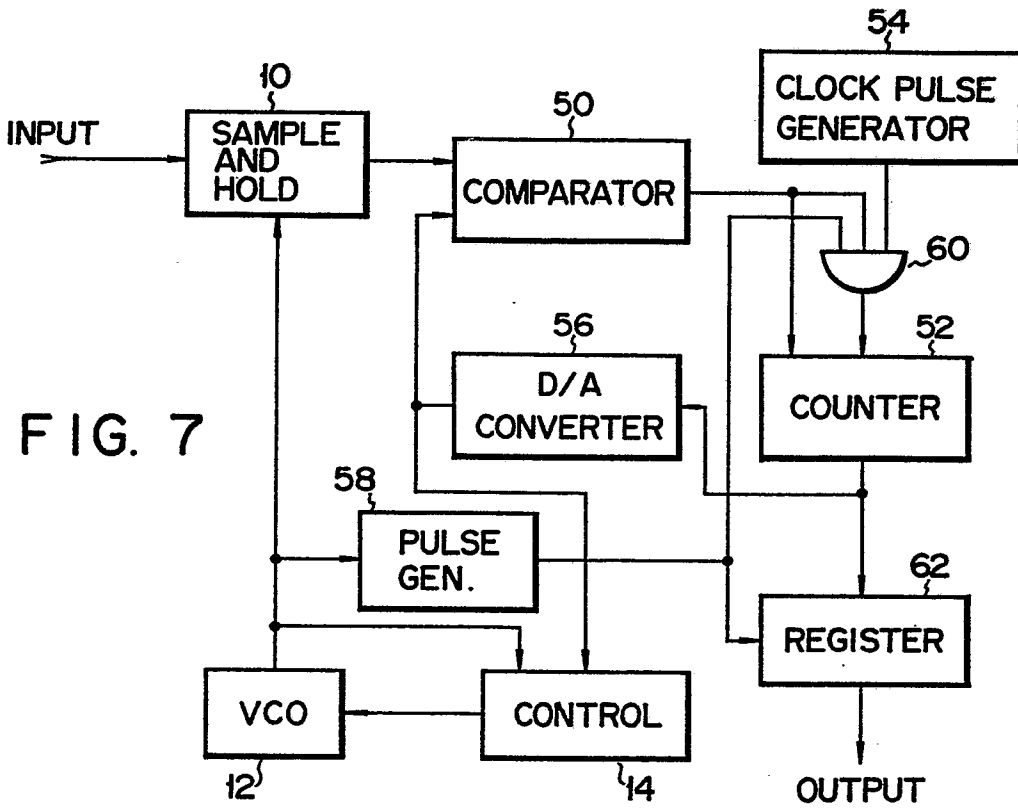

FIG. 9

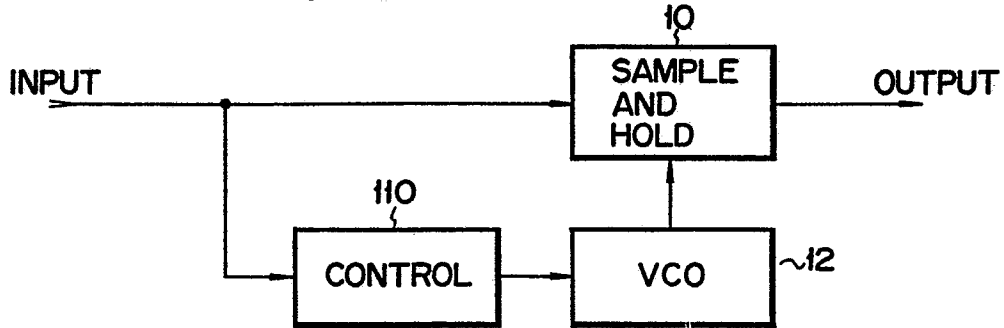

FIG. 10

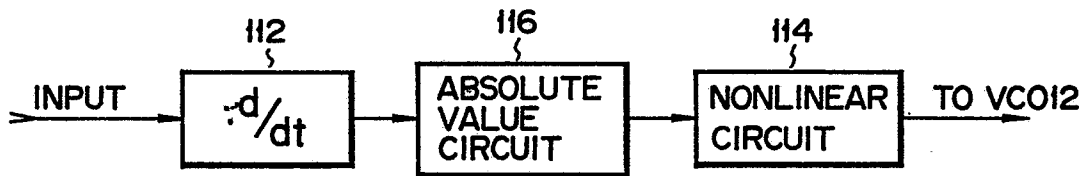

FIG. 11

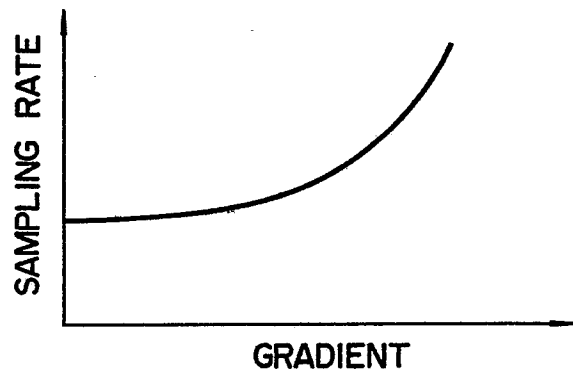
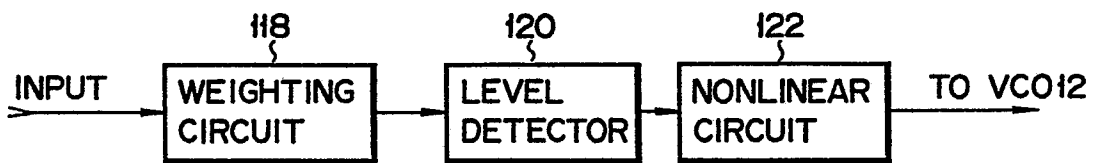

FIG. 12



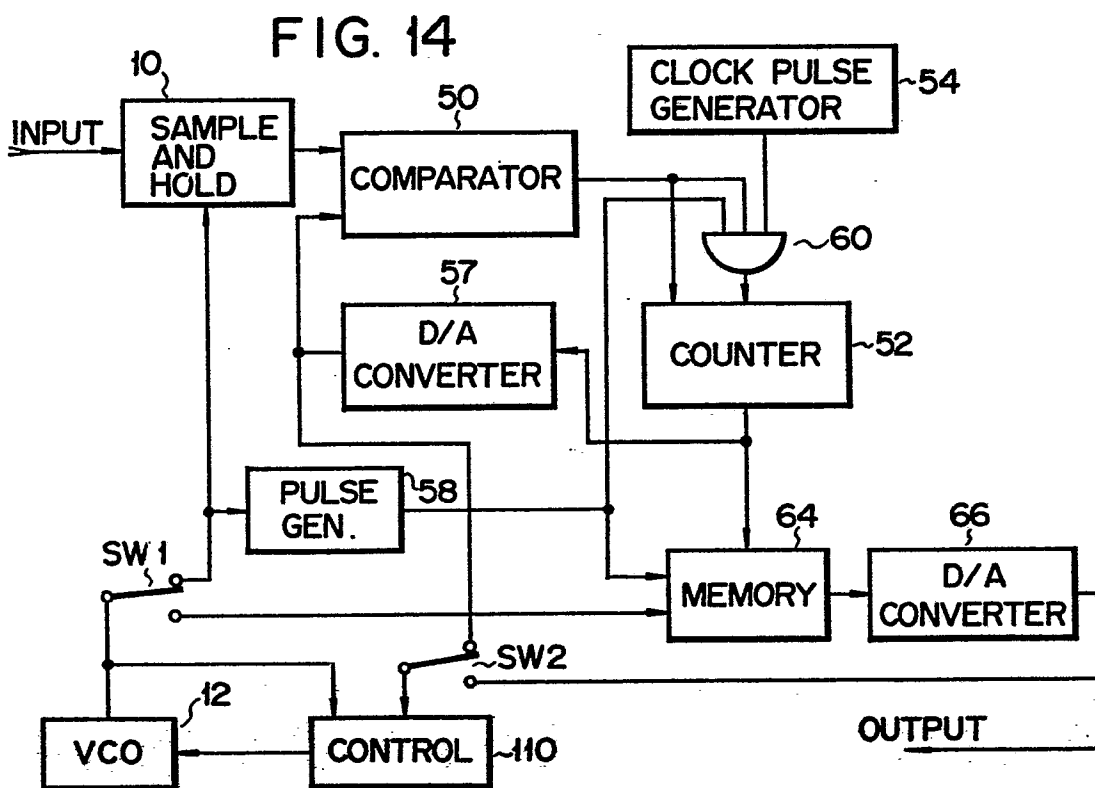
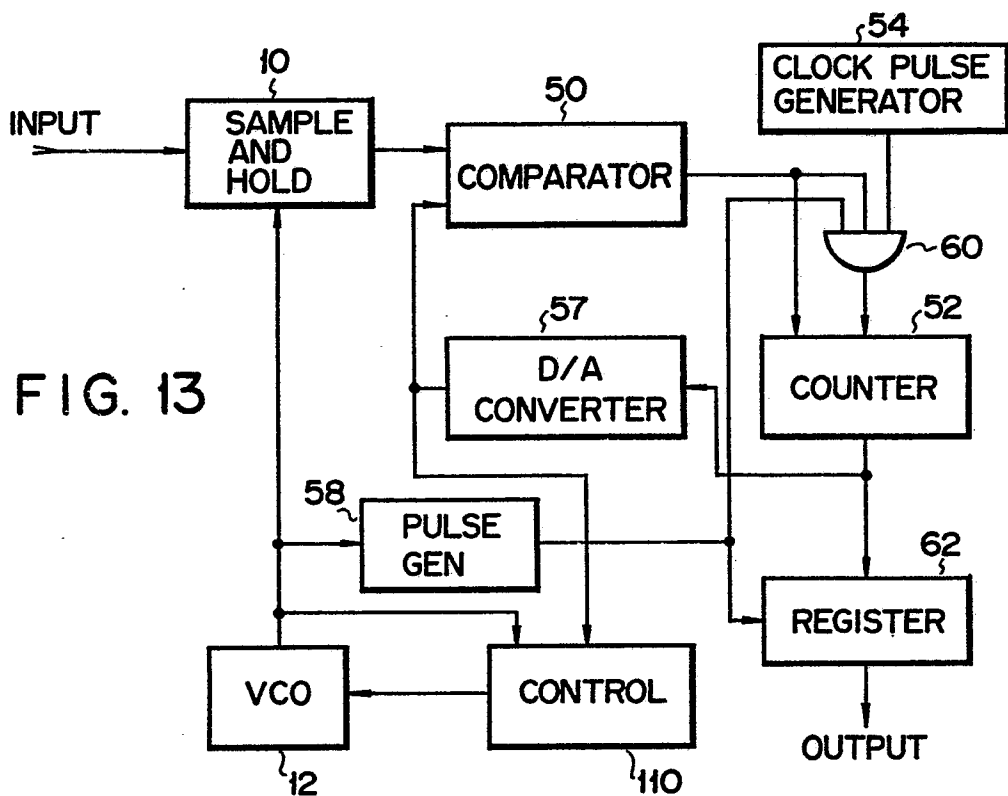

FIG. 15

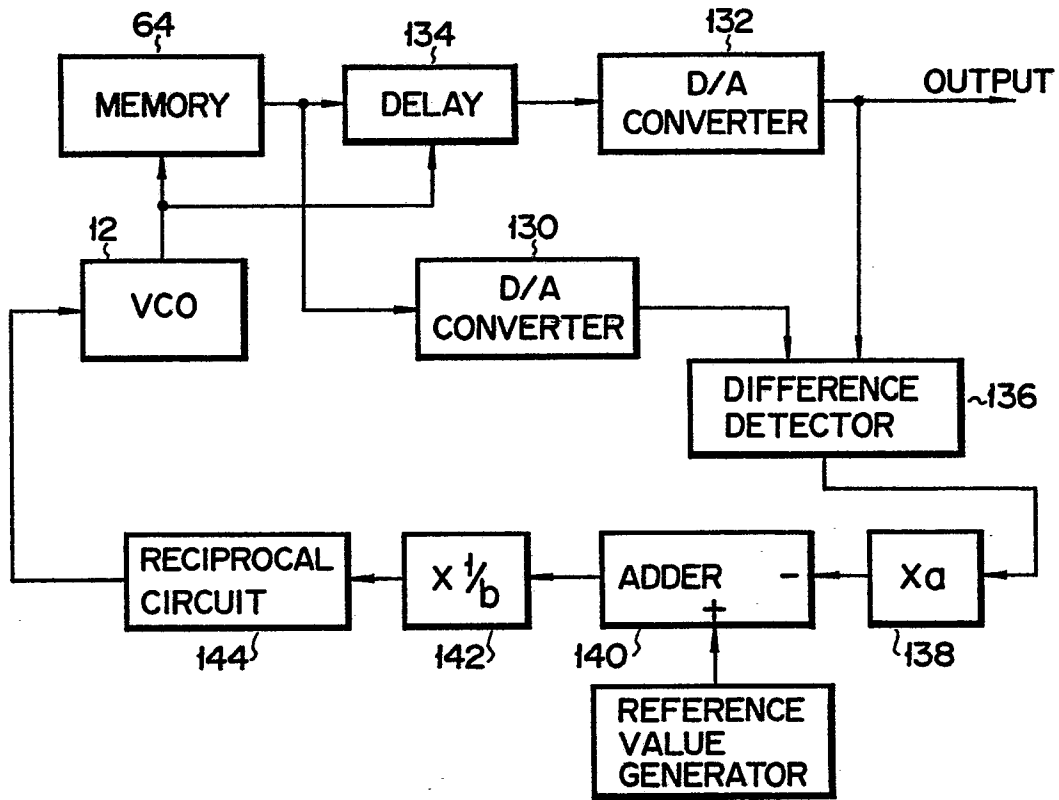

FIG. 16

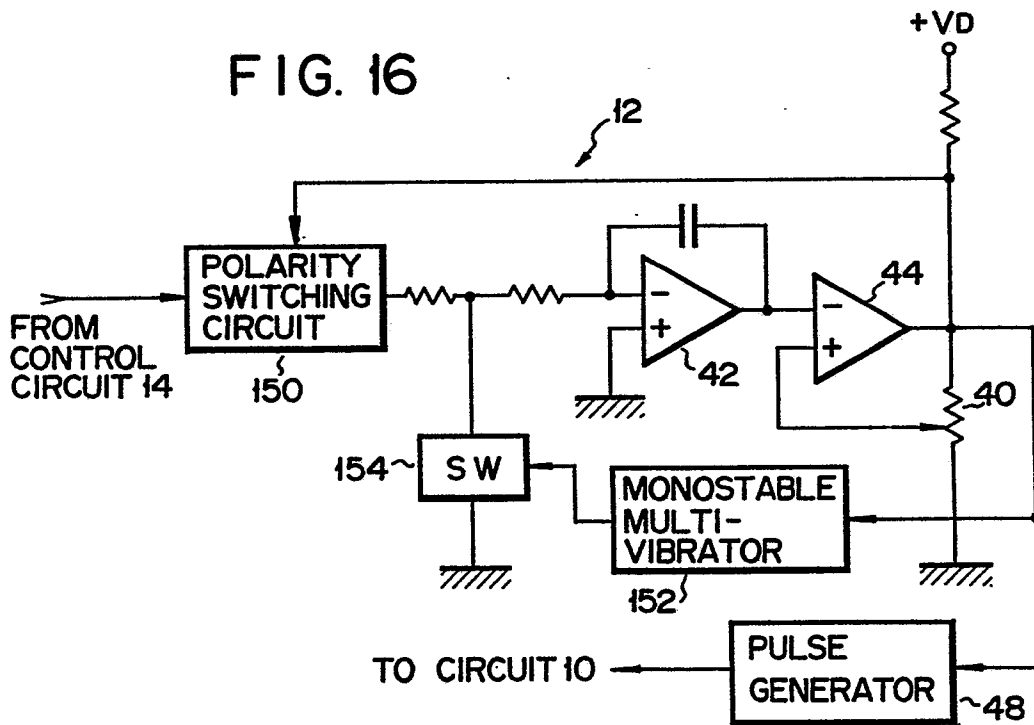

FIG. 17

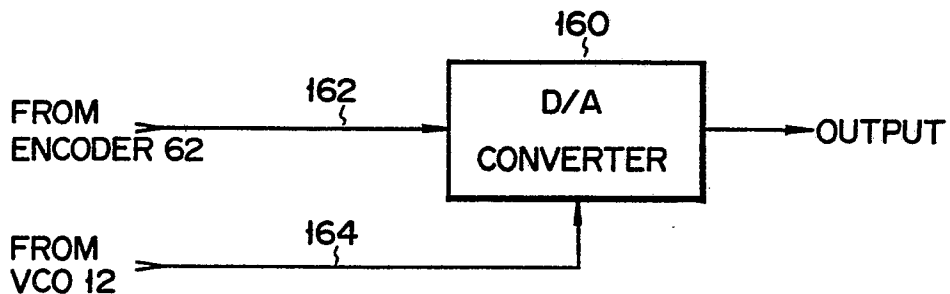

FIG. 18

