



(11) **EP 3 370 026 A1**

(12) **EUROPEAN PATENT APPLICATION**
published in accordance with Art. 153(4) EPC

(43) Date of publication:
05.09.2018 Bulletin 2018/36

(51) Int Cl.:
F28D 7/02 ^(2006.01) **F28F 1/36** ^(2006.01)
F28F 19/00 ^(2006.01) **F28F 19/04** ^(2006.01)
F28D 7/00 ^(2006.01)

(21) Application number: **17797221.3**

(22) Date of filing: **18.01.2017**

(86) International application number:
PCT/JP2017/001447

(87) International publication number:
WO 2018/134899 (26.07.2018 Gazette 2018/30)

(84) Designated Contracting States:
AL AT BE BG CH CY CZ DE DK EE ES FI FR GB GR HR HU IE IS IT LI LT LU LV MC MK MT NL NO PL PT RO RS SE SI SK SM TR
Designated Extension States:
BA ME
Designated Validation States:
MA MD

(72) Inventors:
• **YAMAGUCHI, Kosuke**
Tokyo 100-8310 (JP)
• **AZUMA, Masaaki**
Tokyo 100-8310 (JP)

(71) Applicant: **MITSUBISHI ELECTRIC CORPORATION**
Chiyoda-ku
Tokyo 100-8310 (JP)

(74) Representative: **Pfenning, Meinig & Partner mbB**
Patent- und Rechtsanwälte
Theresienhöhe 11a
80339 München (DE)

(54) **TWISTED PIPE HEAT EXCHANGER**

(57) A twisted tube heat exchanger includes a twisted tube, and a heat insulator. The twisted tube includes a first pipe having a spiral groove formed on a periphery of the first pipe and allowing a first fluid to flow through the first pipe, and a second pipe having a part wound around the spiral groove on the first pipe and allowing refrigerant that heats the first fluid to flow through the second pipe. An area in which the first pipe and the second pipe are joined together is defined as a first area,

and an area that is located closer to an end side of the first pipe than is the first area and in which the first pipe and the second pipe are not joined together is defined as a second area. The heat insulator is wound around a certain area including a boundary region between the first area and the second area, covering peripheries of the first pipe and the second pipe in the boundary region and a periphery of the first pipe in the second area.

FIG. 3

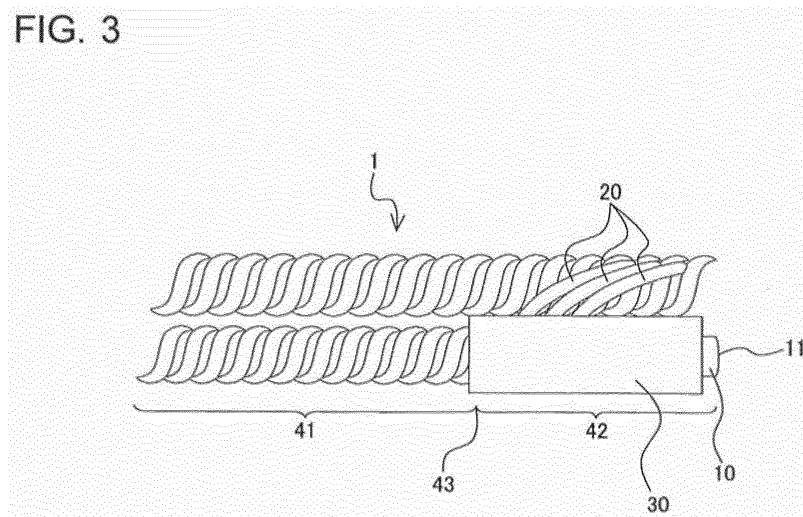

EP 3 370 026 A1

Description

Technical Field

[0001] The present invention relates to a twisted tube heat exchanger including a first pipe, and a second pipe installed spirally on a periphery of the first pipe.

Background Art

[0002] A heat exchanger has been known that includes a first pipe, and a second pipe installed on a periphery of the first pipe and in which a first fluid such as water flowing through the first pipe is heated by refrigerant flowing through the second pipe (see, for example, Patent Literature 1). In the heat exchanger described in Patent Literature 1, the second pipe is placed along a length direction of the first pipe. In other words, in the heat exchanger described in Patent Literature 1, the first pipe and the second pipe are arranged in parallel. Besides, in the heat exchanger described in Patent Literature 1, peripheries of the first pipe and the second pipe are covered with a resin layer and the second pipe is placed in close contact with the first pipe. The resin layer covering the peripheries of the first pipe and the second pipe also serves as a heat insulator. Also, the resin layer is provided on the peripheries of the first pipe and the second pipe by extrusion process.

[0003] Also, as a heat exchanger configured to heat the first fluid such as water flowing through the first pipe with refrigerant flowing through the second pipe, a twisted tube heat exchanger has been proposed. The twisted tube heat exchanger includes a first pipe with a spiral groove formed on a periphery and a second pipe wound around the groove on the first pipe. That is, the second pipe is installed spirally on the periphery of the first pipe.

Citation List

Patent Literature

[0004] Patent Literature 1: Japanese Unexamined Patent Application Publication No. 2004-347178

Summary of Invention

Technical Problem

[0005] In the heat exchanger described in Patent Literature 1, the resin layer serving as a heat insulator is formed by extrusion process. That is, the heat exchanger described in Patent Literature 1 is configured such that the heat insulator is installed on the entire heat exchanger. Thus, a configuration in which a heat insulator is installed in such a way as described in Patent Literature 1 has a problem of increased material costs of the heat exchanger.

[0006] Also, the twisted tube heat exchanger has a

complicated shape in which the second pipe is installed spirally on the periphery of the first pipe. Consequently, it is practically impossible to form a resin layer on the peripheries of the twisted tube heat exchanger by extrusion process. Thus, the conventional twisted tube heat exchanger has a problem in that the second pipe is corroded because a heat insulating layer cannot be formed on the peripheries.

[0007] Specifically, opposite ends of the second pipe are connected with a pipe used to supply refrigerant to the second pipe and a pipe through which the refrigerant flows out of the second pipe, and thus are not wound around the periphery of the first pipe. Consequently, a mid-portion of the second pipe is wound around a periphery of a mid-portion of the first pipe. Then, the part of the second pipe that is wound around the periphery of the first pipe is joined to the first pipe by soldering or another joining method. Hereinafter, an area in which the first pipe and the second pipe are joined together will be referred to as a first area while an area that is located closer to an end side of the first pipe than is the first area and an area in which the first pipe and the second pipe are not joined together will be referred to as a second area.

[0008] In the twisted tube heat exchanger, which is configured as described above, the first fluid flowing into the first pipe flows first in the second area. Subsequently, the first fluid in the first pipe flows into the first area and is heated by the refrigerant flowing through the second pipe. That is, the first fluid flowing through a section of the first pipe that is located in the second area is yet to be heated by the refrigerant, and thus remains at a low temperature. Consequently, the section of the first pipe that is located in the second area is at a lower temperature than ambient temperature and tends to cause condensation. Also, in the second area, in which the first pipe and the second pipe are not joined together, a gap is formed between the first pipe and the second pipe. Consequently, when condensation occurs, in the second area in which the gap between the first pipe and the second pipe is small, that is, in a part of the second area that is close to a border with the first area, condensed water is held, bridging between the first pipe and the second pipe. Here, the refrigerant higher in temperature than the first fluid flows through the second pipe to heat the first fluid in the first pipe. That is, the second pipe is higher in temperature than the first pipe. Consequently, when condensed water is held, bridging between the first pipe and the second pipe, the bridging portion acts as a thermogalvanic cell, causing corrosion of the second pipe located on a high temperature side.

[0009] The present invention has been made to solve the above problem and has an object to provide a twisted tube heat exchanger that can inhibit corrosion of the second pipe and curb increases in material costs.

Solution to Problem

[0010] A twisted tube heat exchanger according to an embodiment of the present invention includes a twisted tube, and a heat insulator. The twisted tube includes a first pipe having a spiral groove formed on a periphery of the first pipe and allowing a first fluid to flow through the first pipe, and a second pipe having a part wound around the spiral groove on the first pipe and allowing refrigerant that heats the first fluid to flow through the second pipe. An area in which the first pipe and the second pipe are joined together is defined as a first area, and an area that is located closer to an end side of the first pipe than is the first area and in which the first pipe and the second pipe are not joined together is defined as a second area. The heat insulator is wound around a certain area including a boundary region between the first area and the second area, covering peripheries of the first pipe and the second pipe in the boundary region and a periphery of the first pipe in the second area.

Advantageous Effects of Invention

[0011] The twisted tube heat exchanger according to an embodiment of the present invention can be used as a configuration in which the first fluid flows from the second area to the first area. In the twisted tube heat exchanger according to the embodiment of the present invention, the heat insulator is wound, covering the peripheries of the first pipe and the second pipe in the boundary region between the first area and the second area as well as the periphery of the first pipe in the second area. That is, in the twisted tube heat exchanger according to the embodiment of the present invention, the heat insulator is wound around a portion in which condensed water bridging between the first pipe and the second pipe acts as a thermogalvanic cell, causing corrosion of the second pipe. Unlike a heat insulator installation method that uses an extrusion process, a heat insulator installation method of winding a heat insulator can easily install the heat insulator even on the twisted tube heat exchanger that has a complicated shape. Consequently, the twisted tube heat exchanger according to the embodiment of the present invention can inhibit condensed water from bridging between the first pipe and the second pipe and inhibit the bridging portion from acting as a thermogalvanic cell and causing corrosion of the second pipe. Also, the twisted tube heat exchanger according to the embodiment of the present invention, only in a part of which the heat insulator is installed, can curb increases in material costs of the twisted tube heat exchanger.

Brief Description of Drawings

[0012]

[Fig. 1] Fig. 1 is a perspective view showing a twisted tube heat exchanger according to an embodiment

of the present invention.

[Fig. 2] Fig. 2 is an enlarged view of a principal part showing a vicinity of a heat insulator installation area of a twisted tube in the twisted tube heat exchanger according to the embodiment of the present invention, where a heat insulator is yet to be installed.

[Fig. 3] Fig. 3 is an enlarged view of a principal part showing a vicinity of the heat insulator installation area of the twisted tube in the twisted tube heat exchanger according to the embodiment of the present invention, where a heat insulator has been installed.

[Fig. 4] Fig. 4 is a sectional view of the heat insulator installation area of the twisted tube in the twisted tube heat exchanger according to the embodiment of the present invention.

[Fig. 5] Fig. 5 is a diagram showing an example of the heat insulator wound around the twisted tube of the twisted tube heat exchanger according to the embodiment of the present invention.

[Fig. 6] Fig. 6 is a diagram showing another example of the heat insulator wound around the twisted tube of the twisted tube heat exchanger according to the embodiment of the present invention.

25 Description of Embodiments

Embodiment

[0013] Fig. 1 is a perspective view showing a twisted tube heat exchanger according to an embodiment of the present invention.

[0014] The twisted tube heat exchanger 100 includes a twisted tube 1. Although details of the twisted tube 1 will be described later, the twisted tube 1 includes a first pipe 10 through which a first fluid such as water flows and second pipes 20 through which refrigerant that heats the first fluid flows, as described later (see Figs. 2 and 3 described later). Also, in the twisted tube heat exchanger 100 according to the present embodiment, a heat insulator 30 is wound around a part of the twisted tube 1. Note that the twisted tube heat exchanger 100 according to the present embodiment uses a long twisted tube 1 (long in length). Consequently, in the twisted tube heat exchanger 100 according to the present embodiment, the twisted tube 1 is wound into a coil shape having a plurality of turns. A height of the coil shape portion and the number of the turns of the coil shape portion can be determined appropriately depending on a length of the twisted tube 1.

[0015] The twisted tube heat exchanger 100 is used, for example, as a water refrigerant heat exchanger for a heat pump water heater. In this case, water serving as the first fluid is heated by the twisted tube heat exchanger 100. Specifically, the water flows into the twisted tube 1 through an inlet-side end portion 11 of the twisted tube 1. More specifically, the water flows into the first pipe 10 through the inlet-side end portion 11 of the first pipe 10 of the twisted tube 1. Then, the water flowing into the first

pipe 10 is heated to become hot water by the refrigerant flowing through the second pipes 20, and then flows out through an outlet-side end portion 12.

[0016] Next, details of the twisted tube 1 according to the present embodiment will be described.

[0017] Fig. 2 is an enlarged view of a principal part showing a vicinity of a heat insulator installation area of the twisted tube in the twisted tube heat exchanger according to the embodiment of the present invention, where a heat insulator is yet to be installed. Fig. 3 is an enlarged view of a principal part showing a vicinity of the heat insulator installation area of the twisted tube in the twisted tube heat exchanger according to the embodiment of the present invention, where a heat insulator has been installed. Also, Fig. 4 is a sectional view of the heat insulator installation area of the twisted tube in the twisted tube heat exchanger according to the embodiment of the present invention. Note that Fig. 4 is a sectional view perpendicular to a length direction of the first pipe 10. In other words, Fig. 4 is a sectional view perpendicular to a pipe axis direction of the first pipe 10. Also, Fig. 4 is a sectional view of a location at which the first pipe 10 and the second pipes 20 are joined together.

[0018] The twisted tube 1 includes the first pipe 10 and the second pipes 20 installed spirally on a periphery of the first pipe 10. The first pipe 10 and the second pipes 20 are formed of a material having good thermal conductivity. According to the present embodiment, the first pipe 10 and the second pipes 20 are formed, for example, of copper or a copper alloy.

[0019] As described above, the first pipe 10 allows the first fluid such as water to flow through the first pipe 10. Spiral grooves 13 are formed on the periphery of the first pipe 10, allowing the second pipes 20 to be wound around the spiral grooves 13. Specifically, according to the present embodiment, spiral ridges 14 and spiral valleys 15 are formed alternately on the periphery of the first pipe 10. The valleys 15 serve as the grooves 13. Note that plural grooves 13 are formed according to the present embodiment. More specifically, three grooves 13 are formed according to the present embodiment. Consequently, as shown in Fig. 4, a cross-sectional shape of the first pipe 10 having the grooves 13 is triangular. This is because three sides are formed when the first pipe 10 is formed by twisting a circular pipe to form three grooves around the first pipe 10. Consequently, when four grooves 13 are formed on the first pipe 10, a cross-sectional shape of the first pipe 10 having the grooves 13 is quadrangular.

[0020] As described above, the second pipes 20 allow the refrigerant that heats the first fluid to flow through the second pipes 20. The second pipes 20 are wound around the grooves 13 on the first pipe 10. Note that plural grooves 13 (more specifically, three grooves 13) are formed according to the present embodiment as described above. Consequently, as many second pipes 20 as grooves are formed are wound around the periphery of the first pipe 10.

[0021] Opposite ends of the second pipes 20 are connected with a pipe used to supply the refrigerant to the second pipes 20 and a pipe through which the refrigerant flows out of the second pipes 20, and thus are not wound around the periphery of the first pipe 10. Consequently, mid-portions of the second pipes 20, that is, parts of the second pipes 20, are wound around a periphery (that is, the grooves 13) of a mid-portion of the first pipe 10. Then, the parts of the second pipes 20 that are wound around the grooves 13 on the first pipe 10 are joined to the first pipe 10 by soldering or another joining method.

[0022] Note that, according to the present embodiment, an area in which the first pipe 10 and the second pipes 20 are joined together is defined as a first area 41. Also, an area that is located closer to the inlet-side end portion 11 of the first pipe 10 than is the first area 41 and in which the first pipe 10 and the second pipes 20 are not joined together is defined as a second area 42. Also, a boundary region between the first area 41 and the second area 42 is defined as a boundary region 43. That is, the boundary region 43 is an outermost portion of the area in which the first pipe 10 and the second pipes 20 are joined together.

[0023] As shown in Fig. 3, in the twisted tube 1 according to the present embodiment, the above-mentioned heat insulator 30 is installed in a certain area including the boundary region 43. Specifically, the heat insulator 30 is wound, covering peripheries of the first pipe 10 and the second pipes 20 in the boundary region 43 and the periphery of the first pipe 10 in the second area 42. Note that length of the heat insulator 30 (specifically, axial length of the twisted tube 1) is not particularly limited, but when ease of winding operation, cost of the heat insulator 30, length of an area in which condensation of the twisted tube 1 is expected, and similar other factors are taken into consideration, an appropriate length of the heat insulator 30 is approximately 20 cm from the boundary region 43 toward the second area 42. Also, preferably the heat insulator 30 is formed of a material from which components tending to corrode the first pipe 10 or the second pipes 20 are less liable to leach out, for example, of polyethylene foam resin.

[0024] The heat insulator 30 is fixed by being stuck to the twisted tube 1 by adhesive, with the adhesive being applied, for example, to an entire area on one side of the heat insulator 30. When the heat insulator 30 is fixed in this way, regarding the adhesive to be used, it is advisable to avoid adhesives from which any component (hydrochloric acid, sulfuric acid, acetic acid, or another similar acid) tending to corrode the first pipe 10 or the second pipes 20 leaches out, and, for example, an acrylic adhesive is desirable.

[0025] Fig. 5 is a diagram showing an example of the heat insulator wound around the twisted tube of the twisted tube heat exchanger according to the embodiment of the present invention. Also, Fig. 6 is a diagram showing another example of the heat insulator wound around the twisted tube of the twisted tube heat exchanger according

to the embodiment of the present invention.

[0026] Before being wound around the twisted tube 1, the heat insulator 30 has, for example, a rectangular shape and has as many holes 31 as second pipes 20 are formed. The holes 31 are holes through which the second pipes 20 are inserted. The holes 31 have a diameter, for example, substantially equal to an outside diameter of the second pipes 20. Note that locations of the holes 31 are not particularly limited, but the holes 31 are formed at an approximate center location in a short-side direction. Also, preferably a length L2 of a short side of the heat insulator 30 is dimensioned such that almost the entire peripheries of the first pipe 10 and the second pipes 20 in the boundary region 43 can be covered (see Fig. 4). Also, according to the present embodiment, as shown in Fig. 3, an end of the heat insulator 30 in a longitudinal direction is placed in the vicinity of a boundary region 43. Consequently, when the area of approximately 20 cm from the boundary region 43 toward the second area 42 is covered by the heat insulator 30, preferably a length L1 of the long side of the heat insulator 30 is also approximately 20 cm. Note that, when a part of the first area 41 closer to the boundary region 43 is also covered by the heat insulator 30, it is advisable to extend the length L1 of the heat insulator 30 by a length over which of the part of the first area 41 is covered.

[0027] Also, a cut is made in the heat insulator 30, running from each hole 31 to an end of the heat insulator 30. When the second pipes 20 are inserted into the holes 31, by inserting the second pipes 20 from the end of the heat insulator 30 through the cuts 32, the second pipes 20 can be inserted easily into the holes 31. Note that a formation direction of the cuts 32 is not particularly limited. The cuts 32 may be made toward a long side as shown in Fig. 5 or the cut 32 may be made toward a short side as shown in Fig. 6.

[0028] Next, an operation of heating the first fluid in the twisted tube heat exchanger 100 according to the present embodiment will be described.

[0029] The first fluid flows into the first pipe 10 through the inlet-side end portion 11 of the first pipe 10 of the twisted tube 1. The first fluid flows in the first pipe 10 from the second area 42 toward the first area 41. Then, while flowing through the first area 41, the first fluid is heated by the refrigerant flowing through the second pipes 20. The heated first fluid flows out of the twisted tube heat exchanger 100 through the outlet-side end portion 12 of the first pipe 10.

[0030] Here, the first fluid flowing through a section of the first pipe 10 that is located in the second area 42 is yet to be heated by the refrigerant, and is the coldest of the first fluid in the first pipe 10. Consequently, the section of the first pipe that is located in the second area is at a lower temperature than ambient temperature, creating an environment liable to cause condensation. Consequently, when the twisted tube heat exchanger 100 is not provided with a heat insulator 30, the section of the first pipe that is located in the second area may cause con-

densation.

[0031] The second area 42 is an area in which the first pipe 10 and the second pipes 20 are not joined together, and a gap 2 is formed between the first pipe 10 and the second pipes 20 (see Fig. 2). Consequently, when the section of the first pipe that is located in the second area causes condensation, in a part of the second area 42 that is close to the boundary region 43 in which the gap 2 is small, condensed water is held, acting as a bridge. Here, the refrigerant higher in temperature than the first fluid flows through the second pipes 20 to heat the first fluid in the first pipe 10. That is, the second pipes 20 are higher in temperature than the first pipe 10. Consequently, when condensed water is held, bridging between the first pipe 10 and the second pipes 20, the bridging portion acts as a thermogalvanic cell, causing corrosion of the second pipes 20 located on a high temperature side.

[0032] However, in the twisted tube heat exchanger 100 according to the present embodiment, the heat insulator 30 is wound around a certain area including the boundary region 43. That is, in the twisted tube heat exchanger 100, the heat insulator 30 is wound around the part in which the condensed water bridging between the first pipe 10 and the second pipes 20 would cause corrosion of the second pipes 20 by acting as a thermogalvanic cell. Consequently, the twisted tube heat exchanger 100 according to the present embodiment can inhibit the certain area including the boundary region 43 from cooling ambient air, that is, inhibit the certain area including the boundary region 43 from causing condensation. Thus, the twisted tube heat exchanger 100 according to the present embodiment can inhibit corrosion of the second pipes 20.

[0033] Note that, as described above, in the twisted tube heat exchanger 100 according to the present embodiment, the twisted tube 1 is wound into a coil shape having a plurality of turns. Consequently, when the twisted tube heat exchanger 100 is not provided the heat insulator 30, condensed water is likely to bridge between the section of the first pipe 10 that is located in the second area 42 and a section of the twisted tube 1 that is located above this section. When condensed water acts as a bridge in this way, the bridging portion acts as a thermogalvanic cell, causing corrosion of the second pipe 20 located on the high temperature side. However, as shown in Figs. 1 and 3, in the twisted tube heat exchanger 100 according to the present embodiment, the heat insulator 30 is placed between the area in which the heat insulator 30 is wound and the section of the twisted tube 1 that is located above this area. Thus, the twisted tube heat exchanger 100 according to the present embodiment can inhibit corrosion of the second pipes 20 in the first area 41.

[0034] As described above, the twisted tube heat exchanger 100 according to the present embodiment includes the twisted tube 1, the twisted tube 1 including the first pipe 10 having spiral grooves 13 formed on a periphery of the first pipe 10 and allowing a first fluid to flow through the first pipe 10, and the second pipes 20

having a part wound around the grooves 13 on the first pipe 10 and allowing refrigerant that heats the first fluid to flow through the second pipes 20. Also, the twisted tube heat exchanger 100 according to the present embodiment includes the heat insulator 30 wound around a certain area including the boundary region 43 between the first area 41 and the second area 42, covering the peripheries of the first pipe 10 and the second pipes 20 in the boundary region 43 and the periphery of the first pipe 10 in the second area 42.

[0035] In the twisted tube heat exchanger 100 according to the present embodiment, the heat insulator 30 is wound around the part in which the condensed water bridging between the first pipe 10 and the second pipes 20 would cause corrosion of the second pipes 20 by acting as a thermogalvanic cell. Unlike a heat insulator installation method that uses an extrusion process, a heat insulator installation method of winding the heat insulator 30 can easily install the heat insulator 30 even on the twisted tube heat exchanger 100 that has a complicated shape. Consequently, the twisted tube heat exchanger 100 according to the present embodiment can inhibit condensed water from bridging between the first pipe 10 and the second pipes 20 and inhibit the bridging portion from acting as a thermogalvanic cell and causing corrosion of the second pipes 20. Also, the twisted tube heat exchanger 100 according to the present embodiment, only in a part of which the heat insulator 30 is installed, can curb increases in material costs of the twisted tube heat exchanger 100.

[0036] Note that the heat insulator 30 is formed, for example, of polyethylene foam resin. This is because polyethylene foam resin is material from which components tending to corrode the first pipe 10 or the second pipes 20 are less liable to leach out.

[0037] Also, the holes 31 through which the second pipes 20 are inserted and cuts 32 running from the holes 31 to an end of the heat insulator 30 are made in the heat insulator 30, for example. When the second pipes 20 are inserted into the holes 31, by inserting the second pipes 20 from the end of the heat insulator 30 through the cuts 32, the second pipes 20 can be inserted easily into the holes 31. That is, the heat insulator 30 can be installed more easily.

[0038] Also, when the twisted tube 1 is wound into a coil shape having a plurality of turns, the heat insulator 30 is placed between the certain area (around which the heat insulator 30 is wound) and a section of the twisted tube 1 that is located above the certain area. Corrosion of the second pipes 20 can also be inhibited in the section of the twisted tube 1 that is located above the certain area (around which the heat insulator 30 is wound).

Reference Signs List

[0039]

1 twisted tube 2 gap 10 first pipe 11 inlet-side end

portion 12 outlet-side end portion 13 groove 14 ridge 15 valley 20 second pipe 30 heat insulator 31 hole 32 cut 41 first area 42 second area 43 boundary region 100 twisted tube heat exchanger

5

Claims

10

1. A twisted tube heat exchanger comprising:

a twisted tube; and
a heat insulator,
the twisted tube including

15

a first pipe having a spiral groove formed on a periphery of the first pipe and allowing a first fluid to flow through the first pipe, and a second pipe having a part wound around the spiral groove on the first pipe and allowing refrigerant that heats the first fluid to flow through the second pipe,

20

an area in which the first pipe and the second pipe are joined together being defined as a first area,

25

an area that is located closer to an end side of the first pipe than is the first area and in which the first pipe and the second pipe are not joined together being defined as a second area,

30

the heat insulator being wound around a certain area including a boundary region between the first area and the second area, covering peripheries of the first pipe and the second pipe in the boundary region and a periphery of the first pipe in the second area.

35

2. The twisted tube heat exchanger of claim 1, wherein the heat insulator is formed of polyethylene foam resin.

40

3. The twisted tube heat exchanger of claim 1 or 2, wherein a hole through which the second pipe is inserted and a cut running from the hole to an end of the heat insulator are made in the heat insulator.

45

4. The twisted tube heat exchanger of any one of claims 1 to 3, wherein the twisted tube is wound into a coil shape having a plurality of turns, and the heat insulator is placed between the certain area and a section of the twisted tube that is located above the certain area.

50

5. The twisted tube heat exchanger of any one of claims 1 to 4, wherein the first fluid flows from the second area toward the first area.

55

FIG. 1

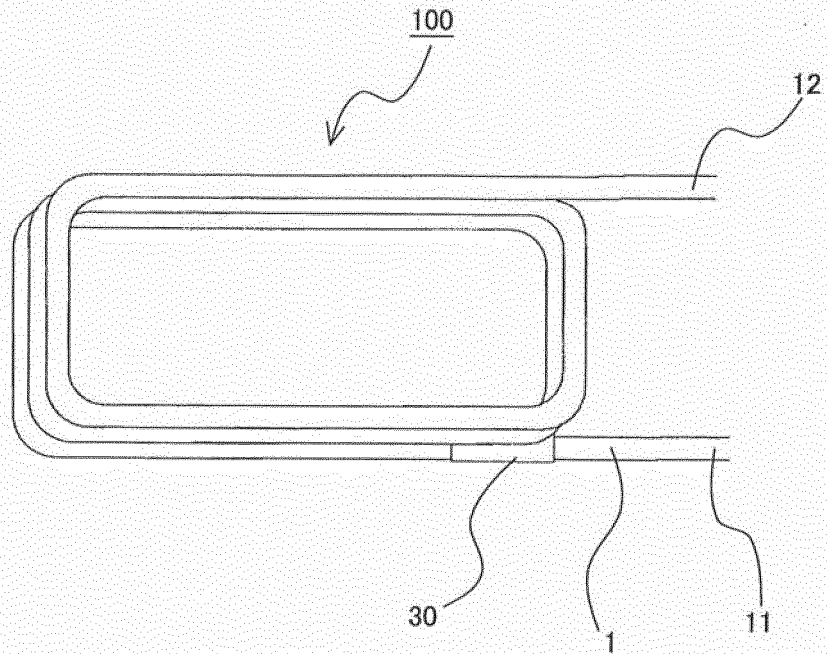

FIG. 2

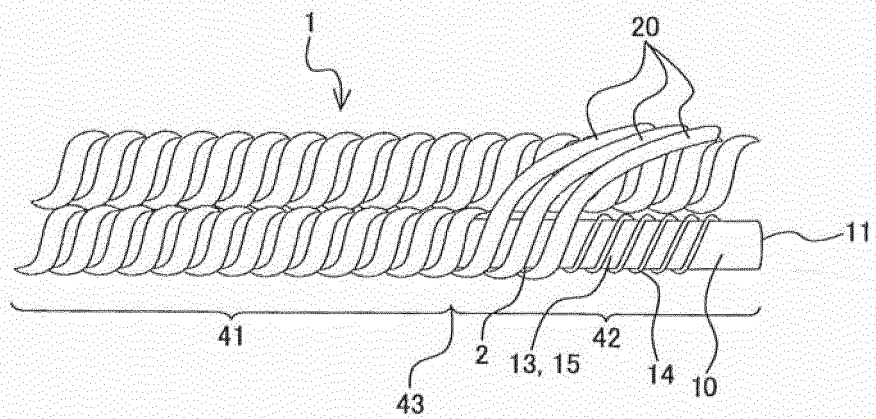

FIG. 3

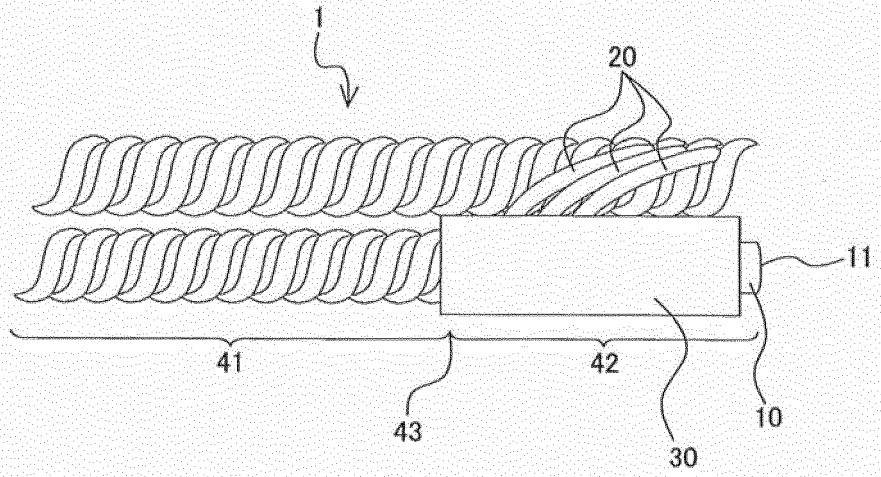

FIG. 4

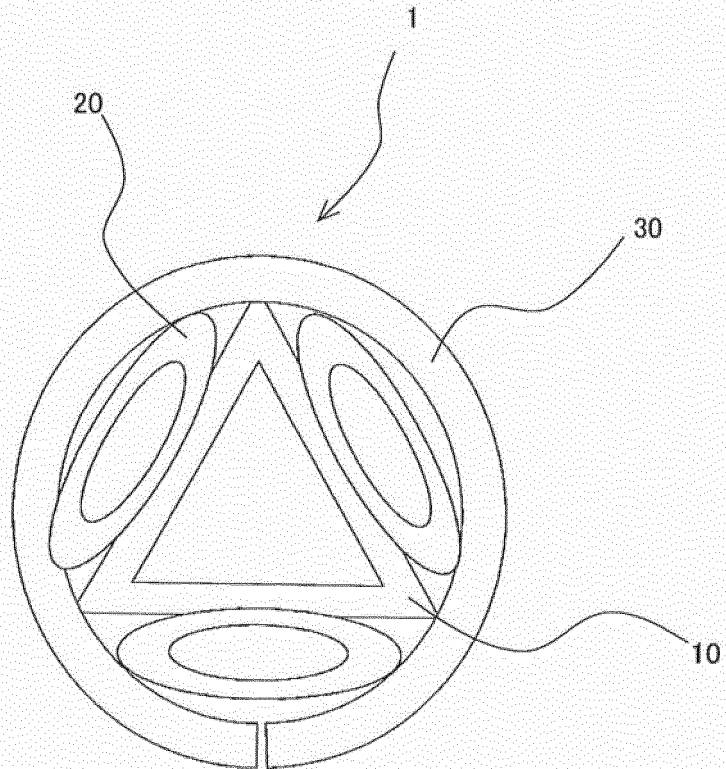

FIG. 5

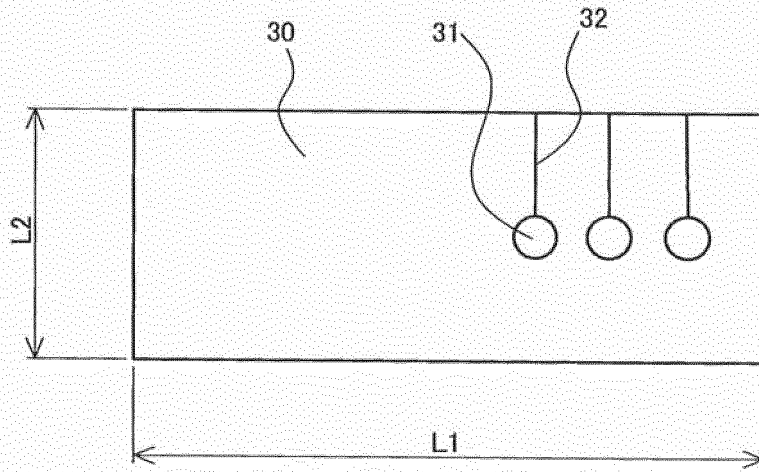
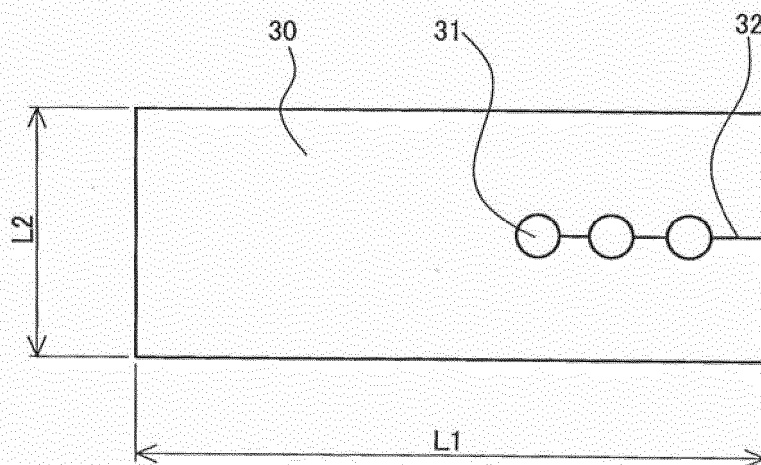

FIG. 6



INTERNATIONAL SEARCH REPORT

International application No.

PCT/JP2017/001447

5	A. CLASSIFICATION OF SUBJECT MATTER <i>F28D7/02</i> (2006.01)i, <i>F28F1/36</i> (2006.01)i, <i>F28F19/00</i> (2006.01)i, <i>F28F19/04</i> (2006.01)i According to International Patent Classification (IPC) or to both national classification and IPC		
10	B. FIELDS SEARCHED Minimum documentation searched (classification system followed by classification symbols) <i>F28D7/02</i> , <i>F28F1/36</i> , <i>F28F19/00</i> , <i>F28F19/04</i> Documentation searched other than minimum documentation to the extent that such documents are included in the fields searched Jitsuyo Shinan Koho 1922-1996 Jitsuyo Shinan Toroku Koho 1996-2017 Kokai Jitsuyo Shinan Koho 1971-2017 Toroku Jitsuyo Shinan Koho 1994-2017 Electronic data base consulted during the international search (name of data base and, where practicable, search terms used)		
15			
20	C. DOCUMENTS CONSIDERED TO BE RELEVANT		
	Category*	Citation of document, with indication, where appropriate, of the relevant passages	Relevant to claim No.
25	A	JP 2008-96043 A (Mitsubishi Electric Corp.), 24 April 2008 (24.04.2008), paragraphs [0017], [0020], [0036]; fig. 3 (Family: none)	1-5
30	A	Microfilm of the specification and drawings annexed to the request of Japanese Utility Model Application No. 125671/1985 (Laid-open No. 34662/1987) (Tokyo Gas Co., Ltd.), 28 February 1987 (28.02.1987), drawings (Family: none)	1-5
35			
40	<input checked="" type="checkbox"/> Further documents are listed in the continuation of Box C.		<input type="checkbox"/> See patent family annex.
45	* Special categories of cited documents: "A" document defining the general state of the art which is not considered to be of particular relevance "E" earlier application or patent but published on or after the international filing date "L" document which may throw doubts on priority claim(s) or which is cited to establish the publication date of another citation or other special reason (as specified) "O" document referring to an oral disclosure, use, exhibition or other means "P" document published prior to the international filing date but later than the priority date claimed		"T" later document published after the international filing date or priority date and not in conflict with the application but cited to understand the principle or theory underlying the invention "X" document of particular relevance; the claimed invention cannot be considered novel or cannot be considered to involve an inventive step when the document is taken alone "Y" document of particular relevance; the claimed invention cannot be considered to involve an inventive step when the document is combined with one or more other such documents, such combination being obvious to a person skilled in the art "&" document member of the same patent family
50	Date of the actual completion of the international search 17 March 2017 (17.03.17)		Date of mailing of the international search report 28 March 2017 (28.03.17)
55	Name and mailing address of the ISA/ Japan Patent Office 3-4-3, Kasumigaseki, Chiyoda-ku, Tokyo 100-8915, Japan		Authorized officer Telephone No.

Form PCT/ISA/210 (second sheet) (January 2015)

INTERNATIONAL SEARCH REPORT

International application No.

PCT/JP2017/001447

C (Continuation). DOCUMENTS CONSIDERED TO BE RELEVANT

Category*	Citation of document, with indication, where appropriate, of the relevant passages	Relevant to claim No.
A	Microfilm of the specification and drawings annexed to the request of Japanese Utility Model Application No. 162105/1980 (Laid-open No. 24870/1982) (Takaaki ABE), 09 February 1982 (09.02.1982), fig. 2 (Family: none)	1-5
A	Microfilm of the specification and drawings annexed to the request of Japanese Utility Model Application No. 163677/1978 (Laid-open No. 80685/1980) (Yuko OIKAWA), 03 June 1980 (03.06.1980), drawings (Family: none)	1-5
A	JP 2009-2631 A (The Furukawa Electric Co., Ltd.), 08 January 2009 (08.01.2009), fig. 6 (Family: none)	1-5

REFERENCES CITED IN THE DESCRIPTION

This list of references cited by the applicant is for the reader's convenience only. It does not form part of the European patent document. Even though great care has been taken in compiling the references, errors or omissions cannot be excluded and the EPO disclaims all liability in this regard.

Patent documents cited in the description

- JP 2004347178 A [0004]