

Feb. 11, 1936.

J. WARET

2,030,162

HEATING BLOCK FOR THE TREATMENT OF HAIR

Filed June 9, 1934

2 Sheets-Sheet 1

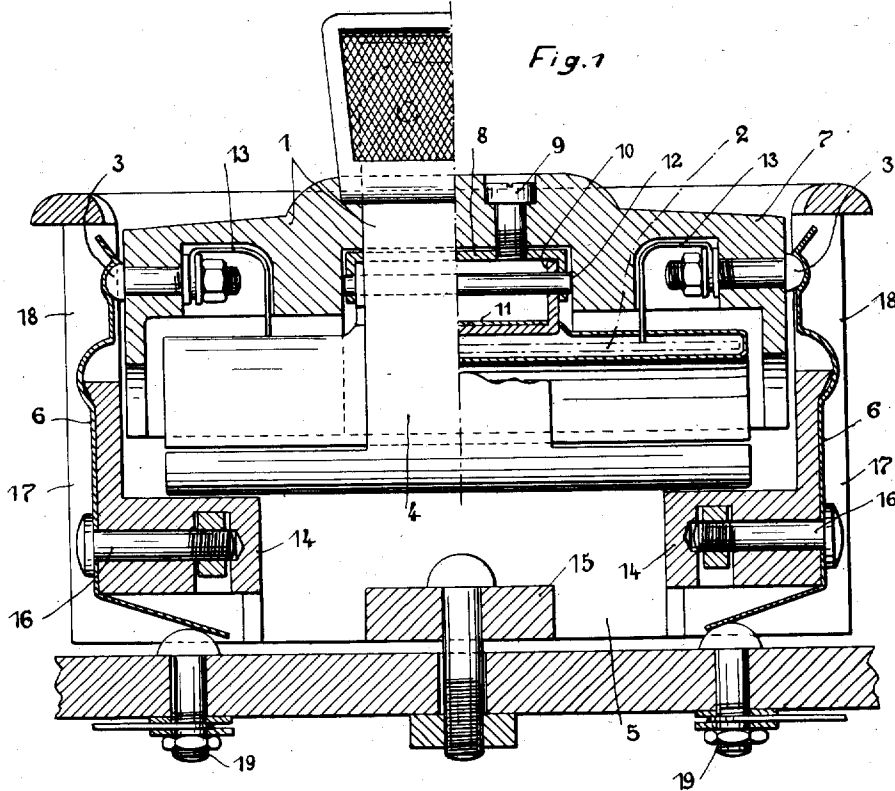

Fig. 1

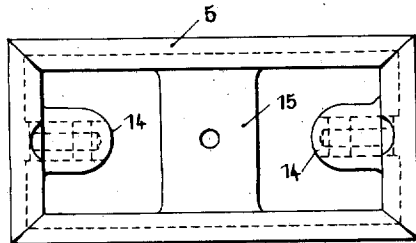

Fig. 4.

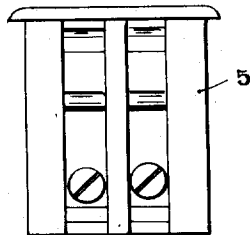

Fig. 5.

INVENTOR
JULIEN WARET

BY

Richardson & Coier

ATTORNEYS

Feb. 11, 1936.

J. WARET

2,030,162

HEATING BLOCK FOR THE TREATMENT OF HAIR

Filed June 9, 1934

2 Sheets-Sheet 2

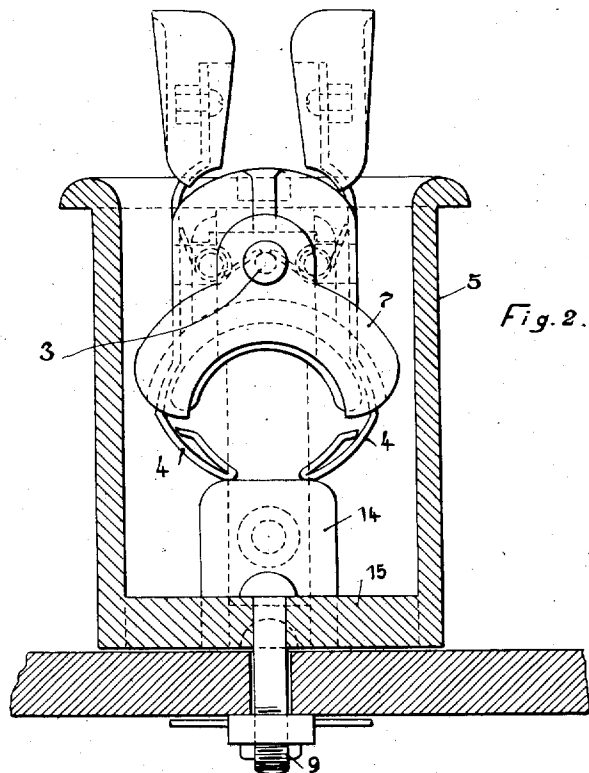

Fig. 2.

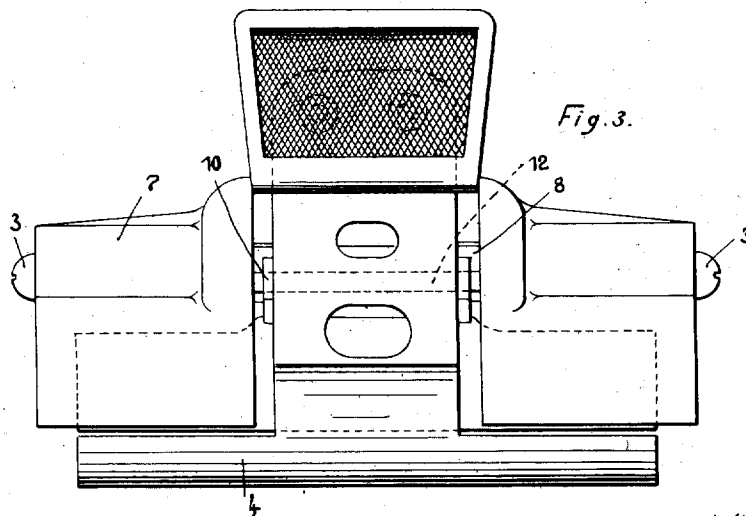

Fig. 3.

INVENTOR
JULIEN WARET
BY
Richardson & Green
ATTORNEYS

UNITED STATES PATENT OFFICE

2,030,162

HEATING BLOCK FOR THE TREATMENT OF HAIR

Julien Waret, Vincennes, France

Application June 9, 1934, Serial No. 729,809
In France January 29, 1934

4 Claims. (Cl. 219—24)

The present invention has for its object to provide a heating block to make a so called permanent hair treatment, and including a heat accumulator with its electric junction box.

5 The heat accumulator consists of pliers with contacts at their opposite ends extending in the longitudinal direction of the heating element, in order that the pliers may be heated by a current feed brought to a junction box, and thus avoiding the feeding by loose wires together with the ceiling shaped apparatus.

10 The junction box is fixed on a moveable support bearing a plurality of similar connections. The said junction box leads the current to the contacts of the heater through spangles extending in the longitudinal direction, vertically from the lower up to the upper part in front of notches allowing the required resiliency for both the introduction and removal of the heater.

15 The contacting plots are arranged transversally on the spring arms. The junction box is provided with spangles for the current which is supplied to two opposite points in the transversal direction and in such a way that the resiliency of the pliers arms is used to keep up the plots against the spangles.

In the drawings:

Fig. 1 shows at enlarged scale the heating block in which the junction box is represented in section, and the heater partially in elevation and partially in section.

Fig. 2 is a transversal section of the heating block with a side view of the heater.

Fig. 3 shows in elevation the heater alone.

Fig. 4 is a plan view of the junction box.

Fig. 5 is an end view of an alternative junction box.

According to the invention, the heating block is made up of: (1) the heater or heat accumulator together with its heating resistance 2, its contacts 3 opposed to one another in the longitudinal direction and the spring pliers 4; (2) the junction box including an insulating socket 5 with its current leading spangles or contacts 6.

In the heat accumulator, 7 is the insulating member, 8 a stirrup fastened to the said member by screws 9, and 10 another stirrup bearing the heater 1 by means of a bridge 11. The stirrups 8 and 10 are connected by a pin 12.

The contacts or plots 3 arranged to the ends of the insulating member are connected to the resistance 2 by conductors 13.

In the junction box, 14 are bosses on which rests the accumulator after same is introduced, 15 is a small bar designed to fasten the socket to

the collecting support of junction boxes. The spangles 6 are fixed by screws 16 and extend along the whole height of the box into a recess 17. The upper part of the spangles is brought in front of openings 18 so as to get a certain resiliency under the pressure of the projecting contacts 3. The lower part is free and bent so as to provide a spring and come in contact with the wire sockets 19.

The combination of the heating block is a valuable improvement in the use of the pliers for permanent hair treatment.

It shows the following advantages:

(1) Owing to the system of movable contact the leading wires are eliminated which up to now have connected the heat accumulators to the supply of electric current.

(2) Every freedom of movement is given to perform the work owing to the absence of electric wires on the head of the person under treatment.

(3) It is possible to build devices requiring only a very small place and easily movable.

(4) Every risk of a defective handling is removed, the electric current of the accumulator being automatically broken off when an accumulator is to be used.

As above mentioned, both the heater and junction box may have plots arranged in the longitudinal as well as in the transversal direction. According to Fig. 5, it is provided that the bipolar junction box has its poles on a single side, same being arranged near one another.

Having now described the object of this invention and in which manner same is to be performed, what I claim is:

1. A heating block made of two parts for the treatment of hair, the first of said parts comprising pliers, an insulated member, said pliers being articulated upon said insulated member, an electrical resistance carried by said insulated member, contacts carried by said insulated member, and means operatively connecting said contacts with said electrical resistance, the second of said parts comprising a junction box having terminals receiving an electrical current and resilient spangles which are in contact with said terminals and with said contacts, said junction box being adapted to receive the first of said parts and closely surround the same, whereby the loss of heat is substantially reduced.

2. A heating block made of two parts for the treatment of hair, the first of said parts comprising pliers, an inner electrical resistance carried by said pliers, said pliers being heated when an electrical current passes through said re-

sistance, contacts, and means operatively connecting said contacts with said electrical resistance, the second of said parts comprising a junction box comprising supports which carry
 5 said pliers, resilient spangles connected with said supports and in contact with said contacts to transmit an electrical current to said resistance, and means for supplying an electrical
 10 current to said spangles, said junction box being adapted to receive the first of said part and closely surround the same, whereby the loss of heat is substantially reduced.

3. A device for the treatment of hair which comprises a heat accumulator and a separate
 15 junction box, said heat accumulator comprising pliers, an inner electrical resistance and conducting means connected with said resistance; said junction box comprising an insulating socket having the form of a hollow container, a sup-
 20 port situated within said socket for carrying said pliers, and conducting means carried by said socket and contacting the first-mentioned conducting means, the second-mentioned conduct-
 25 ing means receiving an electrical current and transmitting it to the first-mentioned conducting means and said resistance, said junction box receiving said heat accumulator and closely surrounding the same, whereby the loss of heat

generated by said resistance is substantially reduced.

4. A device for the treatment of hair which comprises a heat accumulator and a separate
 5 junction box, said heat accumulator comprising pliers, an inner electrical resistance, a pair of contacts and means operatively connecting said
 10 contacts with said resistance; said junction box comprising an insulating socket having the form of a hollow container and provided with a bot-
 15 tom and side walls having openings formed therein, a pair of supports situated within said socket and constituting a part of the side walls
 20 thereof, a pair of resilient conducting spangles attached to said side walls and extending through said openings, said supports being
 25 adapted to carry said pliers, said spangles being adapted to contact said contacts to transmit an electrical current to said resistance, and a pair
 of terminals carried by the bottom of said socket and operatively connected with said spangles, said terminals receiving an electrical current and
 transmitting it to said spangles, said junction box receiving said heat accumulator and closely surrounding the same, whereby the loss of heat
 generated by said resistance is substantially reduced.

JULIEN WARET.