

19



ORGANISATION AFRICAINE DE LA PROPRIETE INTELLECTUELLE

51

Inter. Cl.⁸ G01N 21/84 (06.01)

11

N° 17626

FASCICULE DE BREVET D'INVENTION

21 Numéro de dépôt : 1201400344
(PCT/SG13/000042)

22 Date de dépôt : 01/02/2013

30 Priorité(s) :

SG n° 201200771-2 du 02/02/2012
EP n° 12305958.6 du 02/08/2012

24 Délivré le : 31/08/2016

45 Publié le : 15.05.2017

73 Titulaire(s) :

BECTON DICKINSON HOLDINGS PTE.LTD.,
30 Tuas Avenue 2,
SINGAPORE 639461 (SM)

72 Inventeur(s) :

CARREL, Franck (FR)
PEROT, Frédéric (FR)

74 Mandataire : SCP ATANGA IP, 2nd Floor,
Immeuble Tayou Fokou, Douche-Akwa, B.P. 4663,
DOUALA (CM).

54 Titre : Adaptor for coupling with a medical container

57 Abrégé :

The present invention relates to an adaptor (10) for coupling with a vial (1) having a collar (3) closed by a septum (4), said septum having an outer surface directed towards the outside of the vial, the adaptor comprising : - a gripping member (20) for securing the adaptor to the vial, said gripping member being capable of being laterally mounted on the collar of said vial and - a pierceable elastomeric piece (30) having at least a part intended to be in contact with the outer surface of the septum when said adaptor is secured on said vial. The invention also relates to an assembly comprising such an adaptor and a vial.

Fig. 10A

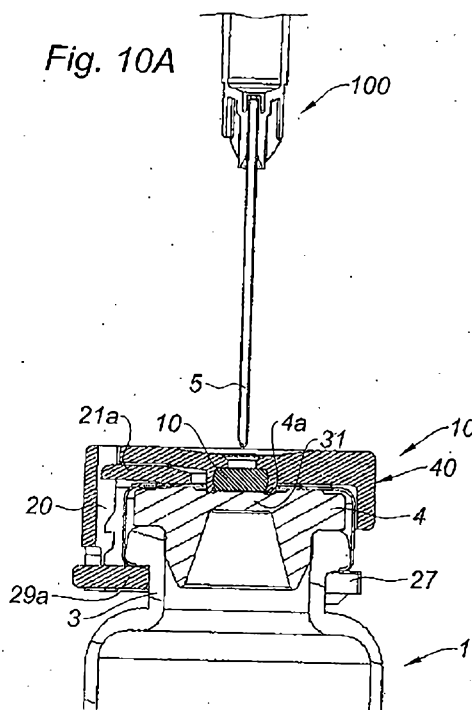

ADAPTOR FOR COUPLING WITH A MEDICAL CONTAINER

The present invention relates to an adaptor for coupling to a medical container such as a vial containing a pharmaceutical product, such as
5 a vaccine, said adaptor allowing for multiple aseptic needle piercing with an injection device to be filled with part of the product contained in the medical container.

In this application, the distal end of a component or apparatus must be understood as meaning the end furthest from the hand of the user and the
10 proximal end must be understood as meaning the end closest to the hand of the user, with reference to the injection device intended to be used with said component or apparatus. As such, in this application, the distal direction must be understood as the direction of injection with reference to the injection device, and the proximal direction is the opposite direction, i.e. the direction of
15 the transfer of the product from the vial to the injection device.

One of the ways to improve health is to immunize entire populations against a number of diseases. To date, injection administration is the most common method of administering vaccines.

Each year, numerous drugs, for example vaccines, need to be
20 prepared throughout the world by healthcare institutions. Many vaccine compositions are usually not stable at room temperature and they must be stored at rather specific cold temperatures. Indeed, due to their biological nature, vaccines are complex to handle and to store. Vaccines are usually temperature sensitive and typically need to be maintained and stored at all time
25 between 2 and 8 degrees Celsius ($^{\circ}\text{C}$). Some vaccines will be more sensitive to heat exposure and others will be sensitive to freezing. Therefore, maintaining and monitoring the appropriate temperatures during the storage and the handling of vaccines is a critical issue in order to sustain their efficacy. Overexposure to heat as well as overcooling may result in the destruction of
30 the biological elements of the vaccines. Use of vaccines not stored in appropriate conditions may lead to not effective vaccination of the populations against diseases and would lead to expensive campaigns with limited results.

Furthermore, it is critical that the cold chain be not interrupted from
35 production of the drug at a pharmaceutical company to its administration to the patient.

From a supply chain perspective, the most efficient vaccine packaging is the multidose container such as multidose vial, that is to say, vial that may contain up to 10, 100 or 1000 doses of vaccine, one dose being intended for one patient. These vials are usually closed by a septum. In
5 preparation of an injection of a vaccine, the user pierces the septum of the vial with the needle of an empty syringe, he then fills the syringe with one dose of vaccine and proceeds to the injection of the vaccine to the patient.

As such, multidose vials imply that the septum of the vial be pierced successively a high number of times, namely as many as the number of doses
10 present in the vial. In order to ensure safe injections, the sterility of the septum of the vial should be maintained during the whole time the vial is used.

Anyway, in locations where it is difficult to maintain favorable hygienic conditions such as remote locations which are far from towns and from hospital facilities, the multidose vials may be handled and manipulated at
15 ambient air. In such cases, the septum of the vial may be contaminated either by the ambient air, or, each time a dose of vaccine is removed, by the needle of the empty syringe used.

In addition, in regions where there is limited or potentially no supply of energy to power cooling equipment such as a refrigerator, the multidose vials
20 may be maintained in cold conditions by simple contact with ice packs. As time goes by, part of the ice may melt and turn into water, and the septum of the multidose vials may be in contact with such water that may contaminate the septum of the vial.

It may then happen that a multidose vial, such as for example a 10-
25 dose vial, is opened and that only three doses are used, for vaccinating three patients only, the remaining content of the vial being wasted because not intended to be administered in a sufficiently short time after opening of the vial in order to guaranty the vaccine or drug sterility.

Vaccination campaigns can therefore be made difficult in some
30 regions and a significant proportion of vaccines may be wasted by the time they reach their target. This has an unacceptable cost to the health organizations in charge of immunization campaigns. In addition, it may happen that in case of vaccination campaigns, or pandemic, hundreds of patients need to be vaccinated in a very short time, in locations where it is difficult to maintain

favorable hygienic conditions such as remote locations which are far from towns and from hospital facilities.

Therefore, it would be desirable to provide a device that would allow several successive piercings of a multidose vial septum and that would
5 guarranty that said piercings be carried out in aseptic conditions, in particular that the septum be made sterile at the time of injection act, or be maintained sterile during the lifetime of the multidose vial, and that would prevent wastage of the drug, even if the multidose vial is not stored or manipulated in aseptic conditions.

10 A first aspect of the present invention is an adaptor for coupling with a medical container having a collar closed by a septum, said septum having an outer surface directed towards the outside of the medical container, the adaptor comprising:

- a gripping member for securing the adaptor to the medical
15 container, said gripping member being capable of being laterally mounted on the collar of said medical container,

- a pierceable elastomeric piece having at least a part intended to be in contact with the outer surface of the septum when said adaptor is secured on said medical container.

20 The adaptor of the invention is intended to be mounted on a medical container, such as for example a conventional vial for storing pharmaceutical products, such as multidose vials for vaccines. Such a vial 1 is shown on Figures 1A-1C and generally comprises a tubular barrel 2 having a longitudinal axis A, closed at an end and having a collar 3 at the opposite end,
25 said collar 3 being closed by a septum 4. Usually, the septum 4 is fixedly attached to the collar 3 of the vial 1 by a peripheral band 5, said peripheral band 5 leaving a part of the septum 4, herein called outer surface 4a of the septum, directly facing the outside of the vial 1, namely the outside environment. The septum 4 is usually made of a material impermeable to gas
30 and liquid and it seals hermetically the content of the vial 1. The septum 4 is also pierceable by the needle of an injection device intended to be filled with the product contained in the vial, said septum 4 being accessible to said needle via its outer surface 4a.

In the present application, "pierceable" means that the septum and
35 the elastomeric piece of the adaptor may be pierced and traversed by the

needle of an injection device such as a syringe, an auto-injector, or a reconstitution device, for example for administering a pharmaceutical product such as a drug or a vaccine.

The gripping member of the adaptor of the invention may be any
5 member capable of securing the adaptor around on the medical container, and in particular around the collar of the medical container, either in a temporary or permanent way.

The pierceable elastomeric piece of the adaptor of the invention has at least a part intended to be in contact with the outer surface of the
10 septum when said adaptor is secured on said medical container: in other words, the elastomeric piece has a design, shape, and location on the adaptor, allowing a part of it to be in contact, in particular in close contact, with the outer surface of the septum when said adaptor is secured on said medical container.

The adaptor of the invention allows piercing the septum of the
15 medical container in favorable hygienic conditions multiple successive times. Indeed, when the user decides to fill in an empty syringe with a dose of drug contained in the medical container, he simply secures the adaptor of the invention on the medical container by means of the gripping member. Once the adaptor is secured on the medical container, the pierceable elastomeric piece
20 of the adaptor is in contact, for example in tight contact, with the outer surface of the septum of the medical container. As a consequence, introducing the needle in the medical container implies that the needle pierces and traverses the elastomeric piece of the adaptor in the first place. During this step, the needle mechanically rubs against the material forming the elastomeric piece
25 and it is naturally cleaned, as the potential bacteria are wiped out from the needle when said needle penetrates the elastomeric piece. In addition, once the needle protrudes out of the elastomeric piece of the adaptor, it directly enters the septum of the medical container and may therefore not be contaminated by foreign elements. Indeed, since at least a part of the
30 pierceable elastomeric piece is in contact with the outer face of the septum when the adaptor is secured on the medical container, the needle is not in contact with ambient air when it successively penetrates the pierceable elastomeric piece and then the septum.

The user may repeat the piercing step with the needle of a new empty injection device until all the doses contained in the medical container are removed. The adaptor of the invention acts as a protection of the septum.

In embodiments, the elastomeric piece is made of a gas and liquid impermeable material capable of flexing under pressure. For example, the elastomeric piece has a thickness ranging from 1 to 8 mm, preferably from 2 to 4 mm. The elastomeric piece may show a hardness ranging from 10 to 100 Shore A, preferably from 40 to 70 Shore A, measured according to standard DIN 53505.

Suitable materials for the pierceable elastomeric piece of the adaptor of the invention include natural rubber, acrylate-butadiene rubber, cis-polybutadiene, chloro or bromobutyl rubber, chlorinated polyethylene elastomers, polyalkylene oxide polymers, ethylene vinyl acetate, fluorosilicone rubbers, hexafluoropropylene-vinylidene fluoride-tetrafluoroethylene terpolymers, butyl rubbers, polyisobutene, synthetic polyisoprene rubber, silicone rubbers, styrene-butadiene rubbers, tetrafluoroethylene propylene copolymers, thermoplastic-copolyesters, thermo-plastic elastomers, or the like or a combination thereof.

In embodiments, the pierceable elastomeric piece is self-resealing. "Self-resealing" means in the present application that the elastomeric piece closes automatically and rapidly the hole produced by the piercing of the needle, for example in less than 0.5 seconds, once the needle is removed from the elastomeric piece. This automatic closure step may occur a high number of times, for example as many times as necessary for removing the numerous doses of products contained in the multidose medical container. This automatic obstruction restricts or prevents air and/or contaminants from entering inside the medical container, as well as at the interface between the elastomeric piece and the septum, and thus allows asepsis maintenance. Moreover, the presence of the pierceable elastomeric piece of the adaptor of the invention gives time to the septum of the medical container to reseal, as the needle is still present in the pierceable elastomeric piece after it is removed from the septum. As such, neither air nor contaminants may be introduced in the medical container or at the interface between the elastomeric piece and the septum, even if the medical container is maintained under negative pressure after the withdrawing

of one or more doses of product. In addition, the septum of the medical container may itself be self-resealing.

Suitable materials for self-resealing pierceable elastomeric piece of the adaptor of the invention include synthetic polyisoprene, natural rubber, 5 silicone rubber, thermo-plastic elastomers, or the like or a combination thereof.

In embodiments, the pierceable elastomeric piece may further comprise a material including antiseptic agents, such as silver ions or copper ions. For example, silver salts or copper salts may be covalently linked to a polymer matrix of the pierceable elastomeric piece. Alternatively, silver salts or 10 copper salts may be included as a load during the manufacturing of the polymer present in the material comprised in the pierceable elastomeric piece. For example, the polymer matrix may be selected from silicone rubber, butyl rubber and/or halogenobutyl rubber. In embodiments, the pierceable elastomeric piece may be made in silicone rubber including silver ions : such 15 products are commercially available from the company Momentive Performance Materials under the tradenames "Statsil®" or "Addisil®". In embodiments, the pierceable elastomeric piece may consist in a silicone rubber including silver ions.

Pierceable elastomeric pieces of the adaptor of the invention, 20 comprising a material including antiseptic agents, such as silver ions or copper ions, show antiseptic properties. The growth of bacteria at the surface of the pierceable elastomeric piece is therefore directly prevented. These materials also show hydrophobic properties which prevent condensation formation, thereby further reducing growth of bacteria. As a consequence, when a needle 25 pierces a pierceable elastomeric piece of the adaptor of the invention comprising a material including antiseptic agents, before entering a vial for withdrawing a dose of product from said vial, the risk of contamination of the vial content is highly reduced.

Alternatively or in combination, the pierceable elastomeric piece 30 may comprise a coating comprising an antiseptic agent, such as chlorhexidine di-acetate. For example, the pierceable elastomeric piece may comprise a butyl rubber or a halogenobutyl rubber coated with a coating comprising chlorhexidine di-acetate. For example, a solution of chlorhexidine di-acetate may be applied on the pierceable elastomeric piece before being submitted to 35 UV cross-linking. Such kind of coatings are very interesting as they have fast

kinetic (within minutes) and therefore can clean a needle during its insertion within the pierceable elastomeric piece.

In embodiments, the surface of said part of the pierceable elastomeric piece is complementary to the whole outer surface of the septum. As such, whatever the piercing location of the pierceable elastomeric piece of the adaptor by the needle, the user is ensured that the distal tip of the needle will directly pierce the septum after being passed through the pierceable elastomeric piece. Therefore, said distal tip is not in contact with ambient air or with other elements that would be trapped between the outer surface of the septum and the surface of the pierceable elastomeric piece. In particular, in such embodiments, the outer surface of the septum and the complementary surface of the pierceable elastomeric piece match each other in such a way that they are in intimate contact together on their entire surface and lead to a closed interface.

In embodiments, the adaptor further comprises a compressive member for pressing said pierceable elastomeric piece onto said outer surface of the septum, when said adaptor is secured on said medical container, said compressive member being capable to transition from an inactive state, in which it does not exert pressure on said pierceable elastomeric piece, to an active state, in which it exerts pressure. For example, an initial distal pressure on the compressive member may be exerted by the user at the time he mounts the adaptor on the medical container, in particular in order to make the compressive member transition from its inactive state to its active state. Once in its active state, the compressive member exerts a pressure on the pierceable elastomeric piece, even after the user has released his initial distal pressure on the compressive member. Such embodiments ensure that the outer surface of the septum and the complementary surface of the pierceable elastomeric piece are in tight contact together and that no ambient air is trapped between the outer surface of the septum and the complementary surface of the pierceable elastomeric piece. The distal tip of the needle may not enter in contact with other elements than the pierceable elastomeric piece and the septum when it successively traverses the pierceable elastomeric piece and the septum. Furthermore, the interface between the septum and the pierceable elastomeric piece is now sealed :no ambient air can be sucked into the medical container

when the needle is removed from the pierceable elastomeric piece and the medical container septum.

In embodiments, the adaptor further comprises a fixing system for preventing releasing of said gripping member and definitively securing the adaptor on said medical container. Such embodiments ensure that the adaptor is not separated from the medical container and prevent any re-use of the adaptor on another medical container. The favorable hygienic conditions of the medical container are therefore maintained.

In embodiments, the adaptor further comprises a transversal wall connected to said gripping member, said transversal wall having a hole in which is lodged said pierceable elastomeric piece. For example, the gripping member and the transversal wall may be formed of one single piece. In embodiments, the transversal wall is proximally deflectable. For example, the transversal wall may be proximally deflected by the collar of the medical container when the adaptor is mounted on the medical container, the transversal wall coming back to a non deflected position once the adaptor is correctly fitted on the collar of the medical container. In particular, the proximally deflectable transversal wall may be made of a flexible or semi-rigid material so that the transversal wall comes back automatically to its non deflected position once the adaptor is correctly fitted on the collar of the medical container. In such a case, the proximally deflectable transversal wall also acts as the compressive member and is capable to transition from an inactive state, namely in its deflected position, in which it does not exert pressure on said pierceable elastomeric piece, to an active state, where it is back to its non-deflected position, in which it exerts pressure on said pierceable elastomeric piece.

In embodiments, the gripping member is provided with a plurality of first recesses with sloped distal faces and of second recesses, and the compressive member is provided with inner radial pegs, said inner radial pegs being engageable with said first recesses and/or second recesses.

For example, the gripping member may be a lateral clipping member comprising a U-shaped element intended to be engaged on said collar via the open part of the U-shaped element, the curved part of the U-shaped element partially surrounding the collar. For example, the transversal wall may join together the two branches of the U of the U-shaped element.

In other embodiments, the gripping member is an axial clipping member capable of being axially mounted on the collar of said medical container. For example, the axial clipping member may comprise a tubular element capable of being axially engaged on said collar. For example, the transversal wall may then be a disk wall contained within the tubular element.

In embodiments, the lateral clipping member is adapted to receive large diameter vials, with a collar having typically a diameter of 20 mm, and is therefore not compatible with small diameter vials having typically a collar with a diameter of 13 mm. Therefore, a vial collar ring may be provided to be used with small diameter vials in order to fit with the adaptor of the present invention. For example, such vial collar ring is provided with two cylindrical portions: a top portion with a large diameter to enclose the vial septum and the peripheral band, and a bottom portion with a small diameter to enclose the vial collar. This vial collar ring may consist in two hemi-rings connected together for example by a hinge that can be plugged to each other on their free extremity by a snap-in lock. The snap-in lock may comprise a snap-in portion on the first ring and a recess on the second ring. With this snap-in lock, the vial collar ring can either be provided in an open state or in a closed state. The vial collar ring can be plugged onto a small diameter vial. Then, the adaptor of the present invention can be mounted on the small diameter vial having such vial collar ring.

In embodiments, the adaptor further comprises a cleaning pad, said cleaning pad being configured to at least partially slide on said outer surface of said septum when the adaptor is being mounted on the medical container. Such embodiments allow the outer surface of the septum, where the distal tip of the needle is intended to penetrate, to be automatically cleaned before the adaptor is secured to the medical container.

The cleaning pad may be any pad, such as fabric or sponge, for example out of cotton or any other porous material, and may be treated by a cleaning solution. For example, the cleaning pad may comprise a disinfecting agent. The outer surface of the septum is therefore disinfected before the elastomeric piece of the adaptor comes in contact with it. The disinfecting agents may be selected from alcohols, such as ethanol or isopropanol, organic solvents, such as nitrofurane, toluene, phenol and derivatives thereof, derivatives of quinoline and acridine, salts such as sodium hypochlorite, sodium chlorite or sodium chlorate, chlorine dioxide, salts of iodine, mercury, silver,

ammonium, or the like, or a combination thereof. For example, the disinfecting agent may be selected according to the most common bacteria and viruses that may be found in the area of use of the medical container.

In particular, the cleaning pad may be provided as a part of the adaptor, for example as a part of the transversal wall. The user has no additional operation or action to do than simply mounting the adaptor on the vial. Because of the location and configuration of the cleaning pad on the adaptor, the cleaning pad automatically slides on the outer surface of the septum, thereby wiping out potential bacteria or contamination agents present on said outer surface, when the user completes the step of mounting the adaptor on the collar of the vial.

For example, in embodiments where the lateral clipping member comprises a U-shaped element intended to be engaged on said collar via the open part of the U, the curved part of the U partially surrounding the collar, said transversal wall may be provided in the direction of the free ends of the U-shaped element, with a projection provided with said cleaning pad. For example, the cleaning pad is located on the distal face of the projection. As such, when the user approaches the free ends of the U of the lateral clipping member towards the collar of the vial, the cleaning pad enters in contact with an edge of the outer surface of the septum. While the user continues to move the lateral clipping member towards the collar so as to mount it thereon, the cleaning pad slides on the outer surface of the septum, until it loses contact with said septum when the lateral clipping member reaches its position where it is secured on the collar. In this position, because of its location at the free ends of the U, the cleaning pad does not face the septum anymore and it does not prevent the piercing of the septum by the needle to take place. During the mounting step of the adaptor on the collar as described above, the sliding of the cleaning pad onto the outer surface of the septum has wiped out the bacteria and/or contamination elements potentially present on said outer surface. The outer surface of the septum is therefore decontaminated when the elastomeric piece of the adaptor comes in contact with it.

In embodiments where the axial clipping member comprises a tubular element capable of being axially engaged on said collar, said transversal wall being located within said tubular element, the cleaning pad may be a breakable membrane attached to the inner wall of said tubular

element, and located distally with respect to said transversal wall. As such, when the user approaches the distal free end of the tubular element of the axial clipping member towards the collar of the vial, the breakable membrane enters in contact with the outer surface of the septum. While the user continues to move the axial clipping member distally so as to mount it on the collar of the vial, the breakable membrane, which is attached to the inner wall of the tubular element, becomes stretched out on the outer surface of the septum and finally breaks on said outer surface and is torn in several parts that slide on said outer surface while the axial clipping member reaches its position where it is secured on the collar. In this position, because it is now torn in several parts hanging along the inner walls of the tubular element, the membrane does not face the septum anymore and it does not prevent the piercing of the septum by the needle to take place. During the mounting step of the adaptor on the collar as described above, the sliding of the several torn parts of the breakable membrane on the outer surface of the septum has wiped out the bacteria and/or contamination elements potentially present on said outer surface. The outer surface of the septum is therefore decontaminated when the elastomeric piece of the adaptor comes in contact with it.

In embodiments, the cleaning pad is located on a removable part of said adaptor. For example, said removable part may be removed from said adaptor once said adaptor is secured on said medical container. Such embodiments allow extensive cleaning by healthcare workers of the medical container septum and/or of other surfaces such as the injector needle or the patient's skin, as well as prompt disposal of the cleaning pad after use, or may allow avoiding contamination with a harmful disinfecting agent.

In embodiments, a tubular lodging extends from said transversal wall in the proximal direction, said tubular lodging being shaped and dimensioned for receiving an injection device. For example, the tubular lodging may be capable of receiving an empty injection device to be filled with a dose of the drug contained in the medical container. In embodiments, a cavity filled with decontaminated atmosphere is provided in the tubular lodging, the needle of the injection device or syringe received in said tubular lodging being lodged in said cavity. Such embodiments allow better hygienic conditions for proceeding to the piercing of the outer surface of the septum of the medical container.

In embodiments, the removable part on which the cleaning pad is located is a portion of a blister surrounding said adaptor in a storage state. For example, said portion of said blister may remain on the adaptor while the adaptor is mounted on the collar and may be removed thereafter, once the
5 cleaning pad has completed its function of decontaminating the outer surface of the septum. In embodiments, the blister is provided with front guiding projection.

In embodiments, the adaptor further comprises an air inlet for allowing air entrance into the medical container, once the adaptor is secured on
10 said medical container. Such embodiments are advantageous in the case the medical container is made of glass or polymeric materials the walls of which are not collapsible. The presence of an air inlet prevents the formation of vacuum in the medical container when the medical fluid is withdrawn therefrom. For example, the air inlet comprises a cannula extending from the adaptor in
15 the distal direction and provided with a sharp distal tip, capable of piercing the septum of the medical container, the proximal end of the cannula protruding outside the adaptor in ambient atmosphere. In embodiments, the air inlet is provided with a filter to restrict, in embodiments to prevent, entry of particulates or bacteria from the ambient atmosphere into the medical container, in
20 particular during the vaccine withdrawal process. For example, this filter has a pore size of approximately 0.22 microns. This filter may also be provided with silver antimicrobial additive in order to obtain a supplementary protection of the vial sterility. Alternatively or in addition, this filter may be provided with a chlorhexidine coating. Such a filter is commercially available from Porex®
25 under the tradename Barrier Technology™.

In embodiments, the adaptor further comprises a pierceable decontamination insert located proximally with respect to said elastomeric piece. In such embodiments, the distal tip of the needle therefore first pierces the decontamination insert, in which it is decontaminated, then the pierceable
30 elastomeric piece, in which it is submitted to a mechanical cleaning as explained above, before entering in contact with the outer surface of the septum of the vial. For example, the pierceable decontamination insert may be a sterilizing gel.

In embodiments, the adaptor further comprises a counting system.
35 Such embodiments allow the user to be provided with information about how

many doses of product have already been withdrawn from the medical container or how many doses of product remain in the medical container. For example, the counting system may be manually actionable.

In embodiments, the adaptor is further provided with a time monitoring system. A time monitoring system allows monitoring the elapsing time from the first dose withdrawal. A time monitoring system may also indicate to the user what is the time remaining before a determined deadline, such for example a 28 or 30 days deadline.

In embodiments where a blister surrounds said adaptor in a storage state, the time monitoring system is capable of being triggered once the adaptor is mounted on the collar of the drug container, by a peg of the blister coming in contact with the time monitoring system when a user applies a distal pressure on a shell of the blister.

Another aspect of the invention is an assembly comprising a medical container having a collar closed by a septum, said septum having an outer surface directed towards the outside of the medical container, and an adaptor as described above. In embodiments, the septum is self-resealing.

The present invention will now be described in greater detail based on the following description and the appended drawings in which :

Figures 1A-1C are respectively a perspective view, a partial side view and a partial cross section view of a conventional vial on which the adaptor of the invention is to be mounted,

Figures 2A-2B are perspective views of an adaptor in accordance with an embodiment of the invention, respectively from the top front and from the bottom front, in a position for being mounted on the collar of a vial : Figure 2C is a cross section view of the adaptor of Figures 2A-2B,

Figures 3A-3C are perspective views of the gripping member of the adaptor of Figures 2A-2C, respectively from the top front, from the bottom front and from the rear; Figure 3D is a cross section view of the gripping member of Figure 3C along line I-I',

Figures 4A and 4B are perspective views of the compressive member of the adaptor of Figures 2A-2C, respectively from the bottom front and from the top front,

Figure 5 is a perspective view of the elastomeric piece of the adaptor of Figures 2A-2C,

Figures 6A-6B are perspective views of the adaptor of Figures 2A-2C, respectively from the top front and from the bottom front, in a position where it is definitely secured on the collar of a vial (not shown); Figure 6C is a cross section view of the adaptor of Figures 6A-6B,

5 Figure 7 is a cross section view of the adaptor of Figure 2C packed in a closed blister in a storage position,

Figure 8 is a cross section view of the adaptor of figure 7 with the blister open, and of the proximal region of the vial onto which the adaptor is to be secured,

10 Figure 9A and 9B are cross section views of the adaptor of Figure 8 once it is mounted on the collar of the vial, and once it is definitively secured on the collar of the vial, with the blister partially surrounding the adaptor,

Figure 10A is a partial cross section view of a needle of an injection device ready to pierce the elastomeric piece of the adaptor and assembly of Figure 9B, once the blister has been fully removed, in order to remove a dose of product from the vial,

15 Figure 10B is a side view of the injection device and assembly of Figure 10A at a larger scale,

20 Figures 11A and 11b are schematic cross section views of another embodiment of the adaptor and assembly of the invention, in which the clipping member is axial and the cleaning pad is a breakable membrane,

Figures 12A and 12b are respectively a perspective view and a partial perspective section view of another embodiment of an assembly of the invention,

25 Figure 13 is a cross section view of another embodiment of the adaptor and assembly of the invention, comprising a pierceable decontamination insert,

Figure 14 is a cross view of another embodiment of the adaptor and assembly of the invention, comprising an air inlet,

30 Figure 15 is a side view of another embodiment of the adaptor and assembly of the invention, comprising a tubular lodging shaped and dimensioned for receiving an injection device,

Figure 16 is an exploded view of another embodiment of the adaptor of the invention, comprising a dose counter,

Figure 17 is a top perspective view of the dose counter of the adaptor of Figure 16,

Figures 18A and 18B are respectively a top perspective view and a bottom perspective view of the adaptor of Figure 16,

5 Figures 19A and 19B are respectively a top perspective view of an opened vial collar ring and a bottom perspective view of a closed vial collar ring,

Figure 20 is a cross view of a closed vial collar ring mounted onto a vial,

10 Figure 21 is a cross section view of an adaptor of the invention provided with a monitoring system and partially surrounded by a blister, before triggering of the monitoring system,

Figure 22 is a cross section view of the adaptor of Figure 21, once the adaptor is mounted on the collar of a vial and the monitoring system has
15 been triggered.

With reference to Figures 2A-2C is shown an adaptor 10 in accordance with an embodiment of the invention, in a position for being mounted on a multidose vial 1 as shown on Figures 1A-1C. The adaptor 10 comprises a gripping member 20 intended to secure it onto the vial 1, and an
20 elastomeric piece 30 which is pierceable by the needle of an injection device. The adaptor 10 also comprises a compressive member 40, for pressing the elastomeric piece 30 onto the outer surface 4a of the septum 4, when the adaptor 10 is secured on the vial 1. As will be shown from the description below, the compressive member 40 is capable to transition from an inactive
25 state, in which it does not exert any pressure on the elastomeric piece 30, to an active state, in which it exerts such a pressure. In the embodiment shown, parts of the gripping member 20 and of the compressive member 40 are also useful in combination for forming a fixing system for preventing the release of the gripping member 20 and definitively securing the adaptor 10 on the vial 10, as
30 will be explained below.

With reference to Figures 3A-3D, the gripping member 20 will now be described in detail. The gripping member 20 is a lateral gripping member and comprises a U-shaped body 21, having a partially tubular wall 22 showing a height suitable for surrounding the collar 3 of the vial 1 (see figures 9A-B),
35 with two free ends 22a corresponding to the ends of the branches of the U, the

U-shaped body 21 therefore forming a clipping member. Close to each free end 22a, the tubular wall 22 is provided on its outer surface with a first recess 23, and with a second recess 24, distally spaced with respect to the first recess 23. First recesses 23 are provided with sloped distal faces 23a. In its circular
5 portion, the partially tubular wall 22 is further provided on its outer surface with a pair of first rear recesses 25, and with a pair of second rear recesses 26, distally spaced with respect to the pair of first rear recesses 25. First rear recesses 25 are provided with sloped distal faces 25a. Still in its circular portion, the partially tubular wall 22 is further provided on its outer surface with
10 a rear projection 29 located between the two second rear recesses 26, and on its inner surface with a forward projection 29a.

Each free end 22a is further provided with a distal front projection forming a radial rim 27.

The U-shaped body 21 is further provided at its proximal end with
15 an inner annular rim 21a, forming a central hole 28.

With reference to Figures 4A and 4B, the compressive member 40 will now be described in detail. The compressive member 40 comprises a cap 41, formed of a tubular wall 42 closed at its proximal end by a transversal wall 41a. The cap 41 is sized and shape for receiving therein the gripping member
20 20. The transversal wall 41a is provided with a central hole 43 for receiving the elastomeric piece 30 (see Figure 2B). The tubular wall 42 is provided with an opening 44 on a part of its circumference, herein called "front part" of the compressive member 40, said opening 44 being intended to face and receive the free ends 22a of the gripping member 20 when the gripping member 20 and
25 the compressive member 40 are assembled together to form the adaptor of Figures 2A-2D.

In its front part, on each side of the opening 44, the tubular wall 42 is provided with a flexible leg 45 having a distal free end having an inner radial peg 45a. In its rear part opposite its front part, the tubular wall 42 is provided
30 with two rear flexible legs 46 having a distal free end having an inner radial peg 46a (see Figure 4A).

On Figure 5 is shown the pierceable elastomeric piece 30. In the embodiment shown, the pierceable elastomeric piece 30 has globally the shape of a flat cylinder. As shown on figures 2A-D and 6A-D, the pierceable
35 elastomeric piece 30 is dimensioned and shaped so as to be received within

central hole 43 of the transversal wall 41a of the cap 41 with friction. As also shown from these Figures, the distal face of the pierceable elastomeric piece 30 has a plane surface 31 having a rounded shape. In embodiments not shown, the pierceable elastomeric piece may have any suitable shape
5 complementary to that of the central hole of the transversal wall, such as a cubic shape, etc.

The pierceable elastomeric piece 30 is made of a material impermeable to gas and liquid capable of flexing under pressure. For example, the elastomeric piece has a thickness ranging from 1 to 8 mm, preferably from
10 2 to 4 mm. The elastomeric piece may show a hardness ranging from 10 to 100 Shore A, preferably from 40 to 70 Shore A, measured according to DIN 53505.

Suitable materials for the pierceable elastomeric piece 30 of the adaptor of the invention include natural rubber, acrylate-butadiene rubber, cis-polybutadiene, chloro or bromobutyl rubber, chlorinated polyethylene
15 elastomers, polyalkylene oxide polymers, ethylene vinyl acetate, fluorosilicone rubbers, hexafluoropropylene-vinylidene fluoride-tetrafluoroethylene terpolymers, butyl rubbers, polyisobutene, synthetic polyisoprene rubber, silicone rubbers, styrene-butadiene rubbers, tetrafluoroethylene propylene copolymers, thermoplastic-copolyesters, thermo-plastic elastomers, or the like
20 or a combination thereof.

Preferably, the elastomeric piece is self-resealing and it automatically seals the hole produced by the piercing of the needle, automatically and rapidly, for example in less than 0.5 seconds, once the needle is removed from the elastomeric piece. This automatic closure step may
25 occur a high number of times, in particular as many times as necessary for removing the numerous doses of product initially present in the multidose vial 1. Suitable materials for self-resealing pierceable elastomeric piece of the adaptor of the invention include synthetic polyisoprene, natural rubber, silicone rubber, thermo-plastic elastomers, or the like or a combination thereof.

30 In embodiments, the pierceable elastomeric piece may further comprise a material including antiseptic agents, such as silver ions or copper ions. For example, silver salt or copper salt may be covalently linked to a polymer matrix present in the material comprised in the pierceable elastomeric piece. Alternatively, silver salts or copper salts may be introduced as a load
35 during the manufacturing of the polymer present in the material comprised in

the pierceable elastomeric piece. For example, the polymer matrix may be selected from silicone rubber, butyl rubber and/or halogenobutyl rubber. In embodiments, the pierceable elastomeric piece comprises a material comprising a silicone rubber including silver ions : such products are commercially available from the company Momentive Performance Materials under the tradenames "Statsil®" or "Addisil®". In embodiments, the pierceable elastomeric piece may consist in a material including silver ions, such as silicone rubber including silver ions. In other embodiments, the pierceable elastomeric piece may consist in a material including copper ions.

Pierceable elastomeric pieces of the adaptor of the invention, comprising a material including antiseptic agents, such as silver ions or copper ions, show antiseptic and hydrophobic properties. The growth of bacteria is therefore directly prevented at the surface of the pierceable elastomeric piece. Moisture formation is also prevented, thereby further reducing the growth of bacteria. As a consequence, when a needle pierces a pierceable elastomeric piece of the adaptor of the invention comprising a material including antiseptic agents, such as silver ions or copper ions, in view of entering a vial for removing a dose of product from said vial, the risk of contamination of the vial content is reduced.

Alternatively or in combination, the pierceable elastomeric piece may comprise a coating comprising an antiseptic agent, such as chlorhexidine di-acetate. For example, the pierceable elastomeric piece may comprise a butyl rubber or a halogenobutyl rubber coated with a coating comprising chlorhexidine di-acetate. Such a coating may be obtained by UV cross-linking. The antiseptic action of such a coating may occur within minutes and such a coating may therefore be able to clean a contaminated needle during its insertion within the pierceable elastomeric piece.

For example, a solution of chlorhexidine di-acetate may be applied on the pierceable elastomeric piece before being submitted to UV cross-linking. Such kind of coatings are very interesting as they have fast kinetic (within minutes) and therefore can clean a needle during its insertion within the pierceable elastomeric piece.

The use of the adaptor 10 in connection with a vial of figures 1A-1C will now be explained with reference to figures 2A-10B.

The adaptor 10 is provided to the user with the gripping member 20, the pierceable elastomeric piece 30 and the compressive member 40 assembled together in the inactive state of the compressive member 40 as shown on Figures 2A-2C, and packed in a blister 50 as shown on Figure 7.

5 With reference to Figures 2A-2C, the pierceable elastomeric piece 30 is lodged in the central hole 43 of the cap 41 in which it remains fixed by friction, with its plane and rounded distal face 31 protruding distally outside said central hole 43, and its proximal face 32 protruding proximally outside the central hole 43. The cap 41 is assembled on the U-shaped body 21 by means
10 of inner radial pegs 46a (Figure 4A) being engaged in first rear recesses 25, and of inner radial pegs 45a being engaged in first recesses 23. In this position, the opening 44 of the tubular wall 42 faces the free ends 22a of the tubular wall 22 of the U-shaped element 21, and the central hole 43 with the elastomeric piece 30 faces the central hole 28 of the gripping member 20.

15 With reference to Figure 7, the adaptor 10 is packed before use in a blister 50 surrounding the adaptor 10. The blister 50 comprises a shell 51 closed by a pellicle film 52. The shell 51 is provided with a front projection 51a carrying a cleaning pad 60, and with front guiding projections 53 located distally with respect to said front projection 51a.

20 The cleaning pad 60 may be any pad, such as fabric or sponge, for example out of cotton or any other porous material, and may be imbibed with a cleaning solution or disinfecting composition. For example, the cleaning pad 60 may comprise a disinfecting agent. The disinfecting agents may be selected
25 from alcohols, such as ethanol or isopropanol, organic solvents, such as nitrofurane, toluene, phenol and derivatives thereof, derivatives of quinoline and acridine, salts such as sodium hypochlorite, sodium chlorite or sodium chlorate, chlorine dioxide, salts of iodine, mercury, silver, ammonium, or the like, or a combination thereof.

30 Once the user is ready to proceed to the withdrawal of a dose of product contained in the vial 1, he removes the pellicle film 52 in order to open the blister 50. In the embodiment shown, the shell 51 remains on the adaptor 10 until the adaptor 10 is secured on the collar 3 of the vial 1. The shell 51 is removed thereafter, before piercing of the elastomeric piece 30 by the needle of the injection device. In other embodiments, the whole blister 50 may be
35 removed before mounting the adaptor 10 on the vial 1.

With reference to Figure 8, the user then approaches the front part of the adaptor 10 with the shell 51 towards the collar 3 of vial 1, in order to mount laterally the adaptor 10 onto the collar 3 of the vial 1. The front guiding projections 53 of the shell 51 slide around the collar 3 so as to guide the adaptor 10 and ensure appropriate positioning and correct fitting of the gripping member 20 on the collar 3 of the vial 1. The cleaning pad 60 enters first in contact with an edge of the outer surface 4a of the septum 4. While the user continues to move laterally the shell 51 containing the adaptor 10, and thus the lateral clipping member 20 towards the collar 3 so as to mount it thereon, the cleaning pad 60 slides on the outer surface 4a of the septum 4, until it loses contact with said septum 4 when the clipping member 20 reaches its position where it is secured on the collar 3, by means of forward projection 29a and radial rims 27 surrounding the collar 3, as shown on Figure 9A.

During the mounting step of the adaptor 10 on the collar 3 as described above, the sliding of the cleaning pad 60 onto the outer surface 4a of the septum 4 has wiped out bacteria and/or contamination elements potentially present on said outer surface 4a. The outer surface 4a of the septum 4 is therefore decontaminated when the elastomeric piece 30 of the adaptor 10 comes in contact with it.

Moreover, the lateral mounting of the clipping member 20 allows a compressive and precise positioning of the adaptor 10 onto the vial collar 3. The connection of the adaptor 10 on the vial 1 is straightforward for the user and can be performed easily, even with a single hand.

In another embodiment (not shown), where the blister 50 is fully removed before mounting the adaptor 10 on the vial 1, the cleaning pad 60 is provided on a proximal front projection of a free end 22a, for example opposite the radial rims 27.

In another embodiment (not shown), the adaptor 10 is provided in a blister 50 without a cleaning pad.

Back to Figure 9A, once the adaptor 10 is secured on the collar 3 of the vial 1 by means of the gripping member 20, the user applies a distal pressure on top of the shell 51 in order to make the compressive member 40 transition from its inactive state to its active state, as shown on Figure 9B. Under this distal pressure, the compressive member 40 has moved distally with respect to the gripping member 20 : the inner radial pegs 46a have been able

to escape the first rear recesses 25 by overcoming distal sloped faces 25a, and have become engaged in second rear recesses 26. In the same manner, inner radial pegs 45a have been able to escape first recesses 23 by overcoming distal sloped faces 23a, and have become engaged in second recesses 24, as shown on Figures 6A-6C and 9B.

As shown from Figure 9B, the pierceable elastomeric piece 30 is now compressed and flexes under the pressure exerted by the compressive member 40 on the gripping member 20. In addition, as is clear from Figure 9B, the distal face 31 of the elastomeric piece 30 has a surface which is complementary to that of the septum 4, and this surface is tightly and intimately in contact with the outer surface 4a of the septum 4 so that no foreign elements may be present between the distal face of the elastomeric piece 30 and the outer surface 4a now cleaned and disinfected.

In addition, by cooperation of the forward projection 29a and radial rims 27 coming in abutment on the collar 3 of the vial 1 and of the pegs (45a, 46a) of the compressive member 40 being engaged in the recesses (24, 26) of the gripping member 20, the adaptor is now secured on the collar in a permanent way and may not be removed.

In general, the adaptor 10 is thus secured on the collar 3 of the vial 1 in a two steps process. In the first step, the lateral gripping member 20 is mounted on the collar 3 by a lateral movement allowing an appropriate positioning, like for example the correct axial alignment of the elastomeric piece 30 of the adaptor 10 regarding the central hole 43 of the septum 4, but also a perfect transversal alignment of the distal face 31 of the elastomeric piece 30 and the outer surface 4a of the septum 4. The adaptor 10 is still in an inactive state as there is no contact between the elastomeric piece 30 and the septum 4. In the second step, the compressive member 40 is definitely secured on the collar 3 by a distal movement with respect to the gripping member 20. The adaptor is now in an active state with a close contact between the elastomeric piece 30 and the septum 4. Therefore, thanks to these two steps securing process, air-tightness between the elastomeric piece 30 and septum 4 is achieved avoiding any contamination.

Indeed, once the adaptor 10 is secured on the collar 3 of the vial 1, various contaminations of the inside vial 1 are avoided, and this ensures that the contents of the vial 1 will not be polluted.

The forward projection 29a, radial rims 27 and the recesses (24, 26) of the gripping member 20 form, in combination with the pegs (45a, 46a) of the compressive member 40, a fixing system for preventing the releasing of the gripping member 20 and definitively securing the adaptor 10 on the vial 1.

5 This fixing system allows the maintenance of a sufficient pressure between the distal face 31 of the elastomeric piece 30 and the outer face 4a of the septum 4 in order to ensure the air-tightness between these surfaces. Moreover, this fixing system is useful as it allows a very tight hermetic contact between the two pieces 30 and 4, even if the dimensions of the different parts
10 of the adaptor are not always accurate due to the manufacturing tolerances which can be significant on all small plastic or elastomeric parts.

Additionally, this fixing system allows the free rotation of the vial 1 regarding to the adaptor 10 in order to let the user move the vial while maintaining the adaptor, for example when he needs to find the information he
15 is looking for on a label present on the vial 1.

Then, when the adaptor is definitively secured on the vial, the user removes the shell 51 of the blister 50 and the adaptor 10 is ready to receive the needle 5 of an injection device 100, as shown on Figures 10A and 10B. It is therefore possible to pierce the elastomeric piece 30 of the adaptor 10 with the
20 needle 5 and then subsequently pierce the septum 4, as many times as necessary, as explained above, with desired hygienic conditions.

In the embodiment where the cleaning pad 60 is provided on the blister 50, the cleaning pad, once contaminated by the cleaning of the septum 4, is disposed with the blister and can not disturb the user in removing a dose
25 from the vial 1.

In the embodiment where the cleaning pad 60 is provided on a removable part of the adaptor 10 (not shown), the user may remove the pad once contaminated in order to prevent any disturbance during the dose withdrawal.

30 Figures 11A-15 show alternative embodiments of the adaptor 10 of Figures 1A-10B. References designating the same elements as in Figures 1A-10B have been maintained for Figures 11A-15.

With reference to figures 11A and 11B is shown schematically another embodiment of the adaptor 10 of the invention, in which the gripping
35 member 120 is an axial clipping member comprising a tubular element 122

capable of being axially mounted on the collar 3 of the vial 1, by means of flexible radial pegs 123 engageable on the collar 3. In the embodiment shown, the adaptor 10 is provided with a transversal wall 121 located within said tubular element 122, and the cleaning pad is a breakable membrane 160
5 attached to the inner wall of the tubular element 122, and located distally with respect to the transversal wall 121.

As such, when the user approaches the distal free end of the tubular element 122 of the gripping member 120 towards the collar 3 of the vial 1, as shown on figure 11A, the breakable membrane 160 enters in contact with
10 the outer surface 4a of the septum 4. While the user continues to move the gripping member 120 distally so as to mount it on the collar 3 of the vial 1, the breakable membrane 160, which is attached to the inner wall of the tubular element 122, becomes stretched out on the outer surface 4a of the septum 4 and finally breaks on said outer surface 4a and is torn in several parts that slide
15 on said outer surface 4a while the gripping member 120 reaches its position where it is secured on the collar 3. In this position, as shown on Figure 11B, because it is now torn in several parts (160a, 160b) hanging along the inner walls of the tubular element 122, the membrane 160 does not face the septum 4 anymore and it does not prevent the piercing of the septum 4 by the needle of
20 an injection device (not shown). During the mounting step of the adaptor 10 on the collar 3 as described above, the sliding of the several torn parts (160a, 160b) of the breakable membrane 160 on the outer surface 4a of the septum 4 has wiped out the bacteria and/or contamination elements potentially present on said outer surface 4a. The outer surface 4a of the septum 4 is therefore
25 decontaminated when the elastomeric piece 30 of the adaptor comes in contact with it, as shown on Figure 11B.

In embodiments not shown, the adaptor of Figures 11A and 11B is packed before use in a blister comprising a shell closed at its distal end by a transversal pellicle film. In embodiments, the breakable membrane may be part
30 of the blister and may be attached to the inner surface of the shell parallel to the distal transversal pellicle film.

With reference to Figures 12A and 12B is shown another embodiment of the adaptor 10 of the invention, in which the cleaning pad 260 is part of the gripping member 220. In this embodiment, the gripping member 220
35 is a lateral clipping member comprising a transversal wall 221 provided with a

hole 223 in which is lodged the elastomeric piece 30. The transversal wall 221 is proximally deflectable thanks to a rear hinge member 221a connecting the transversal wall 221 to the gripping member 220. The transversal wall 221 is provided with a front distal projection 224 bearing the cleaning pad 260. In this
5 embodiment, the adaptor 10 does not comprise any compressive member.

When the adaptor 10 of Figures 12A-12B is mounted laterally on the collar 3 of the vial 1, the transversal wall 221 is pushed in a proximal direction when it contacts the collar 3. The cleaning pad 260 is therefore caused to slide onto the outer surface 4a of the septum 4, thereby cleaning and
10 decontaminating said surface. The correct positioning of the adaptor 10 on the vial 1 is obtained when the collar 3 comes in abutment against the front distal projection 224 and the transversal wall 221 comes back to its non deflected position, as shown on figure 12B. In this position, the pierceable elastomeric piece 30 is in close contact with the septum 4 of the vial 1.

15 The gripping member 220 is therefore releasably secured on the collar 3 of the vial 1. The transversal wall 221 is deflectable after the adaptor is mounted, for release of the vial 1 if necessary.

With reference to Figure 13, is shown another embodiment of the adaptor 10 of the invention, in which a pierceable decontamination insert 70 is
20 located proximally with respect to the elastomeric piece 30. On the embodiment shown, the decontamination insert 70 comprises a sterilizing gel 71. For proceeding to the withdrawal of a dose of product from the vial 1, the needle 5 first traverse the sterilizing gel 71, in which it is sterilized, then the elastomeric piece 30, in which it is submitted to a mechanical cleaning, before it contacts
25 the septum 4. The piercing is therefore completed in improved hygienic conditions.

With reference to Figure 14, is shown another embodiment of the adaptor 10 of the invention, in which the adaptor 10 further comprises an air inlet 80 for allowing air entrance into the vial 1, once the adaptor 10 is secured
30 on the vial 1. On the example shown, the air inlet 80 comprises a cannula 81 extending from the adaptor 10 in the distal direction and provided with a sharp distal tip 82, capable of piercing the septum 4 of the vial 1, the proximal end 83 of the cannula 81 protruding outside the adaptor 10 in outside environment. The air inlet 80 is provided with a filter 84 to restrict or prevent entry of
35 contaminants such as particulates or bacteria from the ambient atmosphere

into the vial 1, in particular during the vaccine withdrawal process. For example, this filter 84 has a pore size of 0.22 microns like for example a filter with Porex™ technology. Such embodiments are advantageous in the case the vial is made of glass or polymeric materials the walls of which are not collapsible.

5 The presence of an air inlet prevents the formation of vacuum in the vial when medical fluid is withdrawn therefrom.

With reference to Figure 15 is shown another embodiment of the adaptor 10 of Figures 12A and 12B, in which a tubular lodging 90 extends from the transversal wall 221 in the proximal direction, the tubular lodging 90 being
10 shaped and dimensioned for receiving an injection device 100. For example, a cavity (not shown) filled with decontaminated atmosphere is provided in the tubular lodging 90, the needle of the injection device received in the tubular lodging 90 being lodged in said cavity. Such embodiments allow better hygienic and aseptic conditions for proceeding to the piercing of the outer surface 4a of
15 the septum 4 of the vial 1, as the needle of the injection device does not enter in contact with outside environment before piercing.

With reference to Figures 16-18B is shown another variant of the adaptor 10 of Figures 2A-6B further comprising a dose counter 91. The references designating the same elements as in Figures 2A-6B have been
20 maintained, augmented of 300.

With reference to Figures 16-18B, the compressive member 340 is formed of a cap 341 formed of a tubular wall 342 closed at its proximal end by a transversal wall 341a provided with a central hole 343. The tubular wall 342 is provided with an opening 344 on a part of its circumference and on its whole
25 height, herein called "front part" of the compressive member 340, the opening 344 comprising a transversal bridge 347 defining a proximal window 347a. The proximal face of the transversal wall 341a is provided with an opening 341b (see Figure 18A) radially spaced with respect to the center of the transversal wall 341a. The distal face of the transversal wall 341a is provided with a distally
30 extending collar 348 surrounding the central hole 343. In the distal region of the outer wall of the distally extending collar 348 are located two opposite outer ears 348a, only one of them being visible on Figure 16. The distal face of the transversal wall 341a is further provided with a plurality of circumferentially distributed recesses 349 located around the distally extending collar 348.

The dose counter 91 is made of a flat cylinder 92 provided with a plurality of circumferentially distributed peripheral projections 93 extending radially outwardly. The flat cylinder 92 is further provided with a central hole 94 dimensioned and shaped so as to fit around the distally extending collar 348 of the distal face of the transversal wall 341a of the compressive member 340, and so as to be snap-fitted thereon after overcoming the outer ears 348a of said distally extending collar 348. The flat cylinder 92 is snap-fitted on the collar 348 so that it is able to rotate with respect to said collar 348.

With reference to Figure 17, the proximal face of the flat cylinder 92 is further provided with two proximal pegs 95 located around the central hole 94. As will be shown later, these two proximal pegs 95 are intended to cooperate with the recesses 349 of the distal face of the transversal wall 341a of the cap 341 of the compressive member 340. The proximal face of the flat cylinder 92 is further provided with a plurality of circumferentially distributed information data 96, such as digits from "0" to "10" on the example shown.

When the adaptor 10 is assembled, as shown on Figures 18A and 18B, the flat cylinder 92 is snap-fitted onto the distally extending collar 348 of the distal face 341a of the cap 341 and it is therefore received within said cap 341 with a part of it protruding outside via the window 347a. The flat cylinder 92 is capable of rotating with respect to the collar 348, therefore with respect to transversal wall 341a. Anyway, before use, one of the information data, for example digit "0" faces the opening 341b of the transversal wall 341a and it is therefore visible by the user. In addition, in order to temporarily maintain the flat cylinder 92 in this position with respect to the transversal wall 341a, the proximal pegs 95 are each engaged in one of the plurality of circumferentially distributed recesses 349 located around the distally extending collar 348.

The user then uses the adaptor 10 in the same way as described for figures 1A-6B in order to withdraw a dose of product from a medical container. He then rotates the flat cylinder 92, for example manually by grasping one of the plurality of circumferentially distributed peripheral projections 93 extending radially outwardly, for example in the direction of the arrow 341c shown on Figure 18A. With this rotational movement, the proximal pegs 95 overcome the recesses 349 in which they were engaged, and become engaged in adjacent recesses 349, in which position the digit "1" now appears through opening 341b of the proximal face of the transversal wall 341a.

The flat cylinder 92 therefore forms a dose counter for counting how many doses of product have already been withdrawn or remain from the medical container.

In embodiments, the clipping member of the adaptor is adapted to receive large diameter vials, with a collar having typically a diameter of 20 mm, and is not compatible with small diameter vials having typically a collar with a diameter of 13 mm. Therefore, with reference to Figures 19A-20, a vial collar ring 400 may be provided to be used on small diameter vials in order to fit with the adaptor of the present invention. On Figures 19A, 19B and 20, a vial collar ring 400 is provided with two cylindrical portions: a top portion 401 with a large diameter capable of enclosing the vial septum 4 and the peripheral band 5 between the abutment 404 and 405, and a bottom portion 402 having a small diameter in order to enclose the vial collar 3. This vial collar ring 400 consists in two hemi-rings 410 and 411 connected together for example by a hinge 420 that can be plugged together on their free extremity by a snap-in lock 430. The snap-in lock comprises a recess 432 on the first hemi-ring 410 and a snap-in portion 431 on the second hemi-ring 411. Thanks to this snap-in lock 430 and the hinge 420, the vial collar ring 400 can either be provided in an open state (Figure 19A) or in a closed state (Figures 19B and 20).

The vial collar ring can be plugged onto a small diameter vial. Then, the adaptor of the present invention can be mounted on the small diameter vial equipped with the vial collar ring 400.

In embodiments, the adaptor of the present invention is provided with a time monitoring system. Indeed, such an adaptor is used to prevent contamination of the content of vial 1 for a limited period of time, for example up to 28 to 30 days. Therefore, a time monitoring system can be added to the adaptor in order to monitor the elapsing time from the first dose withdrawing or to indicate to the user what is the time remaining before the 28 or 30 days deadline.

This time monitoring system may be an electronic timer or a system based on the diffusion of ink into a circuit. For example, the elapsing or remaining time can be monitored by the kinetic of ink progression in a microfluidic circuit. Such systems are particularly attractive because they are small and reliable. For example some of them are commercially available under the trademark Timestrip®.

Furthermore, the time monitoring system may be triggered either manually by the user or automatically. An automatic trigger could occur when the adaptor is mounted on the collar 3 of the vial 1 which assumes a first dose withdrawing shortly afterwards. For example, such time monitoring label,
5 placed on an adaptor 10 could be triggered by an additional peg (not shown) placed into the blister 50 that comes in contact with the time monitoring system and therefore activates it when the user applies a distal pressure on the top of the shell 51.

Figures 21 and 22 show an alternative embodiment of the adaptor
10 10 of Figures 1A-10B, provided with a monitoring system, and surrounded by a blister 50 in a storage state of the adaptor. References designating the same elements as in Figures 1A-10B have been maintained for Figures 21-22.

With reference to Figures 21 and 22, the adaptor 10 is provided with a time monitoring system under the form of a support member 500
15 provided with a microfluidic circuit 501 connected to an ink reservoir 502 closed by a pellicle film 503, similar to the commercially available product sold under the tradename Timestrip® by the company Timestrip Ltd, UK. The shell 51 of the blister 50 is provided with a distal peg 54.

As seen on Figure 21, in a storage state of the adaptor 10, the
20 blister 50 surrounds the adaptor 10 and the distal peg 54 is adjacent to the pellicle film 503 of the ink reservoir 502 without interacting with said pellicle film 503.

The adaptor 10 is then mounted laterally onto the collar 3 of the vial in the same manner as that described with respect to Figures 7 to 9A above.
25 The presence of the blister 50 allows protecting the adaptor 10 from potentially contaminated hands or surfaces during this mounting step. Once the adaptor 10 and the blister 50 are secured on the collar 3 of the vial 1 by means of the gripping member 20, the user applies a distal pressure on top of the shell 51, as described in Figure 9B in order to make the compressive member 40
30 transition from its inactive state to its active state as shown on Figure 22.

Under this distal pressure, the distal peg 54 enters in contact with the pellicle film 503 of the ink reservoir 502 and causes it to burst. The time monitoring system is thereby triggered as the ink previously present in the ink reservoir 502 is now capable of diffusing into the microfluidic circuit 501. The
35 kinetic of ink progression in the microfluidic circuit 501 will from now on inform

the user of the elapsed time since the adaptor 10 was mounted onto the collar 3 of the vial 1, or alternatively of the remaining time before the drug contained in the vial 1 expires.

Such a system may prevent the injection of potentially expired
5 vaccines or drugs to patients, but may also facilitate the supply chain or stock management in drugstores or even avoid wastage of valuable drugs and vaccines by encouraging the use of the first opened vials.

The adaptor and assembly of the invention allow piercing the septum of a multidose vial yielding favorable hygienic and aseptic conditions
10 multiple successive times. Indeed, with the adaptor of the invention, introducing the needle of an injection device into the septum of a vial entails the needle piercing and traversing the elastomeric piece of the adaptor in the first place. During this step, the needle mechanically rubbing against the material forming the elastomeric piece and it is cleaned, as potential bacteria are wiped from the
15 needle when said needle penetrates the elastomeric piece. In addition, once the needle protrudes out of the elastomeric piece of the adaptor, it directly enters the septum of the vial and may therefore not be contaminated by foreign elements.

The user may repeat the piercing step with the needle of a new
20 empty syringe until all the doses contained in the vial are removed. The adaptor of the invention acts as a protection of the septum of the vial.

The pierceable elastomeric piece of the adaptor of the invention and the septum of the medical container are in contact, for example in tight contact, once the adaptor is secured onto the medical container. In
25 embodiments where both the pierceable elastomeric piece of the adaptor of the invention and the septum of the medical container are self-resealing, no possibility of communication exist between the inside of the medical container and the outside environment at the time the needle of the injection device is removed from both the septum and the pierceable elastomeric piece, after
30 withdrawal of a dose of product from the medical container. This therefore restricts or prevents the product contained in the medical container from being contaminated by outside contaminants such as bacteria, unpurified water, particles, viruses, etc...The adaptor of the invention thus allows a hermetic sealing of the contents of the medical container it is secured on, even during
35 the removal of the needle. The inside of the medical container is kept in aseptic

30

conditions before, during and after a withdrawal of a dose from the medical container.

CLAIMS

1. An adaptor (10) for coupling with a medical container (1) having a collar (3) closed by a septum (4), said septum having an outer surface (4a) directed towards the outside of the medical container, the adaptor comprising:

5 - a gripping member (20; 220) for securing the adaptor to the medical container, said gripping member being capable of being laterally mounted on the collar of said medical container,

 - a pierceable elastomeric piece (30) having at least a part (31) intended to be in contact with the outer surface of the septum when said
10 adaptor is secured on said medical container.

2. The adaptor of claim 1, wherein the surface of said part (31) of the pierceable elastomeric piece is complementary to the whole outer surface of the septum.

3. The adaptor (10) of claim 1 or 2, further comprising a
15 compressive member (40; 221) for pressing said pierceable elastomeric piece onto said outer surface of the septum, when said adaptor is secured on said medical container, said compressive member being capable to transition from an inactive state, in which it does not exert pressure on said pierceable elastomeric piece, to an active state, in which it exerts pressure.

20 4. The adaptor (10) of any one of claims 1 to 3, further comprising a fixing system (24, 26, 27, 29a, 45a, 46a) for preventing releasing of said gripping member and definitively securing the adaptor on said medical container.

5. The adaptor (10) of any one of claims 1 to 4, further comprising
25 a transversal wall (41a, 121, 221) connected to said gripping member, said transversal wall having a hole in which is lodged said pierceable elastomeric piece.

6. The adaptor (10) of claim 5, wherein said transversal wall (221) is proximally deflectable.

30 7. The adaptor (10) of any one of claims 3 to 6, wherein the gripping member is provided with a plurality of first recesses (23, 25) with sloped distal faces (23a, 25a) and of second recesses (24, 26), and the compressive member is provided with inner radial pegs (45a, 46a), said inner radial pegs (45a, 46a) being engageable with said first recesses and/or second
35 recesses.

8. The adaptor (10) of any one of claims 1 to 7, wherein said gripping member is a lateral clipping member comprising a U-shaped element (21) intended to be engaged on said collar via the open part of the U-shaped element, the curved part of the U-shaped element partially surrounding the collar.

9. The adaptor (10) of any one of claims 1 to 8, further comprising a cleaning pad (60, 160, 260), said cleaning pad being configured to at least partially slide on said outer surface of said septum when the adaptor is being mounted on the medical container.

10. The adaptor (10) of claims 5, 8, and 9, wherein said transversal wall (221) is provided in the direction of free ends of the U-shaped element, with a projection provided with said cleaning pad (260).

11. The adaptor (10) of any one of claims 9 to 10, wherein said cleaning pad (60) is located on a removable part of said adaptor.

12. The adaptor (10) of claim 11, wherein said removable part is a portion (51) of a blister (50) surrounding said adaptor in a storage state.

13. The adaptor (10) of claim 12, wherein the blister (50) is provided with front guiding projection (53).

14. The adaptor (10) of any one of claims 1 to 13, further comprising a pierceable decontamination insert (70) located proximally with respect to said elastomeric piece.

15. The adaptor (10) of any one of claims 1 to 14, wherein the pierceable elastomeric piece is self-resealing.

16. The adaptor (10) of any one of claims 1 to 15, wherein the elastomeric piece is made of a material selected from synthetic polyisoprene, natural rubber, silicone rubber, thermo-plastic elastomers, or the like or a combination thereof.

17. The adaptor (10) of any one of claims 1 to 16, wherein the pierceable elastomeric piece further comprises a material including antiseptic agents, such as silver ions or copper ions.

18. The adaptor (10) of any one of claims 1 to 17, wherein the pierceable elastomeric piece comprises a coating comprising an antiseptic agent, such as chlorhexidine di-acetate.

19. The adaptor (10) of any one of claims 8 to 18, wherein the cleaning pad comprises a disinfecting agent.

20. The adaptor (10) of any one of claims 1 to 19, further provided with a time monitoring system (500, 501, 502).

21. The adaptor (10) of any one of claims 1 to 21, wherein a blister (50) surrounds said adaptor in a storage state, the time monitoring system (500) being capable of being triggered once the adaptor is mounted on the collar of the drug container, by a peg (54) of the blister coming in contact with the time monitoring system when a user applies a distal pressure on a shell (51) of the blister.

22. Assembly comprising a medical container (1) having a collar closed by a septum, said septum having an outer surface directed towards the outside of the medical container, and an adaptor (10) according to any one of claims 1 to 21.

23. The assembly of claim 22, wherein the septum is self-resealing.

ABSTRACT**Adaptor for coupling with a medical container**

The present invention relates to an adaptor (10) for coupling with a vial (1) having a collar (3) closed by a septum (4), said septum having an outer surface directed towards the outside of the vial, the adaptor comprising:

- a gripping member (20) for securing the adaptor to the vial, said gripping member being capable of being laterally mounted on the collar of said vial and

- a pierceable elastomeric piece (30) having at least a part intended to be in contact with the outer surface of the septum when said adaptor is secured on said vial. The invention also relates to an assembly comprising such an adaptor and a vial.

Figure 10A

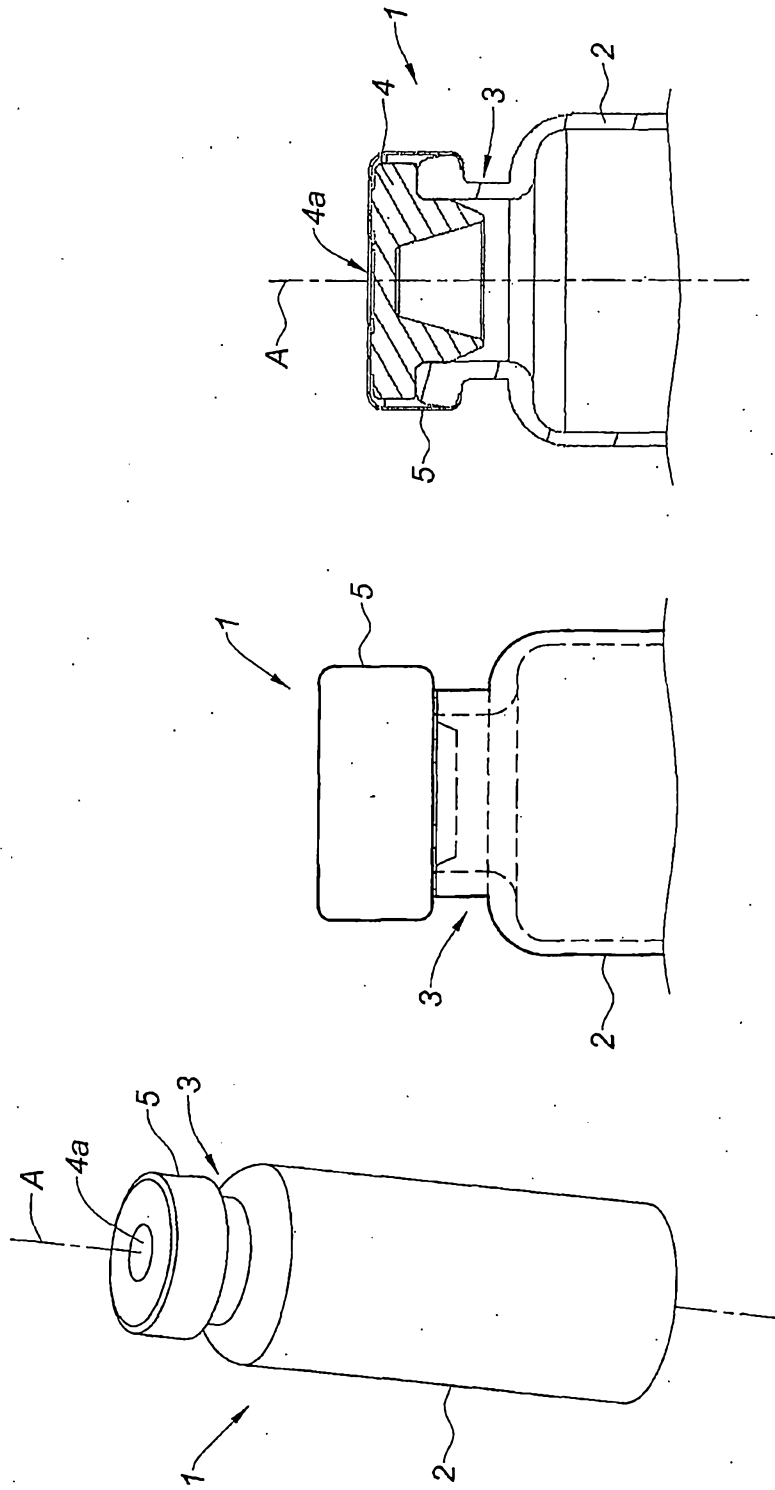

Fig. 1C

Fig. 1B

Fig. 1A

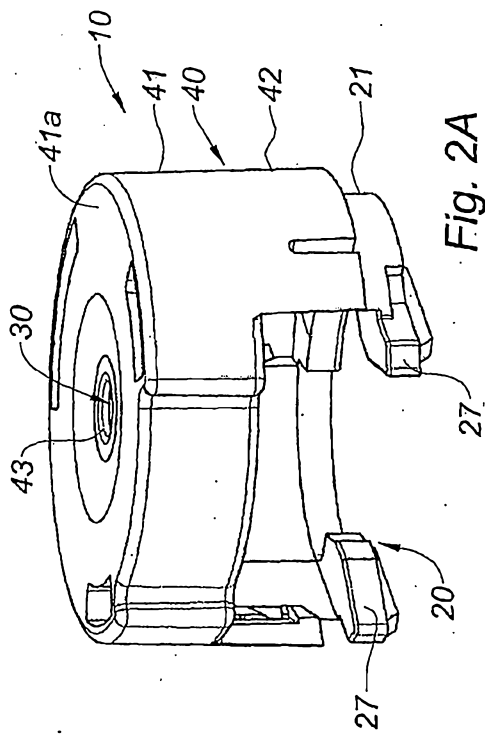

Fig. 2A

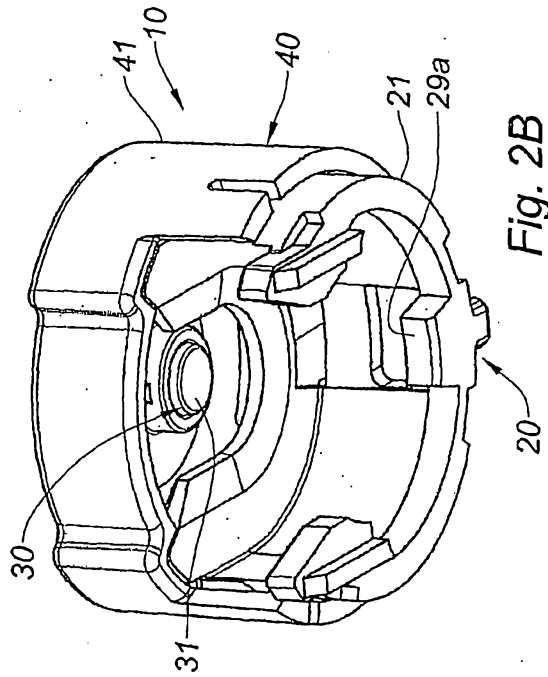

Fig. 2B

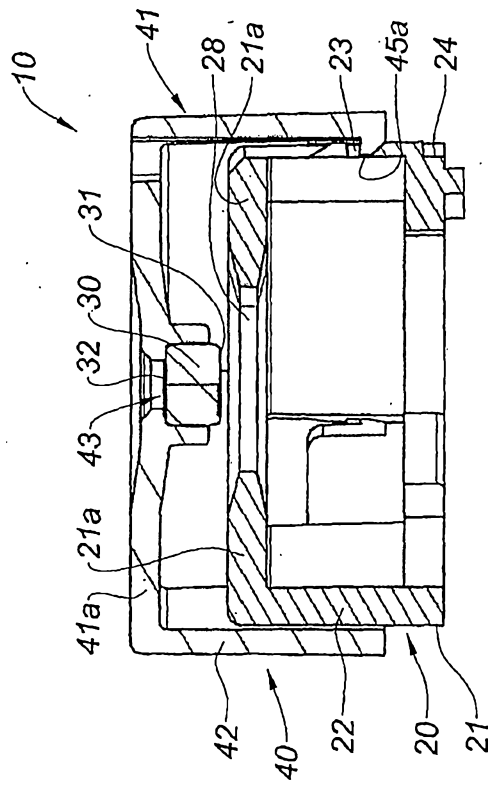

Fig. 2C

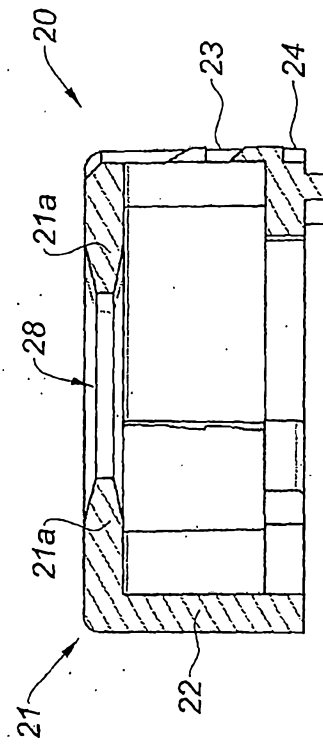
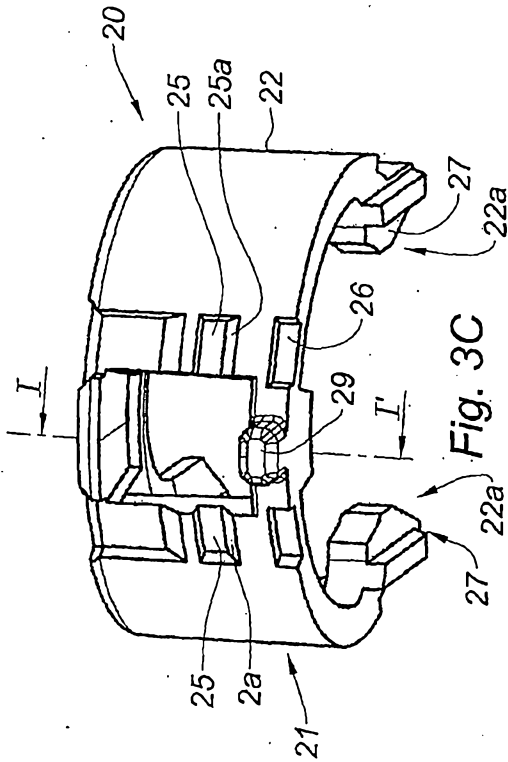

Fig. 3D

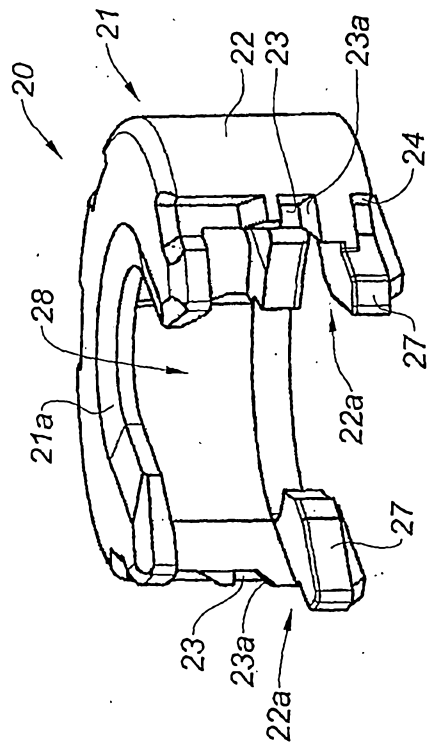

Fig. 3A

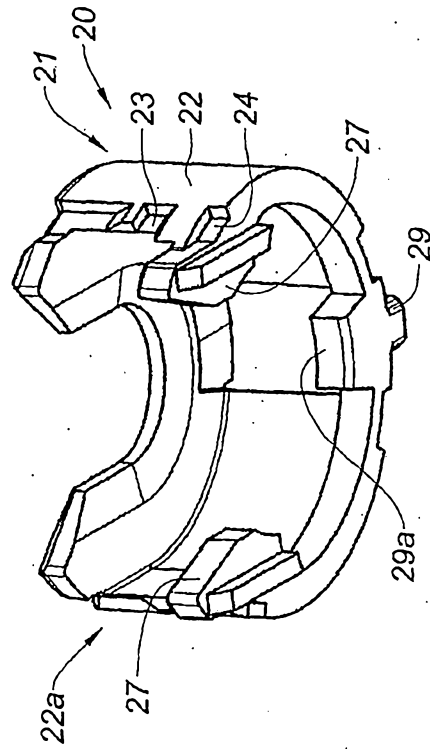

Fig. 3B

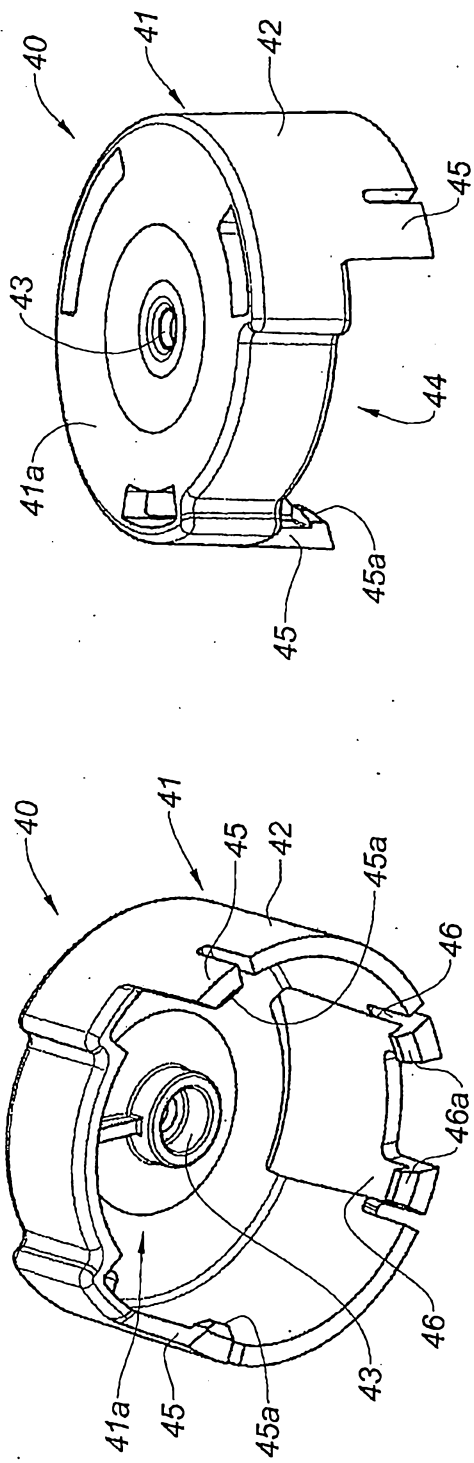

Fig. 4B

Fig. 4A

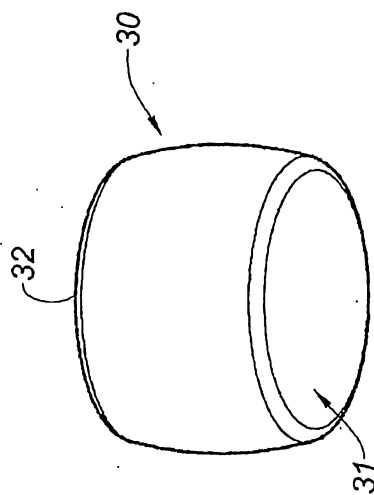

Fig. 5

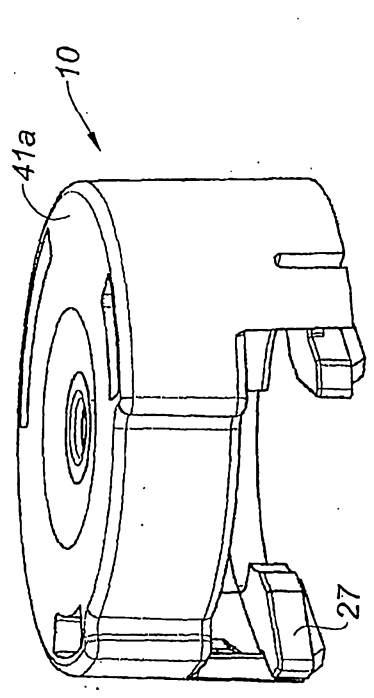

Fig. 6A

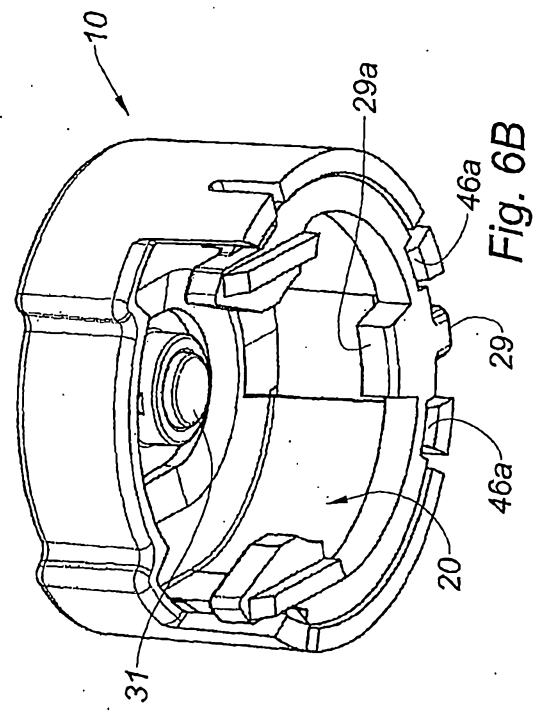

Fig. 6B

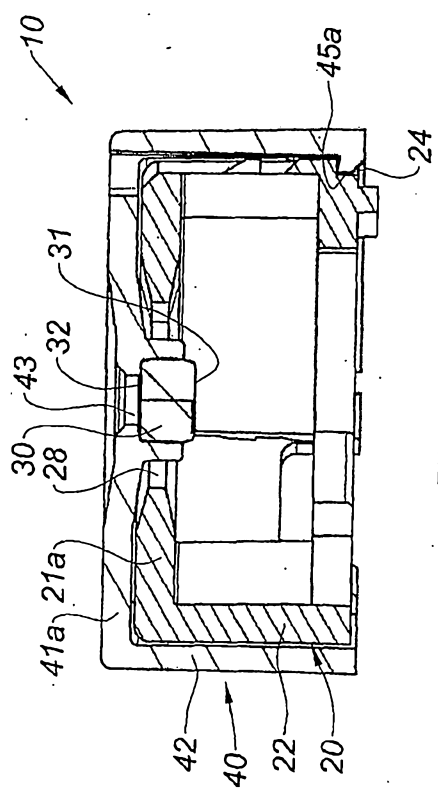

Fig. 6C

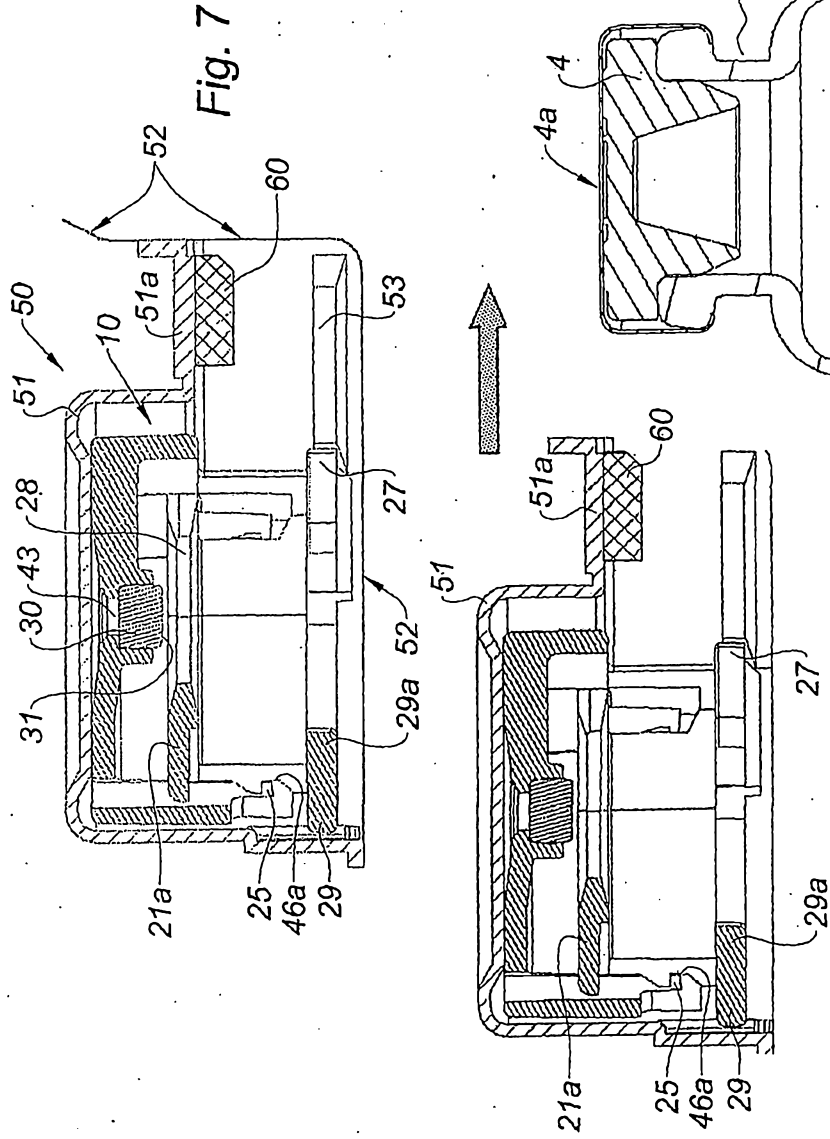

Fig. 7

Fig. 8

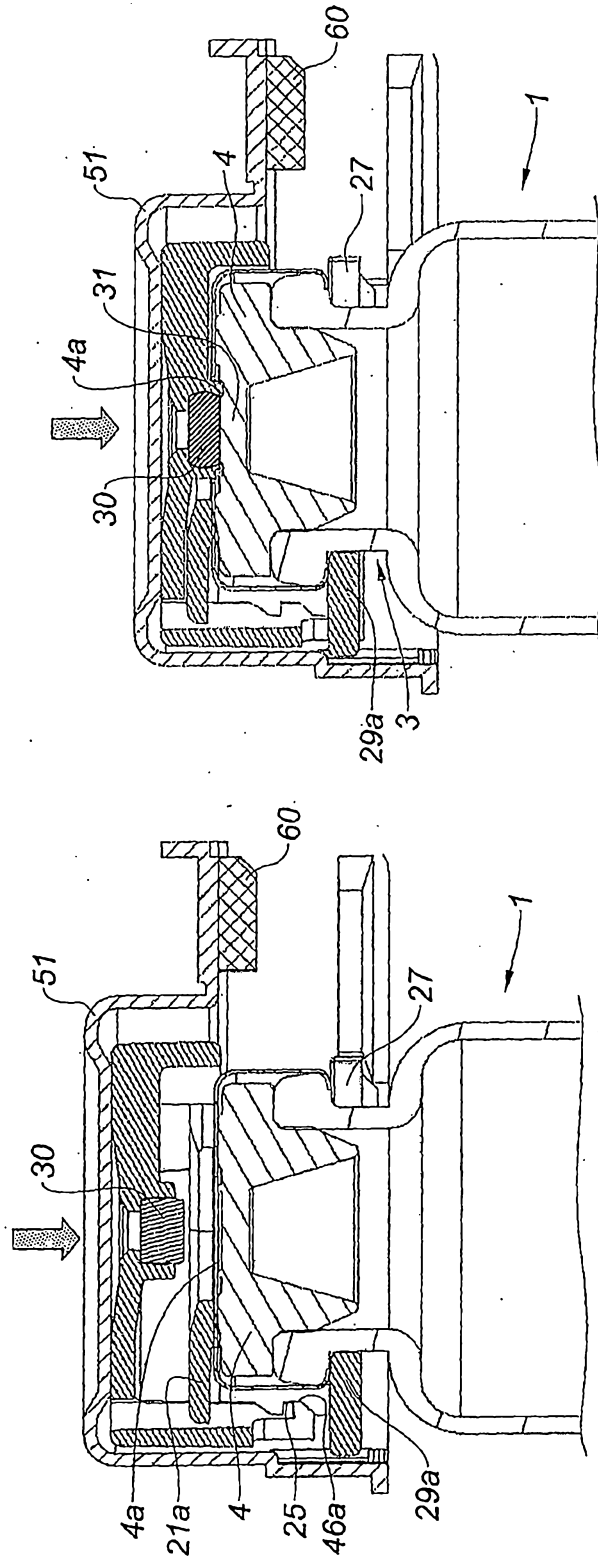

Fig. 9B

Fig. 9A

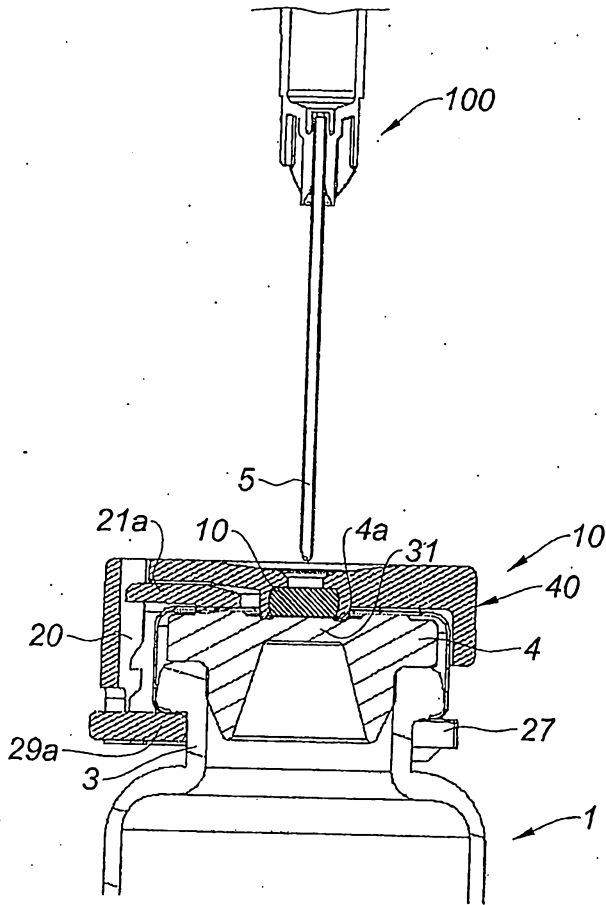

Fig. 10A

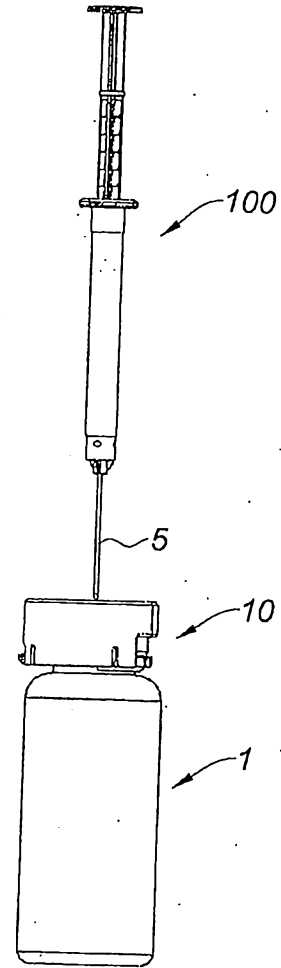

Fig. 10B

9/17

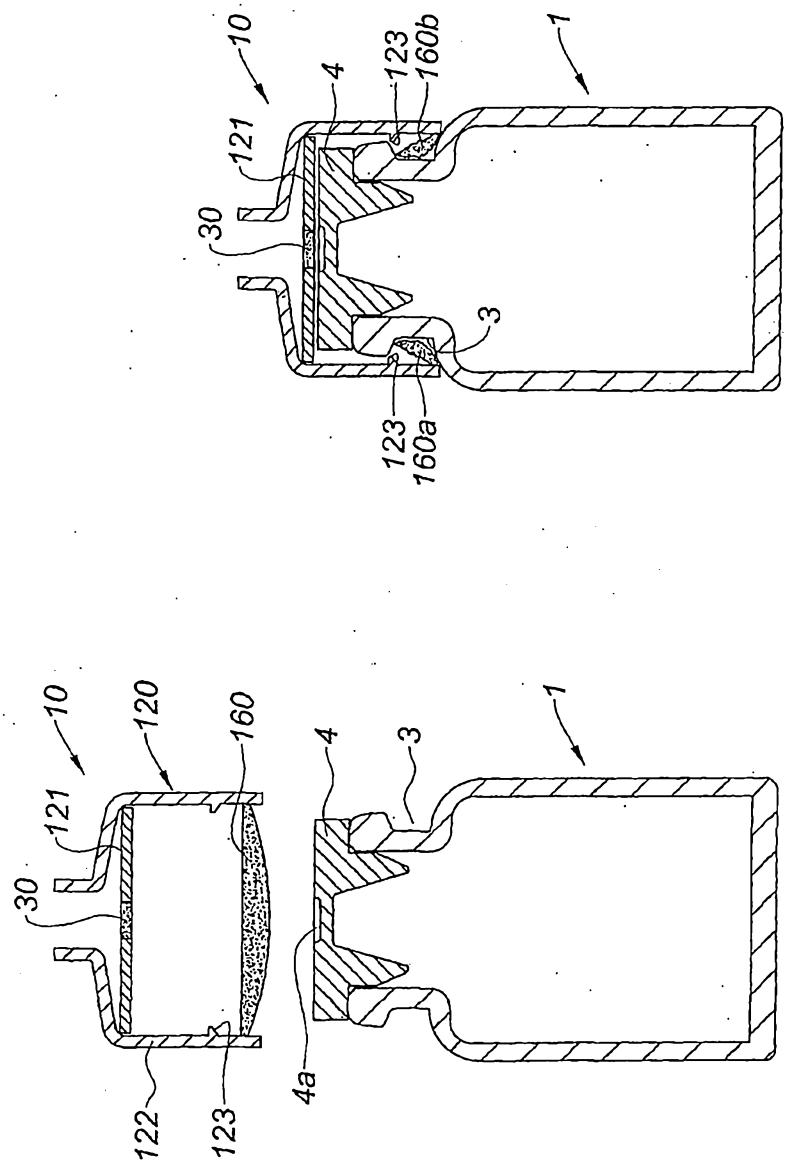

Fig. 11B

Fig. 11A

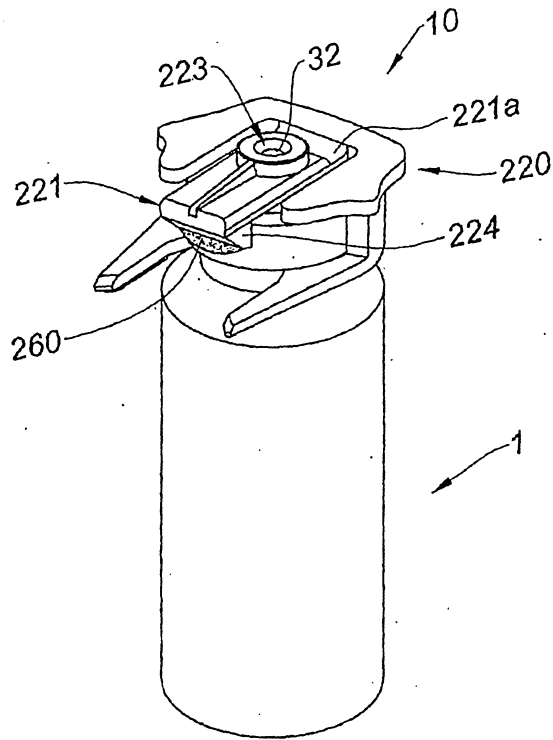

Fig. 12A

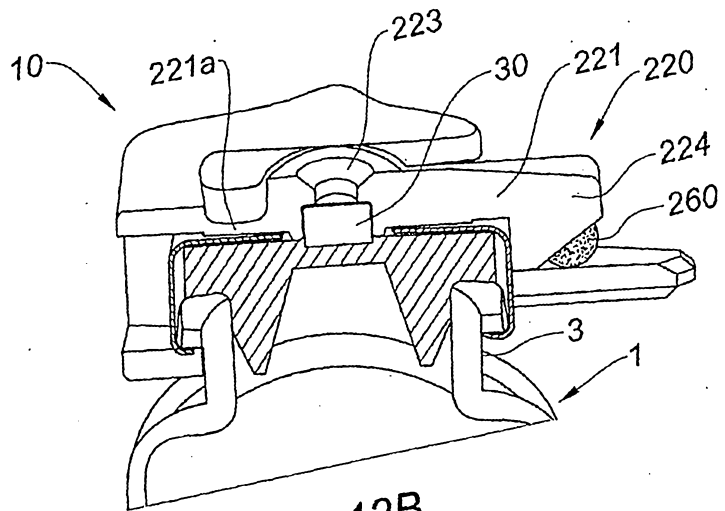

Fig. 12B

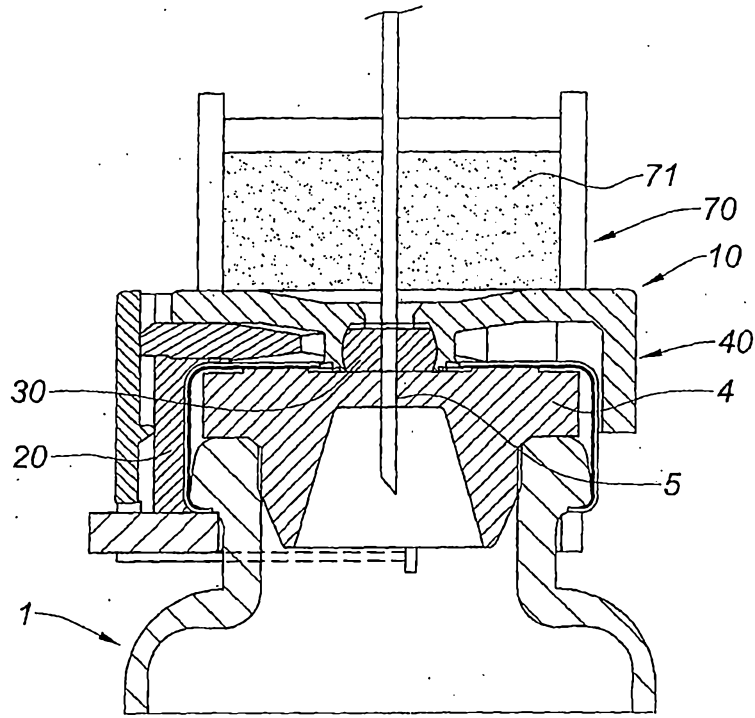

Fig. 13

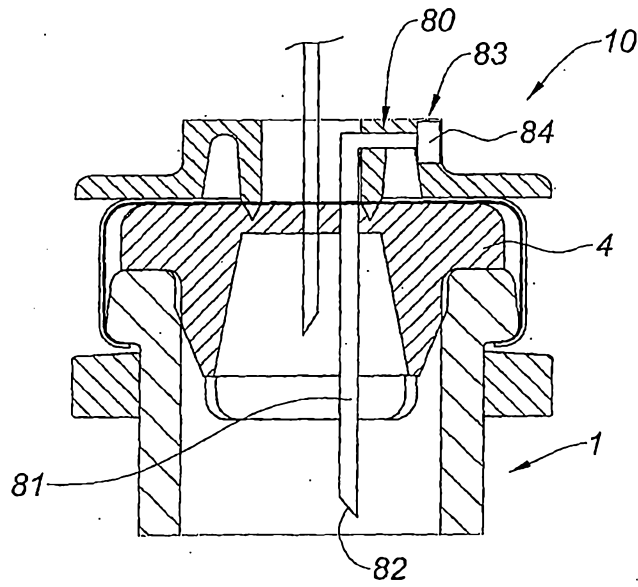

Fig. 14

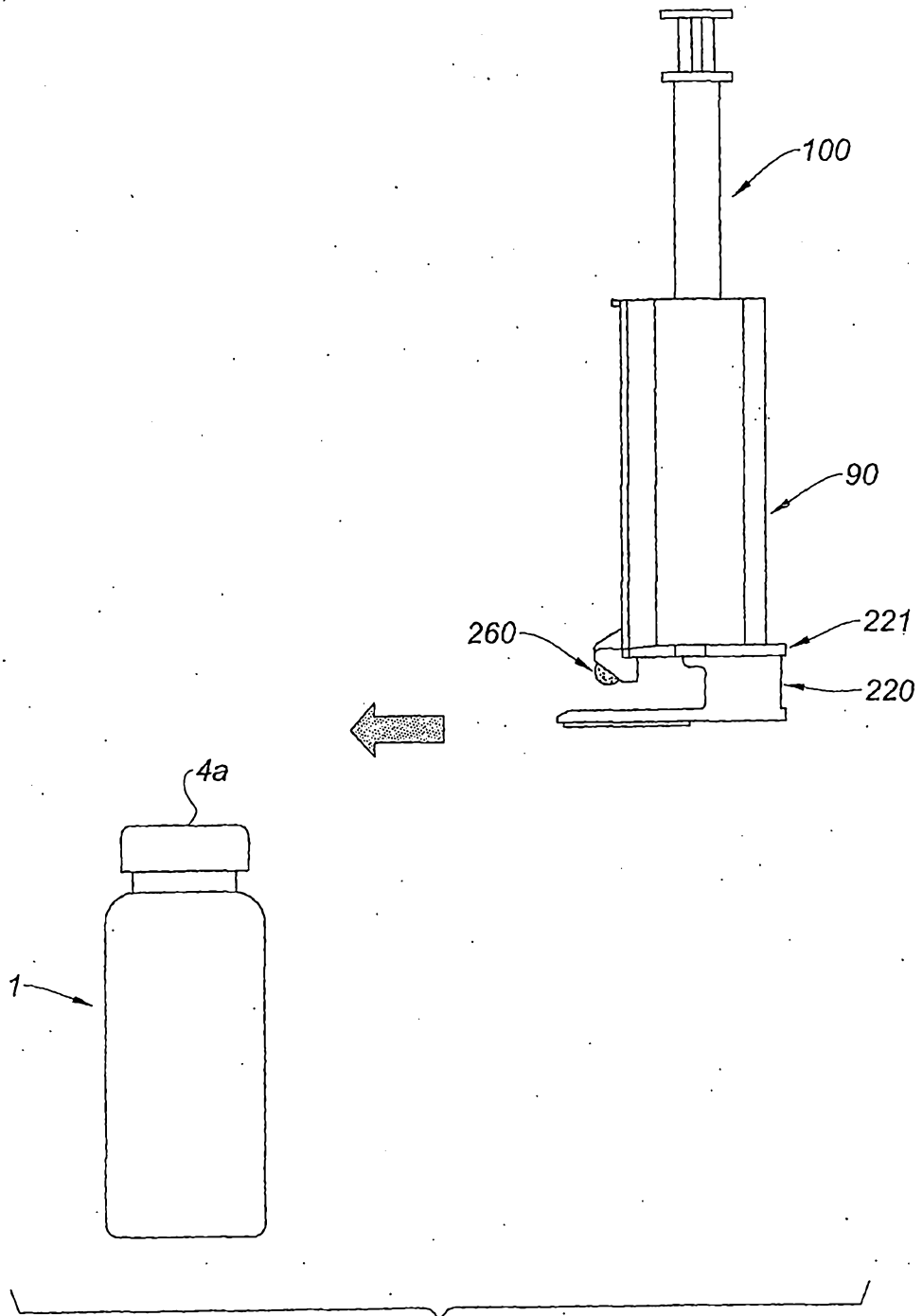

Fig. 15

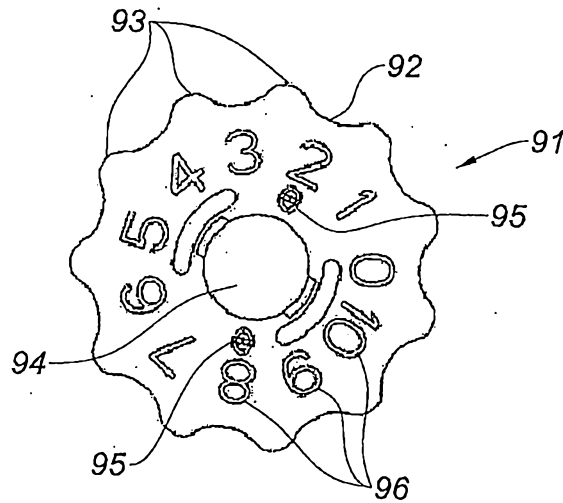
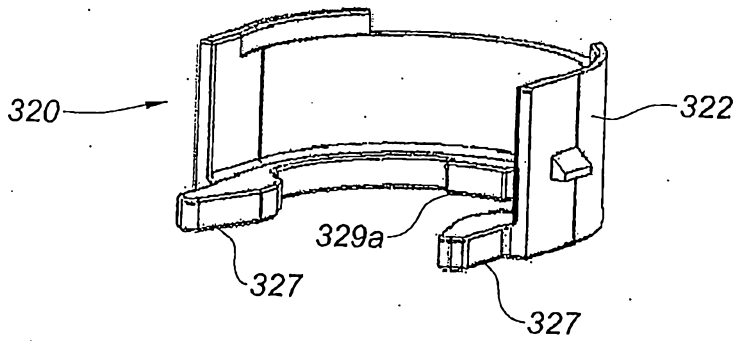
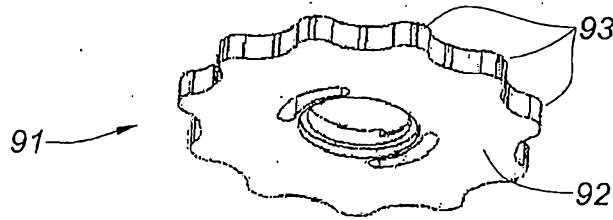
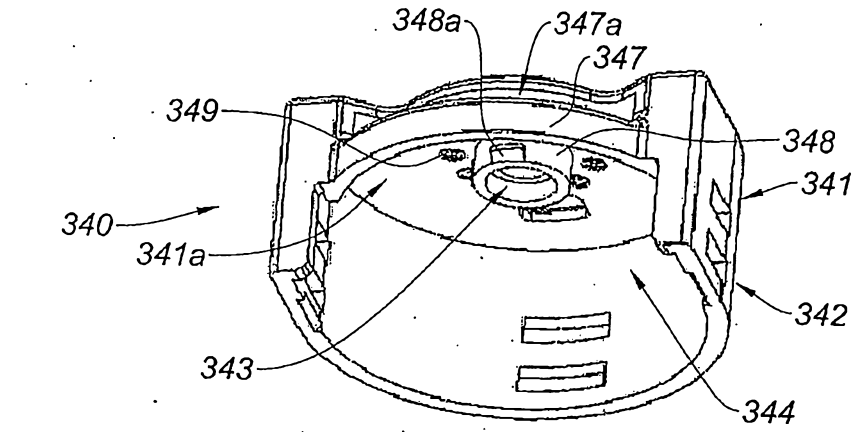

Fig. 16

Fig. 17

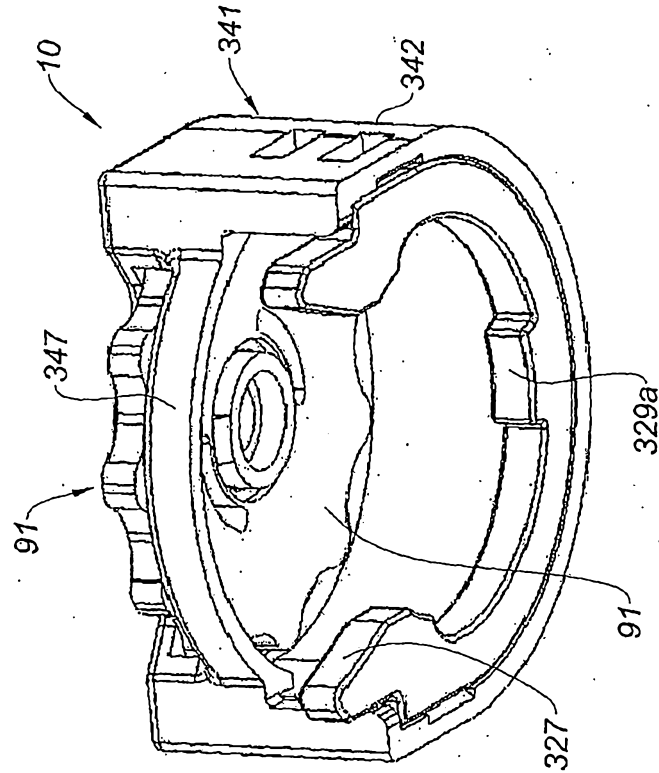

Fig. 18B

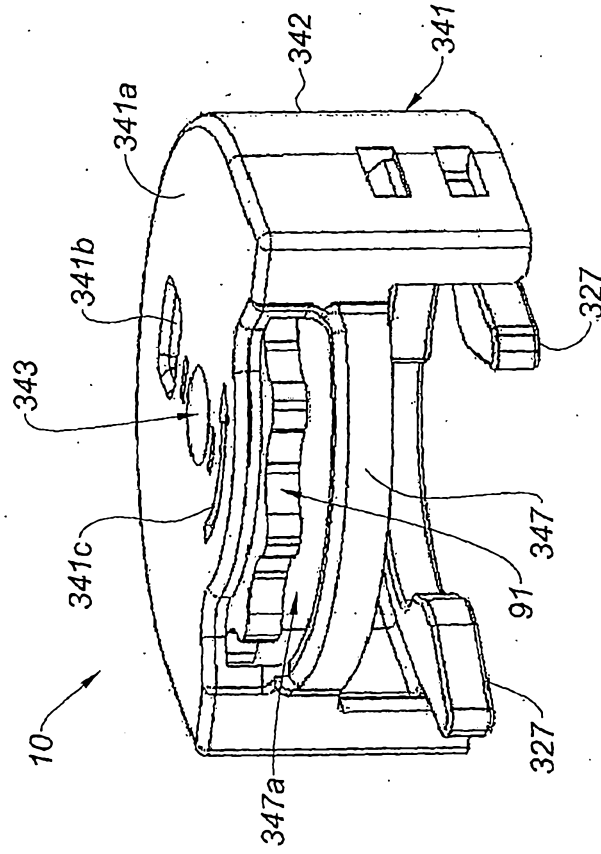

Fig. 18A

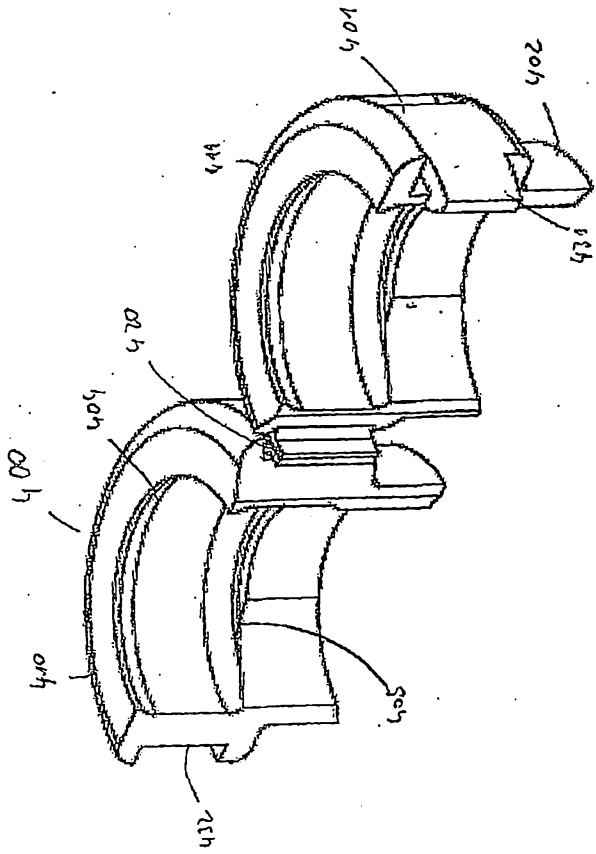

Fig 19.A

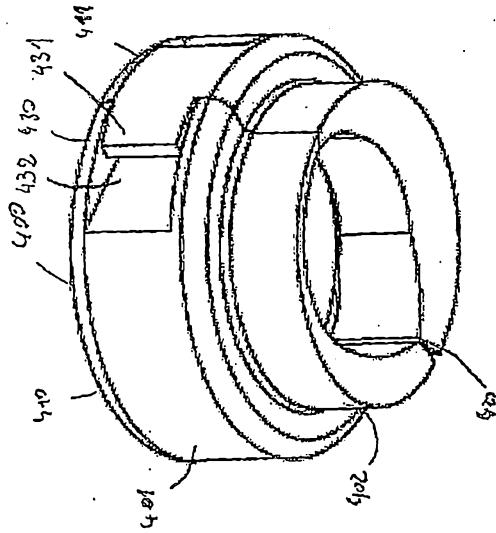

Fig 19.B

16/17

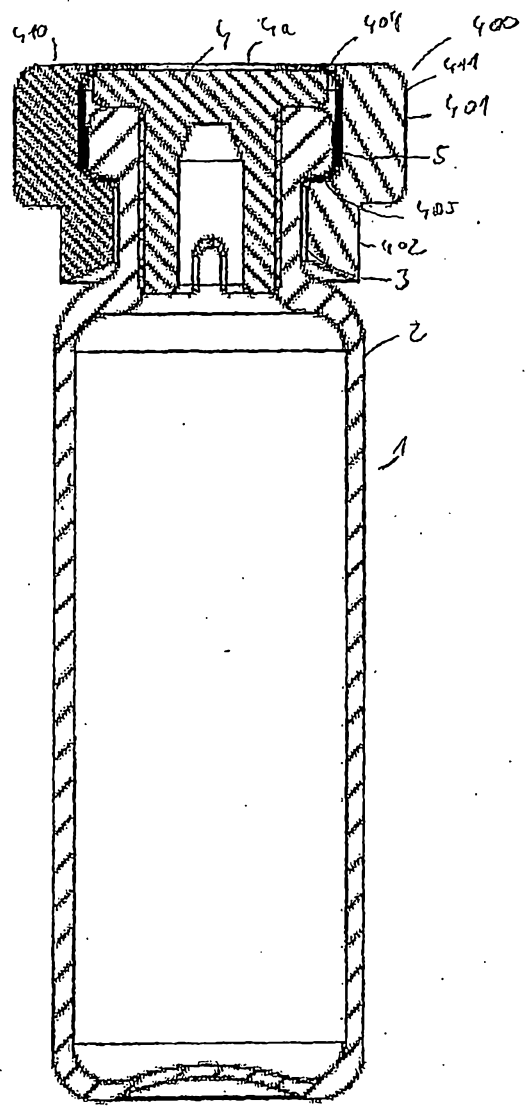

Fig 20

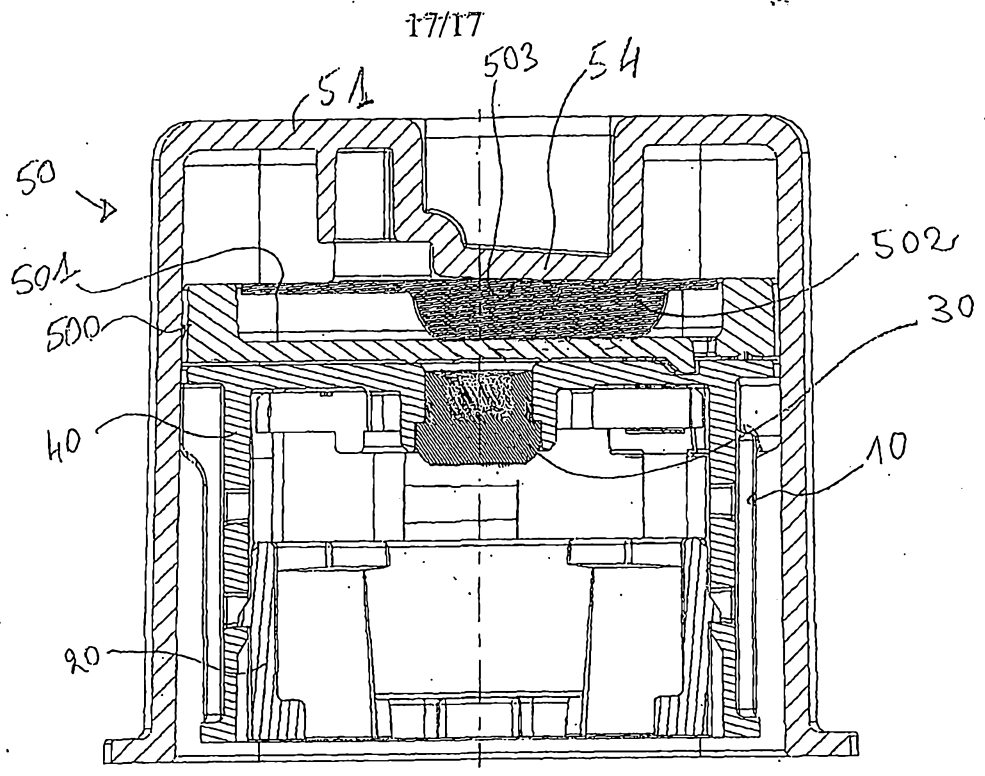

FIG. 21

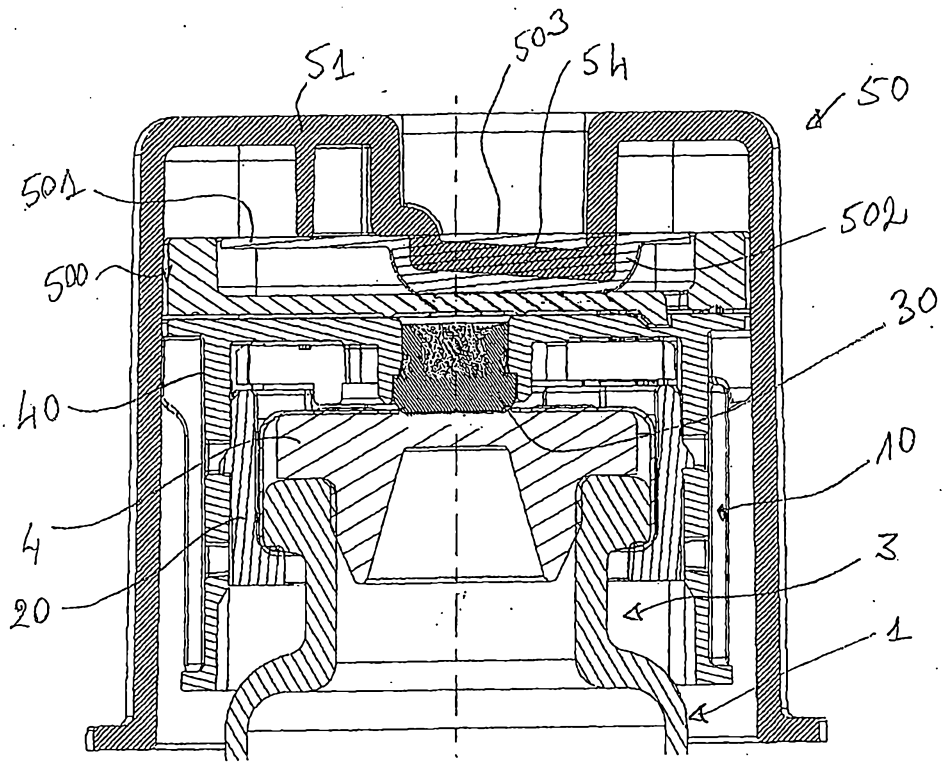

FIG. 22