

(19)



Europäisches Patentamt
European Patent Office
Office européen des brevets



(11)

EP 0 710 618 B2

(12)

NEW EUROPEAN PATENT SPECIFICATION

(45) Date of publication and mention
of the opposition decision:
21.06.2006 Bulletin 2006/25

(51) Int Cl.:
B66B 11/00^(2006.01)

(45) Mention of the grant of the patent:
12.07.2000 Bulletin 2000/28

(21) Application number: **95116984.6**

(22) Date of filing: **27.10.1995**

(54) **Traction sheave elevator**

Antriebsscheibenaufzug

Ascenseur à poulie de traction

(84) Designated Contracting States:
**AT BE CH DE DK ES FR GB GR IE IT LI LU MC NL
PT SE**
Designated Extension States:
LT LV SI

(30) Priority: **03.11.1994 FI 945171**

(43) Date of publication of application:
08.05.1996 Bulletin 1996/19

(73) Proprietor: **Kone Corporation
00330 Helsinki (FI)**

(72) Inventors:
• **Aulanko, Esko
FIN-04230 Kerava (FI)**
• **Mustalahti, Jorma
FIN-05620 Hyvinkää (FI)**
• **Hakala, Harri
FIN-05830 Hyvinkää (FI)**

(74) Representative: **Zipse + Habersack
Wotanstrasse 64
80639 München (DE)**

(56) References cited:
EP-A- 0 686 594 WO-A-95/00432
DE-U- 1 740 974 JP-U- 50 297

EP 0 710 618 B2

Description

[0001] The present invention relates to a traction sheave elevator as defined in the preamble of claim 1.

[0002] One of the objectives in elevator development work has been an efficient and economic utilisation of building space. In conventional traction-sheave driven elevators, the elevator machine room or other space reserved for the drive machinery takes up a considerable portion of the building space needed for the elevator. The problem is not only the volume of the building space needed for the drive machinery, but also its location in the building. There are numerous solutions to the placement of the machine room, but they generally significantly restrict the design of the building at least in respect of space utilisation or appearance. For example, a machine room placed on the roof of a building can be felt to be a flaw of appearance. Being a special space, the machine room generally involves increased building costs.

[0003] A traction sheave elevator with a hoisting unit containing a hoisting motor in the elevator shaft is an advantageous and flexible solution for implementing an elevator. Finnish patent application no. 932977 previously filed by the applicant presents a traction sheave elevator with drive machine above in which the machinery unit and associated equipment are placed substantially above the path of the counterweight. Another Finnish patent application, no. 941719 filed by the applicant, presents a traction sheave elevator with machine room above in which the drive machine unit is placed in the upper part of the elevator shaft between a shaft wall and the space required by the elevator car or an overhead extension of said space. In both of these solutions, the machinery is supported by the wall or ceiling of the elevator shaft. In some cases, mounting the machinery on the wall or ceiling may involve considerable costs, especially if reinforcement of the structures is required. In any case, mounting the machinery on a wall or ceiling involves installation work in the mounting locations, such as drilling holes in the wall or ceiling etc.

[0004] JP utility model publication 4-50297 discloses a machineromless rucksack-type elevator (small type elevator) wherein the drive unit is mounted on the heads of the guide rails. However, as the base surface of the drive machine unit is rather large, a large distance has to be provided between the cabin path and the shaft wall. This necessitates a larger base surface of the elevator shaft and therefore higher investments with respect to the building costs.

[0005] To meet the need to further develop the elevator concept presented in patent applications 932977 and 941719, a new type of traction sheave elevator is presented as an invention. The traction sheave elevator of the invention is characterized by what is presented in the characterization part of claim 1. Other embodiments of the invention are characterized by the features presented in the other claims.

[0006] The advantages provided by the invention in-

clude the following:

- The elevator is advantageous in respect of installation because the vertical forces are transmitted to the building via the guide rails and no separate anchorage of the machine on the building structures is required. The strength of the anchorages fixing the guide rails to the building need not be substantially increased as these anchorages generally have to be of a sufficiently strong design because of the gripping forces.
- The elevator has a construction that is simple to implement. The machinery, machine bed, electric elevator drive, rope anchorage and overspeed governor can be put together in factory to form a single pre-tested assembly.
- A smaller number of points of attachment of the elevator to the building means an easier construction and installation process.
- The traction sheave elevator of the invention allows an obvious space saving to be achieved because no separate machine room is needed.
- The invention allows efficient utilisation of the cross-sectional area of the elevator shaft. There is room for other elevator equipment beside the machinery.
- The machinery can be easily hoisted into position because it can generally be hoisted up together with the guide rails. Placement of the hoist used for the installation of the guide rails and machinery is no problem because the hoisting machinery is located in a lateral part of the shaft. The machinery can easily be lifted up close to the shaft top. The installer has almost unimpeded access to the machinery so that he can set and fix the machinery in position and perform other installation operations required.

[0007] In the following, the invention is described in detail by the aid of an application example by referring to the attached drawing, in which

Fig. 1 shows a diagrammatic representation of a traction sheave elevator according to the invention.

[0008] A traction sheave elevator as provided by the invention is presented in Fig. 1 in diagrammatic form. The elevator car 1 and counterweight 2 are suspended on the hoisting ropes 3 of the elevator. The hoisting ropes 3 support the elevator car 1 substantially centrally or symmetrically with respect to the vertical line passing via the centre of gravity of the elevator car 1. Similarly, the suspension of the counterweight 2 is substantially centric or symmetric relative to the vertical line going through the centre of gravity of the counterweight. However, symmetric suspension of the elevator car and/or counterweight is not a condition for implementing the invention but only a preferred solution in connection with its implementation. In Fig. 1, the elevator car 1 is supported by the hoisting ropes 3 by means of diverting pulleys 4 pro-

vided with rope grooves (only one diverting pulley is shown in the figure), and the counterweight 2 is supported by a grooved diverting pulley 9. The diverting pulleys 4 preferably rotate substantially in the same plane. The hoisting ropes 3 generally consist of several ropes placed side by side, usually at least three ropes. The drive machine unit 6 of the elevator with a traction sheave 7 engaging the hoisting ropes 3 is placed in the top part of the elevator shaft.

[0009] The elevator car 1 and the counterweight 2 travel in the elevator shaft along elevator and counterweight guide rails 10, 11, 11a which guide them. The elevator and counterweight guides holding the elevator car and counterweight on the guide rails are not shown in the figure.

[0010] In Fig. 1, the hoisting ropes 3 run as follows: One end of the hoisting ropes is fixed to an anchorage 13 above the path of the counterweight 2 in the top part of the shaft. From the anchorage 13, the ropes go downwards until they meet a diverting pulley 9 rotatably mounted on the counterweight 2. Having passed around the diverting pulley 9, the ropes 3 go again upwards to the traction sheave 7 of the drive machine 6, passing over it along rope grooves. From the traction sheave 7 the ropes go downwards to the elevator car 1, passing under it via the diverting pulleys 4 supporting the elevator car 1 on the ropes and continuing upwards to an anchorage 14 in the top part of the shaft, where the other end of the ropes 3 is fixed. Preferably at least one of the anchorages 13, 14 in the top part of the shaft is in the beam 20.

[0011] The machine unit 6 placed in the elevator shaft is of a flat construction as compared to its width, including the equipment that may be needed for the supply of power to the motor driving the traction sheave 7 as well as the necessary elevator control equipment, both of said equipments 8 being mounted in conjunction with the machine unit 6, possibly integrated with it. All essential parts of the machine unit 6 and the associated equipments 8 are supported by the upper end of guide rail 11a. The machine unit may also be supported by the upper ends of other guide rails. In this context, 'upper end of the guide rail' may refer to the top face of the guide rail or to that longitudinal portion of the guide rail which the guide moving along the guide rail does not reach in its top position. Especially applicable is a solution which comprises a beam 20 resting on the top end faces of two elevator guide rails 11, 11 a. Such a beam 20 acts as a machine bed on which the machine unit 6, the equipment unit 8 containing the electric drive of the elevator, the rope anchorage 13 of the hoisting ropes and the overspeed governor (not shown in the figure) are mounted to form a single aggregate.

[0012] The drive machine unit 6 generally has to be fastened to the elevator shaft by means of a bracing element 21 that takes up horizontal forces but substantially does not take up any vertical supporting forces. The vertical forces are transmitted to the building via the guide rails, so the load is transmitted to the building by the guide rail anchorages at the bottom end of the rails and also

by the rail clips. The bracing element 21 may consist e.g. of a bracket made from a metal plate and attached by one end to the drive machine unit and by the other end to the wall or ceiling of the shaft. A simple bracing element is a screw or the like. Even the guide rail anchorages can be used to provide the required lateral bracing. Since the centre of gravity of the elevator machinery and the point of application of the rope forces are usually not directly above the supporting points of the elevator machinery as it stands on its bed, it follows that the machinery may get into various rocking modes of vibration. By using a separate bracing element 21, holding possible rocking of the machinery in check is considerably cheaper and simpler than if the beam and its anchorage were to be made rigid enough to render separate horizontal bracing unnecessary.

[0013] It is obvious to a person skilled in the art that different embodiments of the invention are not restricted to the examples described above, but that they may instead be varied within the scope of the claims presented below. For example, the number of times the hoisting ropes are passed between the top part of the elevator shaft and the counterweight or elevator car is not very decisive with regard to the basic advantages of the invention, although it is possible to achieve some additional advantages by using multiple rope stretches. It is also obvious that the hoisting ropes need not necessarily be passed under the car, or that the machinery may be mainly supported by both counterweight and elevator guide rails.

[0014] It is also obvious to the skilled person that the elevator car, counterweight and machine unit can be laid out in the cross-section of the elevator shaft in a way differing from the above examples. For instance, in a ruck-sack type elevator, both ends of the hoisting ropes could advantageously be fixed to the beam acting as a machine bed if the rope suspension arrangement requires that both ends be fixed.

[0015] Furthermore, it is obvious to the skilled person that the equipment required for the supply of power to the motor and the equipment needed for the control of the elevator can be placed elsewhere except in conjunction with the machine unit 6, e.g. in a separate control panel. Similarly, it is obvious that an elevator implemented according to the invention can be equipped in a way differing from the examples described.

Claims

1. Traction sheave elevator comprising an elevator car (1) moving along elevator guide rails (10), a counterweight (2) moving along counterweight guide rails (1-1), a set of hoisting ropes (3) on which the elevator car and the counterweight are suspended, and a drive machine unit (6) comprising a traction sheave (7) driven by the drive machine and engaging the hoisting ropes (3), whereby the drive machine unit

(6) is placed in the top part of the elevator shaft in the space between the shaft space needed by the elevator car on its path and/or an overhead extension of said space and a wall of the elevator shaft, and whereby the drive machine unit (6) is mounted on the upper end of one or more guide rails (10, 11, 11a), **characterized in that** the drive machine unit (6) is fastened to the elevator shaft by means of a bracing element (21) that takes up horizontal forces acting on the drive machine unit (6) but substantially does not take up any vertical supporting forces.

2. Traction sheave elevator according to claim 1, **characterized in that** the drive machine unit (6) is supported by a beam (20) constituting a machine bed, mounted on the upper end of two guide rails.
3. Traction sheave elevator according to any one of the preceding claims, **characterized in that** the machine unit (6), the equipment unit (8) containing the electric drive of the elevator, the rope anchorage (13) of at least one end of the hoisting ropes and the over-speed governor are mounted on the machine bed (20), forming a single aggregate.
4. Traction sheave elevator according to one of the preceding claims, **characterized in that** the drive machine unit (6) is of a flat construction as compared to its width.
5. Traction sheave elevator according to one of the preceding claims, **characterized in that** the drive machine unit (6) has a traction sheave (7) which is arranged parallel to the plane of the counterweight (2).

Patentansprüche

1. Antriebsscheibenaufzug mit einer Aufzugskabine (1), welche sich entlang von Aufzugsführungsschienen (10) bewegt, einem Gegengewicht (2), welches sich entlang von Gegengewichtsführungsschienen (11) bewegt, einem Satz Hubseile (3), an welchem die Aufzugskabine und das Gegengewicht aufgehängt sind, und einer Antriebsmaschineneinheit (6), welche eine Antriebsscheibe (7) aufweist, die von der Antriebsmaschine angetrieben ist und mit den Hubseilen (3) in Eingriff steht, wobei die Antriebsmaschineneinheit (6) im oberen Bereich eines Aufzugsschachtes im Raum zwischen dem von der Aufzugskabine auf ihrem Weg benötigten Schachtraum und/oder einer oberen Erweiterung dieses Raumes und einer Wand des Aufzugsschachtes angeordnet ist, und die Antriebsmaschineneinheit (6) am oberen Ende einer oder mehrerer Führungsschienen (10, 11, 11a) befestigt ist,

dadurch gekennzeichnet,

daß die Antriebsmaschine (6) an dem Aufzugsschacht mittels eines Verstrebungselements (21) befestigt ist, welches zur Aufnahme horizontaler auf die Antriebsmaschineneinheit (6) wirkender Kräfte ausgebildet ist, welches aber im wesentlichen keine vertikalen Stützkkräfte aufnimmt.

2. Antriebsscheibenaufzug nach Anspruch 1, **dadurch gekennzeichnet,** **daß** die Antriebsmaschineneinheit (6) von einem Träger (20) getragen wird, welcher ein Maschinenbett ausbildet, das am oberen Ende von zwei Führungsschienen angeordnet ist.
3. Antriebsscheibenaufzug nach einem der vorangehenden Ansprüche, **dadurch gekennzeichnet,** **daß** die Antriebsmaschineneinheit (6), die Ausrüstungseinheit (8) mit dem elektrischen Antrieb für den Aufzug, die Seilverankerung (13) für mindestens ein Ende der Hubseile sowie der Geschwindigkeitsbegrenzer auf dem Maschinenbett (20) angeordnet sind und dabei ein einzelnes bzw. einziges Aggregat bilden.
4. Antriebsscheibenaufzug nach einem der vorangehenden Ansprüche, **dadurch gekennzeichnet,** **daß** die Antriebsmaschineneinheit (6) im Vergleich zu ihrer Breite flach gebaut ist.
5. Antriebsscheibenaufzug nach einem der vorangehenden Ansprüche, **dadurch gekennzeichnet,** **daß** die Antriebsmaschineneinheit (6) eine Antriebsscheibe (7) aufweist, welche parallel zur Ebene des Gegengewichts (2) angeordnet ist.

Revendications

1. Ascenseur à poulie de traction comprenant une cabine d'ascenseur (1) se déplaçant le long de rails de guidage d'ascenseur (10), un contrepoids (2) se déplaçant le long de rails de guidage de contrepoids (11), un ensemble de câbles de levage (3) sur lequel la cabine d'ascenseur et le contrepoids sont suspendus, et une machine d'entraînement (6) comportant une poulie de traction (7) entraînée par la machine d'entraînement et en prise avec les câbles de levage (3), dans lequel la machine d'entraînement (6) est placée dans la partie supérieure de la cage d'ascenseur, dans l'espace défini entre l'espace de cage qui est nécessaire à la cabine d'ascenseur sur son trajet, et/ou un prolongement supérieur dudit espace, et une paroi de la cage d'ascenseur, et dans lequel la machine d'entraînement (6) est montée sur l'extré-

- mité supérieure d'un ou plusieurs rails de guidage (10, 11, 11a), **caractérisé en ce que** la machine d'entraînement (6) est fixée à la cage d'ascenseur au moyen d'un élément de liaison (21) qui reprend les forces horizontales agissant sur la machine d'entraînement (6) mais qui ne reprend sensiblement pas de forces de support verticales. 5
2. Ascenseur à poulie de traction selon la revendication 1, **caractérisé en ce que** la machine d'entraînement (6) est supportée par une poutre (20) constituant un socle de machine, montée sur l'extrémité supérieure de deux rails de guidage. 10
3. Ascenseur à poulie de traction selon une quelconque des revendications précédentes, **caractérisé en ce que** la machine (6), l'équipement (8) contenant la commande électrique de l'ascenseur, l'ancrage de câble (13) d'au moins une extrémité des câbles de levage et le régulateur de survitesse sont montés sur le socle de machine (20) de manière à constituer un groupe unique. 15
20
4. Ascenseur à poulie de traction selon une quelconque des revendications précédentes, **caractérisé en ce que** la machine d'entraînement (6) est de construction plate comparativement à sa largeur. 25
5. Ascenseur à poulie de traction selon une quelconque des revendications précédentes, **caractérisé en ce que** la machine d'entraînement (6) comprend une poulie de traction (7) qui est disposée parallèlement au plan du contrepoids (2). 30

35

40

45

50

55

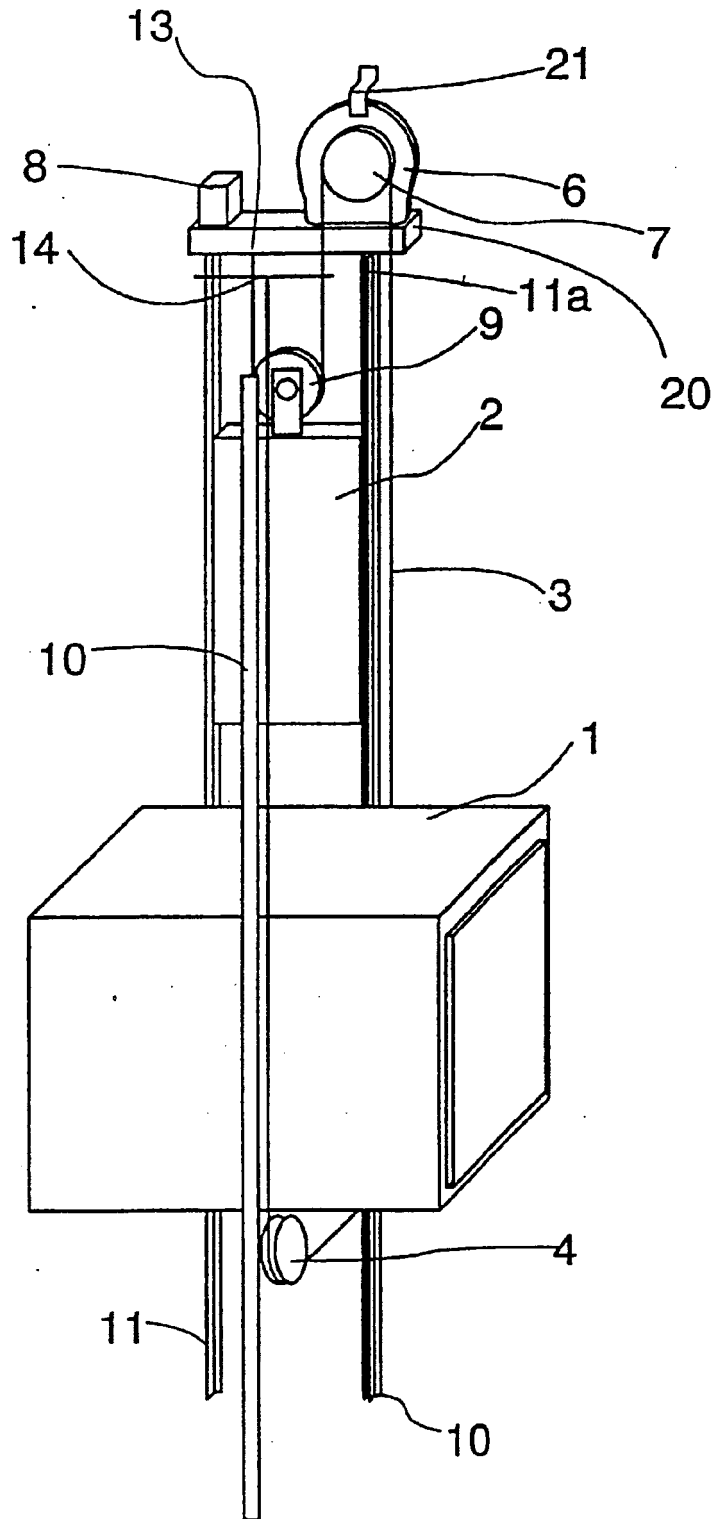

Fig. 1