

J. McCOY.
Hot Air Furnace.

2 Sheets—Sheet 1.

No. 106,708.

Patented Aug. 23, 1870.

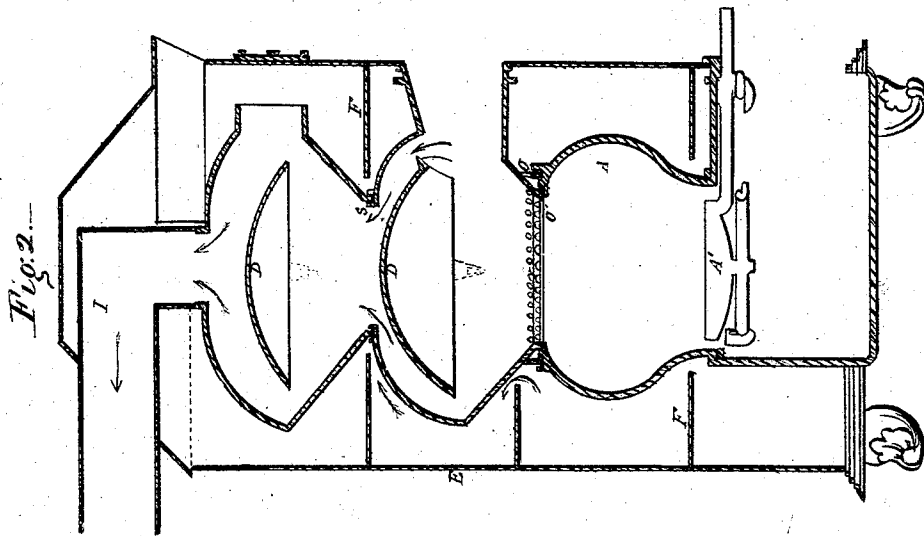
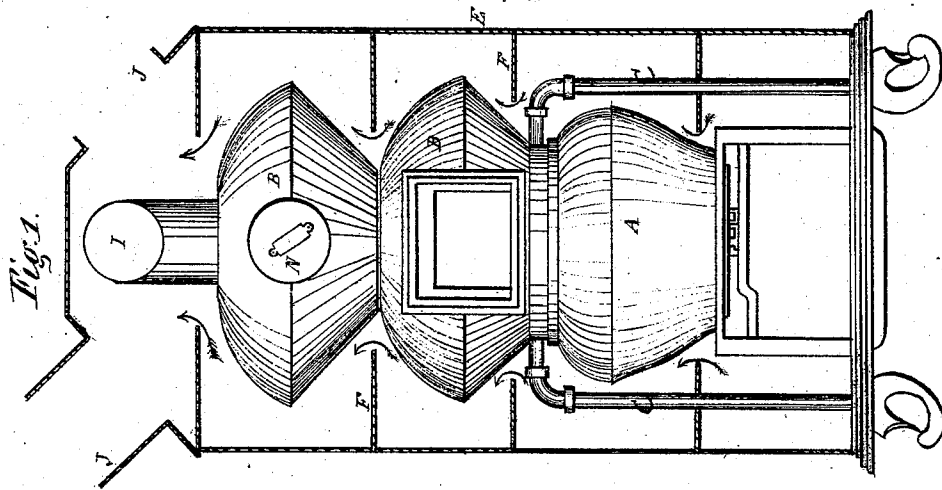

Witnesses
Wm. H. Dennis
W. Dennis

Inventor
John McCoy
By his Atty J. Dennis

J. McCOY.

Hot Air Furnace.

No. 106,708.

Patented Aug. 23, 1870.

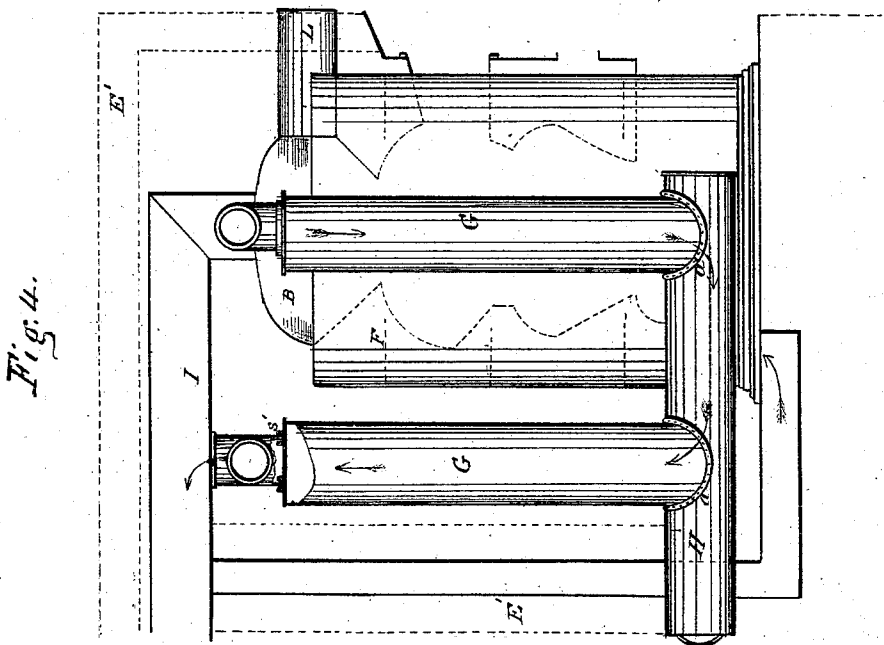
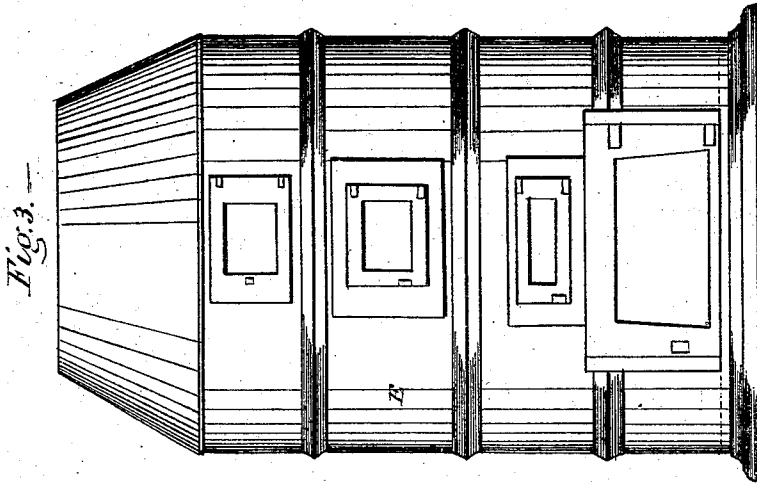

Witnesses

Wm. H. Dennis.
Wm. Dennis

Inventor.

John McCoy
By his Atty. J. Dennis Jr

United States Patent Office.

JOHN McCOY, OF BURLINGTON, NEW JERSEY, ASSIGNOR TO HIMSELF AND CARBON STOVE COMPANY.

Letters Patent No. 106,708, dated August 23, 1870.

HOT-AIR FURNACE.

The Schedule referred to in these Letters Patent and making part of the same

To all whom it may concern:

Be it known that I, JOHN McCOY, of Burlington city and county, in the State of New Jersey, have invented certain new and useful Improvements in Heating Furnaces; and I hereby declare the following to be a full and exact description thereof, reference being had to the accompanying drawing forming part of this specification.

The nature or essence of my invention consists in an improved method of constructing and arranging certain parts of a heating furnace, as will be fully set forth in the description and claims here following.

In the drawing hereinbefore mentioned—

Figure 1, sheet 1, is a front elevation of fire-pot and connected parts;

Figure 2, a vertical section of the same, taken at right angles to the view in fig. 1;

Figure 3, sheet 2, is a front view of the surrounding case, shown in section in figs. 1 and 2; and

Figure 4 is an elevation of drums and pipes arranged outside the above-mentioned case.

The cast-iron fire-pot A is provided with a grate, A', and surmounted by the drums B, of which there may be such a number as may be thought desirable.

The one next above A I use as a combustion-chamber, and cast on its lower edge two flanges, o, a short distance apart, to fit corresponding flanges on the top of the fire-pot A, so as to form at this point a circular air-chamber or hollow space around the contracted neck or top of the fire-pot.

These flanges o may be short, as shown in the drawing, admitting only one or two rows of air-openings through the inner flange, or extended in height sufficiently to admit of the introduction of all the air that may be found necessary for a thorough ignition of the combustible gases that may pass through the contracted neck of the furnace.

The top of the fire-pot A is contracted, for the especial purpose of compelling the gases that may arise from the fuel to pass in contact with air that is introduced through the perforated wall that incloses the neck or throat of the furnace, formed, as stated, by the inner flange o.

The circular chamber or hollow space formed by concentric walls or flanges, as stated, is supplied with air by the pipes C, and perforations or notches are made in the inner flange or wall of the furnace neck, as shown at r, so as to allow the air to pass freely into the neck of the furnace, to aid the complete combustion of the products from the burning fuel below.

The drums B are made of much larger diameter at the middle part than at the top and bottom, as shown, and are each cast whole, or in one piece, the construction heretofore employed in casting them in two or more pieces, and connecting them by bolts or rivets,

having been found objectionable, as the alternate contraction and expansion of the metal by heating and cooling soon spoiled the joints. They are connected together by setting the lower edge of each between two flanges, cast on the upper edge of the one below, the joint being made tight by filling the remaining space between the flanges with sand, fire-clay, or other suitable material.

Within these drums are placed circular deflectors D, supported on feet or otherwise, which compel the moving current or draught from the fire to follow the zigzag course of the surface of the drums, and keep it in close contact therewith, instead of allowing it to pass up chiefly through the center of the drums. In this way the drums are more efficiently heated.

The drums B and fire-pot A are surrounded by a case, E, preferably of galvanized sheet-iron, to the interior of which are attached horizontal deflectors F, which project into the recesses formed by the peculiar shape of the fire-pot and drums, as shown.

The air to be heated being admitted into the bottom of the case E, it is compelled, in rising, to follow the zigzag course of the exterior of the fire-pot and drums, and to pass over every part of their exterior surface, and in close contact with it.

In this way a much greater amount of heat is communicated to the rising current than if it was allowed to pass up free, as in that case much the larger portion of it would not enter these recesses at all.

To increase the heating surface I arrange within the brick chamber containing the drums B, indicated on fig. 4, by dotted lines at E', the vertical drums G, outside the case E, and connect them with each other by the horizontal drums or pipes H, and to the drums B by the smoke or draught-flue I, which is to be provided with a suitable valve for closing or stopping the direct draught, and compelling it to pass through these outer drums.

The openings on the horizontal drums H, as at a and a', are provided with double flanges, the lower edge of the vertical drums G being set between the inner and outer flange, as in the case of the drums B, and shown at s, fig. 2, and the tops of the drums G are provided with similar double flanges, by means of which they are connected with the pipes leading into or out of them, as shown at s', fig. 4.

These flanges are filled with sand, to make a tight joint, and this arrangement and form or method of connection has the important advantage that the drums and pipes can be set up or taken down by a servant or common laborer without the assistance of a skilled workman.

The pipes H are made to extend through the wall of the brick chamber, and provided with a removable stopper, so as to be readily cleaned out from the outside, and the drums B may be provided with a clean-

out pipe, L, arranged in like manner, and provided with a stopper, N.

When inclosed in a brick chamber, the case E will, of course, be open at the top, but by covering it, as shown in figs. 1, 2, and 3, an efficient portable furnace will be formed, the heated air being conveyed to its destination by a pipe or pipes, J; or, if it be desirable to keep the heat in as much as possible, there may be two cases, an outer one with cover on it, as shown in the figures just referred to, and an inner one open at the top, as shown in fig. 4, with the deflectors F attached to it.

I claim as my invention—

1. The combination, with a series of drums, B, of the horizontal deflectors F, attached to a surrounding case, and arranged to project into the recesses formed by the drums, substantially as described.

2. Forming an air-chamber around the neck or throat of the furnace, by means of flanges, cast on the fire-pot, or on the drum surmounting it; or on both, substantially as and for the purpose set forth.

3. The fire-pot A, with its contracted top, in combination with a neck or throat more or less elongated, and having around it an air-chamber with a perforated inner wall, substantially as and for the purpose specified.

4. The combination and arrangement of the fire-pot A, drums B, case E, supporting the deflectors F, and the outer radiating drums G and H, to form a heating furnace, substantially as herein set forth.

JOHN MCCOY.

Witnesses:

JNO. CHURCHMAN,

J. M. ROBERTS.