

(19)



Europäisches Patentamt

European Patent Office

Office européen des brevets



(11)

EP 0 956 793 A2

(12)

EUROPEAN PATENT APPLICATION

(43) Date of publication:  
17.11.1999 Bulletin 1999/46

(51) Int. Cl.<sup>6</sup>: A47C 3/026, A47C 1/032

(21) Application number: 99107348.7

(22) Date of filing: 21.04.1999

(84) Designated Contracting States:  
AT BE CH CY DE DK ES FI FR GB GR IE IT LI LU  
MC NL PT SE  
Designated Extension States:  
AL LT LV MK RO SI

(72) Inventor: Donati, Armando  
25067 Lumezzane (BS) (IT)

(74) Representative:  
Marietti, Giuseppe  
MARIETTI e GISLON S.r.l.  
Via Larga, 16  
20122 Milano (IT)

(30) Priority: 27.04.1998 IT MI980894

(71) Applicant: Donati S.p.A.  
25040 Camignone (BS) (IT)

(54) A tiltable support for chair

(57) An inclinable support for chairs, oscillating or synchronized armchairs and similar furniture has a device of regulation of the suspension and of the seat inclination, by means of setting an inclination spring (8), that comprises: at least one inclined surface (14) between a fixed part (13) and a mobile part (10) in contact with the extremity of the said spring; at least one

wedge (12) interposed between the fixed part and the mobile part with at least one inclined surface (15) complementary to and matching the inclined surface (14); and means for moving said wedge to cause said fixed and mobile parts to separate or come together.

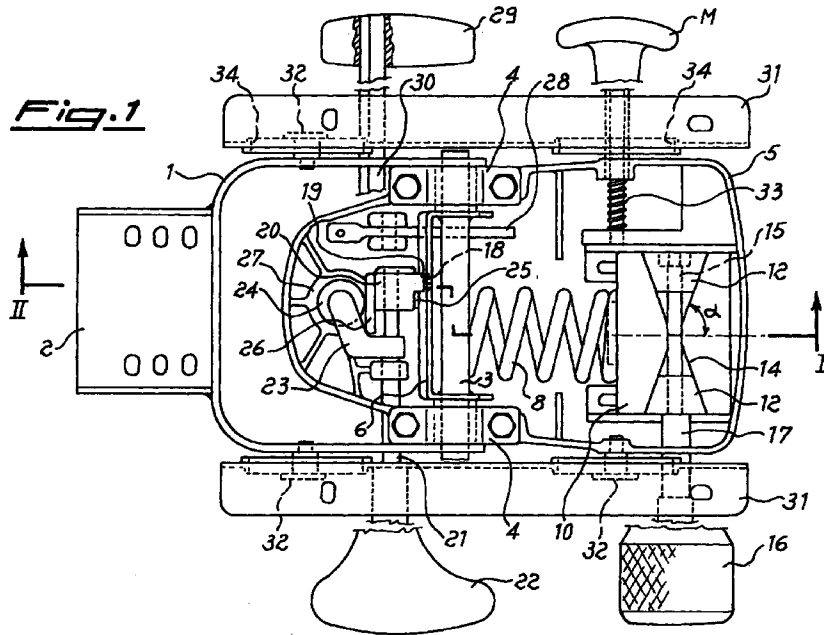

EP 0 956 793 A2

## Description

[0001] The invention relates to an inclinable support for oscillating or synchronized chairs and armchairs, having a device for regulating the suspension and the inclination.

[0002] In the following description the term chair also is intended to designate armchairs, in particular office armchairs, and any similar furniture. The term synchronized is applied to chairs and armchairs in which the angle of oscillation of the back is different from that of the seat; the term oscillating is applied to chairs and armchairs in which seat and back tilt with the same angle.

[0003] State of the art chairs and armchairs are known where the seat and the back are linked, or synchronized in their movements, and they can be inclined simultaneously to allow the user to regulate the inclined position of the back and of the seat. There is a device in the more advanced embodiments for setting the spring resistance to inclination i.e. the force required by the user to tilt the chair.

[0004] One type of known mechanism, using an externally controlled screw, generally by means of a knob or wheel, located frontally under the seat. The wheel moves the anchor point of the spring to compress or release the same inside the support for the chair. To resist the stresses of the imposed load, the screw has a sufficiently large thread but this provides a not considerable pitch. The principal disadvantage of these embodiments is that the rotation of the screw requires quite a lot of effort and since the pitch is large it is not possible to make fine adjustments to the screw settings.

[0005] Another disadvantage arises by the known mechanisms don't allow the inclination of the position of departure (zero position) of the seat and of the back to be regulated in such a way as to allow the user to achieve the sitting position most suitable to his own physical requirements.

[0006] It is a purpose of the present invention to resolve the aforementioned problems, and to propose a support for a chair equipped with a seat/back inclination adjustment device that allows fine adjustment with reduced effort.

[0007] A further purpose of the present invention is to also allow the user to regulate the starting position of the inclination.

[0008] Such purposes are achieved by the present invention which relates to an oscillating support for inclinable chairs characterized according to Claim 1.

[0009] According to a preferential embodiment of the present invention, the inclined surface(s) of the said regulating device for setting the spring are flat.

[0010] According to another aspect of the invention, the setting regulation device of the spring comprises two opposed wedges with at least one inclined surface each, joined to the said fixed part or to the said mobile part. Preferably, the two wedges present two inclined

surfaces each, joined to the fixed part and to the mobile part respectively.

[0011] According to another embodiment of the invention, the inclined surfaces present a mirror image angle of inclination about a common reference line.

[0012] According to a further aspect of the invention, the support further comprises a housing to which the back is fixed securely. The inclination spring acts on the back through the said housing directly or through an oscillating arm rigidly connected to the said housing and the oscillating arm comprises a slot which can be engaged by a spacer to set the zero position of the chair.

[0013] According to another aspect of the invention, the spacer is endowed with a nose to engage the slot and with side prominences to engage the oscillating arm in two positions.

[0014] The inclinable support for oscillating or synchronized chairs according to the present invention presents the following advantages: the regulation of the setting of the spring can be fine adjusted due to the reducing effect of the wedge mechanism on the rotation imparted to the setting screw of said mechanism.

[0015] The screw thread can be coarse pitched to support the stress imposed by the spring and by use; at the same time, the reduction (in mechanical effort) introduced by the inclined surfaces of the wedge mechanism reduces the effort which must be applied manually to the screw to effect the operation of regulation of the setting of the spring.

[0016] Furthermore, the presence of the spacer acting on the oscillating arm allows to have two starting positions (zero positions) for the oscillation of the chair. The position with the nose of said spacer in a slot of the oscillating arm results in an advanced position of the back; the support of the said nose on the side of the oscillating arm results in a more reclined position of the back as the starting position for the oscillation of all the chair.

[0017] The invention will now be described in more detail by way of illustration and not of limitation, making reference to the attached drawings in which:

- Fig. 1 is a plan view of the complete mechanism of the chair, having a fine regulation of the setting of the spring and the regulation of the starting point of the oscillation;
- Fig. 2 is the II-II section of figure 1 with the wedge device in the least-loaded position and the back advanced;
- Fig. 3 is the II-II section of figure 1 with the wedge device in the maximum-loaded position and the back slightly reclined.

[0018] As shown in Figure 1, the support for the chair comprises a fork 1, equipped with base 2 of attachment to the back (not shown). The fork oscillates on the transversal pivot 3 by means of the rotation supports 4 with

which the body 5 of the support is provided.

[0019] An arm 6 oscillating within the body 5 is rigidly connected to pivot 3, and carries a reaction pivot 7, shown in figures 2 and 3, for spring 8 that regulates the effort necessary for the inclination of the chair. There is also provided a stop pivot 9 on arm 6, located on the part most distant from the axis of rotation of arm 6. Pivot 9 has the function of engaging rack 28 (fig.1), commanded from the outside by means of lever 29 and rod 30 to stop the chair in the desired inclined position.

[0020] Figure 2 also shows a bush 35 joined to reaction pivot 7 and acting as a housing for the mobile extremity 36 of spring 8. The spring 8 is joined at the other extremity to the regulation device by means of the spring adjuster according to the present invention.

[0021] Such device has a fixed part 13 rigidly connected with body 5 and a mobile part 10 on which an extremity of spring 8 is coupled. According to the invention the fixed part or the mobile, or both parts, has a surface 14 inclined with respect to the axis of spring 8 (which coincides with the right portion of the II-II section line outlined in fig. 1). Between the fixed part 13 and mobile part 10 is arranged at least one wedge 12 also having an inclined complementary surface matching the surface of the fixed and/ or mobile part. The wedge or wedges are mobile along an axis that is substantially perpendicular to the axis of spring 8. Due to the surface 14 the movement of wedges 12 is converted to the movement of mobile part 10 along the axis of spring 8.

[0022] In the preferred embodiment shown, there are two flat inclined surfaces 14 both on fixed part 13 and on mobile part 10 and there are two wedges 12, each with two flat inclined surfaces 14. Wedges 12 are slidable on inclined and converging surfaces 14 of fixed part 13 and mobile part 10 under the action of screw 15, which is operated from the outside via the knob 16 and rotating rod 17. Preferably, the inclined surfaces provide a mirror-image angle of inclination with respect to a common reference line.

[0023] The angle  $\alpha$  of inclination of the surfaces (fig.1) is between 85 and 65 degrees and is preferably around 80 degrees.

[0024] The device according to the invention comprises means also to regulate the so-called "zero position," or starting position, of the inclination. To such end the oscillating arm 6 is engaged by means of the slot 18 with the nose 19 of a spacer 20. The nose 19 has a side prominence 25 and is transversely mobile on pivot 21, operated from the outside by means of lever 22. At its rear, the spacer is in contact with shelf 26 of the boss 27 attached to the chair support column 24.

[0025] When nose 19 is inserted into slot 18, the spacer 20 is in contact with arm 6 by means of side prominence 25 that abuts the arm beside the said slot. When the nose is not lodged in the slot the nose abuts arm 6.

[0026] By means of pivot 21, lever 22 also commands the finger lever 23 driving the damper, adjustable in

height, located in the chair support column 24.

[0027] The support mechanism for chair presents, finally, L-shaped irons 31 for fixing the seat (not shown). Irons 31 are coupled in an oscillating way via pivots 32 and 33 to fork 1 and to body 5; pivot 33 is controlled from the outside via knob M. The L-shaped irons have slots 34 to allow the horizontal shift of the seat with respect to the back.

[0028] The support according to the invention operates as follows: the user, acting on knob 16 and, therefore, on screw 15 brings together or separates wedges 12 of the mechanism: the position of reaction of spring 8 is thus consequently modified, changing the elastic characteristics and therefore the setting. More particularly, in the configuration shown in Figures 1 and 2 the wedges 12 are at their maximum distance and spring 8 is in its widest configuration (i.e. set for the least effort of oscillation). Rotating knob 16 and screw 17 two wedges 12 are drawn together and simultaneously mobile part 10 is moved away from fixed part 13, compressing spring 8 as shown in Fig. 3. In this configuration spring 8 is set for a greater oscillation force.

[0029] The rotation action of the user is mediated by the inclined surfaces 14 of the wedges and of the fixed part 10 and mobile part 13 of the mechanism: this action is smoother, both in terms of the direct effort on the part of the user and in the search for a position more suited to his requirements.

[0030] The angle  $\alpha$  of the inclination of the surfaces can reach 85 degrees giving a strong amplification effect of the fineness of regulation and smoothness of actuation.

[0031] The regulation of the starting position of the oscillation is achieved by shifting spacer 20 transversely to the support for the oscillating chair upon pressure on pivot 21 through the lever 22.

[0032] The spacer has two positions: the first, corresponding to Figures 1 and 2, where the nose 19 is housed in the slot 18 in oscillating arm 6, and a second position, visible in figure 3, where nose 19 leans externally against said arm 6, after a translation of pivot 21 toward lever 22.

[0033] The second position is attainable after the user has inclined the chair so as to allow the disengagement of nose 19 from slot 18 and permit the translation of pivot 21.

[0034] The forces exerted by the oscillating arm to the body are not transmitted via pivot 21, but are transferred directly by spacer 20 to shelf 26 and onto rib 11.

[0035] The horizontal regulation of the seat position is achieved by operating knob M which controls the spring loaded disengagement pivot 33 and the L-shaped irons can then run with their slots 34 on the pivots 32 and 33 of fork 1 and body 5. When the desired position is reached the user releases the knob that blocks, under the action of the spring wound on pivot 33, the sliding of said L-shaped irons and therefore of the seat with respect to the back.

[0036] The Inclined surfaces 14, other than flat as shown in the Figures, could be achieved by constant curvature, cylindrical, or varying, elliptical or with other types of curve, for determine a variation in behavior on the basis of the position of the interposed wedges, with the object of compensating the increase of the elastic reaction of the spring during compression.

### Claims

1. An inclinable support for oscillating or synchronized chair, having an oscillation spring (8) and a regulating device to regulate the force necessary to incline said chair by setting of said spring (8), characterized by said regulating device comprising a fixed part in contact with the said support; a mobile part (10) in contact with the extremity of the said spring (8); at least one first surface (14,15) inclined with respect to the axis of said spring (8) located on said fixed part and/or on said mobile part; at least one wedge (12) with at least one second complementary inclined surface that matches said first inclined surface and a screw (15) or analogous means of moving said wedge against said first inclined surface.
2. A support according to Claim 1, wherein said first and second inclined surfaces are plane.
3. A support according to Claim 1 or 2, wherein said fixed part (13) and said mobile part (10) have inclined surfaces.
4. A support according to any previous Claim, comprising two opposed wedges (12) each having at least one inclined surface (14) matched to said fixed part (13) and/or to said mobile part (10), said wedges being movable one towards the other.
5. A support according to the preceding Claim, wherein said fixed part (13) and said mobile part (10) have two inclined surfaces (14) with angle of inclination mirror-image with respect to a common straight reference line and wherein said wedges have two inclined surfaces matching said fixed and mobile parts.
6. A support according to any previous Claim, further comprising a housing (2) for said back, an oscillating arm (6) rigidly connected to said center (2) and coupled with said oscillation spring (8): a slot (18) located on said oscillating arm (6); a stop spacer (20) mobile parallel to the direction of the axis of oscillation.
7. A support according to the previous claim, wherein said spacer has a nose (19) fitting into said slot to engage said arm (6) in two different positions.
8. A support according to any previous Claim, further comprising a column adjustable in height (24) and a finger lever (23) for the regulation in height of the said adjustable column (24), the said spacer (20) being movable by a pivot (21) which controls the said finger lever.
9. A support according to any previous claim, comprising shaped-irons (31) supporting the seat, provided with slots (34) and sliding on pivots (32, 33) connected to a fork (1) and to said body (5), wherein one (33) of the said slide pivots of the shaped-irons (31) of support of the seat is axially mobile, commanded from the outside (M), against the action of a spring, to allow the stop of the horizontal slide of the said shaped-irons.
10. An oscillating or synchronized chair, characterized by comprising a support according to an any of the previous claims.

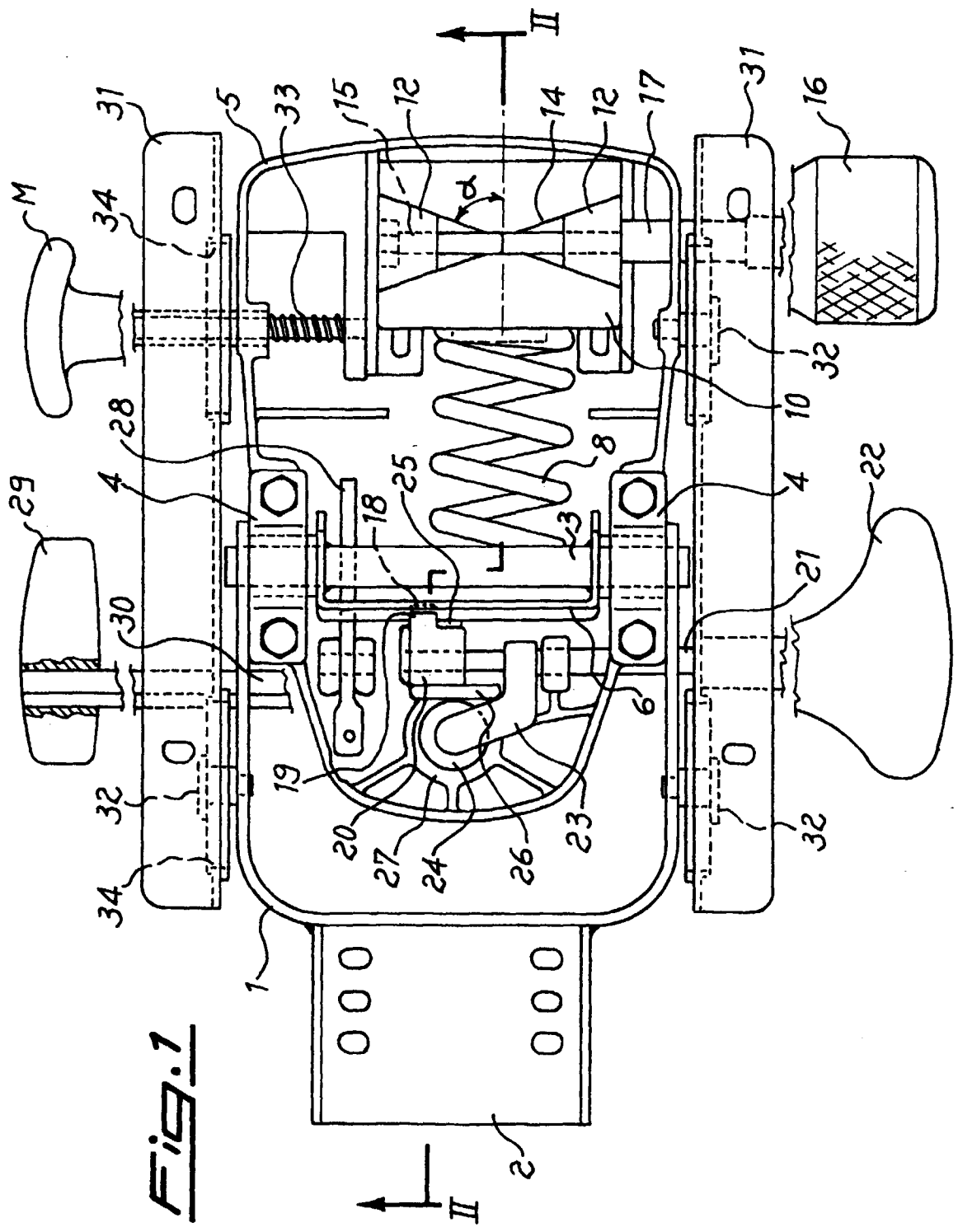
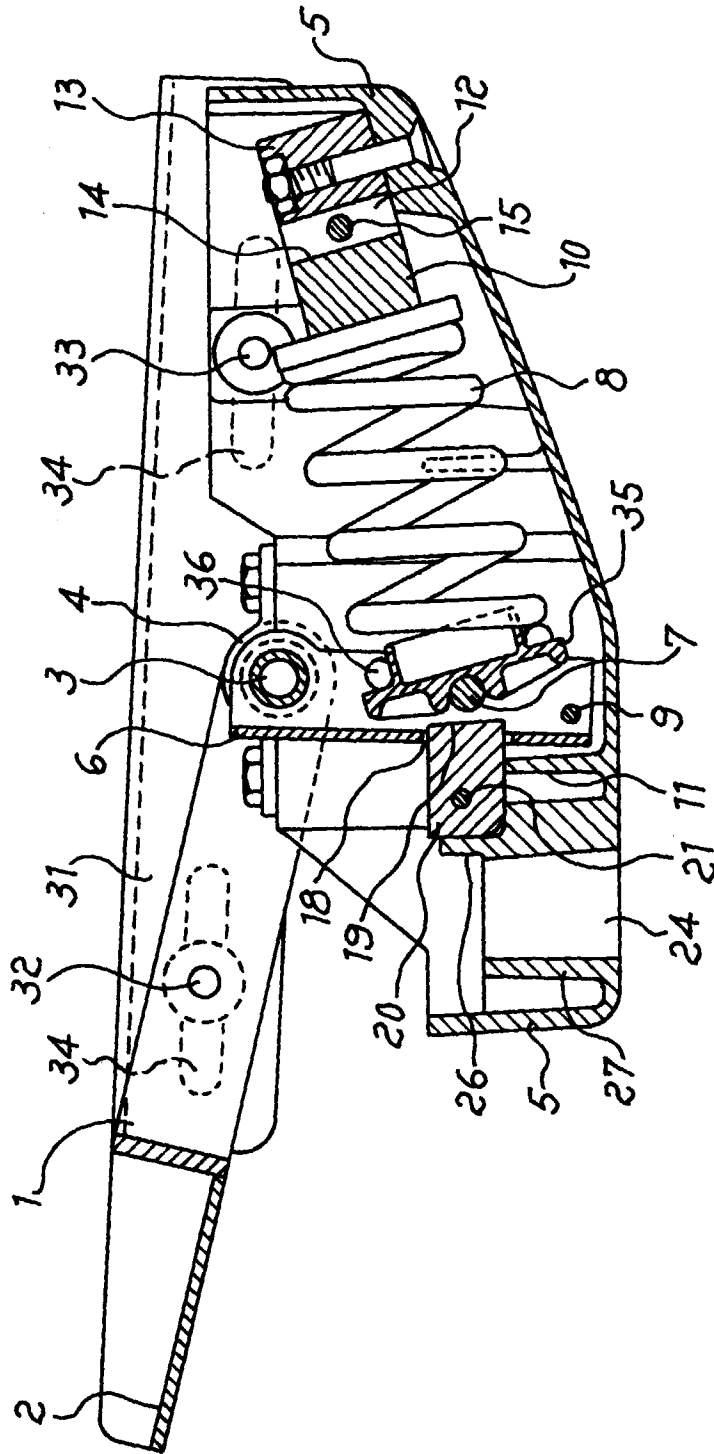

Fig. 2



**FIG. 3**

