

(No Model.)

2 Sheets—Sheet 1.

W. SAULMANN.  
FIBER DRYING APPARATUS.

No. 526,201.

Patented Sept. 18, 1894.

*Fig. 1.*

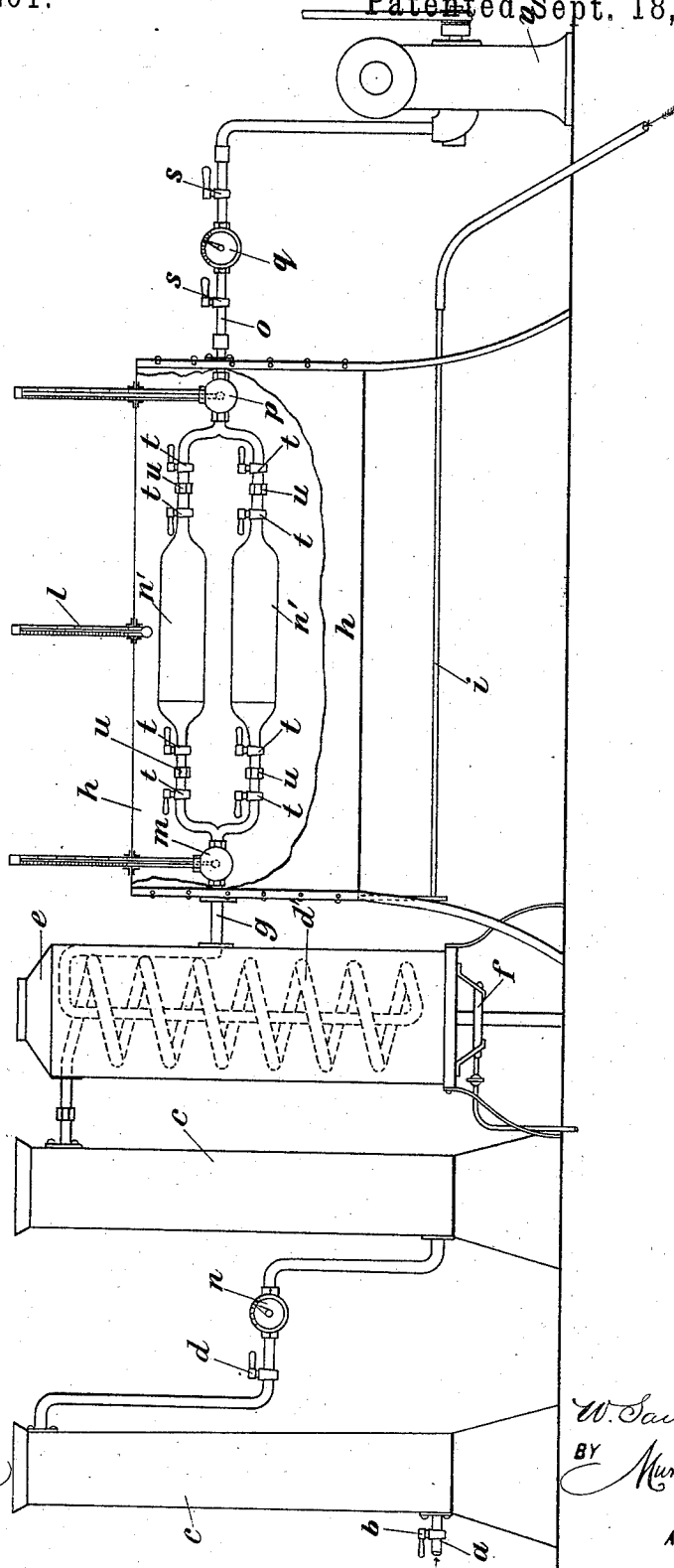

WITNESSES.  
*E. M. Clark*  
*C. Sedgwick*

INVENTOR:  
*W. Saulmann*  
 BY *Munn & Co.*  
 ATTORNEYS.

(No Model.)

2 Sheets—Sheet 2.

W. SAULMANN.  
FIBER DRYING APPARATUS.

No. 526,201.

Patented Sept. 18, 1894.

*Fig. 2.*

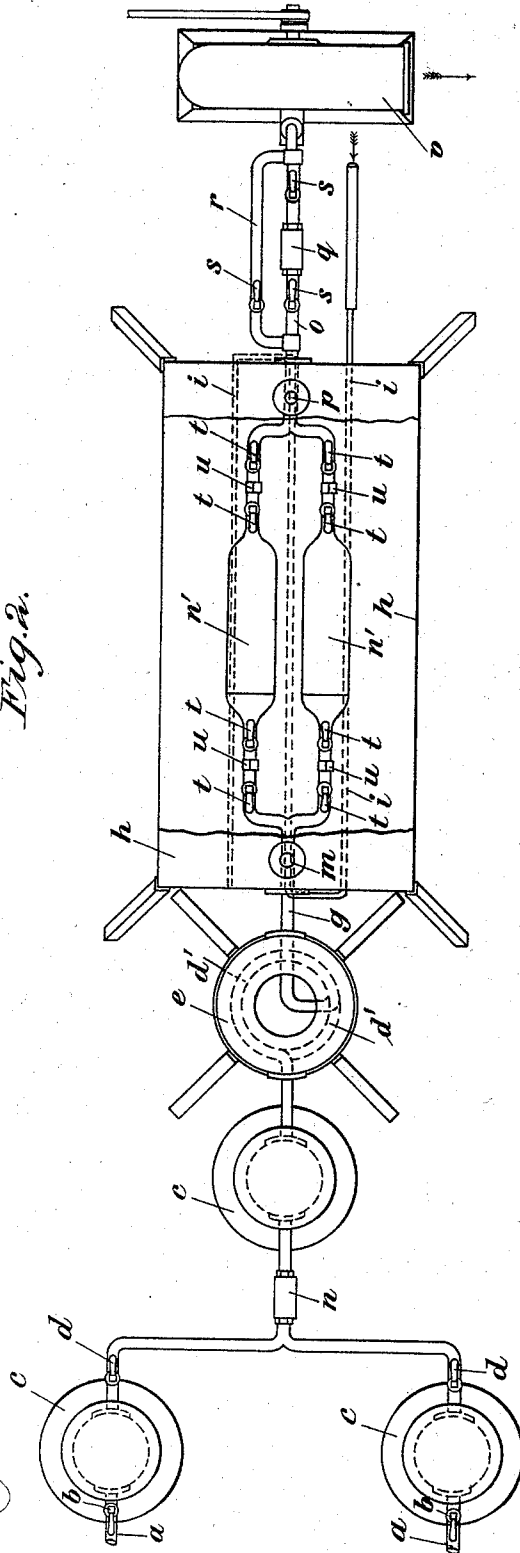

WITNESSES.  
*E. M. Clark*  
*C. Sedgwick*

INVENTOR:  
*W. Saulmann*  
BY  
*Munn & Co*  
ATTORNEYS.

# UNITED STATES PATENT OFFICE.

WILLY SAULMANN, OF BERLIN, GERMANY.

## FIBER-DRYING APPARATUS.

SPECIFICATION forming part of Letters Patent No. 526,201, dated September 18, 1894.

Application filed June 19, 1893. Serial No. 478,047. (No model.)

*To all whom it may concern:*

Be it known that I, WILLY SAULMANN, chemical student, of 26<sup>b</sup> Potsdamerstrasse, Berlin, in the Kingdom of Prussia and German Empire, have invented new and useful Fiber-Drying Apparatus, of which the following is a specification, reference being had therein to the accompanying drawings.

My invention relates to an apparatus for conditioning textile fibers said apparatus comprising means whereby a previously dried and heated current of air is conducted at an accelerated velocity through one or more receptacles, which inclose the textile fibers to be treated and are surrounded by hot air, in such a manner that the textile fibers to be treated come in direct and indirect contact with the hot air current. The weighing of the receptacles inclosing the fibers then takes place not during the conditioning itself but after the termination of the same and the cooling of the receptacles.

In carrying my invention into practice I employ the apparatus of which the accompanying drawings represent a side elevation in Figure 1 and a plan in Fig. 2.

It will be understood that the drawings are not designed to show the only constructional form imaginable, as various constituents of the apparatus may be replaced by equivalent parts without departing from the nature of my invention.

From one, two or more pipes *a*, which may be closed by cocks *b*, the air passes to a series of columns *c* which are filled with a hygroscopic material to dry the air current. Between these columns *c* is preferably included a cock *d* and a hygrometer *n* for enabling the proportion of moisture of the air passing through the same to be ascertained at any time.

The two columns *c* act as it were alternately, one being always included when the other is exhausted. The third column is only employed for the sake of safety.

From the last of the columns the air passes to a heating coil *d'* placed in a cylinder *e* and round which hot air from a source of heat *f* circulates, the said air being discharged at the open top of the cylinder *e*. The continuation *g* of the coil *d'* leads to a vessel *h* preferably made of a material which is a bad con-

ductor of heat, this vessel possessing also a gas burner *i* or equivalent source of heat whereby the temperature in its interior may be kept at the proper degree. A thermometer *l* dips into the said vessel and serves for controlling the temperature. After passing a thermometer *m* the aforesaid continuation of the coil *d'* leads to a number of receptacles *n'* of cylindrical or other appropriate shape (four being shown in the drawings) which contain the textile fibers to be dried. From these receptacles *n'* the pipe *o*, after passing a thermometer *p* leads to an exhaustor *v*, or to a suction fan, vacuum chamber or the like, whereby the air, the path of which has been described, is caused to acquire as great a velocity as possible. A hygrometer *q* is likewise included in the pipe *o*, but the latter has a loop-pipe *r* which owing to the arrangement of suitable cocks *s* will allow the air to reach the exhaustor without passing through the hygrometer. The admission to and discharge from the receptacles *n'* takes place through cocks *t* so that these receptacles and therefore their contents may be completely shut off from the passing hot air. The receptacles *n'* are so suspended that they may be removed from the apparatus in order to be weighed in the cold state. As shown in the accompanying drawings, the said receptacles are suspended by nuts *u*, but the suspension may of course also be effected by other appropriate means.

The process of conditioning with my improved apparatus is as follows: The weight of the receptacles *n'* is ascertained before introducing the textile material, the receptacles being dry and cold. Then the moist material is brought into the said receptacles, the cocks *t* are closed and the receptacles are weighed again. The weight of the moist material may then be determined by a simple subtraction. Thereupon the receptacles are placed in the vessel *h*, between the ends of the tubes connected to the pipes *g* and *o* respectively, and are firmly connected to the said tubes by means of the nuts *u* or their equivalents. The cocks *t* being opened, and the various parts of the apparatus set in proper operation, the current of dry heated air passes through the receptacles *n'* to dry the contents thereof. The air is normally

made to pass to the exhauster *v* through the loop-pipe *r*, but from time to time the cocks *s* are opened to allow the air to pass through the hygrometer *q*. When by comparing the latter with the hygrometer *n*, it is seen that the air has the same degree of moisture after leaving the receptacles *n'* as before entering the same, the drying operation is terminated. The cocks *t* are then closed, the heaters *f* and *i* extinguished, and the exhauster is stopped. After the receptacles have become cool, they are taken out and weighed again. As the weight of the receptacles is known, the weight of the dried material may be readily calculated. It will then be easy to determine the degree of humidity which was present in the fiber before its treatment, as the weight of the fiber has been ascertained both before and after the drying operation.

20 What I claim, and desire to secure by Letters Patent of the United States, is—

1. A fiber drying apparatus comprising a vessel and means for heating the same, a series of tubes terminating within the said vessel and adapted for connection with a supply of heated air, another series of tubes likewise terminating within the vessel and adapted for connection with a suction device, the ends of the second series of tubes being spaced from those of the first series, receptacles having tubular ends and adapted to fit between the ends of the corresponding tubes within the vessel, and means for detachably connecting the ends of the receptacles with the

corresponding tube ends, substantially as described. 35

2. A fiber drying apparatus comprising pipes for the admission of air, vessels connected with the said pipes and filled with a suitable material to absorb the moisture of the said air, a heating apparatus for heating the air, detachable receptacles constructed to receive the textile materials and connected with the air pipe, means for exteriorly heating said receptacles, and means for producing a continuous current of air through the said air pipes and receptacles, substantially as described. 40 45

3. A fiber drying apparatus comprising pipes for the admission of air, moisture-absorbing columns to which lead the said pipes, a heating coil connected with the said columns, a vessel and means for heating the inside of the same, receptacles constructed to receive the textile materials and detachably suspended within the said vessel, the said receptacles being connected with the said heating coil, and a fan for continuously drawing a current of air through the said pipes, moisture-absorbing columns, heating coil, and receptacles, substantially as described. 50 55 60

In witness whereof I have hereunto set my hand in presence of two witnesses.

WILLY SAULMANN.

Witnesses:

PAUL FISCHER,  
MAX GEUITK.