



Feb. 14, 1928.

1,659,042

H. H. MOTSCHMAN ET AL

ROLLING BED

Filed Aug. 17, 1925

2 Sheets-Sheet 2

Fig. 3.

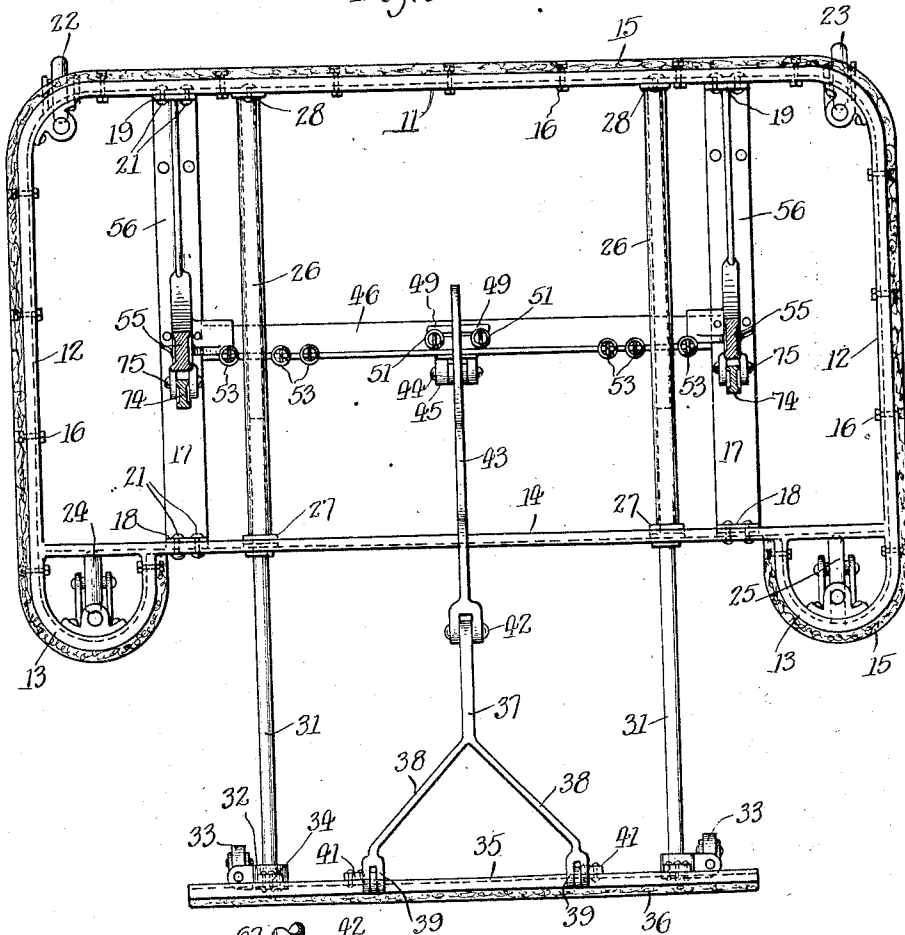
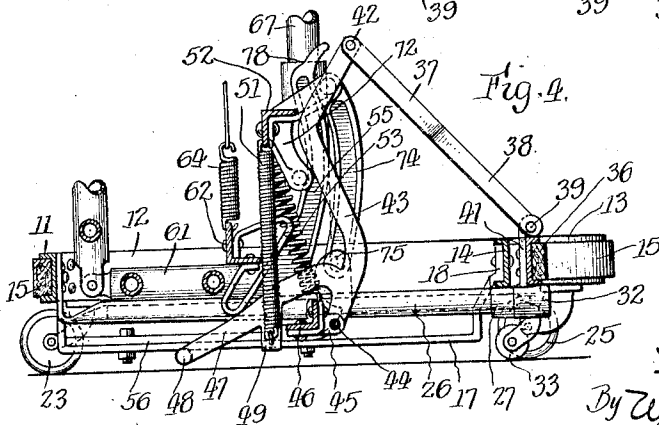

Fig. 4.



Inventors:  
Henry H. Motschman  
George E. Powers  
By Walter M. Fuller Atty.

# UNITED STATES PATENT OFFICE.

HENRY H. MOTSCHMAN AND GEORGE G. POWERS, OF CHICAGO, ILLINOIS, ASSIGNORS  
TO UNION BED AND SPRING COMPANY, OF CHICAGO, ILLINOIS, A CORPORATION  
OF ILLINOIS.

## ROLLING BED.

Application filed August 17, 1925. Serial No. 50,562.

Our invention pertains to movable beds and relates more particularly to those having roller or wheel-equipped bases adapted to be readily rolled to different positions, the bedstead itself being movably mounted on such base, whereby it may be shifted or rocked to operative or inoperative positions.

One of the main or principal features of the present invention resides in an automatically-actuated extension for such base or support whereby the latter is enlarged as the bedstead is lowered or swung down to horizontal position hence eliminating any danger of the base being inadequate in size to properly support the structure in all of its various positions and in fact the novel improvement permits the making of a folding or hinged bed of this type which occupies less floor space than usual when the bed proper is in upright position.

In order to enable those skilled in this art to fully understand this invention from structural and functional standpoints, in the accompanying drawings, forming a part of this specification, we have illustrated a desirable and preferred embodiment of the invention and for simplicity we have designated like parts with the same reference characters throughout the several views.

In these drawings:

Figure 1 is a fragmentary vertical section on line 1—1 of Figure 3, showing the bedstead in horizontal operative position and indicating the base as enlarged or extended;

Figure 2 is a fragmentary vertical section on line 2—2 of Figure 1;

Figure 3 is a horizontal section on line 3—3 of Figure 1; and

Figure 4 is a section similar to that of Figure 1 with the bedstead in upright position and with the base frame contracted.

Referring to these drawings, it will be seen that the new and improved structure comprises a main base frame of general rectangular form with rounded extensions at the two front corners.

This frame includes a channel bar having its flanges disposed outwardly and bent to provide a back section 11 (Figure 3) and two, parallel, end sections 12, 12, which at their front ends are curved at 13, 13 to form substantially semi-circular projections.

Another front channel bar 14 is joined or

connected to the ends 12, 12 and to the otherwise free ends of the curved parts 13, 13, all as is clearly presented in Figure 3.

The outer faces of the sections 11, 12 and 13 are supplied with a bent, resilient facing 15, such as felt or rubber, to prevent the marring of furnishings when the bed as a whole is moved around the room, bolts or screws or other convenient means 16 being employed to hold such cushioning means between the top and bottom marginal flanges of the bent bar.

Two connecting metal straps 17, 17 with upturned ends 18, 19 are fastened by such terminal parts to the inner faces of the front and rear bars 14 and 11 respectively by suitable rivets 21.

Such frame is mounted in any approved manner on four caster carrying-wheels 22, 23, 24 and 25 arranged at the four corners thereof.

A pair of spaced tubes 26, 26 are disposed below the front and rear bars of the frame and secured thereto by pocket-members 27, 27 surrounding the front ends of the two tubes and fastened to the under side of the front bar 14, the rear ends of the tubes being cut away and flattened to provide upstanding ears 28 by which they may be secured by rivets to the back bar 11.

These tubes telescopically accommodate within them a corresponding pair of extension rods 31, 31 adapted to be projected forwardly, such rods at their front ends being fitted with socket-pieces 32, 32 carrying smaller caster-wheels 33, 33 and supplied with upright lugs 34 riveted to the web of a channel cross-bar 35 equipped with a cushion facing 36 on its front face between its flanges.

A link 37, having a split or bifurcated front section 38, 38 is hinged at 39, 39 to members 41, 41 riveted to the inner face of the front cross-bar 35, its back end being hinged at 42 to the front end of a bent lever 43 of the form shown in Figures 1 and 4 fulcrumed at 44 on a bracket 45 mounted on an intermediate cross-bar 46 of angle cross-section.

Lever 43 has an angular extension 47 carrying an anti-friction roller 48 at its end, and such extension has lateral projections 49, 49 connected by a pair of coiled springs 51, 51 to the horizontal flange of an upper,

horizontal angle-bar 52 joined by a plurality of other coiled springs 53, 53 to the up-standing flange of the lower angle-bar 46, the ends of the latter being riveted at 54, 54 to lugs on a pair of castings 55, 55 of peculiar or specific shape having bases 56, 56 on and bolted to the tops of the straps 17, 17.

The bedstead or bed-frame proper comprises a head or foot piece 61 carrying a cross angle-bar 62 on which the usual metallic mattress-supporting fabric 63 is mounted through end helical springs 64, the element 61 and the angle-bar 62 having two brackets 65, 66 thereon connected to the corresponding members at the opposite end of the bedstead by the usual tubular side-rails 67 and also directly connected to the member 61 at 68, to the angle-bar 62 at 69 and to the shorter angle-bar 52 at 71.

Each of these castings 55 has an arm 72 hingedly mounted on the upper end of a link 74 rockingly supported at its lower end at 75 on the corresponding casting 55, each such member 65 or 66 having also a second arm 73 supplied with a transversely projecting lug 77 designed when the bedstead frame is in open or horizontal position to reside in a slight depression or pocket 78 in the upper portion of the correlated or complementary casting 55, as shown in Figure 1.

Angle-bar 62 at its middle carries a bent-bar cam or lever-actuator 79 in the same vertical plane as and adapted to operate the arm 47 through its terminal roller 48.

When the hinged or rockable bedstead is in upright or inactive position as depicted in Figure 4, the various elements occupy the relations shown and the base frame is fully contracted and occupies but relatively small floor space.

As the bedstead is swung down to active position, the several springs 53 become elongated and strained and act to counterweight the bedstead, at least in part.

During such descent of the bedstead or frame, the links 74 swing forwardly and ultimately the lugs 77 enter the shallow pockets or recesses 78, whereby that part of the bedstead shown in the drawings is effectively and efficiently supported, the portion of the bedstead not illustrated being supported by legs in the usual manner.

The upward travel of the angle-bar 52 is transmitted through the springs 51 to the lever 43 and the latter is rocked down automatically into horizontal position thereby projecting forwardly the auxiliary roller or carrying-wheel equipped frame or base section which prevents the main frame from tilting up or tipping over.

Thus as the bedstead is turned into operative position, its base frame is expanded or enlarged for the purpose indicated, as is illustrated in Figure 1.

When the bedstead is rocked upwardly, the lugs 77 leave their sockets and the supporting links 74 swing rearwardly.

The base frame, however, remains expanded or extended until the cam member or actuator 79 engages the roller 48, whereupon during the continued upward turning of the bedstead, the lever 43 is positively elevated progressively and the base frame is correspondingly contracted by the telescoping action hereinbefore referred to.

Hence the base expansion begins practically as soon as the downward rocking action of the bedstead is initiated and is completed well before the downward swinging is consummated.

On the other hand, however, the base remains fully broadened or enlarged until the bedstead has been swung up about one-half of its travel, its contraction or diminution of size gradually occurring during the remainder of the elevating movement of the bedstead.

From an understanding of this present preferred construction and its mode of operation, the manner of attaining the several advantageous objects will be quite apparent but it is to be remembered that the invention is not limited or restricted to the precise and exact details of construction since these may be modified within comparatively wide limits and still fall within the purview of the invention as defined by the appended claims.

We claim:

1. In a folding-bed structure, the combination of a main base-frame, a supplemental base-frame slidably mounted on said main base-frame and adapted to enlarge and contract the base-frame as a whole, a bed-frame rockingly mounted on said main-frame, a link connected to the front of said supplemental base-frame, a lever fulcrumed on said main base-frame and connected to said link, spring means connected to said lever and bed-frame, and cam means between said bed-frame and lever, whereby when the bed-frame is rocked down to horizontal position it tensions said spring means to project the supplemental base-frame fully forwardly during the initial downward movement of the bed-frame, said cam means retracting said supplemental base-frame during the latter portion only of the upward movement of the bed-frame.

2. In a folding-bed structure, the combination of a main base-frame, a supplemental base-frame slidably mounted on said main base-frame and adapted to enlarge and contract the base-frame as a whole, a bed-frame, links rockingly supporting said bed-frame on said main base-frame, recessed standards, projections on said bed-frame adapted to rest in said recesses when the bed-frame is down in horizontal operative position, a link con-

ned to the front of said supplemental base-frame, a lever fulcrumed on said main base-frame and connected to said link, spring means connected to said lever and bed-frame, and cam means between said bed-frame and lever, whereby when the bed-frame is rocked down to horizontal position it tensions said spring-means to project the supplemental base-frame fully forwardly during the initial downward movement of the bed-frame, said cam means retracting said supplemental base-frame during the latter portion only of the upward movement of said bed-frame.

In witness whereof we have hereunto set our hands.

HENRY H. MOTSCHMAN.  
GEORGE G. POWERS.