



(51) International Patent Classification:

A24D 1/20 (2020.01) A24F 40/42 (2020.01)

TN, TR, TT, TZ, UA, UG, US, UZ, VC, VN, WS, ZA, ZM, ZW.

(21) International Application Number:

PCT/EP2022/060586

(84) Designated States (unless otherwise indicated, for every kind of regional protection available):

ARIPO (BW, GH, GM, KE, LR, LS, MW, MZ, NA, RW, SD, SL, ST, SZ, TZ, UG, ZM, ZW), Eurasian (AM, AZ, BY, KG, KZ, RU, TJ, TM), European (AL, AT, BE, BG, CH, CY, CZ, DE, DK, EE, ES, FI, FR, GB, GR, HR, HU, IE, IS, IT, LT, LU, LV, MC, MK, MT, NL, NO, PL, PT, RO, RS, SE, SI, SK, SM, TR), OAPI (BF, BJ, CF, CG, CI, CM, GA, GN, GQ, GW, KM, ML, MR, NE, SN, TD, TG).

(22) International Filing Date:

21 April 2022 (21.04.2022)

(25) Filing Language:

English

(26) Publication Language:

English

(30) Priority Data:

21170093.5 23 April 2021 (23.04.2021) EP

Published:

— with international search report (Art. 21(3))

(71) Applicant: JT INTERNATIONAL SA [CH/CH]; 8 rue Kazem Radjavi, 1202 Geneva (CH).

(72) Inventors: MIYATANI, Yasuhiro; Viehmarktplatz 4, 54290 Trier (DE). SPIELES, Sandra; Am Bildstock 56, 54294 Trier (DE). KULKARNI, Pranav; Engelstrasse 98e, 54292 Trier (DE).

(74) Agent: SERJEANTS LLP; Dock, 75 Exploration Drive, Leicester Leicestershire LE4 5NU (GB).

(81) Designated States (unless otherwise indicated, for every kind of national protection available):

AE, AG, AL, AM, AO, AT, AU, AZ, BA, BB, BG, BH, BN, BR, BW, BY, BZ, CA, CH, CL, CN, CO, CR, CU, CZ, DE, DJ, DK, DM, DO, DZ, EC, EE, EG, ES, FI, GB, GD, GE, GH, GM, GT, HN, HR, HU, ID, IL, IN, IR, IS, IT, JM, JO, JP, KE, KG, KH, KN, KP, KR, KW, KZ, LA, LC, LK, LR, LS, LU, LY, MA, MD, ME, MG, MK, MN, MW, MX, MY, MZ, NA, NG, NI, NO, NZ, OM, PA, PE, PG, PH, PL, PT, QA, RO, RS, RU, RW, SA, SC, SD, SE, SG, SK, SL, ST, SV, SY, TH, TJ, TM,

(54) Title: AN AEROSOL GENERATING ARTICLE

(57) Abstract: An aerosol generating article (1, 2, 3, 4, 5) for use with an aerosol generating device (102) comprises a substantially planar aerosol generating substrate (14), at least one airflow channel (16) extending along the substantially planar aerosol generating substrate (14), and a wrapping member (22) surrounding the substantially planar aerosol generating substrate (14) and the at least one airflow channel (16).

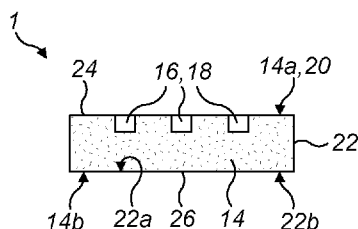

FIG. 2



## AN AEROSOL GENERATING ARTICLE

### Technical Field

The present disclosure relates generally to aerosol generating articles, and more particularly to an aerosol generating article for use with an aerosol generating device for heating the aerosol generating article to generate an aerosol for inhalation by a user. The present disclosure is particularly applicable to aerosol generating articles for use with a portable (hand-held) aerosol generating device.

### 10 Technical Background

The popularity and use of reduced-risk or modified-risk devices (also known as aerosol generating devices or vapour generating devices) has grown rapidly in recent years as an alternative to the use of traditional tobacco products. Various devices and systems are available that heat or warm aerosol generating substances to generate an aerosol for inhalation by a user.

A commonly available reduced-risk or modified-risk device is the heated substrate aerosol generating device, or so-called heat-not-burn device. Devices of this type generate an aerosol or vapour by heating an aerosol generating substrate to a temperature typically in the range 150°C to 300°C. Heating the aerosol generating substrate to a temperature within this range, without burning or combusting the aerosol generating substrate, generates a vapour which typically cools and condenses to form an aerosol for inhalation by a user of the device.

25 Currently available aerosol generating devices can use one of a number of different approaches to provide heat to the aerosol generating substrate, including resistive heating which makes use of a resistive heating element and induction heating which makes use of an induction coil and an inductively heatable susceptor.

30 Whichever approach is used to heat the aerosol generating substrate, the characteristics of the aerosol generated by the aerosol generating device are dependent upon a number of factors, including the construction of the aerosol generating article used with the

- 2 -

aerosol generating device. There is, therefore, a desire to provide an aerosol generating article which enables the characteristics of the aerosol generated during use of the article to be optimised, and which at the same time is easy to use in combination with an aerosol generating device.

5

### **Summary of the Disclosure**

According to a first aspect of the present disclosure, there is provided an aerosol generating article for use with an aerosol generating device, the aerosol generating article comprising:

- 10           a substantially planar aerosol generating substrate;  
              at least one airflow channel extending along the substantially planar aerosol generating substrate; and  
              a wrapping member surrounding the substantially planar aerosol generating substrate and the at least one airflow channel.

15

The aerosol generating article is for use with an aerosol generating device for heating the aerosol generating substrate, without burning the aerosol generating substrate, to volatise at least one component of the aerosol generating substrate and thereby generate a heated vapour which cools and condenses to form an aerosol for inhalation by a user  
20 of the aerosol generating device. The aerosol generating device is a hand-held, portable, device.

In general terms, a vapour is a substance in the gas phase at a temperature lower than its critical temperature, which means that the vapour can be condensed to a liquid by  
25 increasing its pressure without reducing the temperature, whereas an aerosol is a suspension of fine solid particles or liquid droplets, in air or another gas. It should, however, be noted that the terms 'aerosol' and 'vapour' may be used interchangeably in this specification, particularly with regard to the form of the inhalable medium that is generated for inhalation by a user.

30

By surrounding the at least one airflow channel with the wrapping member, vapour and/or aerosol generated during use of the aerosol generating article in an aerosol

- 3 -

generating device flows internally within the article, along the at least one airflow channel, before it is inhaled by a user. The formation of condensed matter on the internal surfaces of the aerosol generating device is thereby substantially eliminated, or at least minimised, and this may provide a number of benefits. For example, it may help  
5 to reduce residue build-up within the aerosol generating device, and reduce the number of cleaning and maintenance operations that a user of the device must perform. It may also help to ensure that the greatest possible quantity of vapour and/or aerosol is delivered to the user, and that the delivered vapour and/or aerosol has optimal characteristics.

10

The aerosol generating article may include a distal end, a mouth end and a longitudinal axis which may extend between the mouth end and the distal end. The mouth end is located at an opposite end of the aerosol generating article to the distal end. More particularly, the mouth end is located downstream of the distal end with respect to an  
15 airflow direction through the aerosol generating article, e.g., during use of the aerosol generating article in an aerosol generating device. The at least one airflow channel may extend in a first direction which may be substantially parallel to the longitudinal axis. Air flows along the at least one airflow channel, from the distal end to the mouth end, during use of the aerosol generating article thereby ensuring that a maximum amount  
20 of volatile components are released into the air from the heated aerosol generating substrate as the air flows along the airflow channel. This in turn ensures that the greatest possible quantity of vapour and/or aerosol is generated and delivered to the user during use of the aerosol generating article.

25 The at least one airflow channel may comprise at least one groove. The at least one groove may be formed in a surface of the substantially planar aerosol generating substrate. The at least one groove can be easily formed during manufacture of the aerosol generating article, for example by pressing a surface of the substantially planar aerosol generating substrate.

30

The aerosol generating substrate may include a plurality of said grooves. The grooves may be arranged side by side, for example to form a fluted surface. By providing a

- 4 -

plurality of grooves, an increased quantity of vapour and/or aerosol may be generated and delivered to the user during use of the aerosol generating article in an aerosol generating device.

- 5 The at least one airflow channel may comprise at least one airflow passage formed internally within the aerosol generating substrate. The airflow passage can be easily formed during manufacture of the aerosol generating article. Also, because the airflow passage is fully surrounded by the aerosol generating substrate, a maximum amount of volatile components can be released into the air from the heated aerosol generating
- 10 substrate as the air flows along the airflow passage, thus ensuring that the greatest possible quantity of vapour and/or aerosol is generated and delivered to the user during use of the aerosol generating article in an aerosol generating device.

In one example, a single airflow passage may be formed internally within the aerosol

15 generating substrate, for example in a substantially central position within the cross-section of the aerosol generating substrate. In another example, a plurality of airflow passages may be formed internally within the aerosol generating substrate, and the airflow passages may be arranged side by side, e.g., in a second direction perpendicular to the first direction (longitudinal direction). By providing a plurality of airflow

20 passages, an increased quantity of vapour and/or aerosol may be generated and delivered to the user during use of the aerosol generating article in an aerosol generating device.

The aerosol generating substrate may comprise a plurality of aerosol generating strips.

25 The aerosol generating strips may extend in a first direction, e.g., substantially parallel to the longitudinal axis, and may be arranged intermittently in a second direction which may be substantially perpendicular to the first direction. The aerosol generating article may comprise a plurality of said airflow channels and one of said airflow channels may be formed between each pair of intermittently arranged aerosol generating strips. Each

30 airflow channel is in fluid communication with the pair of intermittently arranged aerosol generating strips that form the particular airflow channel. Vapour or aerosol generating during heating of the aerosol generating strips thus flows into the adjacent

- 5 -

airflow channel(s), ensuring that the generated vapour or aerosol can be entrained in air flowing through the airflow channel(s) and delivered to a user during inhalation when the aerosol generating article is heated during use in an aerosol generating device. The aerosol generating strips have at least one side surface extending in the first direction  
5 directly exposed to, and in fluid communication with, an adjacent airflow channel. Thanks to this arrangement, a large surface area of each aerosol generating strip is directly exposed to at least one adjacent airflow channel, allowing increased vapour or aerosol delivery through the airflow channels for inhalation by a user. Additionally with this arrangement, the airflow channels can be easily formed during manufacture of the  
10 aerosol generating article, for example by spacing apart the aerosol generating strips in the second direction to form the airflow channels. The aerosol generating article can, therefore, be manufactured efficiently and mass produced with relative ease.

The aerosol generating strips may all comprise the same aerosol generating material.  
15 Alternatively, at least some of the aerosol generating strips may comprise aerosol generating materials that differ from each other. For example, at least one of the aerosol generating strips may comprise a first aerosol generating material and at least another of the aerosol generating strips may comprise a second aerosol generating material that differs from the first aerosol generating material. One or more of the aerosol generating  
20 strips could include a flavourant. An aerosol with improved characteristics and/or user appeal may, thus, be generated during use of the aerosol generating article in an aerosol generating device. The use of aerosol generating strips provides the further advantage that different regions of the aerosol generating substrate may be heated differently to generate a desired aerosol during use of the aerosol generating article in an aerosol  
25 generating device, for example by heating different aerosol generating strips to different temperatures and/or at different heating rates. This is particularly advantageous in embodiments in which the aerosol generating strips comprise materials which differ from each other and/or in which one or more (but not all) of the aerosol generating strips include a flavourant, because vapour or aerosol having different characteristics  
30 (e.g., different temperatures, densities, compositions, active ingredients, flavours, etc.) may be released into different airflow channels. When these vapours or aerosols are mixed, e.g., in the portion of the aerosol generating article downstream of the aerosol

- 6 -

generating substrate that is formed by the aerosol generating strips, the resultant vapour or aerosol may have improved characteristics and may result in the generation of an aerosol with improved user appeal.

5 The substantially planar aerosol generating substrate may have a flat rectangular shape which may have a pair of main surfaces. The wrapping member may comprise a pair of rectangular sheets which may be attached, respectively, to the pair of main surfaces. The aerosol generating article may have a pleasing aesthetic appearance due to the flat rectangular shape of the aerosol generating substrate. The aerosol generating substrate  
10 may be readily covered by the wrapping member, thereby ensuring that a user does not directly touch the aerosol generating substrate during handling of the aerosol generating article. The flat rectangular shape may also facilitate packaging and storage of multiple aerosol generating articles.

15 In embodiments in which the aerosol generating substrate comprises a plurality of aerosol generating strips, upper and lower surfaces of the aerosol generating strips may define the main surfaces of the aerosol generating substrate. The wrapping member contacts, and may be attached to (e.g., by a pharmaceutically acceptable adhesive), the upper and lower surfaces of the aerosol generating strips. Thus, the aerosol generating  
20 strips are secured to the wrapping member and are thereby secured in position relative to each other to define the airflow channels between the intermittently arranged (i.e., spaced) aerosol generating strips.

The aerosol generating article may comprise a support member which may form a  
25 mouth-end portion of the article. The support member may have a tubular form, e.g., a rectangular tubular form, to receive a downstream end of the aerosol generating substrate and the at least one airflow channel. The support member may be self-supporting and may, for example, comprise cardboard or a plastics material. The support member may advantageously deliver vapour and/or aerosol generated during  
30 use of the article directly to a user's mouth. The support member may allow heated vapour generated during use of the aerosol generating article to cool and condense to form an aerosol with optimal characteristics for inhalation by a user.

- 7 -

5 The wrapping member may comprise a material which is substantially non-electrically conductive and non-magnetically permeable and may, for example, comprise a paper wrapper. The use of a paper wrapper may facilitate manufacture and handing of the aerosol generating article and may enhance aerosol generation.

10 The wrapping member may have a porous inner surface which may face towards the aerosol generating substrate for absorbing condensation. The porous inner surface may further help to ensure that the formation of condensed matter on the internal surfaces of the aerosol generating device is substantially eliminated, or at least minimised. The wrapping member may have an anti-stick outer surface which may face away from the aerosol generating substrate. For example, the wrapping member may comprise an anti-stick coating on the outer surface. The anti-stick outer surface may help to ensure that the wrapping member does not stick to surfaces of the aerosol generating device when it has been heated. Together, the porous inner surface and the anti-stick outer surface may help to reduce residue build-up within the aerosol generating device, thus reducing the number of cleaning and maintenance operations that a user of the device may have to perform.

20 The aerosol generating substrate may comprise a non-liquid aerosol generating material, for example any type of solid or semi-solid material. Example types of aerosol generating solids include powder, granules, pellets, shreds, strands, particles, gel, strips, loose leaves, cut leaves, cut filler, porous material, foam material or sheets. The aerosol generating substrate may comprise plant derived material and in particular, may comprise a tobacco. It may advantageously comprise reconstituted tobacco, for example including tobacco and any one or more of cellulose fibres, tobacco stalk fibres and inorganic fillers such as CaCO<sub>3</sub>.

30 Consequently, the aerosol generating device with which the aerosol generating articles are intended for use may be referred to as a “heated tobacco device”, a “heat-not-burn tobacco device”, a “device for vaporising tobacco products”, and the like, with this being interpreted as a device suitable for achieving these effects. The features disclosed

- 8 -

herein are equally applicable to devices which are designed to vaporise any aerosol generating substrate.

The aerosol generating substrate may comprise an aerosol-former. Examples of aerosol-  
5 formers include polyhydric alcohols and mixtures thereof such as glycerine or propylene glycol. Typically, the aerosol generating substrate may comprise an aerosol-former content of between approximately 5% and approximately 50% on a dry weight basis. In some embodiments, the aerosol generating substrate may comprise an aerosol-former content of between approximately 10% and approximately 20% on a dry weight  
10 basis, and possibly approximately 15% on a dry weight basis.

The aerosol generating article may be configured for use with an electrically-operated aerosol generating device including a heater. The heater may be a resistive heater or may be an inductive heater. Upon heating, the aerosol generating substrate may release  
15 volatile compounds. The volatile compounds may include nicotine or flavour compounds such as tobacco flavouring.

#### **Brief Description of the Drawings**

Figure 1 is a diagrammatic longitudinal cross-sectional view of a first example of an  
20 aerosol generating article;

Figure 2 is a diagrammatic cross-sectional view along the line A-A in Figure 1;

Figure 3 is a diagrammatic cross-sectional view similar to Figure 2 of a second example of an aerosol generating article;

Figure 4 is a diagrammatic longitudinal cross-sectional view of a third example of an  
25 aerosol generating article;

Figure 5 is a diagrammatic longitudinal cross-sectional view of a fourth example of an aerosol generating article;

Figure 6 is a diagrammatic cross-sectional view along the line B-B in Figure 5;

Figure 7 is a diagrammatic longitudinal cross-sectional view of a fifth example of an  
30 aerosol generating article;

Figure 8 is a diagrammatic cross-sectional view along the line C-C in Figure 7; and

- 9 -

Figure 9 is a diagrammatic cross-sectional view of an aerosol generating system comprising an aerosol generating device and an aerosol generating article according to the present disclosure.

## 5 Detailed Description of Embodiments

Embodiments of the present disclosure will now be described by way of example only and with reference to the accompanying drawings.

Referring initially to Figures 1 and 2, there is shown a first example of an aerosol generating article 1 for use with an electrically-operated aerosol generating device 102, an example of which will be described later in this specification with reference to Figure 9. The aerosol generating article 1 is substantially planar and has a distal end 10 and a mouth end 12 (or proximal end) at the opposite end of the aerosol generating article 1. The mouth end 12 is downstream of the distal end 10 with respect to an airflow direction through the aerosol generating article 1 as represented in Figure 1 by the three arrows. A longitudinal axis extends between the distal end 10 and the mouth end 12 to define a longitudinal direction of the aerosol generating article 1.

The aerosol generating article 1 comprises a substantially planar aerosol generating substrate 14. The aerosol generating substrate 14 comprises a bulk or mass of aerosol generating material and has a flat rectangular shape with a pair of oppositely disposed main surfaces 14a, 14b. The aerosol generating article 1 is a consumable, or disposable, article in which the aerosol generating substrate 14 may comprise tobacco or a tobacco material.

The aerosol generating article 1 comprises a plurality of airflow channels 16 which, in the illustrated example, comprise a plurality of grooves 18 formed in a main surface 14a of the aerosol generating substrate 14. The grooves 18 are arranged side-by-side and parallel to each other, and the grooves 18 extend in the longitudinal direction between the distal end 10 and the mouth end 12, substantially parallel to the longitudinal axis. Together, the grooves 18 form a fluted surface 20. The grooves 18 may be formed in any suitable manner, for example by pressing the main surface 14a of the aerosol

- 10 -

generating substrate 14 with a suitably shaped pressing tool. Three grooves 18 are shown in the example of Figures 1 and 2, but it will be understood that any suitable number of grooves 18 can be provided, for example depending on the desired resistance-to-draw of the aerosol generating article 1. It should also be noted that the  
5 grooves 18 may have any suitable cross-sectional shape including, but not limited to, square as illustrated in Figure 2, rectangular, trapezoidal, or semi-circular.

The aerosol generating article 1 further comprises a wrapping member 22 which surrounds the aerosol generating substrate 14 and the grooves 18. The aerosol  
10 generating substrate 14 and the grooves 18 are, thus, fully enclosed by the wrapping member 22 which may, for example, comprise cigarette paper or a similar material. The wrapping member 22 comprises a pair of rectangular sheets 24, 26 which are attached, respectively, to the main surfaces 14a, 14b of the aerosol generating substrate 14. The rectangular sheets 24, 26 are typically formed by a single sheet of material which is  
15 wrapped around the aerosol generating substrate 14 and which may have overlapping edges that are adhered to each other to secure the wrapping member 22 in position around the aerosol generating substrate 14 and the grooves 18.

In an exemplary and non-limiting example, the aerosol generating substrate 14 may  
20 have a length (in the longitudinal direction of the aerosol generating article 1) of approximately 18.0 mm, may have a width of approximately 11.8 mm, and may have a thickness (or depth) of approximately 1.2 mm. The aerosol generating substrate 14 may be spaced inwardly from the distal end 10 of the aerosol generating article 1 by a small distance, for example approximately 3.0 mm, as shown in Figure 1. The aerosol  
25 generating article 1 may have a width of approximately 12.0 mm and a thickness (or depth) of approximately 1.4 mm to accommodate the aerosol generating substrate 14 inside the wrapping member 22. The aerosol generating article 1 may have any suitable length between the distal end 10 and the mouth end 12 by varying the length of the portion of the wrapping member 22 that extends between the downstream end of the  
30 aerosol generating substrate 14 and the mouth end 12. As vapour flows through this portion of the wrapping member 22 during use of the aerosol generating article 1 in an aerosol generating device 102, the vapour may cool and condense to form an aerosol

- 11 -

for inhalation by a user. Thus, the length of the portion of the wrapping member 22 that extends between the downstream end of the aerosol generating substrate 14 and the mouth end 12 of the aerosol generating article 1 may be selected at the time of manufacture to provide an aerosol with desired characteristics.

5

In some embodiments, the wrapping member 22 comprises a porous inner surface 22a which faces towards the aerosol generating substrate 14 and which is capable of absorbing condensation that may be formed during the heating process. Alternatively or in addition, the wrapping member 22 can comprise an anti-stick outer surface 22b  
10 facing away from the aerosol generating substrate 14 to reduce the risk of the wrapping member 22 sticking to surfaces of the aerosol generating device 102 when it has been heated. The anti-stick outer surface 22b may comprise an anti-stick coating on the outer surface 22b of the wrapping member 22.

15 Referring now to Figure 3, there is shown a second example of an aerosol generating article 2. The aerosol generating article 2 is similar to the aerosol generating article 1 described above with reference to Figures 1 and 2 and corresponding features are identified using the same reference numerals.

20 The aerosol generating article 2 includes a plurality of airflow channels 16 in the form of airflow passages 30 formed internally within the aerosol generating substrate 14. Like the grooves 18, the airflow passages 30 extend in the longitudinal direction, between the distal end 10 and the mouth end 12, substantially parallel to the longitudinal axis. The airflow passages 30 are arranged side-by-side roughly at a mid-point between  
25 the main surfaces 14a, 14b of the aerosol generating substrate 14, although different positions could be adopted provided that each airflow passage 30 is fully surrounded by the aerosol generating material that forms the aerosol generating substrate 14. It should also be noted that the airflow passages 30 may have a variety of cross-sectional shapes including, but not limited to, square as illustrated in Figure 3, rectangular,  
30 circular, oval, or triangular.

- 12 -

Referring now to Figure 4, there is shown a third example of an aerosol generating article 3. The aerosol generating article 3 is similar to the aerosol generating article 1 described above with reference to Figures 1 and 2 and corresponding features are identified using the same reference numerals.

5

The aerosol generating article 3 includes a support member 28 positioned at the mouth end 12 of the aerosol generating article 3 to form a mouth-end portion 34 which can be engaged by a user's lips during use of the aerosol generating article 3 in an aerosol generating device 102. The support member 28 typically comprises a self-supporting material such as cardboard or a plastics material and has a rectangular tubular form when viewed in cross-section to receive a downstream end of the aerosol generating substrate 14 and the grooves 18 formed in the surface 14a. The wrapping member 22 also surrounds the support member 28.

15 Referring now to Figures 5 and 6, there is shown a fourth example of an aerosol generating article 4. The aerosol generating article 4 is similar to the aerosol generating article 2 described above with reference to Figure 3 and corresponding features are identified using the same reference numerals.

20 The aerosol generating article 4 includes an airflow channel 16 in the form of a single airflow passage 30 formed internally within the aerosol generating substrate 14. The airflow passage 30 extends in the longitudinal direction, between the distal end 10 and the mouth end 12, substantially parallel to the longitudinal axis. The airflow passage 30 is positioned centrally within the aerosol generating substrate 14 and is surrounded on all sides by the aerosol generating substrate 14, ensuring that volatile components can be released from the aerosol generating substrate 14 and entrained in air flowing through the airflow passage 30 during use of the aerosol generating article 4 in an aerosol generating device 102.

30 The aerosol generating article 4 is shown without a support member 28 at the mouth end 12. A support member 28 can, however, be provided at the mouth end 12 of the

- 13 -

aerosol generating article 4 as explained above in connection with the aerosol generating article 3 of Figure 4.

Referring now to Figures 7 and 8, there is shown a fifth example of an aerosol generating article 5. The aerosol generating article 5 is similar to the aerosol generating articles 1, 2, 3, 4 described above with reference to Figures 1 to 6 and corresponding features are identified using the same reference numerals.

In the aerosol generating article 5, the aerosol generating substrate 14 comprises a plurality of aerosol generating strips 32 which extend in a first direction, substantially parallel to the longitudinal direction of the aerosol generating article 5, between the distal end 10 and the mouth end 12. The aerosol generating strips 32 are spaced apart laterally, in other words they are arranged intermittently and spaced apart in a second direction perpendicular to the first direction. This intermittent arrangement (or spacing) of the aerosol generating strips 32 forms airflow channels 16, with an airflow channel 16 being formed between each adjacent pair of aerosol generating strips 32. Each airflow channel 16 is directly exposed to, and in fluid communication with, the adjacent aerosol generating strips 32 that form the airflow channel 16, which means that vapour or aerosol generated during use of the aerosol generating article 5 can flow into the airflow channels 16 to be entrained in an airflow through the airflow channels 16 and delivered to a user during inhalation, when the aerosol generating article 5 is used in an aerosol generating device 102 as described below.

Each of the aerosol generating strips 32 has an in use upper and lower surface, and the upper and lower surfaces 32 of the aerosol generating strips 32 together define the respective main surfaces 14a, 14b of the aerosol generating substrate 14. The wrapping member 22 can be attached to the upper and lower surfaces of the aerosol generating strips 32, for example by a pharmaceutically acceptable adhesive. In this way, the aerosol generating strips 32 are secured to the wrapping member 22 and are secured in position relative to each other to define the airflow channels 16 between the intermittently arranged (i.e., spaced) aerosol generating strips 32.

- 14 -

In the illustrated example, the aerosol generating strips 32 all comprise the same aerosol generating material. However, in other examples, at least some of the aerosol generating strips 32 may comprise aerosol generating materials that differ from each other. For example, at least one of the aerosol generating strips 32 may comprise a first aerosol  
5 generating material and at least another one of the aerosol generating strips 32 may comprise a second aerosol generating material that differs from the first aerosol generating material. In both examples, at least one of the aerosol generating strips 32 may include a flavourant. By providing aerosol generating strips 32 that comprise different aerosol generating materials and/or aerosol generating strips 32 that include a  
10 flavourant, an aerosol with improved user appeal may be generated during use of the aerosol generating article 5.

The aerosol generating article 5 is shown without a support member 28 at the mouth end 12. A support member 28 can, however, be provided at the mouth end 12 of the  
15 aerosol generating article 5 as explained above in connection with the aerosol generating article 3 of Figure 4.

Referring now to Figure 9, there is shown an aerosol generating system 100 comprising an aerosol generating device 102 and a first example of an aerosol generating article 1  
20 as described above with reference to Figures 1 and 2. It will be appreciated that the aerosol generating device 102 could be used in combination with an alternative aerosol generating article according to the present disclosure, such as the second, third, fourth or fifth examples of the aerosol generating articles 2, 3, 4, 5 described above with reference to Figures 3 to 8.

25

The aerosol generating device 102 comprises a receiving chamber 106 and a heater 104 positioned in the device body 108 to provide heat to the receiving chamber 106. The heater 104 may be a resistive heater or may alternatively be an induction heater comprising a susceptor and an electromagnetic field generator including an induction  
30 coil.

- 15 -

In use, a user inserts the aerosol generating article 1 into the receiving chamber 106. The aerosol generating device 102 may include a cover 110 and a pivotal mounting 112 that allows the cover 110 to be moved between a closed position shown in Figure 9 and an open position (not shown). As will be understood by one of ordinary skill in the art,  
5 a user must pivot the cover 110 to the open position to permit insertion of the aerosol generating article 1 into the receiving chamber 106 and then pivot the cover back to the closed position shown in Figure 9 to retain the aerosol generating article 1 in position in the receiving chamber 106.

10 The aerosol generating device 102 includes a power source 114, e.g., a rechargeable battery, and a controller 116, both of which are connected to the heater 104. The heater 104 may be actuated manually, e.g., via a user interface such as a button on the aerosol generating device 102, or may be actuated automatically in response to a user drawing on a mouthpiece 118 of the aerosol generating device 102. The aerosol generating  
15 device 102 includes one or more air inlets 120 to allow air to flow into the aerosol generating article 1 and through the grooves 18 formed in the surface of the aerosol generating substrate 14. The airflow direction is illustrated by the arrows in Figure 9.

With the aerosol generating article 1 positioned in the receiving chamber 106, power is  
20 supplied from the power source 114 to the heater 104 (either by a manual or automatic actuation of the heater 104 as described above), thereby heating the aerosol generating substrate 14 without burning it to release one or more volatile components. The volatile components are entrained in the air flowing through the grooves 18 thereby forming a vapour. The vapour cools and condenses as it flows through the grooves 18 to form an  
25 aerosol which is inhaled by a user through the mouthpiece 118 of the aerosol generating device 102.

When the aerosol generating substrate 14 becomes depleted and no longer releases sufficient volatile components to generate an aerosol with acceptable qualities, the  
30 aerosol generating article 1 can be removed from the receiving chamber 106 after pivoting the cover 110 to the open position, and a replacement aerosol generating article 1 can be inserted in its place.

- 16 -

In the event that the aerosol generating device 102 is used in combination with an aerosol generating article having a support member 28, for example the third example of the aerosol generating article 3 described above with reference to Figure 4, the support member 28 may project from an open end 106a of the receiving chamber 106 thereby enabling a user's lips to engage the mouth-end portion 34 of the aerosol generating article 3 formed by the support member 28.

Although exemplary embodiments have been described in the preceding paragraphs, it should be understood that various modifications may be made to those embodiments without departing from the scope of the appended claims. Thus, the breadth and scope of the claims should not be limited to the above-described exemplary embodiments.

Any combination of the above-described features in all possible variations thereof is encompassed by the present disclosure unless otherwise indicated herein or otherwise clearly contradicted by context.

Unless the context clearly requires otherwise, throughout the description and the claims, the words "comprise", "comprising", and the like, are to be construed in an inclusive as opposed to an exclusive or exhaustive sense; that is to say, in the sense of "including, but not limited to".

**Claims**

1. An aerosol generating article (1, 2, 3, 4, 5) for use with an aerosol generating device (102), the aerosol generating article comprising:
  - a substantially planar aerosol generating substrate (14);
  - 5 at least one airflow channel (16) extending along the substantially planar aerosol generating substrate (14); and
  - a wrapping member (22) surrounding the substantially planar aerosol generating substrate (14) and the at least one airflow channel (16).
- 10 2. An aerosol generating article according to claim 1, wherein the aerosol generating article includes a distal end (10), a mouth end (12), a longitudinal axis extending between the mouth end (12) and the distal end (10), and the at least one airflow channel (16) extends in a first direction substantially parallel to the longitudinal axis.
- 15 3. An aerosol generating article according to claim 1 or claim 2, wherein the at least one airflow channel (16) comprises at least one groove (18) formed in a surface (14a) of the substantially planar aerosol generating substrate (14).
- 20 4. An aerosol generating article according to claim 3, wherein the aerosol generating substrate (14) includes a plurality of said grooves (18) arranged side by side to form a fluted surface (20).
5. An aerosol generating article according to claim 1 or claim 2, wherein the at  
25 least one airflow channel (16) comprises at least one airflow passage (30) formed internally within the aerosol generating substrate (14).
6. An aerosol generating article according to any preceding claim, wherein:
  - the aerosol generating substrate (14) comprises a plurality of aerosol generating  
30 strips (32) extending in a first direction and arranged intermittently in a second direction perpendicular to the first direction;

- 18 -

the aerosol generating article comprises a plurality of said airflow channels (16) and one of said airflow channels (16) is formed between each pair of intermittently arranged aerosol generating strips (32) and in fluid communication with said pair of intermittently arranged aerosol generating strips (32).

5

7. An aerosol generating article according to claim 6, wherein the aerosol generating strips (32) all comprise a same aerosol generating material.

8. An aerosol generating article according to claim 6, wherein at least one of the aerosol generating strips (32) comprises a first aerosol generating material and at least one of the aerosol generating strips (32) comprises a second aerosol generating material that differs from the first aerosol generating material.

9. An aerosol generating article according to any of claims 6 to 8, wherein at least one of the aerosol generating strips (32) includes a flavourant.

10. An aerosol generating article according to any preceding claim, wherein the substantially planar aerosol generating substrate (14) has a flat rectangular shape having a pair of main surfaces (14a, 14b) and the wrapping member (22) comprises a pair of rectangular sheets (24, 26) attached, respectively, to the pair of main surfaces (14a, 14b).

11. An aerosol generating article according to any preceding claim, wherein the aerosol generating article comprises a support member (28) forming a mouth-end portion (34) of the article, and the support member (28) has a tubular form to receive a downstream end of the aerosol generating substrate (14) and the at least one airflow channel (16).

12. An aerosol generating article according to any preceding claim, wherein the wrapping member (22) has a porous inner surface (22a) facing towards the aerosol generating substrate (14) for absorbing condensation and an anti-stick outer surface (22b) facing away from the aerosol generating substrate (14).

- 19 -

13. An aerosol generating article according to claim 12, wherein the wrapping member (22) comprises an anti-stick coating on the outer surface (22b).

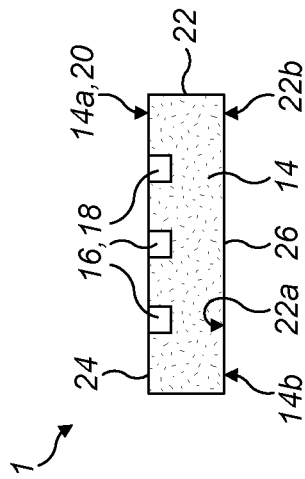
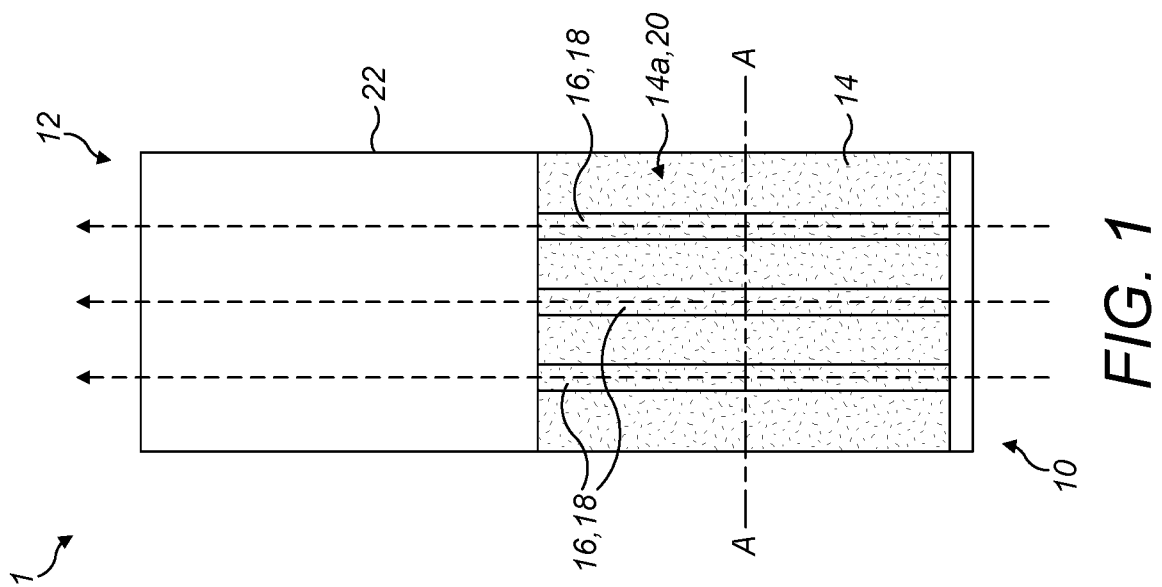

FIG. 2

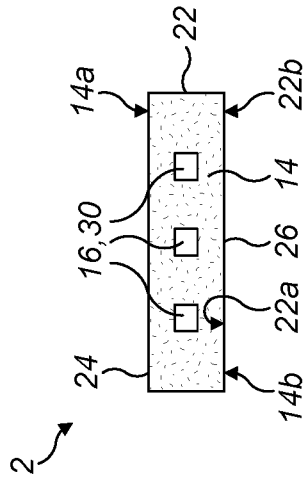

FIG. 3

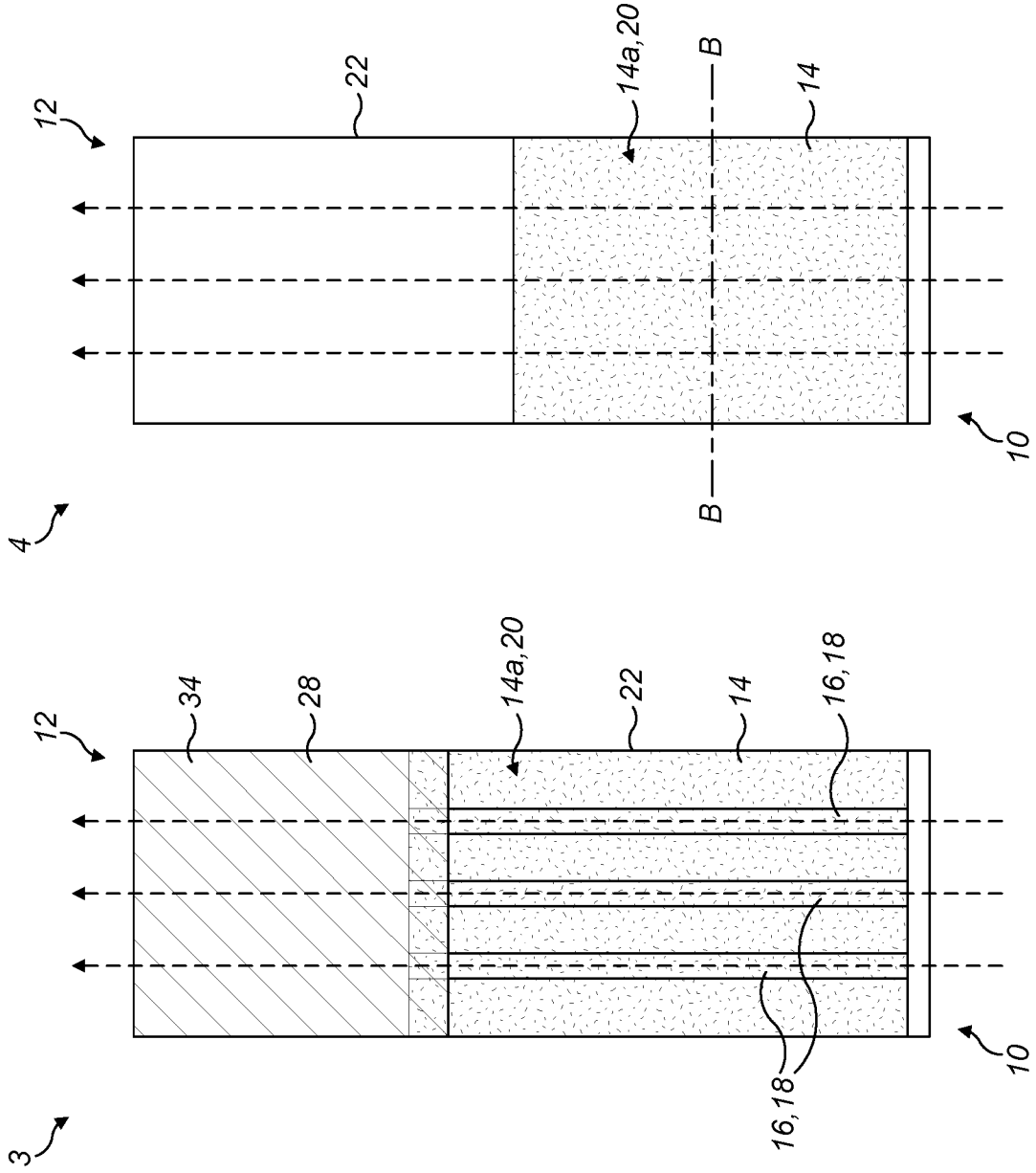

FIG. 5

FIG. 4

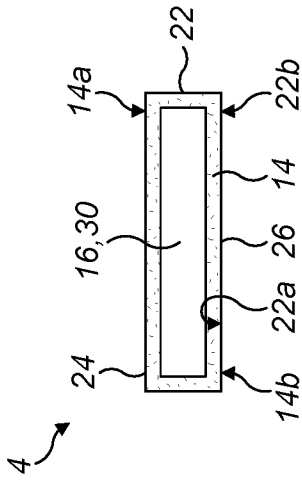

FIG. 6

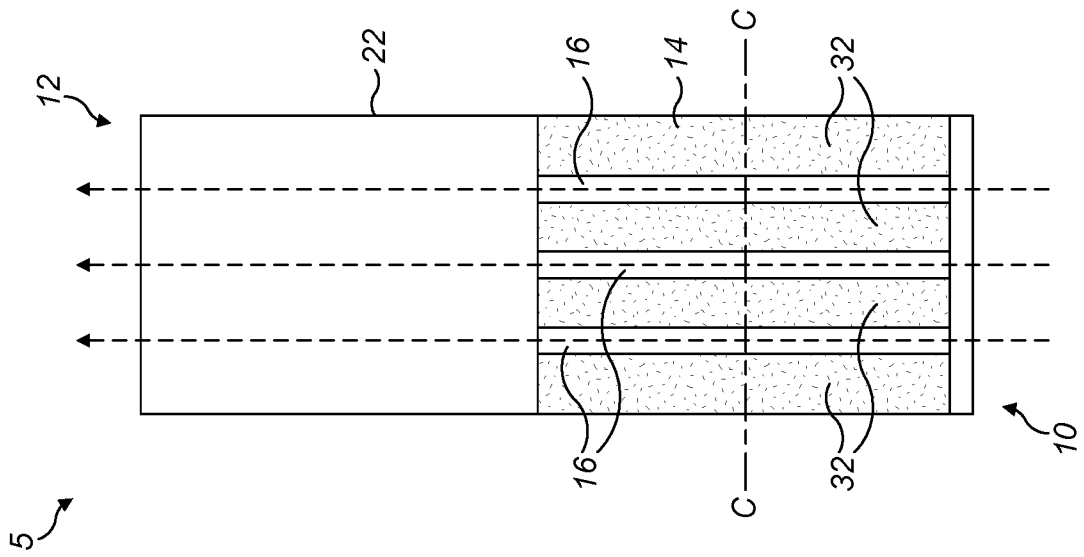

FIG. 7

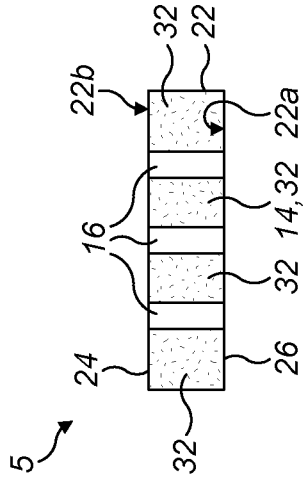

FIG. 8

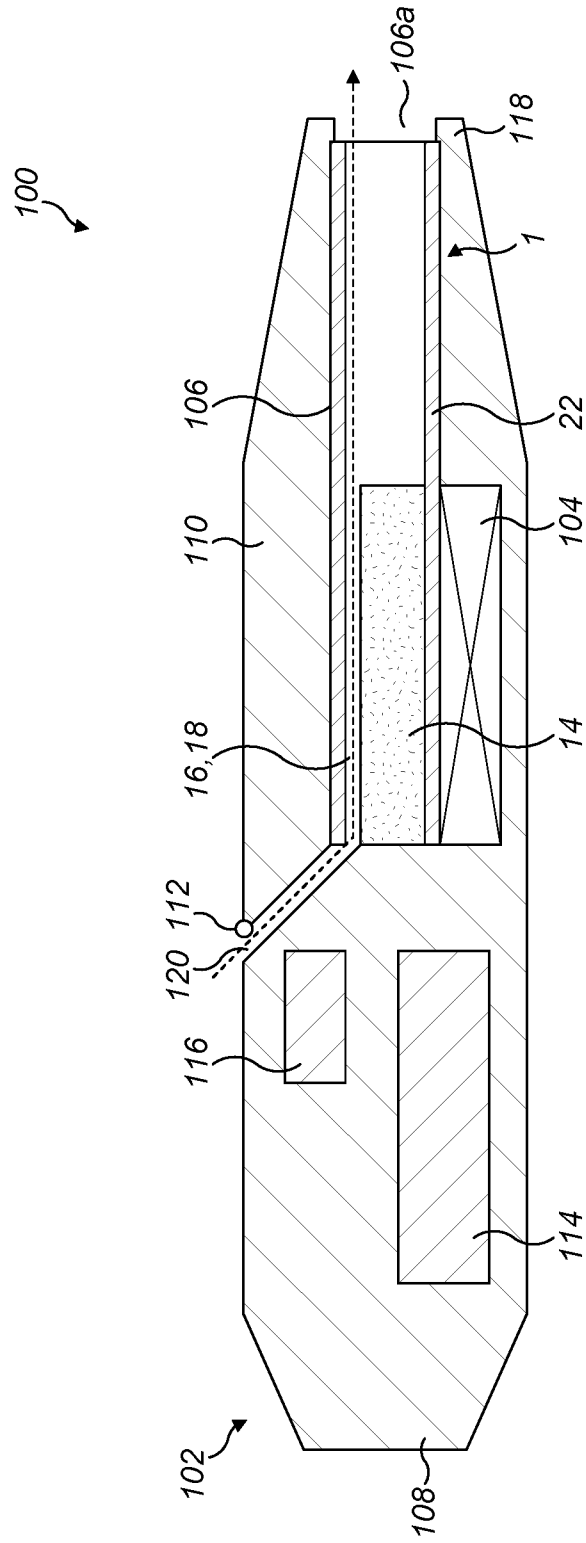

FIG. 9

# INTERNATIONAL SEARCH REPORT

International application No  
**PCT/EP2022/060586**

**A. CLASSIFICATION OF SUBJECT MATTER**  
**INV. A24D1/20 A24F40/42**  
**ADD.**

According to International Patent Classification (IPC) or to both national classification and IPC

**B. FIELDS SEARCHED**

Minimum documentation searched (classification system followed by classification symbols)  
**A24D A24F**

Documentation searched other than minimum documentation to the extent that such documents are included in the fields searched

Electronic data base consulted during the international search (name of data base and, where practicable, search terms used)

**EPO-Internal, WPI Data**

**C. DOCUMENTS CONSIDERED TO BE RELEVANT**

Category*	Citation of document, with indication, where appropriate, of the relevant passages	Relevant to claim No.
<b>X</b>	<b>WO 2020/239599 A1 (JT INT SA [CH])</b> <b>3 December 2020 (2020-12-03)</b> <b>abstract</b> <b>figures 1-15</b> <b>page 16 - page 18</b>	<b>1-5, 10,</b> <b>11</b>
<b>X</b>	<b>WO 2020/020748 A1 (PHILIP MORRIS PRODUCTS SA [CH])</b> <b>30 January 2020 (2020-01-30)</b> <b>abstract</b> <b>figures 1, 3, 6, 7</b> <b>page 6, line 1 - line 7</b> <b>page 11 - page 16</b>	<b>1, 2, 5-11</b>
	----- -/--	

Further documents are listed in the continuation of Box C.

See patent family annex.

\* Special categories of cited documents :

- "A" document defining the general state of the art which is not considered to be of particular relevance
- "E" earlier application or patent but published on or after the international filing date
- "L" document which may throw doubts on priority claim(s) or which is cited to establish the publication date of another citation or other special reason (as specified)
- "O" document referring to an oral disclosure, use, exhibition or other means
- "P" document published prior to the international filing date but later than the priority date claimed

- "T" later document published after the international filing date or priority date and not in conflict with the application but cited to understand the principle or theory underlying the invention
- "X" document of particular relevance; the claimed invention cannot be considered novel or cannot be considered to involve an inventive step when the document is taken alone
- "Y" document of particular relevance; the claimed invention cannot be considered to involve an inventive step when the document is combined with one or more other such documents, such combination being obvious to a person skilled in the art
- "&" document member of the same patent family

Date of the actual completion of the international search

Date of mailing of the international search report

**6 July 2022**

**25/07/2022**

Name and mailing address of the ISA/  
 European Patent Office, P.B. 5818 Patentlaan 2  
 NL - 2280 HV Rijswijk  
 Tel. (+31-70) 340-2040,  
 Fax: (+31-70) 340-3016

Authorized officer

**Juvenelle, Cyril**

## INTERNATIONAL SEARCH REPORT

International application No

PCT/EP2022/060586

C(Continuation). DOCUMENTS CONSIDERED TO BE RELEVANT		
Category*	Citation of document, with indication, where appropriate, of the relevant passages	Relevant to claim No.
X	WO 2020/127118 A1 (PHILIP MORRIS PRODUCTS SA [CH]) 25 June 2020 (2020-06-25) abstract figures 20,23,32 page 7 page 25, line 1 - line 6 page 40 - page 46 page 67 - page 76 -----	1, 2, 5, 11-13

# INTERNATIONAL SEARCH REPORT

Information on patent family members

International application No

**PCT/EP2022/060586**

Patent document cited in search report	Publication date	Patent family member(s)	Publication date
<b>WO 2020239599 A1</b>	<b>03-12-2020</b>	<b>CA 3141947 A1</b>	<b>03-12-2020</b>
		<b>CN 113966175 A</b>	<b>21-01-2022</b>
		<b>EA 202193242 A1</b>	<b>18-03-2022</b>
		<b>EP 3975764 A1</b>	<b>06-04-2022</b>
		<b>KR 20220013383 A</b>	<b>04-02-2022</b>
		<b>TW 202102147 A</b>	<b>16-01-2021</b>
		<b>WO 2020239599 A1</b>	<b>03-12-2020</b>
-----			
<b>WO 2020020748 A1</b>	<b>30-01-2020</b>	<b>BR 112020026833 A2</b>	<b>06-04-2021</b>
		<b>CN 112384086 A</b>	<b>19-02-2021</b>
		<b>EP 3826480 A1</b>	<b>02-06-2021</b>
		<b>JP 2021530990 A</b>	<b>18-11-2021</b>
		<b>KR 20210032970 A</b>	<b>25-03-2021</b>
		<b>US 2021212364 A1</b>	<b>15-07-2021</b>
		<b>WO 2020020748 A1</b>	<b>30-01-2020</b>
-----			
<b>WO 2020127118 A1</b>	<b>25-06-2020</b>	<b>BR 112021010478 A2</b>	<b>24-08-2021</b>
		<b>CN 113518561 A</b>	<b>19-10-2021</b>
		<b>EP 3897238 A1</b>	<b>27-10-2021</b>
		<b>JP 2022511513 A</b>	<b>31-01-2022</b>
		<b>KR 20210101222 A</b>	<b>18-08-2021</b>
		<b>US 2022022543 A1</b>	<b>27-01-2022</b>
		<b>WO 2020127118 A1</b>	<b>25-06-2020</b>
-----			