

(12) PATENT
(19) AUSTRALIAN PATENT OFFICE

(11) Application No. AU 200030558 B2
(10) Patent No. 767023

(54) Title
System for neutralising polluting gases by pyrolysis

(51)⁷ International Patent Classification(s)
B01D 053/81 F01N 003/26

(21) Application No: **200030558**

(22) Application Date: **2000.01.19**

(87) WIPO No: **WO00/43094**

(30) Priority Data

(31) Number	(32) Date	(33) Country
99 00483	1999.01.19	FR

(43) Publication Date : **2000.08.07**

(43) Publication Journal Date : **2000.10.12**

(44) Accepted Journal Date : **2003.10.30**

(71) Applicant(s)
Claude Roux

(72) Inventor(s)
Claude Roux

(74) Agent/Attorney
F B Rice and Co,605 Darling Street,BALMAIN NSW 2041

(56) Related Art
FR 2702004
GB 1396607
WO 90/04707

DEMANDE INTERNATIONALE PUBLIEE EN VERTU DU TRAITE DE COOPERATION EN MATIERE DE BREVETS (PCT)

<p>(51) Classification internationale des brevets ⁷ : B01D</p>	<p>A2</p>	<p>(11) Numéro de publication internationale: WO 00/43094 (43) Date de publication internationale: 27 juillet 2000 (27.07.00)</p>
<p>(21) Numéro de la demande internationale: PCT/FR00/00101 (22) Date de dépôt international: 19 janvier 2000 (19.01.00) (30) Données relatives à la priorité: 99/00483 19 janvier 1999 (19.01.99) FR (71)(72) Déposant et inventeur: ROUX, Claude [FR/FR]; 69, avenue Pierre Colongo, F-93290 Tremblay en France (FR). (74) Mandataire: DEJOUX, André; 33, rue de Fontarabie, F-75020 Paris (FR).</p>		<p>(81) Etats désignés: AU, BR, CA, CN, JP, MX, TR, US, brevet eurasien (AM, AZ, BY, KG, KZ, MD, RU, TJ, TM), brevet européen (AT, BE, CH, CY, DE, DK, ES, FI, FR, GB, GR, IE, IT, LU, MC, NL, PT, SE). Publiée <i>Sans rapport de recherche internationale, sera republiée dès réception de ce rapport.</i></p>

(54) Title: SYSTEM FOR NEUTRALISING POLLUTING GASES BY PYROLYSIS

(54) Titre: SYSTEME DE NEUTRALISATION DE GAZ POLLUANTS PAR PYROLYSE

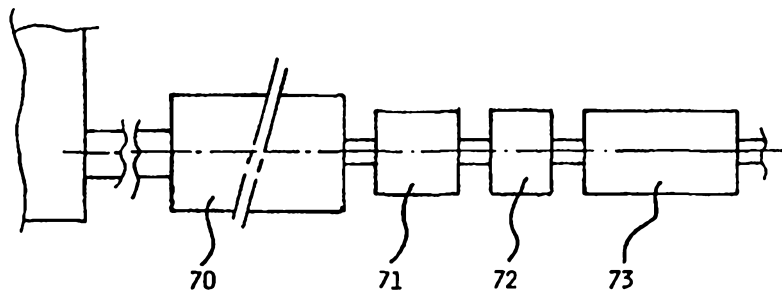

(57) Abstract

The invention concerns a system for neutralising polluting gases contained in particular in gas oil or gasoline internal engine exhaust gases, or stack effluents. It consists of mutually assembled or integrated modules, selected according to the polluting gas flow rate and their type, among all or part of the following modules: pyrolytic oven module (70) with hollow metal or mineral balls, comprising protuberances forming a very large exchange surface with the polluting gases, or with stacking of pyrolytic plates or electric resistors; module (71) for filtering particles and HC and for purifying polluting gases; module (72) for injecting a deodorant and neutralising liquid such as Zinc RINICEOLAT injected with compressed air ensuring its vaporisation; module (73) for abating noise and reducing gas temperature. For high or very high flow rates of polluting gases, the pyrolytic function is provided by an battery of pyrolytic ovens comprising an input manifold and an output manifold co-operating, when necessary, with a fume extractor.

SUMMARY

The invention concerns a system for neutralising polluting gases contained in particular in the exhaust gases of petrol or diesel internal combustion engines, or industrial smoke. It consists of
5 modules assembled together or integrated, chosen in accordance with the quantity of pollutant gases and their nature, from among some or all of the following modules: hollow metal or mineral sphere-type pyrolysis heat cell module (70), containing excrescences forming a very large exchange area with polluting gases, or electric heaters; particle and HC filter and polluting gas purification module (71), sound damping and gas temperature reduction module (73).

10

Summary drawing figure 19.

15

System for neutralising pollutant gases by pyrolysis

The invention concerns a system for neutralising pollutant gas by the pyrolysis of particles and soot in suspension, emitted in particular by petrol or diesel internal combustion engines, or by all types of industrial combustion emitting noxious smoke, for example waste incineration plants.

It is known in particular that the combustion of fuels feeding petrol or diesel internal combustion engines can never be balanced and complete in particular because of a lack of air at the transient instant and the presence mainly of noxious substances in the exhaust gas such as carbon monoxide CO, unburnt or partially burnt hydrocarbons HC, nitrogen oxides NO_x and solids such as particles and soot. The appearance of particles and soot results from carburetion with too little air. It occurs notably at transients: moving off when traffic lights change to green, changes of speed on the level, on hills and when accelerating.

Systems are already known for processing these pollutants such as "catalytic converters on cars and more recently on diesel lorries, employing catalysts designed to oxidise mainly the carbon monoxide, unburnt or partially burnt hydrocarbon residues and nitrogen oxide NO_x.

The drawbacks shown by this type of system lie in particular in the difficulty of choosing an effective metal or metal oxide catalyst to accelerate these reactions. A catalyst that reduces the NO_x beyond N₂, into N₃H, is not suitable because the ammonia released into the atmosphere re-oxidises into NO_x. Another important drawback of this system appears when an internal combustion engine starts from cold until the catalytic converter reaches optimal running temperature. During this period, emissions of pollutants not only are not reduced, but are increased. This drawback requires costly, noble metals to be chosen such for example as platinum which acts at low temperature. In addition, the sulphur SO₂ in petrol is oxidised into SO₃ by the catalyst, which generates sulphuric acid. In general, catalytic converters are very expensive, reduce engine power, increase fuel consumption by adding an additional weight to the vehicles empty weight, they only neutralise part of the pollutants and their effectiveness is limited. As regards "gas washing" processes, they are excessively costly.

Systems designed to destroy by combustion the particles in the polluting exhaust emitted from diesel engines are also known. This combustion allows toxic carbon residues to remain. Particle filters are also known, but they block very quickly and need to be changed or a regeneration system to be added which increases the cost.

5 Document WO 92 14042 A describes a polluting gas neutralisation system consisting of a pyrolysis heat cell arranged to retain and destroy residues from incomplete combustion by means of presenting a large exchange area.

Document RF-A-2 702 004 mentions that on heat destruction by pyrolysis of residues from incomplete combustion, that they are only partly oxidised which produces dust. It also mentions a
10 means of noise abatement during the pyrolysis of residues from incomplete combustion.

Document DE 14 76 627 A discloses a filtration device combining filtering units (37, 44, 46) and noise abatement units.

Document GB-A-1 396 607 describes a polluting gas neutralisation system consisting of a pyrolysis heat cell consisting of an interchangeable linear electric heater assembly (26a to 26 e)
15 spanning the heat cell between insulating plates (45). The exchange area of these heating elements with the pollutants crossing the heat cell is low and not very efficient.

Document WO 90 04 707 describes a polluting gas neutralisation system consisting of a stack of metal plates each of them carrying on its surface multiple excrescences, the said plates being coiled in a spiral and inserted into the chamber of a cylindrical pyrolysis heat cell. The said plates
20 can be run as electrical heaters.

The problem to be solved consists particularly of:

- providing a simple, durable system considerably reducing the emission of polluting gases from internal combustion engines and from various factories, to a level very much lower than those already obtained by existing systems meeting the strictest standards;
- 25 • providing the system at a cost equal and preferable less than that of traditional means of equal effectiveness;

- not introducing any loss of power that increases fuel consumption and reduces power in the case of internal combustion engines;
- substantially increasing the life of the system;
- reducing the emission of polluting gasses from various industrial processes (waste incineration plants, oil fired municipal heating or even domestic oil fired heating and all types of emissions of noxious smoke containing various particles in suspension that can be destroyed by pyrolysis).

The system according to the invention is intended to counter the aforementioned drawbacks, solve the problem posed above and provide a range of means of effectively reducing pollutants emitted by diesel or petrol internal combustion engines, covering a broad part of the power range of existing fixed or mobile engines on the market, the system being adaptable to the pyrolysis of industrial smoke.

The system according to the invention consists of a means of neutralising polluting gases consisting of a pyrolysis heat cell arranged to retain and destroy the residues from incomplete combustion, by the intermediary of means presenting a very large exchange area at pyrolysis temperature with the said gases. The said exchange and pyrolysis area being made to almost instantly reach the temperature of the said exhaust gases once the internal combustion engine is started up.

Under a first method of construction, the exchange and pyrolysis area consists of a set of spheres each containing, over its entire surface, numerous excrescences (1, 2, 3) for example of diamond pointed type or similar. The spheres, each bearing numerous excrescences, are machined from limestone or any other kind of rock. The spheres can also be obtained by moulding mineral powder, preferably limestone.

The spheres with their excrescences can be stamped out as two welded parts, from a metal with a high coefficient of heat transmission, as sheets of very low thickness. The spheres are processed to size and put into a pyrolysis heat cell of corresponding size.

In accordance with a second variant of construction, the means of neutralising polluting gases presenting a very large exchange area consists of a stack of very thin metal plates of high coefficient of heat transmission, each carrying, over its entire area, numerous preferably identical excrescences,

stamp staggered compared to the gas flow direction. These pyrolysis plates are put into an insulated heat cell of a rectangular or square section.

In accordance with a third variant of construction, the means of neutralising polluting
 5 gases presenting a very large exchange area consists of a single pyrolysis plate wound as a spiral and put into the chamber of an insulated cylindrical heat cell. The spiral plate is brought up to temperature by switching it on just before the engine is started up, by using it as an electrical heater.

10 In accordance with a fourth variant of construction, the means of neutralising polluting gases consists of a set of interchangeable electrical heaters wound flat as spirals and stacked in an insulated enclosure. The pyrolysis exchange area is brought up to temperature, when the engine is started up, by a discharge from condensers of adequate capacity. To prevent heat losses, the pyrolysis heat cell is arranged as close as possible
 15 to the engine and is fully insulated as is the exhaust gas pipe between the internal combustion engine and the said pyrolysis heat cell.

The system according to the invention consists of modules assembled together or integral, chosen in accordance with the amount and type of polluting gases, from some
 20 or all of the following modules: pyrolysis heat cell module, particle and HC filtration and polluting gas purification module, silencer and gas temperature reduction module.

For high or very high quantities of polluting gases, the pyrolysis function is provided by a battery of heat cells containing an input collector and an output collector which, when
 25 necessary, work together with a smoke extractor.

In a first aspect, the present invention provides pollutant neutralising system contained in gases emitted in particular by internal combustion engines including a pyrolytic heat cell arranged to retain and destroy pollutants, through means presenting a very large
 30 exchange area at the temperature of pyrolysis with the said pollutants; characterised in that the means of neutralising by pyrolysis presenting a very large exchange area with the said pollutants, consists of an assembly of spheres each containing, over its entire surface, numerous excrescences.

35 In a second aspect, the present invention provides pollutant neutralising system contained in gases emitted in particular by internal combustion engines including a

pyrolitic heat cell arranged to retain and destroy pollutants, through means presenting a very large exchange area at the temperature of pyrolysis with said pollutants; characterised in that pyrolitic heat cell for neutralising pollutants contains means with a very large exchange area, these means consist of a set of interchangeable electric
5 heaters wound on themselves as flat spirals and stacked in an insulated chamber.

Any discussion of documents, acts, materials, devices, articles or the like which has been included in the present specification is solely for the purpose of providing a context for the present invention. It is not to be taken as an admission that any or all of
10 these matters form part of the prior art base or were common general knowledge in the field relevant to the present invention as it existed before the priority date of each claim of this application.

The advantages of the present invention are as follows:

- 15
- Very substantial reduction in polluting gases;
 - Longer life than traditional exhaust converters because of the absence of water vapour and continuous regeneration by vibration of the pyrolysis heat cell;
 - Possibility of making very compact extra-thin systems for all engine powers;
 - No loss of engine power;

20

 - No excess fuel consumption;
 - Little added weight compared to traditional exhaust converters;

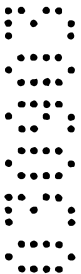

- Is operational from when the engine starts up;
- Suitable for all stationary engines
- Can be used for reducing industrial smoke and smoke from oil central heating facilities.

The invention is described in detail in the text below, in reference to the appended drawings
5 that are provided as non-limiting examples, in which:

- figures 1 to 4 show diagrammatic examples of means of producing the pseudo-spherical exchange and pyrolysis surfaces of the system according to the invention for a diesel or petrol engine;
- figures 5, 6 and 7 show diagrammatic cross-section examples of the pseudo-flat exchange and
10 pyrolysis surfaces of the system according to the invention for a diesel or petrol engine;
- figure 8 shows, seen from above, a diagrammatic example of the arrangement of the hemispherical or cylindrical excrescences as in figures 6 and 7 intended to retain and heat unburnt or partly burnt particles or HC of the system according to the invention;
- figure 9 shows, seen from above, a diagrammatic example of the arrangement of the
15 excrescences known as diamond point as in figure 5 intended to retain and heat unburnt or partly burnt particles or HC of the system according to the invention;
- figure 10 partially shows a diagrammatic example of the stacking of thin metal plates bearing cylindrical excrescences intended to retain and heat unburnt or partly burnt particles or HC of the system according to the invention;
- figure 11 shows diagrammatically the spiral winding of a thin metal plate bearing
20 excrescences intended to retain and heat unburnt or partly burnt particles or HC of the system according to the invention;
- figures 12 and 13 show a diagrammatic example of the construction of an exchange and pyrolysis surface consisting of a set of electrical heater elements wound in a flat spiral, as front view and side view cross-sections;
25
- figure 14 shows diagrammatically, as a front view cross-section, an example of the construction of the exchange and heating surface consisting of a set of hollow metal spheres, bearing excrescences, in place in a sealed, insulated chamber;

- figure 15 shows diagrammatically, as a front view cross-section, an example of the construction of the exchange and pyrolysis surface consisting of a set of mineral metal spheres bearing excrescences, in place in a sealed, insulated chamber after placement between them of a metal sock and flat rings consisting of stainless steel swarf;
- 5 • figures 16 and 17 show diagrammatically, as an end cross-section and as a front view cross-section, an example of the heating heat cell containing exchange and heating surfaces consisting of a set of plates bearing excrescences, in place in a sealed, insulated chamber;
- figure 18 shows diagrammatically, as a front view, an example of the known type of catalytic converter;
- 10 • figure 19 shows diagrammatically, as a front view, an example of the complete pyrolysis converter in accordance with the invention for heavy goods vehicles, buses and coaches, heavy plant, etc.;

As shown in **figures 1 to 3**, the example of the large exchange and pyrolysis surface in accordance with the invention to dry exhaust gases, retain and quickly pyrolyse unburnt or partially burnt particles and HC, consists of excrescences machined on the surface of mineral spheres. The shape of these identical excrescences is preferably one that offers the greatest exchange area with the gases. They may, for example, be “diamond pointed” 2, more keenly pointed 1 (Isosceles pyramids) or hemispherical 3 or other shapes easy to achieve by machining or moulding mineral dust such as limestone under pressure. By moulding, it is possible to get other shapes bearing these excrescences other than spheres, but spheres are preferable because they provide the greatest exchange area at equal volume and facilitate the circulation of gases.

Figure 4 shows an example of the hollow sphere made of thin metal, about 4 mm thick, bearing diamond pointed excrescences, stamped in halves (6 and 7) and electric or ultrasonic welded for example. The material is to be chosen from ones providing the best coefficient of heat transmission and corrosion-resistance to exhaust gasses and other toxic emissions. As an example, the diameter of the spheres is around 20 mm for cars, 50 mm for

coaches and 60 mm for heavy goods vehicles. The quantity of spheres depends on the throughput of pollutants to be neutralised.

The primary function of the excrescences is to reduce the thermal inertia of the surface of the spheres such that they almost instantly reach the temperature of the exhaust gases once the internal combustion engine is started up, it not being necessary to heat the spheres right through to be effective. They form a mass of accumulated heat. The secondary function of the excrescences is to increase the exchange area with the gases and retain passing unburnt or partially burnt particles and residues that adhere to the excrescences more readily with diminishing size and heat more quickly. The third function of the excrescences is to facilitate the throughput of gases by preventing the occurrence of a loss of charge reducing the power of the engine.

The pyrolysis of particles and soot considerably reduces their volume, or even makes them almost totally disappear. After pyrolysis, particle residues no longer contain toxic carbon CO which is converted into non-toxic CO₂. HC are also converted by the pyrolysis and become harmless. The water H₂O produced by combustion of the fuel is eliminated on passing through the spheres. The very low particle and HC residues end up by being released due to the vibrations caused by driving and gasses moving through, which continuously regenerates the exchange surfaces. This very low volume of residues is driven by the pressure of the gases into the following filter part.

Hollow mineral or metal spheres represent a first means of producing the exchange and pyrolysis surface. In the specific case of large diameter spheres, the throughput apertures between the spheres are large and liable to allow un-neutralised or insufficiently neutralised particles and soot to pass.

Figures 5 to 11 show another model for producing very large exchange surfaces much more compact and regular than with spheres. Figures 5, 6 and 7 show examples of excrescences of various known shapes on spheres: diamond pointed 10, hemispherical 11 or cylindrical 12, stamped on flat surfaces, preferably arranged as a mesh 15 staggered in accordance with an angle for example of 45° compared to the direction 16 of gas flow, to avoid direct tunnels.

The staggered arrangement makes the gases follow a route including a number of obstacles against which particles and soot are thrown and fragment because of the impact due to the speed of the gases, mainly at the start of the circuit reducing their size and adhering to the excrescences at a temperature of around 800 to 900 degrees C, on which they are converted chemically and reduced to inert residues of very low volume. The length of travel of the gases in the pyrolysis heat cell is arranged such that almost all of the particles and soot are neutralised. These low residues then detach because of vibration and are then removed by the pressure of the gases in the following filter.

Figure 9 shows an example of the arrangement of the excrescences stamped as diamond points on a plate 20. The diamond points are arranged such that no flat parts remain on the plate 20 except locally at the edges.

This arrangement provides the largest possible exchange surface while allowing vibration to be limited. In the instance of diamond points, some of them have been omitted from place to place to allow them to be stacked by allowing a space to remain of point height for gases to circulate. The height of the points or excrescences is calculated in accordance with the maximum throughput of exhaust gases to prevent load losses.

Figure 10 shows a partial stack of pyrolysis plates with closed cylindrical shaped excrescences 12 arranged staggered intended to completely fill the pyrolysis heat cell.

Figure 11 shows an example of the cylindrical pyrolysis heat cell 21 consisting of a pyrolysis plate 22 in figures 5, 6 or 7, wound with no centre and banded, put into the chamber 23 of the heat cell containing insulation 24, onto which the roll is located by force, or is enclosed in a stainless steel sock 25 before it is put into the heat cell. The structure of the heat cell is identical to that of the heat cells in the following figures.

Figures 12 and 13 show diagrammatically a front cross-section and side cross-section of an example of the pyrolysis heat cell 29 consisting of a cylindrical chamber 30 wrapped with insulating material 31, in which a set of identical electric heaters is arranged 32 wound in a flat spiral fitted with a space 33 between them. The electric heaters can be assembled in various known ways.

The gas inlet 34 and outlet 35 closure flanges preferably form a cone opening onto the gas inlet 36 and outlet 37 pipes. The well known electrical insulation and skin bushing method is not shown. The temperature of the heaters is calibrated in accordance with the nature of the pollutants to be reduced by pyrolysis. The number of heaters and diameter of the heat cell depend
5 on the throughput of gas. For maintenance, this type of heat cell is fitted with interchangeable heaters. Each ceramic ring carrier for a heater with its usual means of fixing, contains for example two shoulders the reverse way around, which enables them to be successively seated. The heaters are connected for example by terminals. The insulated chamber can be made as two half shells so can be dismantled and faulty heaters changed.

10 This type of heat cell can be used for a large number of industrial applications independent of the pyrolytic exhaust gas converter application for internal combustion engines, in particular for large oil-fired heating plants that also emit a lot of soot and notably contribute to urban pollution. For very high outputs of industrial smoke, for example from waste incineration plants, batteries of pyrolytic heat cells can be installed with an inlet collector and an outlet connector, working with a
15 smoke extractor to prevent back pressure when outlet speed is low.

The benefit of this type of heat cell lies in the fact that it is possible to accurately control the temperature of pyrolysis as required.

Figure 14 shows diagrammatically a front cross-section of an example of the cylindrical pyrolysis heat cell 39 enclosed in insulation 40, whose exchange surface consists of a set of
20 hollow metal spheres 7 bearing excrescences, previously adjusted to the size of the heat cell in a stainless steel net, located by crimping the closure skin 41 or 42. The number and diameter of the spheres and diameter and length of the heat cell depend on the quantity and nature of the gases (petrol, diesel or others in applications other than engines).

Figure 15 shows diagrammatically a front cross-section of an example of the cylindrical pyrolysis heat cell 44 containing a sealed skin 45 enclosed in insulation 46, whose exchange surface consists of a set of mineral spheres 1, 2 or 3, carrying excrescences, previously adjusted to the size of the heat cell in a stainless steel net, and inserted in a sock 47, located before
5 crimping of the closure skin 48 or 49 after insertion of flat rings 50, 51 consisting of a meshed stainless steel wire, presenting in cross section three very sharp edges, also previously enclosed in a stainless steel net. The particles and soot are fragmented by impact on its successive edges through its meshing in the flat ring. The wire can be obtained in the form of continuous lathe swarf. It is then meshed. Because of its nature, the flat ring acts as a sound damper to lower the
10 noise level of the exhaust gases.

The number and diameter of the spheres and the length and diameter of the heat cell depend on the quantity of gases and their nature (petrol, diesel or others in applications other than vehicle engines).

Figures 16 and 17 show diagrammatically an end cross-section and front cross-section
15 of another example of the pyrolysis heat cell 55 containing exchange surfaces consisting of a set of pyrolysis plates 56 in accordance with one of the figures 5, 6 or 7, bearing excrescences 10, 11 or 12, in place in a sealed chamber 57 surrounded by insulation 58 of rectangular cross-section; consisting of a gas inlet pipe 59 and outlet pipe 60 offset in relation to one another. This type of pyrolysis heat cell is much more compact than sphere-type pyrolysis heat cell because the entire
20 volume is used for exchange with the gases, which is not the case with the volume within the spheres.

Figure 18 shows a traditional catalytic converter configuration consisting of a catalyst module 65, an intermediate filter module 66 and a noise damping silencer module 67.

Figure 19 shows diagrammatically the fullest configuration of the system in accordance
25 with the invention for high powered engines. This configuration consists of modules assembled with one another by crimping their inlet pipe and outlet pipe. The same type of module can be produced according to a range of different lengths and/or cross-sections, which enables systems to be made to suit the throughput, the nature of gases and density of their load of particles or soot to be heated, for

predetermined power ranges, by the choice of some or all of the following modules: a neutralisation by pyrolysis module 70.

5 The function of the filter module can also be provided for example by an accordion carbon filter-type paper also enclosed in a stainless steel net. The job of the volume of the carbon filter is to retain the very fine pyrolysis residues from the previous means, to continue the reduction of residual gaseous components that they may contain, and to purify residual gaseous pollutants as they pass through, to continue their neutralisation; a deodorising and neutralising gas injection module 72.

THE CLAIMS DEFINING THE INVENTION ARE AS FOLLOWS:

1. Pollutant neutralising system contained in gases emitted in particular by internal combustion engines including a pyrolitic heat cell arranged to retain and destroy pollutants, through means presenting a very large exchange area at the temperature of pyrolysis with the said pollutants; characterised in that the means of neutralising by pyrolysis presenting a very large exchange area with the said pollutants, consists of an assembly of spheres each containing, over its entire surface, numerous excrescences.
2. Pollutant neutralising system in accordance with claim 1 wherein the excrescences are of diamond point shape or the like.
3. Pollutant neutralising system in accordance with claim 1 or claim 2, characterised in that the spheres all containing, over their entire surface, numerous excrescences, are machined from rock of any kind whatever.
4. Pollutant neutralising system in accordance with any one of the preceding claims, characterised in that the spheres each containing, over their entire surface, numerous excrescences, are machined from limestone rock.
5. Pollutant neutralising system in accordance with any one of the preceding claims, characterised in that the spheres all containing, over their entire surface, numerous excrescences, are moulded from limestone mineral powder.
6. Pollutant neutralising system in accordance with any one of the preceding claims, characterised in that the spheres all containing, over their entire surface, numerous excrescences, are stamped as halves from a sheet of metal 0.4 mm thick and then welded together.
7. Pollutant neutralising system contained in gases emitted in particular by internal combustion engines including a pyrolitic heat cell arranged to retain and destroy pollutants, through means presenting a very large exchange area at the temperature of pyrolysis with said pollutants; characterised in that pyrolitic heat cell for neutralising pollutants contains means with a very large exchange area, these means consist of a set of interchangeable electric heaters wound on themselves as flat spirals and stacked in an insulated chamber.

8. Pollutant neutralising system in accordance with any one of claims 1 to 6, characterised in that the exchange and pyrolysis surface of the pyrolytic heat cell consists of an assembly of hollow metal spheres furnished with excrescences filling its chamber.
- 5
9. Pollutant neutralising system in accordance with any one of claims 1 to 5, characterised in that the means presenting the exchange and pyrolysis surface of the heat cell consists of a set of mineral spheres furnished with excrescences, enclosed in a stainless steel net and put into the heat cell's chamber after the insertion of flat rings intended to fragment by large unburnt or partially burnt particles or HC, consisting of a mesh of stainless steel swarf, preferably arranged ahead of the pyrolysis spheres.
- 10
10. Pollutant neutralising system in accordance with anyone of claim 7 wherein each of said heaters are surrounded by a tubular ceramic insulating chamber comprised of a plurality of rings having two shoulders oriented in reversed relation to one another to enable the rings to interfit with one another so as to form the tubular insulating chamber.
- 15
11. Pollutant neutralising system in accordance with claims 7 to 10 wherein heaters of decreasing diameter are arranged in a substantially concentric fashion within each ceramic ring.
- 20
12. Pollutant neutralising system in accordance with any one claims 7 to 11 wherein the insulating chamber is comprised of two halves capable of being dismantled thereby providing access to the heaters.
- 25
13. Pollutant neutralising system in accordance with any one of the preceding claims substantially as hereinbefore described with particular reference to the preferred embodiments and/or the figures.
- 30

Dated this twenty-ninth day of August 2003

Claude Roux
 Patent Attorneys for the Applicant:
 F B RICE & CO

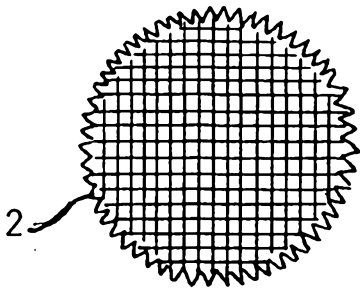

FIG. 1

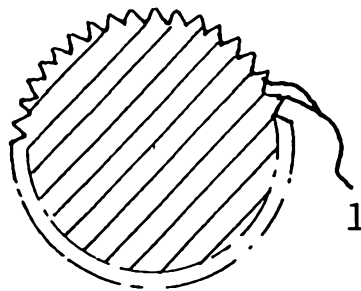

FIG. 2

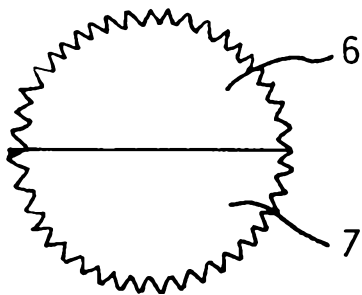

FIG. 4

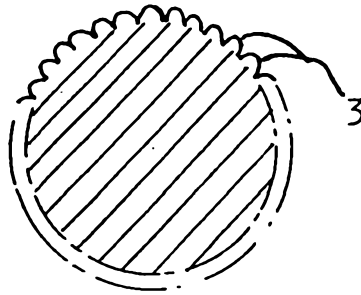

FIG. 3



FIG. 5

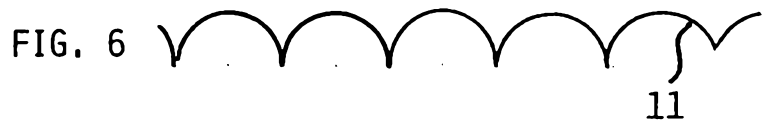

FIG. 6

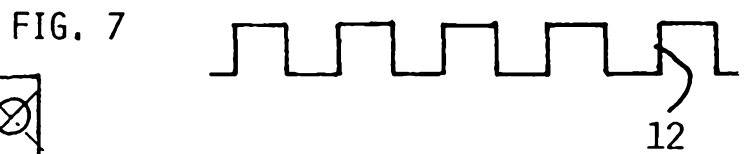

FIG. 7

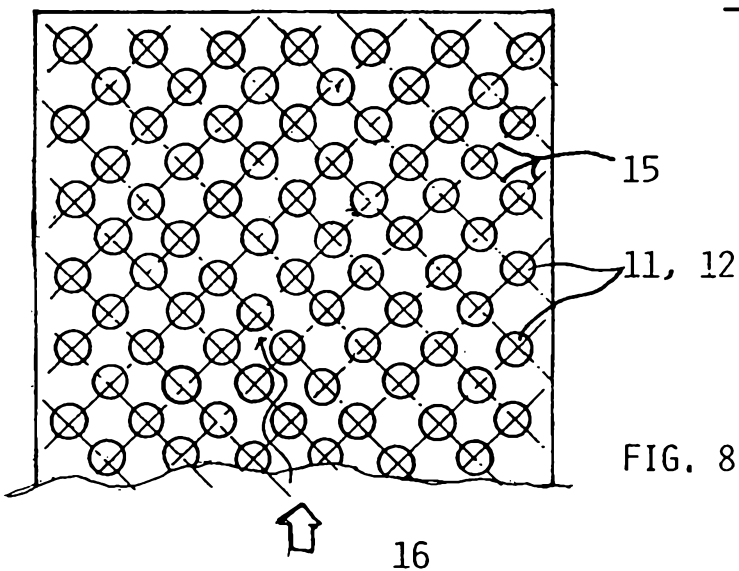

FIG. 8

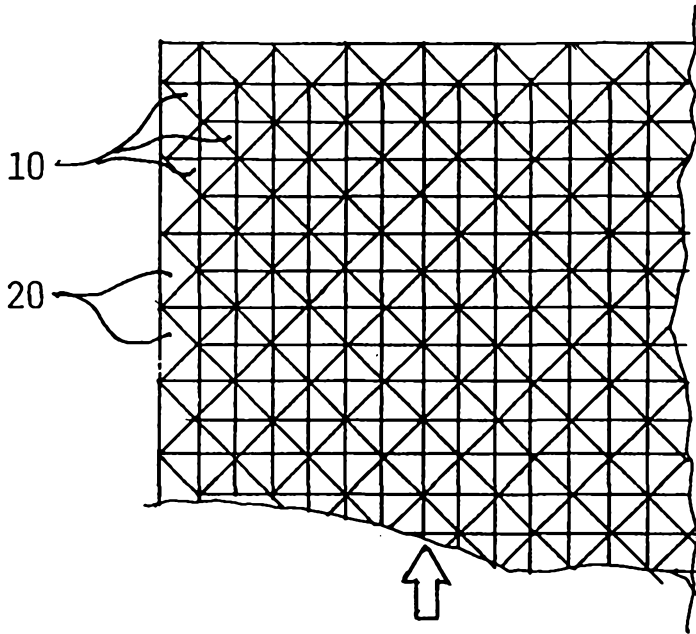

FIG. 9

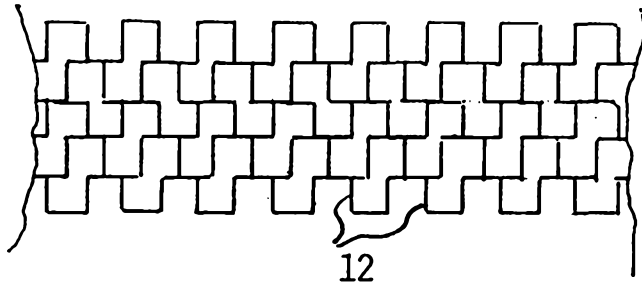

FIG. 10

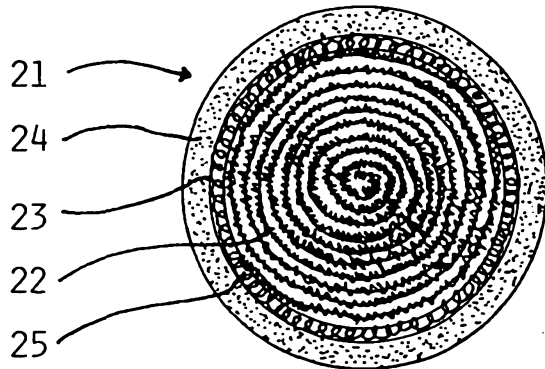
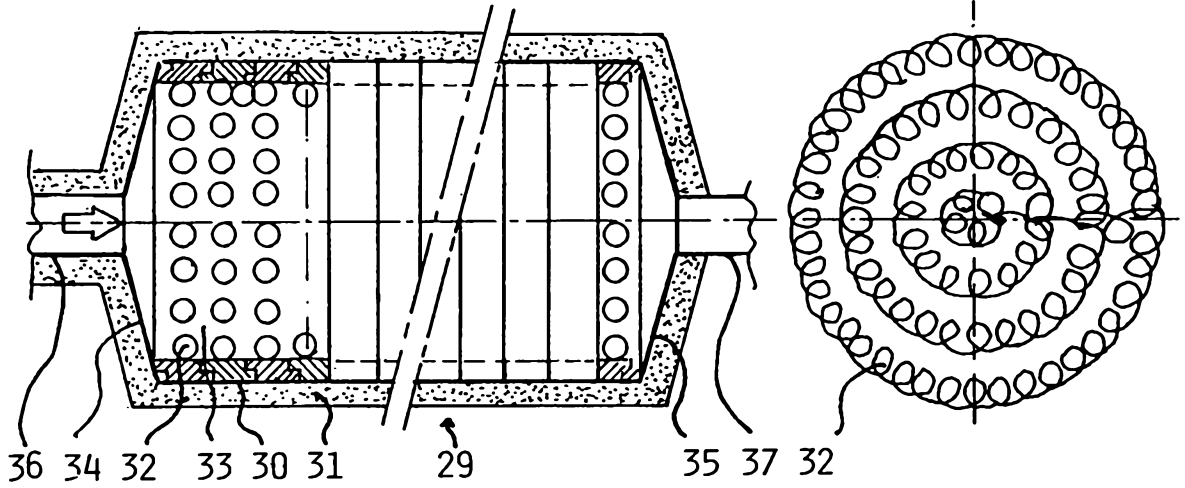

FIG. 11

FIG. 12

FIG. 13



36

FIG. 14

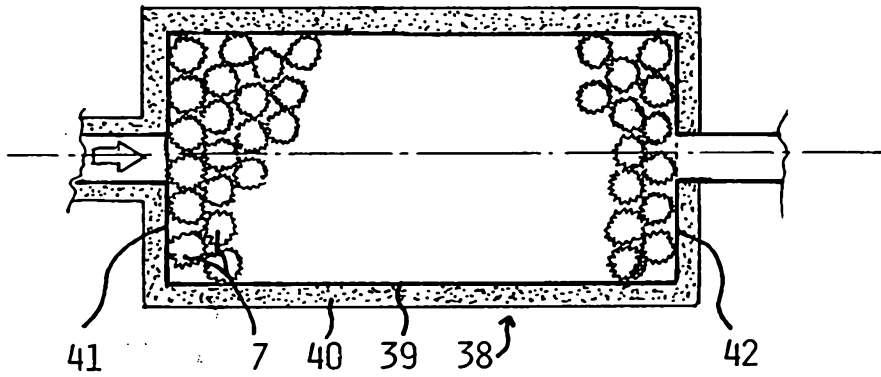

FIG. 15

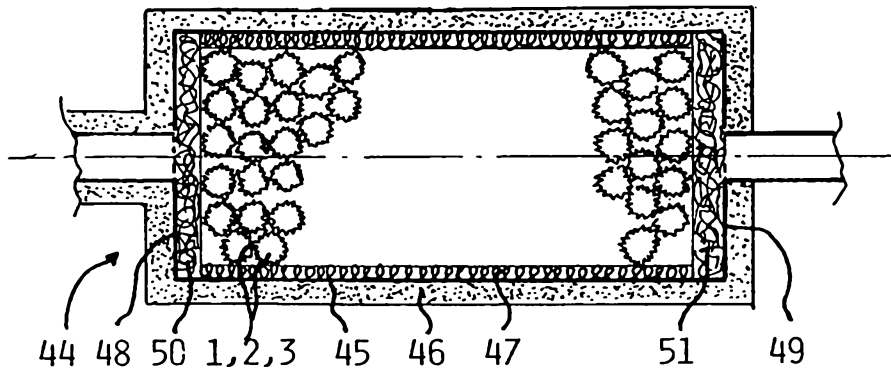

FIG. 16

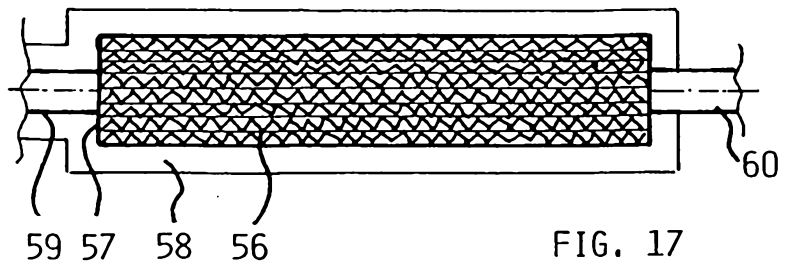
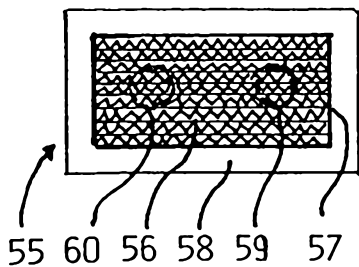

FIG. 17

FIG. 18

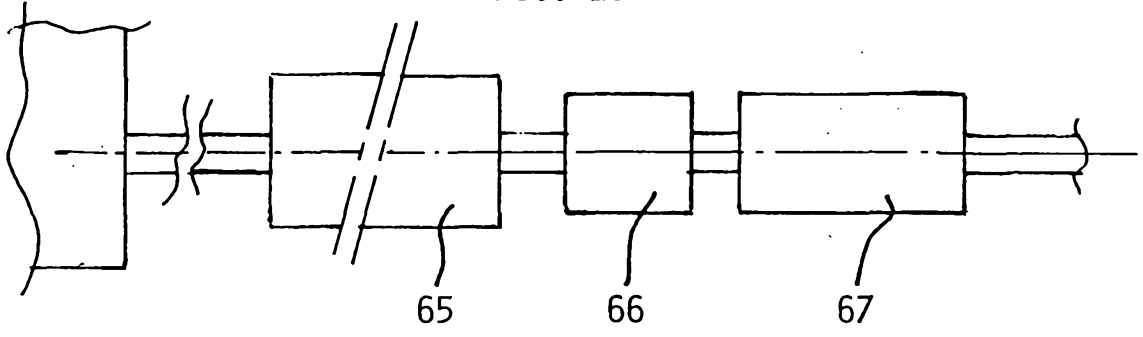

FIG. 19

