



## INTERNATIONAL APPLICATION PUBLISHED UNDER THE PATENT COOPERATION TREATY (PCT)

<p>(51) International Patent Classification<sup>5</sup> : C12Q 1/00, G01N 35/00, 21/00</p>	<p>A1</p>	<p>(11) International Publication Number: <b>WO 94/16095</b></p> <p>(43) International Publication Date: 21 July 1994 (21.07.94)</p>
<p>(21) International Application Number: PCT/US94/00393</p> <p>(22) International Filing Date: 12 January 1994 (12.01.94)</p> <p>(30) Priority Data: 08/003,771 13 January 1993 (13.01.93) US</p> <p>(71) Applicant: AVOCET MEDICAL, INC. [US/US]; 15466 Los Gatos Boulevard, Suite 109-58, Los Gatos, CA 95032 (US).</p> <p>(72) Inventor: ZWEIG, Stephen, E.; 16615 Ferris Avenue, Los Gatos, CA 95032 (US).</p> <p>(74) Agent: HESLIN, James, M.; Townsend and Townsend Khourie and Crew, Steuart Street Tower, 20th floor, One Market Plaza, San Francisco, CA 94105 (US).</p>	<p>(81) Designated States: AU, BR, CA, FI, HU, JP, KR, NO, NZ, PL, RU, UA, European patent (AT, BE, CH, DE, DK, ES, FR, GB, GR, IE, IT, LU, MC, NL, PT, SE).</p> <p><b>Published</b> <i>With international search report.</i></p>	
<p>(54) Title: METHOD, TEST ARTICLE, AND SYSTEM FOR PERFORMING ASSAYS</p>		
<p>(57) Abstract</p> <p>Assays for liquid analytes are performed on a bibulous matrix containing dried reagents which produce a visibly detectable reaction product. Application of liquid sample to the bibulous matrix is detected by measuring a drop in resistance across the matrix. A preferred test article for performing the method includes the matrix and a pair of spaced-apart electrodes in electrical contact with a reaction zone on the matrix. The test article is used in combination with a detection unit having means for probing the electrodes to determine when electrical resistance in the matrix has decreased. The assay methods and apparatus are particularly useful for performing enzyme assays where signal developed as a function of time is critical.</p>		

*FOR THE PURPOSES OF INFORMATION ONLY*

Codes used to identify States party to the PCT on the front pages of pamphlets publishing international applications under the PCT.

AT	Austria	GB	United Kingdom	MR	Mauritania
AU	Australia	GE	Georgia	MW	Malawi
BB	Barbados	GN	Guinea	NE	Niger
BE	Belgium	GR	Greece	NL	Netherlands
BF	Burkina Faso	HU	Hungary	NO	Norway
BG	Bulgaria	IE	Ireland	NZ	New Zealand
BJ	Benin	IT	Italy	PL	Poland
BR	Brazil	JP	Japan	PT	Portugal
BY	Belarus	KE	Kenya	RO	Romania
CA	Canada	KG	Kyrgyzstan	RU	Russian Federation
CF	Central African Republic	KP	Democratic People's Republic of Korea	SD	Sudan
CG	Congo	KR	Republic of Korea	SE	Sweden
CH	Switzerland	KZ	Kazakhstan	SI	Slovenia
CI	Côte d'Ivoire	LI	Liechtenstein	SK	Slovakia
CM	Cameroon	LV	Latvia	SN	Senegal
CN	China	LK	Sri Lanka	TD	Chad
CS	Czechoslovakia	LU	Luxembourg	TG	Togo
CZ	Czech Republic	LV	Latvia	TJ	Tajikistan
DE	Germany	MC	Monaco	TT	Trinidad and Tobago
DK	Denmark	MD	Republic of Moldova	UA	Ukraine
ES	Spain	MG	Madagascar	US	United States of America
FI	Finland	ML	Mali	UZ	Uzbekistan
FR	France	MN	Mongolia	VN	Viet Nam
GA	Gabon				

**METHOD, TEST ARTICLE, AND SYSTEM FOR  
PERFORMING ASSAYS**

**BACKGROUND OF THE INVENTION**

5     **1. Field of the Invention**

The present invention relates generally to methods and apparatus for detecting analytes in liquid samples. More particularly, the present invention relates to assays for detecting enzymes and components of enzyme pathways where both the time and temperature of the assay are controlled.

Enzymes and enzymatic pathways play an important role in medicine and are the subject of many clinical tests. Examples of tests for single enzymes include tests for amylase, creatine kinase, alanine aminotransferase, aspartate aminotransferase, streptokinase, and thrombin. Examples of tests for enzymatic pathways include the prothrombin time test, and the activated partial thromboplastin time test. These later tests measure the enzymatic pathways involved in the extrinsic and intrinsic blood coagulation systems.

Tests involving enzymatic reactions tend to be technically demanding. Enzymes and enzymatic pathways are typically assayed by measuring the rate at which the enzyme or enzymatic pathway in question converts a particular enzymatic substrate into its product. Such rate measurements require precise test timing since timing errors are directly translated into errors in the calculated amount of enzyme or component in an enzyme pathway.

Temperature control is also critical since most enzymes have reaction rates that change dramatically as a function of temperature. Typically, higher temperatures produce a higher reaction rate, and lower temperatures produce a lower reaction rate. Enzymatic pathways, consisting of a number of temperature sensitive enzymatic

steps, are often extremely temperature sensitive as a result of the cascade effect.

Because of these technical demands, most enzyme and enzymatic pathway tests have tended to be complex, with performance generally limited to clinical laboratories. While such centralized testing may be adequate for infrequent, or routine medical conditions, visiting a doctor's office or a clinic on a regular basis for frequent or emergency medical tests is less acceptable. Thus there exists a need for convenient and simple tests, that can be performed by unskilled users for the measurement of enzymes and enzyme pathways.

A variety of simplified "test-strip" assays have been developed to allow semi-skilled and unskilled users to detect analytes, such as pregnancy hormones, cholesterol, and glucose in urine, blood, and other patient samples. These test strip assays are most useful with non-enzymatic analytes where detection does not vary with minor fluctuations in test time or temperature. As previously discussed, enzymatic reactions are less tolerant, and require more precise control over these variables, generally rendering them unsuitable for use in the home or other non-clinical environment.

One such test strip for performing blood glucose analysis, available from LifeScan Inc., Milpitas, California, relies on applying a drop of blood to a polyamide membrane having impregnated reagents which produce a chromogenic reaction in response to the glucose level in applied blood. Simplified low-cost tests such as this are often referred to as "home tests", to designate the fact that they have achieved a price and simplicity level that would allow widespread adoption in non-professional settings.

For these reasons, it would be desirable to provide simplified assays, test articles, and test systems for detecting problematic analytes, such as enzymes and components of enzyme pathways in a variety of

patient samples, such as blood, urine, and the like. In particular, the test articles and test systems should permit simplified assay protocols, preferably allowing for an automatic timing cycle which is initiated as soon as a sample is applied to a test article. The test articles and test systems should optionally also facilitate providing precise temperature control of a test region on the article, preferably without the need to enclose the test article in a heated chamber or other structure which limits the user access. The assays, test articles, and test systems should be readily usable with small sample volumes, particularly with small blood volumes such as a single blood drop. The test articles should further inhibit loss of the patient sample from the test article by evaporation or other means, particularly when using very small sample volumes. The test article and test system should still further provide for monitoring of the presence of sample within the test article and be able to warn the user when excessive amounts of sample have been lost. Such test articles and test systems should be both easy to manufacture and easy to use, preferably being producible at relatively low costs.

## **2. Description of the Background Art**

Assay devices which detect the presence of an analyte based on the enzymatic conversion of a substrate to a visible or detectable product within an absorptive matrix are described in U.S. Patent Nos. 5,059,525; 5,059,394; 4,256,693; 4,935,346; 3,791,933; and 3,663,374. Analytical apparatus having means for detecting sample application are described in U.S. Patent Nos. 5,049,487 and 4,420,566. The '487 patent describes a timing circuit which is triggered by detecting a change in reflectance caused by wetting of a porous matrix. The '566 patent describes the measurement of light absorbance to confirm that a liquid sample has been applied to a slide prior to analysis. Systems for controlling the

temperature of analytical test substrates are described in U.S. Patent Nos. 4,720,372; 4,219,529; and 4,038,030. Analytical test substrates comprising ion selective electrodes are described in U.S. Patent Nos. 4,171,246 and 4,053,381.

#### SUMMARY OF THE INVENTION

According to the present invention, apparatus and assays are provided for performing timed assays, particularly timed enzymatic assays under temperature control. The apparatus includes both a test article which receives a liquid sample being tested and a detection unit which receives the test article and optically determines a change in the test article resulting from presence of analyte in the sample over time. The observed change can thus be related to the presence (and usually amount) of analyte present in the sample. Such an apparatus permits performance of simplified assay protocols and formats where the application of sample to the test article present in the detection unit initiates a timing cycle and where the observed changes in the test article can then be detected as a function of time relative to the application of sample.

The test article comprises a bibulous matrix having one or more dried reagents present therein. The reagents are selected to produce a detectable signal in the presence of an analyte in a liquid sample applied to the matrix. A pair of spaced-apart electrodes are disposed on either side of a target location on the matrix so that application of a liquid sample to the target location will lower electrical resistance between the electrodes. In this way, initial sample application can be detected by monitoring the resistance across the electrodes, with a lowering of the resistance initiating a timing cycle in the detection unit. Additionally, a subsequent rise in electrical resistance between the electrodes may indicate that sample has evaporated or

otherwise been lost from the target location which can be a particular problem with relatively lengthy test protocols, particularly when employing small sample volumes.

5           The test article can further be designed to reduce evaporative loss of liquid sample. The spaced-apart electrodes will preferably be configured to leave only a narrow gap therebetween, and the remaining portions of the matrix surface(s) will be covered by  
10 other materials. Usually, at least a portion of the remaining covering will be transparent to permit optical assessment of the matrix of the test article during assay protocols as described in more detail hereinafter. With  
15 such a design, only the narrow gap between electrodes (which defines a target location for receiving sample) will remain uncovered, thus permitting liquid sample application but preventing significant evaporation from the bibulous matrix thereafter.

          A preferred construction for the test article  
20 of the present invention will comprise a relatively thin membrane defining the bibulous matrix, a pair of spaced-apart metal foil strips defining the electrodes and covering substantially the entire top surface of the membrane, and a transparent layer or support, such as a  
25 clear plastic strip, covering the bottom surface of the membrane. Such a test article permits sample application on the top of the membrane through the gap between adjacent electrodes and further permits optical viewing of the membrane through the transparent bottom.

30           The detection unit of the present invention will include a support stage for receiving the test article so that a reaction zone on the test article is disposed at a viewing location within the detection unit. The detection unit further includes means for measuring  
35 the electrical resistance across the test article when the test article is in place on the support stage. Usually, the resistance detecting means will include a

pair of plates or probes which contact the bibulous matrix on either side of the reaction zone (which is located at or near the target location), preferably comprising a pair of plates which contact the electrodes described above.

5

The detection unit, however, could be designed to function with test articles which do not include discrete electrodes. In particular, the detection unit could be designed to directly probe spaced-apart locations on the membrane surface. While such a design will generally be less preferred, it is considered to be within the broad scope of the present invention.

10

The detection unit will further comprise a heater for heating the test article approximate the reaction zone. In the exemplary embodiment, the heater will include heated plates which contact the metal foil electrodes on either side of the target location on the test article. The metal foil electrodes are thus able to transfer heat from the heated metal plates of the detection unit directly to the target location and reaction zone without blocking or obscuring the target zone for a sample application.

15

20

The detection unit still further includes optical viewing means for detecting an optical change in the reaction zone, typically through the transparent layer of the test article. In exemplary embodiments, the optical viewing means comprises a light source which directs light against the reaction zone and an optical detector which detects light emitted or reflected from the reaction zone.

25

30

According to the method of the present invention, a volume of a liquid sample is applied to the target location on a bibulous matrix, where the bibulous matrix comprises one or more dried reagents which in the presence of analyte initiate time-dependent production of a detectable signal. The precise time the sample is applied can be determined by measuring a change in

35



electrical resistance across the target location on the matrix. Production of the detectable signal is then measured at one or more times after the resistance change is first detected. In this way, the timed-dependant production of the detectable signal can be carefully monitored over time and accurately related back to the presence in amount of analyte in the liquid sample.

#### BRIEF DESCRIPTION OF THE DRAWINGS

Fig. 1 is an exploded drawing of an exemplary embodiment of a test article constructed in accordance with the principles of the present invention.

Fig. 2 is a schematic representation showing the test article in Fig. 1 present in a detection unit.

Fig. 3 is an exemplary graph showing the change in electrical and optical properties of a test article upon contact with analyte in a liquid sample.

Fig. 4 illustrates the test article and detection unit utilized in the examples of the Experimental section.

Fig. 5 is the result from an experiment using the test article and detection unit shown in Fig. 4. In this experiment, the results from 27 blood samples with varying prothrombin times were compared with prothrombin times obtained from a standard reference system.

#### DESCRIPTION OF SPECIFIC EMBODIMENTS

Assays according to the present invention are useful for detecting a wide variety of soluble analytes in virtually any type of biological or other sample which is liquid or which can be liquified. The methods and apparatus will find their greatest use with patient specimens, such as blood, serum, plasma, urine, cerebral fluid, spinal fluid, ocular lens liquid (tears), saliva, sputum, semen, cervical mucus, scrapings, swab samples, and the like, but might also find use with food, environmental, industrial, and other samples where substances can be detected using enzymatic, immunological, and similar techniques. The methods and

apparatus of the present invention are particularly useful for detecting analytes in very small liquid samples, typically having a volume in the range from about 3  $\mu$ l to 50  $\mu$ l, usually from 5  $\mu$ l to 30  $\mu$ l, but will also be suitable for use with much larger samples. In particular, the methods and apparatus of the present invention will be useful for analyzing very small blood samples, typically comprising a single drop of blood, employing non-skilled or semi-skilled personnel, frequently being self-administered.

The methods and apparatus of the present invention are also particularly suited for performing enzymatic assays within a bibulous matrix where an analyte in a sample applied to the matrix initiates, modulates, or otherwise affects the enzymatic conversion of a substrate (initially dried within the matrix) into an optically detectable product, such as a colored, luminescent, or fluorescent product. The present invention provides for very accurate timing of such enzymatic reactions based on initiation of a timing cycle at the moment the liquid sample is initially applied to the test article. The test article and detection unit can further provide for accurate temperature control of the test article, further assuring accuracy of the test result.

Assays according to the present invention provide for sensing of sample addition to a test article by measuring electrical resistance across a portion of the bibulous matrix to which the sample is applied. As the bibulous matrix and all reagents present therein are initially in a dry state, the resistance of the bibulous matrix prior to sample addition will be relatively high. Application of a liquid sample will immediately lower the electrical resistance across that portion of the matrix to which it is applied, thus providing a marker or trigger for initiation of a timing cycle. In the case of enzymatic reactions, build-up of the optically detectable

product will take some time and is usually highly dependent on the amount of analyte present within the sample (as well as other factors such as temperature). By providing control circuitry within or in combination with the detection unit, the amount of optically detectable product accumulating within the test article over time can be precisely determined. Based on one or more such data points, usually a plurality of such data points, the amount of analyte initially present in the sample can then be accurately calculated.

The detection unit of the present invention will comprise means for monitoring and measuring resistance across that portion of the test article to which liquid sample is to be applied. The resistance detecting circuitry will be connected to timing circuitry, which in turn will be connected to a suitable calculating means. Conveniently, the detection unit may include an interface for connecting to a digital controller, usually a microprocessor, which may be in the form of a general purpose personal computer. In this way, much of the timing and analytical function of the system of the present invention can be performed within the digital controller, with the specialized detection and sample conditioning functions being performed by the specialized apparatus of the present invention.

Referring now to Fig. 1, an exemplary test article 10 constructed in accordance with the principles of the present invention will be described. The test article 10 includes a bibulous matrix structure 12, typically in the form of a flat membrane; a support structure 14, typically in the form of a transparent strip; and an electrode structure 16, typically comprising a pair of spaced-apart electrodes 18 separated by a gap 20. The membrane 12, support structure 14, and electrode structure 16 will be laminated together, for example by adhesive layers 22 and 24, as illustrated. The adhesive layers 22 and 24 will include central

apertures 26 and 28 which permit viewing of the membrane 12 through the support structure 14 and application of sample to the membrane through the gap 20 in electrode structure 16. Preferably, the electrode structure 16 will include additional slots 30 formed in the electrodes 18, which slots define a target location for the application of liquid sample on the test article 10.

The bibulous matrix 12 will be composed of a material which can absorb liquid and which can contain, in dried form, the reagent(s) necessary for performing a desired assay. A wide variety of bibulous matrix materials might be used, including paper, methyl cellulose, porous polymers, and the like. The dimensions of bibulous matrix 12 should be such that at least a portion of the matrix can be saturated with liquid sample to both solubilize the necessary reagent(s) and to permit transport of the detectable reaction product to the lower side of the matrix so that it will be visible through the support structure 14.

In the preferred embodiment where small samples of blood are being analyzed, the bibulous matrix 12 will be a porous membrane structure composed of a hydrophilic (bibulous), non-swellable polymeric matrix material having pore dimensions which permit entry of blood plasma and proteins while excluding blood cells, particularly red blood cells (erythrocytes). The membrane should be composed of a single, continuous polymeric material with a foam-like structure consisting of a torturous network of channels having widths on the order of microns ( $\mu\text{m}$ ). The torturous network of channels is "densely packed" in that the "void volume" occupied by the empty space of the channels is an appreciable percentage of the total membrane volume, typically 10% or greater. Since all reaction chemistry, and subsequent signal generation, takes place in the void volume, a high void volume is desirable for producing a strong signal. A torturous network of channels is desired over straight and direct

pores, (such as the short, direct pores obtained with nucleopore membranes), as longer average channel lengths tend to produce an increasing isolation between the zone of the membrane where reaction chemistry is occurring, and the excess sample remaining on the surface of the membrane. This helps to render the system less sensitive to variations in applied sample volume.

In the specific case of blood coagulation assays, the porous membrane structure 12 will be impregnated with reagents necessary to induce coagulation in blood plasma which enters the interior of the porous matrix and to produce a detectable signal as an indication of the coagulation capability of the blood. It is particularly critical to the present invention that the polymeric matrix material of the porous membrane 12 be substantially free from interference with the coagulation pathway which is being induced. In particular, the polymeric matrix material should be free from surface effects, interactions, and artifacts which might induce coagulation or inactivate components such as enzymes, of the initiated pathway. Unintended initiation of a coagulation pathway could lead to false positive determinations while enzyme inactivation could lead to false negative determinations. It is therefore important that the polymeric matrix material have no promoting or diminishing effect on the coagulation reactions occurring within the membrane. Criteria can be for determining if a membrane is acceptable for use in coagulation testing are set forth in detail in copending application Serial No. 07/874,667, the full disclosure of which is incorporated herein by reference. A particularly preferred polymeric matrix material for performing blood coagulation assays is a 0.45  $\mu\text{m}$  asymmetric polysulfone membrane material available from Filterite-Memtec, 9690 Deeveco Road, Suite 7, Timonium, Maryland 21093, Catalog No. BTS-25.

The region of bibulous matrix 12 which is beneath the sample application target location slots 30 will be the reaction zone. It is in this region that the matrix 12 is first wetted and where the actual chemical reaction which results in production of a detectable reaction product occurs. When used with very small samples, as described above, the reaction zone will typically be relatively small, frequently being 1 cm in diameter or less, often being less than 0.5 cm. The remaining regions of the matrix 12 which are not wetted by the sample will not undergo a chemical reaction and will not accumulate visible reaction product.

Chemical reagents necessary for performing an assay according to the present invention will be impregnated within the bibulous matrix 12 and will be reconstituted by application of the liquid sample thereto. For the preferred enzymatic assays of the present invention, the reagents will include an enzyme substrate which is converted into an optically detectable product, typically a fluorescent, luminescent, or colored product, as a result of interaction with an enzyme. The enzyme may be the desired analyte or related to the analyte, or the enzyme may be added to the liquid sample and the production of detectable product by the enzyme modulated or otherwise affected by presence of analyte in the sample. The substrate may be a natural enzyme substrate which produces a natural detectable product, e.g. in the case of peroxidases, oxidases, hydrolases, and the like, or may be a synthetic substrate comprising a substrate group, such as a polysaccharide or peptide, which is cleavably linked to a reporter molecule, such as a chromogenic, chemiluminescent, or fluorogenic molecule. The presence or activity of the enzyme in the sample results in cleavage of the linker, causing a change in the optical characteristics of the reporter molecule. A variety of useful substrates are described in Haughland, *Molecular Probes Handbook of Fluorescent Probes in*

*Research Chemicals, Molecular Probes, Inc., Eugene, Oregon, the full disclosure of which is incorporated herein by reference.*

In the exemplary case of blood coagulation assays, necessary reagents include a coagulation initiator which initiates a preselected event or stage in either an extrinsic or intrinsic coagulation pathway and a substrate which is activated by a component which is produced in a subsequent stage of the coagulation pathway. A buffer will also be provided to maintain the test pH within a range compatible with the coagulation pathway, and optional reagents include flow control agents which decrease the chromatographic separation of the various test components as blood plasma enters the membrane, cofactors which sustain or enhance the chemical reactions of the coagulation pathway, stability enhancers, and pigments which enhance the optical characteristics of the test article. Typically, these reagents will be combined in one or more aqueous solution(s) which are applied to all or a portion of the polymeric matrix material. The matrix material may then be dried or lyophilized (and optionally mounted on the handle 14) to form a test article having the reagents non-covalently adsorbed therein. In some cases, it may be possible to covalently attach at least some of the reagents, although covalent attachment will usually not be necessary. Particular coagulation inhibitors, substrates, buffers, coagulation cofactors, and fluid control agents are set forth in application Serial No. 07/874,667, the full disclosure of which has previously been incorporated herein by reference.

The support structure 14 may take a variety of forms. The support structure 14 is intended primarily to act as a physical support for the remaining components of the test article 10 and should be optically transmissive, preferably being completely transparent at the light wavelengths of interest to the assay protocol. In a

preferred aspect of the present invention, the support structure 14 will also act as a moisture barrier in preventing loss of sample from the bibulous membrane 12. Suitable support structures 14 may be composed of  
5 transparent plastics, such as polystyrene, which is sufficiently thick and rigid to serve as a handle to permit manipulation of the test article 10 in the method steps of the present invention. Polystyrene strips  
10 having a length in the range from about 2 cm to 10 cm, a width in the range from about 0.5 cm to 2 cm, and a thickness in the range from about 0.1 mm to 0.5 mm have been found to be acceptable.

The electrode structure 16, is intended primarily to facilitate measurement of the electrical  
15 resistance across the reaction zone of bibulous matrix 12. It will be appreciated that the methods of the present invention could utilize electrical resistance probes which contact the bibulous matrix directly, that is without the need for providing intermediate contacting  
20 electrodes. The preferred test article 10 of the present invention, however, provides a suitable electrode structure in order to facilitate electrical resistance measurement using the detection unit, as described in more detail hereinafter.

25 The electrode structure 16 preferably also serves as a cover for the bibulous matrix 12 to inhibit evaporative and other losses of sample fluid therefrom. Thus, the electrode structure 16 will generally cover a majority of the exposed surface of the bibulous matrix  
30 12, typically leaving only the small gap 20 and slots 30 therebetween.

Conveniently, both electrode halves 18 of the electrode structure 16 will be composed entirely of a  
35 conductive material, usually a metal foil. Use of the metal foil also acts to enhance heat transfer to the reaction zone of bibulous matrix 12, as described in more detail in connection with the detection unit hereinafter.



It will be appreciated, however, that the individual electrodes 18 need not be composed entirely of electrically conductive material, and in fact only need to define a discrete conductive path from the bibulous matrix 12 to a location which can be probed or connected by the detection unit.

It should be further appreciated that the test articles of the present invention are not limited to structures having the electrode 16 and support structure 14 sandwiched about a bibulous matrix 12. Test articles according to the present invention require only that a pair of spaced-apart electrodes be provided on either side of a sample target location on the bibulous matrix, where the electrodes facilitate interconnection with an electrical resistance measuring mechanism, such as that provided by the detection unit of the present invention.

The adhesive layers 22, 24 may be composed of any suitable material, typically being double sided tape, such as that available from 3M Corporation, Minneapolis, Minnesota.

Referring now to Fig. 2, a detection unit 32 is schematically illustrated. The detection unit 32 includes plates 34 which contact the electrodes 18 of the test article 10 when the test article has been inserted into the detection unit. The contact plates 34 act as probes in measuring electrical resistance across the reaction zone in matrix 12 beneath the target location slots 30. Plates 34 will be connected to conventional electrical resistance monitoring circuitry in order to provide an output suitable for a digital control unit (not illustrated) or microprocessor.

In a preferred aspect of the present invention, plates 34 will be heated, typically by conventional electrical resistance heaters. For example, the plates 34 may have heating coils on the surface thereof or embedded therein. The heating coils, in turn, could be connected to a conventional power supply 35, with heat

being controlled by conventional control circuitry or by a separate computer or other digital controller. Heat provided by plates 34 will be transferred by metallic electrode plates 18 to the matrix 12 to an area at least partially overlapping with the reaction zone.

Detection unit 32 further includes a system 40 for optically viewing the reaction zone when the test article 10 is in place within the unit. This optical system may monitor reflectance, fluorescence, or luminescence. In this example, a fluorescence system 40 is illustrated. This fluorescence system 40, as illustrated, includes a light source 42 and a notch filter 44 which together provide a light beam 46 which falls on the reaction zone of test article 10 through the transparent support structure 14. Reflected or emitted light 48 passes through a second notch filter 50, with filtered light being detected by photodetector 52. In the exemplary case of blood coagulation assays, detection will usually be based on fluorescence, where the light beam 46 is provided at an excitation wavelength and the light beam 48 is emitted at a known emission wavelength.

In summary, an assay according to the present invention may be performed by applying a liquid sample through the target location 30 on the electrode structure 16 of the test article 10. The liquid sample will flow through the gap 20 and other slots in the target location into a reaction zone within bibulous matrix 12. The presence of analyte in the sample will affect or modulate the production of a detectable reaction product within the matrix 12, eventually providing an optically detectable change on the lower surface of the matrix. The production of optically active reaction products may be observed by directing a light beam 46 through the transparent support 14 onto the reaction zone of membrane 12. The fluorescent material at present, will emit light at a fluorescent wavelength which is eventually detected by a photodetector 52. The amount of

signal produced over time will depend on the amount of analyte present in the sample.

Fig. 3 illustrates the changes in resistance and optical characteristics that typically take place during the course of an assay. Before the application of a fluid sample, the resistance across the electrode gap is extremely high. By contrast, the optical signal (here shown as fluorescence) is low. Upon application of sample at time zero, there is an immediate drop in resistance. By contrast, there is no corresponding change in the optical signal until appreciable amounts of the enzyme substrate have been converted to detectable product within the reaction membrane. As time continues, the resistance across the electrode junction on the reagent strip may increase, due to drying of the strip. As previously discussed, the system may choose to reject a particular sample as being insufficiently moist if the resistance measurement becomes too high.

The following examples are offered by way of illustration, not by way of limitation.

### EXPERIMENTAL

#### General Methodology

##### Instrument:

Observations were performed using a prototype instrument. The instrument optics included a Siemens BPW-34B photodetector mounted below a 550 nanometer filter with a 25 nanometer bandwidth (S25-550-A, Corion Corporation, Holliston, MA). The specimens were illuminated by a Mini-Maglite™ LM3A001 light bulb (Mag Instrument Inc., Ontario, CA) with output filtered through a 500 nanometer filter with a 25 nanometer bandwidth (Corion Corporation, S25-500-A). The output from the photodetector was amplified by an instrumentation amplifier (described on page 89 of the IC Users Casebook, 1988, by Joseph Car, Howard Samms & Company), digitized by a 12 bit analog to digital converter, and recorded on an IBM compatible personal

computer. Temperature control was achieved by placing reagent strip 10 in a heated reagent stage 50, as shown in Fig. 4. The stage 50 included an upper heater and a lower heater with test strip 10 in the middle. A slot 52 was provided into the upper stage to facilitate insertion and removal of the strip 10 into the stage, and to provide easy sample access from the top. The stage was heated by eight, 200 ohm 1/4 watt resistors connected in parallel. For the lower heater, four resistors were mounted on a thin circuit board 54 and were used to heat a 0.015" thick aluminum plate 56, with a 0.5" diameter hole 58 as an optics aperture. For the upper heater, four resistors were mounted on a circuit board 60 and used to heat two separate, and electrically isolated, 0.015" thick aluminum plates 62. Circuit board 60 additionally had a 0.45" by 1.5" opening 52 in it to allow easy application of sample to the reagent strip's aperture 30.

As shown in both Fig. 2 and Fig. 4, aluminum plates 62 on the stage's upper heater made a tight contact with the opposite sides of the test strip's foil surface electrodes. The stage's relatively thick aluminum plates acted to evenly distribute the heat emanating from the resistors, and helped insure good heat flow to the test strip's foil surface. The tight contact between the meter's aluminum plates, and the test strip's foil electrodes, was also used to form an electrical circuit that was used to detect the state of the strip's fluid detection sensor.

The temperature was regulated by monitoring the stage via an Acculex RTDR-2 temperature sensitive resistor (Keithley Metrabyte Instruments Corp., Taunton MA). The electronics used to construct the fluid sensor and the temperature sensor are standard resistance monitoring circuits described on pages 55 and 62 of the Dascon-1 Manual, copyright 1983, by Metrabyte Corporation, Taunton, MA. Unless otherwise noted,

temperatures were maintained at 37°C by a feedback control program monitored by an IBM compatible personal computer. The computer system controlled a switching circuit that energized the heater, using a 6 volt power source, whenever temperatures dropped below 37°C. In use, reagent strips were allowed to pre-equilibrate to 37°C for a minimum of 60 seconds before sample was applied.

10 Preparation of Boc-Val-Pro-Arg-Rhodamine 110:

Five grams of Boc-Val-Pro-OH (catalog A-2480) were purchased from Bachem Bioscience, Inc., Philadelphia PA. This was conjugated onto (CBZ-Arg)<sub>2</sub>-Rhodamine-110 to produce (Boc-Val-Pro-Arg)<sub>2</sub>-Rhodamine 110 following the methods of Mangel, et. al. in U.S. Patent 4,557,862 and U.S. Patent 4,640,893. This formed the enzyme substrate used to detect thrombin production in the exemplary prothrombin time assay disclosed here.

20 Preparation of photo-etched electrode apertures:

A etching pattern was prepared, consisting of a repeated series of the following configuration: one 0.625" long, 0.015" wide electrode gap, as shown as 20 on Fig. 1, and two 0.185" long, 0.007 wide fluid apertures shown as 30 on Fig. 1, arranged in a cross configuration on the center of the electrode gap, with each slit separated by an angle of 60° from the other slits. This pattern was etched onto 1 mil thick aluminum foil by Accutech, Inc., San Fernando, CA using conventional photo-etching techniques. The apertures were trimmed to a square 0.500" x 0.500" configuration, with the aperture centered in the middle of this square.

35 Preparation of coated membrane:

Coated membranes were prepared generally as described in copending application Serial No. 07/874,667.

In a 20 ml vial, using a small magnetic stirrer, the following were combined:

6 ml 0.2 M HEPES pH 7.4;

2 ml H<sub>2</sub>O;

5 1 ml 100 mM CaCl<sub>2</sub>; and

500 mg Sigma poly vinyl alcohol P-8136;

and were stirred for about 2 hours until the PVA had totally dissolved.

10 One gram of Sigma protease-free bovine serum albumin A-3292 was added, and the mixture was allowed to stir for about 20 minutes until it had totally dissolved. A solution of 4.5x concentrated Dade-C thromboplastin (Baxter B4216-20, Baxter Healthcare Corporation, Miami, FL), was prepared by adding 880  $\mu$ l H<sub>2</sub>O to nominal 4ml  
15 containers of thromboplastin. One ml of the concentrated (4.5x) Dade-C thromboplastin was added to the dip and was stirred for 10 minutes. One ml of a concentrated (4mg/ml) solution of fluorescent thrombin substrate dissolved in 50% isopropanol, 50% H<sub>2</sub>O was then added, and  
20 the resulting mixture stirred for 10 minutes.

#### Membrane dip:

The large pore side (dull side) of a BTS-25 0.45  $\mu$ m asymmetric polysulfone membrane (Memtec/Filterite Corporation, Timonium MD) was rapidly coated with fresh  
25 dip, and the excess dip was gently squeegeed off. The coated membrane was immediately dried in a mechanical convection oven at 50°C for 15 minutes. The membrane was then stored with desiccant under cool (4°C) conditions  
30 until use.

#### Preparation of membrane strips:

The reagent's support layer 14, Fig. 1, was composed of 10 mil thick transparent styrene. The  
35 various layers were held together by 0.5" wide 3M 415 double sided adhesive tape, made by the 3M Corporation. To hand-assemble the strips, two preliminary assemblies

were first created. The first assembly consisted of a series of 0.25" diameter holes spaced 0.500" apart, pre-punched in the double sided adhesive tape. This adhesive tape 24, Fig. 1, was then applied to a length of foil containing a series of repeating apertures, each 0.500" apart. Excess foil, used to keep the repeating aperture structures intact in the absence of the adhesive tape, was then trimmed away, producing an "aperture tape" assembly with adhesive on one side, and a repeating series of electrode apertures on the other side. This was kept flat to keep the delicate electrode aperture structures intact.

A second preliminary assembly was created consisting of a strip of transparent styrene laminated with 3M 415 tape and a length of 0.5" wide treated reaction membrane. To avoid migration of adhesive into the reaction membrane, and it's possible deleterious effects on storage, a series of 0.25" holes were punched every 0.500" in the sections of the tape that were immediately below the "reaction zone" on the final strip 22, Fig. 1. Thus the coated membrane in the reaction zone did not come into immediate contact with any materials except the metallic foil aperture covering. The two preliminary assemblies were then aligned with the aid of a light box, and laminated together. The repeating subunits on the final assembly were then cut into individual strips for testing.

This reagent, and the meter described previously, were then used to perform the following experiments.

#### Experiment 1:

Resistance drop upon addition of biological fluids: Reagent strips were prepared according to the above methods. The resistance across the strips was monitored as a function of time. Before addition of blood, the resistance across the electrode junction was

effectively infinite (>100 mega ohms). Upon addition of blood, the resistance immediately dropped to about 30 kilo ohms.

5 Experiment 2:

Detection of insufficient sample by resistance readings. Reagent strips prepared according to above methods were each given 1.0, 2.0, 3.0, and 4.0  $\mu$ l of whole blood. After six minutes of reaction time, the  
10 respective resistance measurements of the various strips were:

	<u>Sample Size</u>	<u>Resistance</u>
15	1.0 $\mu$ l	2.5 mega ohms
	2.0 $\mu$ l	400K kilo ohms
	3.0 $\mu$ l	60K kilo ohms
	4.0 $\mu$ l	40K kilo ohms

20 Insufficient sample thus could be detected by a substantial increase in resistance.

Experiment 3:

Effect of metal foil on reaction kinetics at  
25 low humidity: Strips were prepared omitting the metallic foil, and studied with Sigma coagulation control I, II and III plasma in a low ambient humidity environment and manual initiation of test timing. In the absence of the surface covering, lower fluorescence intensity developed,  
30 and the reaction kinetics for level II and level III (prolonged and very prolonged PT time controls) was significantly prolonged.

Experiment 4:

35 Effect of a hole in the transparent reagent support on reaction kinetics at low humidity: Strips were prepared containing the metallic foil, but



5 additionally with a 0.25" diameter hole placed in the transparent support immediately below the reaction zone on the membrane. These were studied with coagulation control I, II and III plasma (C-7916, C-8916 and C-9916, Sigma Chemical Company, St. Louis, MO) in a low ambient humidity environment. In the absence of the surface covering, lower fluorescence intensity developed, and the reaction kinetics for level II and level III (prolonged and very prolonged PT time controls) was significantly  
10 prolonged.

#### Experiment 5:

Effect of metallic foil cover on temperature equilibration of reagent: Before they are applied to the meter, the test samples may be at a variety of different  
15 initial temperatures (typically 15-30°C). To give accurate results, the test article must equilibrate these different samples to the same reaction temperature (typically 37°C) as rapidly as possible. This experiment measured the relative effectiveness of a metallic foil cover, versus a non-metallic plastic cover, at rapidly  
20 equilibrating different samples.

In this experiment, a series of test articles were made up with either 1 mil thick aluminum covers, or  
25 5 mil thick transparent styrene covers. These were placed into a meter stage and equilibrated to 37°C. 10 µl drops of water (at 4°C) were then applied, and the temperatures monitored by a non-contact infrared thermometer (C-1600 meter, Linear Laboratories Company, Fremont, CA). Both the aluminum foil and the transparent  
30 styrene were painted flat black (Model 2529 marker, Testor Corp., Rockford IL), to provide equivalent conditions for the infrared beam. The resulting temperatures were:

35

	<u>Time after application</u> <u>(sec.)</u>	<u>Foil temp.</u>	<u>Plastic temp.</u>
	1	33	20
5	5	35	23
	10	37	26
	15	37	28
	30	37	33
10	45	37	37

The results show that the foil covering equilibrated the sample to the desired temperature more quickly than did the plastic covering.

15

Experiment 6:

Performing fluorescence assays without a meter hatch: In the following experiment, the meter was programmed to take fluorescence measurements by turning its light source on briefly every 15 seconds, and recording the fluorescence value. Immediately before the meter's own light source was turned on, however, the meter also recorded a "background" value. This background value was then subtracted from each fluorescence measurement.

25

It was found that when a non-light transmissive covering with a narrow slit was used, such as the metal foil arrangement discussed previously, the system was remarkably insensitive to the presence or absence of external light - e.g. normal room lighting, or indirect sunlight. This is attributed to a combination of factors, including the great attenuation of ambient light by the metal foil covering on the strip, the high fluorescence efficiency and amounts of the Rhodamine 110 fluorophore used in this experiment, and the background subtracting algorithm used here.

35

Experiment 7:

Clinical study: Venous blood from 27 patients, including 20 patients being treated with Coumadin, was drawn and stored in citrate. 10 µl samples of whole

40

blood from each patient were then run on the device as described above. Fluorescence measurements were taken every 15 seconds for six minutes. The time required for the fluorescence intensity to reach half maximum (T50%) was plotted versus the reference prothrombin times as determined on a MLA Electra 750 coagulation meter. A regression analysis was done using Microsoft Excel 4.0 software.

5  
10  
A best fit polynomial to relate the T50% levels to the reference instrument was found to be prothrombin time (corrected) =  $1.93 + 0.079 * T50\%$ . The correlation coefficient ( $R^2$ ) was 0.92. The results from this experiment are shown in Fig. 5. The results show that this configuration can give good clinical results.

15  
20  
Although the foregoing invention has been described in some detail by way of illustration and example, for purposes of clarity of understanding, it will be obvious that certain changes and modifications may be practiced within the scope of the appended claims.

WHAT IS CLAIMED IS:

1. An assay for determining an analyte in a liquid sample, said assay comprising:
  - 5 applying a volume of the sample to a target location on a bibulous matrix, wherein the matrix comprises one or more dried reagents which in the presence of analyte initiate time-dependent production of a detectable signal;
  - 10 measuring a change in electrical resistance across the target location which results from the application of liquid sample; and
  - 15 detecting the production of signal within the matrix at one or more times after the change in resistance was first measured.
2. An assay as in claim 1 wherein the sample volume is from 3  $\mu$ l to 50  $\mu$ l.
- 20 3. An assay as in claim 1, wherein the sample is a patient sample.
4. An assay as in claim 3, wherein the patient sample is blood.
- 25 5. An assay as in claim 1, wherein the analyte is an enzyme and the reagents include an enzyme substrate which produces an optically detectable change after exposure to the enzyme.
- 30 6. An assay as in claim 5 wherein the optically detectable change is fluorescence, luminescence, or color change.
- 35 7. An assay as in claim 1, wherein the analyte is a component of the coagulation pathway and the

substrate produces the detectable signal upon activation by said component.

5 8. An assay as in claim 1, further comprising controlling the temperature of the bibulous matrix to 37°C.

10 9. An assay as in claim 1, further comprising monitoring the electrical resistance across the target location, whereby loss of liquid sample can be detected.

15 10. An assay as in claim 1, wherein the production of signal is detected at a plurality of time points over a preselected time duration.

20 11. An improved enzyme assay of the type wherein a liquid sample suspected of containing the enzyme is applied to a bibulous matrix-containing reagents which result in production of an optically detectable signal over time, wherein the improvement comprises measuring a change in electrical resistance within the matrix resulting from application of the liquid sample and detecting the production of signal at one or more times after the electrical resistance change is first measured.

30 12. An improved assay as in claim 11, wherein electrical resistance is measured by contacting a pair of electrodes which are secured to the bibulous matrix on either side of the spot where liquid sample is applied.

35 13. An improved assay as in claim 11, wherein the electrical resistance is continuously monitored to assure that the liquid sample has not been lost during the assay procedure.

14. An improved assay as in claim 11, wherein the production of signal is detected at a plurality of time points over a preselected time duration which commences when the change in electrical resistance is first detected.

15. A test article comprising:  
a bibulous matrix;  
one or more dried reagents which are present within the matrix and which, when wetted by a liquid sample, initiate an optically detectable chemical reaction with an analyte present in the sample; and  
a pair of spaced-apart electrodes proximate a sample target location of the matrix, wherein the electrodes are disposed so that application of the liquid sample to the target location will lower electrical resistance between the electrodes.

16. A test article as in claim 15, wherein the spaced-apart electrodes are secured to the bibulous matrix and in electrical contact with at least a portion of a surface of the matrix on opposite sides of the target location.

17. A test article as in claim 16, where the electrodes are metal foil strips which are attached to the matrix surface by an adhesive.

18. A test article as in claim 15, wherein the gap between the spaced-apart electrodes has a width in the range from 0.1 mm to 2 mm, whereby the electrode inhibits evaporation of sample from the matrix.

19. A test article as in claim 18, further comprising a transparent support element attached to a surface of the membrane opposite to the electrodes.

20. A test article as in claim 15, wherein the bibulous matrix is composed of a hydrophilic, non-swelling material which is free from interference with the coagulation pathway.

5

21. A test article as in claim 20, wherein the reagents comprise a coagulation initiator and a substrate which produces a detectable signal upon activation by a component of the coagulation pathway.

10

22. A test article as in claim 21, wherein the coagulation pathway component is thrombin and the substrate is a peptide cleavably bound to a reporter molecule, wherein thrombin binds the peptide and cleaves the reporter molecule to produce the detectable signal.

15

23. A test article as in claim 22, wherein the detectable signal is fluorescence.

20

24. A test article comprising:

a bibulous matrix;

one or more dried reagents which are dispersed within the substrate and which, when wetted by a liquid sample, initiate an optically detectable enzymatic reaction with an enzyme analyte present in the sample; and

25

a pair of spaced-apart metal strips attached to a surface of the matrix to define a sample target location therebetween, whereby application of the liquid sample to the target location will lower electrical resistance between the metal strips.

30

25. A test article as in claim 24, where the metal foil strips are attached to the matrix surface by an adhesive.

35

26. A test article as in claim 24, wherein the gap between the spaced-apart metal foil strips has a width in the range from 0.1 mm to 2 mm, whereby the strips inhibit evaporation of sample from the matrix.

5

27. A test article as in claim 26, further comprising a transparent support element attached to a surface of the membrane opposite to the metal foil strips.

10

28. A test article as in claim 24, wherein the bibulous matrix is composed of a hydrophilic, non-swelling material which is free from interference with the coagulation pathway.

15

29. A test article as in claim 28, wherein the reagents comprise a coagulation initiator and a substrate which produces a detectable signal upon activation by a component of the coagulation pathway.

20

30. A test article as in claim 29, wherein the coagulation pathway component is thrombin and the substrate is a peptide cleavably bound to a reporter molecule, wherein thrombin binds the peptide and cleaves the reporter molecule to produce the detectable signal.

25

31. A test article as in claim 30, wherein the detectable signal is fluorescence.

30

32. A detection unit comprising:

a support stage for receiving a test article, wherein a reaction zone on the test article is disposed at a viewing location;

a heater attached to the support stage for heating the test article in the region of the reaction zone.

35



means attached to the support stage for detecting electrical resistance across the test article; and

5 means attached to the support stage for optically viewing the reaction zone when disposed at the viewing location.

10 33. A detection unit as in claim 32, further comprising an input/output interface for connecting at least one of the heater, electrical resistance detection means, and the optical viewing means to a digital controller.

15 34. A detection unit as in claim 32, wherein the heater comprises an upper heated surface and a lower heated surface, which surfaces are disposed to contact a top and a bottom side of the test article around the reaction zone.

20 35. A detection unit as in claim 32, wherein the electrical resistance detecting means includes a pair of spaced-apart plates which contact the test article on opposite sides of the reaction zone when the test article is in place in the support stage.

25 36. A detection unit as in claim 32, wherein the optically viewing means comprises a light source which directs light at the reaction zone and a light detector which detects light from the reaction zone.

30 37. A detection unit as in claim 36, wherein the light source emits light at a wavelength selected to induce fluorescence in a particular reaction product and the light detector detects light at the fluorescent  
35 wavelength.

38. A detection unit for use in combination with a test article comprising:

(a) a bibulous matrix;

(b) one or more dried reagents which are present within the matrix and which, when wetted by a liquid sample, initiate an optically detectable chemical reaction with an analyte present in the sample;

(c) a pair of spaced-apart metal strips proximate a sample target location of the matrix, wherein the electrodes are disposed so that application of the liquid sample to the target location will lower electrical resistance between the electrodes.

wherein the detection unit comprises:

a support stage for receiving the test article, wherein a reaction zone on the test article is disposed at a viewing location;

a heater attached to the support stage for heating the test article in the region of the reaction zone.

means attached to the support stage for detecting electrical resistance across the test article; and

means attached to the support stage for optically viewing the reaction zone when disposed at the viewing location.

39. A detection unit as in claim 38, further comprising an input/output interface for connecting at least one of the heater, electrical resistance detection means, and the optical viewing means to a digital controller.

40. A detection unit as in claim 38, wherein the heater comprises a pair of metal plates and means for heating said plates, wherein said plates contact the metal strips on the test article and said metal strips conduct heat to the reaction zone.

41. A detection unit as in claim 38, the electrical resistance detecting means includes the same metal plates which comprise the heater, whereby electrical resistance is measured across the gap between the metal strips on the test article.

5

42. A detection unit as in claim 38, wherein the optically viewing means comprises a light source which directs light at the reaction zone and a light detector which detects light from the reaction zone.

10

43. A detection unit as in claim 42, wherein the light source emits light at a wavelength selected to induce fluorescence in a particular reaction product and the light detector detects light at the fluorescent wavelength.

15

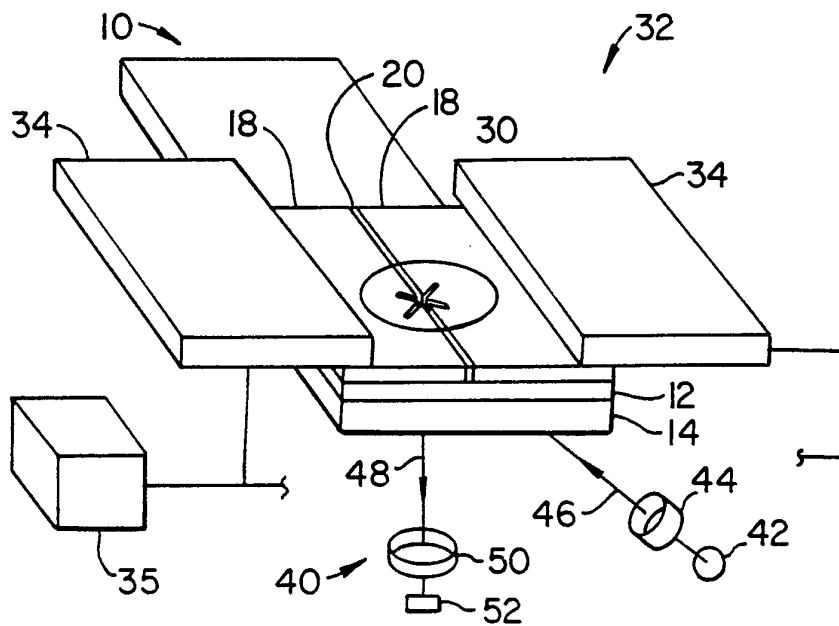
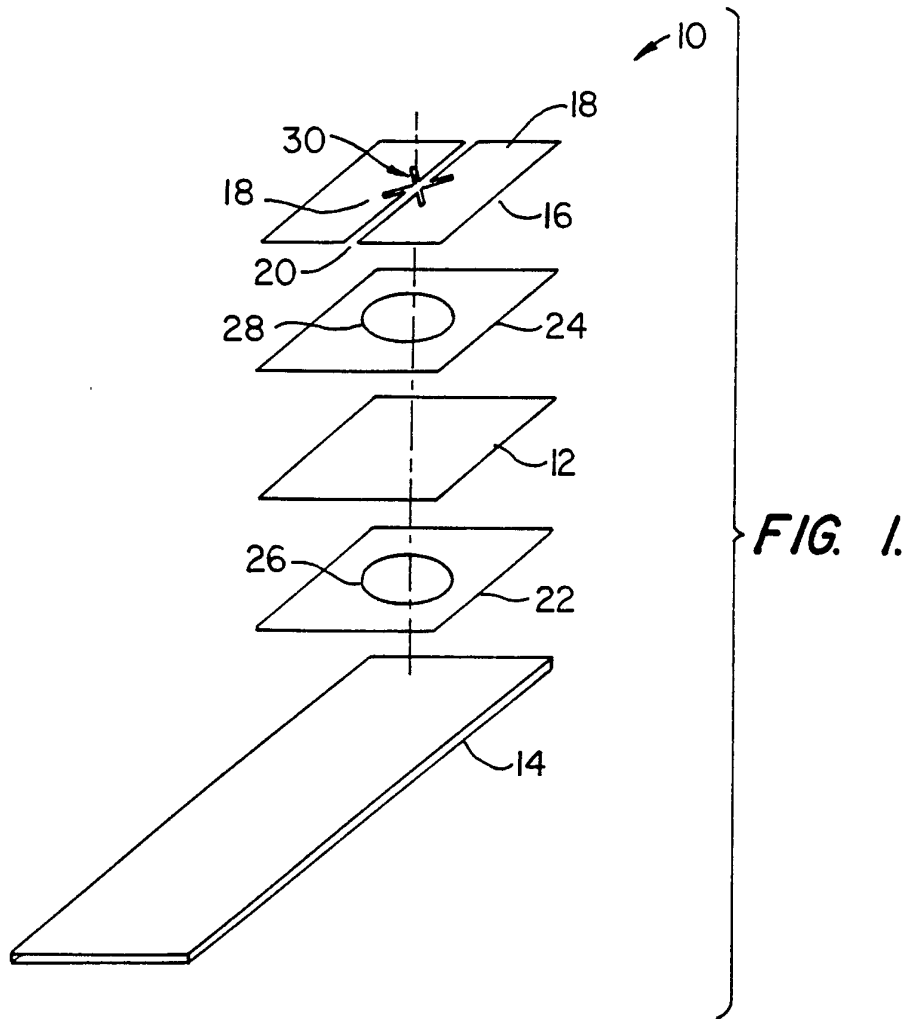

FIG. 2.

SUBSTITUTE SHEET (RULE 26)

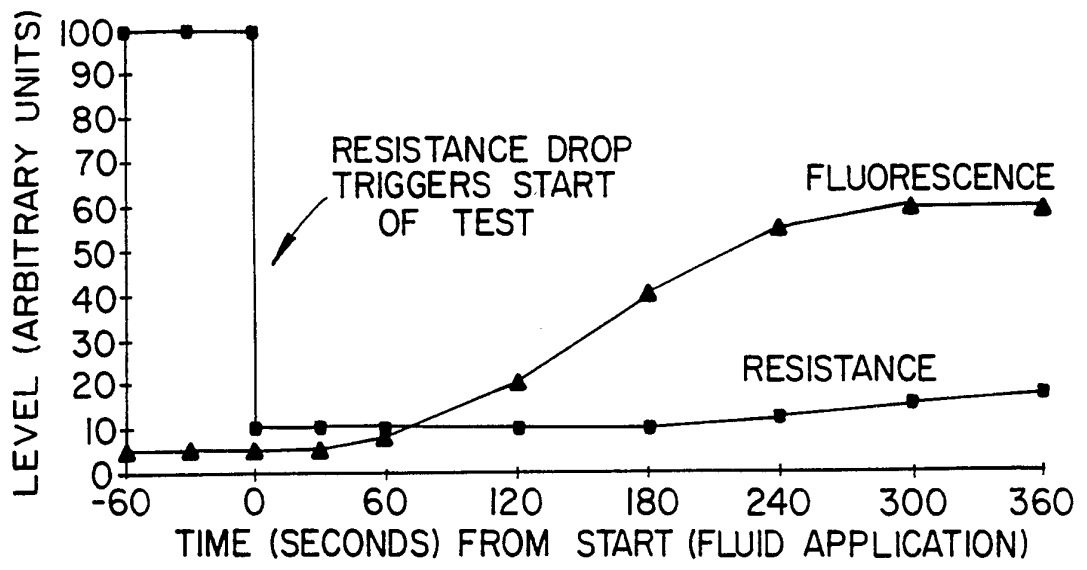

FIG. 3.

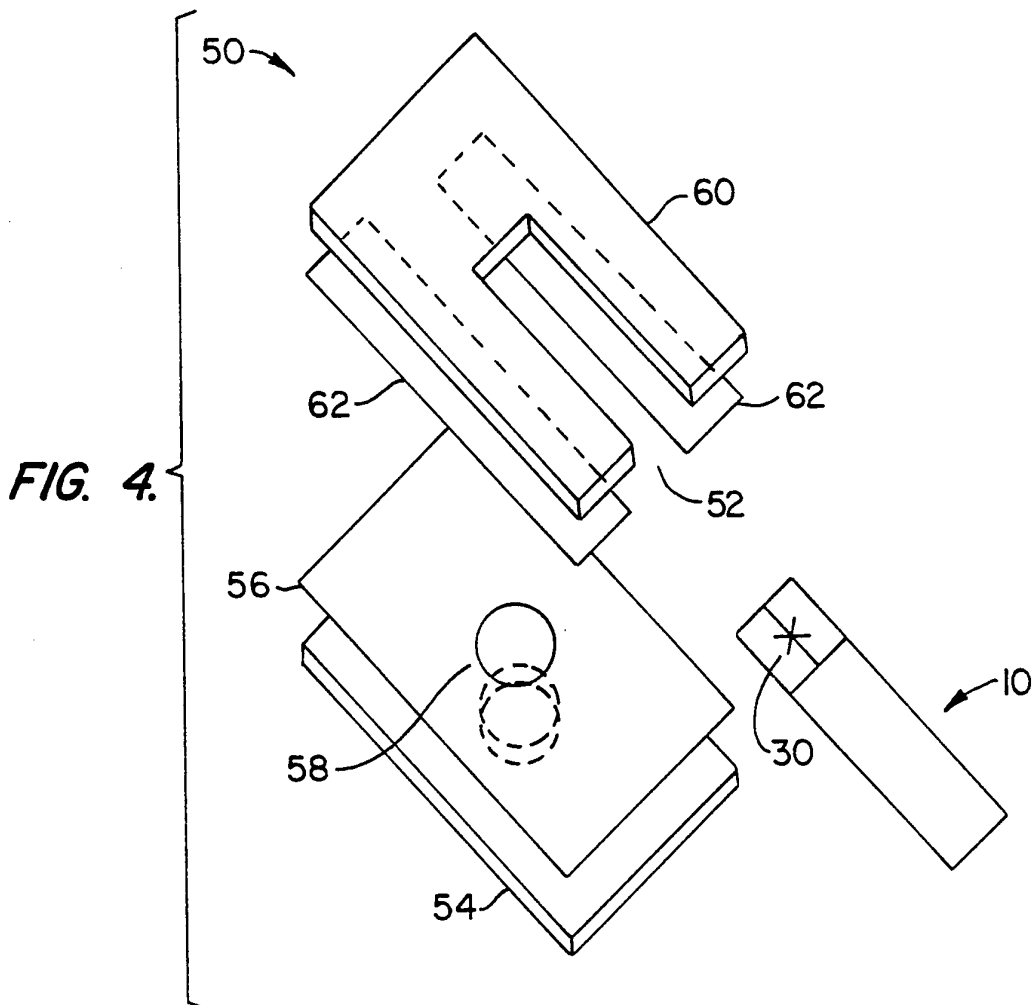
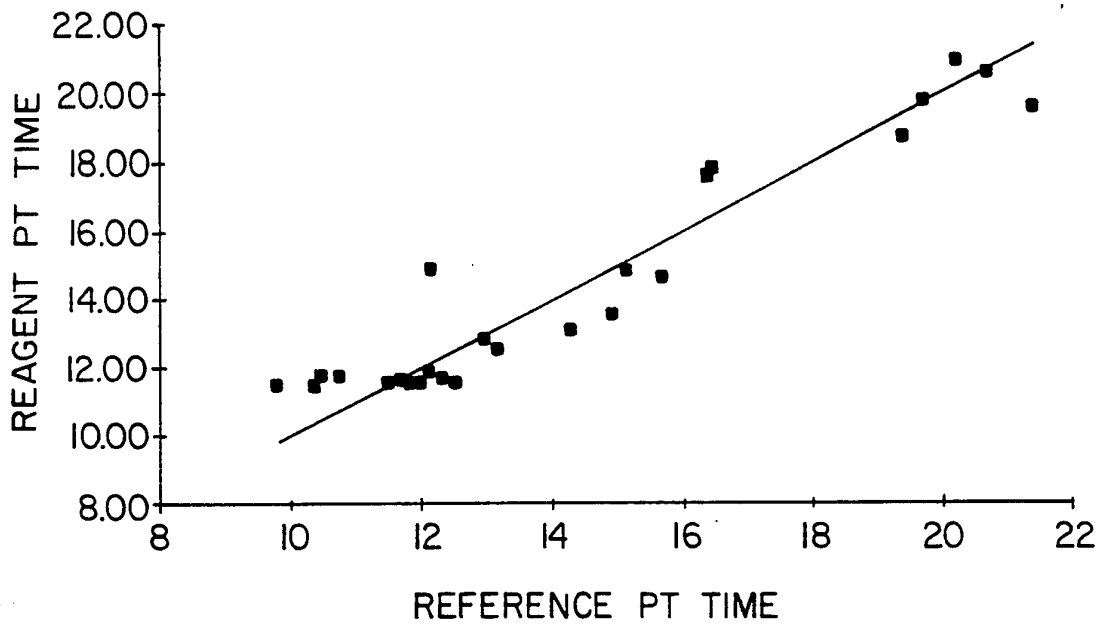

FIG. 4.



*FIG. 5.*

# INTERNATIONAL SEARCH REPORT

International application No.  
PCT/US94/00393

**A. CLASSIFICATION OF SUBJECT MATTER**

IPC(5) : C12Q 1/00; G01N 35/00, 21/00  
 US CL : 435/4, 817; 436/46, 805, 806, 808; 422/56; 204/153.12  
 According to International Patent Classification (IPC) or to both national classification and IPC

**B. FIELDS SEARCHED**

Minimum documentation searched (classification system followed by classification symbols)

U.S. : 435/4, 817; 436/46, 805, 806, 808; 422/56; 204/153.12;

Documentation searched other than minimum documentation to the extent that such documents are included in the fields searched

Electronic data base consulted during the international search (name of data base and, where practicable, search terms used)

APS, Chemistry Abstracts, BIOSIS, MEDLINE, EMBASE

**C. DOCUMENTS CONSIDERED TO BE RELEVANT**

Category*	Citation of document, with indication, where appropriate, of the relevant passages	Relevant to claim No.
A	US, A, 3,826,734 (Godsey) 30 July 1974, see entire document.	1-31
A	US, A, 4,171,246 (Hamblen et al.) 16 October 1979, see columns 2, 3, and 10.	1-31
A	US, A, 4,366,241 (Tom et al.) 28 December 1982, see entire document.	1-31
A	US, A, 4,911,794 (Parce et al.) 27 March 1990, see entire document.	1-31
A	UK, A, 1,318,815 (Miles Laboratories) 31 May 1973, see pages 1, 2 and 4.	1-31

Further documents are listed in the continuation of Box C.  See patent family annex.

<p>* Special categories of cited documents:</p> <p>*A* document defining the general state of the art which is not considered to be part of particular relevance</p> <p>*E* earlier document published on or after the international filing date</p> <p>*L* document which may throw doubts on priority claim(s) or which is cited to establish the publication date of another citation or other special reason (as specified)</p> <p>*O* document referring to an oral disclosure, use, exhibition or other means</p> <p>*P* document published prior to the international filing date but later than the priority date claimed</p>	<p>*T* later document published after the international filing date or priority date and not in conflict with the application but cited to understand the principle or theory underlying the invention</p> <p>*X* document of particular relevance; the claimed invention cannot be considered novel or cannot be considered to involve an inventive step when the document is taken alone</p> <p>*Y* document of particular relevance; the claimed invention cannot be considered to involve an inventive step when the document is combined with one or more other such documents, such combination being obvious to a person skilled in the art</p> <p>*&amp;* document member of the same patent family</p>
---	---

Date of the actual completion of the international search

28 February 1994

Date of mailing of the international search report

APR 13 1994

Name and mailing address of the ISA/US  
 Commissioner of Patents and Trademarks  
 Box PCT  
 Washington, D.C. 20231

Facsimile No. NOT APPLICABLE

Authorized officer

RALPH GITOMER *Jill Warden for*

Telephone No. (703) 308-0196

# INTERNATIONAL SEARCH REPORT

International application No.  
PCT/US94/00393

## Box I Observations where certain claims were found unsearchable (Continuation of item 1 of first sheet)

This international report has not been established in respect of certain claims under Article 17(2)(a) for the following reasons:

1.  Claims Nos.:  
because they relate to subject matter not required to be searched by this Authority, namely:
  
2.  Claims Nos.:  
because they relate to parts of the international application that do not comply with the prescribed requirements to such an extent that no meaningful international search can be carried out, specifically:
  
3.  Claims Nos.:  
because they are dependent claims and are not drafted in accordance with the second and third sentences of Rule 6.4(a).

## Box II Observations where unity of invention is lacking (Continuation of item 2 of first sheet)

This International Searching Authority found multiple inventions in this international application, as follows:

- I. Claims 1-31, drawn to an assay and test strip, Class 435, subclass 4.
- II. Claims 32-43, drawn to a detection apparatus, classified in Class 435, subclass various.

1.  As all required additional search fees were timely paid by the applicant, this international search report covers all searchable claims.
2.  As all searchable claims could be searched without effort justifying an additional fee, this Authority did not invite payment of any additional fee.
3.  As only some of the required additional search fees were timely paid by the applicant, this international search report covers only those claims for which fees were paid, specifically claims Nos.:
  
4.  No required additional search fees were timely paid by the applicant. Consequently, this international search report is restricted to the invention first mentioned in the claims; it is covered by claims Nos.:  
1-31

### Remark on Protest

- The additional search fees were accompanied by the applicant's protest.  
 No protest accompanied the payment of additional search fees.



# INTERNATIONAL SEARCH REPORT

International application No.  
PCT/US94/00393

## C (Continuation). DOCUMENTS CONSIDERED TO BE RELEVANT

Category*	Citation of document, with indication, where appropriate, of the relevant passages	Relevant to claim No.
A	Analytica Chimica Acta, Volume 229, No. 1, issued 01 February 1990, N. C. Foulds, "Rapid Electrochemical Assay for Theophylline in Whole Blood Based on the Inhibition of Bovine Liver Alkaline Phosphatase", pages 57-62, see abstract and page 59, column 1 second paragraph.	1-31