

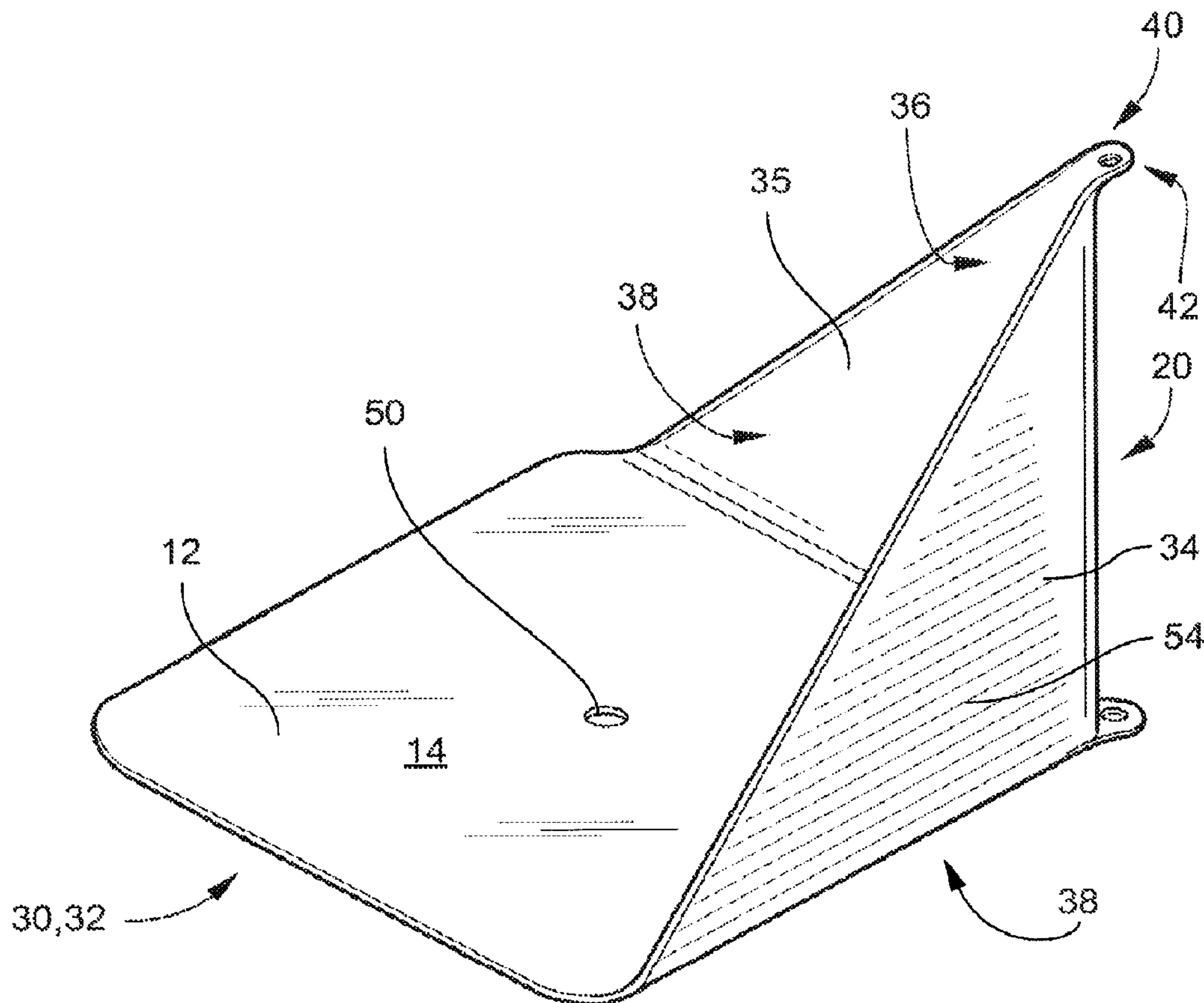

(22) **Date de dépôt/Filing Date:** 2014/01/16
 (41) **Mise à la disp. pub./Open to Public Insp.:** 2015/06/05
 (45) **Date de délivrance/Issue Date:** 2016/05/10
 (30) **Priorité/Priority:** 2013/12/05 (US14/098,001)

(51) **Cl.Int./Int.Cl.** *B60R 7/02* (2006.01),
A45C 13/00 (2006.01), *B60Q 7/00* (2006.01),
B60R 11/00 (2006.01), *B62D 63/04* (2006.01),
F16M 13/06 (2006.01)
 (72) **Inventeur/Inventor:**
 MALMSTROM, CAREY D., US
 (73) **Propriétaire/Owner:**
 MALMSTROM, CAREY D., US
 (74) **Agent:** RIDOUT & MAYBEE LLP

(54) **Titre : DISPOSITIF D'ARRET MULTIFONCTIONNEL POUR COFFRE DE VOITURE**
 (54) **Title: A MULTI-FUNCTIONAL BOX STOP DEVICE FOR THE TRUNK OF A CAR**



(57) **Abrégé/Abstract:**

A box stop device includes a base member and a raised member attached to the base member. The base member has a top surface and a bottom surface. The top surface may be flat. The bottom surface may be adapted to attach to a desired surface. The

(57) **Abrégé(suite)/Abstract(continued):**

raised member may be attached to the base member and may extend approximately vertically from the top surface. The raised member may include a first side and a second side. The first side and the second side may be attached together at an angle of approximately 90 degrees.

ABSTRACT OF THE DISCLOSURE

A box stop device includes a base member and a raised member attached to the base member. The base member has a top surface and a bottom surface. The top surface may be flat. The bottom surface may be adapted to attach to a desired surface. The raised member may be attached to the base member and may extend approximately vertically from the top surface. The raised member may include a first side and a second side. The first side and the second side may be attached together at an angle of approximately 90 degrees.

A MULTI-FUNCTIONAL BOX STOP DEVICE FOR THE TRUNK OF A CARTechnical Field of the Invention

The disclosure generally relates to automobile
5 accessories like trunk accessories, and more specifically
to a multi-functional box stop device for the trunk of a
car.

Background of the Invention

10 The trunk, boot or dickie of an automobile or car is
the vehicle's main storage compartment. The trunk is most
often located at the rear of the vehicle, as storage areas
are normally at the end of the vehicle opposite to which
the engine is located. Although most cars have the trunk in
15 the rear, some cars have it in the front depending on the
location of the engine.

One problem associated with a trunk and the storage of
items like boxes in the trunk, is movement of the items or
20 boxes during use of the vehicle. Because of the nature of
a car, as it is intended to be driven, forces like
acceleration, deceleration, and centrifugal forces are
regularly acting on the vehicle and the items inside the

trunk. These forces can cause the items in the trunk, like boxes, to shift around during movement of the car. This may be undesired as it can not only cause damage to the box or items inside the box, especially fragile items, but it
5 may also cause damage to the interior of the trunk. As such, it may be desirable to restrain the items or boxes from moving or shifting around in the trunk during operation of the vehicle.

10 One solution to this problem, especially in open trunks like on station wagons or hatchbacks, is metal grids or guards to retain loose items in case of collision, or to simply create a bulkhead between the load in the trunk separated from the otherwise unprotected passenger space.
15 However, this solution is typically permanent, takes up a lot of space and does not prevent the items from shifting or moving within the grids or guards.

Another solution for items that need to be restrained
20 is the load space barrier or cargo net. These nets may be directly attached to the body structure where the net may confine luggage to the load space during movement of the vehicle. These nets have an advantage over metal guards in

that they can be rolled-up when not in use, taking up much less space than a comparable guard. However, these types of barrier or cargo nets are easily tangled, do not accommodate large objects, and are typically not very
5 durable.

Unrelated to box constraint, often time motorists carry other objects in the trunk of their car for emergency situations. During emergency situations, vehicles and
10 motorists are often faced with pulling over on the side of the road and fixing the vehicle, waiting for help, and/or abandoning the vehicle. Being with a vehicle on the side of the road is obviously a dangerous situation. As such, some motorists carry in their trunk devices used to warn
15 passing vehicles of the broken down or abandoned vehicle, and/or motorists on the side of the road. These devices stored in the trunk of the car may include flares, emergency cones/displays, etc. However, one problem with these devices may be that they are rarely used and
20 constantly take up space when not in use. As such, because of desired trunk space and/or the infrequency of emergency situations, some motorists choose not to carry such emergency devices in their car or trunk. As such, there is

clearly a need for a device that can be used to signal passing motorists of the vehicle/passengers on the side of the road that is more desirable for motorists to carry around in the trunk of a car.

5

The instant disclosure is designed to provide a multi-functional box stop device for the trunk of a car that addresses at least some of the above mentioned problems.

10

Summary

Briefly described, in select embodiments, the present disclosure of a multi-functional box stop device for the trunk of a car includes a multi-functional box stop device comprising a base member having a top surface and a bottom surface; said top surface being substantially flat; said bottom surface being adapted to attach to a desired surface; a raised member attached to said base member and extending approximately vertical from said top surface; and said raised member comprising a first side; and a second side; where said first side and said second side being attached together at an angle of approximately 90 degrees.

These and other features of the multi-functional box stop device for the trunk of a car will become more apparent to one skilled in the art from the prior Summary, and following Brief Description of the Drawings, Detailed Description, and Claims when read in light of the accompanying Detailed Drawings.

Brief Description of the Drawings

10 The present multi-functional car trunk accessory device will be better understood by reading the Detailed Description with reference to the accompanying drawings, which are not necessarily drawn to scale, and in which like reference numerals denote similar structure and refer to like elements throughout, and in which:

FIG. 1 is a perspective view of a multi-functional box stop device for the trunk of a car according to at least one example embodiment of the instant disclosure.

20

FIG. 2 is a front view of an example embodiment of the multi-functional car trunk accessory device from FIG. 1.

FIG. 3 is a back view of an example embodiment of the multi-functional box stop device for the trunk of a car from FIG. 1.

5 **FIG. 4** is a side view of an example embodiment of the multi-functional box stop device for the trunk of a car from FIG. 1.

10 **FIG. 5** is another side view of an example embodiment of the multi-functional box stop device for the trunk of a car from FIG. 1.

15 **FIG. 6** is a partially disassembled bottom perspective view of an example embodiment of the multi-functional box stop device for the trunk of a car according to at least one embodiment of the instant disclosure.

20 **FIG. 7** is a perspective environmental view of a plurality of multi-functional box stop devices for the trunk of a car securing boxes in a trunk according to select example embodiments of the instant disclosure.

FIG. 8 is a flow chart of an example embodiment of the method of securing a box in place on the floor of a trunk according to select example embodiments of the instant disclosure.

5

FIG. 9 is another perspective view of an example embodiment of the multi-functional box stop device for the trunk of a car according to select example embodiments with a flag inserted.

10

It is to be noted that the drawings presented are intended solely for the purpose of illustration and that they are, therefore, neither desired nor intended to limit the disclosure to any or all of the exact details of construction shown, except insofar as they may be deemed essential to the claimed disclosure.

15

Detailed Description

20

In describing the example embodiments of the present disclosure, as illustrated in **FIGS. 1-9**, specific terminology is employed for the sake of clarity. The present disclosure, however, is not intended to be limited

to the specific terminology so selected, and it is to be understood that each specific element includes all technical equivalents that operate in a similar manner to accomplish similar functions. Embodiments of the claims
5 may, however, be embodied in many different forms and should not be construed to be limited to the embodiments set forth herein. The examples set forth herein are non-limiting examples, and are merely examples among other possible examples.

10

Referring now to **FIGS. 1-5** by way of example, and not limitation, therein is illustrated an example embodiment of a multi-functional box stop device **10**, wherein the device **10** comprises a base member **12** and a raised member **20**. The
15 base member **12** may have a top surface **14** and a bottom surface **16**. The top surface **14** may be flat, or substantially flat, for allowing an object, like a box, to sit flat on the base member **12**. The bottom surface **16** may be adapted to attach to a desired surface **18**. The desired
20 surface **18** may be any desired surface where boxes need to be secured or restrained in place, including, but not limited to, the carpet **28** on the floor of a trunk **46**, as shown in **FIG. 7**. The raised member **20** may be attached to

the base member **12** and may extend approximately vertical from the top surface **14** of the base member **12**. The raised member **20** may include a first side **34** and a second side **35**. The first side **34** and the second side **35** may be attached
5 together at an angle **36** of approximately 90 degrees. In one embodiment, the first side **34** and the second side **35** may be attached together with a rounded corner, as shown in the Figures.

10 Embodiments of the disclosure of the multi-functional box stop device **10** may be highly durable but also highly mobile and relatively light in weight, due to the specific material composition of the device and relative thickness of the material composing the walls of the device. In one
15 embodiment, the device **10** may be made from a light weight, thin material, like plastic. In another embodiment, the device **10** may be made from a more sturdy and durable material, like a metal.

20 Referring to **FIG. 6**, the bottom surface **16** of the multi-functional box stop device **10** may be for securing the device **10** to any desired surface **18**. In one embodiment the bottom surface **16** may include a plurality of hooks **24** from

a hook and loop type fastener adapted to attach to a plurality of loops from a hook and loop type fastener. These loops may be anywhere or on any desired surface **18**, like the loops formed from the carpet **28** in the trunk of a car. However, the invention is not so limited, and may be attached to any surface, whether carpeted or not, having such loops of a hook and loop type fastener device.

Referring now to **FIGS. 1 and 6**, in select embodiments the bottom surface **16** may include a bottom hole **50** for aiding the securing of device **10** to the desired surface **18**. The bottom hole **50** may be adapted to allow a nail, screw or other securing device **52** (like nail **52** shown in **FIG. 9**) to secure the device to the desired surface **18**. For certain uses, the bottom hole **50** may be used alone to secure the device **10** to a desired surface, like a flat or smooth surface, corner, etc. Bottom hole **50** may also be used in conjunction with the hooks **24**, like for further securing device **10** to a desired surface **18** with loops, like trunk carpet **28**.

Example embodiments of the multi-functional box stop device **10** may be designed with any different shapes and

sizes, including any different shapes and sizes of the base member **12** and/or raised member **20**. In example embodiments, as shown in the Figures, the base member **12** may have a substantially square shape **32** or rectangular shape **30** with rounded corners. In other example embodiments, first side **34** and second side **35** may have substantially triangular shapes **38**.

In example embodiments, a curved top section **40** may optionally be included at the top **44** of raised member **20**. See **FIGS. 1-6**. The curved top section **40** may curve away from base member **12** and may be adapted to allow a user to grab and manipulate the device **10** when positioned with a box **22** or other device. In an example embodiment, the curved top section **40** may have a top hole **42** through it. The top hole **42** may be adapted to allow a user to attach a rope or bungee cord for further securing the device **10** in place.

In example embodiments, an ear **45** may be optionally included off of the base member **12**. See **FIGS. 1-5**. The ear **45** may be positioned off of the base member **12** on the same corner as curved top section **40**. The ear **45** may include an

ear hole **43**. The ear hole **43** in ear **45** may align with top hole **42** in curved section **40**, whereby the top hole **42** and ear hole **43** may be adapted to receive a flag **56**, as shown in **FIG. 9**, or other similar pole shaped devices. This flag **56** or similar shaped pole devices may be used for many purposes, including, but not limited to, increased visibility of device **10**, advertising, etc.

As shown in **FIG. 6**, in example embodiments, ear **45** may optionally not be included with multi-functional box stop device **10**. By providing device **10** without ear **45**, device **10** may be stackable. This stackable feature of device **10** may be a desired feature over ear **45** for some users, as it allows multiple devices **10** to be stacked on top of or inside of each other for conserving space. As one skilled in the art should readily understand, this conserved space by stacking the devices **10** may be ideal for users of multiple devices **10** in the same trunk or space.

In other example embodiments, a reflector **54** may be included on multi-functional box stop device **10**. See **FIGS. 1 and 9**. The reflector **54** may be any reflective devices, surface or paint and may be positioned anywhere on device

10 or device **10** may be covered with reflector **54**. The reflector **54**, as should be obvious to one skilled in the art, may be for increasing the visibility of device **10**, especially in dark situations. As shown in **FIG. 1**, in one
5 embodiment, reflector **54** may be a reflective paint, coating or sticker positioned all over first side **34** and/or second side **35** of raised member **20**. As shown in **FIG. 9**, in an example embodiment, reflector **54** may be a reflective paint, coating or sticker positioned on a portion of first side **34**
10 and/or second side **35** of raised member **20**.

Referring to **FIG. 7**, when the device **10** is positioned with a box **22** where the base member **12** is under the box **22** and the raised member **20** is against the box **22**, the bottom
15 surface **16** may hold the device **10** in place on desired surface **18** thereby stopping, restraining or securing the box **22** from moving on the desired surface **18**.

Although the instant disclosure is directed herein
20 toward a multi-functional box stop device **10** for the trunk **46** of a car or automobile **48**, as shown in **FIG. 7**, the instant disclosure is not so limited to trunk, cars and/or automobiles, and can be used for other situations where a

box needs to be held in position on a desired surface,
where a cone or similar device is desired, where a small
flag or rod needs to be held, and/or for mounting to the
corner or surface of any device for advertising, danger
5 awareness, etc.

In more detail, referring to the disclosure depicted
in **FIG. 7**, the multi-functional box stop device **10** may be
used to secure items in the trunk of a car, like boxes,
10 from sliding or shifting. In general, example embodiments
of the multi-functional box stop device **10** for the trunk **46**
of a car **48**, may include a base member **12** and a raised
member **20**. The base member **12** may have a top surface **14** and
a bottom surface **16**. The base member **12** may be for
15 providing the base for object like boxes to rest on. The
top surface **14** of base member **12** may be flat, or
substantially flat, for allowing an object, like a box, to
sit flat on the base member **12**. In addition, the base
member **12** may provide the base for attaching to a desired
20 surface. The bottom surface **16** may be adapted to attach to
a desired surface **18**. The desired surface **18** may be any
desired surface for securing the device in place,
including, but not limited to, the carpet **28** on the floor

of a trunk **46**, or other desired surfaces. Also, base member **12** may provide the base for the attachment of raised member **20**. The raised member **20** may be attached to the base member **12** and may extend approximately vertical from the top surface **14** of the base member **12**. The raised member **20** may include a first side **34** and a second side **35**. The first side **34** and the second side **35** may be attached together at an angle **36** of approximately 90 degrees. The device **10** may also optionally include a curved top section **40** with a top hole **42** and/or an ear **45** off of base member **12** with an ear hole **43**.

Still referring to **FIG. 7**, in one embodiment the multi-functional box stop device **10** may be used for securing items, like boxes, from shifting or sliding in the trunk **46** of a car **48**. When the device **10** is positioned with a box **22** where the base member **12** is under the box **22** and the raised member **20** is against the box **22**, the bottom surface **16** may hold the device **10** in place thereby stopping the box **22** from moving or shifting on the desired surface **18**. This box stop function may be accomplished in numerous manners, including using one or multiple devices **10** on the boxes or other similar objects. For example, if a box **22**

is positioned in the corner of the trunk, one device **10** may be positioned on the opposing corner of the box **22** for securing the box in place in the trunk. As another example, if a box **22** is positioned against the wall of the trunk, two devices **10** may be positioned on the two opposing corners of the box **22** from the wall for securing the box in place in the trunk. As yet another example, if the box **22** is positioned in the middle of the trunk, three or four devices **10** may be utilized for securing the box **22** in place.

Referring now to **FIG. 8**, an example embodiment of a method **200** of securing a box in place on the floor of a trunk is shown. In block **210** the multi-functional box stop device **10** is provided, including any of the various embodiments shown and described herein. In block **220**, a box is placed into the trunk of a car against the side or corner of the trunk. In block **230**, the multi-functional box stop device is positioned with the box where the base member is under the box and the raised member is against the box.

Positioning the multi-functional box stop device **10** with the box where the base member **12** is under the box and the raised member **20** is against the box may include one or more of blocks 240, 250, and 260. In block **240**, one corner
5 of the box is raised. In block **250**, the multi-functional box stop device is placed under the raised corner of the box. And finally, in block **260**, the raised corner of the box is lowered onto the box stop.

10 Referring to FIG. 9, multi-functional box stop device **10** may optionally be used as a flag holder. In general, example embodiments of the multi-functional box stop device **10** as a flag holder may include a base member **12** and a raised member **20**. The base member **12** may have a top surface
15 **14** and a bottom surface **16**. The base member **12** may be for providing the base for device **10** to stand up. The top surface **14** of base member **12** may be flat, or substantially flat, for allowing an object, like a box, to sit flat on the base member **12**, thereby securing device **10** upright. In
20 addition, the base member **12** may provide the base for attaching to a desired surface. The bottom surface **16** may be adapted to attach to a desired surface **18**. The desired surface **18** may be any desired surface for securing the

device in place. Also, base member **12** may provide the base for the attachment of raised surface **20**. The raised member **20** may be attached to the base member **12** and may extend approximately vertical from the top surface **14** of the base member **12**. The raised member **20** may include a first side **34** and a second side **35**. The first side **34** and the second side **35** may be attached together at an angle **36** of approximately 90 degrees. The device **10** may also include a curved top section **40** with a top hole **42** and an ear **45** off of base member **12** with an ear hole **43**. The ear hole **43** may align with the top hole **42**, whereby the top hole **42** and ear hole **43** are adapted to receive flag **56**.

As shown in **FIG. 9**, in this example embodiment, device **10** may be used as a flag holder, like a desk flag holder. As should be apparent by one skilled in the art, device **10** may be used as a flag holder anywhere a flag is desired for advertisement or danger indication, like stairs. The hook layer **24** may aid in positioning and securing the flag holder device **10** on various desired surfaces **18**. In addition, the bottom hole **50** may be adapted to allow a nail, screw or other securing device **52** to secure the device to the desired surface **18**. As such, the hoop layer

24 and/or bottom hole **50** may be used for positioning securing the flag holder device **10** in place on any desired surface **18**.

5 Along with these unique functions of a box stop and/or flag holder, as described above and shown in **FIGS.7-9**, the multi-functional box stop device **10** may also be used in many different desired functions or applications. As merely examples, the device **10** may be used as: an emergency
10 signal cone in which the device **10** is placed outside of a car to alert oncoming traffic (flag **56** and/or reflector **54** may increase the visibility); and a surface or corner mount, where device **10** may be mounted to a surface or corner, which in combination with flag **56** and/or reflector
15 **54**, may advertise the flag **56** on any surface or corner and/or indicate directions or location of danger in area, or any other desired uses. The device **10** may also be used for any other desired functions or applications as apparent from the instant disclosure or later discovered as useful
20 by the user.

The foregoing description and drawings comprise illustrative embodiments. Having thus described example

embodiments, it should be noted by those skilled in the art that the within disclosures are example only, and that various other alternatives, adaptations, and modifications may be made within the scope of the present disclosure.

5 Merely listing or numbering the steps of a method in a certain order does not constitute any limitation on the order of the steps of that method. Many modifications and other embodiments will come to mind to one skilled in the art to which this disclosure pertains having the benefit of

10 the teachings presented in the foregoing descriptions and the associated drawings. Although specific terms may be employed herein, they are used in a generic and descriptive sense only and not for purposes of limitation. Accordingly, the present disclosure is not limited to the

15 specific embodiments illustrated herein, but is limited only by the following claims.

WHAT IS CLAIMED IS:

1. A multi-functional box stop device comprising:

a thin planar base member having a substantially square or rectangular shape with a flat top surface and a bottom surface adapted to attach to a desired surface;

a raised member attached to the base member on two adjacent sides and extending approximately vertical from the top surface, the raised member comprising:

a thin planar first side having a substantially triangular shape;

a thin planar second side having a substantially triangular shape, the first side and the second side being attached together at an angle of approximately 90 degrees;

a first reflector and a second reflector, wherein:

said first reflector is positioned on said first side, said first reflector having a substantially triangular shape matching said substantially triangular shape of said first side with sides parallel to said substantially triangular shape of said first side; and

said second reflector is positioned on said second side, said second reflector having a substantially triangular shape matching said substantially triangular shape of said second side with sides parallel to said substantially triangular shape of said second side.

2. The multi-functional box stop device of claim 1 wherein, when the device is positioned with a box where the base member is under the box and the raised member is against the box, the bottom surface holds the device in place thereby stopping the box from moving on the desired surface.

3. The multi-functional box stop device of claim 1, wherein the raised member comprises a curved top section curving away from the base member and adapted to allow a user to grab and manipulate the box stop device when positioned with a box.
4. The multi-functional box stop device of claim 3, wherein said curved top section comprises a top hole adapted for attaching a rope or bungee cord for further securing the box stop device in place.
5. The multi-functional box stop device of claim 4, wherein the base member comprises an ear with an ear hole, the ear hole aligning with the top hole, whereby the top hole and ear hole are adapted to receive a flag.
6. The multi-functional box stop device of claim 1, wherein the bottom surface comprises a plurality of hooks from a hook and loop type fastener adapted to attach to a plurality of loops from a hook and loop type fastener.
7. The multi-functional box stop device of claim 6, wherein the plurality of loops comprises trunk carpet.
8. The multi-functional box stop device of claim 1, wherein the bottom surface comprises a bottom hole adapted to allow a nail, screw or other securing device to secure the device to said desired surface.
9. The multi-functional box stop device of claim 1, wherein the base member has rounded corners.
10. The multi-functional box stop device of claim 10 wherein said first reflector and said second reflector being a reflective paint, coating or sticker.

11. A multi-functional box stop device comprising:

a base member having a substantially square or rectangular shape with a flat top surface and a bottom surface adapted to attach to a desired surface;

a raised member attached to the base member and extending approximately vertical from the top surface, the raised member comprising:

a first side having a substantially triangular shape; and

a second side having a substantially triangular shape,

the first side and the second side being attached together at an angle of approximately 90 degrees;

a curved top section curving away from the base member and adapted to allow a user to grab and manipulate the box stop device when positioned with a box, said curved top section comprises a top hole adapted for attaching a rope or bungee cord for further securing the box stop device in place; and

an ear with an ear hole, the ear hole aligning with the top hole, whereby the top hole and ear hole are adapted to receive a flag.

12. A multi-functional box stop device comprising:

a base member having a substantially square or rectangular shape with a flat top surface and a bottom surface adapted to attach to a desired surface;

a raised member attached to the base member and extending approximately vertical from the top surface, the raised member comprising:

a first side having a substantially triangular shape; and

a second side having a substantially triangular shape,

the first side and the second side being attached together at an angle of approximately 90 degrees;

said raised member further comprising:

a curved top section curving away from the base member and adapted to allow a user to grab and manipulate the box stop device when positioned with a box, said curved top section comprises a top hole adapted for attaching a rope or bungee cord for further securing the box stop device in place, and an ear with an ear hole, the ear hole aligning with the top hole, whereby the top hole and ear hole are adapted to receive a flag; and/or

a reflector positioned on said first side, and/or on said second side.

13. The multi-functional box stop device of claim 1, wherein the substantially triangular shape of said second side matching the substantially triangular shape of said first side.

1/7

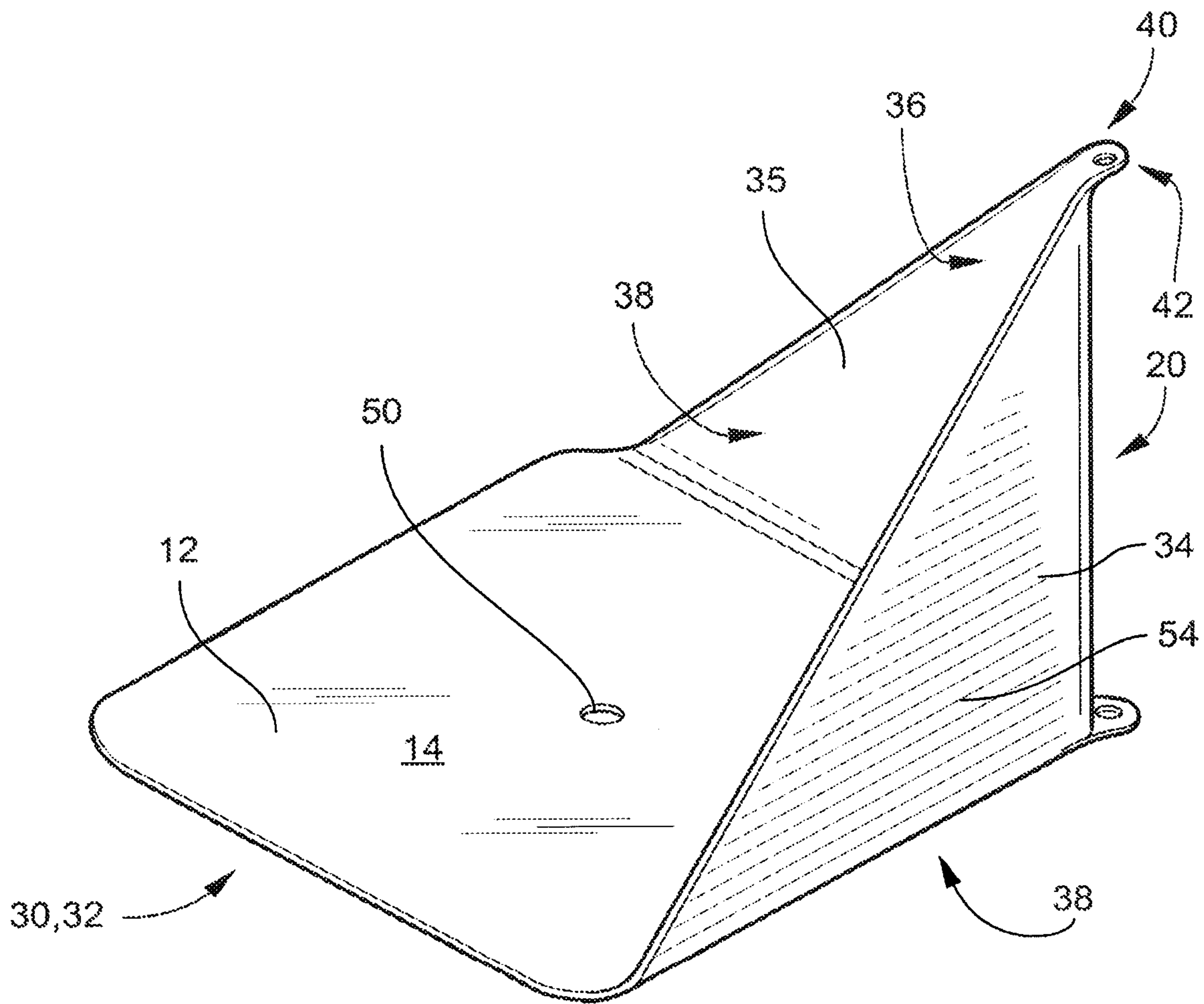
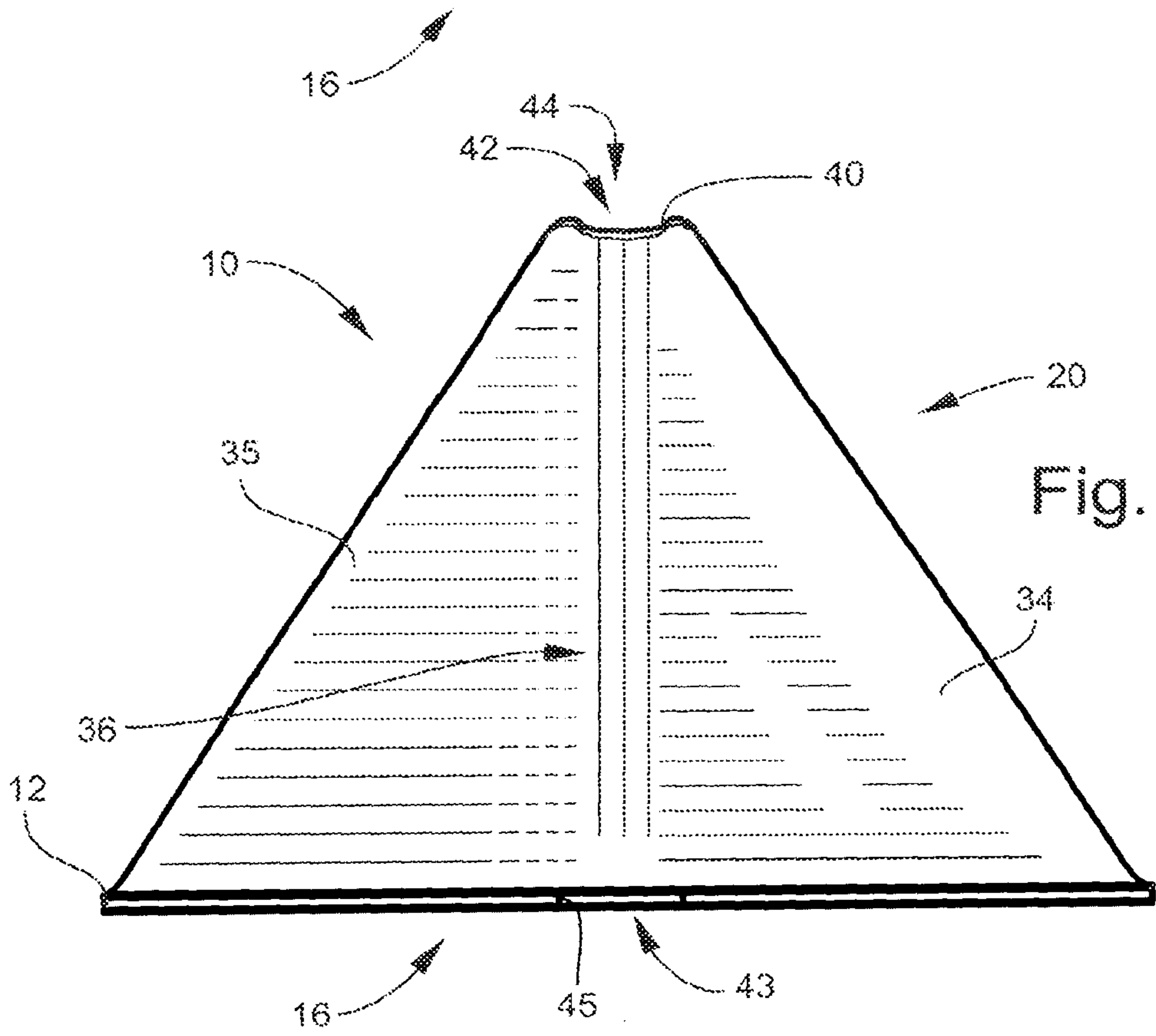
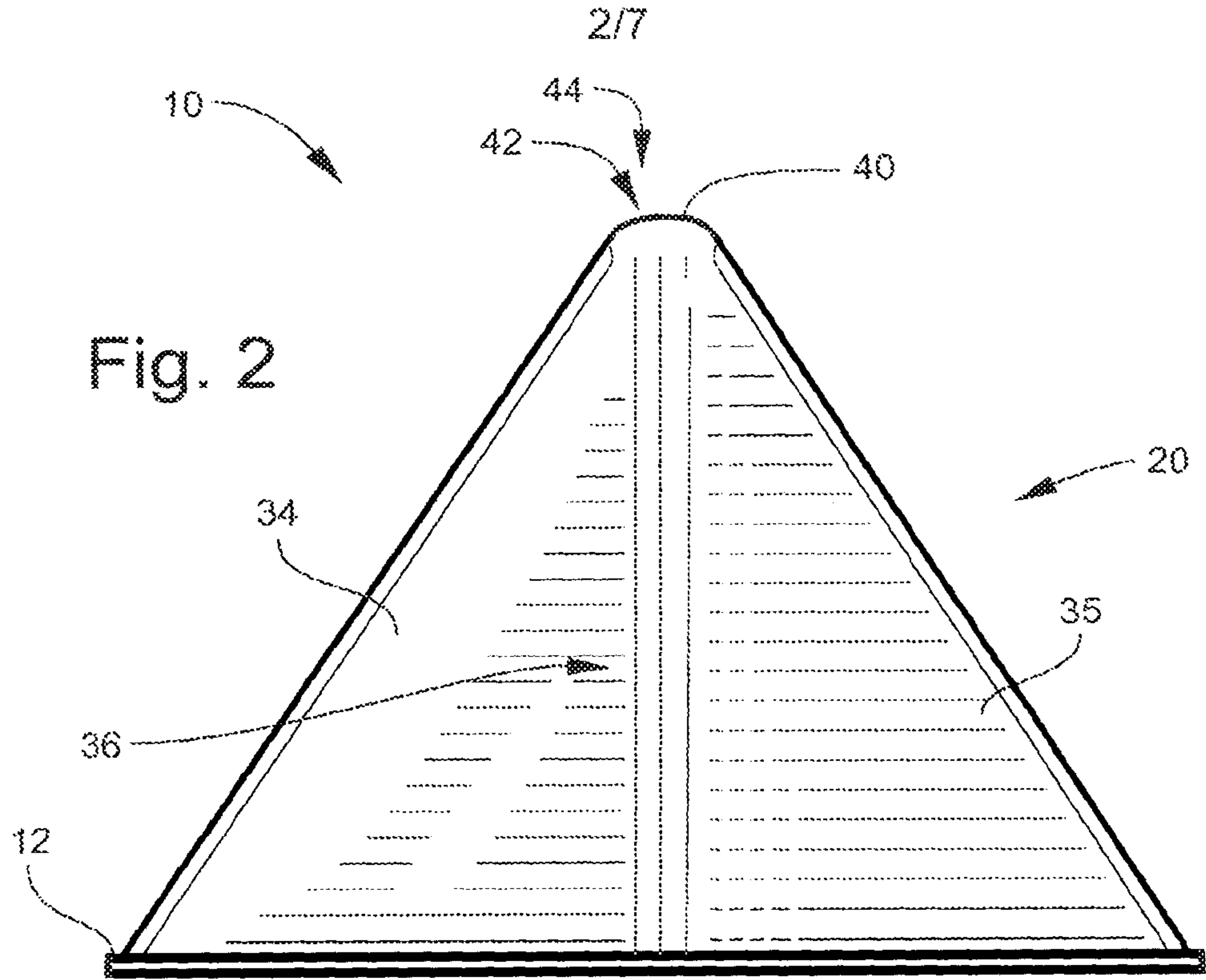

Fig. 1



3/7

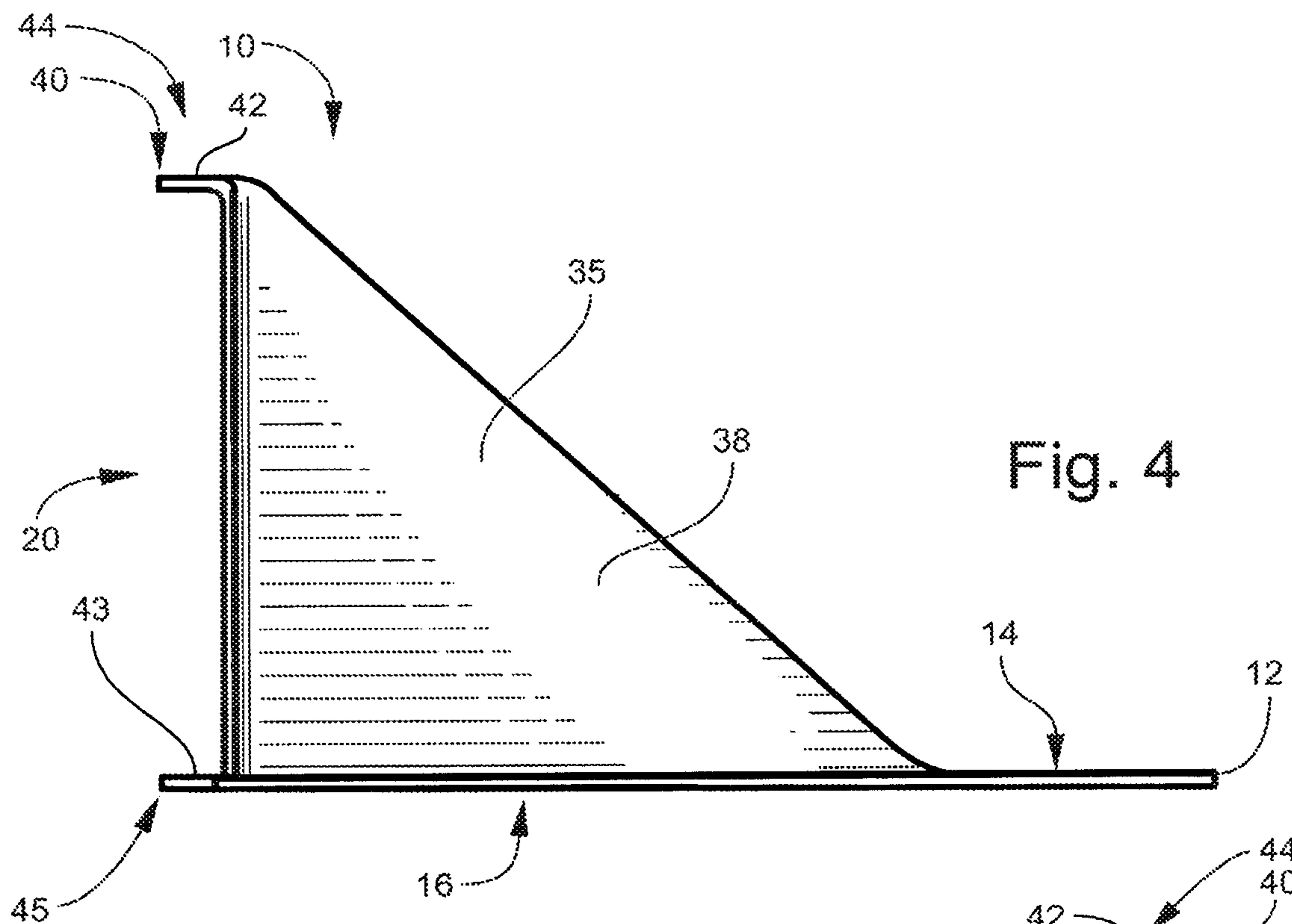

Fig. 4

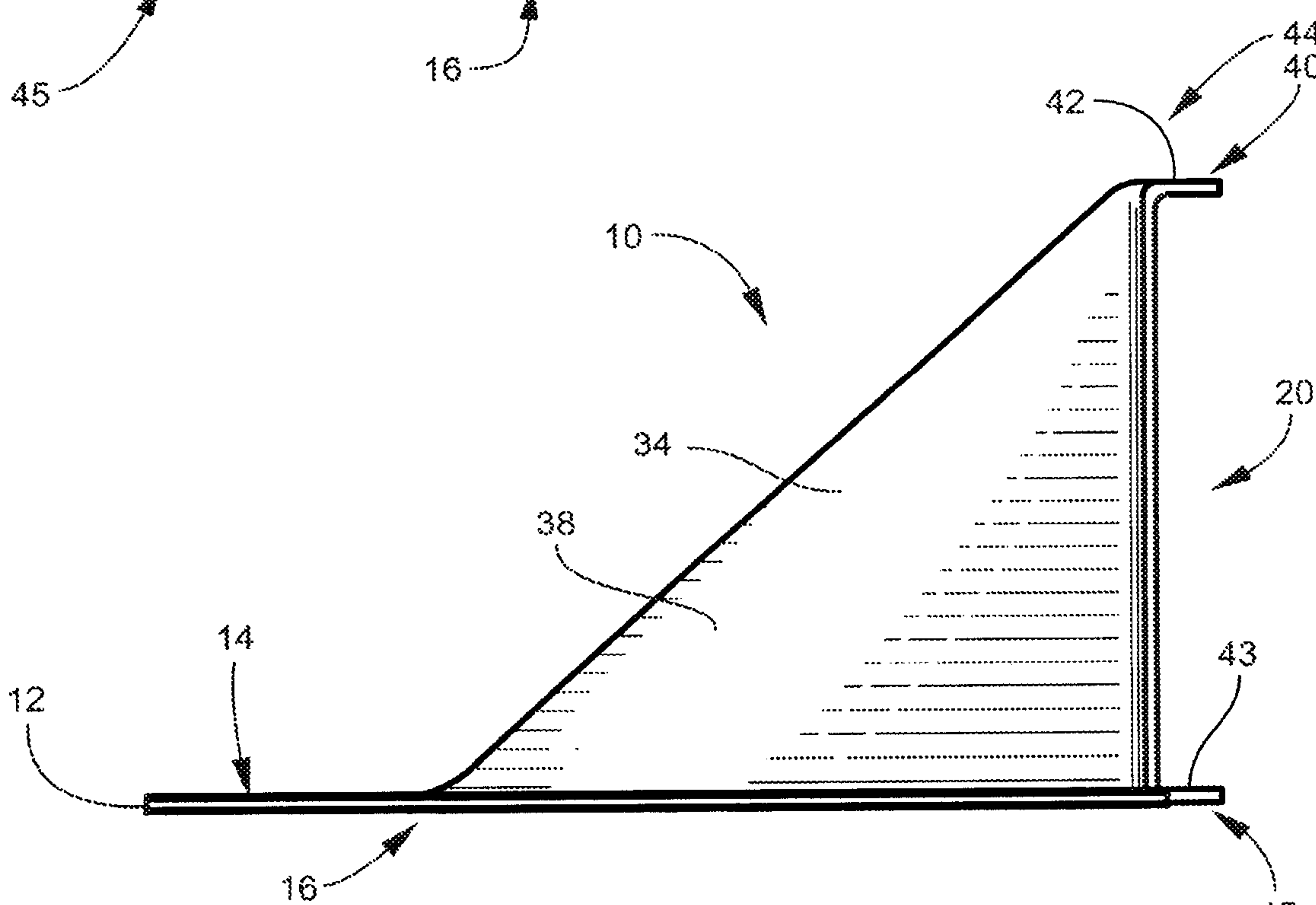
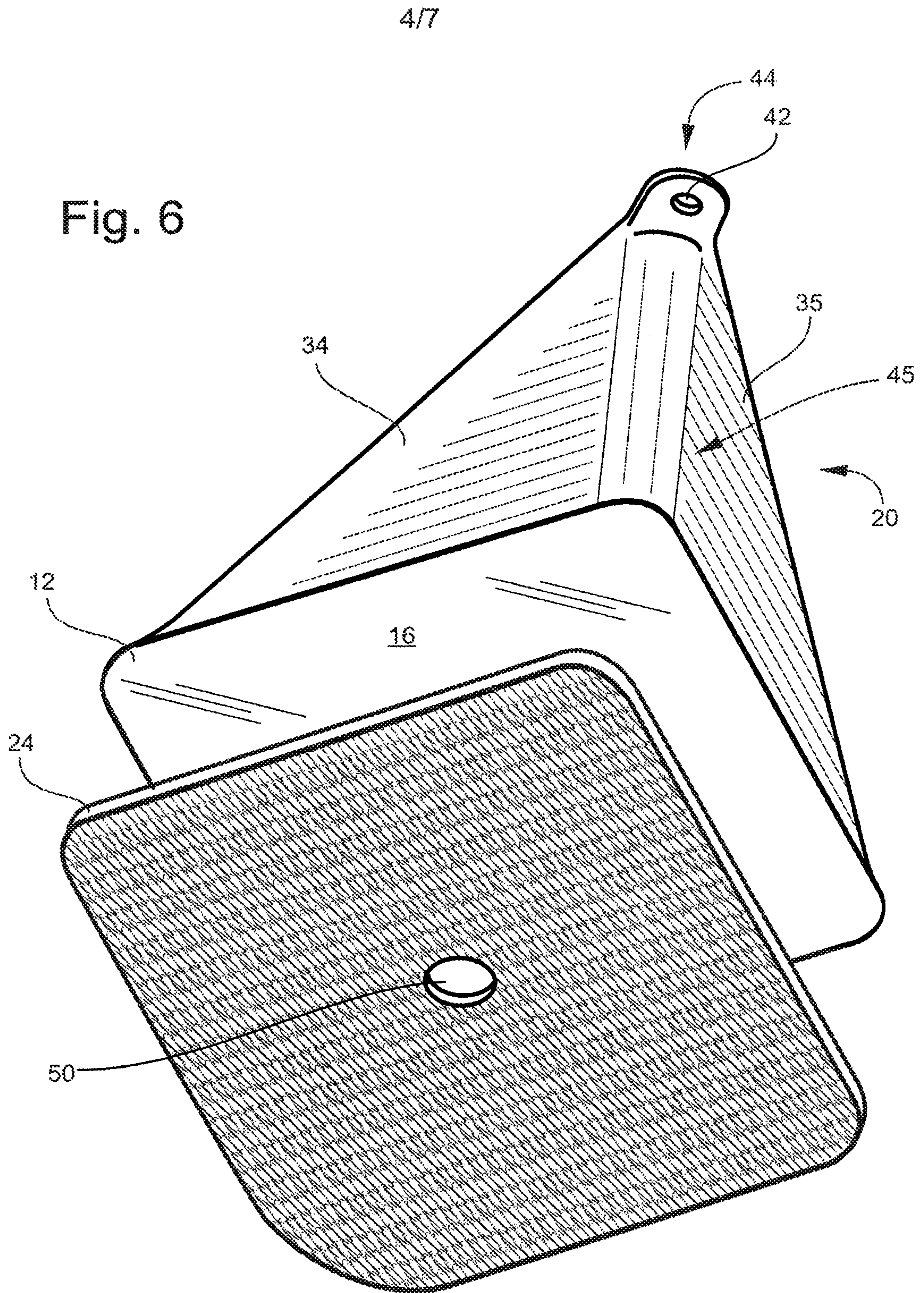

Fig. 5

Fig. 6



6/7

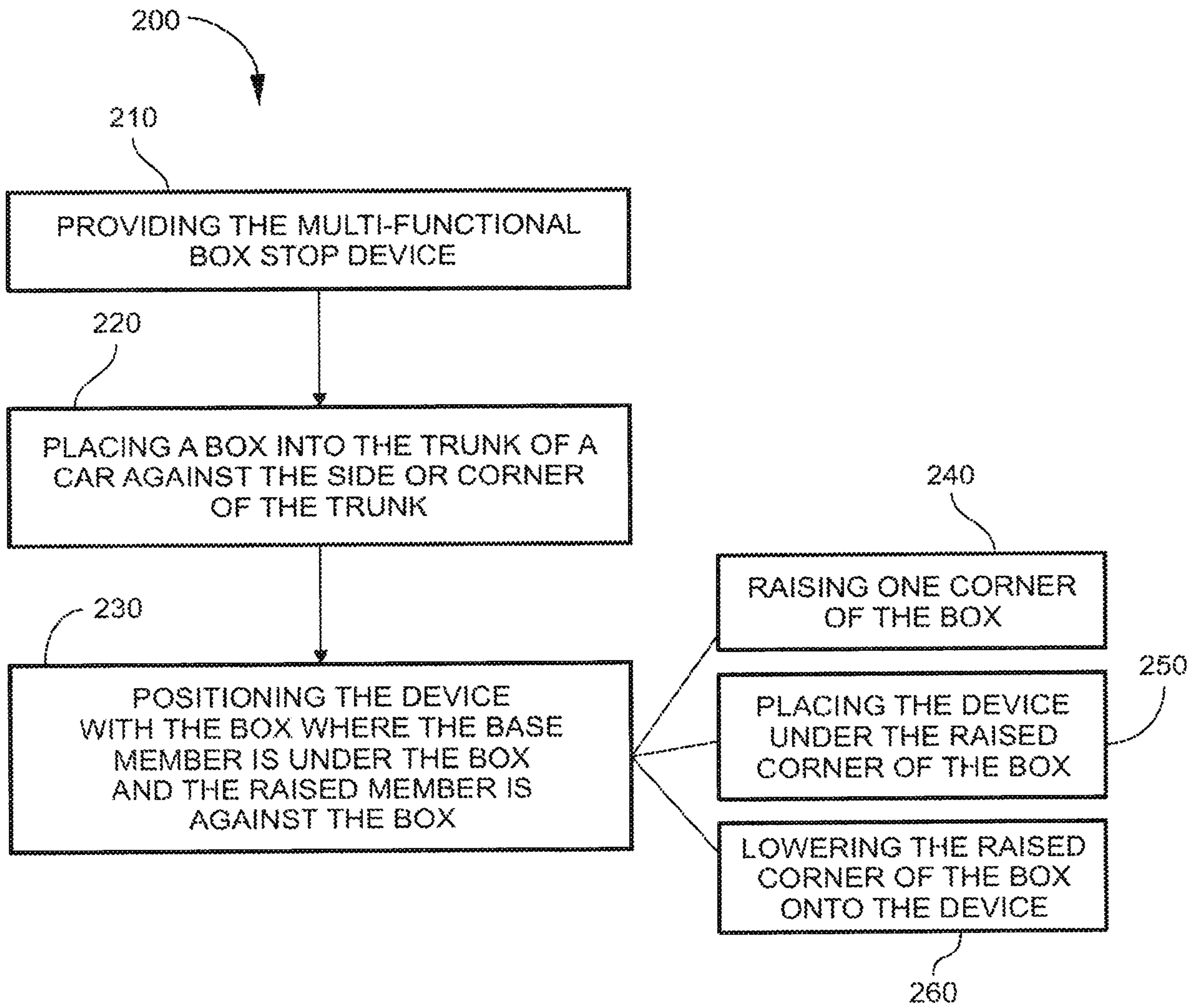

Fig. 8

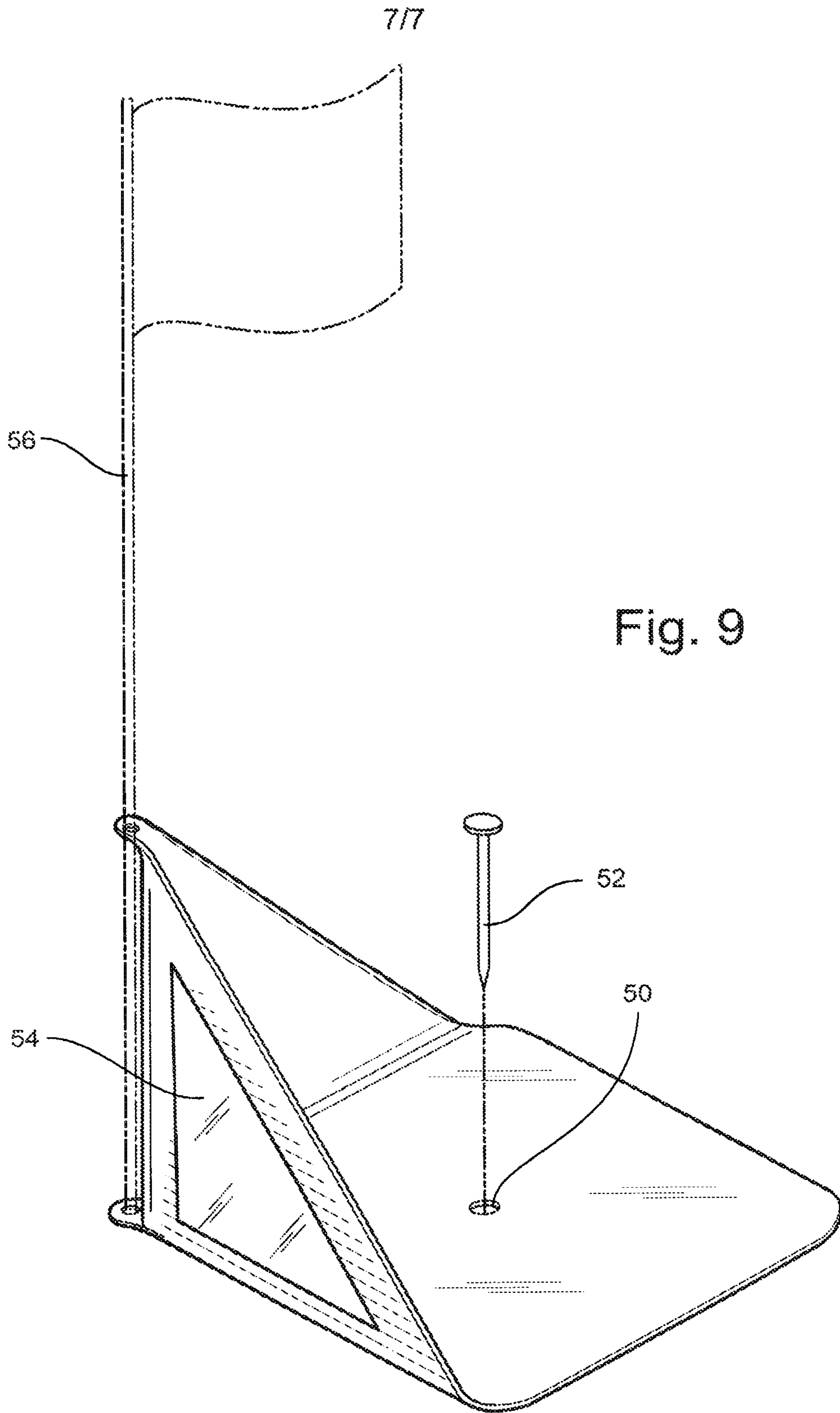

Fig. 9

