



Europäisches Patentamt
European Patent Office
Office européen des brevets



Publication number:

0 420 234 A2

12

EUROPEAN PATENT APPLICATION

21 Application number: 90118562.9

51 Int. Cl.⁵: B41F 7/10, B41F 11/02

22 Date of filing: 27.09.90

30 Priority: 29.09.89 JP 252426/89

43 Date of publication of application:
03.04.91 Bulletin 91/14

64 Designated Contracting States:
AT CH DE FR GB IT LI NL SE

71 Applicant: Komori Corporation
11-1, Azumabashi 3-chome
Sumida-ku Tokyo(JP)

72 Inventor: Funada, Hitoshi, c/o Sekiyado Plant,

Komori Co.
210, Kirigasaku, Sekiyadomachi
Higashikatsushika-gun, Chiba(JP)
Inventor: Hoshi, Toshio, c/o Sekiyado Plant,
Komori Co.
210, Kirigasaku, Sekiyadomachi
Higashikatsushika-gun, Chiba(JP)

74 Representative: Kahler, Kurt
Patentanwalt Dipl.-Ing. Kurt Kahler
Gerberstrasse 3 Postfach 1249
W-8948 Mindelheim(DE)

54 Multicolor printing press.

57 A multicolor printing press includes an impression cylinder (12), a plurality of blanket cylinders (14, 15) juxtaposed in the circumferential direction of the impression cylinder (12) and arranged in rolling contact with a circumferential surface of the impression cylinder (12), a plurality of plate cylinders (16, 17, 20, 21, 22) juxtaposed in the circumferential direction of each of the plurality of blanket cylinders (14, 15)

and arranged in rolling contact with a circumferential surface of each of the plurality of blanket cylinders (14, 15), and a unit (18, 19, 23, 24), arranged for each of the plurality of plate cylinders (16, 17, 20, 21, 22), for supplying an ink and dampening water to each of the plurality of plate cylinders.

EP 0 420 234 A2

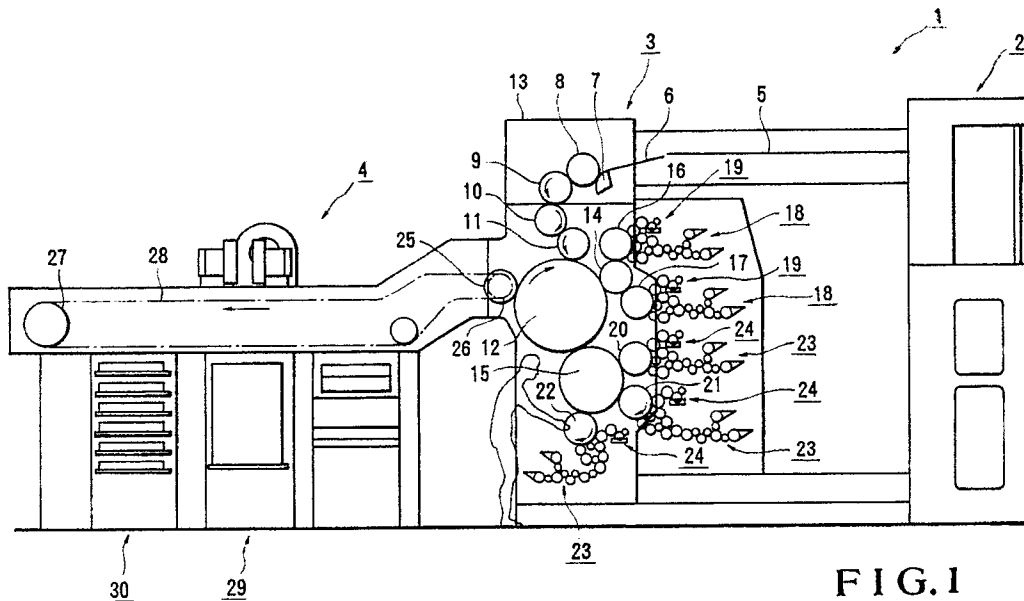

FIG. 1

MULTICOLOR PRINTING PRESS

Background of the Invention

The present invention relates to a multicolor printing press and, more particularly, to a multicolor printing press for printing ground tint images of securities such as banknotes and stocks and bonds.

A conventional offset printing press has been generally used to print a fine printing image in, for example, ground tint printing for securities such as banknotes, and stocks and bonds. A conventional printing press of this type has a pair of blanket cylinders which are in rolling contact with each other and each of which has a diameter twice that of a plate cylinder. A plurality of plate cylinders as satellite cylinders are in rolling contact with the circumferential surface of each blanket cylinder. A printing image forming unit is arranged for each plate cylinder. A paper feed transfer cylinder and a paper delivery transfer cylinder are in rolling contact with the circumferential surface of the upstream blanket cylinder.

With this arrangement, a sheet fed on a feed-board by a sheet feeder is fed to the upstream blanket cylinder through swing pre-grippers and the paper feed transfer cylinder upon gripping of grippers and is then delivered to a delivery unit by delivery chains looped around a sprocket coaxial with the delivery cylinder upon further gripping of grippers.

On the other hand, a printing image, i.e., a pattern is formed on a plate of each plate cylinder by the corresponding printing image forming unit. The patterns of all the plates are transferred to both the blanket cylinders. These printing images are transferred to both surfaces of the sheet which receives a printing pressure from the blanket cylinders when it passes between the blanket cylinders, thereby performing printing.

In this case, a letterpress plate is generally mounted on each plate cylinder. However, in recent years, a planographic plate such as an offset plate becomes popular. In this case, the printing image forming unit comprises an inking unit and a dampening unit.

When the planographic plate is mounted on each plate cylinder, as described above, a water film is present in a non-image plate surface portion having no printing image. When a printing image is transferred from the plate surface to the corresponding blanket cylinder, this thin water film is also transferred to this blanket cylinder. Of the plurality of plate cylinders aligned in the circumferential direction of the blanket cylinder, a printing image from the next plate cylinder is transferred

onto the water film transferred from an upstream plate cylinder to the blanket cylinder. Therefore, water contents of printing images are increased toward the downstream direction, and printing densities of these printing images are gradually decreased to degrade the quality of the printed matters.

A large amount of alcohol is mixed in water supplied to a dampening stab in the dampening unit to quickly dry the water film transferred to a blanket mounted on the circumferential surface of each blanket cylinder, or inks having different densities are used in conventional arrangements. These countermeasures can cope with only transfer at a maximum of three times. When planographic plates are used in all four plate cylinders, it is almost difficult to obtain satisfactory printed matters. Since the number of plates tends to be increased to prevent more sophisticated counterfeits, a strong demand has thus arisen for developing a printing press capable of planographic printing of four or more colors.

Summary of the Invention

It is an object of the present invention to provide a multicolor printing press capable of greatly improving quality of planographic printing and alignment of images of different planographic plates.

It is another object of the present invention to provide a multicolor printing press capable of printing securities at low cost without allowing counterfeits.

In order to achieve the above objects of the present invention, there is provided a multicolor printing press comprising an impression cylinder, a plurality of blanket cylinders juxtaposed in a circumferential direction of the impression cylinder and arranged in rolling contact with a circumferential surface of the impression cylinder, a plurality of plate cylinders juxtaposed in a circumferential direction of each of the plurality of blanket cylinders and arranged in rolling contact with a circumferential surface of each of the plurality of blanket cylinders, and a unit, arranged for each of the plurality of plate cylinders, for supplying an ink and dampening water to each of the plurality of plate cylinders.

A sheet fed from a paper feeder sequentially passes between an impression cylinder and each blanket cylinder and is then delivered to a delivery unit. During printing, since printing images formed on plate surfaces of a plurality of plate cylinders

correspondingly in rolling contact with a blanket surface of each blanket cylinder are transferred to this blanket surface, the printing images are transferred to the sheet which passes through the impression cylinder and the corresponding blanket cylinder. In this case, even if the number of plate cylinders is, e.g., five, only a few plate cylinders are in rolling contact with each blanket cylinder. Therefore, printing quality is not substantially adversely affected by a water film. This thin water film can be absorbed by the sheet during feeding between the upstream and the downstream blanket cylinders.

Brief Description of the Drawings

Fig. 1 is a schematic side view of a multicolor ground tint printing press for securities according to an embodiment of the present invention;

Fig. 2 is a schematic side view of a combination printing press using the press shown in Fig. 1; and

Figs. 3 to 5 are schematic side views of combination printing presses according to other embodiments of the present invention.

Description of the Preferred Embodiments

Figs. 1 and 2 show a multicolor printing press according to an embodiment of the present invention, in which Fig. 1 shows a multicolor ground tint printing press for securities, and Fig. 2 shows a combination printing press using the press shown in Fig. 1.

Referring to Figs. 1 and 2, a ground tint printing press 1 comprises a paper feeder 2, a printing unit 3, and a delivery unit 4. The paper feeder 2 has a stack board (not shown) which supports sheets and can be automatically vertically moved. The paper feeder 2 also has a sucker unit (not shown) for picking up the sheets stacked on the stack board one by one from the uppermost sheet and feeding each sheet to a feeder board 5.

Swing pre-grippers 7 are arranged in the printing unit 3 to grip the sheet fed from the feeder board 5 to a feedboard 6 and are pivoted while gripping the sheet. A plurality of transfer cylinders 8, 9, 10, and 11 which have sheet grippers arranged in their grooves formed in the circumferential surfaces and are in rolling contact with each other are arranged at the downstream of the swing pre-grippers 7. Reference numeral 12 denotes an impression cylinder in rolling contact with the transfer cylinder 11 at the downstream position thereof. The impression cylinder 12 has a diameter three times that of the transfer cylinder 11. The impression cylinder 12 is rotatably supported on right and

left frames 13 and can be rotated in a direction indicated by an arrow in Fig. 1. Blanket surfaces of first and second blanket cylinders 14 and 15 having blankets on their circumferential surfaces are rolling contact with the impression cylinder 12. In this case, the first and second blanket cylinders 14 and 15 are juxtaposed in the circumferential direction of the impression cylinder 12. Plate surfaces of plate cylinders 16 and 17 having plates thereon are in rolling contact with the blanket surface of the blanket cylinder 14 obliquely above and sideways the first blanket cylinder 14. An inking unit 18 for supplying an ink to the corresponding plate surface and a dampening unit 19 for supplying dampening water to the corresponding plate surface are arranged for each of the plate cylinders 16 and 17. Plate surfaces of plate cylinders 20, 21, and 22 having plates thereon are in rolling contact with the circumferential surface of the second blanket cylinder 15 sideways and below the second blanket cylinder 15. An inking unit 23 for supplying an ink to a corresponding plate surface and a dampening unit 24 for supplying dampening water to the corresponding plate surface are arranged for each of the plate cylinders 20, 21, and 22.

Reference numeral 25 denotes a delivery cylinder arranged sideways the impression cylinder 12. Sprockets 26 are mounted on both end shafts of the delivery cylinder 25. A pair of right and left delivery chains 28 running in a direction indicated by an arrow in Fig. 1 are looped between the sprockets 26 and sprockets 27 in the delivery unit 4. Plural pairs of grippers and gripper pads are axially juxtaposed on gripper rods bridged between the pair of right and left delivery chains 28 at predetermined intervals. Reference numerals 29 and 30 denote first and second piles for stacking sheets which drop from the delivery chains 28 upon release of the sheets from the grippers.

An operation of the ground tint printing press having the above structure will be described below. A sheet picked up by a suction unit in the paper feeder 2 and fed onto the feeder board 5 is fed out to a feedboard 6 by a paper feed tape or the like. Upon gripping and regripping of grippers, the sheet is gripped by grippers of the impression cylinder 12 through the swing pre-grippers 7 and the transfer cylinders 8, 9, 10, and 11. Upon rotation of the impression cylinder 12, the sheet is fed in contact with the circumferential surface of the impression cylinder 12. On the other hand, printing images are formed on the plate surfaces of the upper plate cylinders 16 and 17 by the corresponding inking units 18 and the corresponding dampening units 19. These printing images are transferred to the blanket surface of the first blanket cylinder 14 and are then transferred to the sheet which passes between the first blanket cylinder 14 and the im-

pression cylinder 12. Printing images are also formed on the plate surfaces of the lower plate cylinders 20, 21, and 22 by the corresponding inking units 23 and the corresponding dampening units 24. These printing images are transferred to the blanket surface of the second blanket cylinder 15 and are then transferred to the sheet which passes between the second blanket cylinder 15 and the impression cylinder 12. Upon regripping of grippers, the printed sheet is fed by the delivery chains 28 looped between the sprockets 26 coaxial with the delivery cylinder 25 and the sprockets 27 in the delivery unit 4. The printed sheets are then alternately delivered to the piles 29 and 30.

In the above printing operation, a five-color halftone printing press has the five plate cylinders 16, 17, 20, 21, and 22. Of these plate cylinders, two upper plate cylinders are arranged in rolling contact with the blanket cylinder 14, and three lower plate cylinders are arranged in rolling contact with the blanket cylinder 15. Even if the dampening water is supplied from the dampening units 19 and 24 to the plate surfaces, an influence of the water film can be reduced, unlike in the conventional arrangement. Transfer in the practical printing range is performed between the blanket cylinder 14 or 15 and the plate cylinder 16 or the like. More specifically, a water film received at a contact point between the first blanket cylinder 14 and the impression cylinder 12 in transfer of a printing image from the blanket cylinder 14 to the sheet is absorbed by the sheet at a position passing through this contact position. Therefore, the water film does not impose any adverse affect at a contact point between the second blanket cylinder 15 and the impression cylinder 12.

Fig. 2 shows a combination printing press which employs the same ground tint printing portion shown in Fig. 1. In this application example, a plurality of transfer cylinders 31, 32, 33, 34, and 35 and an intaglio impression cylinder 36 are arranged between the impression cylinder 12 and the delivery unit. With this arrangement, intaglio printing can be performed after ground tint printing is performed by offset printing. The arrangement and effect of the ground tint printing portion are the same as those of the embodiment shown in Fig. 1.

Figs. 3, 4, and 5 show combination printing presses according to other embodiments of the present invention. In the embodiment shown in Fig. 3, the diameter of a second blanket cylinder 40 is three times that of each plate cylinder and is equal to that of an impression cylinder 12. Other arrangements in Fig. 3 are substantially the same as those in Fig. 2. In the embodiment shown in Fig. 4, each of the diameters of first and second blanket cylinders 50 and 51 is twice that of each plate cylinder. Other arrangements in Fig. 4 are substan-

tially the same as those in Fig. 2. In the embodiment shown in Fig. 5, the diameter of a first blanket cylinder 60 is twice that of each plate cylinder, and the diameter of a second blanket cylinder 61 is three times that of each plate cylinder. Other arrangements in Fig. 5 are substantially the same as those in Fig.2.

The above embodiments exemplify multicolor ground tint printing presses for securities. However, the present invention is equally applicable to a printing press for printing other fine printing patterns with high precision.

Each embodiment described above exemplifies a sheet-fed printing press for feeding cut sheets with grippers. However, the present invention is also applicable to a printing press using a roll of paper.

As has been apparent from the above description, according to the present invention, there is provided a multicolor printing press comprising an impression cylinder, a plurality of blanket cylinders juxtaposed in the circumferential direction of the impression cylinder and arranged in rolling contact with a circumferential surface of the impression cylinder, a plurality of plate cylinders juxtaposed in the circumferential direction of each of the plurality of blanket cylinders and arranged in rolling contact with a circumferential surface of each of the plurality of blanket cylinders, and a unit, arranged for each of the plurality of plate cylinders, for supplying an ink and dampening water to each of the plurality of plate cylinders. Since the plurality of plate cylinders are divided into groups, and each group is in rolling contact with each of the plurality of blanket cylinders, a water film can be substantially eliminated even if planographic printing using dampening units is performed, thereby greatly improving quality of printing matters. In addition, since transfer for a plurality of times is performed on the same impression cylinder, high-precision printing can be performed as compared with conventional commercial printing in which transfer operations are performed on different impression cylinders, thereby sufficiently coping with counterfeit printing using a commercial printing press. Moreover, since four-color or more halftone ground tint printing in four or more colors can be performed by only planographic printing, inexpensive planographic plates can be used to print securities which cannot be easily counterfeited at low cost.

Claims

1. A multicolor printing press characterized by comprising an impression cylinder (12), a plurality of blanket cylinders (14, 15; 14, 40; 50, 51; 60, 61) juxtaposed in a circumferential direction of said

impression cylinder (12) and arranged in rolling contact with a circumferential surface of said impression cylinder (12), a plurality of plate cylinders (16, 17, 20, 21, 22) juxtaposed in a circumferential direction of each of said plurality of blanket cylinders (14, 15; 14, 40; 50, 51; 60, 61) and arranged in rolling contact with a circumferential surface of said each blanket cylinder (14, 15; 14, 40; 50, 51; 60, 61), and a unit (18, 19, 23, 24) arranged for each of said plurality of plate cylinders (16, 17, 20, 21, 22), for supplying an ink and dampening water to said each plate cylinder (16, 17, 20, 21, 22).

2. A printing press according to claim 1, wherein a diameter of said each blanket cylinder (14, 15; 14, 40; 50, 51; 60, 61) is an integer multiple of a diameter of said each plate cylinder (16, 17, 20, 21, 22), and is not more than a diameter of said impression cylinder (12).

5

10

15

20

25

30

35

40

45

50

55

5

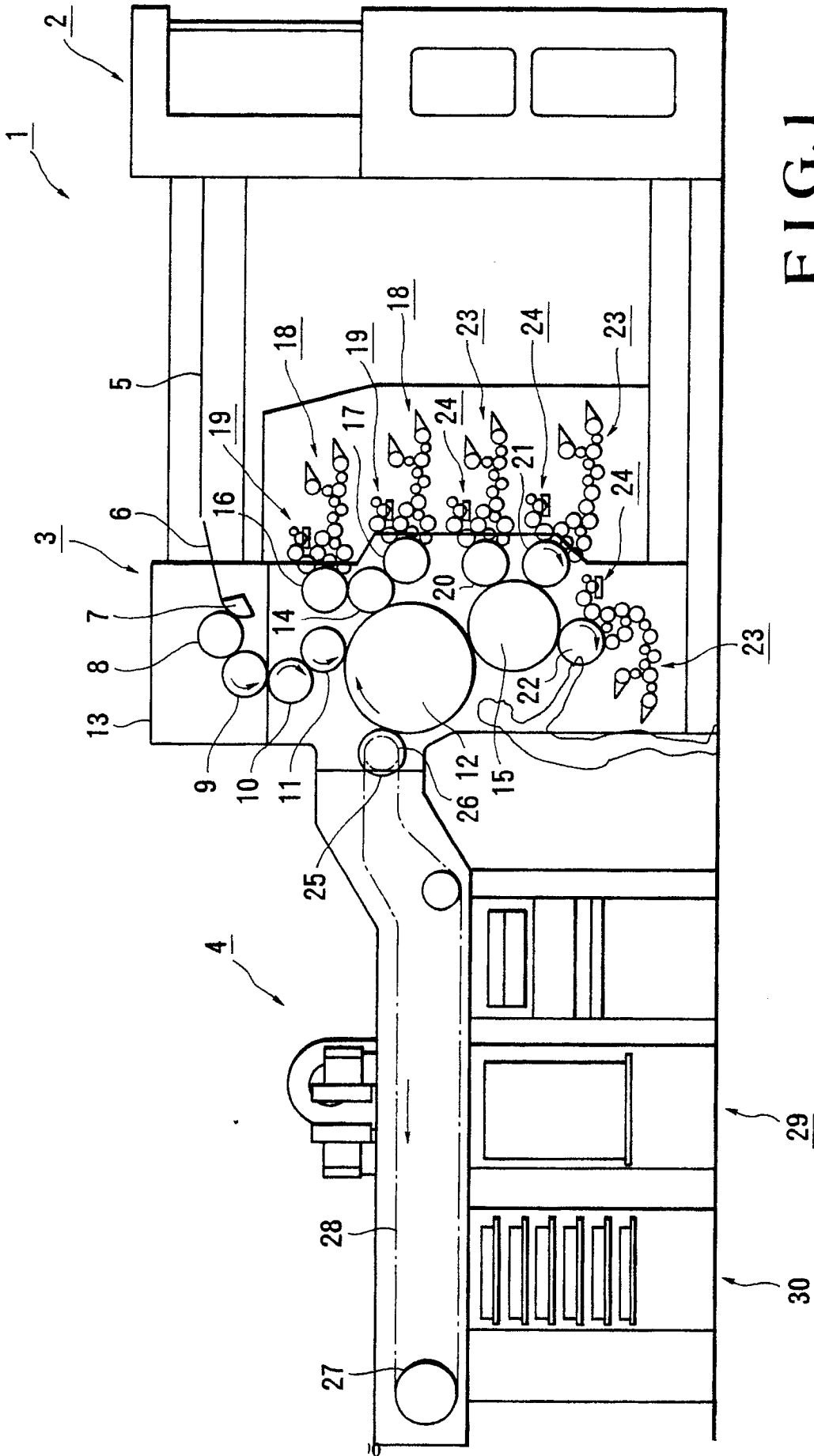

FIG. 1

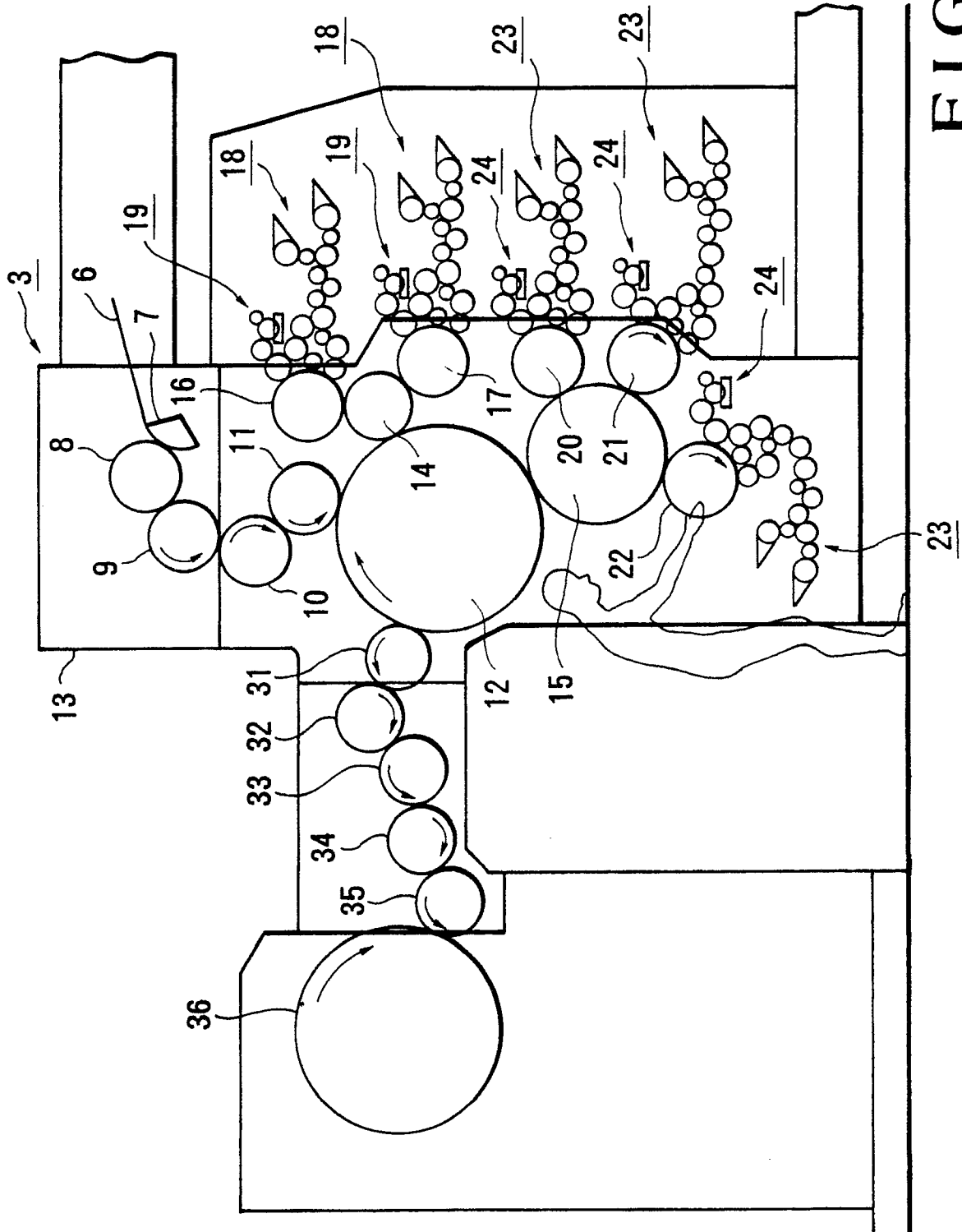

FIG.2

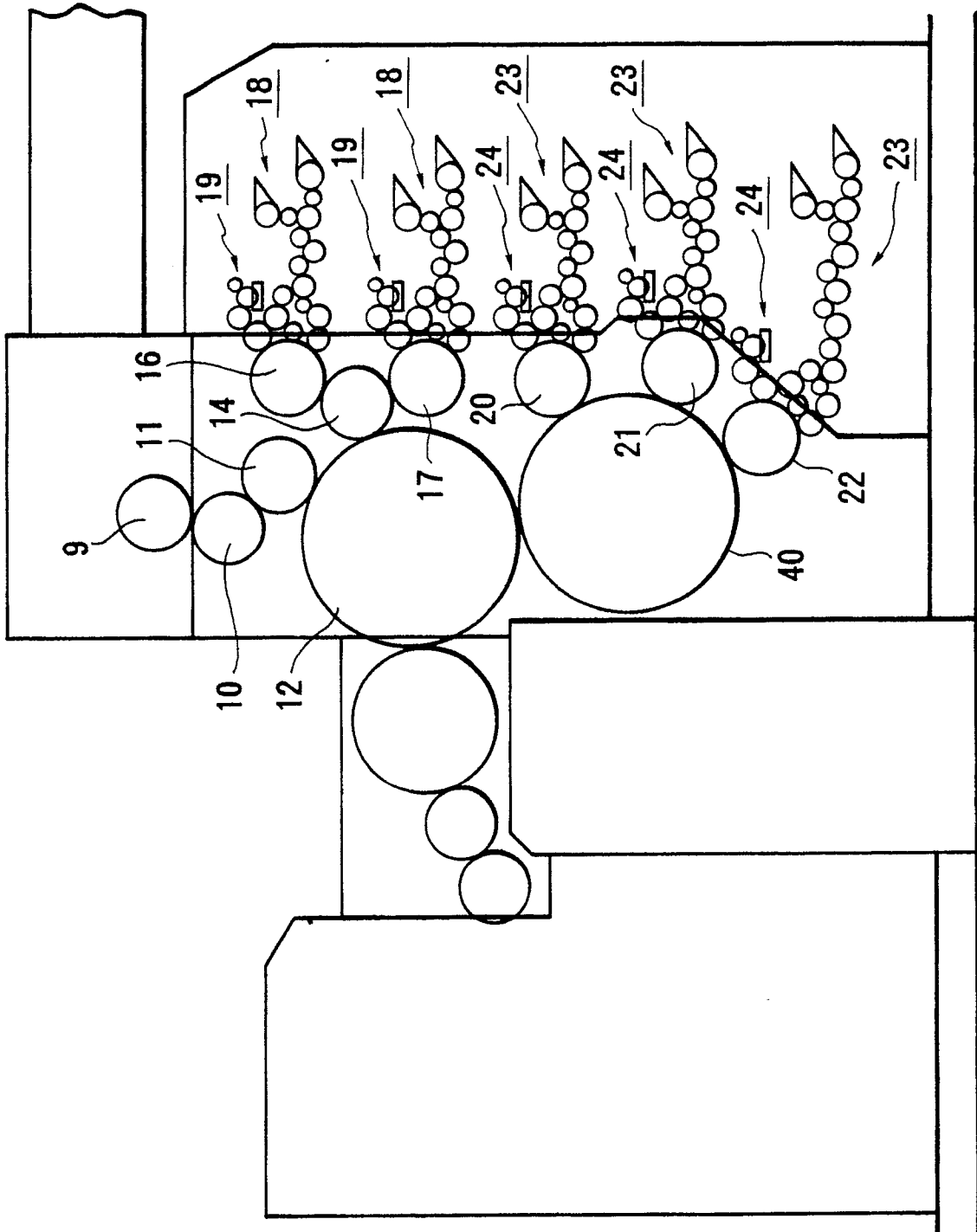

FIG.3

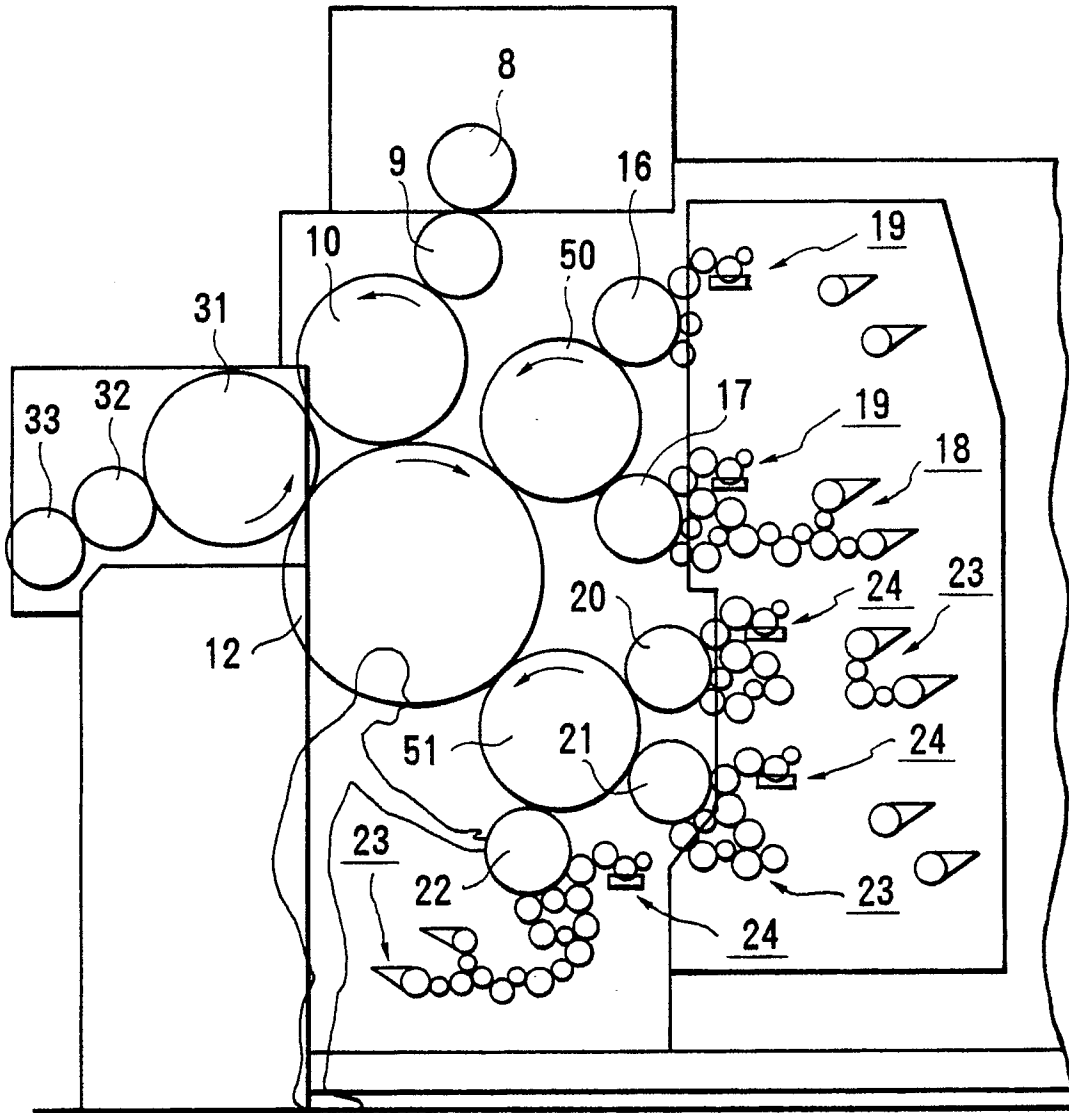

FIG.4

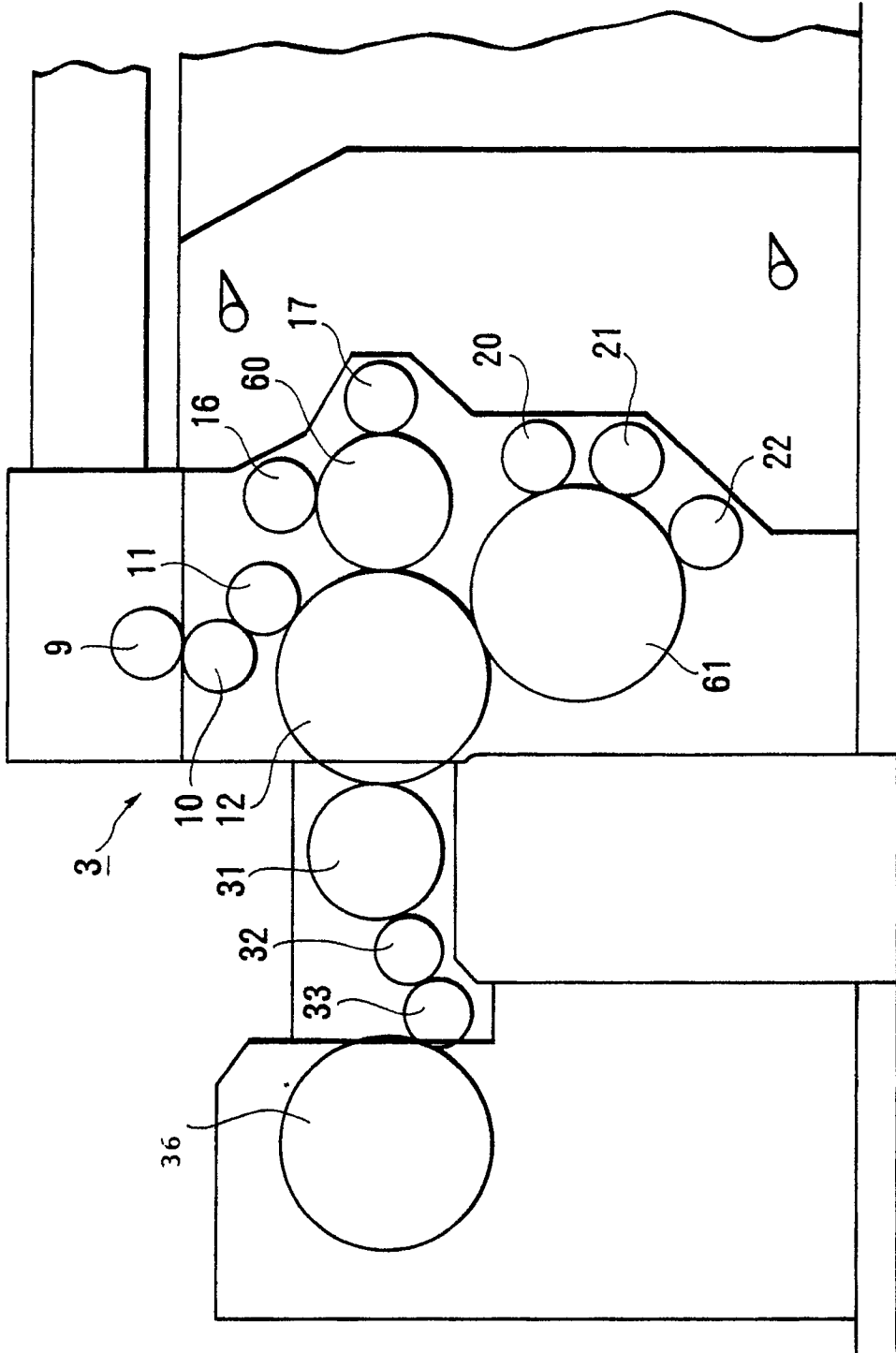

FIG.5