

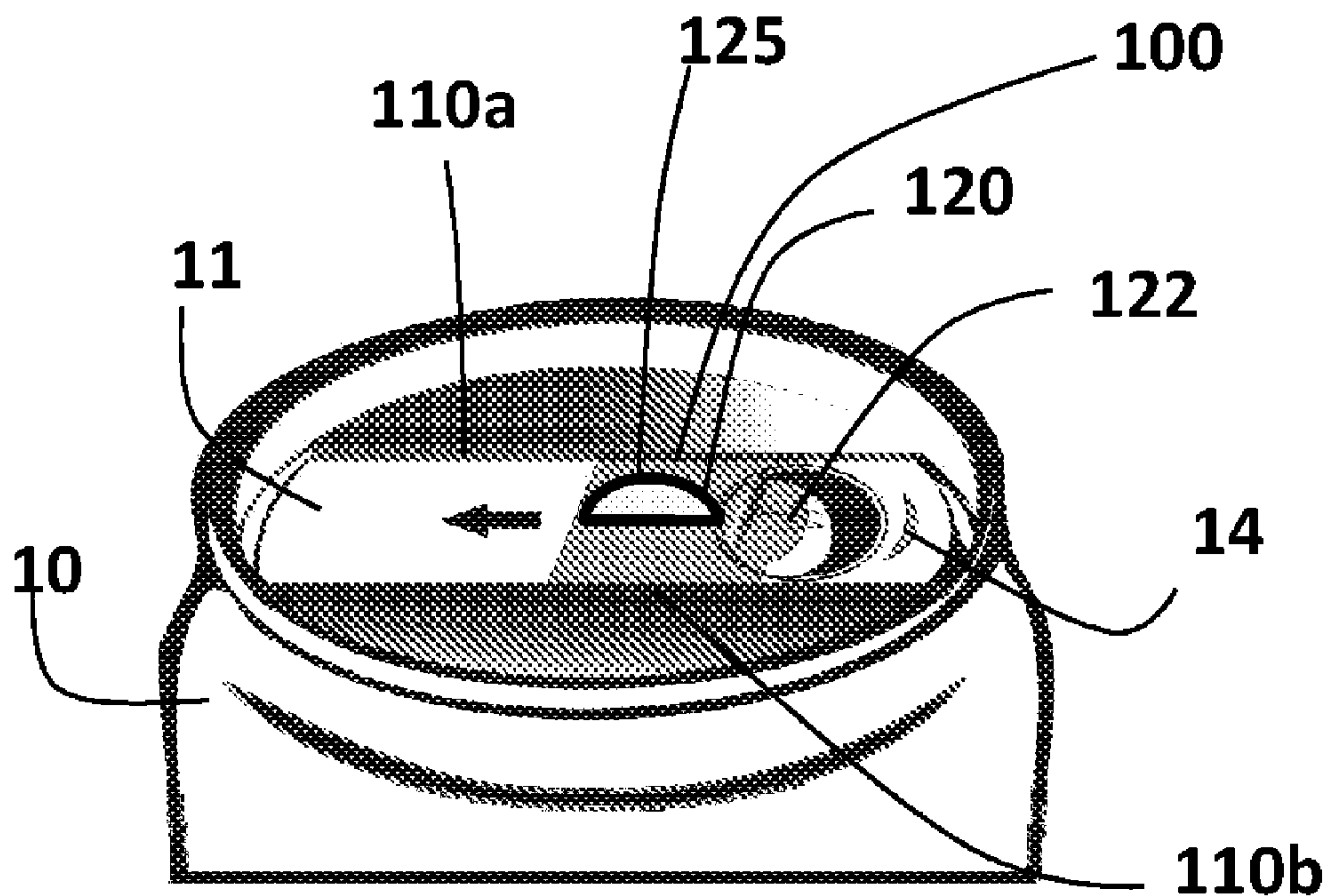

(86) **Date de dépôt PCT/PCT Filing Date:** 2016/02/16  
 (87) **Date publication PCT/PCT Publication Date:** 2016/08/25  
 (45) **Date de délivrance/Issue Date:** 2019/07/09  
 (85) **Entrée phase nationale/National Entry:** 2017/08/11  
 (86) **N° demande PCT/PCT Application No.:** IB 2016/050815  
 (87) **N° publication PCT/PCT Publication No.:** 2016/132287  
 (30) **Priorités/Priorities:** 2015/02/17 (US14/623,742);  
 2015/07/15 (US14/799,868)

(51) **Cl.Int./Int.Cl. B65D 51/20** (2006.01),  
**B65D 51/22** (2006.01), **B65D 53/00** (2006.01)  
 (72) **Inventeur/Inventor:**  
 DABBUR, ISMAIL OMAR, IL  
 (73) **Propriétaire/Owner:**  
 SEALTAP GMBH, CH  
 (74) **Agent:** NELLIGAN O'BRIEN PAYNE LLP

(54) **Titre : MECANISME DE SECURITE POUR CONTENANTS**  
 (54) **Title: SAFETY MECHANISM FOR CONTAINERS**



(57) **Abrégé/Abstract:**

A container top comprising a container top member comprising tracks (110a, 110b) over an upper surface thereof and a sealer sealing an opening thereof; and a slidable member (120) having a sealing mechanism, the slidable member being slidable through the tracks and positioned such that sliding of the slidable member over the tracks to one direction unseals the sealer (12), forming an opening over the container top member, in the initial opening thereof and wherein sliding the slidable member back to its original position over the opening formed thereby covers and seals the opening. The opening formed by the unsealing of the sealer can be re-sealed at will by the sealing mechanism of the slidable member. The sealing mechanism may be for example a sealing material coating strip located over a periphery of the slidable member (120) or the physical configuration of the slidable member periphery edges.

(12) INTERNATIONAL APPLICATION PUBLISHED UNDER THE PATENT COOPERATION TREATY (PCT)

(19) World Intellectual Property  
Organization  
International Bureau(10) International Publication Number  
**WO 2016/132287 A1**(43) International Publication Date  
25 August 2016 (25.08.2016)(51) International Patent Classification:  
*B65D 17/00* (2006.01)(21) International Application Number:  
PCT/IB2016/050815(22) International Filing Date:  
16 February 2016 (16.02.2016)

(25) Filing Language: English

(26) Publication Language: English

(30) Priority Data:  
14/623,742 17 February 2015 (17.02.2015) US  
14/799,868 15 July 2015 (15.07.2015) US(71) Applicant: SEALTAP GMBH [CH/CH]; c/o RETREAG  
REVISIONS AG, Lueberenstrasse 47, 6301 Zug (CH).(72) Inventor: DABBUR, Ismail Omar; P.O box 5820, Man-  
zel-Elnour st., 1695500 Jaffa of Nazareth (IL).(81) Designated States (unless otherwise indicated, for every  
kind of national protection available): AE, AG, AL, AM,  
AO, AT, AU, AZ, BA, BB, BG, BH, BN, BR, BW, BY,  
BZ, CA, CH, CL, CN, CO, CR, CU, CZ, DE, DK, DM,DO, DZ, EC, EE, EG, ES, FI, GB, GD, GE, GH, GM, GT,  
HN, HR, HU, ID, IL, IN, IR, IS, JP, KE, KG, KN, KP, KR,  
KZ, LA, LC, LK, LR, LS, LU, LY, MA, MD, ME, MG,  
MK, MN, MW, MX, MY, MZ, NA, NG, NI, NO, NZ, OM,  
PA, PE, PG, PH, PL, PT, QA, RO, RS, RU, RW, SA, SC,  
SD, SE, SG, SK, SL, SM, ST, SV, SY, TH, TJ, TM, TN,  
TR, TT, TZ, UA, UG, US, UZ, VC, VN, ZA, ZM, ZW.(84) Designated States (unless otherwise indicated, for every  
kind of regional protection available): ARIPO (BW, GH,  
GM, KE, LR, LS, MW, MZ, NA, RW, SD, SL, ST, SZ,  
TZ, UG, ZM, ZW), Eurasian (AM, AZ, BY, KG, KZ, RU,  
TJ, TM), European (AL, AT, BE, BG, CH, CY, CZ, DE,  
DK, EE, ES, FI, FR, GB, GR, HR, HU, IE, IS, IT, LT, LU,  
LV, MC, MK, MT, NL, NO, PL, PT, RO, RS, SE, SI, SK,  
SM, TR), OAPI (BF, BJ, CF, CG, CI, CM, GA, GN, GQ,  
GW, KM, ML, MR, NE, SN, TD, TG).

Published:

- with international search report (Art. 21(3))
- before the expiration of the time limit for amending the  
claims and to be republished in the event of receipt of  
amendments (Rule 48.2(h))

(54) Title: SAFETY MECHANISM FOR CONTAINERS

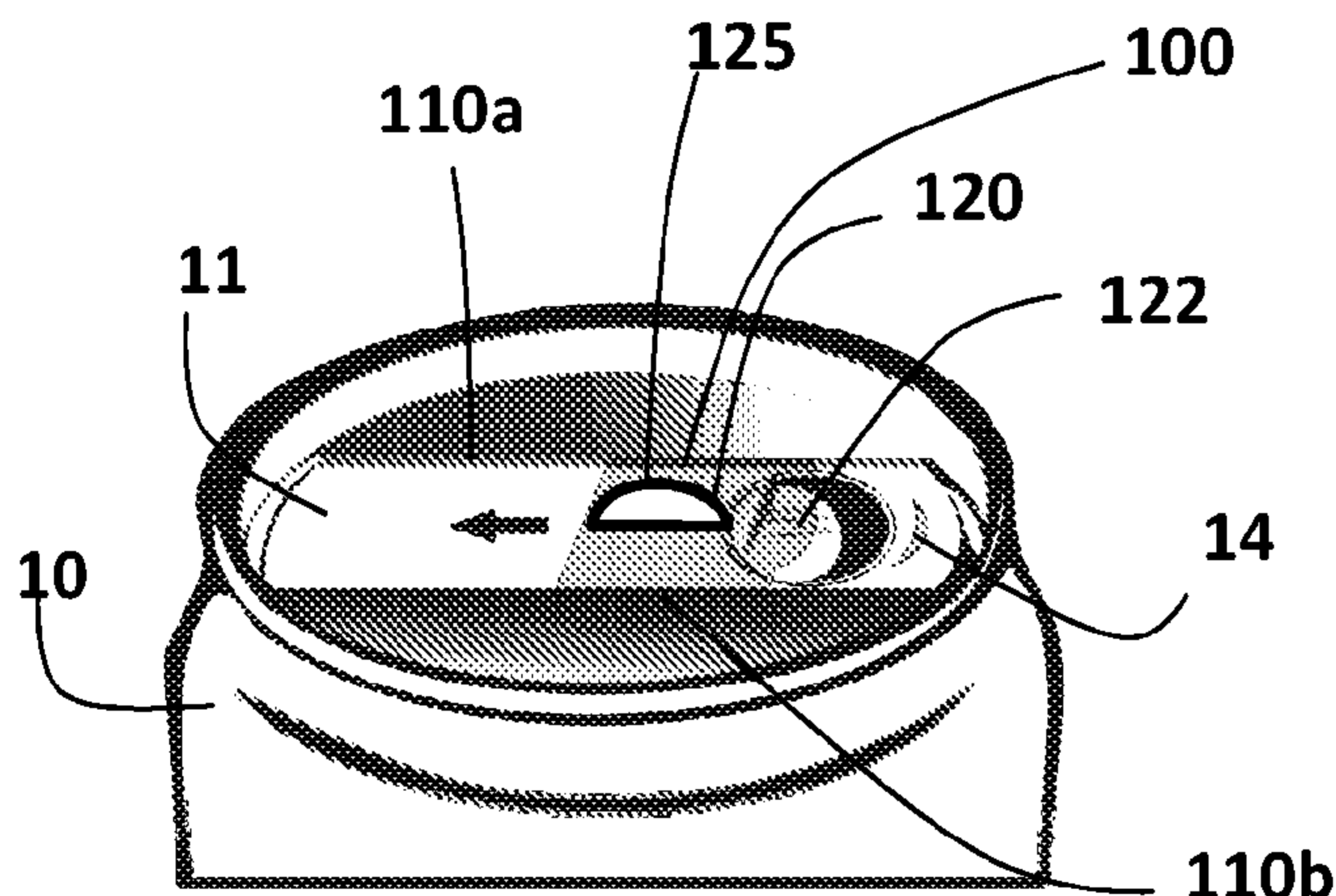

Fig. 1D

(57) Abstract: A container top comprising a con-  
tainer top member comprising tracks (110a, 110b)  
over an upper surface thereof and a sealer sealing  
an opening thereof; and a slidable member (120)  
having a sealing mechanism, the slidable member  
being slidable through the tracks and positioned  
such that sliding of the slidable member over the  
tracks to one direction unseals the sealer (12),  
forming an opening over the container top mem-  
ber, in the initial opening thereof and wherein  
sliding the slidable member back to its original  
position over the opening formed thereby covers  
and seals the opening. The opening formed by the  
unsealing of the sealer can be re-sealed at will by  
the sealing mechanism of the slidable member.  
The sealing mechanism may be for example a  
sealing material coating strip located over a peri-  
phery of the slidable member (120) or the physical  
configuration of the slidable member periphery  
edges.

## **SAFETY MECHANISM FOR CONTAINERS**

### **FIELD OF THE INVENTION**

[0001] The present invention generally relates to mechanisms for sealing containers and more particularly to mechanisms for safety sealing and covering of containers allowing repeatable covering and opening of a container's opening especially yet not exclusively for food and beverages containers.

### **BACKGROUND OF THE INVENTION**

[0002] Manufacturers of food and beverage cans typically use pull-tab sealing and opening mechanism or stay-on tabs, in which a tab is used to tear off the can top (full aperture end) or designated part thereof for leaving an opening at the can top. In the pull tab mechanism the tab is removed from the can whereas in the stay-on tab the tab remains after the opening is revealed.

[0003] Other solutions involve press button mechanisms, in which a designated opening in the can upper face is sealed by using soft connection of the sealer to the opening rim requiring pressing the softly connected seal downwards towards the inner space of the can for opening thereof.

[0004] These solutions are vulnerable to unauthorized penetration to the inner cavity of the containers after filling and sealing thereof by the manufacturer and enable insertion of materials into the containers while covering any trace of the penetration. For example, in the case of the pull-tab or stay-on tab sealing the tab connects to the top of the container usually through a connecting stud and can be easily rotated around the stud axis revealing some of the upper surface exposed for injecting a material into the can or even replacing the liquid in the can with a different liquid and covering the area of the penetration hole by rotating the tab back to its position again. In this way the user of the can cannot see that the can was "treated" and might innocently use it for drinking or for eating the food content thereof.

### **SUMMARY OF THE INVENTION**

[0005] The present invention provides a container top comprising a container top member comprising tracks over an upper surface thereof and a sealer sealing an opening thereof; and a slidable member having a sealing mechanism, the slidable

member being slidable through the tracks and positioned such that sliding of the slidable member over the tracks to one direction unseals the sealer, forming an opening over the container top member, in the initial opening thereof and wherein sliding the slidable member back to its original position over the opening formed thereby covers and seals the opening. The opening formed by the unsealing of the sealer can be re-sealed at will by the sealing mechanism of the slidable member. The sealing mechanism may be for example a sealing material coating strip located over a periphery of the slidable member or the physical configuration of the slidable member periphery edges.

10 **[0006]** According to some embodiments, the sealing mechanism comprises a sealing coating strip or sealing material strip connected to a lower periphery of the slidable member.

**[0007]** According to some embodiments, the slidable member periphery is curved such as to allow engagement thereof with the tracks and upper surface of the container top for sealing thereof. The slidable member periphery curving, in some embodiments, forms an angle fit to have the periphery edge to engage the tracks.

15 **[0008]** According to some embodiments, the sealer has a sloped protruding shape and the slidable member has a complimentary sloped protrusion configured for fitting to the sealer for covering the sealer in the initial sealed position and pushing thereof inwardly towards the interior of the can for opening thereof.

**[0009]** The slidable member may further comprise at least one protruding stripe.

**[0010]** The container top according to claim 1, wherein said tracks and sealer are produced through punch pressing. According to some embodiments, the sealer is a press button sealer configured for sealing the opening of the container by loosely connecting to the edges of said opening.

20 **[0011]** The container top is optionally configured for sealably attaching thereof to a container body containing a material therein.

**[0012]** The present invention further provides a sealing and safety mechanism for a can container positionable over a container top and part thereof, the mechanism comprising: at least two tracks positioned over an upper surface of the container top; a sealer sealing an opening over the container top; and a slidable member having a sealing mechanism, the slidable member being slidable through the tracks and positioned such that sliding of the slidable member over the tracks to one direction

unseals the sealer, forming an opening over the container top member, in the initial opening thereof and wherein sliding the slidable member back to its original position over the opening formed thereby covers and seals the opening.

### **BRIEF DESCRIPTION OF THE DRAWINGS**

5 **[0013]** **Figures 1A-1F** schematically illustrate a safety cover mechanism for a conical can container having a press button sealer, wherein the safety cover mechanism has a slidable member slidable over designated tracks, according to some embodiments of the present invention: **Fig. 1A** shows a perspective view of the can having a press button sealer and the tracks of the safety cover mechanism formed by punch pressing  
10 of the upper surface part of the can; **Fig. 1B** shows a perspective view of the can and the slidable member of the safety cover mechanism in a closed position in which the slidable covers the press button of the can; **Fig. 1C** shows a perspective view of the can and safety cover mechanism, wherein the slidable member is in a semi-closed position slightly pushing the press button inwardly towards the inner cavity of the can for  
15 detaching part thereof to allow opening thereof; **Fig. 1D** shows a perspective view of the can and safety cover mechanism, wherein the slidable member is in a semi-closed position further pushing the press button inwardly towards the inner cavity of the can for detaching part thereof to allow opening thereof; **Fig. 1E** shows a perspective view of the can and safety cover mechanism, wherein the slidable member is in an open  
20 position in which the press button of the can is completely pressed inwardly leaving an open hole at the can upper face; and **Fig. 1F** shows a cross sectional view of the upper part of the can with the slidable member shown inside the tracks of the safety cover mechanism.

**[0014]** **Figures 2A-2E** schematically illustrate a safety cover mechanism for a  
25 conical can container, wherein the safety cover mechanism has a slidable member slidable over protruding tracks and a flexible sealer for sealing an opening of the can and for covering part of the can top rim that is designated for contacting the mouth of a person drinking from the can for improving hygiene, according to other embodiments of the present invention: **Fig. 2A** shows a perspective view of the can and safety cover  
30 mechanism, in which the slidable member and the flexible sealer are in a sealed closed position covering the press button that seals the opening of the can; **Fig. 2B** shows a perspective view of the can and the safety cover mechanism, wherein the slidable

member is slid backwards to reveal the flexible sealer and the flexible sealer is in a covering position in which it covers the can top rim part; **Fig. 2C** shows a perspective view of the can and the safety cover mechanism, wherein the slidable member is in an open position and the flexible sealer is slightly lifted revealing that the press button of the can is fully pushed inwardly opening the can top hole; **Fig. 2D** shows a perspective view of the can and the safety cover mechanism, wherein the slidable member is in a fully open position and the flexible sealer is fully removed; and **Fig. 2E** shows a cross sectional view of the upper part of the can with the slidable member shown inside the tracks of the safety cover mechanism.

10 **[0015]** **Figures 3A-3E** schematically illustrate a safety cover mechanism for a conical can container having a press button sealer, wherein the safety cover mechanism has a slidable member slidable over protruding tracks, according to other embodiments of the present invention: **Fig. 3A** shows a perspective view of the can and safety cover mechanism, in which the slidable member is in a closed position covering  
15 the press button sealer that seals the opening of the can; **Fig. 3B** shows a perspective view of the can and the safety cover mechanism, wherein the slidable member is in a semi-open position slightly pushing the press button sealer inwardly into the can; **Fig. 3C** shows a perspective view of the can and the safety cover mechanism, wherein the slidable member is in a fully open position and the press button is fully inserted into the  
20 can or dropped therein; **Fig. 3D** shows a perspective view of the slidable member of the safety cover mechanism; and **Fig. 3E** shows a cross sectional view of the upper part of the can with the slidable member shown inside the tracks of the safety cover mechanism.

**[0016]** **Figures 4A-4E** schematically illustrate a safety cover mechanism for a  
25 conical can container, wherein the safety cover mechanism has a slidable member slidable over tracks formed over the can upper face and a flexible sealer for sealing an opening of the can and for covering part of the can top rim that is designated for contacting the mouth of a person drinking from the can for improving hygiene, according to other embodiments of the present invention: **Fig. 4A** shows a perspective  
30 view of the can and safety cover mechanism, in which the slidable member and flexible sealer are in closed position; **Fig. 4B** shows a perspective view of the can and the safety cover mechanism wherein the slidable member is in an open position and the flexible sealer is in a closed position; **Fig. 4C** shows a perspective view of the can

and the safety cover mechanism, wherein the slidable member is in an open position and the flexible sealer is slightly lifted to remove thereof for using the can for drinking therefrom; **Fig. 4D** shows a perspective view of the can and the safety cover mechanism, wherein the slidable member is in a fully open position and the flexible sealer is fully removed; and **Fig. 4E** shows a cross sectional view of the upper part of the can with the slidable member shown inside the tracks of the safety cover mechanism.

**[0017]** **Figures 5A-5G** schematically illustrate a safety cover mechanism for a conical can container having a flexible sealer, wherein the safety cover mechanism has a slidable member slidable over designated tracks, according to some embodiments of the present invention: **Fig. 5A** shows a perspective view of the can and safety cover mechanism, wherein the tracks of the safety cover mechanism protrude from the upper surface part of the can; **Fig. 5B** shows a perspective view of the can and the flexible sealer of the safety cover mechanism in a closed position in which the flexible sealer seals the opening of the can and covers a rim portion thereof designated to be in contact with a user's lips from drinking beverage content of the can; **Fig. 5C** shows a perspective view of the can and safety cover mechanism, wherein the slidable member is in a semi-closed position slightly tearing off a softly connected sealing part of the flexible sealer; **Fig. 5D** shows a perspective view of the can and safety cover mechanism, wherein the slidable member is in a fully open position revealing the sealing opening of the flexible sealer while maintaining part of the sealer over the can rim portion that is to be in contact with the user's lips; **Fig. 5E** shows a perspective view of the can and safety cover mechanism, wherein the slidable member is in an open position and the flexible sealer is semi-removed at least from the rim portion it covered; **Fig. 5F** shows a perspective view of the can and safety cover mechanism in a fully open position with the flexible sealer fully removed therefrom; and **Fig. 5G** shows a cross sectional view of the upper part of the can with the slidable member shown inside the tracks of the safety cover mechanism.

**[0018]** **Figures 6A-6C** show a safety mechanism for food or beverage containers such as a can, which is designed to prevent rotation of a pull or stay-on tab of the can, which includes two protrusions protruding from the can upper face and located at opposite sides of the tab, according to one embodiment of the invention: **Fig. 6A** shows a top view of the can and safety mechanism; **Fig. 6B** shows a cross sectional side view

of the can and safety mechanism; and **Fig. 6C** shows a perspective view of the can and safety mechanism.

**[0019]** **Fig. 7** shows a safety mechanism for preventing rotation of a pull tab of a can, which includes a single pin fastening the tab to the upper face part of the can,  
5 according to an alternative embodiment of the invention.

**[0020]** **Fig. 8** shows a safety mechanism for preventing rotation of a pull tab of a can, which includes a fastener fastening the pull tab and the cover of the can, according to another embodiment of the invention.

**[0021]** **Fig. 9** shows a safety mechanism for preventing rotation of a pull tab of a  
10 can, which includes two protrusions, located at opposite sides of the pull tab, according to yet another embodiment of the invention.

**[0022]** **Figures 10A-10D** show a can top with a safety mechanism for a container such as a beverage can, which also allows sealing the can opening after its press button sealer has been opened, wherein the post-opening sealing is done by adding a sealing  
15 strip such as a silicon strip to the bottom edge of the slidable member, according to some embodiments of the invention: **Fig. 10A** shows a perspective exploded view of the safety mechanism integrated with the can top; **Fig. 10B** shows a bottom perspective view of the slidable member of the safety mechanism; **Fig. 10C** shows a bottom view of the can top with the sealer push button and tracks integrated therein; and **Fig. 10D**  
20 shows a can having the can top thereover, wherein the slidable member and sealer are in a semi-open position .

**[0023]** **Figures 11A-11F** show a can top with a safety mechanism for a container such as a beverage can, which also allows sealing the can opening after its press button sealer has been opened, wherein the post-opening sealing is enabled by the  
25 configuration of the slidable member edges having a curved shape fit to mesh and contact the tracks through at least a meshing and contacting line or surface, according to other embodiments of the invention: **Fig. 11A** shows a perspective exploded view of the safety mechanism integrated with the can top; **Fig. 11B** shows a perspective elevated view of the slidable member of the safety mechanism also serving as a sealer;  
30 **Fig. 11C** shows an elevated bottom view of the slidable member; **Fig. 11D** shows an elevated view of the slidable member indicating a position for cross-section cutting DD; **Fig. 11E** shows a sectional view of DD ; **Fig. 11F** shows a zoom-in area E of the cross sectional view DD of the safety mechanism; **Fig. 11G** shows a cross sectional

view of the entire beverage can with the safety mechanism thereof ; **Fig. 11H** shows a zoom-in area I of the can with safety mechanism shown in **Fig. 11H**; and **Fig. 11I** shows a zoom-n view of area J indicated in **Fig. 11H**.

## 5 **DETAILED DESCRIPTION OF SOME EMBODIMENTS OF THE INVENTION**

**[0024]** In the following detailed description of various embodiments, reference is made to the accompanying drawings that form a part thereof, and in which are shown by way of illustration specific embodiments in which the invention may be practiced. It is understood that other embodiments may be utilized and structural changes may be made without departing from the scope of the present invention.

**[0025]** The present invention, in some embodiments thereof, provides a safety cover mechanism for containers such as food or beverages cans or any other container. The safety cover mechanism is designed to prevent unauthorized and unnoticed penetration to the inner cavity of the container by only enabling accessing the content of the container through the mechanism, which will always leave a visible trace to the opening or any other treatment thereof.

**[0026]** According to some embodiments, the safety cover mechanism comprises at least one track positionable over a top part of the container in proximity to an opening thereof, which may be sealed by a sealer softly connected to edges of the opening; and a slidable member slidable over the at least one track such as to allow covering and revealing the container opening by sliding the slidable member along the one or more tracks. The one or more tracks may be designed as an integral part of the container top or connected thereto. The slidable and track design does not enable any part of the upper surface of the container to be exposed and then constantly covered during opening of the container, since the slidable has to be moved along the one or more tracks for repeatedly revealing and covering the opening thereof. This leaves out the pull or stay-on tab solutions which allow some of the surface of the container to be exposed and then re-covered again for concealing the penetration hole.

**[0027]** In some embodiments, the slidable member also allows opening the sealer of the can top for revealing the opening thereof to allow access to the container's content, e.g. in case of beverage can container with a press button sealer the slidable is placed over the press button and when first slid back along the tracks it also presses the

button inwardly into the can cavity for opening thereof by having a section that protrudes inwardly at one end thereof.

[0028] Reference is now made to **Figures 1A-1F** showing a safety cover mechanism **100** over an upper surface **11** of a can **10** container, according to one  
5 embodiment of the invention. The safety cover mechanism **100** in this embodiment includes a slidable member **120** and two tracks **110a** and **110b** formed by punch pressing of the upper surface **11** part of the can **10**. The slidable member **120** is inserted and slid through those tracks **110a** and **110b**. The can **10** may be made of aluminum or aluminum alloy or any other material known in the art for can production.

10 [0029] The can **10** has an opening **15** (**Fig. 1E**) over its upper surface **11** sealed by a press button sealer **12**, which is a piece that connects to the rim of the opening **15** by a soft connection that can be easily open once applying pressure inwardly over the sealer **12**.

[0030] According to some embodiments, as shown in **Figures 1A-1E**, the upper  
15 surface **11** of the can **10** may include a recess stopper **14** also formed by punch pressing, for preventing the slidable member **120** from exceeding thereof when slid through the tracks **110a** and **110b**.

[0031] The slidable member **120** has a protrusion **121** for comfort sliding thereof and a folded edge part **122** (see **Fig. 1E**) that folds inwardly towards the upper surface  
20 **11** of the can **10** for being blocked by the recess stopper **14** and also for enabling pressing the press button sealer **12** inwardly at the first opening of the can **10** when the slidable member **120** is slid thereover.

[0032] The design of the slidable member **120** over the opening of **15** of the can **10** allows revealing and covering thereof at will repeatedly by sliding the slidable member  
25 **120** back and forth over the tracks **110a** and **110b**.

[0033] According to some embodiments, as shown in **Figures 1A** and **1E**, the press button sealer **12** also has a protrusion **13** that engages the folded edge part **122** of the slidable member **120** for pressing the sealer **12** inwardly when the slidable member **120** is slid thereover. The slidable member **120** also includes an elevated niche **125** fit to  
30 interlock with the protrusion **13** when the sealer **12** is in its un-open position before opening of the can **10**.

[0034] As shown in **Fig. 1F**, the upper surface **11** of the can **10** is convex in a substantially symmetric manner such that the highest point or area is located

substantially at the center of the upper surface **11**. Therefore, the tracks **110a** and **110b** formed over the upper surface **11** of the can **10** are also convex requiring the slidable member **120** to be configured in a corresponding curvature or be flexible enough to allow sliding thereof over the curved tracks **110a** and **110b**. In this way, since the opening **15** is located offset from the center of the upper surface **11**, the slidable member **120** passes thereof while declining from the highest area of the upper surface **11** allowing further pressing the press button **12** inwardly thereby.

**[0035]** Reference is now made to **Figures 2A-2E** showing a safety cover mechanism **200** installed over an upper face **21** of a can **20** container, according to another embodiment of the invention. The safety cover mechanism **200** in this embodiment includes a slidable member **220** and two tracks **210a** and **210b** over which the slidable member **220** is slid. Each of the tracks **210a** and **210b** is either integrally or non-integrally connected over the upper surface **21** of the can **20** and may be made from any rigid or semi-rigid material known in the art such as plastic, aluminum, alloy and the like. The can **20** may be made of aluminum or aluminum alloy or any other material known in the art for can production. The slidable member **220** has a protrusion **221** for comfort sliding thereof.

**[0036]** As shown in **Figures 2A-2C**, the safety cover mechanism **200** further includes a flexible sealer **230** that is attached or placed between the opening **22** of the can **20** and the slidable member **220** and serves as a sealer for the can **20** opening **22**. The flexible sealer **230** is designed to cover a portion of the top rim of the can **20** that would contact the user's mouth when drinking from the can **20**. Before the first opening of the can **20** the slidable member **220** is slid backwards towards the distal rim of the can top in respect to the opening thereof and thereby also pulls the flexible sealer **230** to reveal the opening **22** flexible sealer of the can **20**. Once the slidable member **220** is in a fully open position and the opening **22** is fully revealed (see **Fig. 2D**) the flexible sealer **230** can be removed by pulling thereof leaving only the slidable member **220** and tracks **210a** and **210b** over the can top side **21** for repeatable covering and revealing of the opening **22** (see **Fig. 2D**). Alternatively, the flexible sealer **230** is remained attached at one end thereof to the upper surface **21** of the can **20** for re-sealing of the opening **22** upon covering thereof by the slidable member **220**.

**[0037]** The slidable member **220** has no inwardly folded portion at its edge in this embodiment and the tracks **210a** and **210b** edges **215a** and **215b** are inwardly curved to

serve as stoppers for preventing the slidable member **220** from exceeding thereof when slid backwards.

**[0038]** As shown in **Fig. 2E**, the upper surface **21** of the can **20** is convex in a substantially symmetric manner such that the highest point or area is located  
5 substantially at the center of the upper surface **21**. Therefore, the tracks **210a** and **210b** formed over the upper surface **21** of the can **20** are also convex requiring the slidable member **220** to be configured in a corresponding curvature or be flexible enough to allow sliding thereof over the curved tracks **210a** and **210b**.

**[0039]** As shown in **Fig. 2A**, the safety cover mechanism **200** may also include  
10 frontal slidable stoppers such as stoppers **228a** and **228b** loosely attached to the slidable member **220** and covering the edges of the tracks **110a** and **110b**. Any slight sliding movement of the slidable member **220** backwards will cause these stoppers **228a** and **228b** to tear their loose holding to the slidable member **220** since they block the backwards movement thereof and since they are loosely connected thereto. This  
15 will allow identification of the sliding of the slidable member **220** for security purposes.

**[0040]** Reference is now made to **Figures 3A-3F** showing a safety cover mechanism **300** installed over an upper face **31** of a can **30** container, according to yet another embodiment of the invention. The safety cover mechanism in this embodiment  
20 includes a slidable member **320** and two protruding tracks **310a** and **310b** over which the slidable member **320** is slidable. Each of the tracks **310a** and **310b** connects to a rim part of the can upper surface **31**. The can **30** may be made of aluminum or aluminum alloy or any other material known in the art for can production. The can **30** has an opening over its upper face **31** sealed by a press button sealer **32**.

**[0041]** According to some embodiments, as shown in **Figures 3A-3D**, the upper  
25 face **31** of the can **30** may include a recess stopper **34** (**Fig. 3C**) for preventing the slidable member **320** from exceeding thereof.

**[0042]** The slidable member **320** has a protrusion **321** for comfort sliding thereof and a folded edge part **323** (see **Fig. 3D**) that folds inwardly towards the upper face **31**  
30 of the can **30** for enabling pressing the press button sealer **32** inwardly at the first opening of the can **30**.

**[0043]** According to some embodiments, as shown in **Figures 3A-3B**, the press button sealer **32** also has a protrusion **33** that engages the folded edge part **323** of the

slidable member **320** for allowing the folded edge part **323** to engage the protrusion **33** for pressing the sealer **32** inwardly towards the can **30** inner cavity.

**[0044]** Additionally, as shown in **Figures 3A-3D**, the slidable member **320** upper surface has an elevated niche **322** configured to interlock with the protrusion **33** of the press button sealer **32** when in its pre-open position before first opening of the can **30**.

**[0045]** As shown in **Fig. 3E**, the upper surface **31** of the can **30** is convex in a substantially symmetric manner such that the highest point or area is located substantially at the center of the upper surface **31**. Therefore, the tracks **310a** and **310b** formed over the upper surface **31** of the can **30** are also convex requiring the slidable member **320** to be configured in a corresponding curvature or be flexible enough to allow sliding thereof over the curved tracks **310a** and **310b**.

**[0046]**

**[0047]** Reference is now made to **Figures 4A-4E** showing a safety cover mechanism installed over an upper face **41** of a can **40** container, according to yet another embodiment of the invention. The safety cover mechanism **400** in this embodiment includes a slidable member **420**, a flexible sealer **430** and two tracks **410a** and **410b** formed by punch pressing of the upper surface **41** part of the can **40**.

**[0048]** The can **40** has an opening **42** over its upper surface **41** sealable by the flexible sealer **430** of the safety cover mechanism **400**.

**[0049]** The slidable member **420** has a protrusion **421** for comfort sliding thereof.

**[0050]** As shown in **Figures 4A-4C**, the flexible sealer **430** is attached or placed between the opening **42** of the can **40** and the slidable member **420** and serves as a sealer of the opening **42** as well as a hygiene element for preventing exposure of the part of the can **40** rim that is designated to be in contact with a user's lips during storage and transport of the can **40**. The flexible sealer **430** is removable from that rim part of the can **40** only upon first opening thereof and can then be either completely removed from the can **40** or reused for re-sealing of the can opening **42** by connecting still to the can surface **41** at one end thereof.

**[0051]** Reference is now made to **Figures 5A-5G**, schematically illustrating a safety cover mechanism **500**, according to another embodiment of the invention. In this embodiment the safety cover mechanism **500** includes a slidable member **520**, two protruding tracks **510a** and **510b** located over the upper surface **51** of a beverage can **50** and a flexible sealer **530** having a designated sealing portion **531** that loosely

connects thereto for easy opening thereof, when the slidable member **520** is slid over the tracks **510a** and **510b**. The tracks **510a** and **510b** have curved edges **515a** and **515b** serving as stoppers for preventing the slidable member **520** from exceeding thereof when slid opposite to the can opening **54**.

5 **[0052]** According to some embodiments, the flexible sealer **530** covers a rim portion of the can **50** designated to be in contact with a user's lips when drinking for hygienic purposes. Additionally, as shown in **Figures 5C-5D**, once the slidable member **520** is slid backwards, away from the location of the opening **54** of the can, the loosely connected portion **531** of the flexible sealer **530** tears due to the pressure  
10 applied thereover by an inwardly protruding folded edge **522** of the slidable member **520**. The slidable member **520** may also include a protrusion **521** for easy sliding thereof.

**[0053]** The safety cover mechanism as described above or in any other embodiment of this invention is designed such that when the slidable member is even  
15 slightly slid away from the location of the opening of the container in the first opening of the container this slight sliding movement thereof will cause the sealer (either the press button sealer, flexible sealer or any other sealer design) to be at least partially unsealed in a manner that will not allow reconnecting thereof. This means that once the slidable member is slightly slid through the tracks to open, it will indicate to the user  
20 that the can was opened after the manufacturer had sealed it at least to some extent. This configuration is targeted at preventing unauthorized penetration into the container's inner content for preventing felonious penetration of materials after the can has been sealed by the manufacturer.

**[0054]** The present invention further provides a safety mechanism for containers  
25 with a pull tab or a stay-on tab and a press button as an opening sealer, where the tab pivotally connects to the upper surface of the container e.g. can through a connecting element such as a stud or screw defining the tab's rotation axis. The safety mechanism comprises at least one stopper configured to prevent rotation of the pull or stay-on tab around its axis, for preventing unauthorized access to the inner cavity of the container  
30 while the sealer thereof is maintained by rotating the tab and exposing a portion of the surface that would be hidden by the tab if not rotated for penetrating into the container by punctuating the exposed portion and then hiding the penetration hole by rotating the tab back to its original position opposite the sealer.

[0055] Reference is now made to **Figures 6A-6C** showing a safety mechanism for a stay-on tab closure of a can container **60**, according to some embodiments. The stay-on tab closure includes a stay-on tab **63** and press button sealer **62** for sealing an opening at the upper part **61** of the can **60**. The closure mechanism is stay-on tab **63** connects to the upper part **61** of the can **60** via a connecting stud or screw connector **65**. The safety mechanism includes two stoppers **610a** and **610b**, which protrude from the upper part **61** cover of the can **60** configured as integral part of the can upper part **61** or attached thereto.

[0056] These two stoppers **610a** and **610b** are positioned adjacent to sides of the stay-on tab **63** to prevent rotation of the tab **63** thereby preventing unauthorized accessing the inner cavity of the can **60** by attempting to punctuate a surface of the upper part **61** that is adjacent to the connector **65**.

[0057] **Fig. 7** shows a safety mechanism for preventing rotation of a pull tab **72** for pulling an upper face **71** of a can **70**, pivotally connecting to the upper surface **71** via a stud connecting element **73**. The safety mechanism includes a pin **710** located over the pull tab **72** protruding inwardly penetrating the upper surface **71** of the can **70** for connecting the pull tab **72** to the upper surface **71**, according to an alternative embodiment of the invention. The connecting pin **710** is located offset from the rotation axis of the tab **72** defined by the connecting stud **73**.

[0058] **Fig. 8** shows a safety mechanism for preventing rotation of a pull tab **82** for pulling an upper face **81** of a can **80** connected to the cover **81** via a connector **83**, wherein the safety mechanism includes a fastener **810** fastening the pull tab **82** to the cover **81** of the can **80** to prevent rotation of the pull tab **82**, according to another embodiment of the invention.

[0059] **Fig. 9** shows a safety mechanism for preventing rotation of a pull tab **92** for pulling an upper face **91** of a can **90** connected to the cover **91** via a connector **93**, wherein the safety mechanism includes two protrusions **910a** and **910b** located adjacent to the pull tab **92** adjacent to opposite sides thereof for preventing rotation of the pull tab **92**, according to yet another embodiment of the invention. The protrusions **910a** and **910b** may be integrally connected to the can upper face **91** or separately connected thereto. As shown in **Fig. 8**, the pull tab **82** is designed such that it has two recesses for fitting the stopper protrusions **810a** and **810b** therein.

[0060] The slidable member of the safety mechanisms of the present invention may also be used for covering and optionally also sealing the opening formed after the can top sealer (e.g. the push button or flexible sealer foil) is opened for allowing the user of the container to re-seal it for continuous use.

5 [0061] Reference is now made to **Figures 10A-10D**, which show a can top **1000** with a safety mechanism for a container such as a beverage can or parts of the mechanism. The can top **1000** has a can top member **1200** and a slidable member **1100**, wherein the slidable member **1100** thereof also allows re-sealing the can opening after its press button sealer **1210** has been opened, wherein the post-opening sealing is done  
10 by adding a sealing strip **1150** such as a silicon strip to the periphery bottom edge **1130** of the slidable member **1120**, according to some embodiments of the invention.

[0062] According to some embodiments of the invention, as shown in **Figures 10A-10C**, the can top member **1200** of the can has a protruding rim **1240** and an upper face **1230** integrally connected thereto, wherein the upper face **1230** is punched such as  
15 to form thereover tracks **1220a** and **1220b** and has an openable sealer **1210** with a sloped configuration protruding from the surface of the upper face **1230** and connected thereto through a weak connection allowing easy opening thereof.

[0063] The slidable member **1100** has a sloped protrusion **1120** that corresponds in shape and size to the sealer **1210** protruding from a base **1110** thereof, such that when  
20 slid backwards for opening of the sealer **1210** it will push the sealer **1210** inwardly into the can interior for opening thereof. The sliding of the slidable member **1100** for this initial opening of the can will cause the sealer **1210** to partially tear from its connection to the can upper face **1230** forming an opening thereover.

[0064] This opening formed by the unsealing of the sealer **1210** can be recovered  
25 and re-sealed by the slidable member **1100** simply by sliding thereof back to its initial position over the opening formed.

[0065] The slidable member **1100** bottom side periphery **1130** or part thereof is coated or added with a sealing material strip **1150** such as silicon or rubber or a coating layer strip that will increase sealing properties of the slidable member **1100** by  
30 increasing the contact area between this periphery area **1130** and the inner side of the tracks **1220a** and **1220b**.

[0066] The can top member **1000** and safety mechanism thereof may be entirely made from the same can material except for the sealing strip **1150** such as aluminum or

aluminum alloy and the like, where all its protrusions and niches and curvatures are produced through punching.

5 [0067] The slidable member **1100** may also include one or more gripping protrusions such as protruding stripes **1113a-1113c** (which may be produced via punching thereof) and/or a protrusion **1112** for easy pushing or pulling of the slidable member **1100** backwards for opening and unsealing of the can for accessing its content. The front edge **1111** of the slidable member **1100** may extend from this frontal protrusion **1112**.

10 [0068] The slidable member **1100** can be used as a cover and sealer of the opening by simply sliding thereof over the formed opening of the can top **1000** where the sealing strip **1150** thereof will contact (engage) the tracks **1220a** and **1220b** and the upper surface **1230** other parts for sealing the opening from all periphery sides of the slidable member **1100**.

15 [0069] The slidable member **1100** can be produced separately from the can top member **1200** and then combined by, for example, bending the slidable member **1100** inwardly or outwardly for insertion thereof into the tracks **1220a** and **1220b**. After the entire can top **1000** is assembled, the can top **1000** can be connected (e.g. pressed) to the can container body after it has been filled with its content such as beverage, foodstuff and the like, as typically done in can manufacturing.

20 [0070] **Figures 11A-11F** show a can top **2000** with a safety mechanism for a container such as a beverage can having a can top member **2200** and slidable member **2100**, which also allows sealing the can opening after its press button sealer **2210** has been opened, wherein the post-opening sealing is enabled by the configuration of the slidable member **2100** periphery **2115** having a curved shape fit to engage the tracks  
25 **2220a** and **2220b** of the can top member **2200** upper surface **2230**.

[0071] As mentioned above, the can top member **2200** has a protruding rim **2240** connecting to the can top upper surface **2230**, in which tracks **2220a** and **2220b** are located, e.g. formed via punching their shape through the upper surface **2230** of the can top member **2200**.

30 [0072] The can top member **2200** also includes a sloped press button sealer **2210** similar in function and configuration to the sealer **1210** and fitted in shape and size to the sloped protrusion **2120** of the slidable member **2100**. The slidable member **2100**

has protruding stripes **2113a-2113c** and frontal protrusion **2112** and frontal edge portion **2111** similar to those of slidable member **1100**.

[0073] As shown in **Fig. 10D**, when the slidable member **1110** is slid backwards it will cause the sealer **1210** to open downwardly inwardly into the can thereby forming an opening **2** over the can top member **1200** for accessing material inside the can container **998** due to the complimentary sloped shapes of the sealer **1210** and slidable member **1110**. To reseal the opening **2** that is formed by the unsealing of the sealer **1210**, the slidable member **1110** should simply be slid forward back to its initial position over the opening **2**, while its sealing properties (e.g. the sealing material strip in this case) will prevent the material inside the can **988** from exiting, spilling, pouring etc.

[0074] As illustrated in **Figures 11E** and **11F** and also in **Figures 11H** and **11I**, the curved periphery **2115** of the slidable member **2100** base **2110** is fit to be inserted to the tracks **2220a** and **2220b** at sides thereof and to the front and rear sides of the can top surface **2230** such as to have at least a periphery line or a surface of the slidable member **2100** in contact with the surface **2230** of the can top for sealing thereof when positioned over the opening formed by unsealing of the sealer member **2210**.

[0075] As indicated in **Fig. 11I**, the angles “ $\alpha$ ” (ALPHA) and “ $\beta$ ” defining shape and curvature of the tracks **2220a** or **2220b** and the angle “ $\theta$ ” (THETA) may be such that the outer wall **2116** of the slidable member **2100** periphery **2115** contact in full the inner walls of the tracks **2220a/2220b** for sealing thereof. In this particular example of **Fig. 11I**  $\alpha = 90$  degrees.

[0076] As mentioned above in regards to the embodiments illustrated in **Figures 10A-10C**, the can top member **2200** can be separately manufactured from the slidable member **2100** and then the slidable member **2100** can be inserted through the can top tracks **2220a** and **2220b** for assembling thereof. Once the slidable member and can top are assembled they can be attached to the can body **999** containing the beverage or any other material therein.

[0077] According to some embodiments of the invention the outer wall **2116** can also be coated with a sealing material or connected to a sealing material strip such as a silicon strip to further enhance the sealing properties thereof.

**[0078]** The safety mechanism of the present invention can be used and integrated to any container type top and not just specifically to a can container. For example, a box, a package and the like containing therein any type of material in any state liquid, gas or solid (powder etc.). Embodiments of the safety and sealing mechanism described above  
5 may be integrated onto the container top or added on thereto by adding on the tracks and slidable member.

**[0079]** Many alterations and modifications may be made by those having ordinary skill in the art without departing from the spirit and scope of the invention. Therefore, it must be understood that the illustrated embodiment has been set forth only for the  
10 purposes of example and that it should not be taken as limiting the invention as defined by the following invention and its various embodiments. For example, notwithstanding the fact that the elements are set forth in a certain combination, it must be expressly understood that the invention includes other combinations of fewer, more or different elements, which are disclosed in above even when not initially stated in such  
15 combinations. A teaching that two elements are combined may be further to be understood as also allowing for a combination in which the two elements are not combined with each other, but may be used alone or combined in other combinations. The excision of any disclosed element of the invention is explicitly contemplated as within the scope of the invention.

**[0080]** The words used in this specification to describe the invention and its various embodiments are to be understood not only in the sense of their commonly defined meanings, but to include by special definition in this specification structure, material or acts beyond the scope of the commonly defined meanings. Thus if an element can be understood in the context of this specification as including more than one meaning,  
25 then its use must be understood as being generic to all possible meanings supported by the specification and by the word itself.

**[0081]** The definitions of the words or elements are, therefore, defined in this specification to include not only the combination of elements which are literally set forth, but all equivalent structure, material or acts for performing substantially the same  
30 function in substantially the same way to obtain substantially the same result. In this sense it is therefore contemplated that an equivalent substitution of two or more elements may be made for any one of the elements or that a single element may be substituted for two or more elements. Although elements may be described above as

acting in certain combinations and even initially stated as such, it is to be expressly understood that one or more elements from a stated combination can in some cases be excised from the combination and that the stated combination may be directed to a sub-combination or variation of a sub-combination.

5 [0082] Insubstantial changes from the subject matter as viewed by a person with ordinary skill in the art, now known or later devised, are expressly contemplated as being equivalently within the scope of the present invention. Therefore, obvious substitutions now or later known to one with ordinary skill in the art are defined to be within the scope of the defined elements.

10 [0083] The present invention is thus to be understood to include what is specifically illustrated and described above, what is conceptually equivalent, what can be obviously substituted and also what essentially incorporates the essential idea of the invention.

15 [0084] Although the invention has been described in detail, nevertheless changes and modifications, which do not depart from the teachings of the present invention, will be evident to those skilled in the art. Such changes and modifications are deemed to come within the purview of the present invention.

**CLAIMS**

1. A safety cover mechanism for a container having an upper surface with an opening, said safety cover mechanism comprising:
  - a. a sealer that seals the opening of the container, wherein the sealer is  
5 connected to a rim of the opening at the level of the upper surface and has a protrusion;
  - b. a track affixed to the upper surface of the container in proximity to the opening; and
  - c. a shutter member slidable over the track, wherein the shutter member has  
10 an elevated niche which interlocks with the protrusion of the sealer, and wherein sliding of the shutter member over the track away from the opening causes a portion of the sealer to be depressed thereby detaching the portion of the sealer from the opening.
2. The safety cover mechanism according to claim 1, wherein the track  
15 comprises two rails.
3. The safety cover mechanism according to claim 1, wherein said the track is formed by punch pressing of the upper surface of the container.
4. The safety cover mechanism according to claim 1, wherein the track protrudes from said upper surface of the container.
- 20 5. The safety cover mechanism according to claim 1, wherein said shutter member has at least one rail protrusion for easy sliding through the track.
6. The safety cover mechanism according to claim 1 further comprising at least one stopper for limiting sliding of said shutter member.
7. The safety cover mechanism of claim 6, wherein said stopper is a recess  
25 formed over the upper surface of the container.
8. The safety cover mechanism according to claim 6, wherein the at least one stopper comprises at least one front stopper loosely connected to said shutter member such that a first uncovering of the opening causes the front stopper to  
30 tear away from the shutter member thereby indicating that the first uncovering has occurred.
9. The safety cover mechanism according to claim 1, wherein the track curves at at least one edge thereof to prevent the shutter member from exceeding the track curved edge.

10. The safety cover mechanism according to claim 1, wherein the sealer covers both the opening and an edge of the container that comes in contact with a drinker's lip, for hygienically protecting the edge before use.
11. The safety cover mechanism according to claim 10, wherein the shutter member comprises a folded edge protruding down towards the upper surface of the container such that downward pressure on the shutter member tears the sealer.
12. The safety cover mechanism according to claim 10, wherein the flexible sealer is affixed to the track.
- 10 13. A container with a safety cover mechanism said container comprising:
- a. a container body having an upper surface with an opening;
  - b. a sealer that seals the opening of the container, wherein the sealer is connected to a rim of the opening at the level of the upper surface and has a protrusion;
  - 15 c. a track affixed to the upper surface of the container in proximity to the opening; and
  - d. a shutter member slidable over the track, wherein the shutter member has an elevated niche which interlocks with the protrusion of the sealer, and wherein sliding of the shutter member over the track away from the opening
  - 20 causes the protrusion of the sealer to be depressed, thereby detaching a portion of the sealer from the opening.

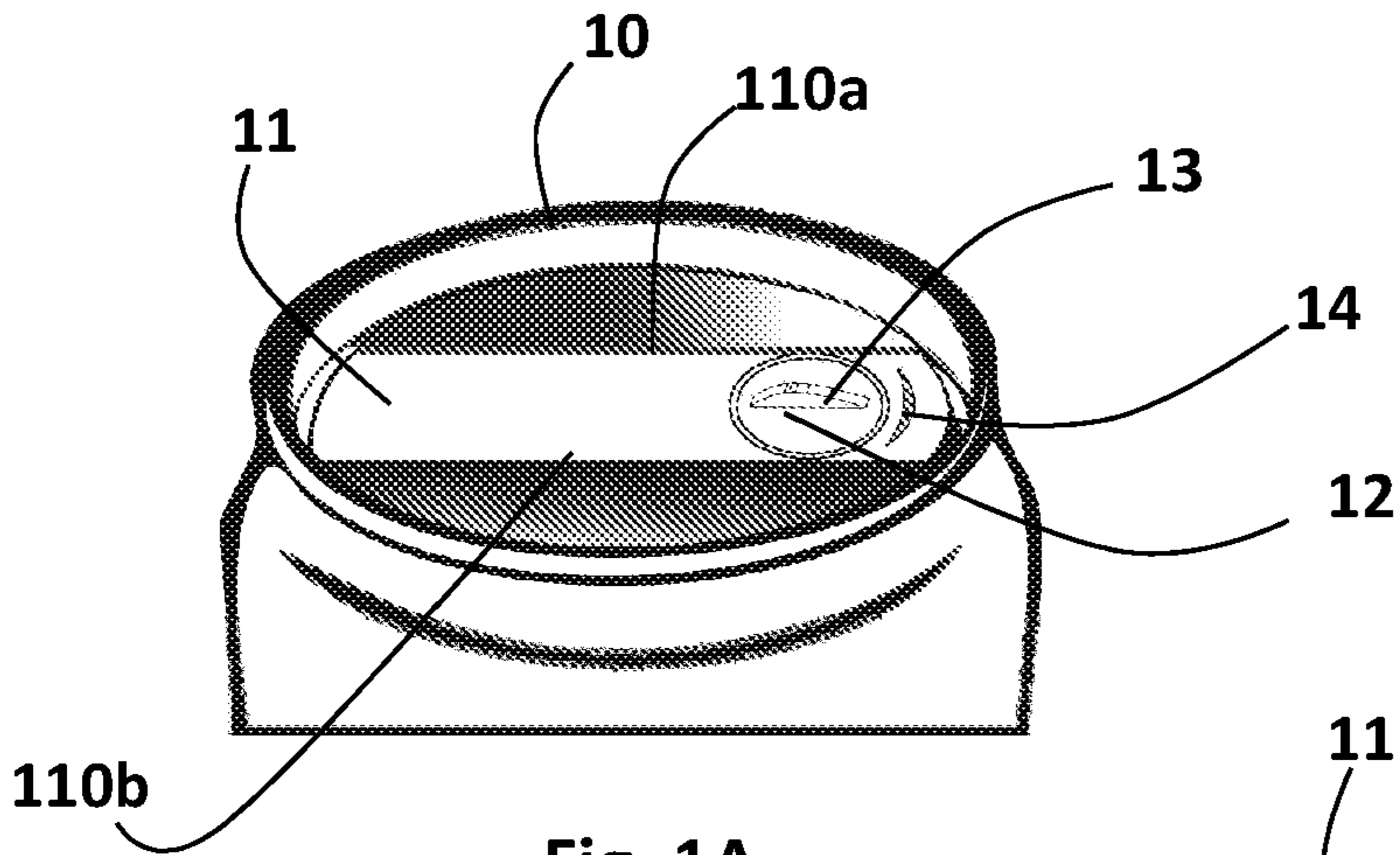

Fig. 1A

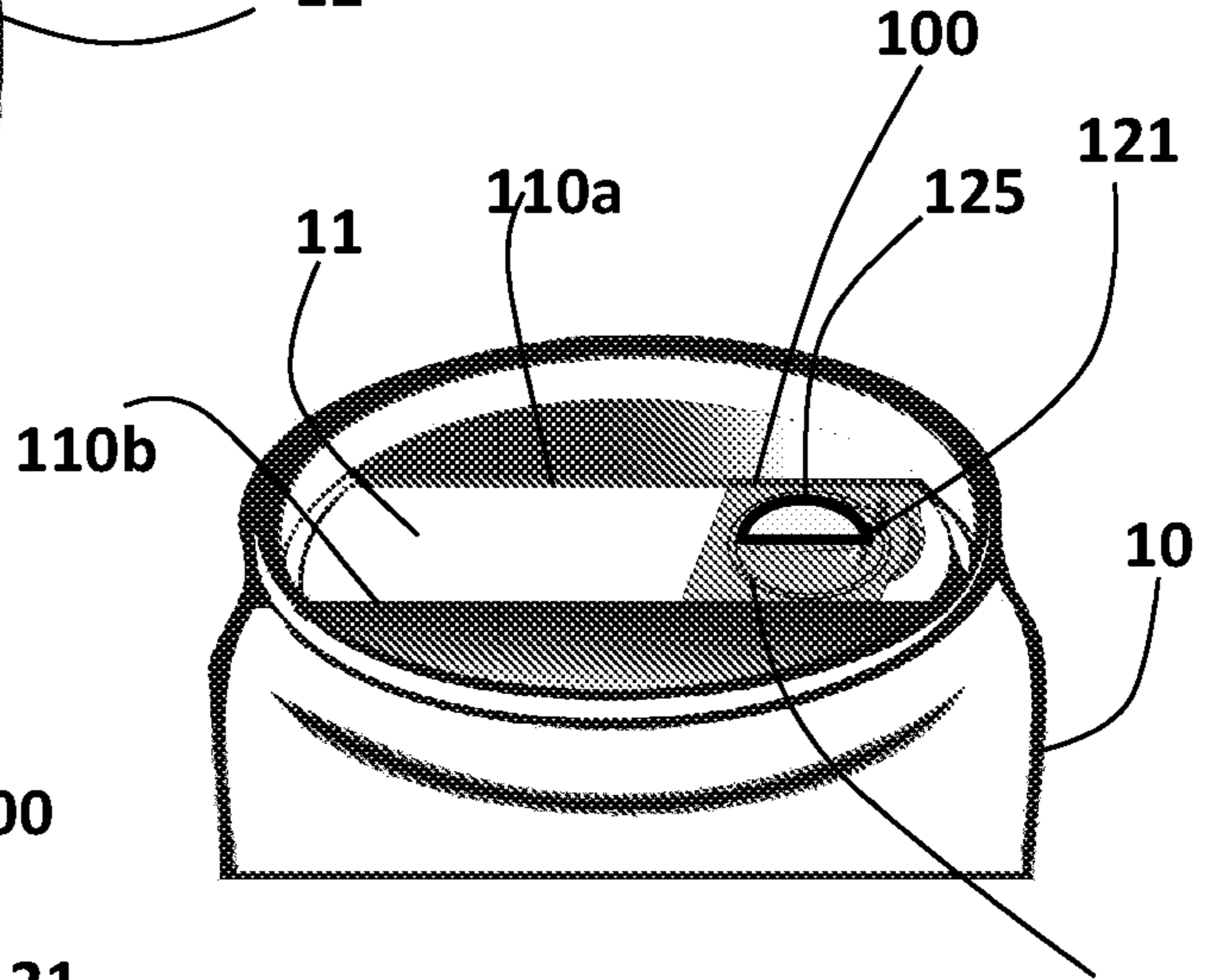

Fig. 1B

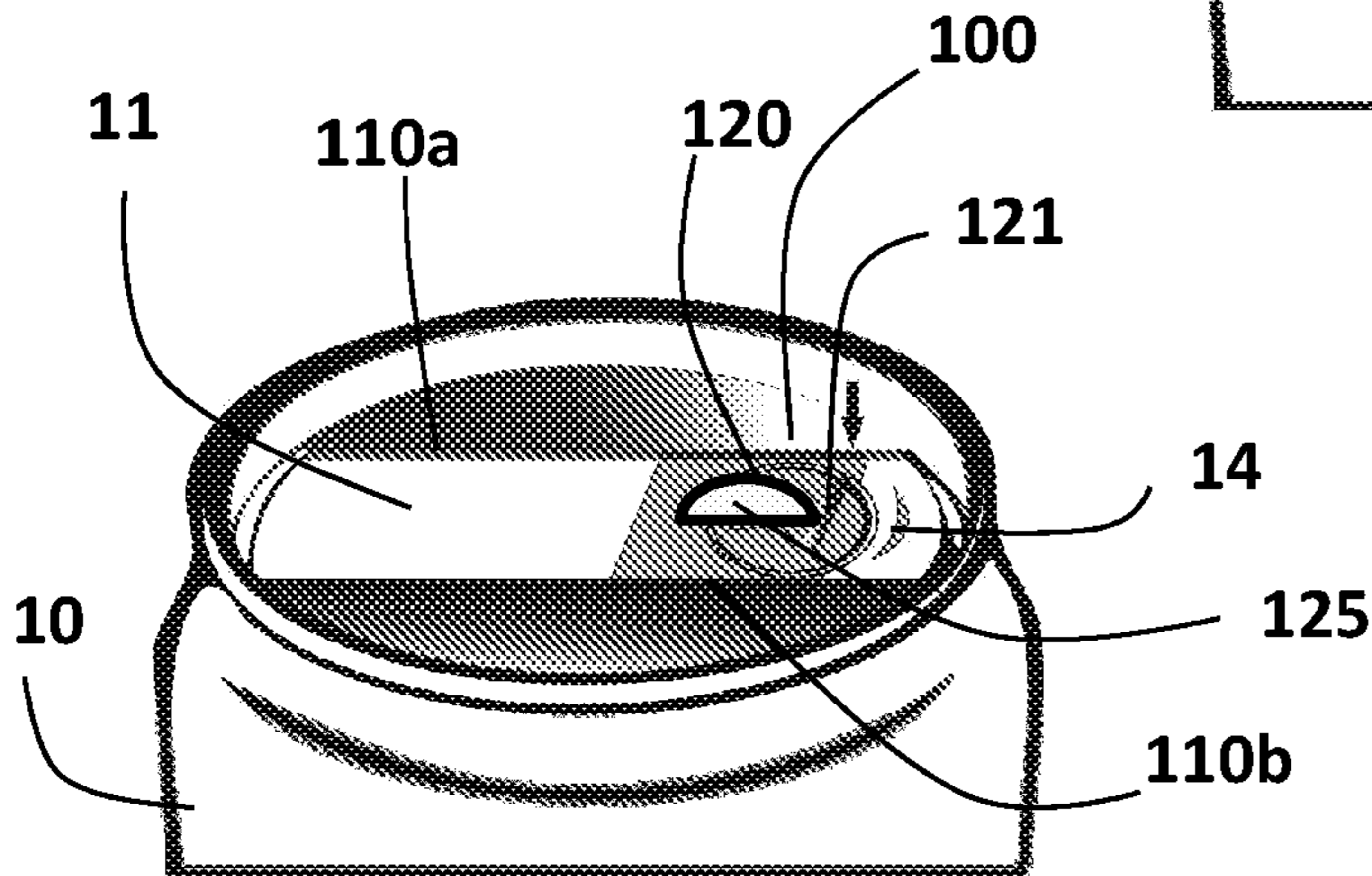

Fig. 1C

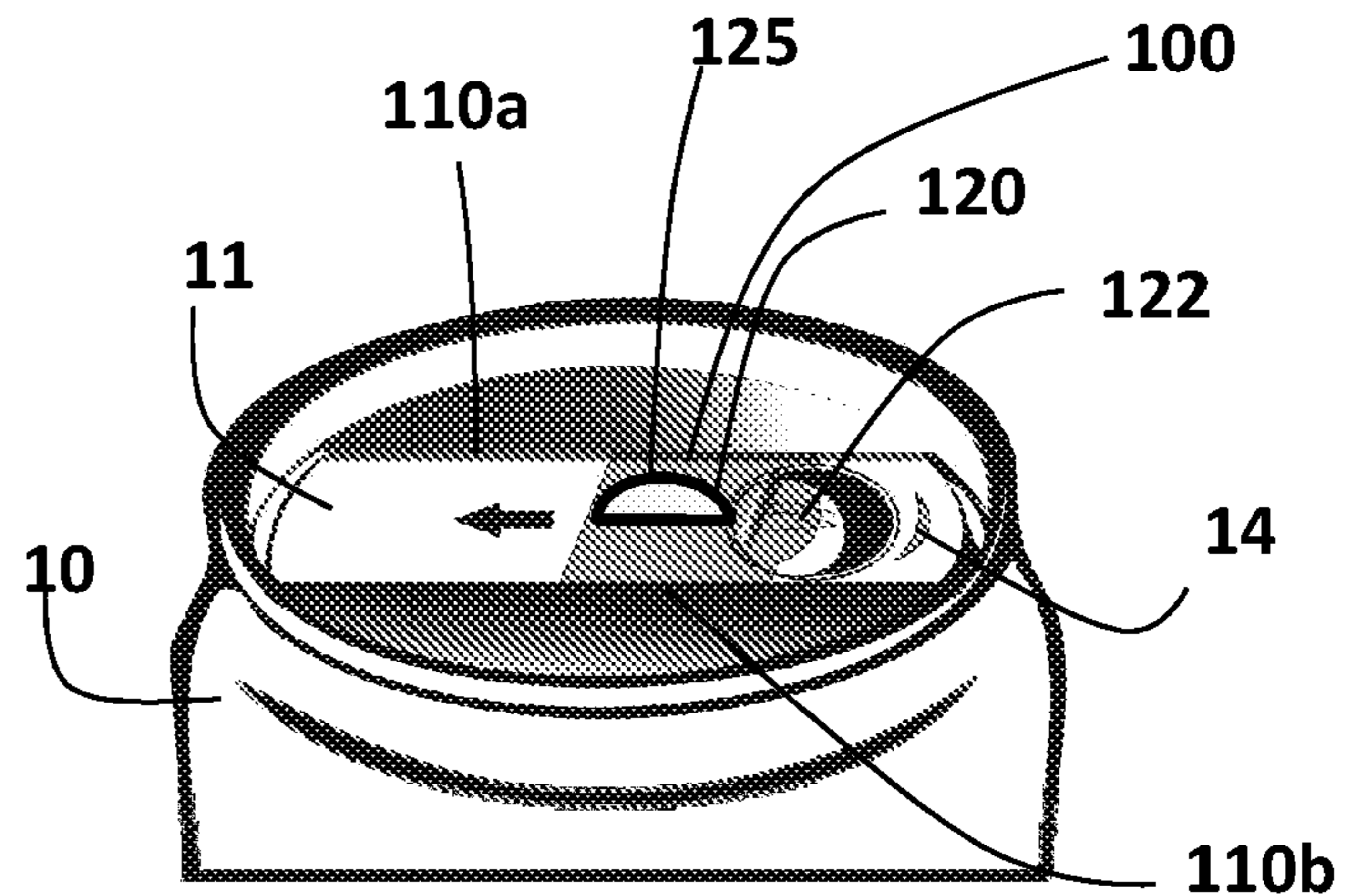

Fig. 1D

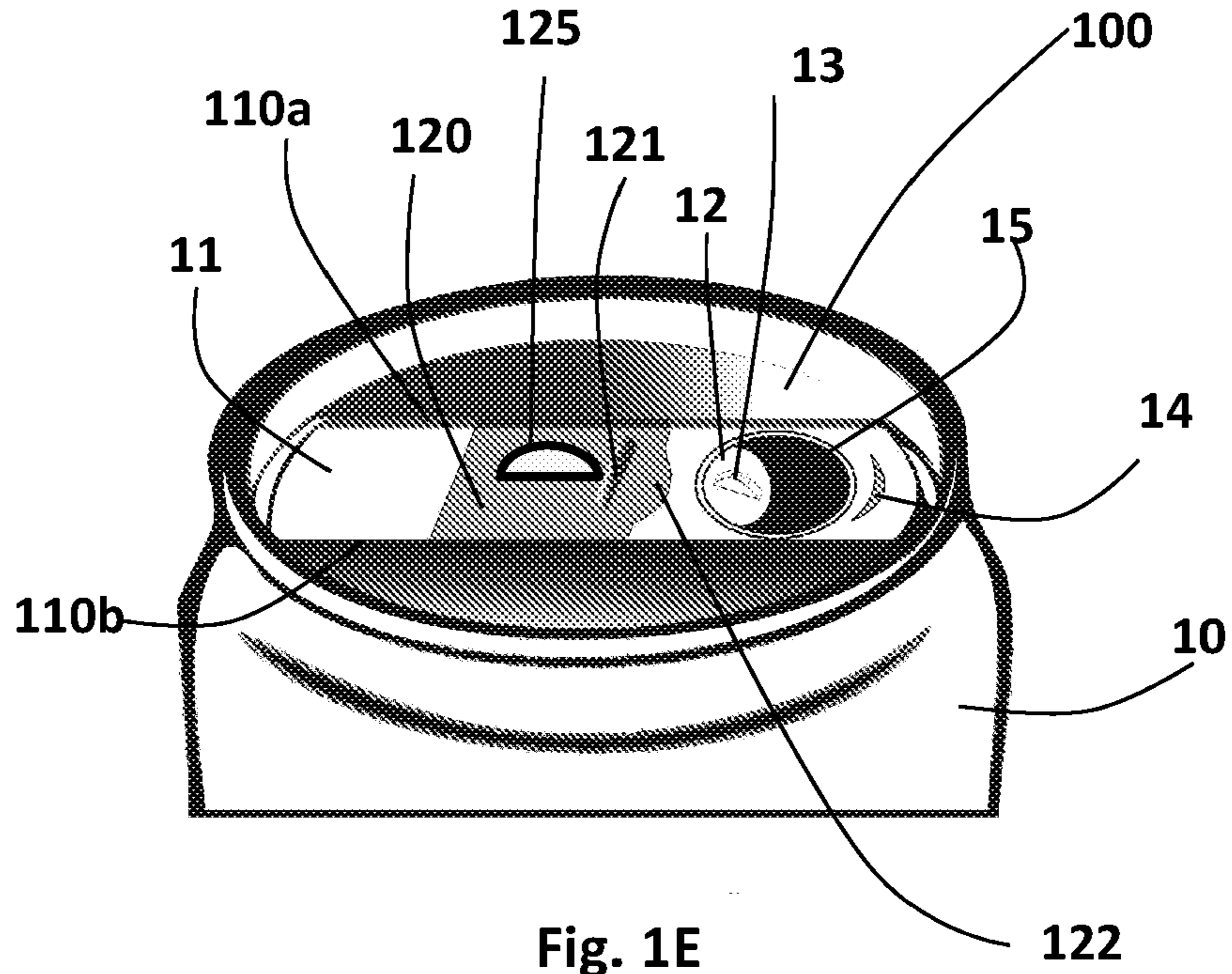

Fig. 1E

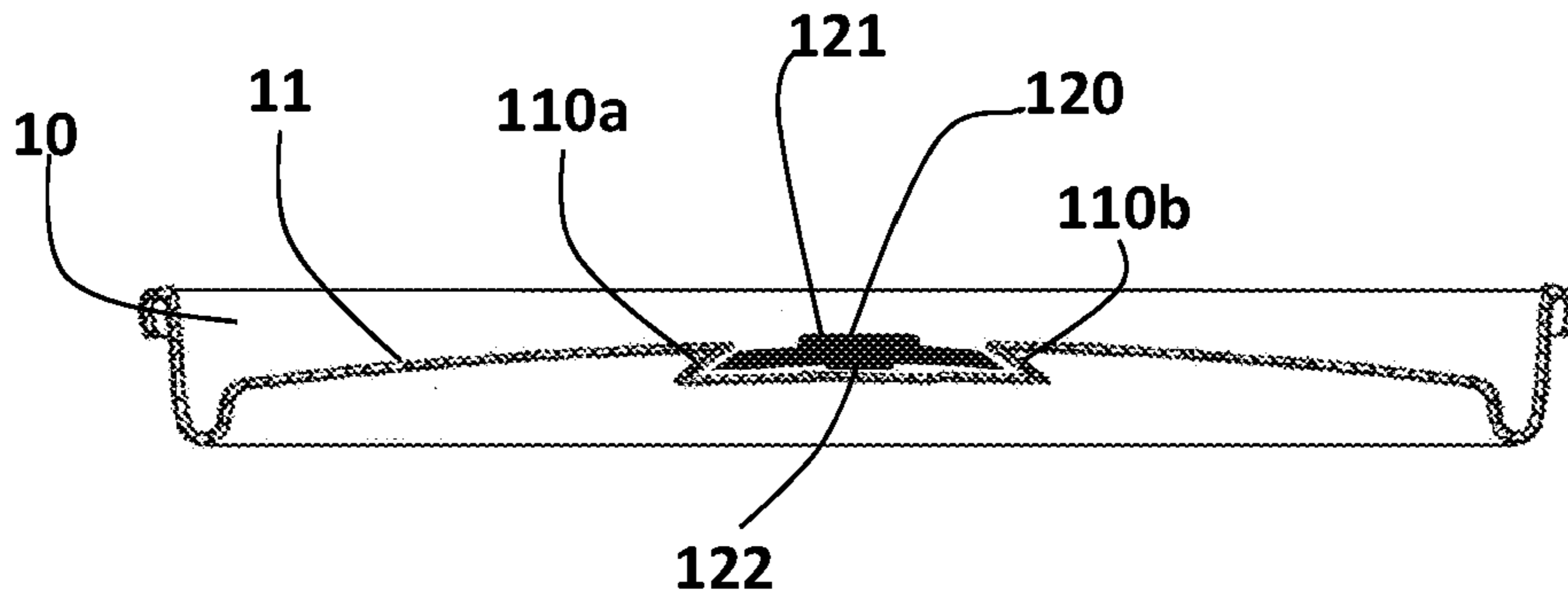

Fig. 1F

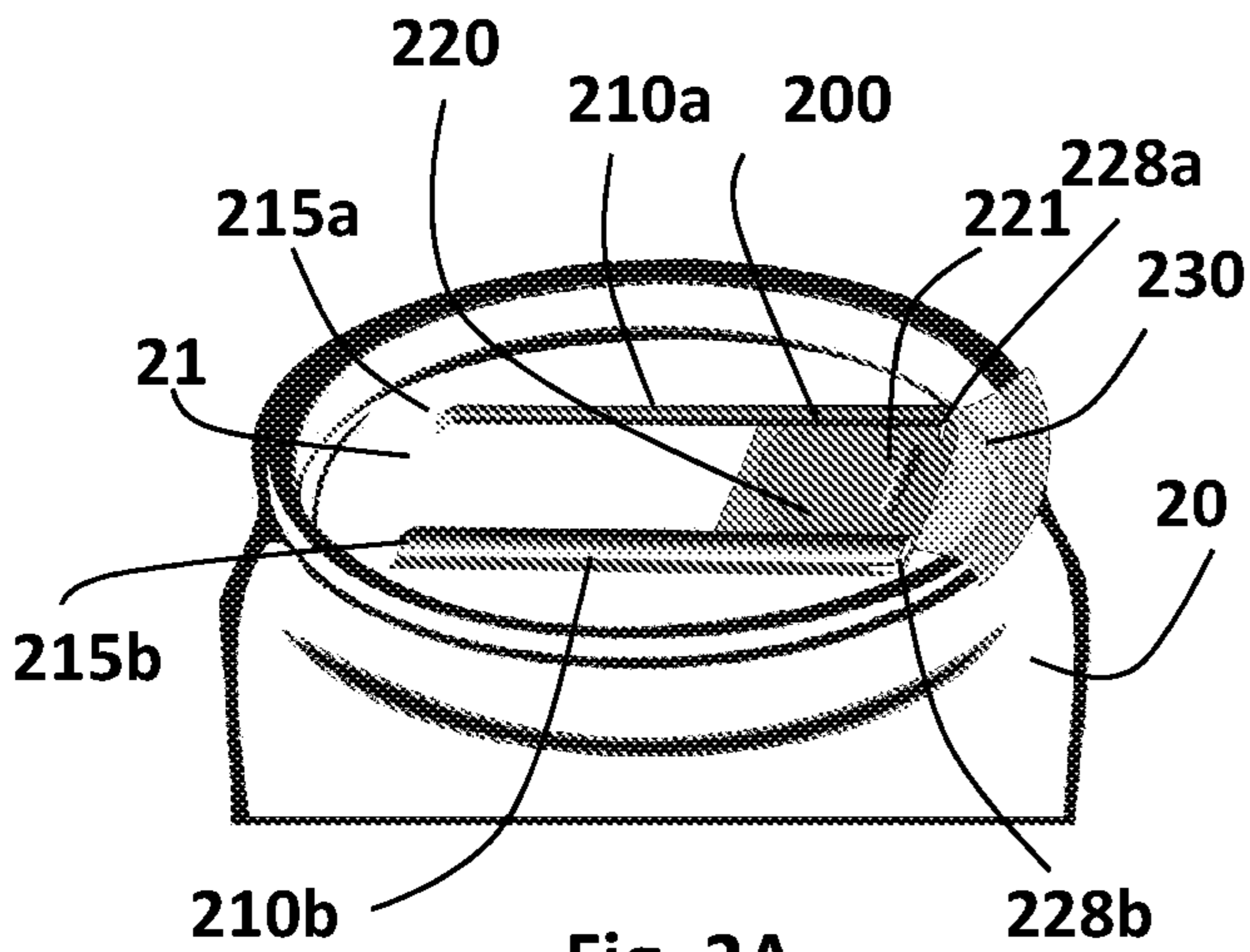

Fig. 2A

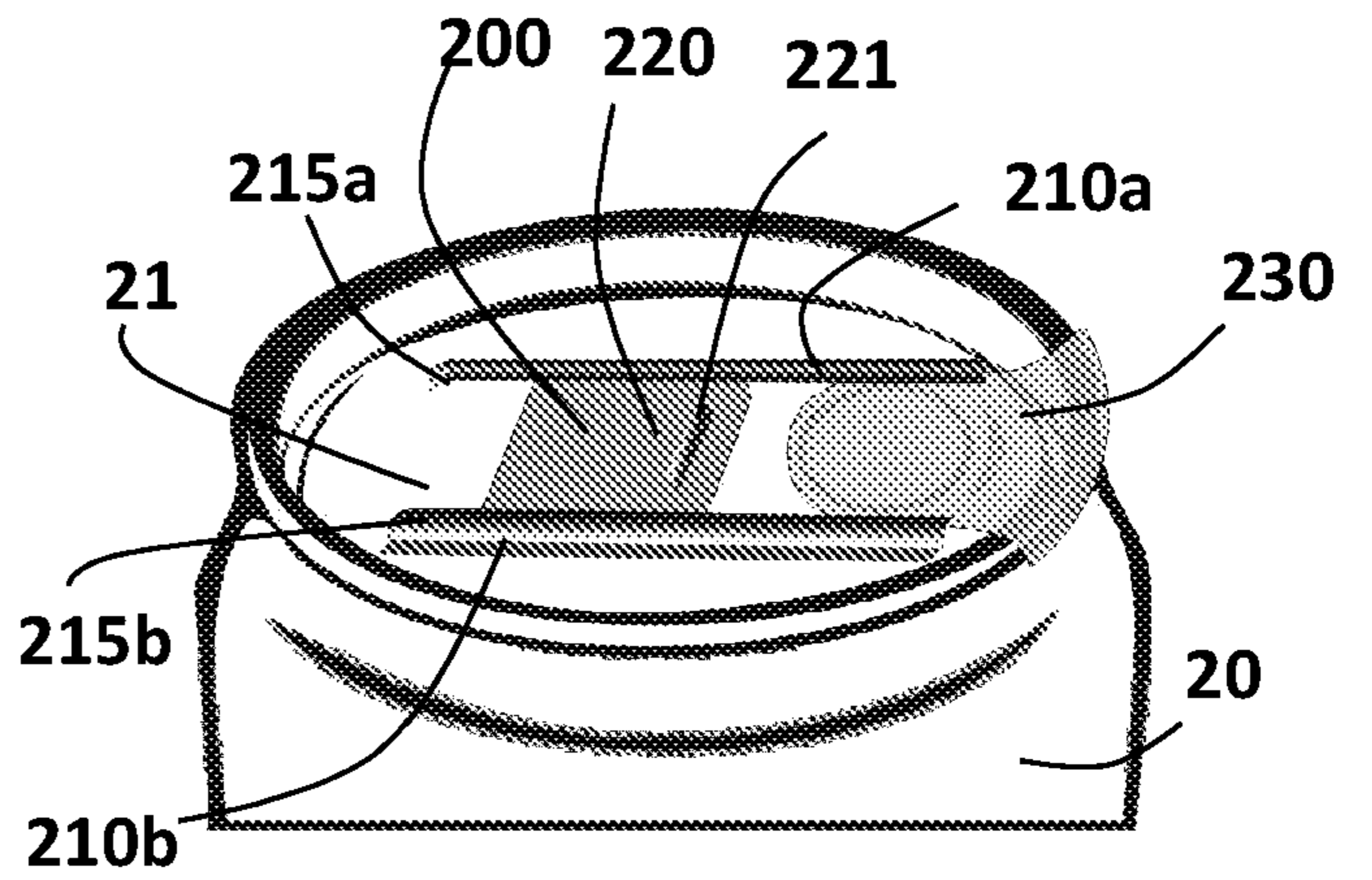

Fig. 2B

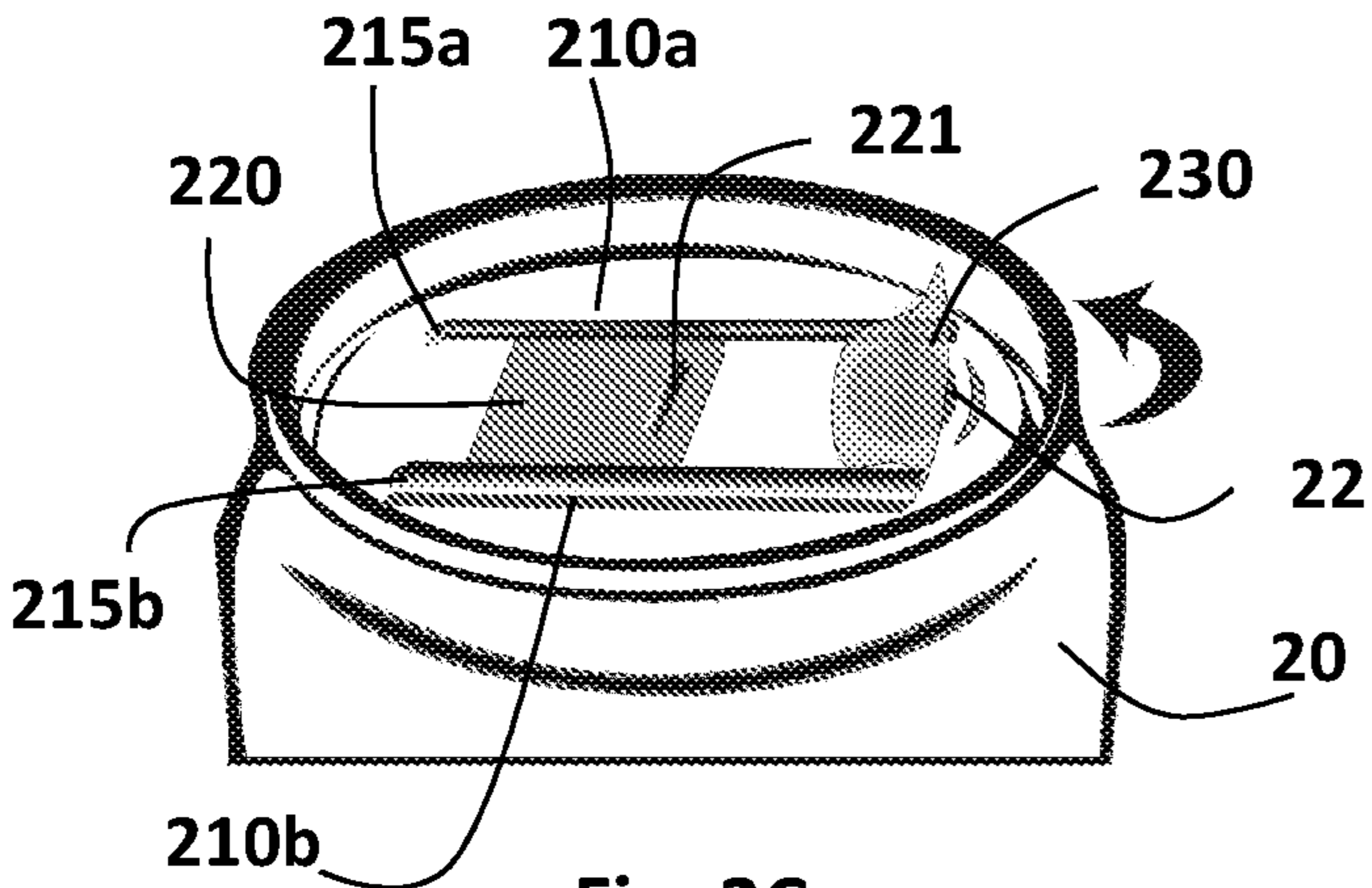

Fig. 2C

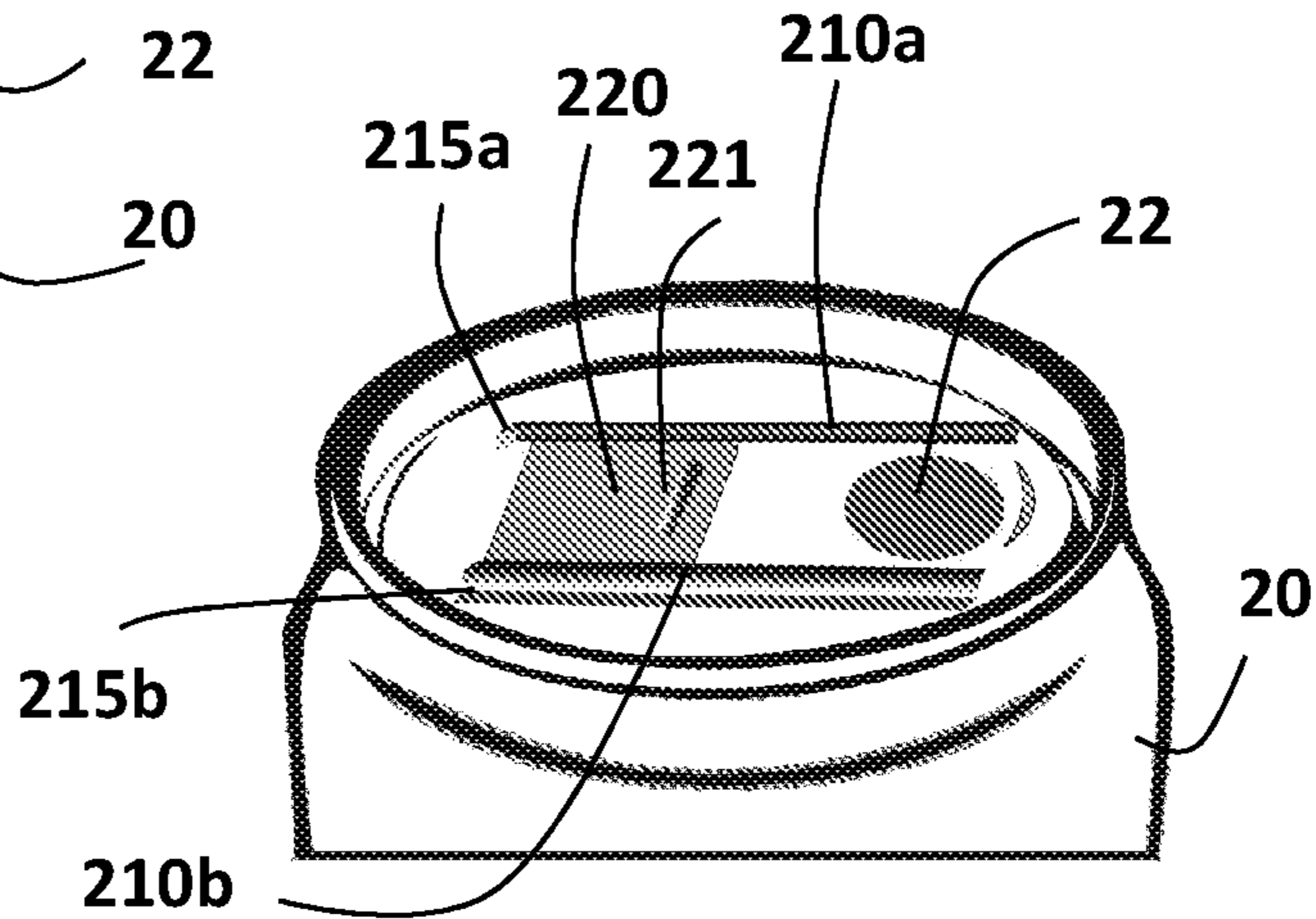

Fig. 2D

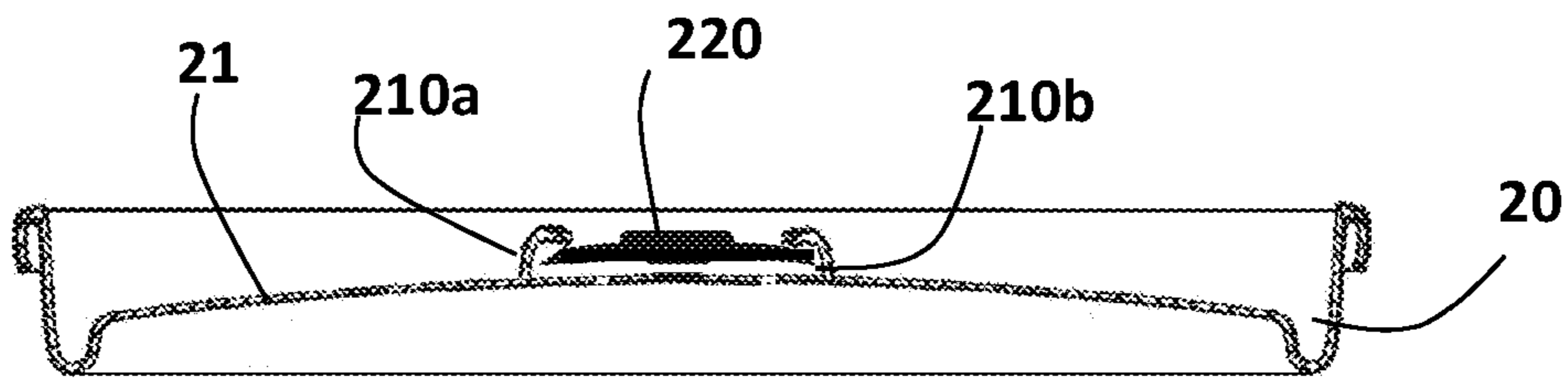

Fig. 2E

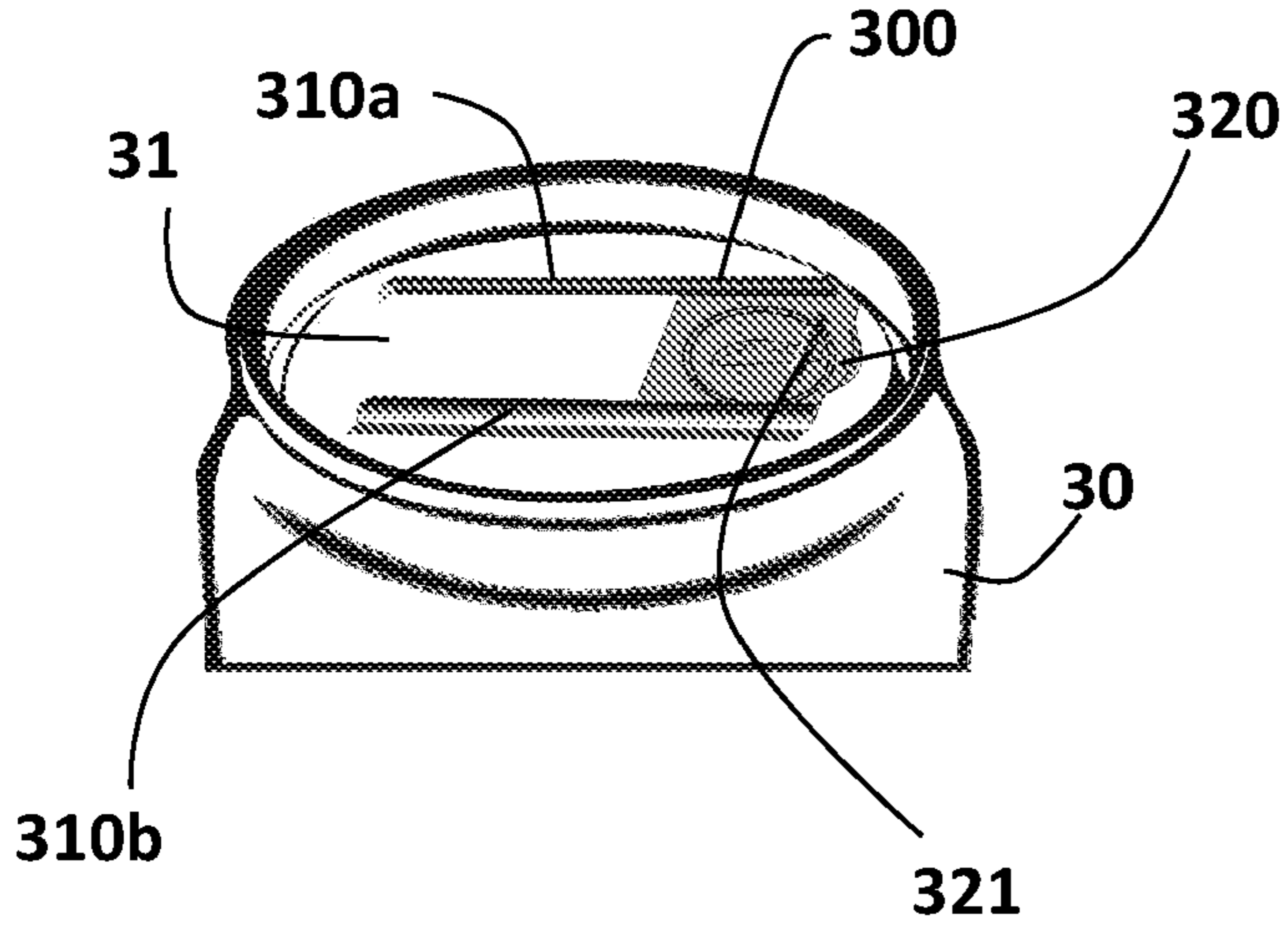

Fig. 3A

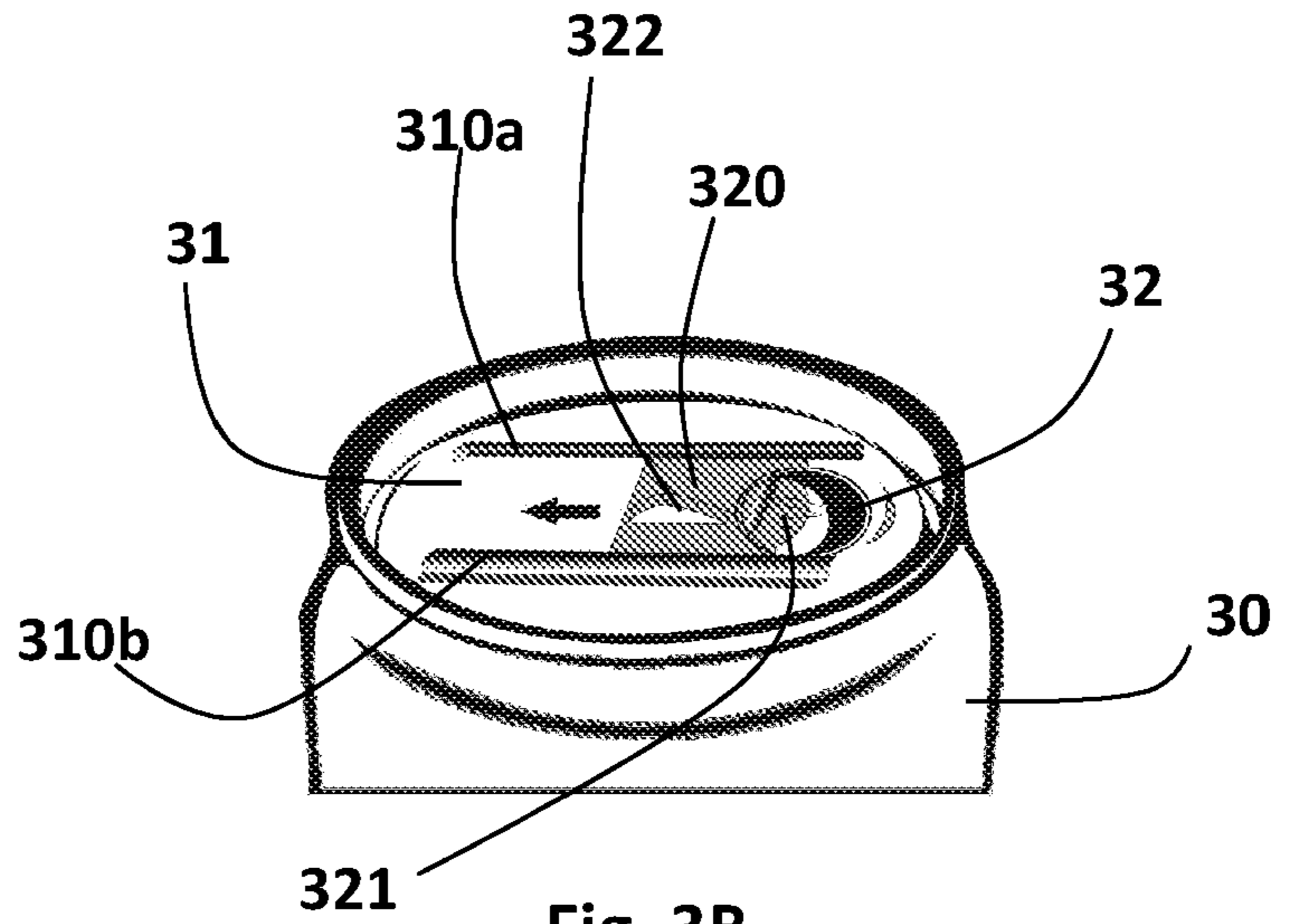

Fig. 3B

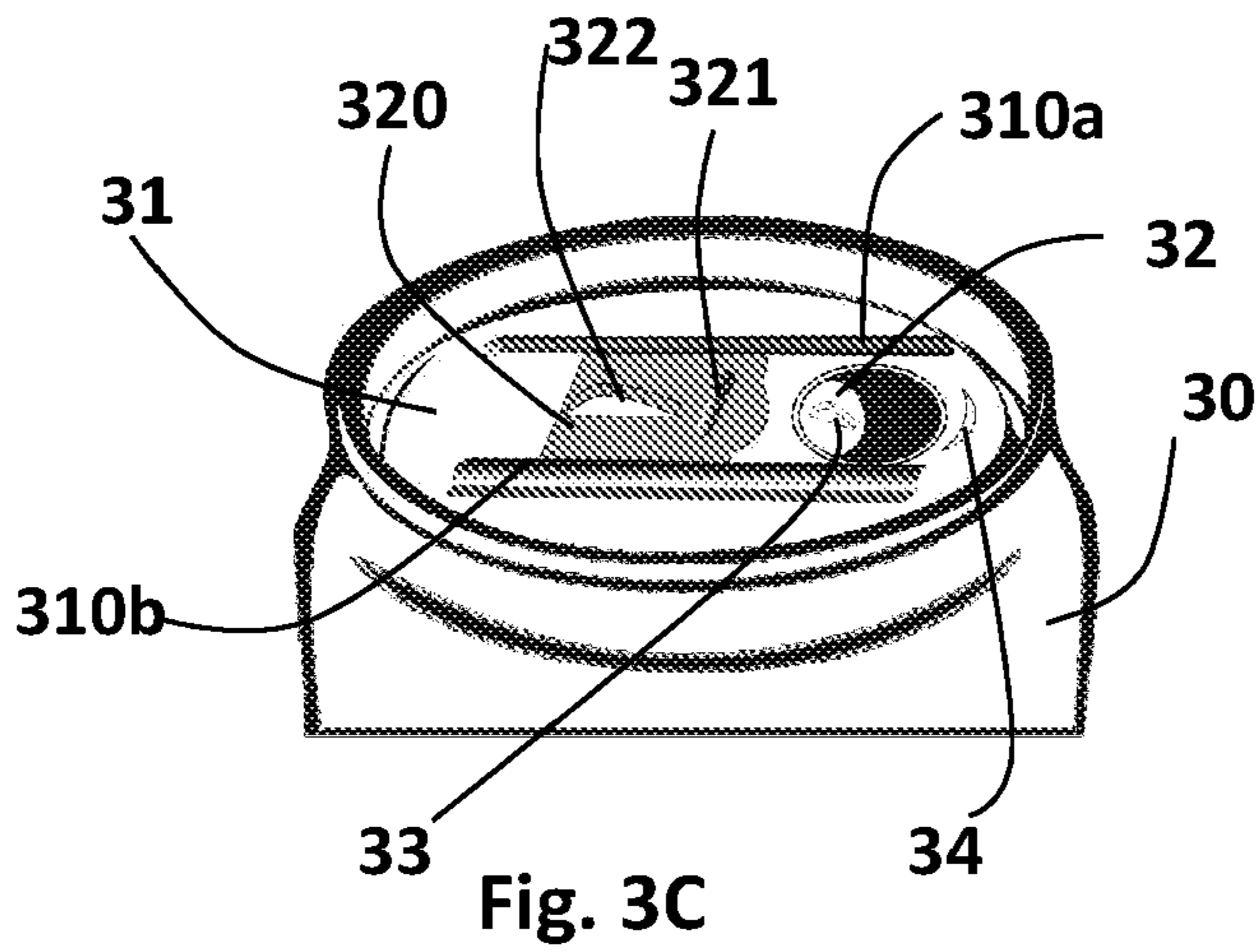

Fig. 3C

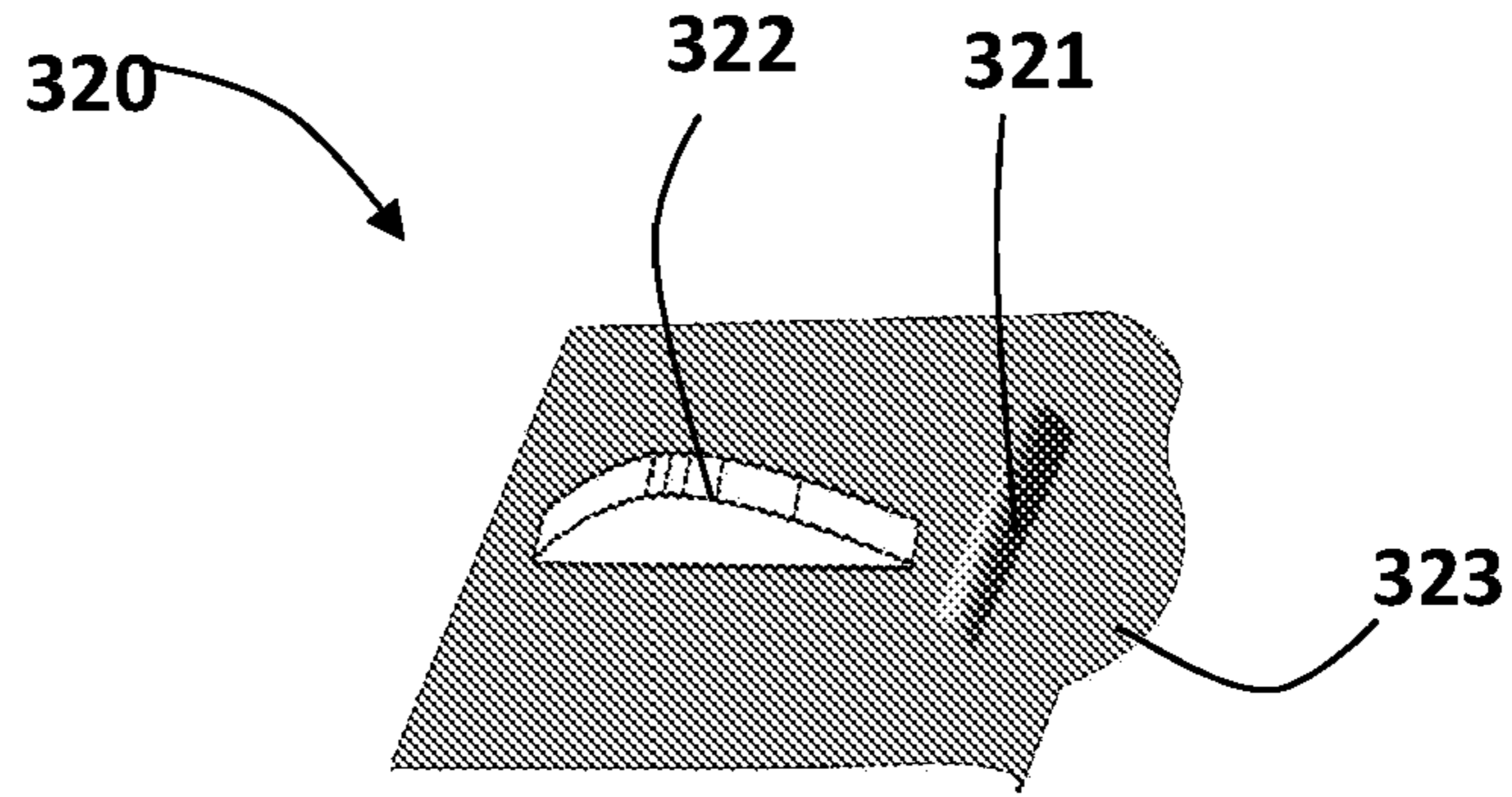

Fig. 3D

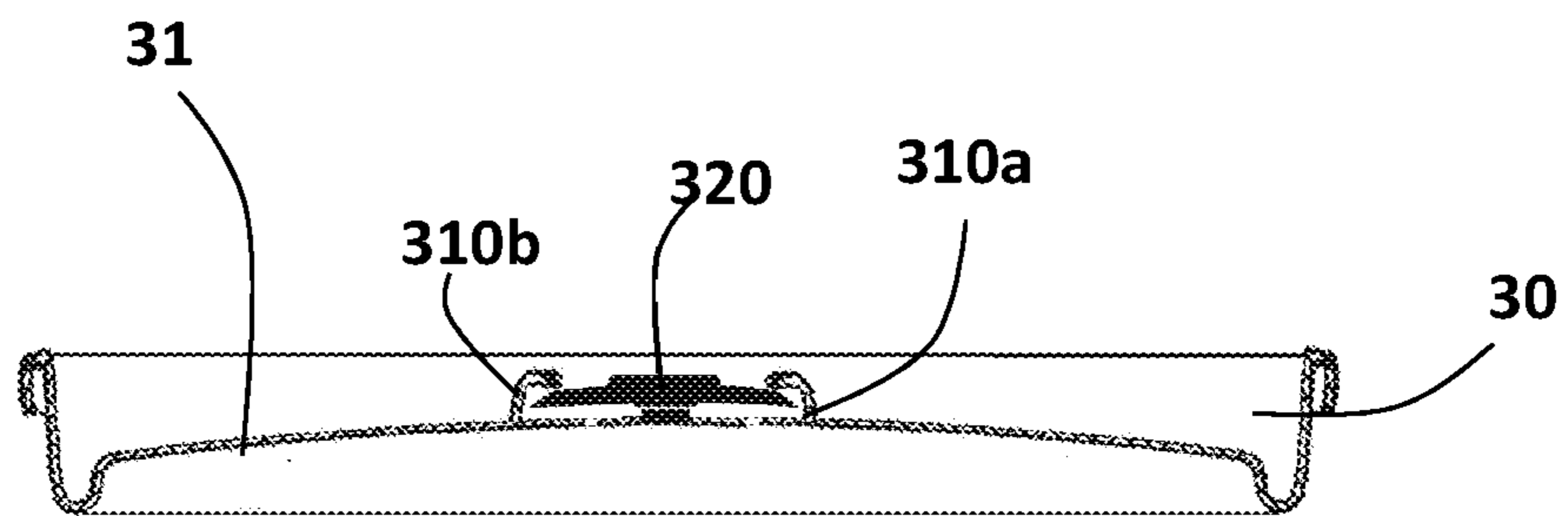
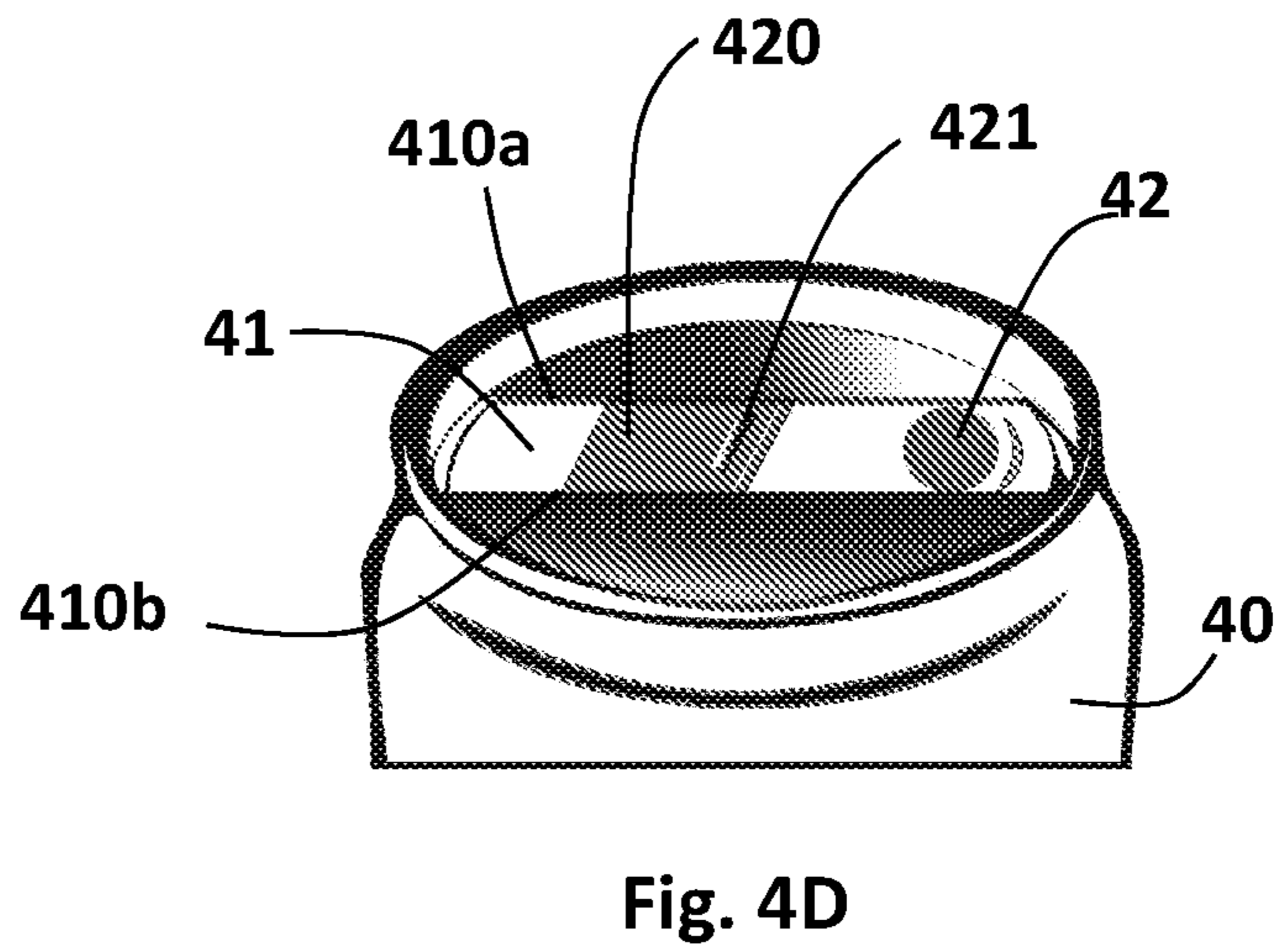
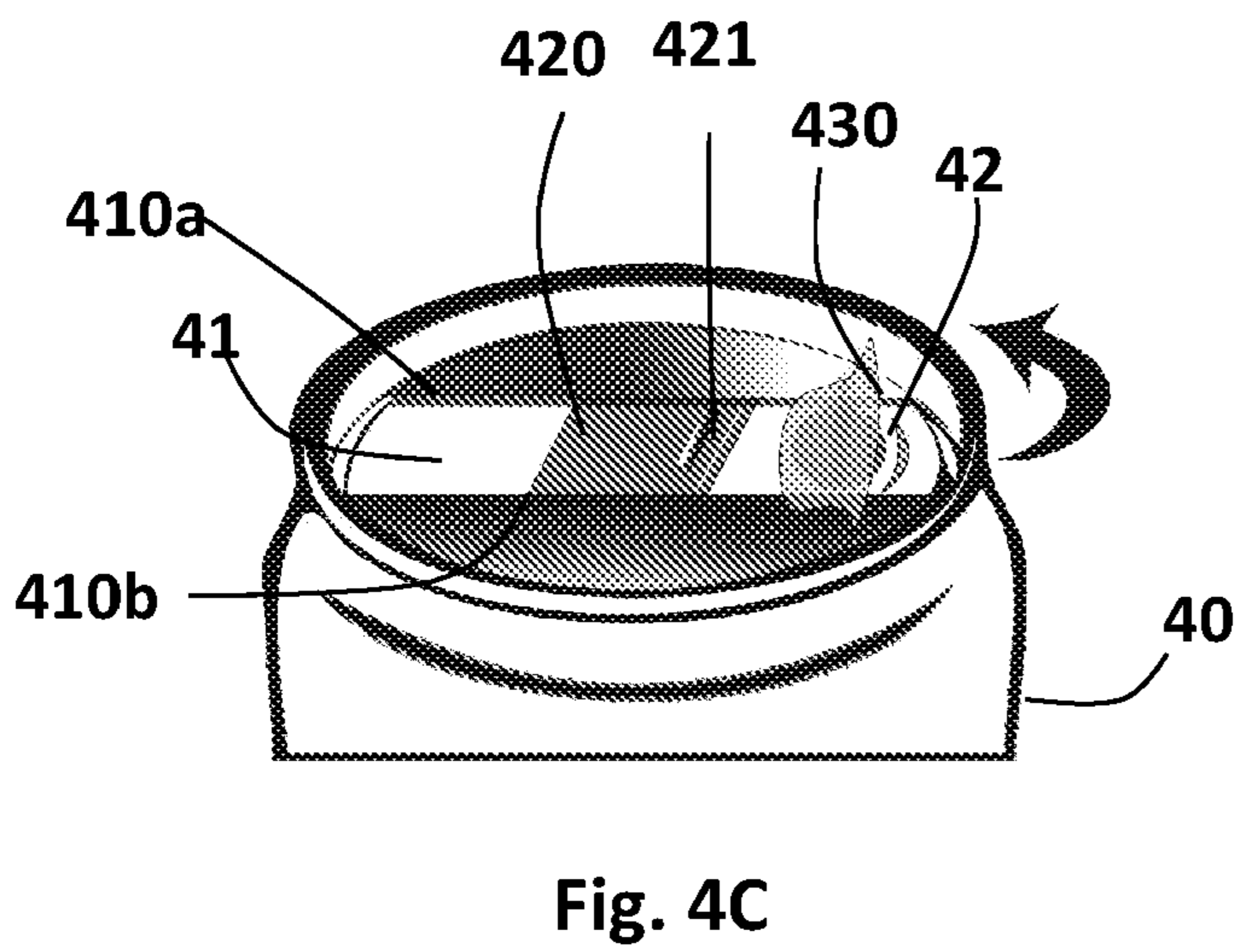
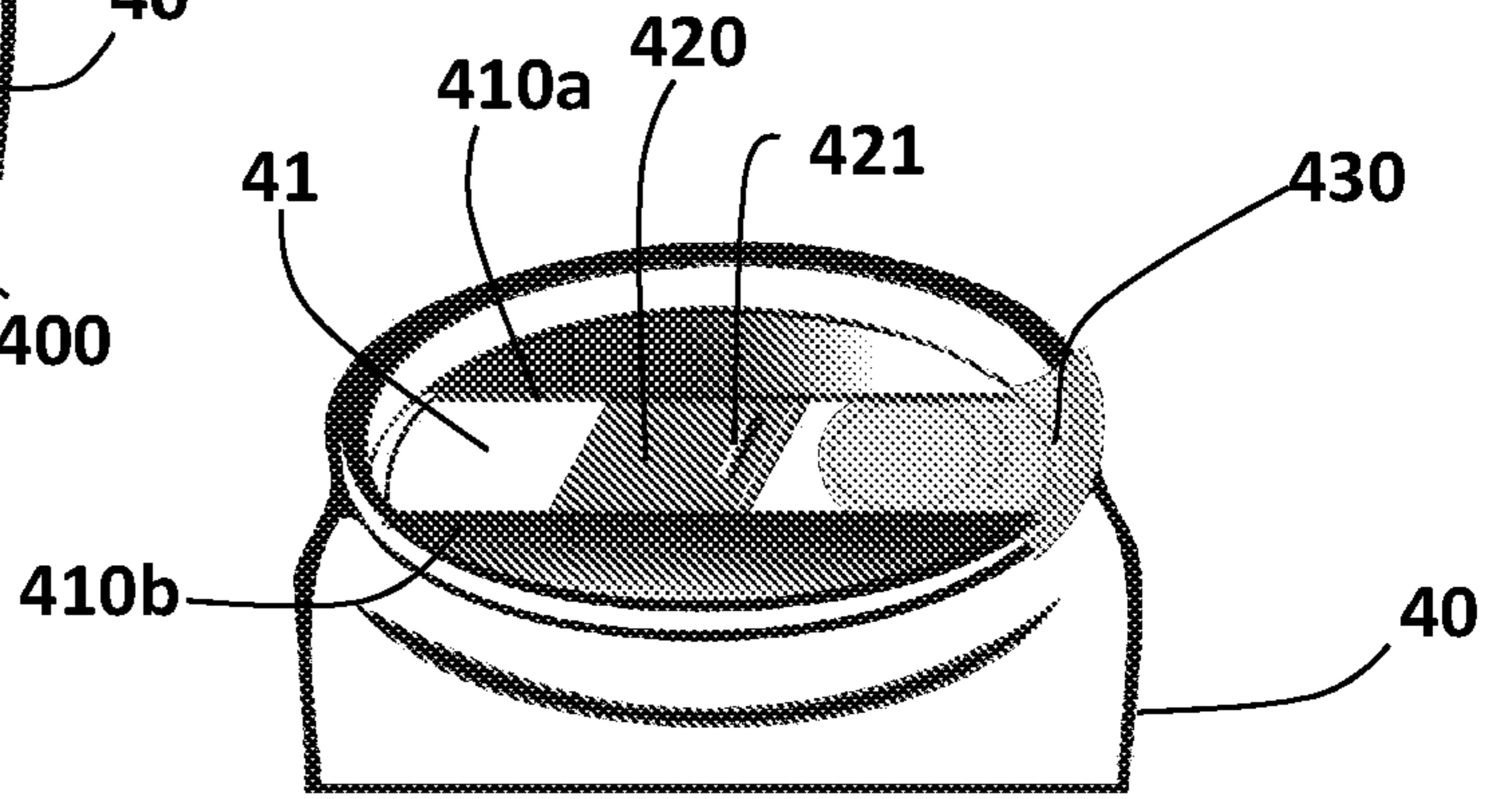
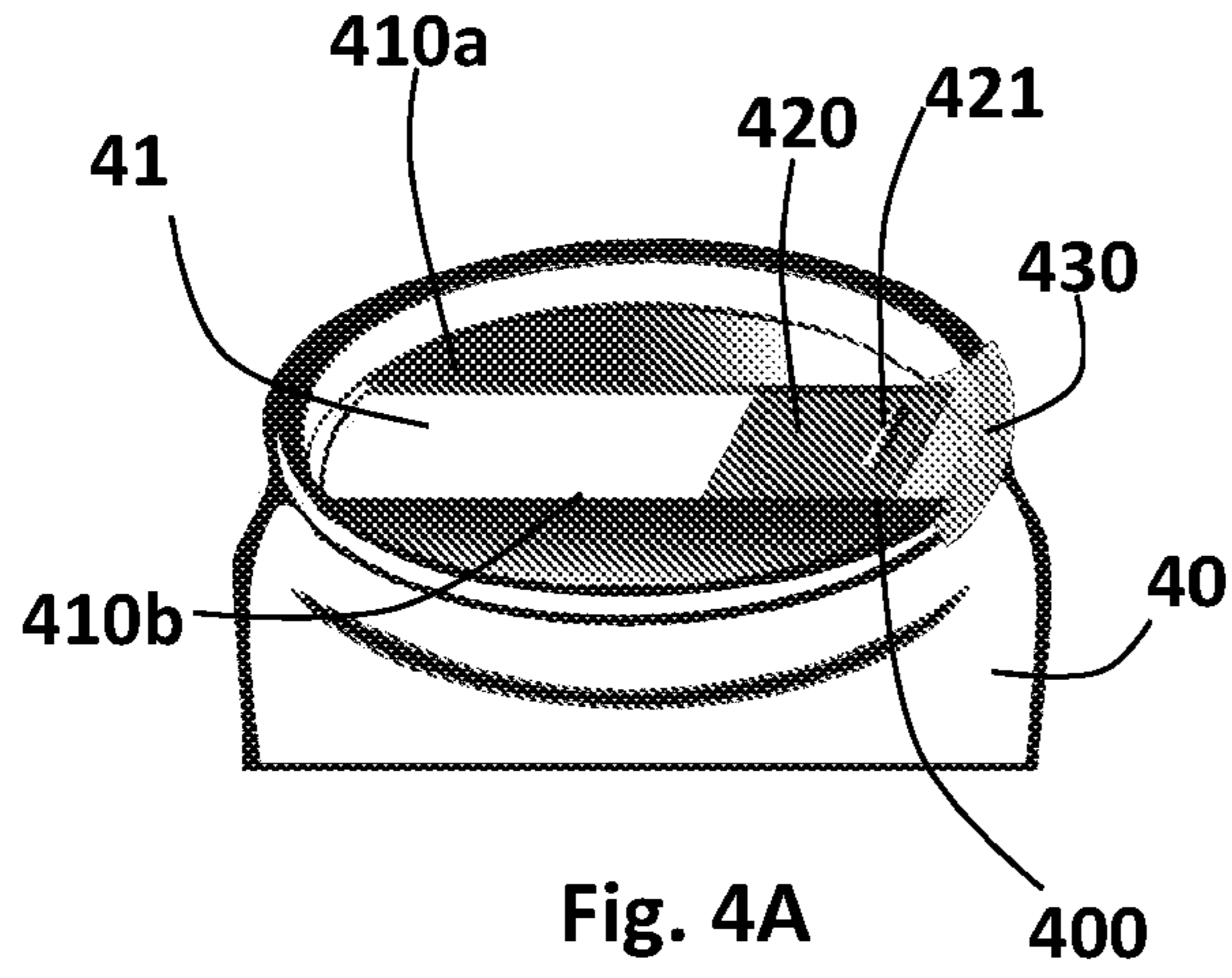

Fig. 3E



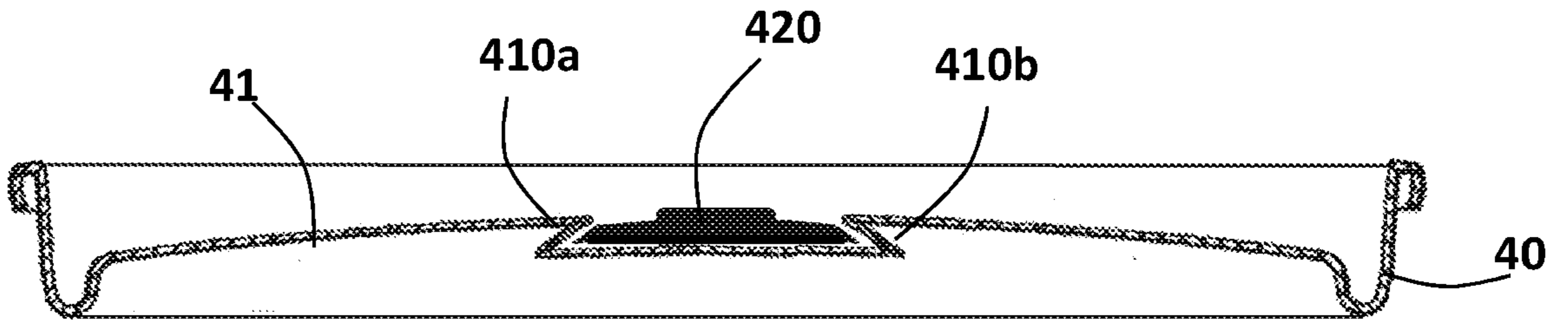

Fig. 4E

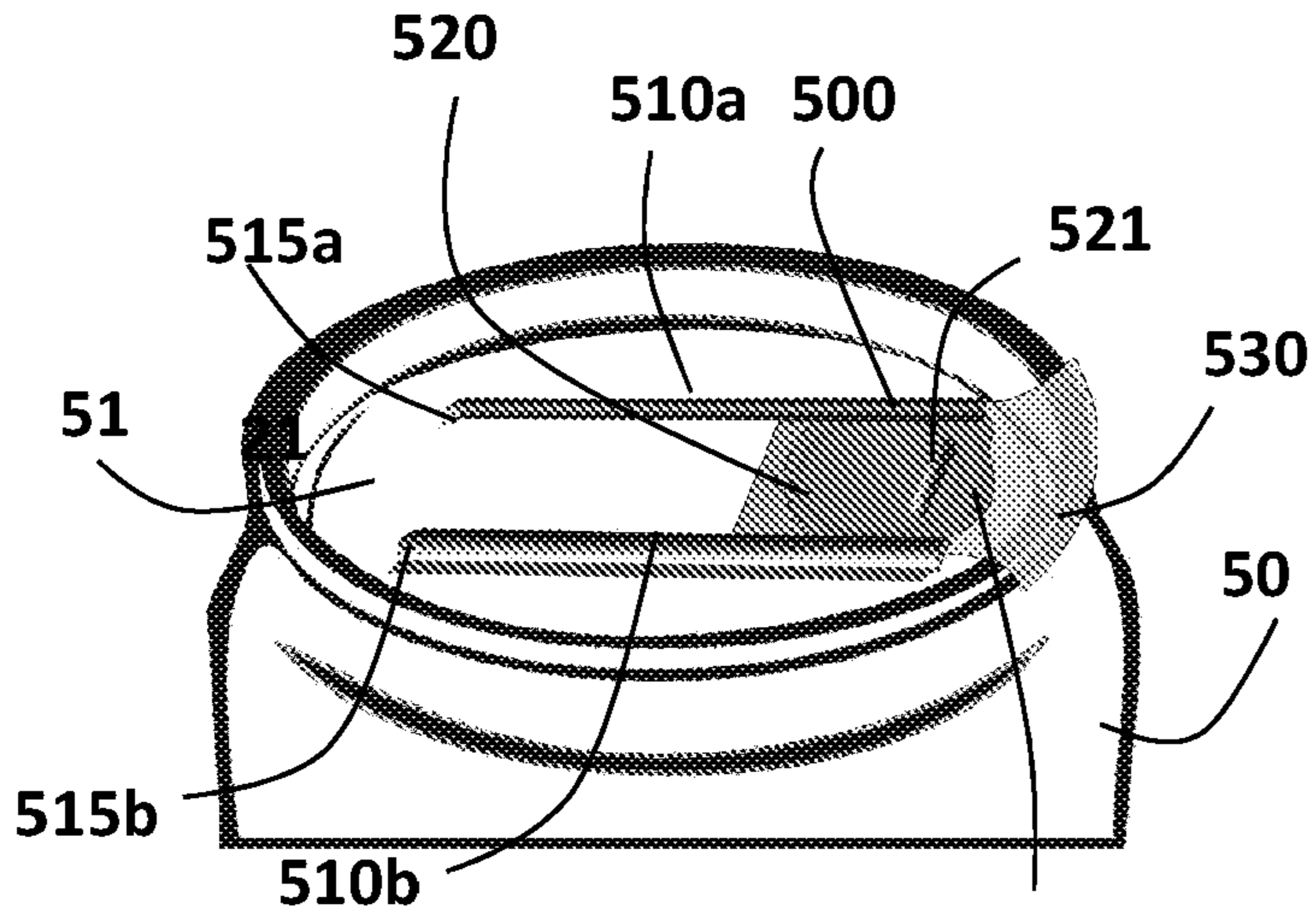

Fig. 5A

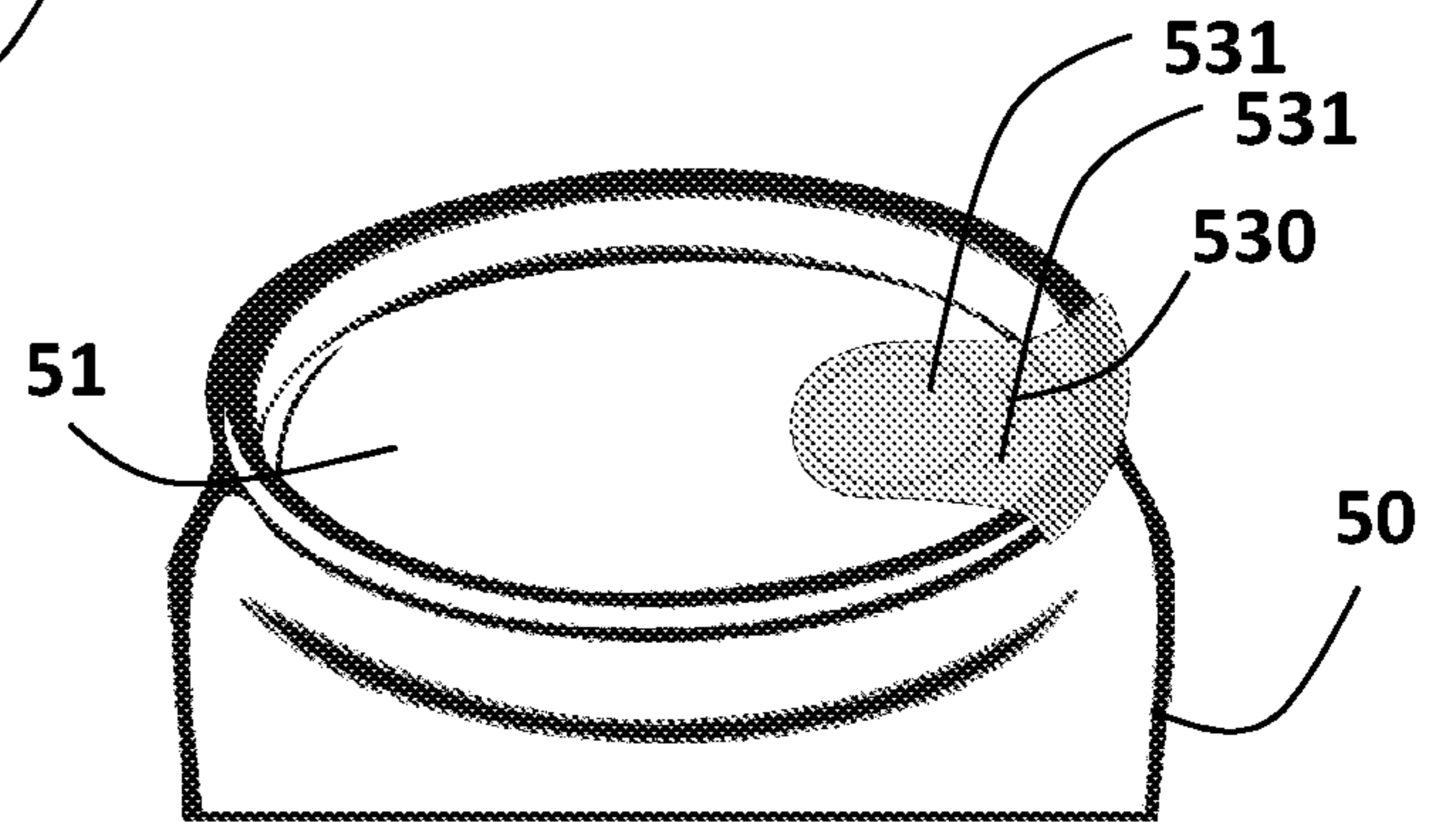

Fig. 5B

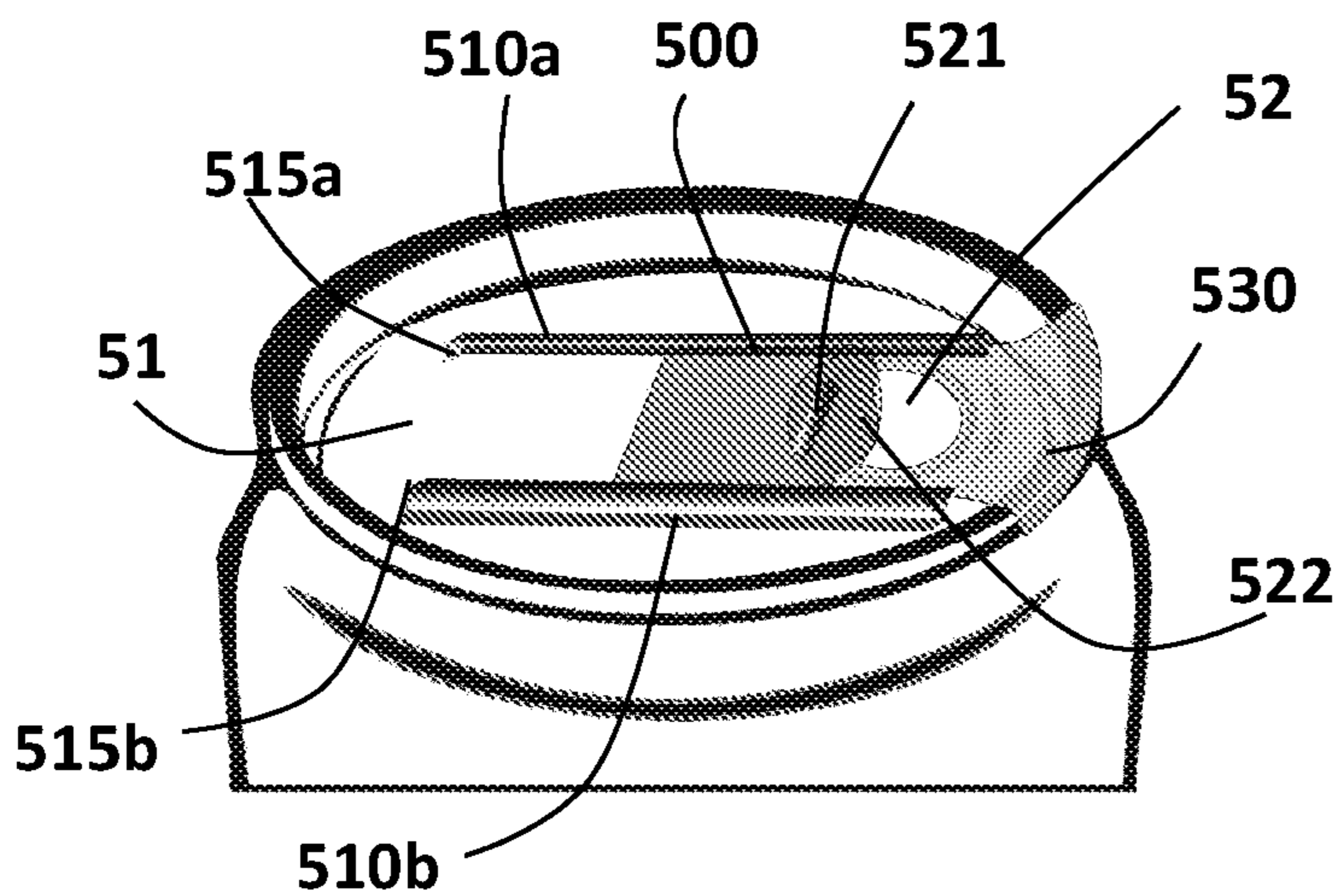

Fig. 5C

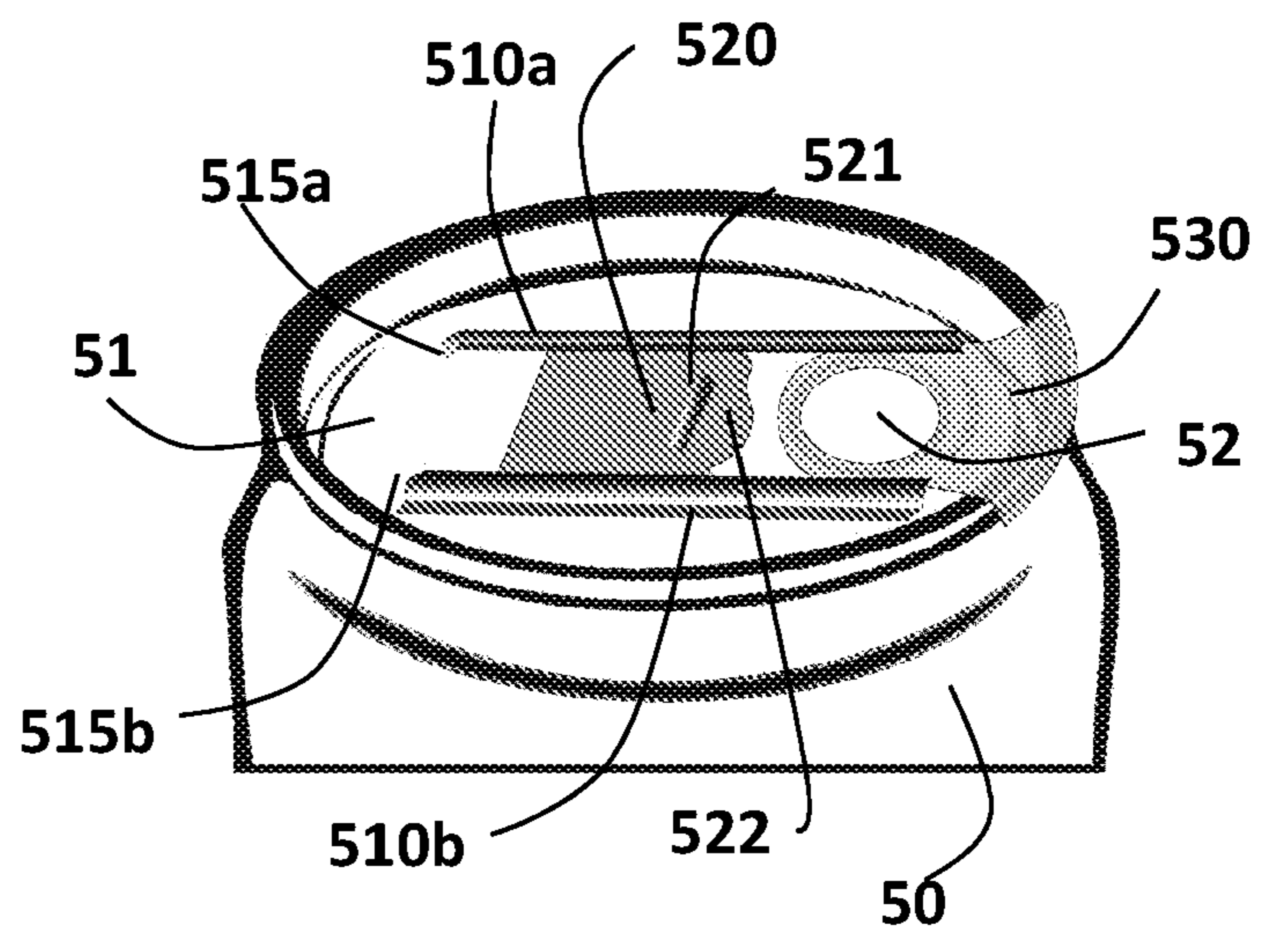

Fig. 5D

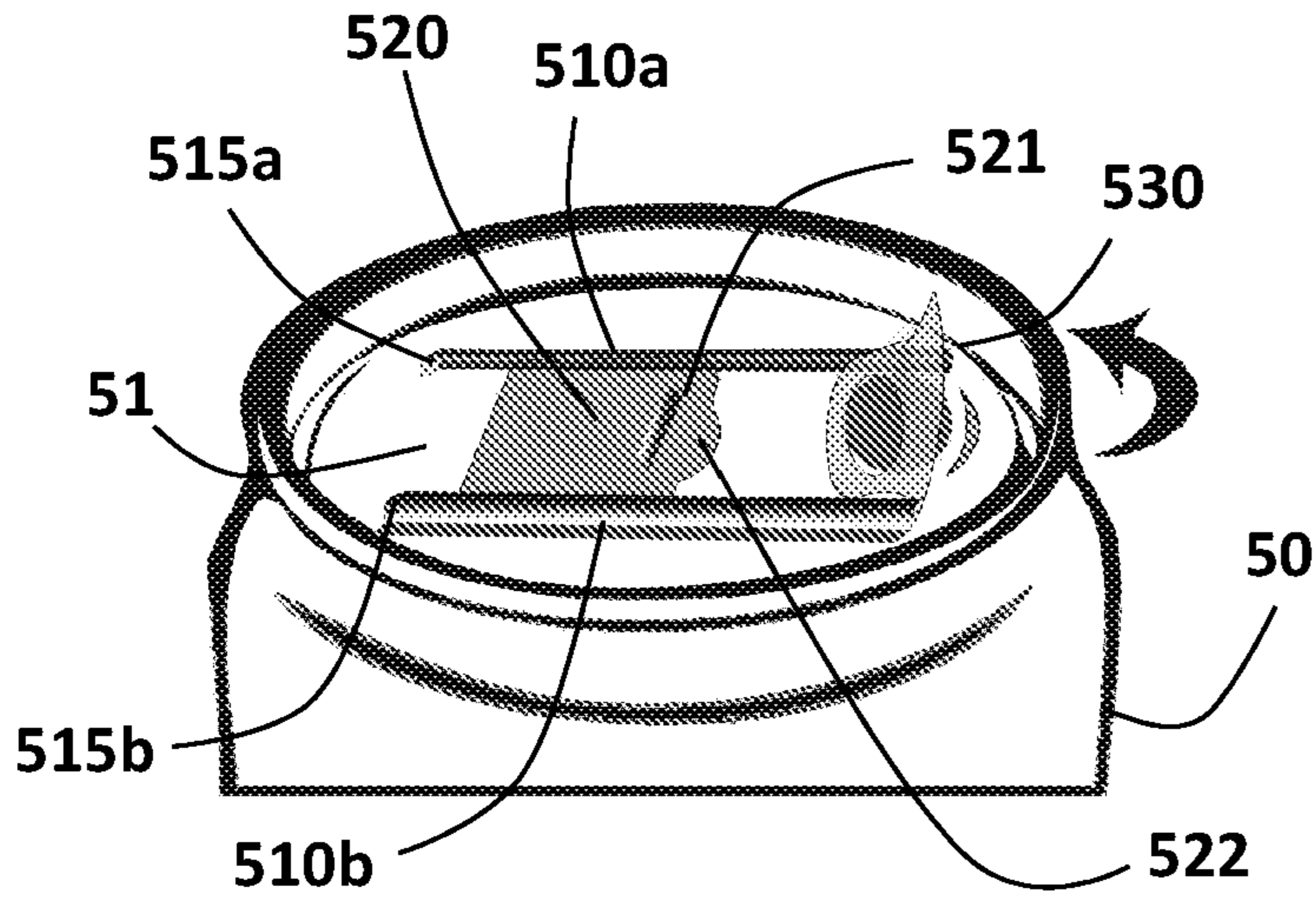

Fig. 5E

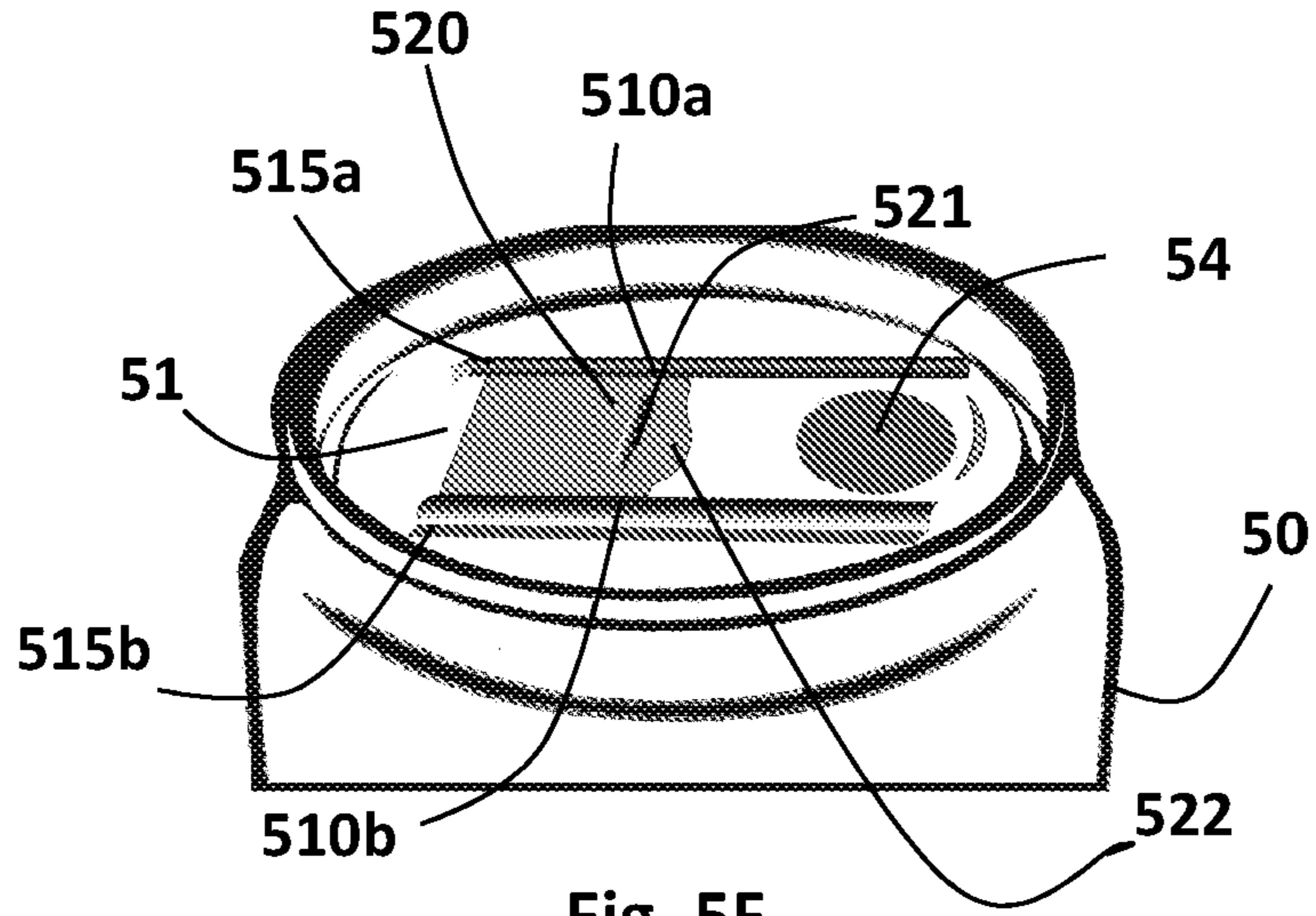

Fig. 5F

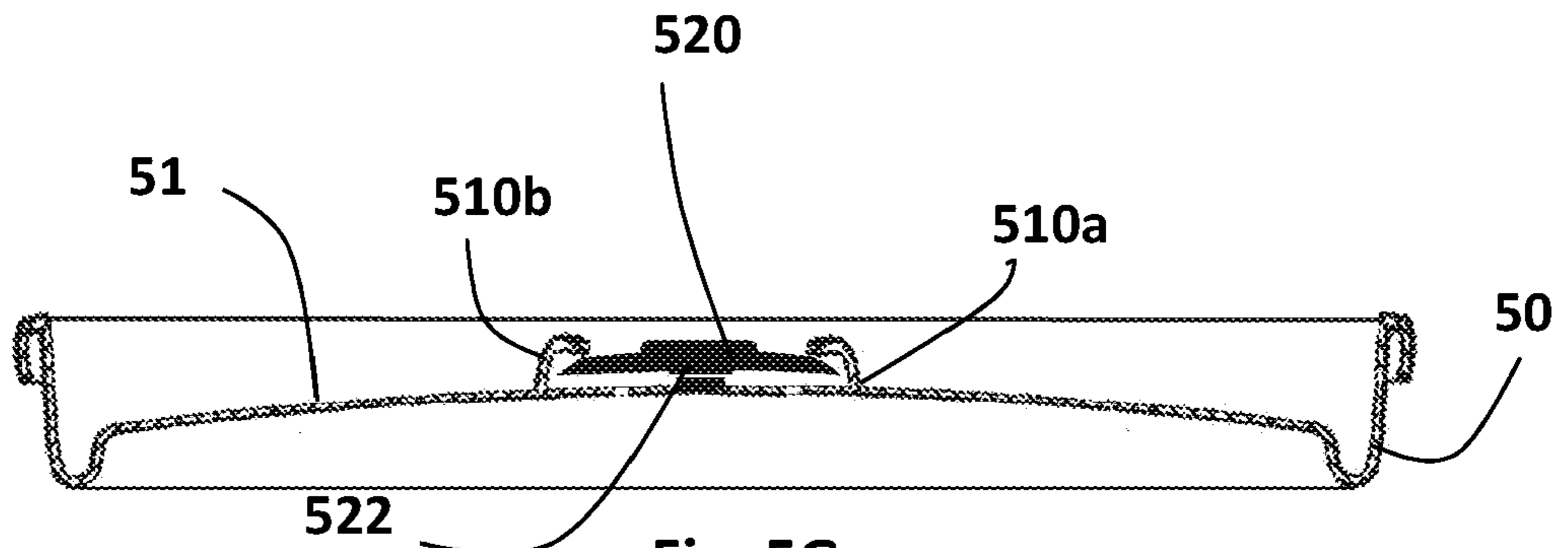

Fig. 5G

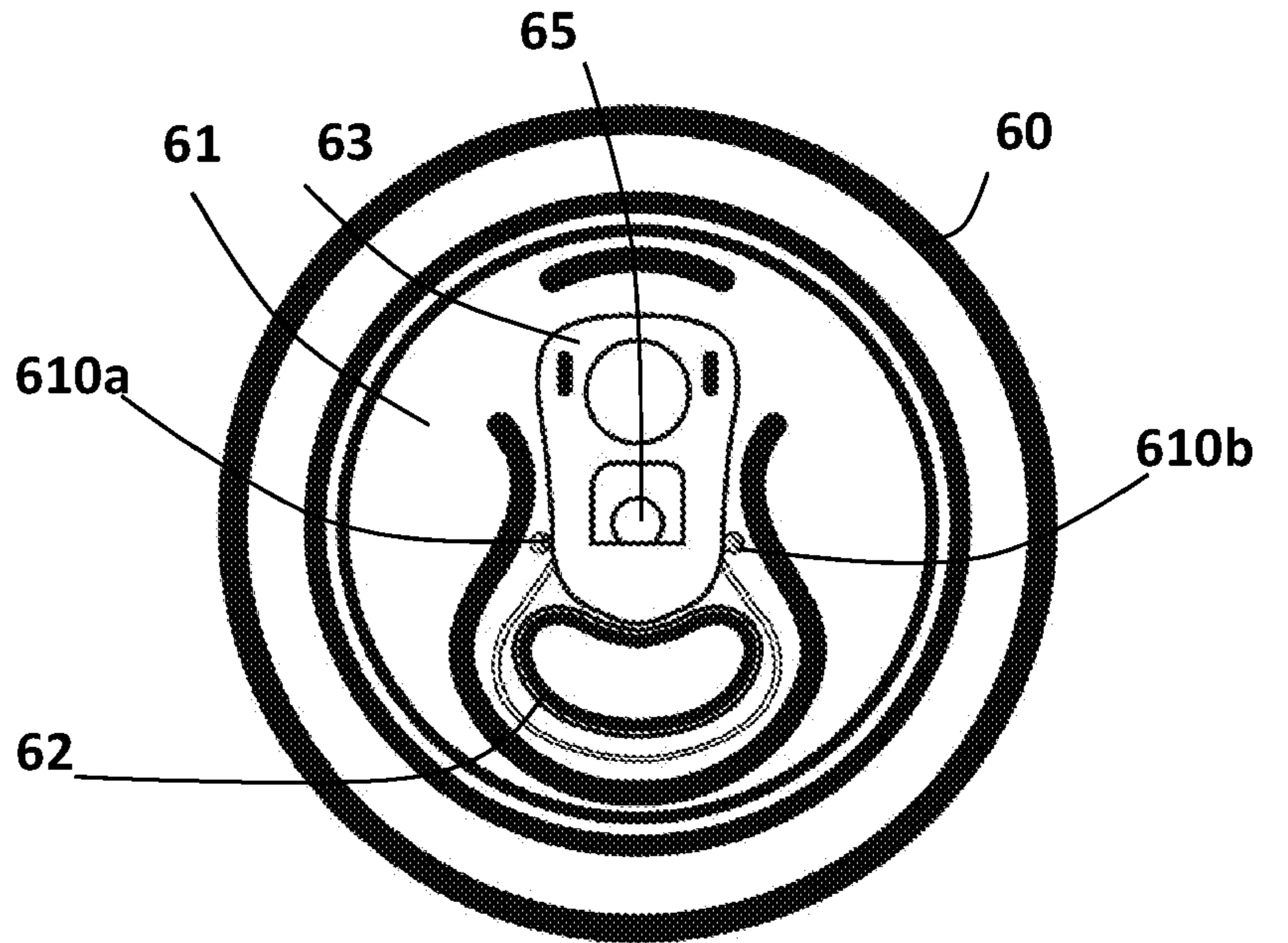

Fig. 6A

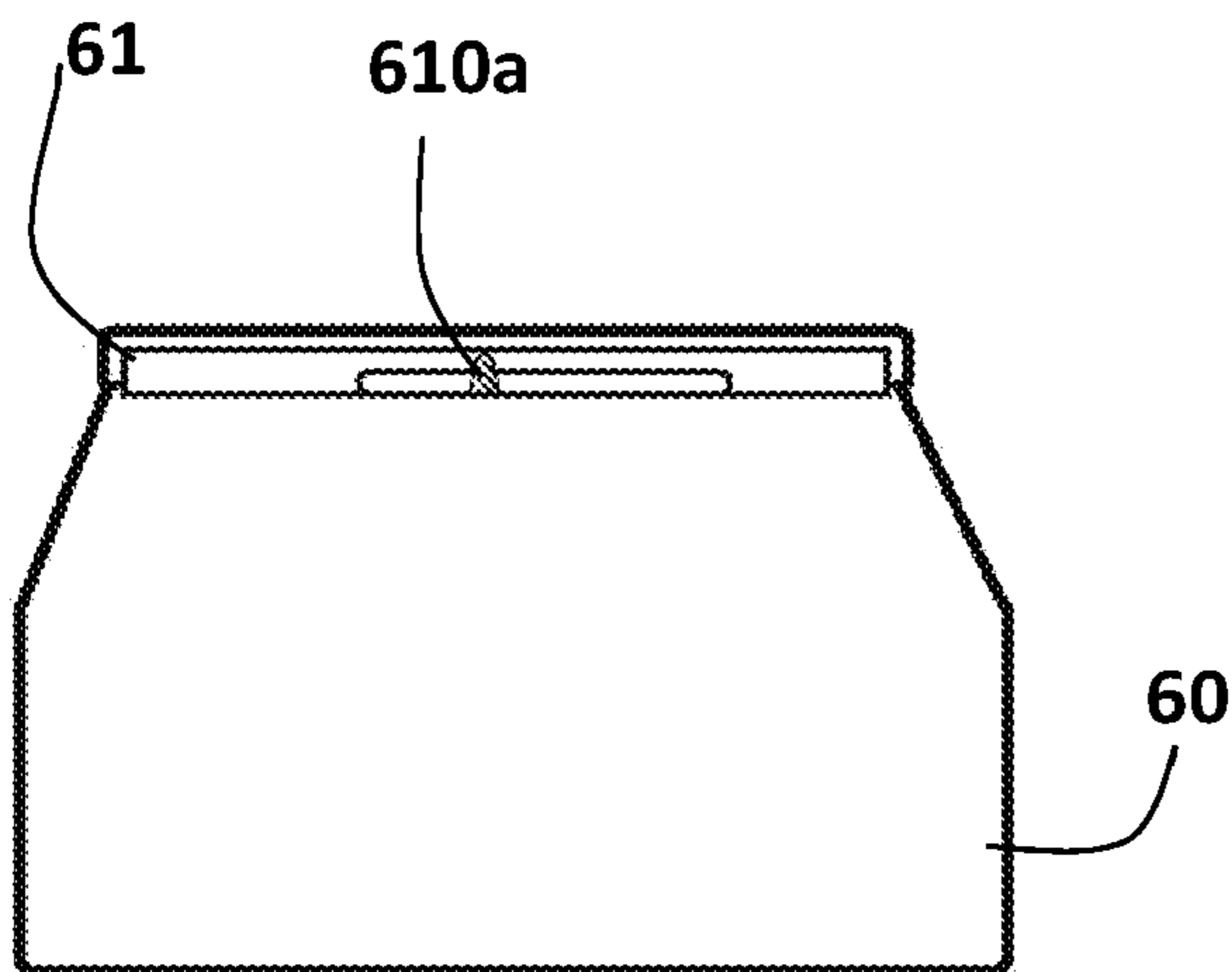

Fig. 6B

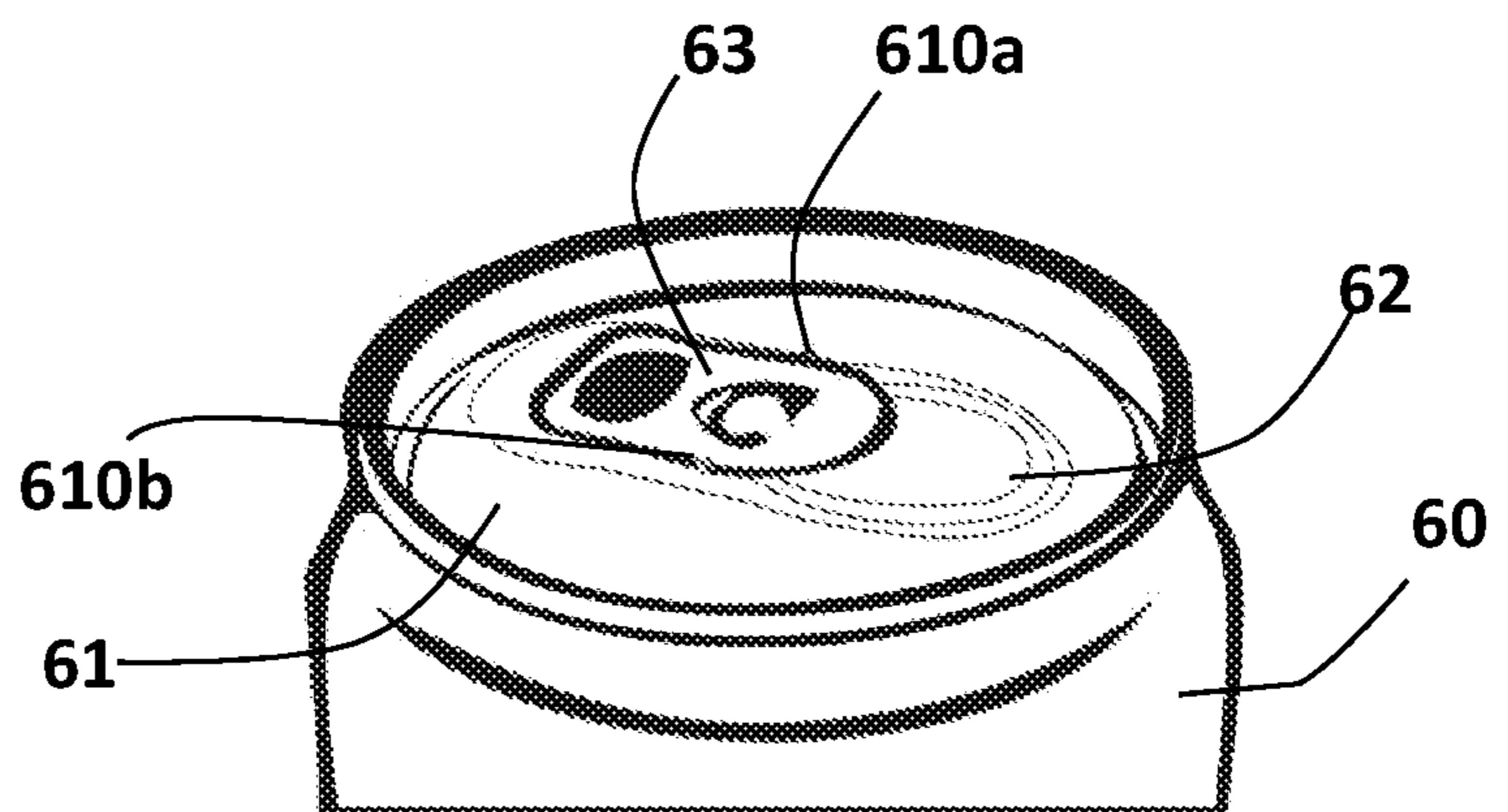

Fig. 6C

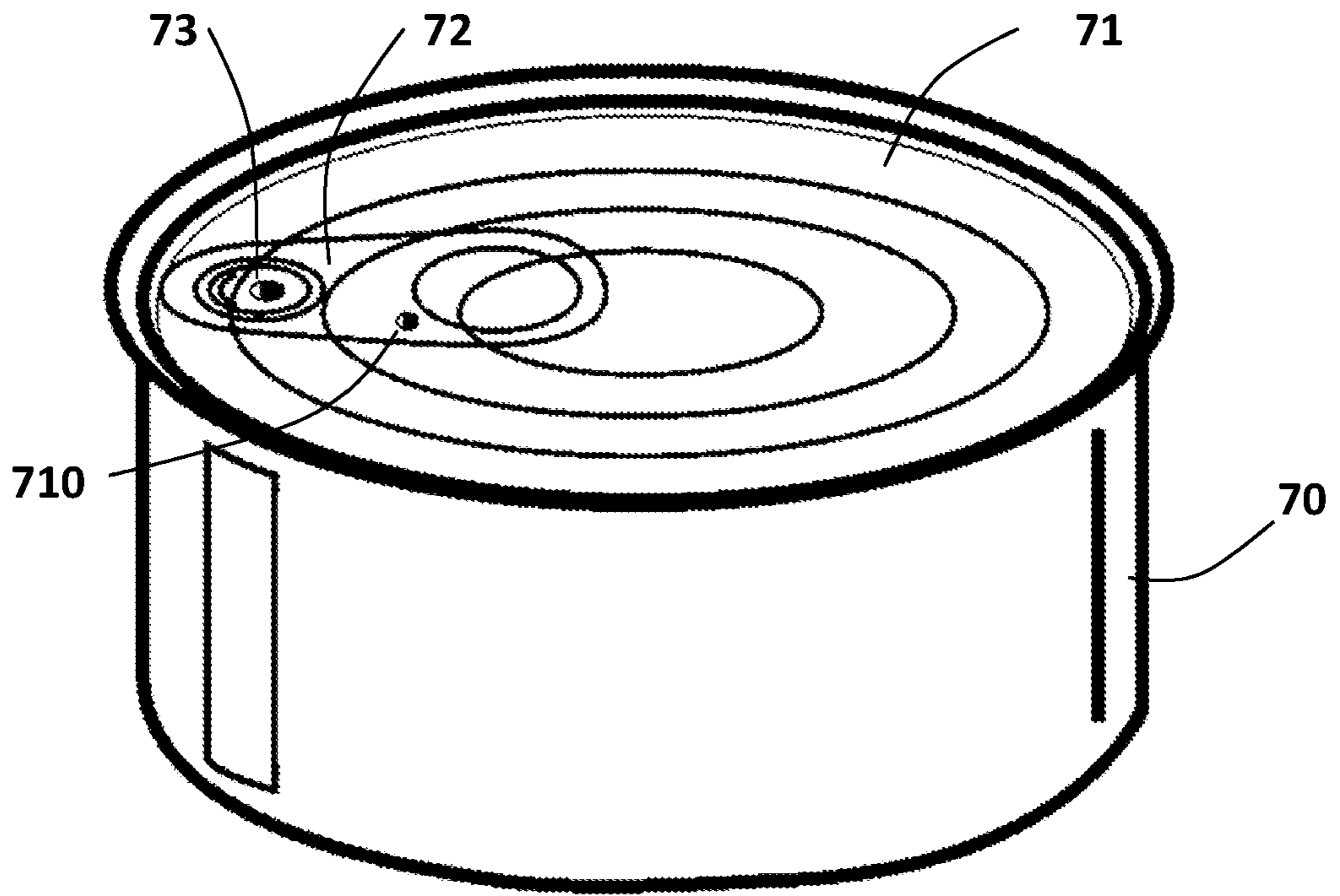

Fig. 7

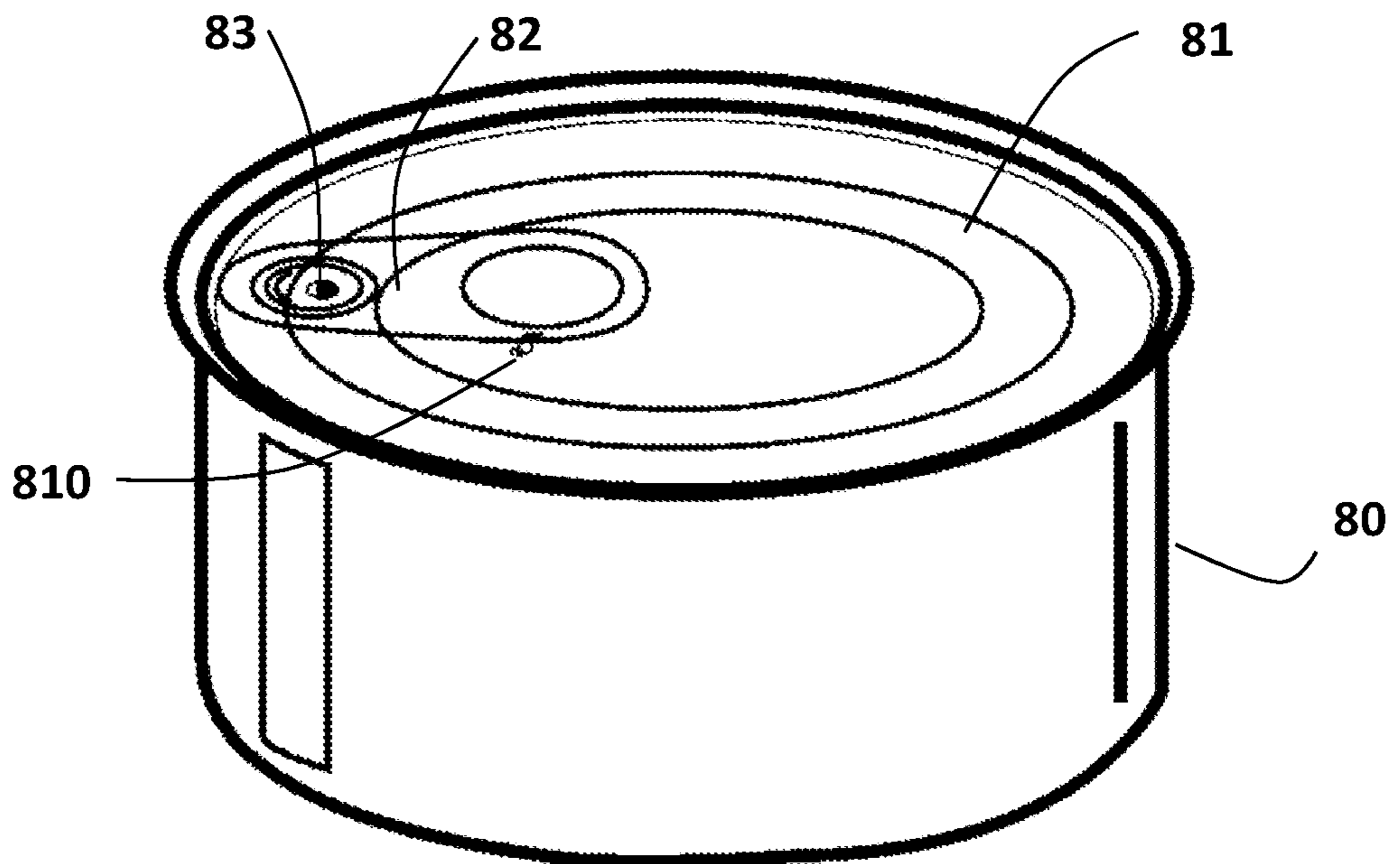

Fig. 8

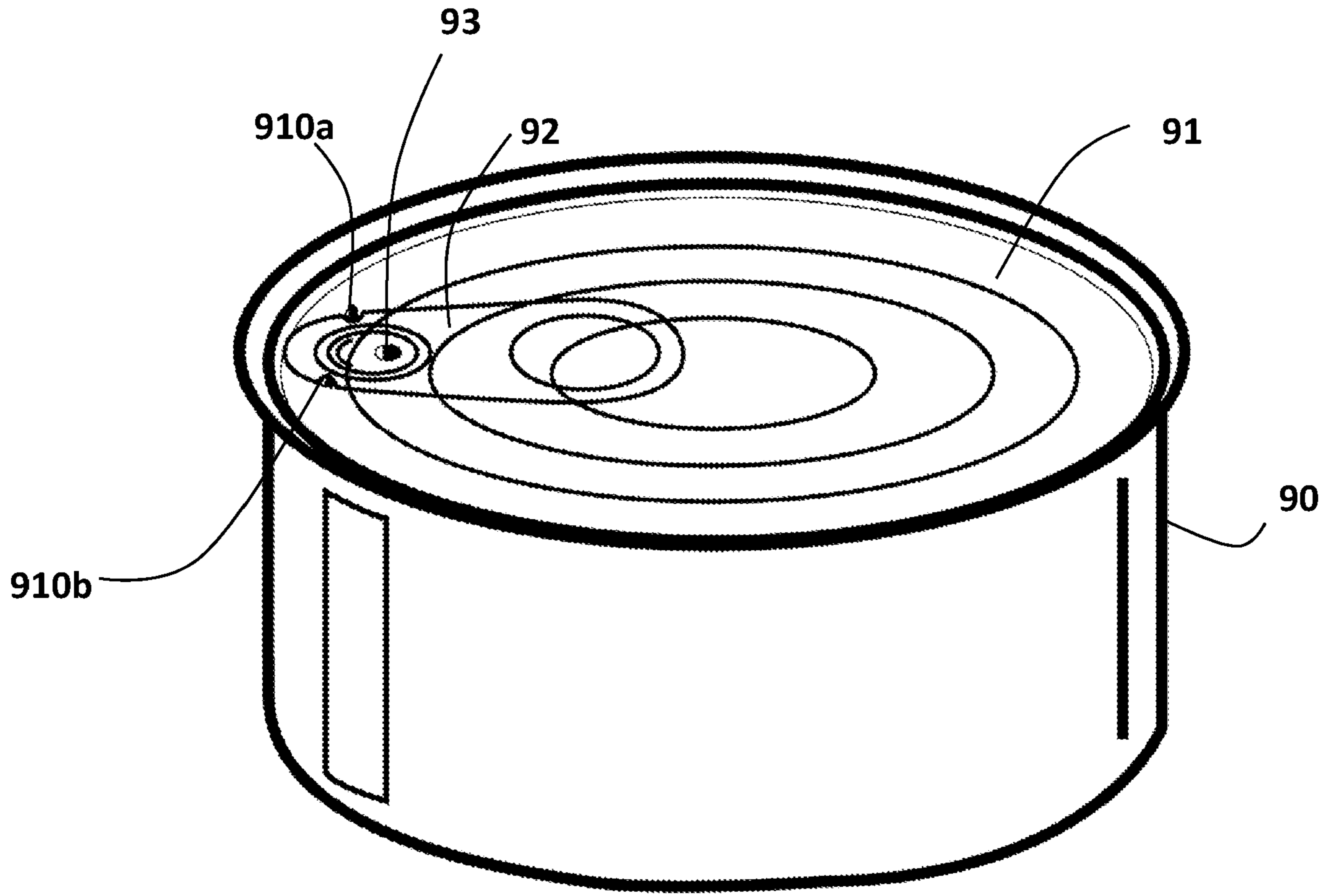

Fig. 9

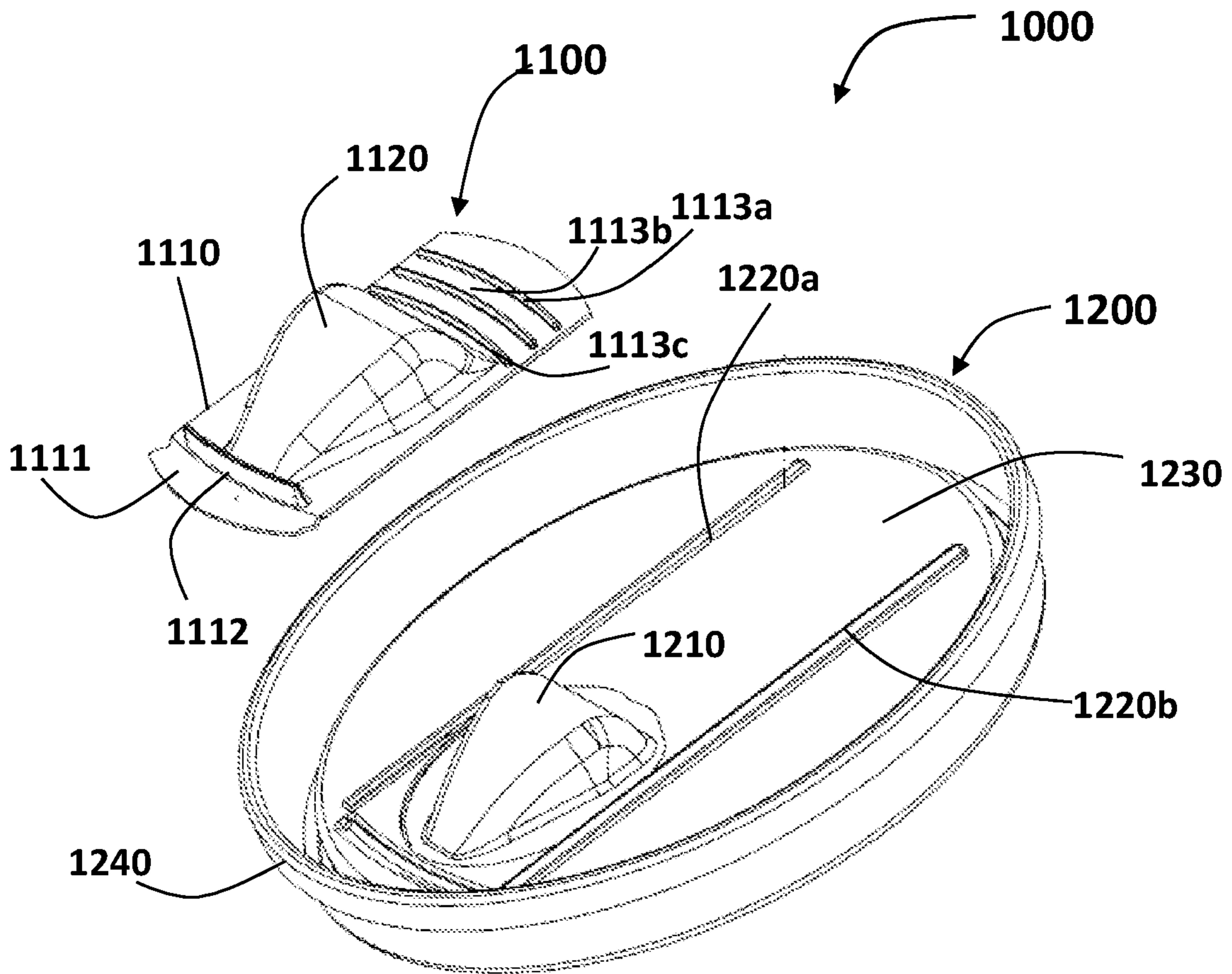

Fig. 10A

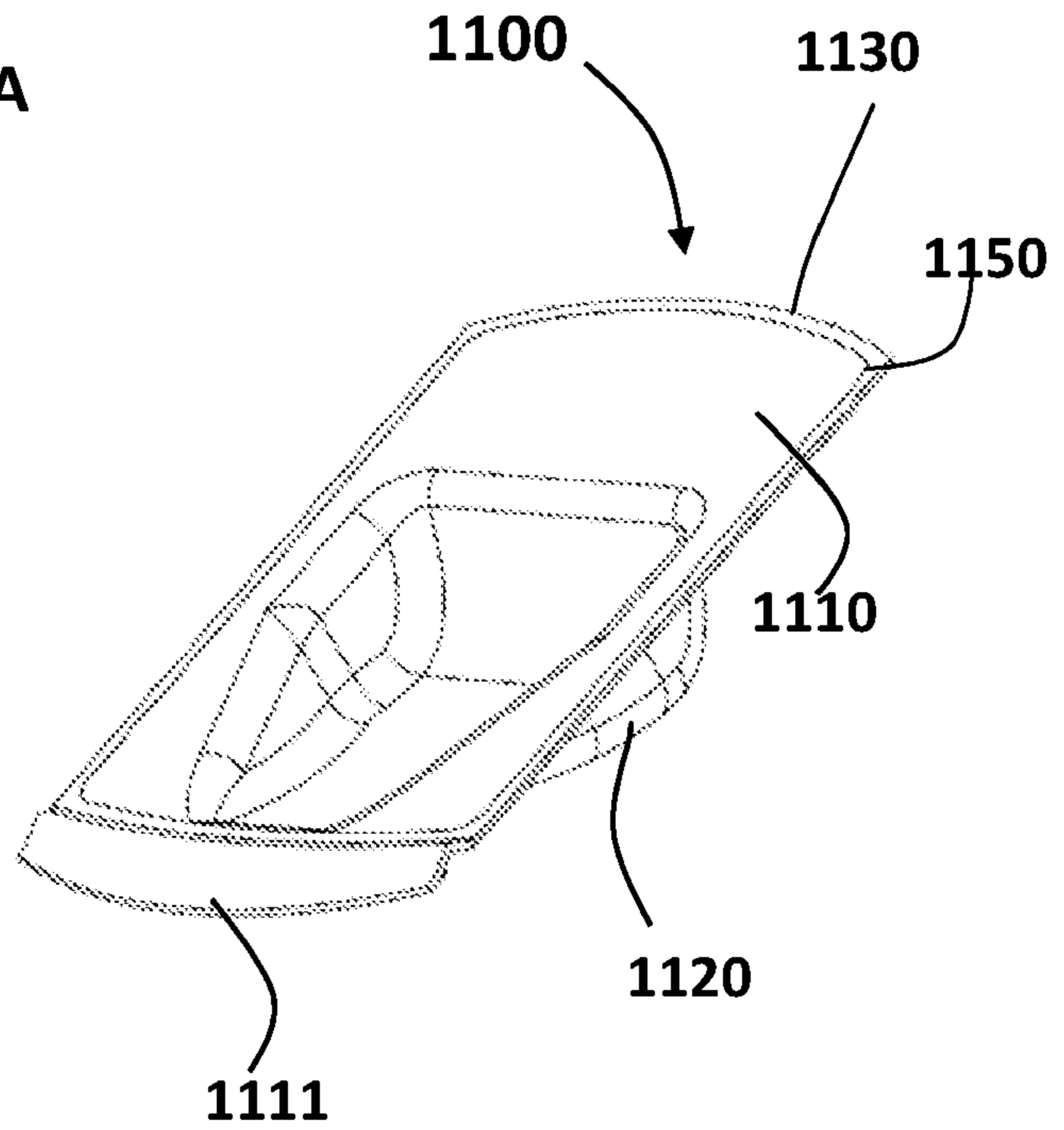

Fig. 10B

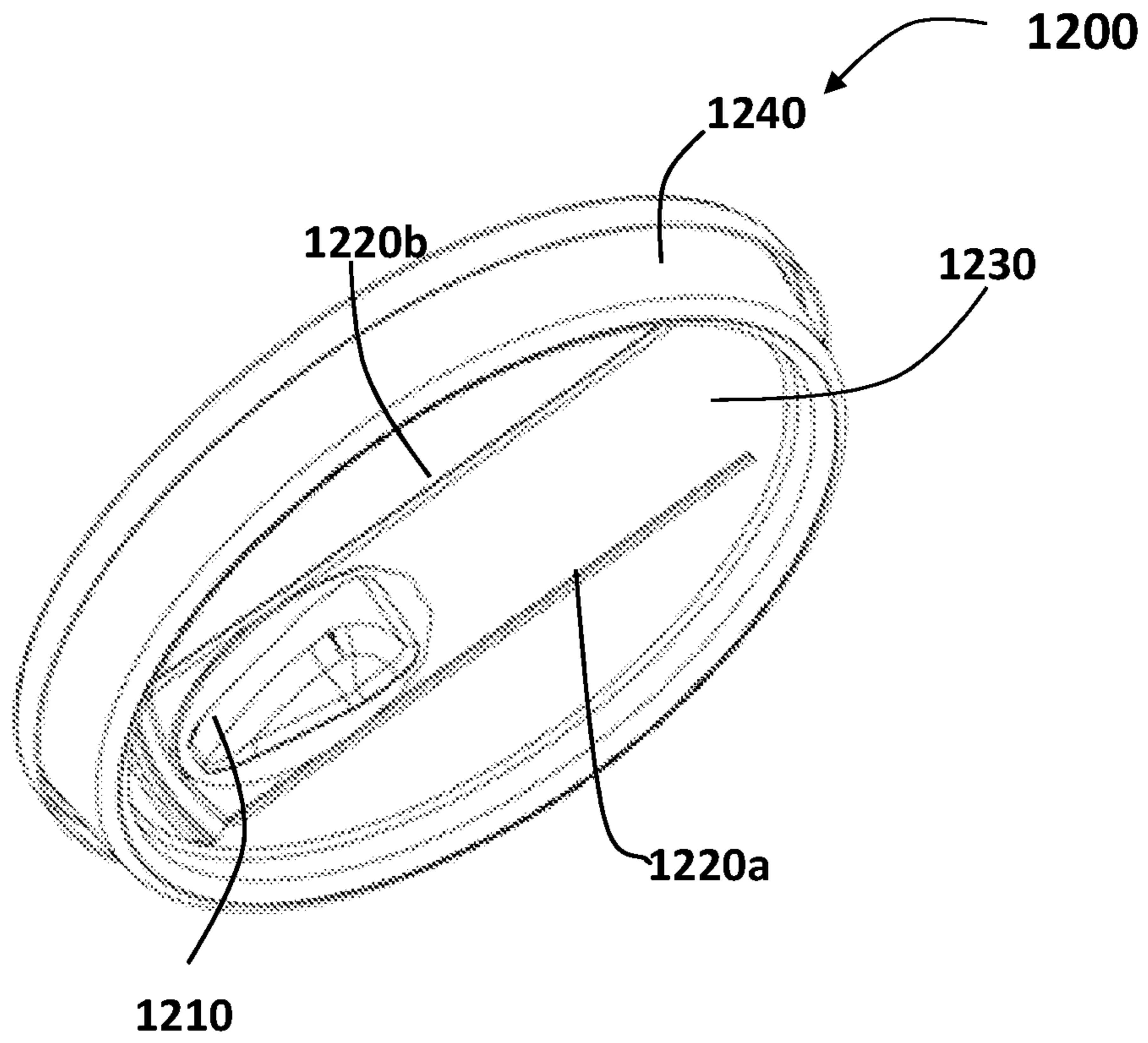

Fig. 10C

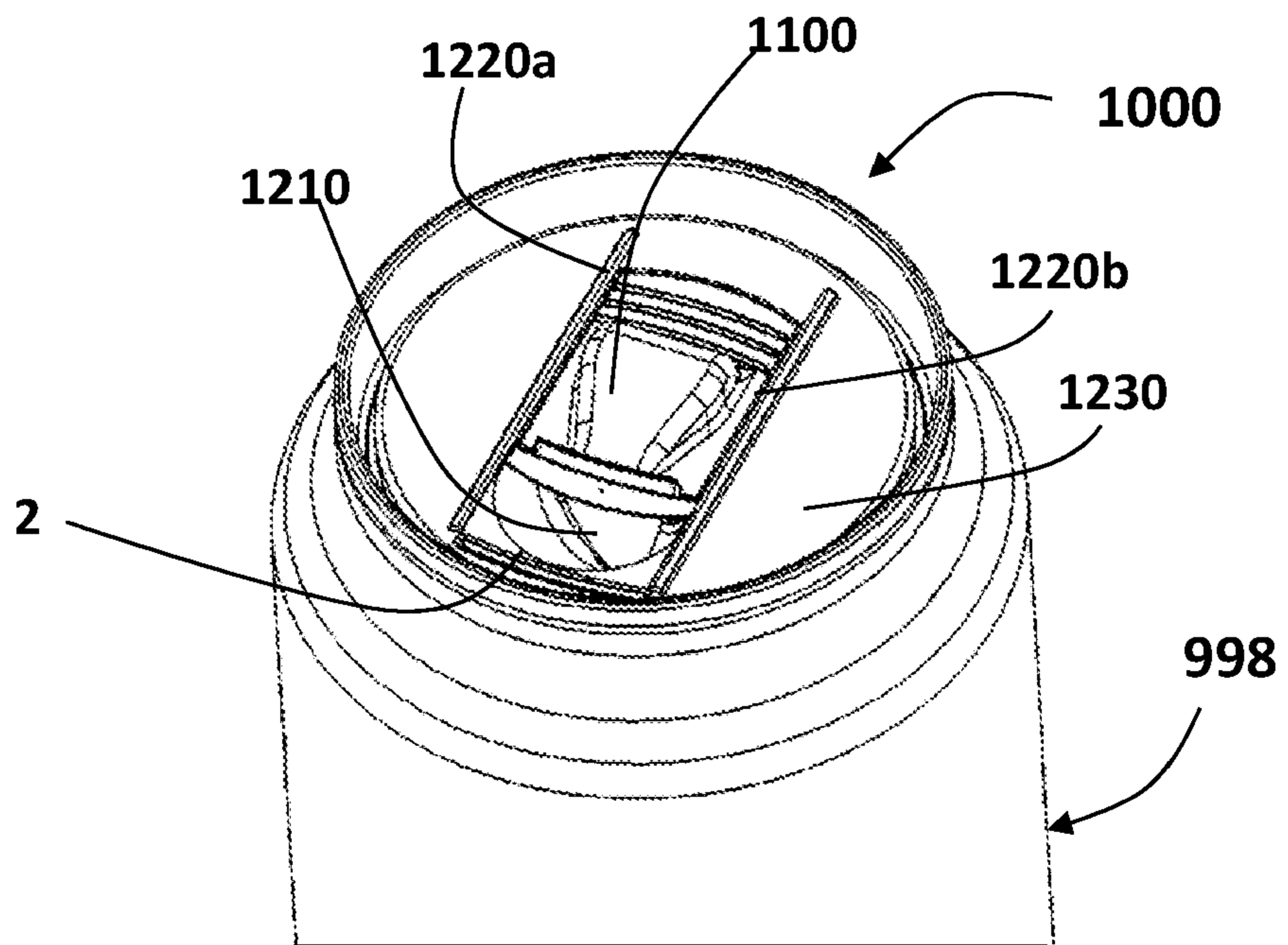

Fig. 10D

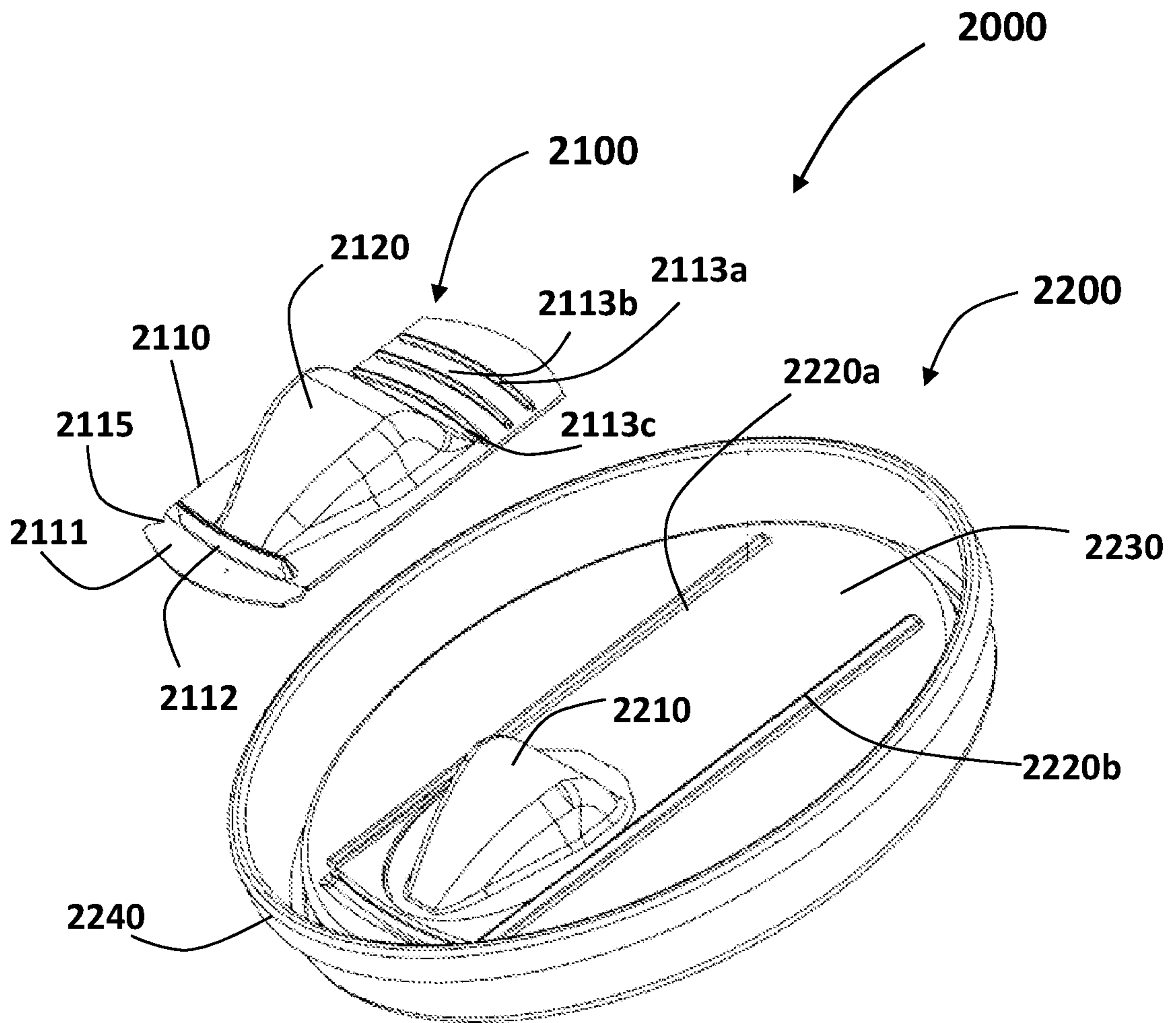

Fig. 11A

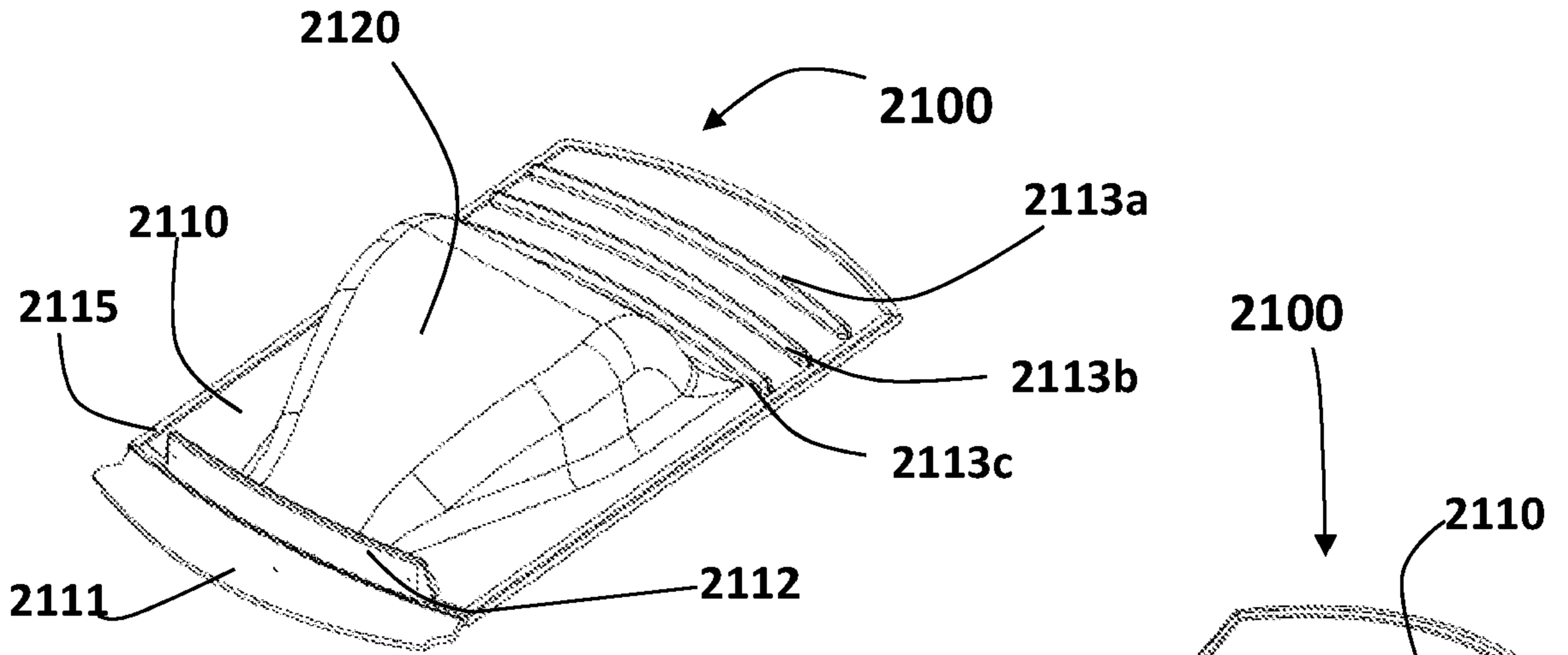

Fig. 11B

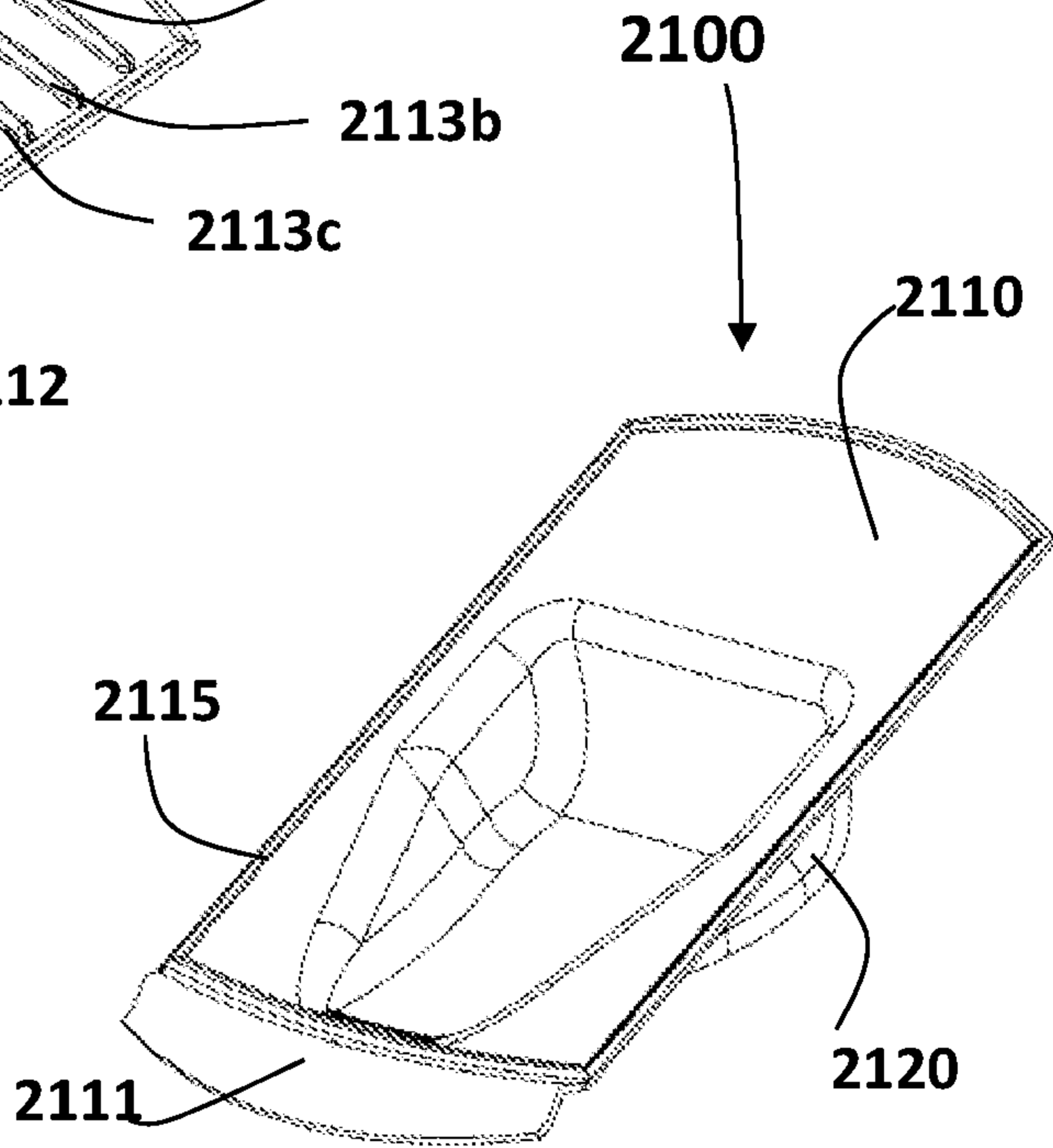

Fig. 11C

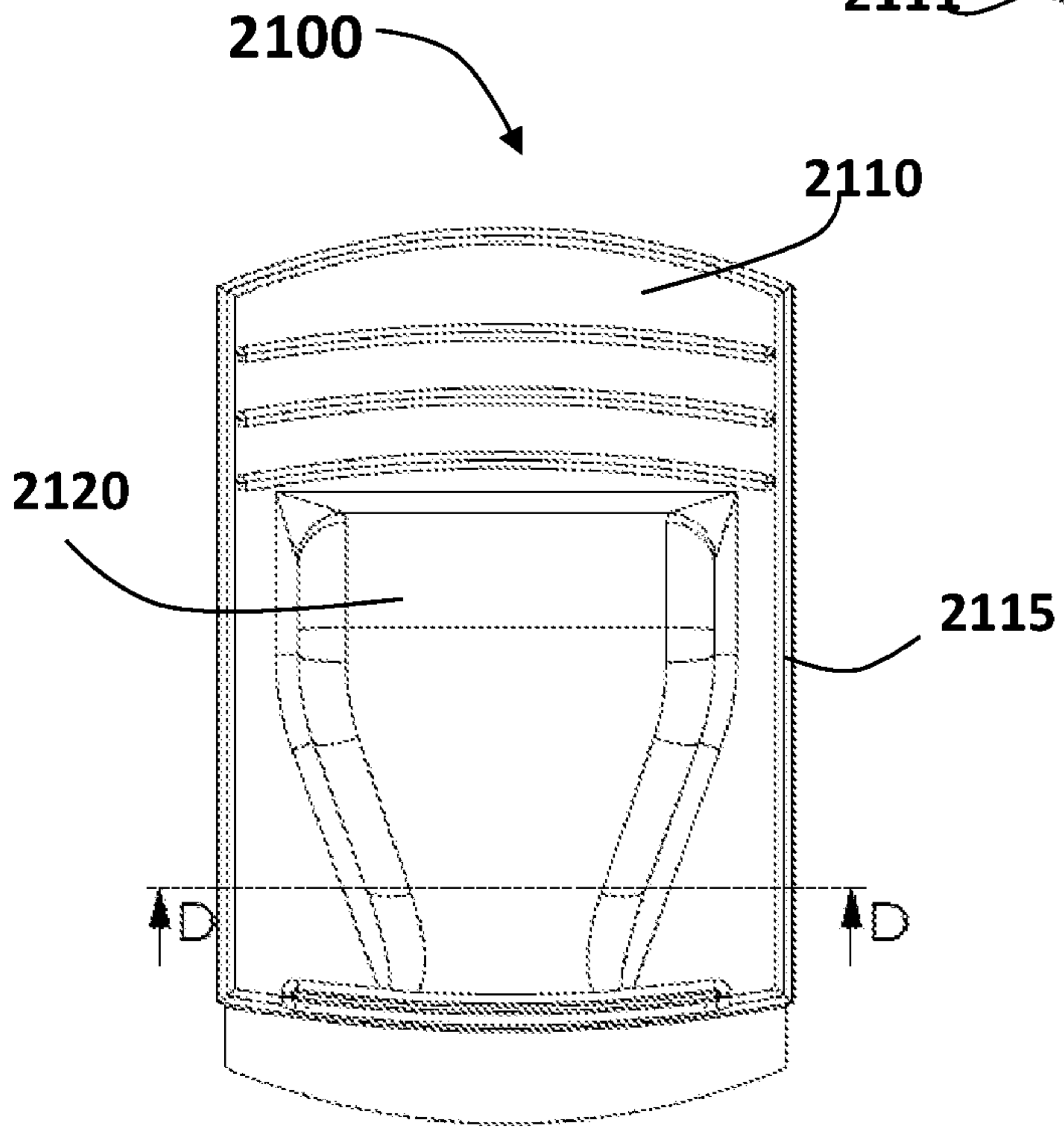

Fig. 11D

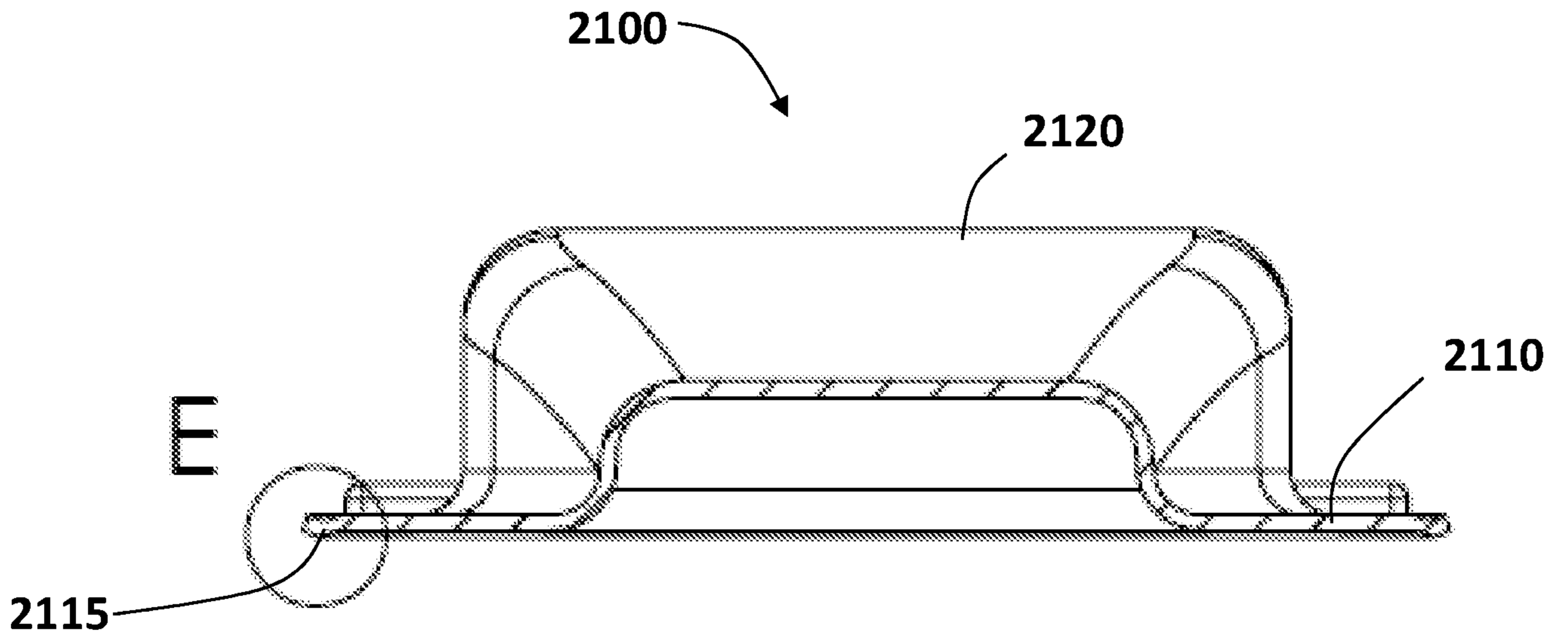

Fig. 11E

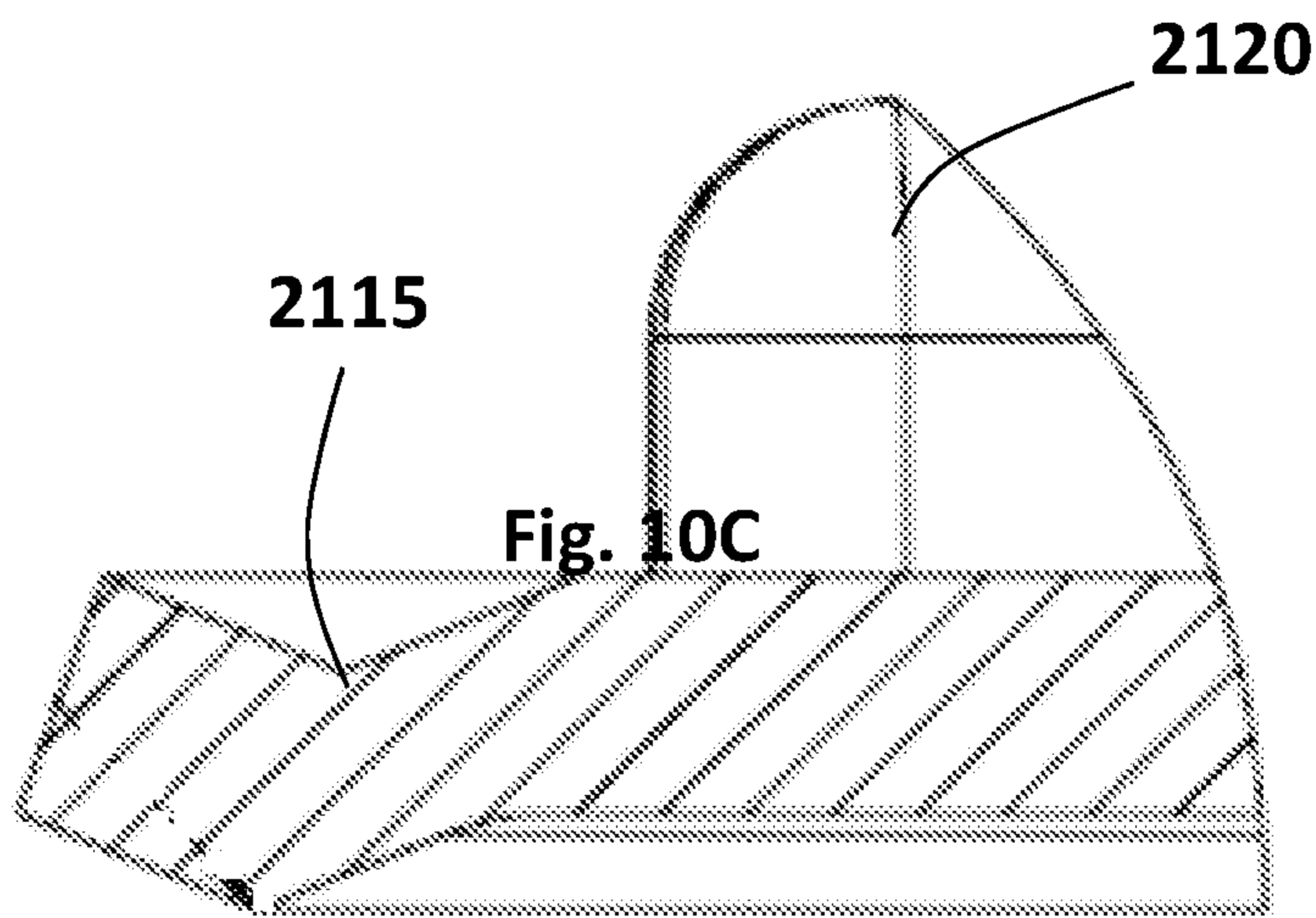
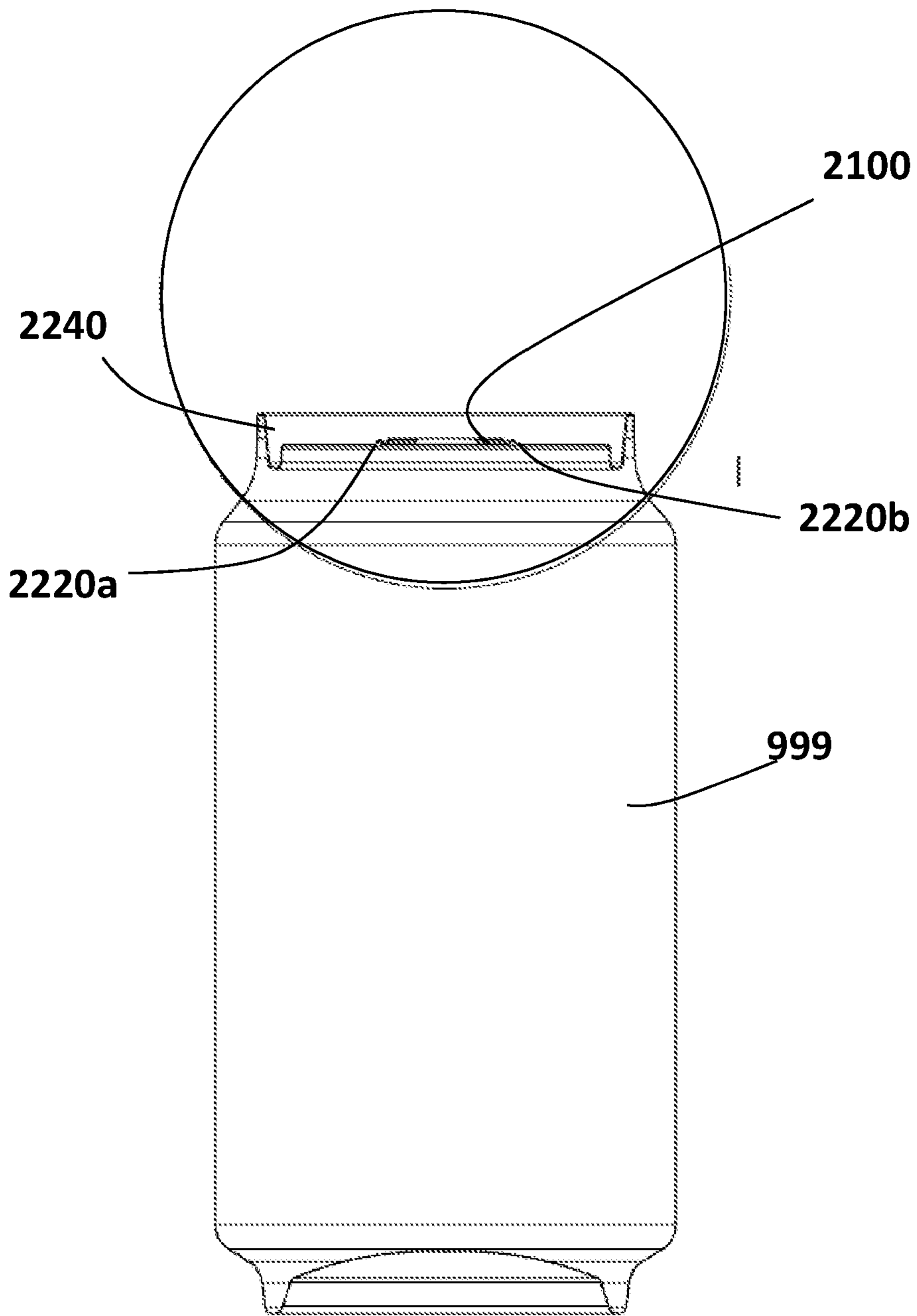

Fig. 11F



SCALE 1.5 : 1

**Fig. 11G**

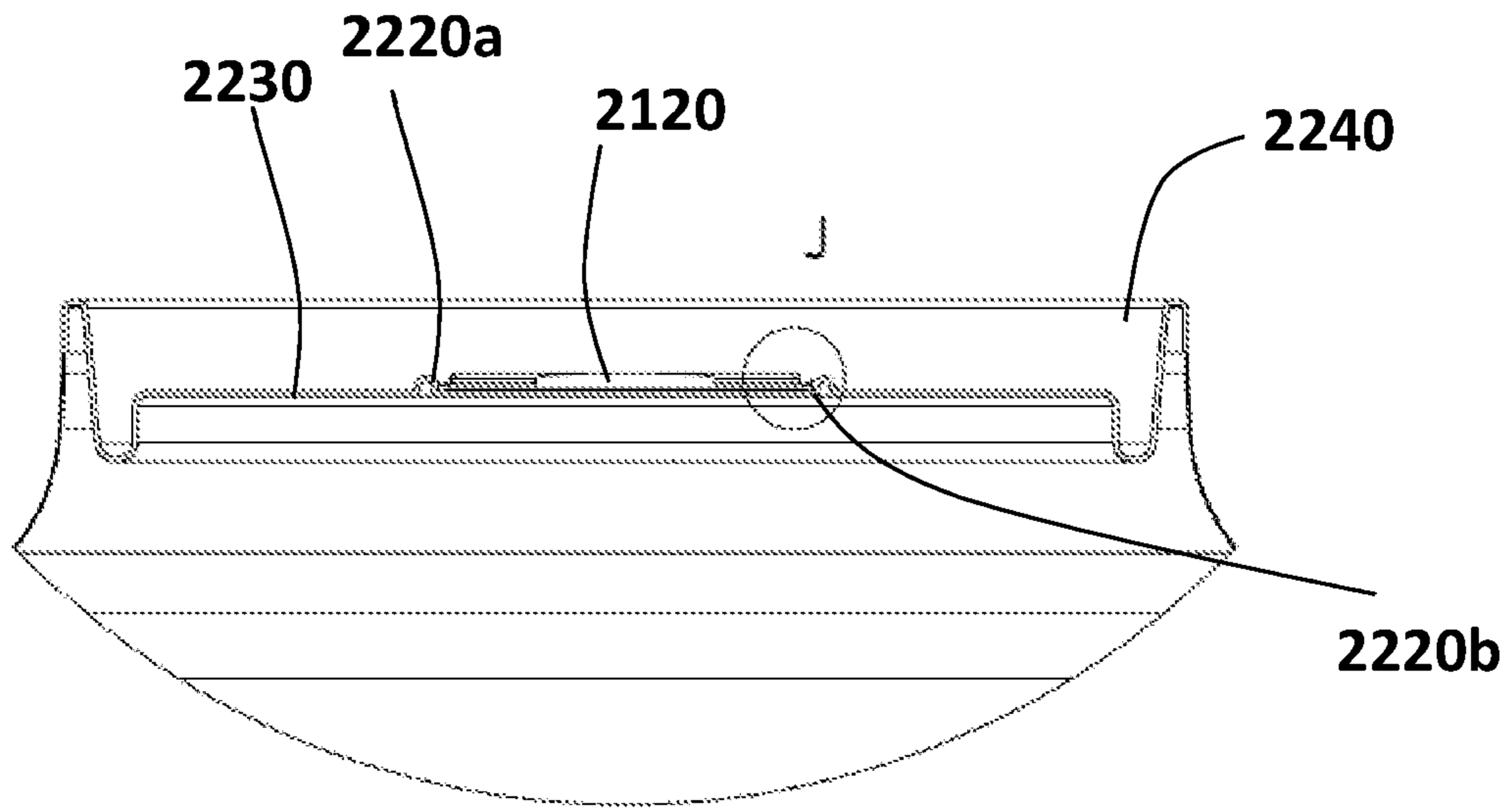

Fig. 11H

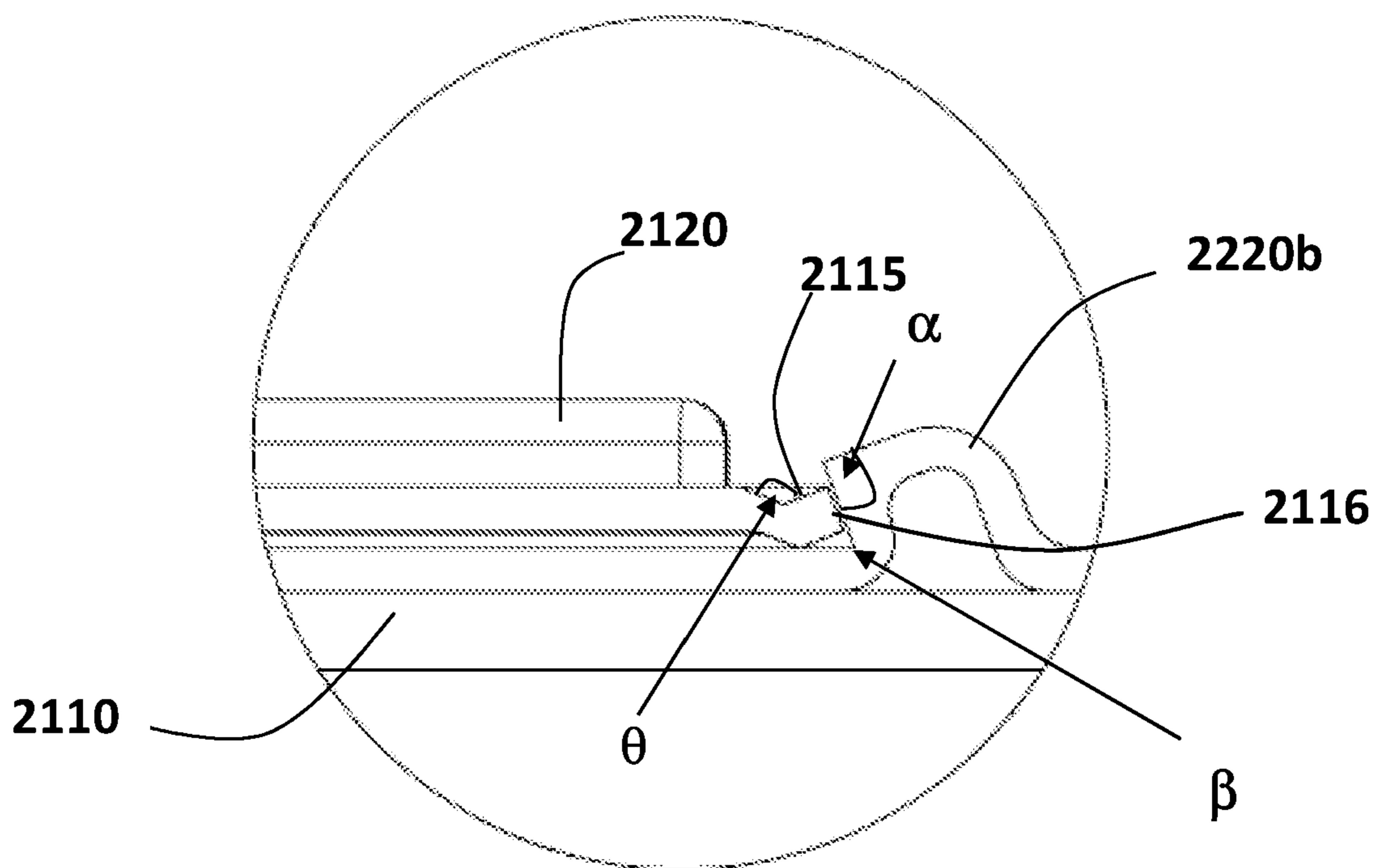

Fig. 11I

