

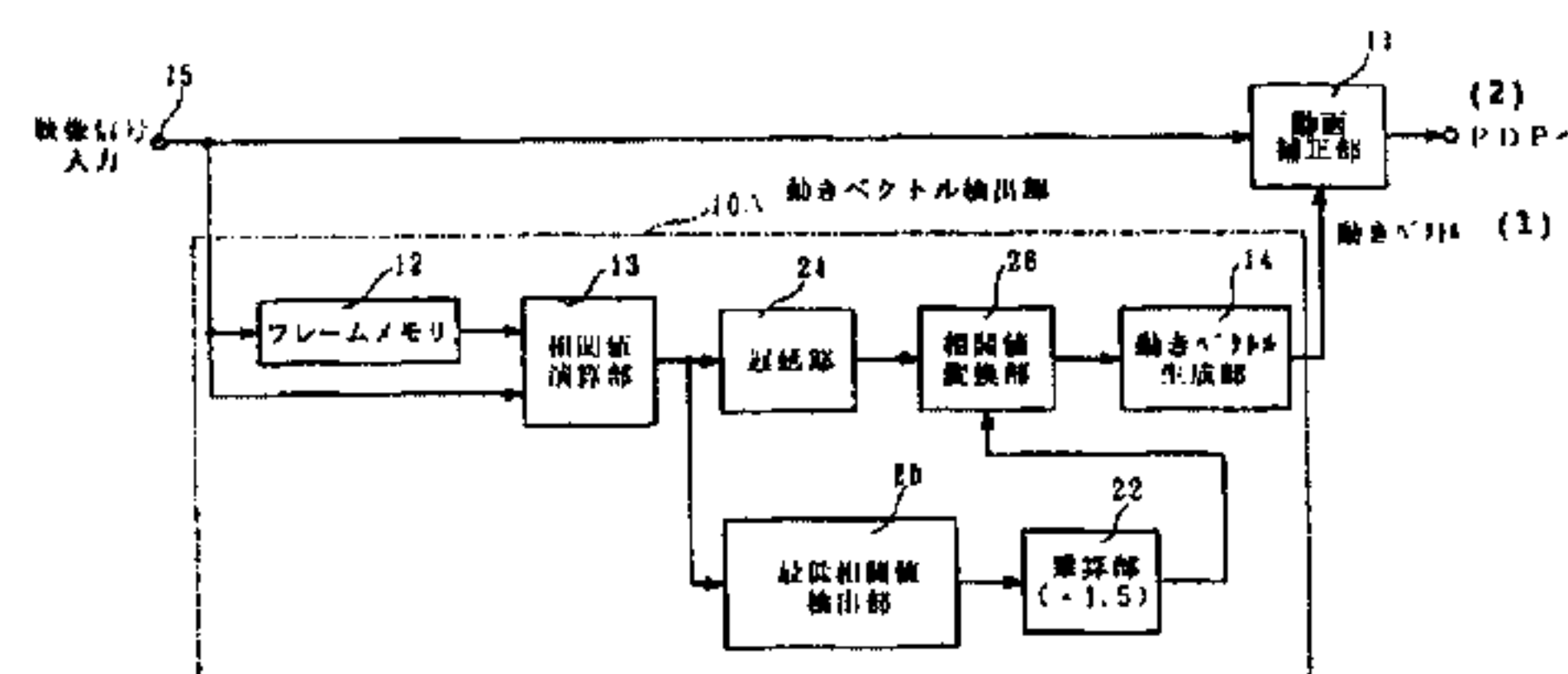

(72) KOBAYASHI, MASAYUKI, JP  
(72) NAKAJIMA, MASAMICHI, JP  
(72) DENDA, HAYATO, JP  
(71) FUJITSU GENERAL LIMITED, JP  
(51) Int.Cl.<sup>6</sup> G09G 3/28, G06T 7/20  
(30) 1997/03/06 (9/69295) JP  
(30) 1997/03/28 (9/94902) JP  
(30) 1997/07/25 (9/213954) JP

(54) **CIRCUIT DE CORRECTION D'IMAGES ANIMEES POUR  
AFFICHEUR**

(54) **MOVING PICTURE CORRECTING CIRCUIT OF DISPLAY**



10A ... moving vector detecting unit  
11 ... moving picture correcting unit  
12 ... frame memory  
13 ... correlation factor calculating unit  
14 ... moving vector generating unit  
15 ... video signal input  
20 ... lowest correlation factor detecting unit  
22 ... multiplying unit  
24 ... delaying unit  
26 ... correlation factor converting unit  
(1) ... moving vector  
(2) ... to PDP

(57) Un vecteur de mouvement entre images est détecté par une unité de détection de vecteurs de mouvement et les positions d'affichage de sous-ensembles de pixels d'un bloc sont corrigées au moyen d'une unité de correction d'images animées conformément aux valeurs de détection du vecteur de mouvement. La qualité d'image n'est pas dégradée par la correction. De manière à ne pas produire de vecteur de mouvement erroné, un facteur de corrélation S1 minimum détecté par une unité de détection (20) du facteur de corrélation minimum est multiplié par 1,5, les facteurs de corrélation qui ne sont pas supérieurs à S1 sont remplacés par S2 ( $S2 < S1$ ), et, parmi une pluralité de blocs associés aux facteurs de corrélation S2, le bloc le plus proche de l'origine sert de point de départ du vecteur de mouvement. De manière à ne pas entrer un vecteur de mouvement erroné dans l'unité de correction d'images animées, un vecteur de mouvement est déterminé par décision liée à la majorité des vecteurs de mouvement des blocs environnants. Le mouvement d'une ligne possède la première priorité (Fig. 13).

(57) A moving vector between frame is detected by a moving vector detecting unit and the display positions of the subfields of pixels in a block are corrected using a moving picture correcting unit in accordance with the detection values of the moving vector. The picture quality is not deteriorated when corrected. In order not to output an erroneous moving vector, a lowest correlation factor S1 detected by a lowest correlation factor detecting unit (20) is multiplied by 1.5, the correlation factors not larger than S1 are substituted by S2 ( $S2 < S1$ ), and, among a plurality of blocks with the correlation factors S2, the block closest to the origin is used as the starting point of the moving vector. In order not to input an erroneous moving vector to the moving picture correcting unit, a moving vector is determined by the majority decision of the moving vectors of surrounding blocks. The movement of a line has first priority (Fig. 13).





<p>(51) 国際特許分類 G09G 3/28, G06T 7/20</p>	<p>A1</p>	<p>(11) 国際公開番号 WO98/39764</p> <p>(43) 国際公開日 1998年9月11日(11.09.98)</p>
---	-----------	--

<p>(21) 国際出願番号 PCT/JP98/00888</p> <p>(22) 国際出願日 1998年3月4日(04.03.98)</p> <p>(30) 優先権データ 特願平9/69295 1997年3月6日(06.03.97) 特願平9/94902 1997年3月28日(28.03.97) 特願平9/213954 1997年7月25日(25.07.97)</p> <p>(71) 出願人 (米国を除くすべての指定国について) 株式会社 富士通ゼネラル (FUJITSU GENERAL LIMITED)[JP/JP] 〒213-0013 神奈川県川崎市高津区末長1116番地 Kanagawa, (JP)</p> <p>(72) 発明者 ; および (75) 発明者 / 出願人 (米国についてのみ) 小林正幸(KOBAYASHI, Masayuki)[JP/JP] 中島正道(NAKAJIMA, Masamichi)[JP/JP] 傳田勇人(DENDA, Hayato)[JP/JP] 〒213-0013 神奈川県川崎市高津区末長1116番地 株式会社 富士通ゼネラル内 Kanagawa, (JP)</p>	<p>(74) 代理人 弁理士 古澤俊明, 外(FURUSAWA, Toshiaki et al.) 〒102-0093 東京都千代田区平河町1丁目5番3号 大和屋ビル3階 Tokyo, (JP)</p> <p>(81) 指定国 AU, CA, KR, US, 欧州特許 (AT, BE, CH, DE, DK, ES, FI, FR, GB, GR, IE, IT, LU, MC, NL, PT, SE).</p> <p>添付公開書類 国際調査報告書</p>
--	---

(54)Title: MOVING PICTURE CORRECTING CIRCUIT OF DISPLAY

(54)発明の名称 ディスプレイ装置の動画補正回路

(57) Abstract

A moving vector between frame is detected by a moving vector detecting unit and the display positions of the subfields of pixels in a block are corrected using a moving picture correcting unit in accordance with the detection values of the moving vector. The picture quality is not deteriorated when corrected. In order not to output an erroneous moving vector, a lowest correlation factor S1 detected by a lowest correlation factor detecting unit (20) is multiplied by 1.5, the correlation factors not larger than S1 are substituted by S2 ( $S2 \leq S1$ ), and, among a plurality of blocks with the correlation factors S2, the block closest to the origin is used as the starting point of the moving vector. In order not to input an erroneous moving vector to the moving picture correcting unit, a moving vector is determined by the majority decision of the moving vectors of surrounding blocks. The movement of a line has first priority (Fig. 13).

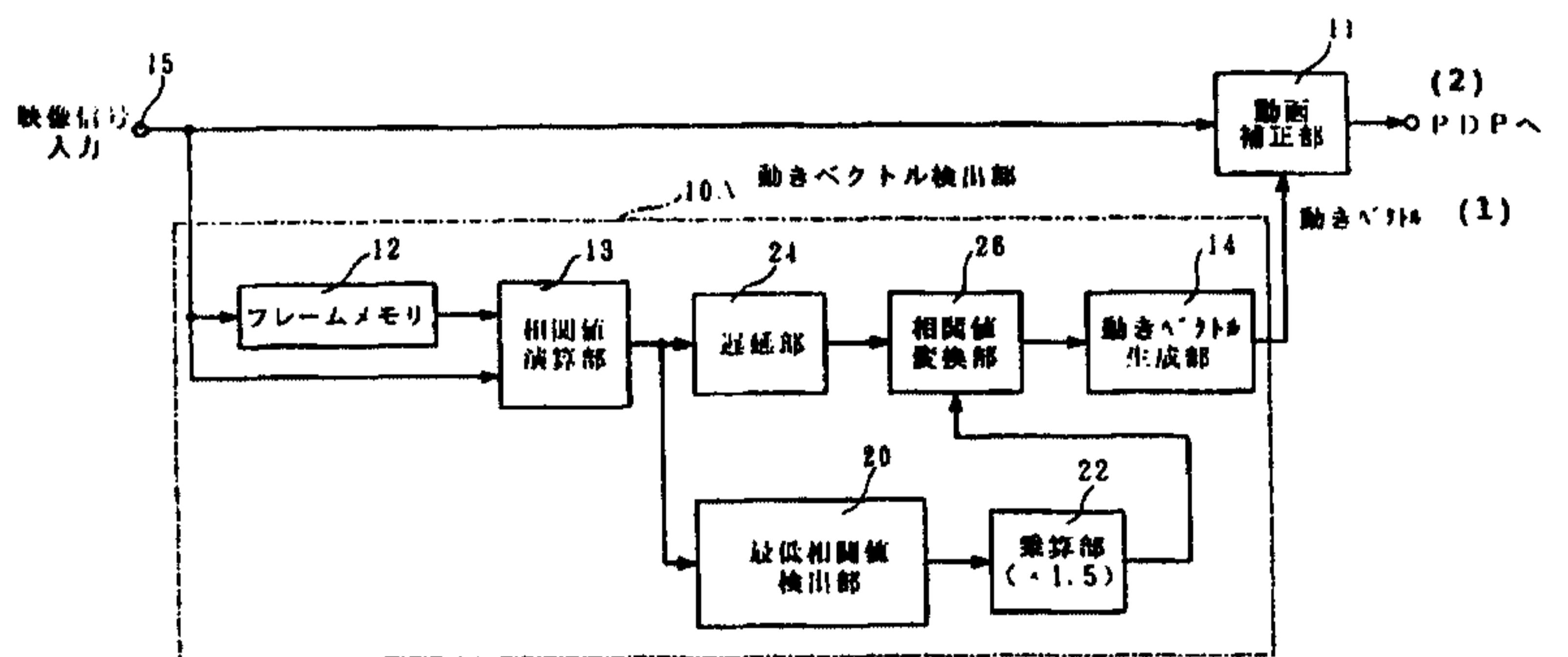

- 10A ... moving vector detecting unit
- 11 ... moving picture correcting unit
- 12 ... frame memory
- 13 ... correlation factor calculating unit
- 14 ... moving vector generating unit
- 15 ... video signal input
- 20 ... lowest correlation factor detecting unit
- 22 ... multiplying unit
- 24 ... delaying unit
- 26 ... correlation factor converting unit
- (1) ... moving vector
- (2) ... to PDP

S P E C I F I C A T I O NMOVING PICTURE CORRECTING CIRCUIT OF DISPLAY5 TECHNICAL FIELD

This invention relates to a moving image correcting circuit of a display device that displays a multitone image by time-sharing one frame into plural subfields (or subframes) and emitting the subfields corresponding to the luminance level of input image  
10 signal.

BACKGROUND TECHNOLOGY

The display devices using PDP (Plasma Display Panel) and LCD (Liquid Crystal Panel) have been attracting public attention as thin,  
15 light-weighted display units. Completely different from the conventional CRT driving method, the drive method of this PDP is a direct drive by digitalized image input signal. The luminance tone as emitted from panel face depends therefore on the number of bits of the signal to be processed.

20 The PDP may roughly be divided into AC and DC type methods whose fundamental characteristics differ from each other. In any AC type PDP, sufficient characteristics have been grasped as far as is concerned its luminance and service life. As for the tonal display, however, 64-tone display was the maximum reported from  
25 trial manufacture level. Recently the future 256-tone method by Address/Display Separation type drive method (ADS subfield method) has been proposed.

Figures 1(a) and (b) show the exemplary drive sequence and drive waveform of the PDP used in this ADS subfield method with 8 bits and 256 tones.

In Figure 1(a), one frame is composed of eight subfields SF1, SF2, SF3, SF4, SF5, SF6, SF7, and SF8 whose relative ratios of luminance are 1, 2, 4, 8, 16, 32, 64, and 128 respectively. Combination of this luminance of eight screens enables a display in 256 tones.

In Figure 1(b), the respective subfields are composed of the address duration that writes one screen of refreshed data and the sustaining duration that defines the luminance level of these subfields. In the address duration, a wall charge is formed initially at each pixel simultaneously over all the screens, and then the sustaining pulses are given to all the screens for display. The brightness of the subfield is proportional to the number of sustaining pulses to be set to the predetermined luminance. Two hundred and fifty-six tones display is thus actualized.

The foregoing display unit of address/display separation type drive method was conventionally provided with such a moving image correcting circuit as shown in Figure 2 in order to reduce the visual display deviation resulting from the display of a moving image. The moving image correcting circuit shown in Figure 2 comprised the moving image correcting portion 11 and the motion vector detecting portion 10, which in turn consisted, as shown in Figure 3, of the frame memory 12, correlation value operation part 13 and motion vector generating portion 14.

In the motion vector detecting portion 10, the respective

components act as follows. Based on the image signal as input into the input terminal 15, the frame memory 12 makes an image signal by one frame before the current frame picture (referred to as "preceding frame picture"). The correlation value operation part 5 13 sequentially seeks after the correlation values (differential values) of the image signal for all the blocks in the detection area of the motion vectors in the preceding frame, referring to the block forming the subject of the current frame picture (the block consisting of a single or plural pixels, 2 X 2 pixels, for example). 10 The motion vector generating portion 14 generates a displacement vector (a signal representing displacement direction and displacement amount) whose starting point and end point are the block position of preceding frame picture where the correlation value is minimal and the origin of motion vector (the block position 15 of the preceding frame picture at a position corresponding to the block of current frame picture) respectively. The motion vector generating portion 14 generates this displacement vector as a motion vector of the block forming the subject.

In the moving image correcting portion 11, the image signal as 20 input into the input terminal 15 was corrected on the basis of the detected value of the motion vector detecting portion 10 (namely, the motion vector). The image signal thus corrected was output to the PDP (not shown) through the intermediary of the output terminal 16. The moving image was thus corrected by correcting 25 the display position of each subfield for the pixels in the subject block.

We will now describe in detail how the correlation value

operation part 13 in the motion vector detecting portion 10 operates the correlation values. For purpose of discussion, we assume here that, as shown in Figures 4(a) and (b), the detection area KR of the motion vector of the preceding frame picture has 25 blocks (5 X 5 blocks) and that the image (pictorial image) that was at the position of the block ZB51 in this detection area KR has now displaced to the position of the block GB33 in the current frame picture. Further, it is assumed that the blocks ZB11 to ZB65 of the preceding frame picture and the blocks GB11 to GB55 of the current frame picture are formed respectively with 2 X 2 pixels (or as many dots).

If the subject block of the current frame picture is GB33, the correlation value operation part 13 will sequentially compute, by the following expression,

$$S = |A1 - A2| + |B1 - B2| + |C1 - C2| + |D1 - D2|$$

the correlation values of image signal for all the blocks ZB11 to ZB55 in the detection area KR of the preceding frame picture referring, as datum, to this block GB33, all along the direction shown by the alternate long and two short dashed line arrow in Figure 4(a).

In the formula, A1, B1, C1, and D1 represent the luminance levels of the pixels forming the respective blocks of preceding frame picture ZB11 to ZB55 as shown in Figure 5(a), while A2, B2, C2, and D2 indicate the luminance levels of the pixels forming the subject block of current frame picture GB33 as shown in Figure 5(b).

The motion vector generating portion 14 compares the plural correlation values as obtained in the correlation value operation part 13 with each other, and generates, as shown by the thick lines

in Figure 4(b), the displacement vector MV whose starting and end points are respectively the position of the block ZB51 of preceding frame picture where the correlation value is minimal and origin of motion vector (block ZB33 position of preceding frame picture. corresponding to the block GB33 in the current frame picture). The motion vector generating portion 14 then outputs this vector MV as the motion picture of the subject block GB33.

The motion vectors can be obtained in a similar fashion also for other blocks (for instance, GB11 or GB55) of the current frame picture, when the motion vector detection area KR of the preceding frame picture embraces 25 peripheral blocks ( $5 \times 5$  blocks) centered around the corresponding origin (for example, positions of the blocks of preceding frame picture ZB11 or ZB55 corresponding to the block GB11 or GB55).

Since, however, the block position corresponding to the least correlation value does not always coincide with the starting point (or end point) of the displacement vector if any dispersion appears in the correlation value as obtained from the correlation value operation part 13 due, for example, to the noise in the input image signal or to the fluctuation of the input image signal, there were some cases where erroneous motion vectors were detected that differed from the intrinsic motion vectors representing the motion as viewed by humans.

For simplicity, we may assume that the detection area KR of preceding frame picture be  $9 \times 9 = 81$  blocks and that the correlation values obtained from the correlation value operation part 13 for the blocks ZB11 to ZB99 in this detection area KR be as those shown

in Figure 6. Let us also assume that a correlation value, out of those in Figure 6, for the block ZB65 near the origin of preceding frame picture (block ZB55 position at vertical vector "0" and horizontal vector "0") changes from intrinsic "0" to "10" and the correlation value for the block ZB82 away from the origin changes from intrinsic "20" to "9" both by reason of noise, fluctuation or the like. Under these conditions, the motion vector generating portion 14 compares the correlation values shown in Figure 6 with each other, and generates and outputs a motion vector whose starting point and end point are respectively the block ZB82 position corresponding to the least correlation value "9" and the origin. Namely, as shown in Figure 6, not the motion vector with horizontal vector "0" and vertical vector 1 with, as the starting point, the block B65 position corresponding to the intrinsic least correlation value "0", but an erroneous motion vector with horizontal vector "-3" and vertical vector "3" with the block B82 as starting point is output.

The conventional art was therefore problematical in that the moving image correction conversely worsens the picture quality if the moving image is corrected by the moving image correcting portion 11 based on the foregoing erroneous motion vector.

Let us take it for granted that, for example as shown in Figures 7(a) and (b), in the nine blocks (3 X 3 blocks) B11 to B33, the detected value of the motion vector of the central block B22 changes from "2" or "3" to "5" due to the influence of noise, fluctuation or the like, and that the detected values of the motion vectors of the 8 peripheral blocks B11 to B33 (except B22) remain "2" or "3"

without being affected by any noise or fluctuation. Then, for any pixels in the eight peripheral blocks B11 to B33 (except B22) the moving image can be corrected on the basis of a correct detected values "2" or "3" while for any pixels in the central block B22 the moving image correction is committed on the basis of erroneously  
5 detected value "5". Thus, the prior art was problematical in that ironically the correction of moving image caused the picture quality to be degraded.

It is also to be assumed that, as shown in Figure 8, there be  
10 no motion vector detected (no motion) for the three blocks B13, B22, and B33 influenced by noise, fluctuation or the like out of the nine (3 x 3 blocks) B11 to B33, and that motion vectors be detected (hatched portions in the figure) for the six remaining blocks B11, B12, B21, B23, B31, and B32 without any influence of noise or  
15 fluctuation. Then, the moving image correction intended for enhancing the picture quality may be performed for the pixels in the six blocks B11, B12, B21, B23, B31, and B32 from which the motion vectors have been detected, but no moving image can be corrected for any pixels in the three blocks B13, B22, and B33 from which no  
20 motion vector has been detected. The result was the same; that is, such a moving image correction was problematical in that it conversely caused the degradation of the picture quality.

This invention, made in the light of the foregoing problematical points, is intended to prevent the picture quality from being  
25 worsened due to the noise in or fluctuation of input image signal if the moving image is corrected to reduce any visual display deviation engendered when displaying the moving image in a display

device that displays multitoneal image by time-sharing one frame into plural subfields and emitting the subfields corresponding to the luminance level of input image signal.

5 DISCLOSURE OF THE INVENTION

The moving image correction circuit by the first invention is characterized in that in a display device that displays multitoneal image by time-sharing one frame into plural subfields and emitting the subfields corresponding to the luminance level of input image  
10 signal, said circuit has a motion vector detecting portion that detects the motion vector in a single frame or inter-frame blocks (for instance,  $2 \times 2$  pixels) on the basis of said input image signal, and the moving image correcting portion that outputs, to said display device, the signal which corrected the display position of  
15 respective subfields for the pixels in the blocks, based on the detected value of said motion vector detecting portion, wherein said motion vector detecting portion has a correlation value operation portion that operates the correlation values of image signal corresponding to all the blocks in the detection area of preceding  
20 frame picture on the basis of the blocks forming the subject of current frame picture, a least correlation value detecting portion that detects the least correlation value  $S_1$  having the highest correlation among the plural correlation values as obtained in said correlation value operation portion, a multiplier that multiplies  
25 this least correlation value  $S_1$  by a coefficient  $k$  ( $k > 1$ ), a correlation value converting portion that converts, the correlation values not more than the multiplied value  $k \times S_1$  from among the plural

correlation values as obtained in the correlation value operation portion, into a set correlation value  $S_2$  ( $S_2 \leq S_1$ ) and outputs this value  $S_2$ , and a motion vector generating portion that detects the correlation value corresponding to the block the nearest to the origin from among the set correlation values  $S_2$  as output from said correlation value converting portion, generates a displacement vector whose starting point and end point are the block position corresponding to said detected correlation value and the origin respectively, and outputs this displacement vector as a motion vector.

For ease of explanation, let us consider a case where the correlation value obtained in the correlation value operation part suffering a dispersion due to noise, fluctuation or the like, the least correlation value  $S_1$  (9 for example) detected from the least correlation value detecting portion is that corresponding to an erroneous block away from the origin, and the intrinsic least correlation value ("0" for example) corresponding to a block near the origin changes into a correlation value  $S_{1a}$  (for example, "10") larger than  $S_1$ . In such a similar, conventional case as shown in Figure 6, an erroneous motion vector is detected whose starting and end points are the block position corresponding to the least correlation value  $S_1$  and the origin respectively. In our case, however, such an erroneous motion vector is kept from being detected by the first invention. That is, the correlation value converting portion converts the correlation value not larger than the multiplied value  $K \times S_1$  ( $1.5 \times S_1$  for example) from among the correlation values obtained in the correlation value operation part,

into a set correlation value S2 not larger than S1 ("0" for example) to include the correlation value S1a before the conversion in the least correlation value (S2) forming the subject of detection.

The motion vector generating portion detects the correlation  
5 value corresponding to the block the nearest to the origin from among plural least correlation values (corresponding to the correlation value S1a before the conversion), and generates a displacement vector whose starting point and end point are the block position corresponding to said detected correlation value and the origin  
10 respectively and outputs this displacement vector as a motion vector. This configuration may prevent the motion vector detecting portion to output an erroneous motion vector due to noise, fluctuation or the like, avoiding thus the degradation of picture quality in the correction of moving image in the moving image correcting portion.

15 The moving image correction circuit by the second invention is characterized in that in a display device that displays multitoneal image by time-sharing one frame into plural subfields and emitting the subfields corresponding to the luminance level of input image signal, said circuit has a motion vector detecting  
20 portion that detects the motion vector in a single frame or inter-frame blocks based on input image signal, a majority processing portion that seeks after the most numerous identical detect values from among the detection values detected by the motion vector detecting portion for all the blocks within the set range  
25 S including the subject block, and a moving image correcting portion that outputs, to said display device, the signal which corrected the display position of respective subfields of the pixels

in the subject block, based on the detected value as obtained in said majority processing portion.

We now consider a case where one frame is time-shared into n number of subfields SFn to SF1 to display multitone image of n bits of input image signal. The motion vector detecting portion  
5 detects the displacement direction (upward on the screen, for example) and displacement amount (5 dots or 5 pixels per frame) of inter-frame blocks (that is, detects the motion vector). The majority processing portion seeks after the most numerous,  
10 identical detect values from among the detected values by the motion vector detecting portion for the blocks within the set range S. The moving image correcting portion corrects the input image signal based on the detected value as obtained in the majority processing portion and outputs this signal as corrected to the display device.  
15 This configuration allows the majority processing to eliminate uneven motion vector even if the motion vector detecting portion outputs any erroneous motion vector due to noise, fluctuation or the like, thereby keeping the picture quality from being degraded in the moving image correcting process.

20 The moving image correction circuit by the third invention is characterized in that in a display device that displays multitone image by time-sharing one frame into plural subfields and emitting the subfields corresponding to the luminance level of input image signal, said circuit has a motion vector detecting portion that  
25 detects the motion vector in a single frame or inter-frame blocks on the basis of input image signal, a majority processing portion that seeks after the most numerous identical detect values from

among the values detected by the motion vector detecting portion  
for all the blocks within the set range S including the subject block,  
a vertical/horizontal/oblique detecting portion that detects  
whether or not the blocks having identical detect values by the  
5 motion vector detecting portion have been continuously arranged  
vertically, horizontally or obliquely within the set range S  
including the subject block and outputs the identical detect values  
when detecting, a selector that selects the detected values as  
output from this vertical/horizontal/oblique detecting portion if  
10 there is any detection output therefrom and selects the detect  
values obtained in the majority processing portion if there is no  
such detection output, and a moving image correcting portion that  
outputs, to said display device, the signal which corrected the  
display position of respective subfields of the pixels in the  
15 subject block, based on the detected value as selected by this  
selector.

As is the case with the foregoing second invention, this  
configuration, namely the third invention allows the majority  
processing to eliminate uneven motion vector even if the motion  
20 vector detecting portion outputs any erroneous motion vector due  
to noise, fluctuation or the like, thereby keeping the picture  
quality from being degraded in the moving image correcting process.  
Since further this third invention is so designed that, when an image  
with one respective vertical, horizontal and oblique lines moves  
25 toward predetermined direction, the detected values of this image  
with vertical, horizontal and oblique lines are made to supersede,  
by means of the detection output of the vertical/horizontal/oblique

detecting portion, the detection values obtained by majority processing, an exact moving image correction can be performed deep in detail into the image.

The moving image correction circuit by the fourth invention is characterized in that in a display device that displays multitoneal image by time-sharing one frame into plural subfields and emitting the subfields corresponding to the luminance level of input image signal, said circuit has a motion vector detecting portion that detects the motion vector in a single frame or inter-frame blocks on the basis of input image signal, a motion vector delaying portion that seeks after the motion vector of each block in the set range S consisting of the subject block and peripheral blocks by delaying the detection value of said motion vector detecting portion, a motion vector counting portion that counts up the number of the blocks detected as having motion vectors in all the blocks within the set range S, a count comparing portion that compares if the count by said motion vector counting portion is superior to the set value or not, a motion vector embedding portion that outputs the motion vector based on the output from the motion vector delaying portion and that of the count comparing portion, and a moving image correcting portion that outputs to the display device the signal which corrected the display position of each subfield of pixels within the subject block on the basis of the motion vector as output from said motion vector embedding portion, wherein said motion vector embedding portion outputs, as the motion vector of the subject block, the blocks of the motion vectors detected as having motion vectors within the set range S, when there is no motion vector

of subject block as obtained in the motion vector delaying portion and that the count comparing portion is sending out a comparison signal, and otherwise outputs the motion vector of subject block as obtained in the motion vector delaying portion.

5       When there is no motion vector of subject block as obtained from the motion vector delaying portion and the count comparing portion is sending out a comparison signal, the motion vector embedding portion outputs, as the motion vector, and to moving correcting portion the motion vector of the blocks detected as having the motion  
10       vector in the set range S. That is, when the number of the blocks detected as having motion vector in the set range S is superior to the set value, the motion vector of the subject block is embedded (substituted) with the motion vector of the blocks detected as having motion vector even if there is no motion vector of subject block.  
15       This makes it possible that the display position of each subfield may be corrected for the pixels in the subject block on the basis of the motion vector as embedded by the motion vector embedding portion, even if the motion vector has not been detected by reason of noise, fluctuation or the like despite the very existence of the  
20       motion vector.       The dispersion in the subject block and peripheral blocks being thus annihilated, the moving image can be corrected without deteriorating the picture quality.

      The moving image correcting portion by the 5th, 6th and 7th inventions replacing the motion vector detecting portion, one of  
25       the components of the foregoing 2nd, 3rd, and 4th inventions, with the motion vector detecting portion, one of the components by the first invention, it is prevented that any erroneous motion vector

be output from the upstream motion vector detecting portion. At the same time the downstream circuit keeps any erroneous motion vector from entering the moving image correcting portion even when an erroneous motion vector may come out of the motion vector  
5 detecting portion. This configuration makes it possible to keep, with higher precision, the picture quality from being degraded in the correction of moving image by the moving image correcting portion.

10 BRIEF DESCRIPTION OF THE DRAWINGS

Figure 1 diagrammatically illustrates the address/display separation type drive method, in which (a) is an explanatory diagram of 256-tone drive sequence, and (b) shows some drive waveforms.

Figure 2 is a block diagram showing the moving image correcting  
15 circuit for a display device in a conventional embodiment.

Figure 3 is another block diagram that shows the motion vector detecting portion in Figure 2.

Figure 4 describes the action of Figure 3, wherein (a) is a schematic diagram of a preceding frame picture, and (b) shows the  
20 current frame picture.

Figure 5 depicts an exemplary configuration of blocks intended to illustrate how to compute the correlation values, wherein (a) is a diagram showing that the luminance levels of respective pixels constituting the blocks (2 X 2 pixels) of the preceding frame picture  
25 are A1, B1, C1, and D1, while (b) shows that the luminance levels of respective pixels constituting the blocks (2 X 2 pixels) of the current frame picture are A2, B2, C2, and D2.

Figure 6 is an exemplary illustration of the correlation value data when there arises some dispersion due to noise, fluctuation or the like in the correlation values as obtained from the correlation value operation part.

5 Figure 7 is an explanatory diagram showing a case where the detected value of motion vector of the subject block B22 becomes by large different from those of peripheral blocks B11 to B33 (except B22) because of noise, fluctuation or the like, wherein (a) gives a case where the blocks with "2" as detected value are the most  
10 numerous among the blocks B11 to B33 within the set range S, and (b) is an explanatory diagram showing a case where the number of blocks with "2" and that with "3" as detected values are the greatest and identical with each other among the blocks B11 to B33 within the set range S.

15 Figure 8 is an explanatory illustration showing a case where noise, fluctuation or the like prevented to detect the motion vector of the subject block (motion vector  $MV22 = 0$ ) among the nine blocks B11 to B33 in the moving image portion.

Figure 9 is a block diagram showing an embodiment of the moving  
20 image correcting circuit by the first invention.

Figure 10 depicts the correlation value data before and after the conversion at the correlation value data converting portion, wherein (a) illustrates the correlation value data 1 before the conversion, and (b) the correlation value data 2 after the  
25 conversion.

Figure 11 is a block diagram showing an embodiment of the moving image correcting circuit by the second invention.

Figure 12 illustrates an exemplary detect value of the motion vector of the blocks within the set range S when an image of vertical, horizontal, and oblique lines, each one line, displaces toward predetermined direction, wherein (a) illustrates the detect values  
5 in the case of vertical line image, (b) those of horizontal line image, (c) those of left-to-right descending oblique line image, and (d) those of left-to-right ascending oblique line image.

Figure 13 is a block diagram showing an embodiment of a moving image correcting circuit by the third invention.

10 Figure 14 illustrates yet another exemplary detect value of the motion vector of the blocks within the set range S when an image of vertical, horizontal, and oblique lines, each one line, displaces toward predetermined direction, wherein (a) illustrates the detect values in the case of vertical line image, (b) those of horizontal  
15 line image, (c) those of left-to-right descending oblique line image, and (d) those of left-to-right ascending oblique line image.

Figure 15 is a block diagram showing an embodiment of the fourth invention.

Figure 16 is another block diagram that shows the motion vector  
20 delaying portion in Figure 15.

Figure 17 shows the blocks with and without motion vectors within the set range S ( $3 \times 3$  blocks), in which (a) illustrates a case where the number K of blocks with motion vector is equal to or more than the set value Q (=5) (case of embedding), and (b) a  
25 case where the number K of blocks with motion vector is less than the set value Q (=5) (case without embedding).

Figure 18 is a block diagram showing an embodiment of the moving

image correcting circuit by the fifth invention.

Figure 19 is a block diagram showing an embodiment of the moving image correcting circuit by the sixth invention.

Figure 20 is a block diagram showing an embodiment of the moving  
5 image correcting circuit by the seventh invention.

BEST EMBODIMENT TO CARRY OUT THE INVENTION

Referring now more particularly to the attached drawings, this invention will be described more in detail.

10 Figure 9 shows an embodiment of the moving image correcting circuit by the first invention, wherein like reference characters designate like or corresponding parts in Figures 2 and 3. In Figure 9, 10A represents the motion vector detecting portion, 11 is the moving image correcting portion, and said motion vector detecting  
15 portion 10A comprises the frame memory 12, the correlation value operation part 13, the least correlation value detecting portion 20, the multiplier 22, the delaying portion 24, the correlation value converting portion 26, and the motion vector generating portion 14.

20 Said frame memory 12 delays by one frame the image signal as input into the input terminal 15 to generate the image signal of the preceding frame picture, which is output to the correlation value operation part 13.

Said correlation value operation part 13 sequentially seeks  
25 after and outputs the correlation values (differential values) with all the blocks (for example, ZB11 to ZB55 In Figure 4(a)) within the detection area KR of the motion vector in the preceding frame

picture referring to the block GB forming the subject of the current frame picture (for example, GB33 in Figure 4 (b)).

Said least correlation value detecting portion 20 detects the least correlation value S1 with highest correlation from among the plural correlation values obtained at said correlation value operation part 13, and outputs the least correlation value S1 thus obtained.

Said multiplier 22 multiplies, by a preset coefficient 1.5 (case where the coefficient K is 1.5), the least correlation value S1 as detected in said least correlation value detecting portion 20, and outputs the product  $1.5 \times S1$ .

Said delaying portion 24 delays the correlation value obtained in said correlation value operation part 13 by the time required for the signal processing of said least correlation value detecting portion 20 and multiplier 22.

Said correlation value converting portion 26 converts, into set correlation value "0" (zero, case of set correlation value  $S2 = 0$ ), the correlation value not more than the product  $1.5 \times S1$  from among the correlation values obtained in said correlation value operation part 13 and delayed by predetermined time in said delaying portion 24.

Said motion vector generating portion 14 compares the correlation values output from said correlation value converting portion 26 with each other, detects the correlation value corresponding to the block nearest to the origin (for example, ZB33 position in Figure 4 (a)) from among the plural set correlation values "0", generates a displacement vector whose starting point

and end point are the block position corresponding to said detected correlation value and the origin, respectively, and outputs this vector to the output terminal 16 as the motion vector of the block to be detected of the current frame picture.

5        Said moving image correcting portion 11 corrects the image signal as input into said input terminal 15 on the basis of the motion vector as detected in said motion vector detecting portion 10A, and outputs this image signal to the PDP side through the intermediary of the output terminal 16.

10        Now we will describe the action of Figure 9 referring concomitantly to Figure 10.

For descriptive purpose, we hereby assume that the detection area KR of the preceding frame be 81 blocks centered on the origin (position of block ZB55 of preceding frame corresponding to block  
15 GB55 forming the subject of detection of the current frame) as was the case shown in Figure 6. It is also assumed that the correlation values as obtained in the correlation value operation part 13 for the blocks ZB11 to ZB99 in the detection area KR have changed into the correlation value data 1 (same value as in Figure 6) as shown  
20 in Figure 10(a) due to noise, fluctuation or the like. Namely, we suppose that the correlation value corresponding to the block ZB65 near the origin of the preceding frame picture (position of block ZB55) from among the correlation value data 1 has changed from its intrinsic "0" into "10" and the correlation value corresponding  
25 to the block ZB82 away from the origin has changed from its intrinsic "20" into the least "9", and that no correlation values corresponding to any other blocks have changed.

(1) The least correlation value detecting portion 20 detects the least correlation value "9" ( $S_1 = 9$ ) with the highest correlation from among the correlation value data 1 as obtained in the correlation value operation part 13, while the multiplier 22 multiplies, by a coefficient 1.5 ( $K = 1.5$ ), the least correlation value "9", and outputs the product "13.5" ( $k \times S_1 = 13.5$ ).

(2) The correlation value converting portion 26 converts into set correlation value "0" (case of  $S_2 = 0$ ) the correlation value not greater than the product "13.5" from among the correlation value data 1 as obtained in the correlation value operation part 13 and delayed, by the predetermined time, in the delaying portion 24, and then outputs the correlation value data 2 as shown in Figure 10(b). That is, the correlation value converting portion 26 converts into the set correlation value "0", the correlation values "12", "10", "12", "12" and "9" corresponding to the blocks ZB64, ZB65, ZB66, ZB75 and ZB82 whose correlation values are not greater than the product "13.5" to widen the range forming the subject of detection.

(3) The motion vector generating portion 14 compares the respective correlation values of the correlation value data 2 output from said correlation value converting portion 26 with each other, detects the correlation value corresponding to the block ZB65 nearest to the origin from among the plural set correlation values "0" (correlation values corresponding to the blocks ZB64, ZB65, ZB66, ZB75, and ZB82), generates a displacement vector whose starting point and end point are the position of the block ZB65 nearest to said detected correlation value and the origin, respectively, and outputs this vector to the output terminal 16 as a motion vector.

That is, it outputs to the output terminal 16 a correct motion vector with horizontal vector "0" and vertical vector "1".

This configuration allows therefore to prevent any output of erroneous motion vector from the motion vector detecting portion  
5 10A due to noise, fluctuation or the like, avoiding thereby the degradation of the picture quality by the moving image correction at the moving image correcting portion.

Although we have described the foregoing embodiment assuming that the set correlation value S2 converted by the correlation  
10 values converting portion be "0", this invention is not limited to such an embodiment. The set correlation value S2 may be any value if only it is less than the least correlation value S1 as detected in the least correlation value detecting portion ("5" for example).

Although the foregoing embodiment has been described assuming  
15 a case where the coefficient K by which the multiplier multiplies the least correlation value S1 ("9" for example) be 1.5, this invention is not limited to any such embodiment. The coefficient may be any value if only it is greater than 1 so that the intrinsic  
20 least correlation value (for example, correlation value "10") should fall within the range forming the subject of the detection of motion vector despite the dispersion in correlation value due to noise, fluctuation or the like.

Though, in the foregoing embodiment, the correlation value operation part is so designed as calculates out the correlation  
25 value taking the plural peripheral blocks ( $9 \times 9 = 81$  blocks for example) centered on the block of preceding frame picture (ZB55 for example) at the position corresponding to the block forming the

subject of detection (GB55 for example) as the detection area KR of motion vector, this invention is not limited to such an embodiment. For instance, the detection area KR of motion vector may be a certain area ( $5 \times 5 = 25$  blocks, for example) centered on the corresponding block ZB33 of preceding frame picture (block corresponding to GB33) as shown in Figure 4(a), or some area ( $5 \times 5 = 25$  blocks, for example) including the corresponding block of the preceding frame picture at any position other than the center.

Figure 11 shows an embodiment of the moving image correcting circuit by the second invention, wherein like reference characters designate like or corresponding parts as in Figure 2. In Figure 11, the numeral 10 represents a motion vector detecting portion, 11 a moving image correcting portion, and 30 a majority processing portion.

Said majority processing portion 30 seeks after and outputs the most numerous, identical detection values from among the detect values by said motion vector detecting portion 10 for the blocks in the set range S including the subject block. As shown in Figure 7(a), for instance, if the detected value of the subject block B22 is "5", the detected value of peripheral blocks B11, B12, B21, B31, and B32 is "2" and the detected value of B13, B23, and B33 is "3", then the blocks of detected value "2" is the most numerous (5). So this detected value "2" is determined as such and output by the majority processing portion 30.

Based on the detected value ("2" for example) output from said majority processing portion 30, said moving image correcting portion 11 corrects the display positions of the respective

subfields (SF<sub>n</sub> to SF<sub>1</sub>) of the pixels in the subject block B22 as input into said input terminal 15, and outputs the correction signal to the PDP through the intermediary of the output terminal 16.

Now we will describe the action of Figure 11 referring  
5 concomitantly to Figure 7(a).

For purpose of discussion, it is presupposed as shown in Figure 7(a) that the set range S embraces nine blocks including the block B22, the subject of processing and its peripheral blocks B11 to B33 (except B22) and that a part of the detection values of the motion  
10 vector detecting portion 10 has been changed from the intrinsic value into differing one due to noise, fluctuation or the like. We assume, namely, that the detected value of the motion vector of the subject block B22 has changed from its intrinsic value ("2" for  
example) into "5" and that the peripheral blocks B11 to B33 (except  
15 B22) have not been subjected to the influence of any noise nor fluctuation. Note that the detected values "5", "2", and "3" as shown in Figure 7(a) represent the displacement amount (5, 2, and  
3 dots/frame, for example) in certain direction (upward for example). From this it results that the detected values "-5", "-2" and "-  
20 3" (not shown) represent the displacement amount (5, 2, and 3 dots/frame, for example) in opposite direction.

(1) The majority processing portion 30 seeks after the most numerous, identical detection value "2" from among the detection values "5", "2" and "3" by the motion vector detecting portion 10  
25 for the blocks B11 to B33 within the set range S including the subject block B22.

(2) The moving image correcting portion 11 outputs, to the

PDP through the intermediary of the output terminal 16, the signal that has corrected the display positions of the subfields SF<sub>n</sub> to SF 1 (n in number) of the pixels within the subject block B22, based on the detection value "2" as obtained in the majority processing  
5 portion 30.

Thus, even if the detected value of the subject block B22 becomes a value ("5") away from the detected values ("2", "3") of the peripheral blocks B11 to B33 due to noise, fluctuation or the like, the majority processing may eliminate the protruded value ("5"),  
10 preventing thereby the degradation of the picture quality in the moving image correction.

In the foregoing embodiment, the majority processing portion has been so designed that the most numerous, identical detection values ("2" in the case of Figure 7(a)) are searched for from among  
15 the detected values by the motion vector detecting portion for the blocks within the set range S, but this invention may not be limited to such a configuration. This invention is also applicable to any cases where the blocks in the set range S are ranked, and when there are numerous, identical detection values as determined by  
20 majority processing method, the detection value of higher rank may be sought after from among these plural, identical detection values.

Let us presume, for instance, that the first rank be given to the subject block B22, and the second to ninth ranks assigned to the peripheral blocks B11 to B33 (except B22) in the sequential order  
25 of B11, B12, B13, B21, B23, B31, B32, and B33. The majority processing portion under these ranking conditions seeks after and outputs the most numerous, identical detection value "2" when the

detected values of motion vector are as shown in Figure 7(a), as was in the case of the preceding embodiment. If, however, as shown in Figure 7(b), the detected value of the blocks B11, B12, B13 and B23 is "3", the detected value of the blocks B21, B31, B32 and B33 is "2" and both block number is 4 (not to be determined by majority processing method), it searches for and outputs the detection value "3" of the block B11 of the highest rank. It goes without saying that the above ranking is for the referential purpose only, and that this invention may not be limited to such a ranking.

10 The foregoing embodiment has been so designed as to prevent the degradation of picture quality of the moving image in the moving image correction by eliminating any protruded value through the majority processing (including the cases with and without ranking). However, we have such exceptional cases where the majority processing is not enough to solve the problem.

15 In such a case where a certain amount (3 dots/frame for example) of an image with a vertical line is displacing toward predetermined direction (horizontal, for example), the detected value of the motion vector detecting portion 10 becomes "3" both for the subject block and the peripheral blocks B12, and B32, and "0" for any other peripheral blocks B11, B13, B21, B23, B31, and B33, as shown in Figure 12(a).

20 The majority processing therefore resulted in the output of "0", the most numerous detection value, and this was problematical in that 25 the moving image correcting portion 11 thus considered that there was no motion of the subject block B22. In such a case where an image with one horizontal line or one with an oblique line is

displacing toward predetermined direction (3 dots/frame, for example), the detected values of the motion vector detecting portion 10 become as shown in Figure 12(b), (c) and (d), which is similarly problematical.

5 Figure 13 shows an embodiment of the moving image correcting portion by the third invention, contrived to solve the problems such as above. Like reference characters designate like or corresponding parts as in Figure 11.

10 In Figure 13, the numeral 32 represents a vertical/horizontal/oblique detecting portion and 34 a selector.

Said vertical/horizontal/oblique detecting portion 32 determines if the blocks with identical detected values by the motion vector detecting portion 10 have been continuously arranged either vertically, horizontally or obliquely including the subject  
15 block B22 within the set range S, and outputs, when detecting, said identical detected values (for example, the detected value of the subject block B22).

When there exists a detected output "se" (H level, for example) of said vertical/horizontal/oblique detecting portion 32, said  
20 selectors 34 selects the detection value "sv" (motion vector) as output by this vertical/horizontal/oblique detecting portion 32, and if the same "se" does not exist (L level for example), it selects the detected value "tv" (motion vector) as obtained from the majority processing portion 30.

25 When, for that reason, the detected value by the motion vector detecting portion 10 corresponds to the vertical line image, which is a particular value "N" (N = 3 for example) for the subject block

B22 and peripheral blocks B12 and B32, and an indefinite value "X" (X = 0 or 1, for example) other than N for any other peripheral blocks B11, B13, B21, B23, B31 and B33, the selector 34 selects the detected value "N" (sv = N) through the detected output "se" of the vertical/  
5 horizontal/oblique detecting portion 32, and the moving image correcting portion 11 outputs to the PDP through the intermediary of the output terminal 16 the signal that corrected the display positions of the subfields SFn to SF1 (n in number) for the pixels in the subject block B22 based on the detected value "N" chosen at  
10 the selector 34.

The action is similar to the foregoing case of vertical line image, when the detected values by the motion vector detecting portion 10 correspond, as shown in Figure 14(b), (c), and (d) respectively, to the image of horizontal line, left-to-right  
15 descending line and left-to-right ascending line.

When, on the other hand, the detected values by the motion vector detecting portion 10 differ from those shown in Figures 14(a), (b), (c), and (d) (for example, they do not correspond to the image of vertical, horizontal, and oblique lines), there is no detection  
20 output "se" of the vertical/horizontal/oblique detecting portion 32 (L level for example). Therefore, the selector 34 will output the detected value "tv" as output by the majority processing portion 30, while the moving image correcting portion 11 corrects the display positions of subfields SFn to SF1 (n in number) for the pixels  
25 in the subject block B22, based on the detection value "tv" chosen at the selector 34.

In the foregoing embodiment, we described a case of the range

within which the majority processing portion makes decision by majority, the range forming the subject of the vertical/horizontal/oblique detecting portion, that is, the case where the set range S embraces  $3 \times 3 = 9$  blocks. This invention however is not to be understood as so limited. The embodiment is also available for such a case where the set range S is  $5 \times 5 = 25$  blocks.

Figure 15 illustrates an embodiment of the moving image correcting circuit by the fourth invention, in which like reference characters designate the like or corresponding parts as in Figure 2. In Figure 15, the numeral 10 represents the motion vector detecting portion, 11 the moving image correcting portion, 40 the motion vector delaying portion, 42 the motion vector counting portion, 44 the count comparing portion, and 46 the motion vector embedding portion.

Said motion vector delaying portion 40 delays the detected value of said motion vector detecting portion 10 to output the motion vector of respective blocks in the set range S ( $3 \times 3 = 9$  blocks, for example) composed of the subject block and peripheral blocks.

Said motion vector delaying portion 40 combines, as shown in Figure 16, six 1-dot delaying element D to D and two 1-line delaying element LM and LM. Based on the motion vector as input, this delaying portion 40 outputs the motion vectors of respective blocks within the set range S ( $3 \times 3 = 9$  blocks), including the subject block B22 and its peripheral blocks B11 to B33 (except B22) as shown in Figures 17 (a) and (b). The 1-dot delaying element D comprises D-FF (Flip-Flop), while 1-line delaying element LM comprises line memory.

Based on the motion vector output from said motion vector delaying portion 40, said motion vector counting portion 42 counts up the number of the blocks detected as having motion vectors in all the blocks B11 to B33 within the set range S to output this count  
5 K.

Said count comparing portion 44 compares the count K by said motion vector counting portion 42 with the set value Q as input into the set value input terminal 48, and outputs a comparison signal (H-level signal, for example) if  $K \geq Q$ .

10 Said motion vector embedding portion 46 outputs, as the motion vector of the subject block, the motion vector of the block with higher priority from among the blocks detected as having motion vector within the set range S, when said count comparing portion 44 outputs a comparison signal (H-level signal for example) and  
15 there is no motion vector of the subject block B22 to be output from said motion vector delaying portion 40 (namely, when the motion vector detecting portion 10 detects no motion vector for the subject block B22), and outputs the motion vector of the subject block B22 to be output from said motion vector delaying portion 40 in any other  
20 cases than the above. If, for instance, the set range S embraces the nine blocks as shown in Figure 17(a) and that the blocks detected as having the motion vector are B11, B12, B21, B23, B31, and B32 (case of  $K \geq Q$ ) as hatched in the same drawing, the blocks B11 to B33 (except B22) other than the subject block B22 are ranked  
25 beforehand (for example, into a sequential order of: B21, B23, B12, B32, B11, B13, B31, and B33) and the motion vector of subject block with higher rank (block B21 for example) from among the blocks

detected as having motion vector B11, B12, B21, B23, B31, and B32 is output as the motion vector of the subject block B22.

Said moving image correcting portion 11 outputs to the PDP through the output terminal 16 the signal that corrected the display position of the subfields SF<sub>n</sub> to SF<sub>1</sub> (n in number) of each frame of pixels in the subject block, based on the motion vector as output from said motion vector embedding portion 46. In the case as shown in Fig. 17(a), for instance, the signal that corrected the display positions of the subfields SF<sub>n</sub> to SF<sub>1</sub> (n in number) of each frame of pixels in the subject block B22 is output to the PDP through the output terminal 16, based on the motion vector (the motion vector of block B21 for example) as output from said motion vector embedding portion 46.

We will now describe the action of Figure 15 concomitantly referring to Figures 16 and 17.

For purpose of discussion, we herein assume, as shown in Figure 17(a) and (b), that the set range S embraces nine blocks consisting of the subject block B22 to be processed and of its peripheral blocks B11 to B33 (except B22) and priority is given beforehand to these peripheral blocks in the sequential order of B21, B23, B12, B32, B11, B13, B31, and B33, and that the set value Q of the count comparing portion 44 is 5.

(1) Based on the n-bit image signal as input into the input terminal 15, the motion vector detecting portion 10 detects the motion vector (displacement direction and displacement amount) of in single frame or inter-frame blocks, and the motion vector delaying portion 40 outputs the motion vectors MV11 to MV33 of

respective blocks B11 to B33 in the set range S based on the motion vector as output from the motion vector detecting portion 10. Based in turn on the motion vector output from the motion vector delaying portion 40, the motion vector counting portion 42 counts up the number of the blocks detected as having the motion vector out of all the blocks B11 to B33 within the set range S to output the count K.

If, as shown in Figure 17(a), there are six blocks detected as having motion vector (shown as hatched) out of all the nine blocks within the set range S, the count K to be output from the motion vector counting portion 42 is 6 ( $K = 6$ ). If the number of the blocks detected as having motion vector is 4 instead as shown in Figure 17(b), the count K to be output from the motion vector counting portion 42 will be four ( $K = 4$ ).

(2) When, as shown in Fig. 17(a), there is no motion vector of the subject block B22 ( $MN22 = 0$ ) and  $K = 6$ , it becomes that  $K \geq Q$  ( $Q = 5$ ). Therefore, the count comparing portion 44 outputs the comparison signal (H-level signal, for example). Hence, the motion vector embedding portion 46 outputs, as the motion vector of the subject block B22, the motion vector MV21 of the block B21 having higher priority from among the blocks detected as having motion vector in the set range S. That is, the motion vector MV22 ( $= 0$ ) of the subject block B22 is embedded by the motion vector MV21 of the block B21.

(3) Based on the motion vector MV21 embedded by the motion vector embedding portion 46, the moving image correcting portion 11 outputs to the PDP through the output terminal 16 the signal that

corrected the display positions of the subfields SF<sub>n</sub> to SF<sub>1</sub> (n in number) of the pixels in the subject block B22. Therefore, even when the motion vector of the subject block B22 intrinsically to be detected by the motion vector detecting portion 10 cannot be detected because of noise, fluctuation or the like, the display position may be corrected of the subfields SF<sub>n</sub> to SF<sub>1</sub> (n in number) for the pixels in the subject block B22, based on the motion vector MV21 as embedded at the motion vector embedding portion 46.

(4) When, as shown in Fig. 17(b), there is no motion vector of the subject block (MV22 = 0) and  $K = 4$ , it becomes that  $K < Q$  ( $Q = 5$ ). Therefore, the count comparing portion 44 does not output the comparison signal (L-level signal is output, for example). Hence, the motion vector embedding portion 46 outputs the motion vector MV22 (= 0), as such, namely as the motion vector of the subject block B22. That is to say, the motion vector MV22 (= 0) of subject block B22 cannot be embedded by the motion vector of the peripheral blocks. Therefore, the moving image correcting portion 11 does not correct the display position of the subfields SF<sub>n</sub> to SF<sub>1</sub> for the pixels in the subject block B22.

(5) If there exists the motion vector of the subject block B22 (case of MV22 ≠ 0), the motion vector embedding portion 46 outputs the motion vector MV22 as the motion vector of the subject block B22. That is, if MV22 ≠ 0, the motion vector of the subject block B22 is not embedded by the motion vector of the peripheral blocks whether the count comparing portion 44 outputs the comparison signal or not. Hence, based on this motion vector MV22 (≠ 0), the moving image correcting portion 11 outputs to the PDP through the output

terminal 16 the signal that corrected the display positions of the subfields SF<sub>n</sub> to SF<sub>1</sub> (n in number) of the pixels in the subject block B22.

In the foregoing embodiment, the peripheral blocks in the set range S are arranged beforehand by priority, adopting the motion vector (MV<sub>21</sub> for example) of the blocks with higher priority order from among the blocks detected as having motion vector in the set range S, as a motion vector to be embedded, when there is no motion vector of the subject block B22 (MV<sub>22</sub> = 0) and that the motion vector is to be embedded by the motion vector embedding portion. However, this invention may not be understood as to be limited to this sort of embodiment.

For instance, we may embed no motion vector of the subject block B22 (MV<sub>22</sub> = 0) by the mean value of the motion vectors of the blocks detected as having motion vector in the set range S. In the case of Figure 17(a), more materially, the following formula (1):

$$MV_m = (MV_{11} + MV_{12} + MV_{21} + MV_{23} + MV_{31} + MV_{32})/6 \dots (1)$$

will allow to have the mean value MV<sub>m</sub> of the motion vectors MV<sub>11</sub>, MV<sub>12</sub>, MV<sub>21</sub>, MV<sub>23</sub>, MV<sub>31</sub>, and MV<sub>32</sub> of the blocks B<sub>11</sub>, B<sub>12</sub>, B<sub>21</sub>, B<sub>23</sub>, B<sub>31</sub>, and B<sub>32</sub> detected as having motion vectors in the set range S to embed, by this mean value MV<sub>m</sub>, the no motion vector of the subject block (MV<sub>22</sub> = 0).

Though in the foregoing embodiment the description has been given assuming that the set value Q of the count comparing portion be 5, this invention may not be limited to such an embodiment.

Furthermore, in the foregoing embodiment, the description was made assuming a case where the set range S comprises the subject

block and its eight peripheral blocks (9 in all). But the invention should not be limited to such an embodiment; similar embodiment will be available also for other cases where the set range S comprises  $n \times m$  blocks ( $5 \times 5$  blocks for example).

5        Figure 18 shows an embodiment of the moving image correcting circuit by the fifth invention, wherein the motion vector detecting portion 10 in the embodiment by the second invention, shown in Figure 11 is replaced by the motion vector detecting portion 10A in the embodiment by the first invention.

10        Figure 19 shows an embodiment of the moving image correcting circuit by the sixth invention, wherein the motion vector detecting portion 10 in the embodiment by the third invention, shown in Figure 13 is replaced by the motion vector detecting portion 10A in the embodiment by the first invention.

15        Figure 20 shows an embodiment of the moving image correcting circuit by the seventh invention, wherein the motion vector detecting portion 10 in the embodiment by the fourth invention, shown in Figure 15 is replaced by the motion vector detecting portion 10A in the embodiment by the first invention.

20        The moving image correcting circuit as shown in Figures 18, 19, and 20 keeps any erroneous motion vector from being output from the upstream motion vector detecting portion 10A in such a fashion that no erroneous motion vector should enter the moving image correcting portion in the downstream circuit, even if this motion vector  
25        detecting portion 10A outputs any erroneous vector. The circuit thus may avoid, with yet a higher accuracy, the degradation of picture quality at the time of the correction of the moving image.

In the foregoing embodiment, the description has been made supposing a case where a display device utilizes the PDP. This invention, which should not be limited to such an embodiment, may also be applicable to a digital display unit (for instance, a display  
5 using a LCD panel).

#### INDUSTRIAL AVAILABILITY

In a display device (for example, a display using PDP or LCD panel) that displays multitone image by time-sharing one frame into  
10 plural subfields and emitting the subfields corresponding to the luminance level of input image signal, this invention may be used to protect the picture quality from degrading due to the noise in and fluctuation of the input image signal when correcting the moving image.

C L A I M S

1. A moving image correcting circuit in a display device that displays multitoneal image by time-sharing one frame into plural subfields and emitting the subfields corresponding to the luminance level of input image signal, characterized in that said display unit is provided with a motion vector detecting portion that detects the motion vector of single frame or inter-frame blocks based on said input image signal and with a moving image correcting portion that outputs to said display unit the signal that corrected the display positions of respective subfields for the pixels in said blocks on a basis of the detected value from said motion vector detecting portion, said motion vector detecting portion having a correlation value operation part that computes the correlation value of the image signal corresponding to all the blocks in the detection area of preceding frame picture, a least correlation value detecting portion that detects the least correlation value  $S_1$  endowed with the highest correlation from among plural correlation values as obtained in this correlation value operation part, a multiplier that multiplies this least correlation value  $S_1$  by a coefficient  $K$  ( $K > 1$ ), a correlation value converting portion that replaces the plural correlation values obtained in said correlation value operation part that are not greater than the product  $k \times S_1$  with the set correlation value  $S_2$  ( $S_2 \leq S_1$ ) to output the value thus replaced, a motion vector generating portion that detects a correlation value corresponding to the block nearest to the origin from among the set correlation value  $S_2$  to be output from said

correlation value converting portion, generates a displacement vector whose starting and end points are the position of the block corresponding to said detected correlation value and the origin respectively, and outputs this displacement vector as a motion  
5 vector.

2. The moving image correcting circuit for display as claimed in Claim 1, wherein the correlation value operating part computes correlation value of image signal taking the plural peripheral  
10 blocks centered on the origin as the detection area of the preceding frame picture.

3. The moving image correcting circuit for display as claimed in Claim 1 or 2, wherein the multiplier multiplies the least  
15 correlation value S1 as detected in the least correlation detecting portion by 1.5 (case where the coefficient k is 1.5).

4. A moving image correcting circuit in a display device that displays multitoneal image by time-sharing one frame into plural  
20 subfields and emitting the subfields corresponding to the luminance level of input image signal, characterized in that said moving image correcting circuit has a motion vector detecting portion that detects the motion vectors of single-frame or inter-frame blocks on the basis of said input image signal, a majority processing  
25 portion that obtains the most numerous, identical detection values from among the detected values by said motion vector detecting portion for all the blocks in the set range S including the subject

block, and the moving image correcting portion that outputs to said display unit the signal that corrected the display positions of respective subfields for the pixels in said subject block, on the basis of the detected values as obtained in said majority processing  
5 portion.

5. A moving image correcting circuit in a display device that displays multitoneal image by time-sharing one frame into plural subfields and emitting the subfields corresponding to the luminance level of input image signal, characterized in that said moving image  
10 correcting circuit has a motion vector detecting portion that detects the motion vectors of single-frame or inter-frame blocks on the basis of said input image signal, a majority processing portion that obtains the most numerous, identical detection values from among the detected values by said motion vector detecting  
15 portion for the blocks in the set range S including the subject embodiment, a vertical/horizontal/oblique detecting portion that detects whether or not the blocks detected, by said motion vector detecting portion, as having identical detection values have been arranged continuously either vertically, horizontally or obliquely  
20 including said subject block within said set range S and outputs said identical detected values when detecting, a selector that chooses the detected value output by said vertical/horizontal/oblique detecting portion if there is a detection output of this vertical/horizontal/oblique detecting portion and selects the  
25 detected value as obtained in said majority processing portion if there is no detection output from said vertical /horizontal/oblique detecting portion, and the moving image correcting portion that

outputs to said display unit the signal that corrected the display positions of respective subfields for the pixels in said subject block, on the basis of the detected value as selected by this selector.

5

6. The moving image correcting circuit for display unit as claimed in Claim 4 or 5, wherein the majority processing portion ranks the blocks in the set range S, and if there are plural detected values as obtained by majority, seeks after any detected value of blocks  
10 with higher rank from among these plural detected values.

7. A moving image correcting circuit in a display device that displays multitoneal image by time-sharing one frame into plural subfields and emitting the subfields corresponding to the luminance  
15 level of input image signal, characterized in that said moving image correcting circuit is provided with a motion vector detecting portion that detects the motion vector of single frame or inter-frame blocks based on said input image signal, a motion vector  
20 delaying portion that obtains the motion vectors of respective blocks in the set range S composed of the subject block and its peripheral blocks by delaying the detected values of said motion vector detecting portion, a motion vector counting portion that counts up the number of blocks detected as having motion vectors in any and all the blocks within the set range S, a count comparing  
25 portion that compares if the count of this motion vector counting portion is greater than the set value or not, a motion vector embedding portion that outputs the motion vector corresponding to

the output of said count comparing portion and said motion vector delaying portion, and a moving image correcting portion that outputs to said display unit the signal that corrected the display positions of respective subfields for the pixels in the subject block, on the basis of the motion vectors as output from said motion vector embedding portion, wherein said motion vector embedding portion outputs, as the motion vector of subject block, the motion vectors of the blocks detected as having motion vectors in the set range S when there is no motion vector of subject block as obtained in said motion vector delaying portion and when said count comparing portion outputs a comparison signal, and outputs the motion vector of the subject block as obtained in said motion vector delaying portion in any other cases than the above.

8. The moving image correcting circuit for display unit as claimed in Claim 7, wherein the peripheral blocks in the set range S are ranked beforehand, the motion vector embedding portion outputs, as the motion vector of said subject block, the motion vector of the blocks with higher rank among the blocks detected as having the motion vector in the set range S when the count comparing portion outputs a comparison signal and when the motion vector detecting portion detects no motion vector of said subject block.

9. The moving image correcting circuit for display unit as claimed in Claim 7, wherein the motion vector embedding portion outputs, as the motion vector of the subject block, the mean value of the motion vectors of said blocks detected as having motion vectors in

the set range S when the count comparing portion outputs a comparison signal and the motion vector detecting portion detects inexistence of the motion vector of said subject block.

5 10. The moving image correcting circuit for display unit as claimed in Claim 4, 5, 7, 8 or 9, wherein the motion vector detecting portion has a correlation value operation part that computes the correlation value of image signal for all the blocks in the detection area of the preceding frame picture referring, as a datum, to the subject  
10 block of the current frame picture, a least correlation value detecting portion that detects the least correlation value S1 with the highest correlation from among the plural correlation values as obtained in said correlation value operation part, a multiplier that multiplies this least correlation value S1 by a coefficient  
15 k ( $K > 1$ ), a correlation value converting portion that converts, into the set correlation value S2 ( $S2 \leq S1$ ) the correlation value not greater than the product  $K \times S1$  among the plural correlation values as obtained in said correlation value operation part to output the value thus converted, and finally a motion vector  
20 generating portion that detects the correlation value corresponding to the block nearest to the origin among the set correlation values S2 output from this correlation value converting portion and generates a displacement vector whose starting point and end point are the position of the block corresponding to this detected  
25 correlation value and the origin respectively, to output said displacement vector as a motion vector.

11. The moving image correcting circuit for display unit as claimed  
in Claim 6, wherein the motion vector detecting portion has a  
correlation value operation part that computes the correlation  
value of image signal for all the blocks in the detection area of  
5 the preceding frame picture referring, as a datum, to the subject  
block of the current frame picture, a least correlation value  
detecting portion that detects the least correlation value S1 with  
the highest correlation from among the plural correlation values  
as obtained in said correlation value operation part, a multiplier  
10 that multiplies this least correlation value S1 by a coefficient  
k ( $K > 1$ ), a correlation value converting portion that converts,  
into the set correlation value S2 ( $S2 \leq S1$ ) the correlation value  
not greater than the product  $K \times S1$  among the plural correlation  
values as obtained in said correlation value operation part to  
15 output the value thus converted, and finally a motion vector  
generating portion that detects the correlation value corresponding  
to the block nearest to the origin among the set correlation values  
S2 output from this correlation value converting portion and  
generates a displacement vector whose starting point and end point  
20 are the position of the block corresponding to this detected  
correlation value and the origin respectively, to output said  
displacement vector as a motion vector.

Fig. 1

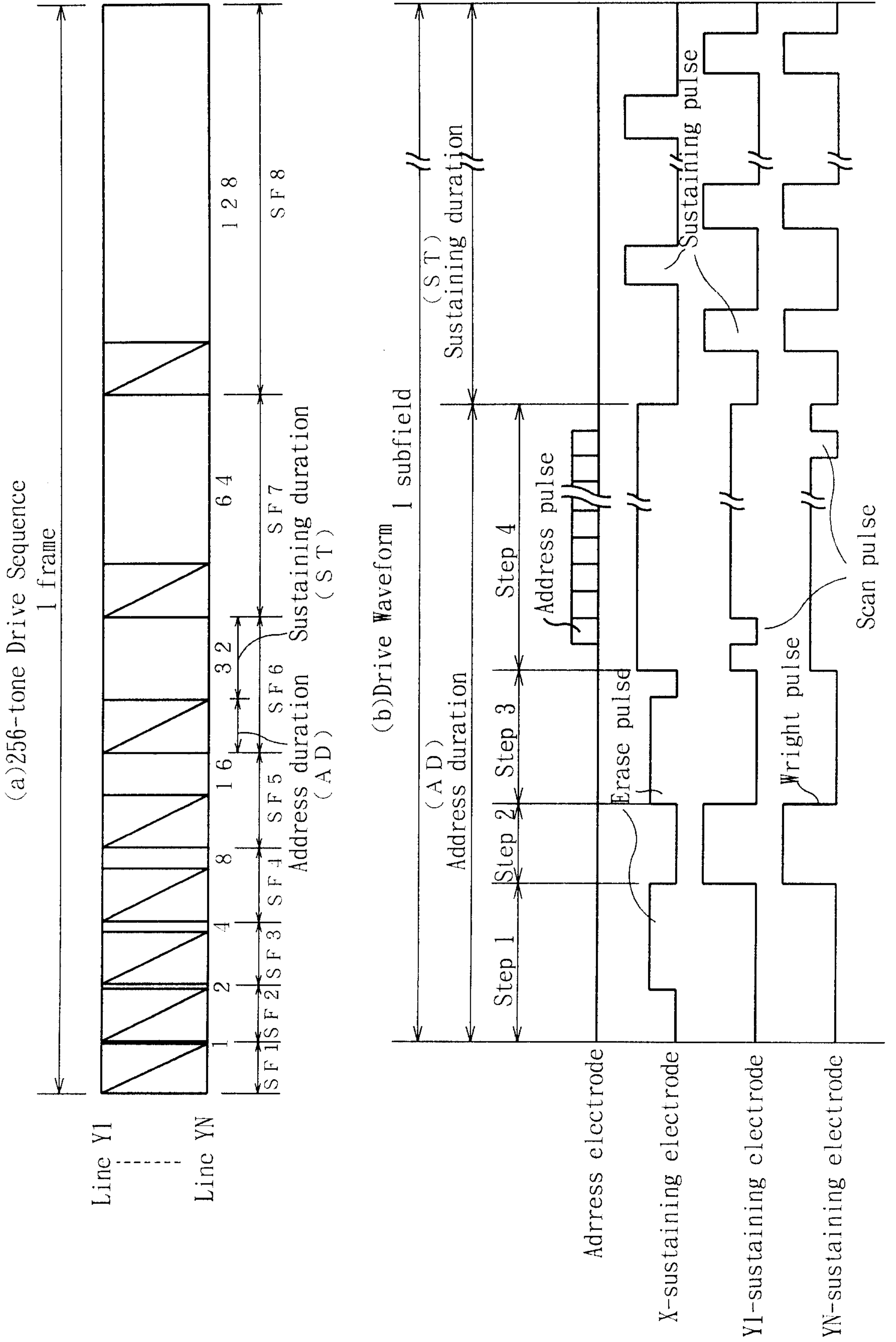

Fig. 2

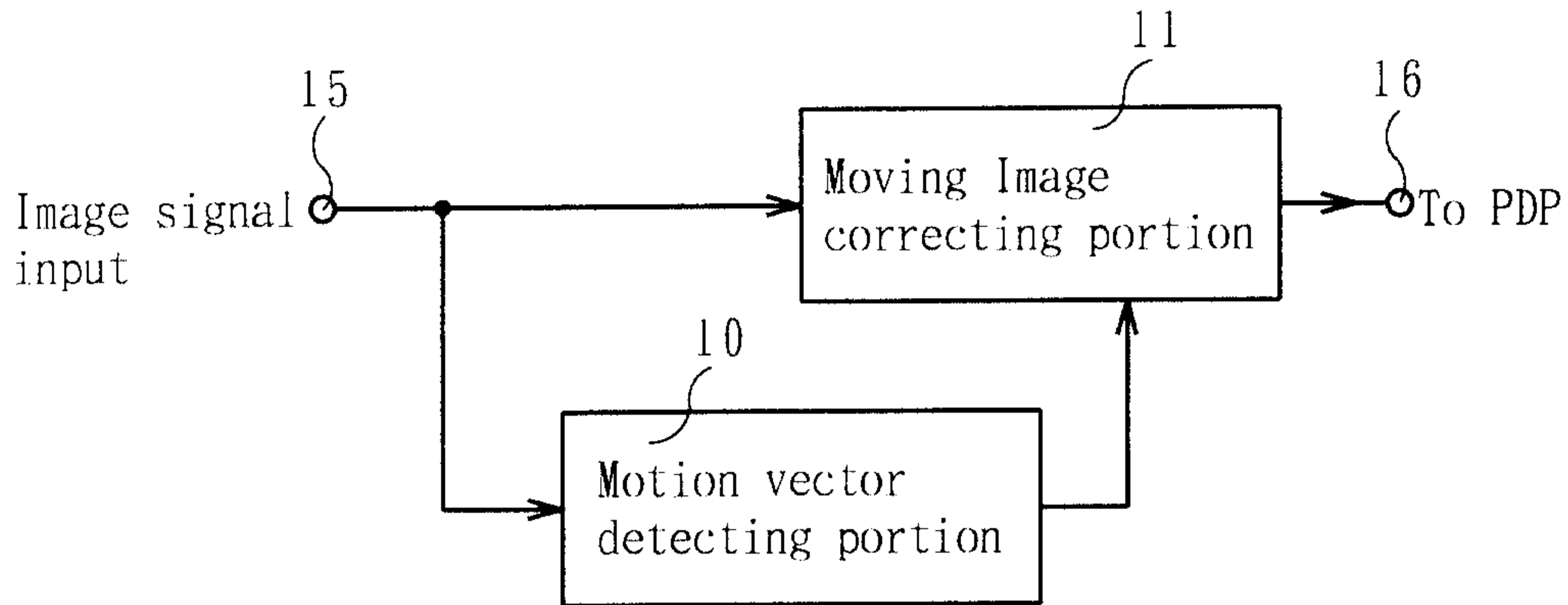

Fig. 3

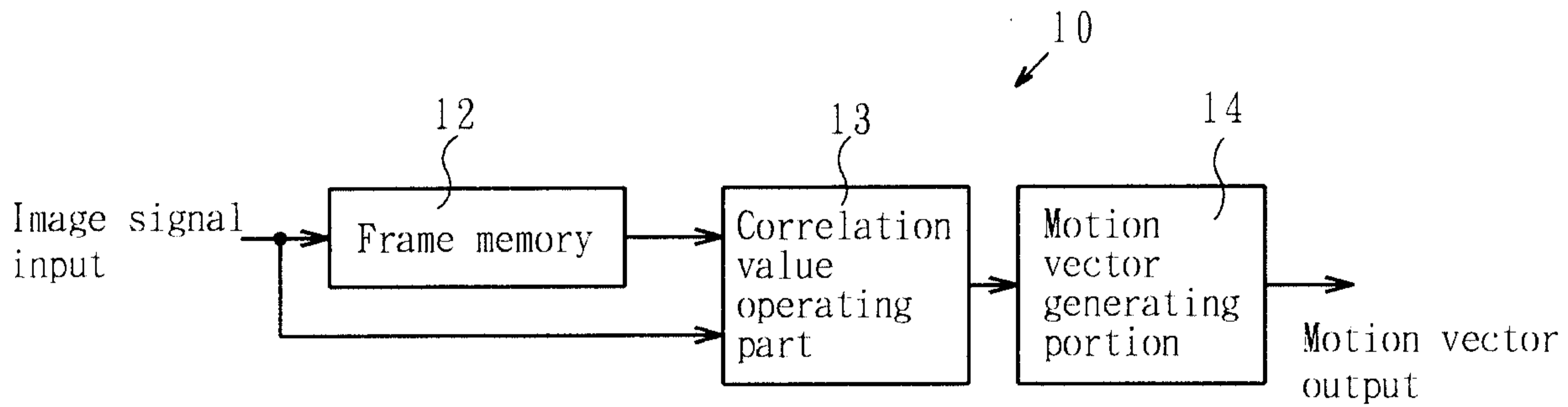
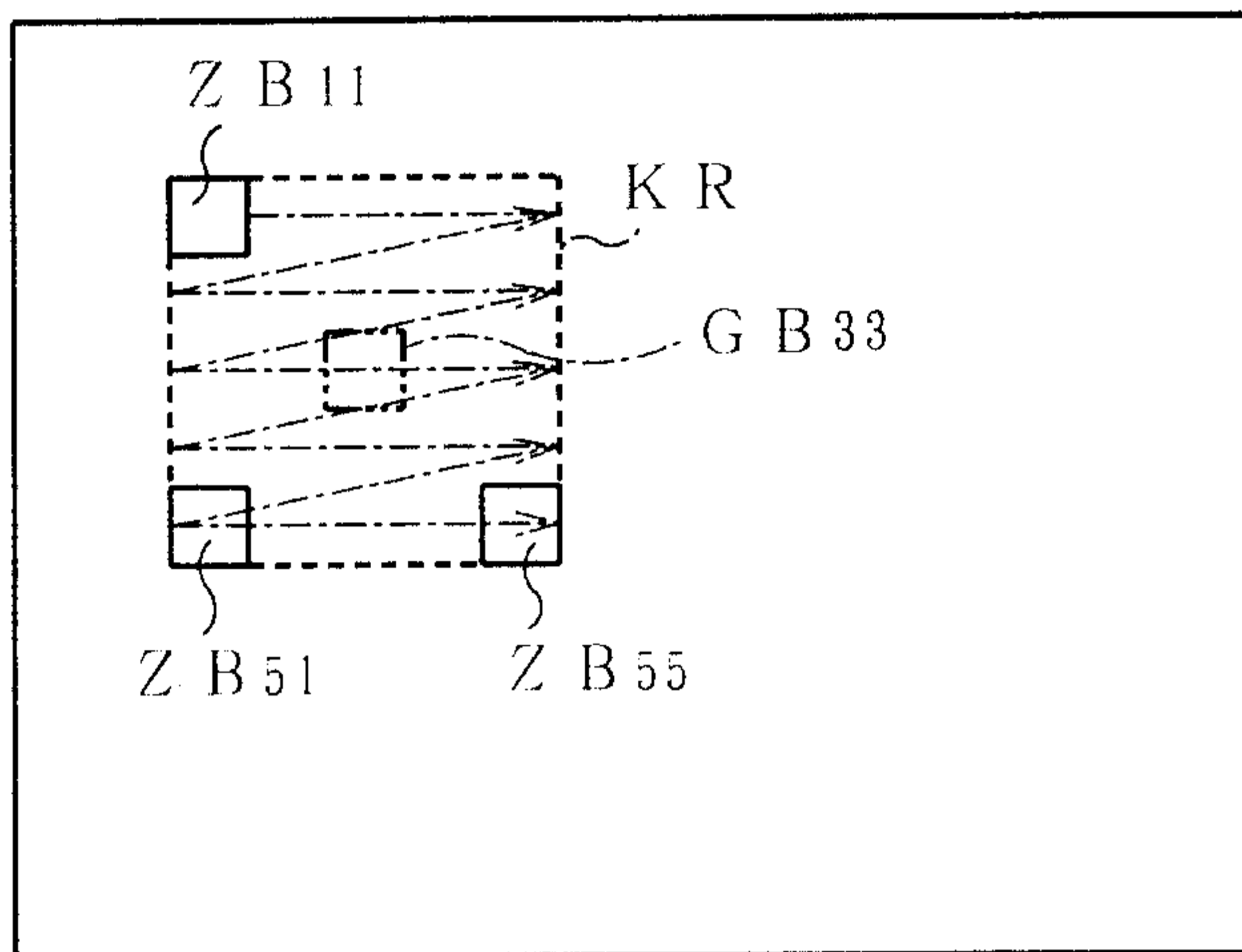

Fig. 4

(a) Preceding frame picture



(b) Current frame picture

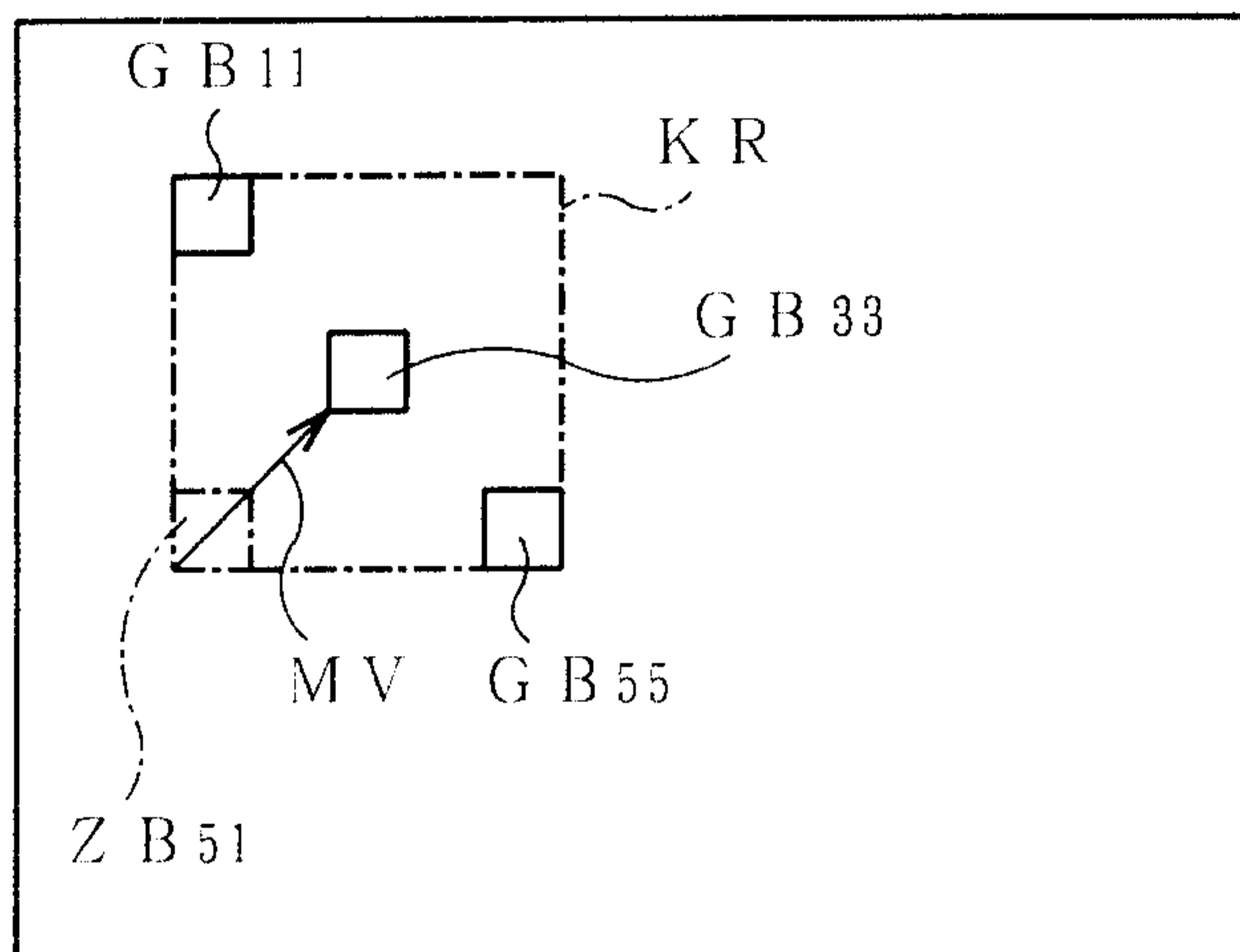

Fig. 5

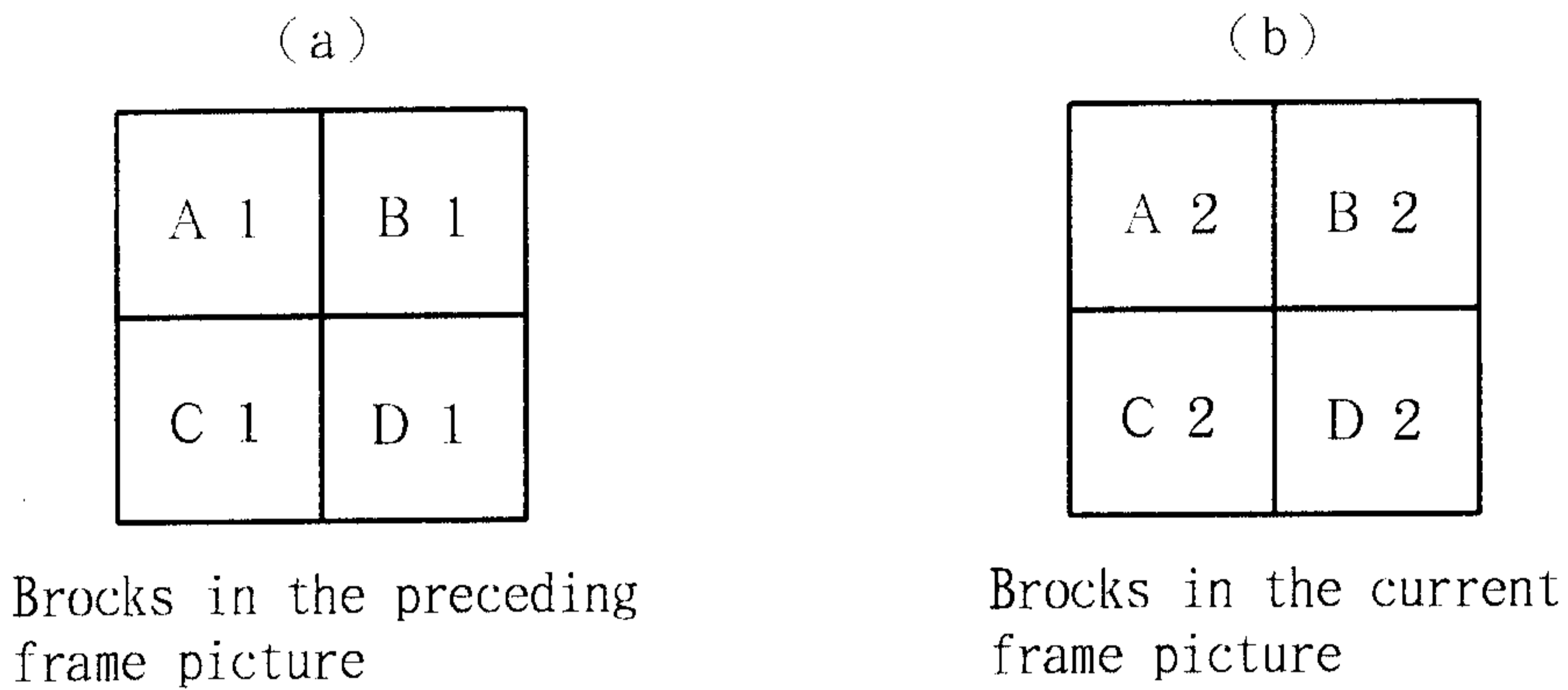

Fig. 6

Vertical vector		Z B 55								
		- 4	- 3	- 2	- 1	0	1	2	3	4
Horizontal vector	- 4	100	100	100	100	100	100	100	100	100
	- 3	100	100	100	100	100	100	100	100	100
	- 2	100	100	100	100	100	100	100	100	100
	- 1	100	100	100	100	100	100	50	100	100
	0	100	100	100	50	20	20	50	100	100
1	100	100	20	12	10	12	100	100	100	
2	100	100	100	20	12	50	100	100	100	
3	100	9	100	100	100	100	100	100	100	
4	100	100	100	100	100	100	100	100	100	
		Z B 82				Z B 65				

5 / 1 3

Fig. 7

(a)

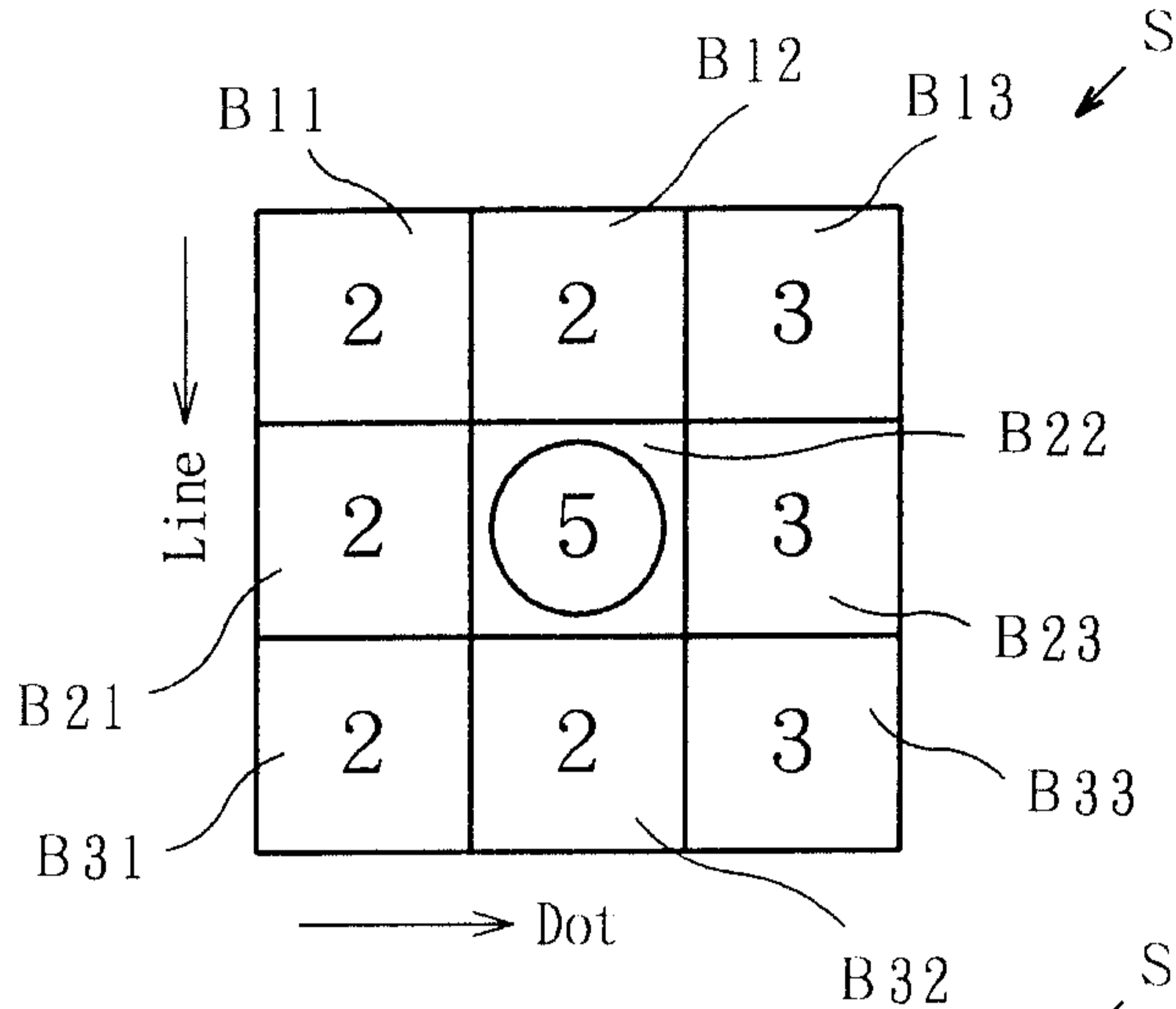

(b)

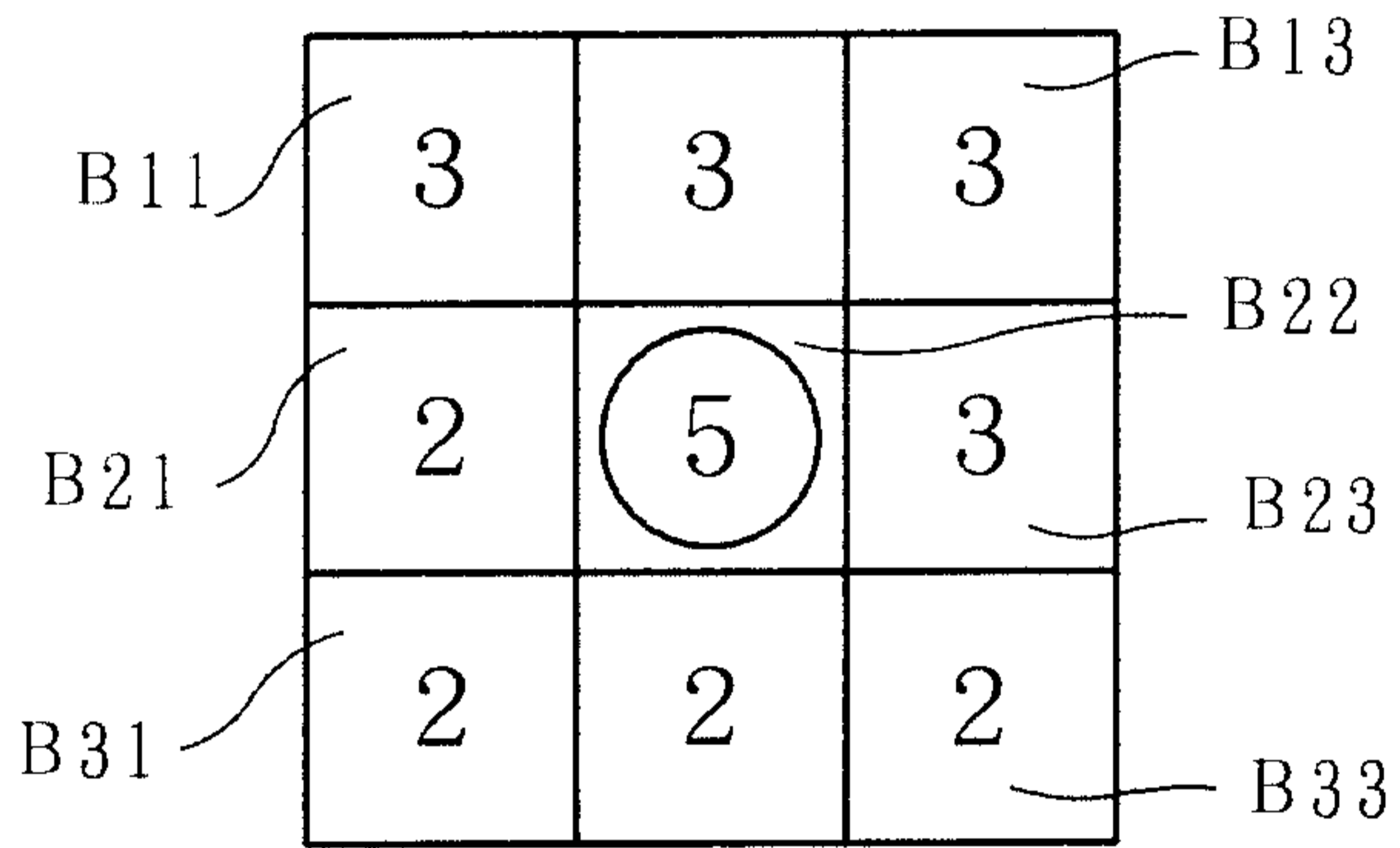

Fig. 8

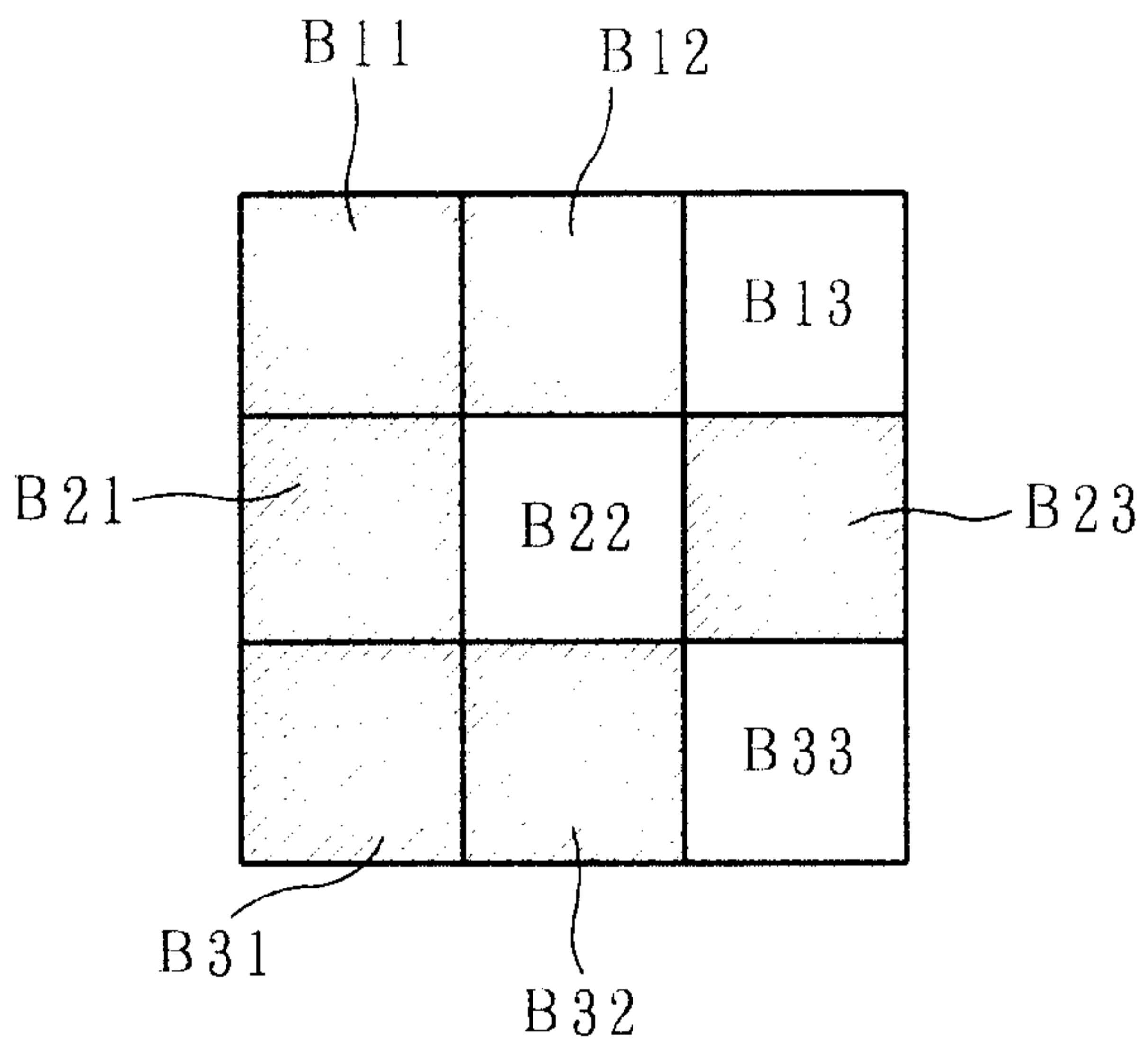

Fig. 9

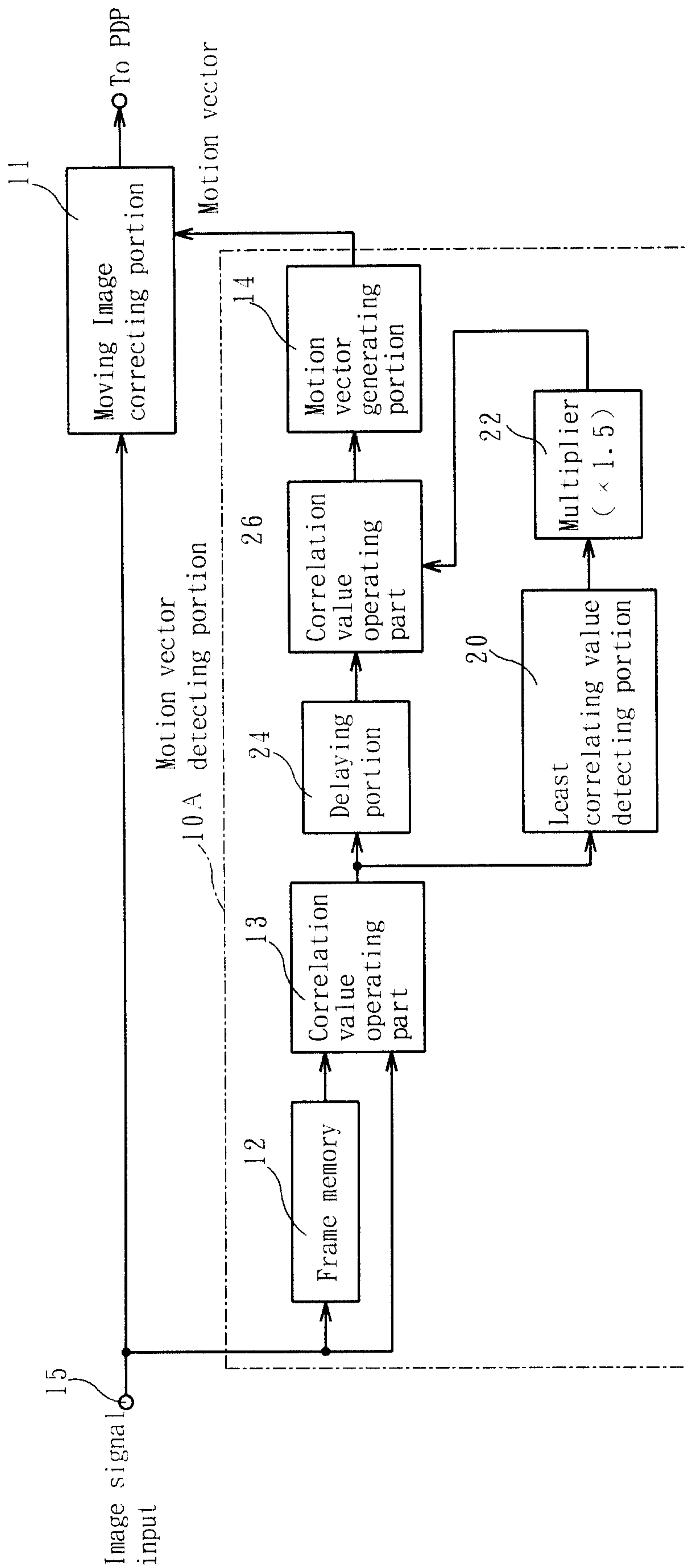

Fig. 10

( a ) Correlation value data1

Vertical vector		Z B55					Z B66			
		- 4	- 3	- 2	- 1	0	1	2	3	4
Horizontal vector	- 4	100	100	100	100	100	100	100	100	100
	- 3	100	100	100	100	100	100	100	100	100
	- 2	100	100	100	100	100	100	100	100	100
	- 1	100	100	100	100	100	100	50	100	100
	0	100	100	100	50	20	20	50	100	100
	1	100	100	20	12	10	12	100	100	100
	2	100	100	100	20	12	50	100	100	100
	3	100	9	100	100	100	100	100	100	100
	4	100	100	100	100	100	100	100	100	100

Z B82
Z B64
Z B75
Z B65

( b ) Correlation value data2

Vertical vector		Z B55					Z B66			
		- 4	- 3	- 2	- 1	0	1	2	3	4
Horizontal vector	- 4	100	100	100	100	100	100	100	100	100
	- 3	100	100	100	100	100	100	100	100	100
	- 2	100	100	100	100	100	100	100	100	100
	- 1	100	100	100	100	100	100	50	100	100
	0	100	100	100	50	20	20	50	100	100
	1	100	100	20	0	0	0	100	100	100
	2	100	100	100	20	0	50	100	100	100
	3	100	0	100	100	100	100	100	100	100
	4	100	100	100	100	100	100	100	100	100

Z B82
Z B64
Z B75
Z B65

Fig. 11

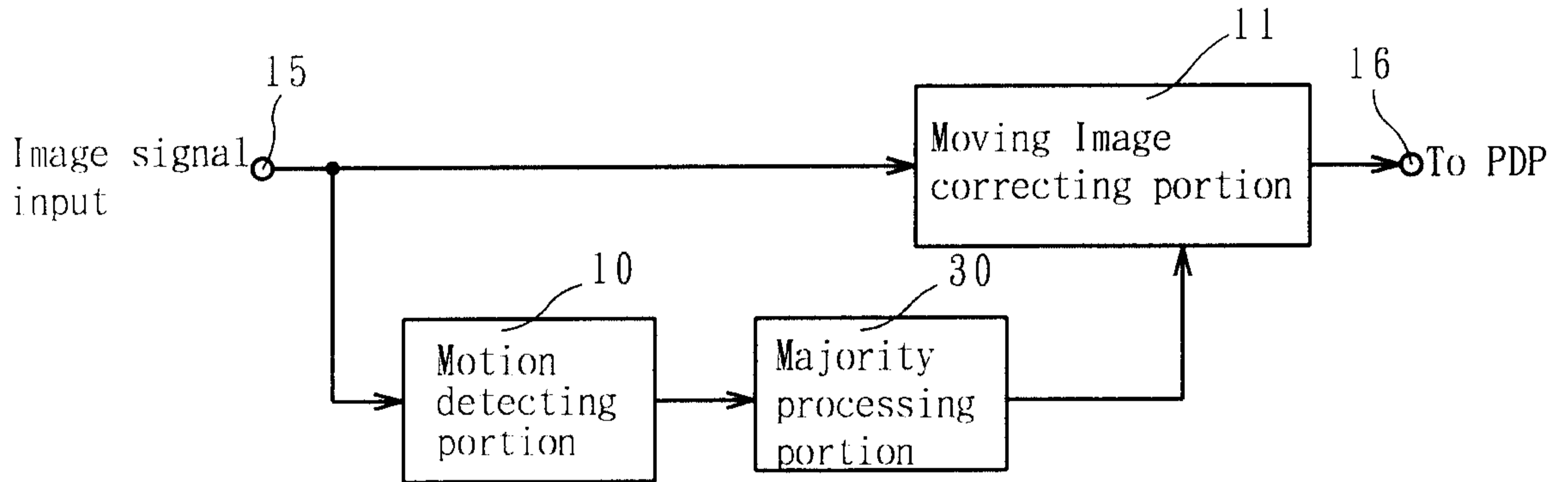

Fig. 12

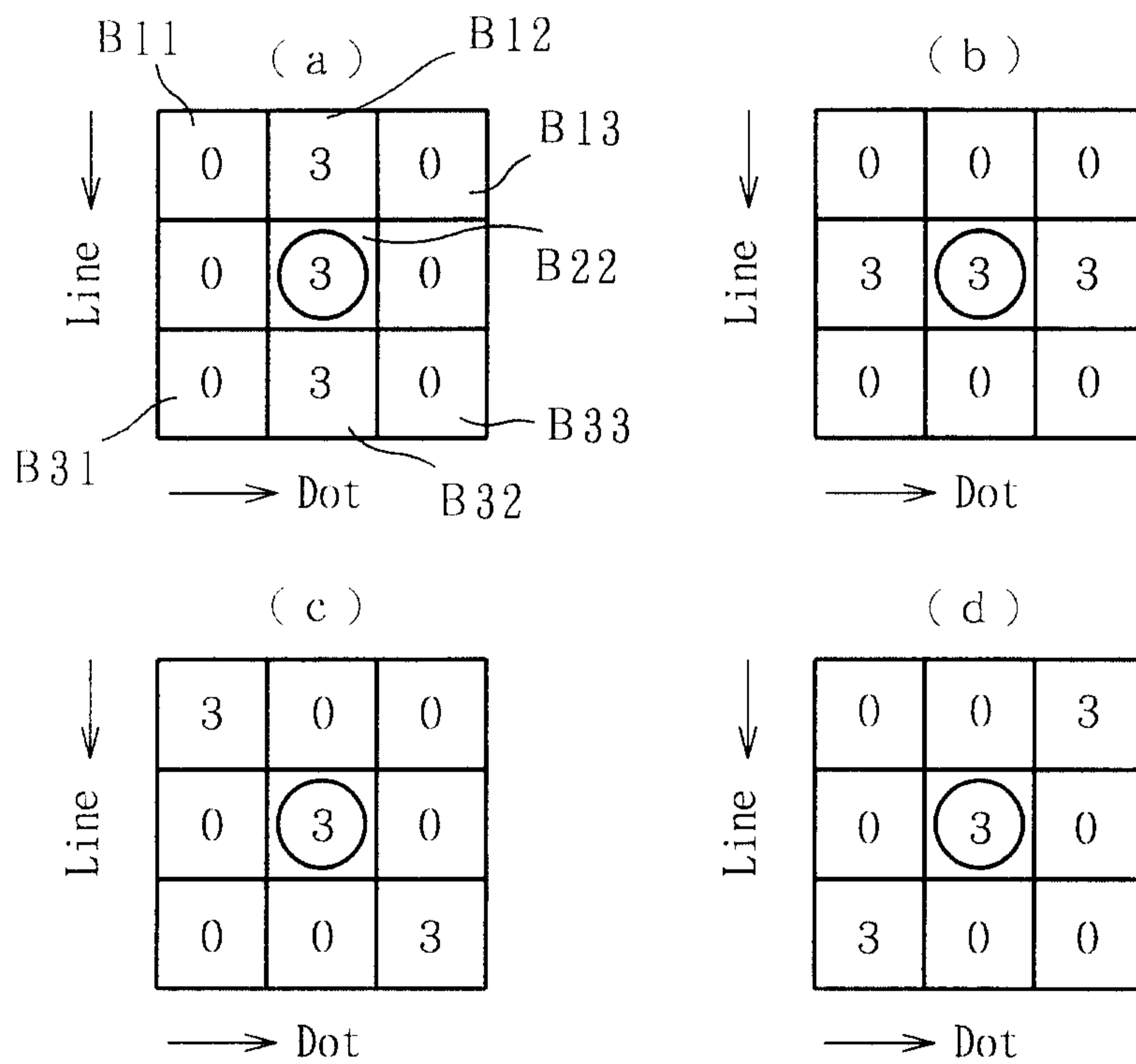

Fig. 13

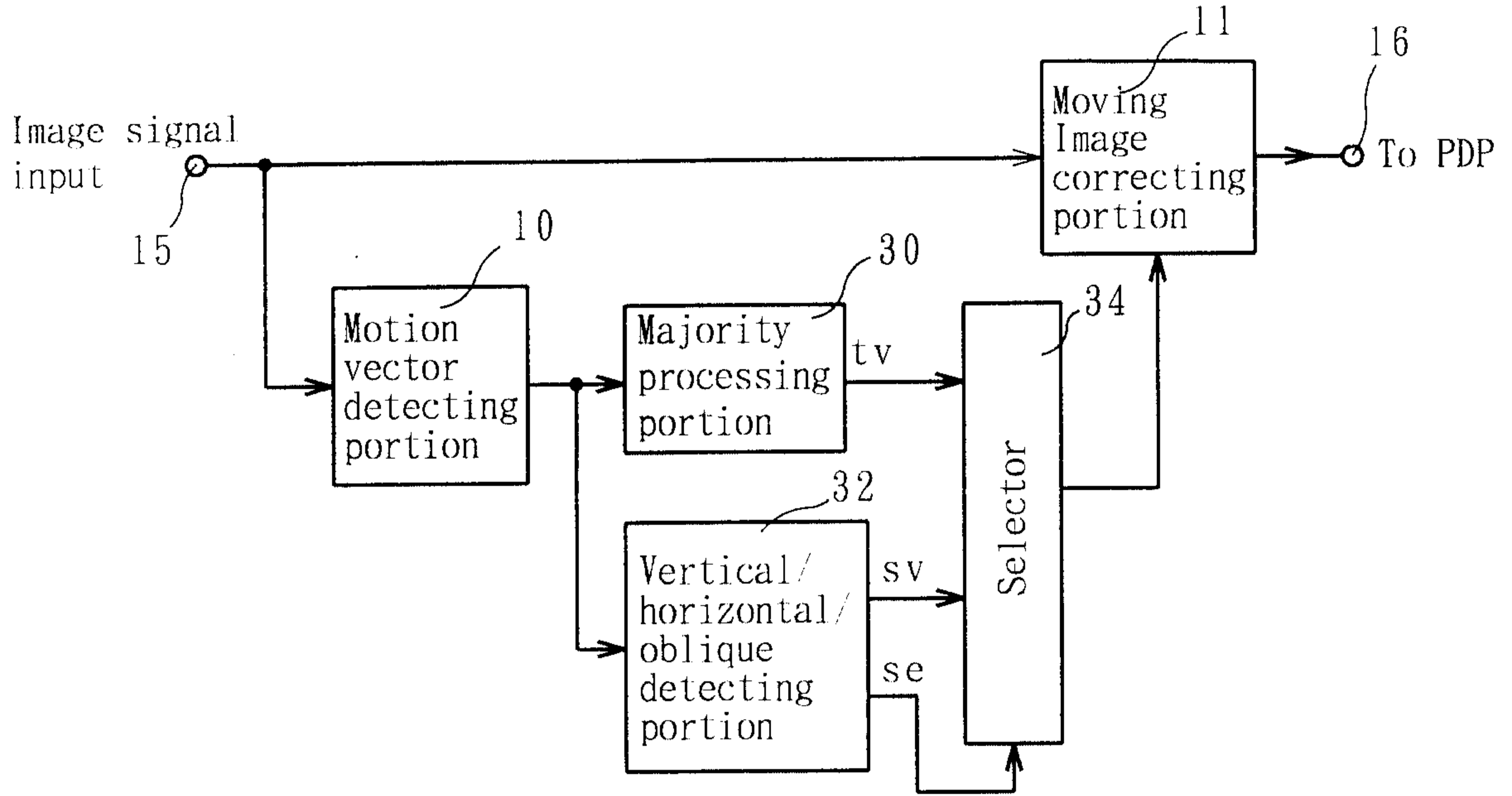

Fig. 14

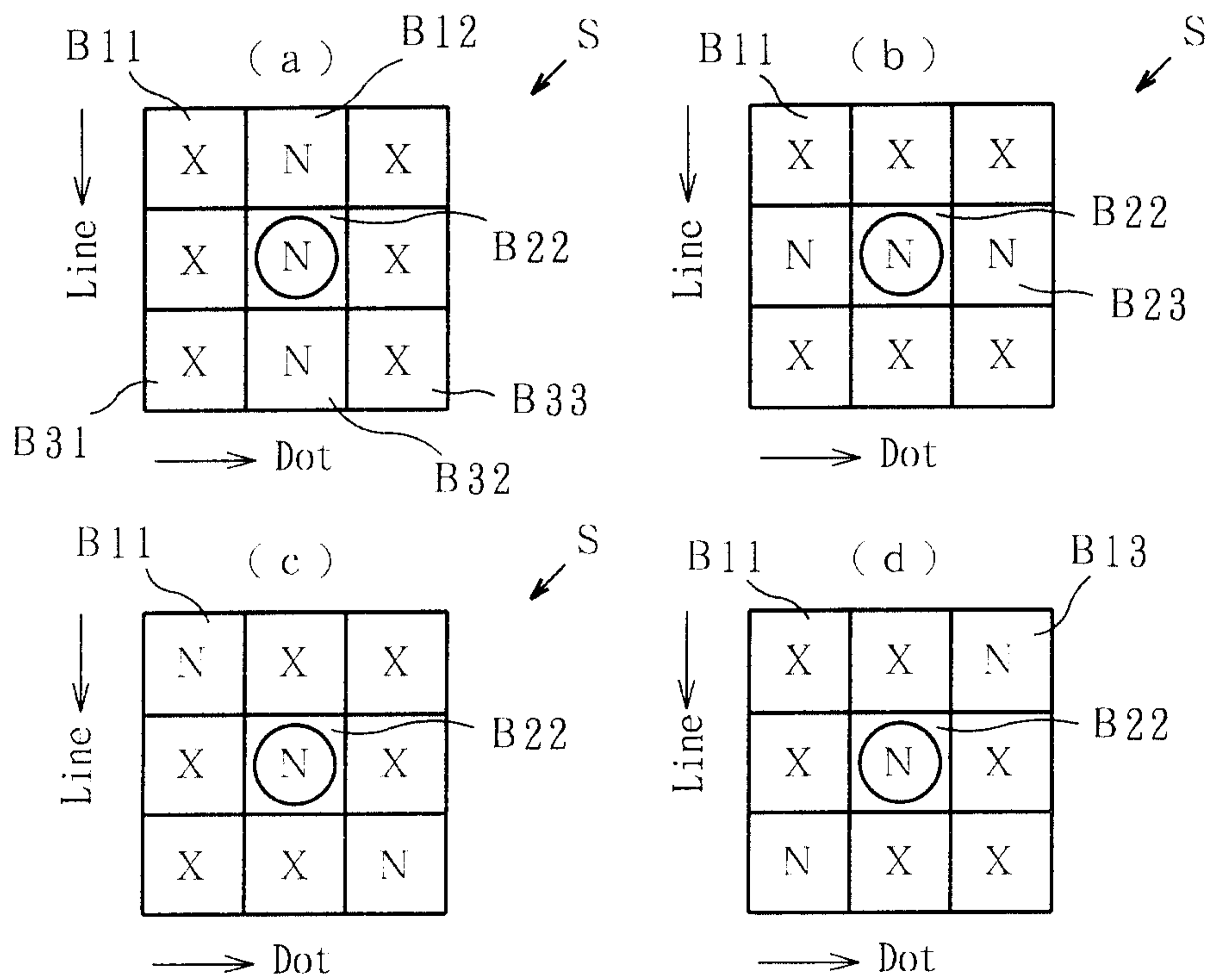

Fig. 15

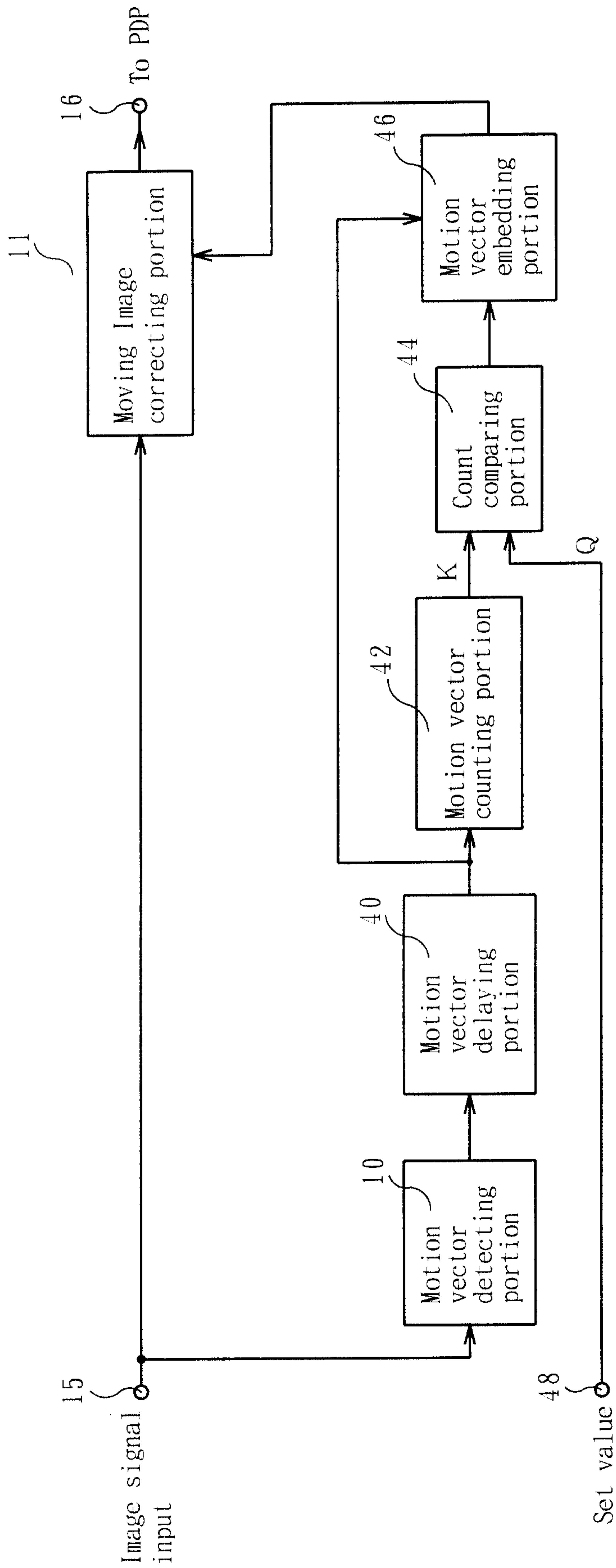

Fig. 16

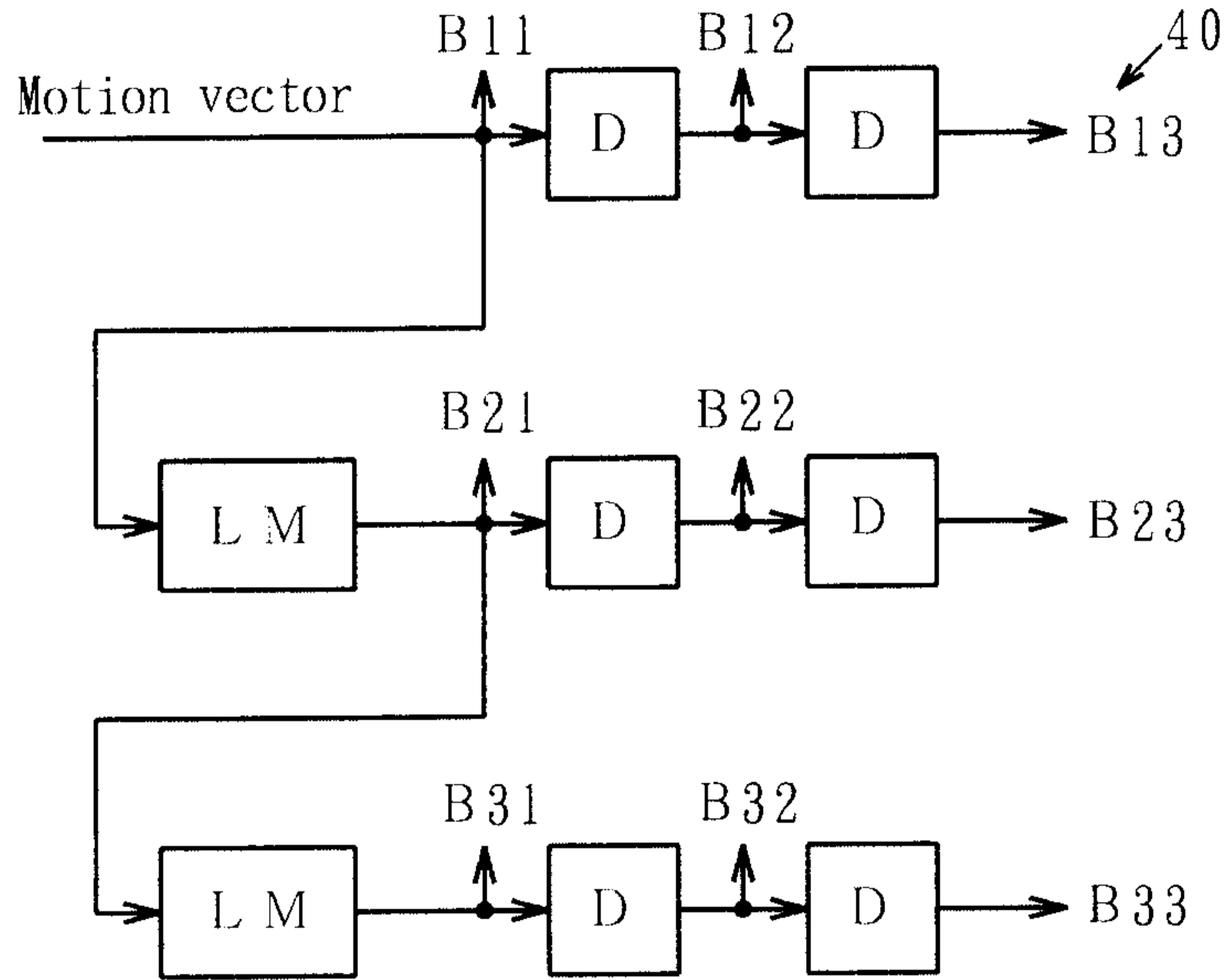

Fig. 17

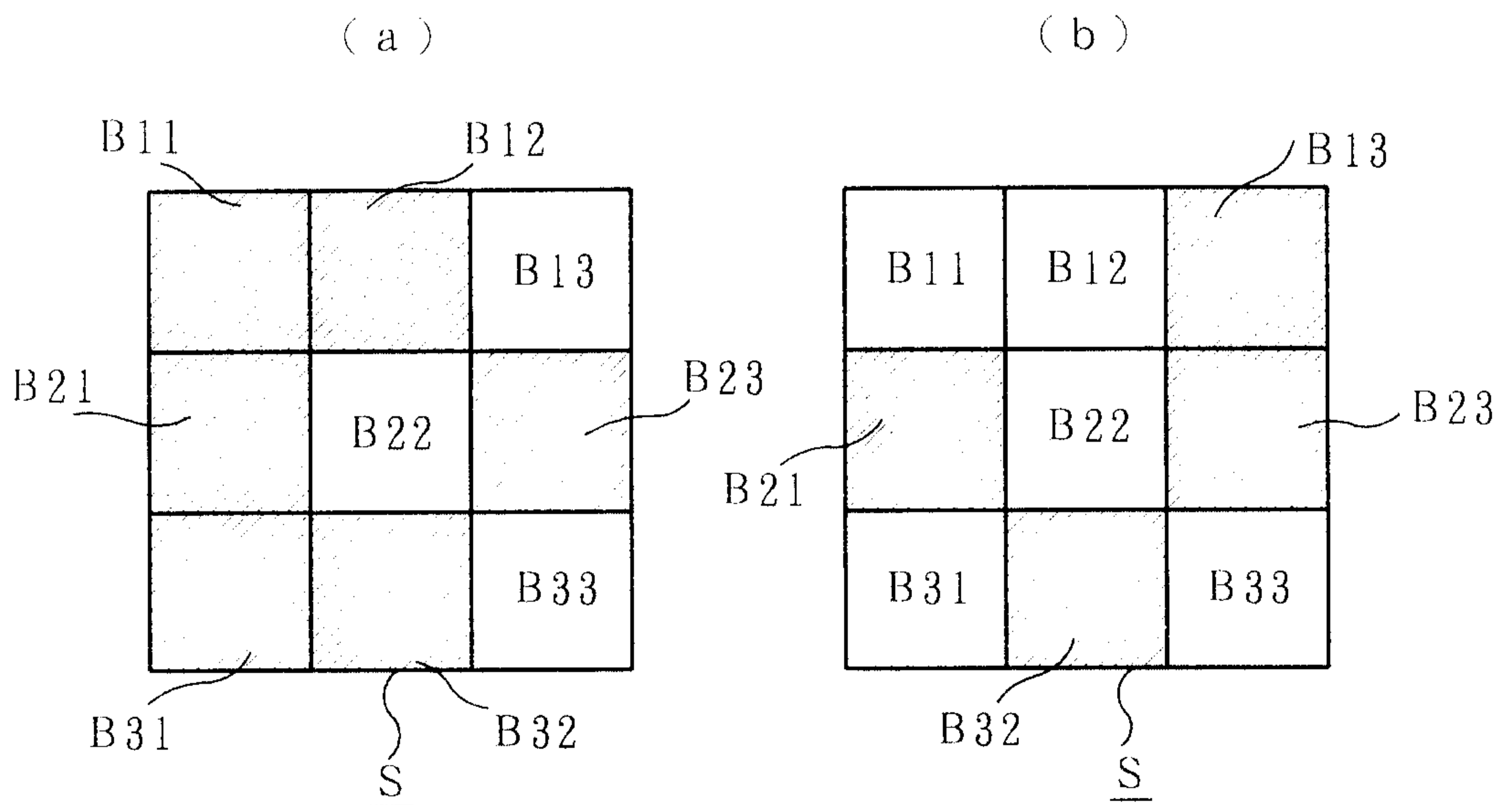

Fig. 18

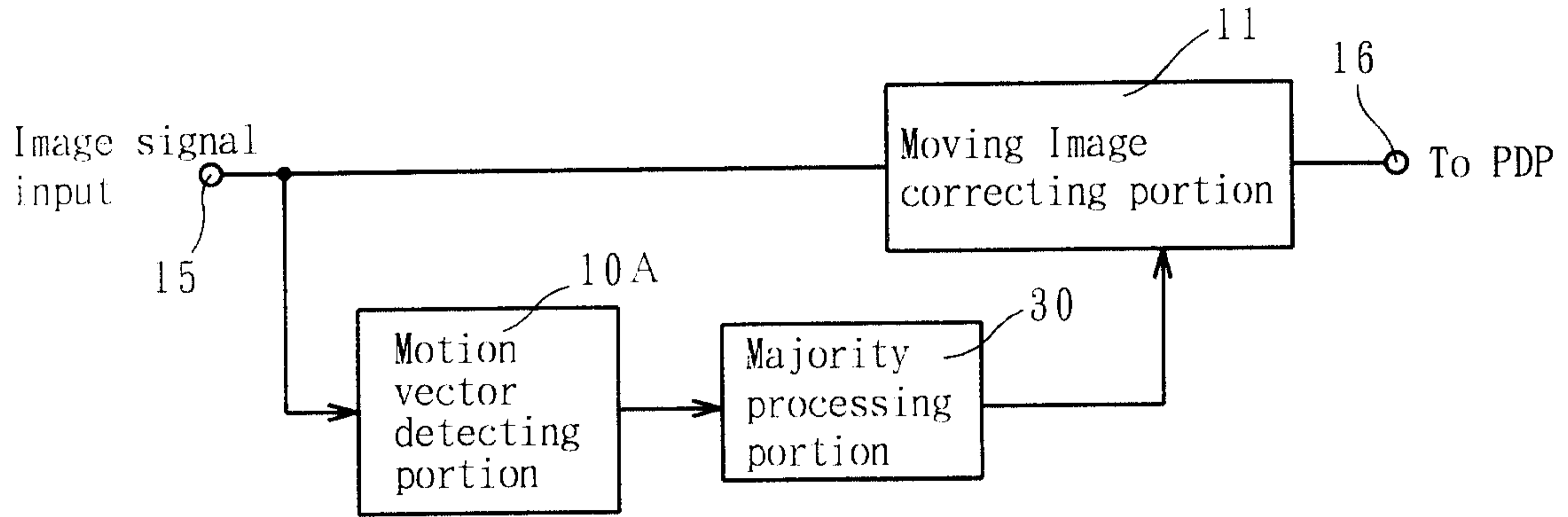

Fig. 19

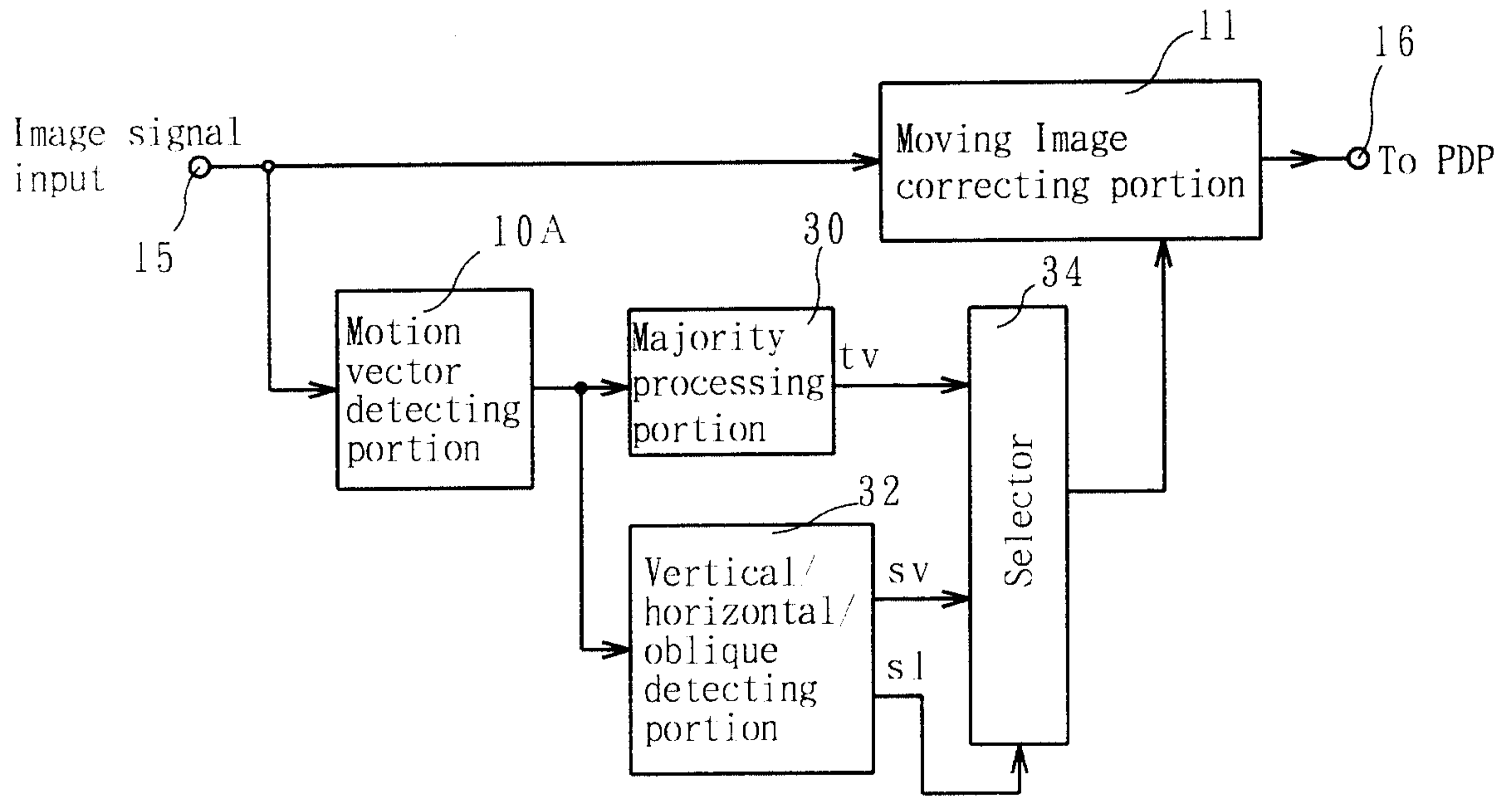

Fig. 20

