

Dec. 7, 1954

J. A. ESKEW
HOIST DRUM EQUALIZER
Filed May 29, 1952

2,696,366

Fig. 1

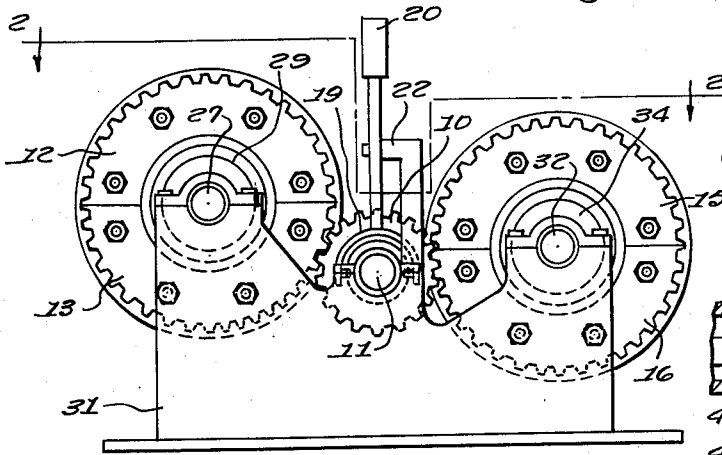

Fig. 4.

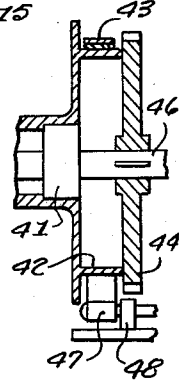

Fig. 2.

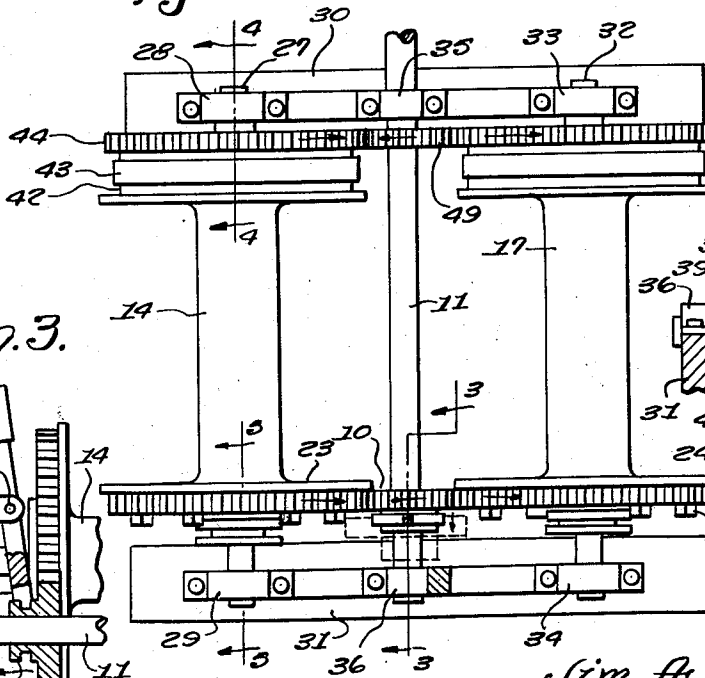

Fig. 5.

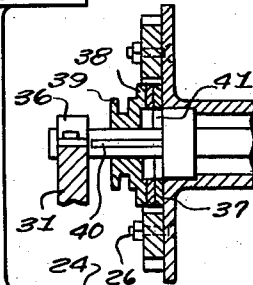
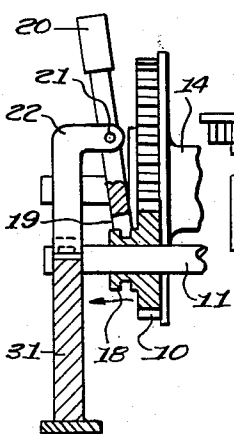

Fig. 3.



INVENTOR.
Jim A. Eskew,
BY Victor J. Evans & Co.
ATTORNEYS

1

2,696,366

HOIST DRUM EQUALIZER

Jim A. Eskew, Fort Pierce, Fla.

Application May 29, 1952, Serial No. 290,680

1 Claim. (Cl. 254—185)

This invention relates to winches and particularly hoisting drums as used on fishing boats for laying drag nets, and in particular a pinion positioned between and in meshing relation with gears attached to the ends of drums whereby the two drums on the ends of which the gears are mounted rotate at the same speed so that doors of a drag net suspended by cables from the drums drop with exactly the same speed.

The purpose of this invention is to provide equalizing means in hoisting drums whereby both drums rotate at the same speed and consequently prevent fouling up of the lines to doors of a drag net being lowered by the drums.

In the conventional type of hoisting winch two of the drums are simultaneously released and elements being lowered by cables from the drums drop downwardly by gravity. By this means an element, such as the door of the drag net suspended by a cable from one of the drums lags behind or drops ahead of a similar door suspended by a cable from the other drum with the result that slack develops in one of the cables and the slack often causes fouling of the lines. With this thought in mind this invention contemplates gears mounted on the drums and positioned to mesh with a pinion mounted on the power or driving shaft whereby the pinion functions as an equalizer preventing one drum rotating faster than the other.

The object of this invention is, therefore, to provide equalizing means in a hoist whereby a pair of drums from which doors of a drag net are suspended by cables rotate at the same speed continuously.

Another object of the invention is to provide equalizing means for a pair of drums of a hoist that may be incorporated in a hoist of a conventional design without materially changing the structure thereof.

A further object of the invention is to provide equalizing means in the form of an attachment for a hoist in which the attachment is of a simple and economical construction.

With these and other objects and advantages in view the invention embodies gears mounted on the ends of drums of a hoist, a pinion mounted on a driving shaft of the hoist and positioned to mesh with the gears on the ends of the drums, and friction clutches positioned to coact with the gears and pinions.

Other features and advantages of the invention will appear from the following description taken in connection with the drawing, wherein:

Figure 1 is an end elevational view of a hoist having a pair of drums showing the equalizing attachment mounted in combination with the drums and driving shaft of the hoist.

Figure 2 is a plan view of the hoist illustrating the position of the equalizing attachment thereon, said view being taken on line 2—2 of Fig. 1.

Figure 3 is a cross section taken on line 3—3 of Fig. 2 illustrating the auxiliary pinion with a lever and yoke for shifting the pinion into meshing relation with the gears or for withdrawing the pinion from the gears.

Figure 4 is a cross section taken on line 4—4 of Fig. 2 showing the conventional brake drums and gears on the opposite ends of the drums.

Figure 5 is a section taken on line 5—5 of Fig. 2 illustrating one of the clutches at the ends of the drums.

Referring now to the drawing wherein like reference characters denote corresponding parts the improved equalizing attachment for hoisting drums of this inven-

2

tion includes a pinion 10 mounted on a drive shaft 11 and positioned to mesh with a gear formed with sections 12 and 13 on a drum 14 and also with a gear formed with sections 15 and 16 on a drum 17 and, as illustrated in Fig. 3 the pinion 10 is provided with a clutch collar 18 that is positioned to be engaged by a yoke 19 of a hand lever 20 which is pivotally mounted by a pin 21 in a support 22.

By this means the pinion 10 may be shifted from the position shown in Fig. 3 whereby the teeth of the pinion are spaced from the teeth of the gears on the ends of the drums, when it is not desired to use the equalizing device, and when the device is used for holding the doors of a drag net to permit simultaneous travel of the doors downwardly into the water the pinion is shifted to the position shown in Fig. 3 wherein it meshes with the gears on the ends of the drums.

In the design shown the sections of the gears are secured to flanges 23 and 24 of the drums 14 and 17, respectively, with nuts 25 on studs 26. It will be understood, however, that the gears, which may be formed in sections as shown in Fig. 1 to facilitate installation thereof on the ends of the drums, or of continuous discs, may be secured to the ends of the drums by other suitable means.

In the design shown the drum 14 is mounted on a shaft 27 which is journaled with bearings 28 and 29 on supports 30 and 31 and the drum 17 is mounted on a similar shaft 32 that is journaled in bearings 33 and 34 also mounted on the supports. The driving shaft 11 is journaled in bearings 35 and 36 on the intermediate sections of the supports.

Each of the drums 14 and 17 is provided with a clutch ring, as indicated by the numeral 37 and the ring 37 is positioned to engage a similar ring or sleeve 38 on a clutch collar 39 which is slidably mounted on the shaft upon which the drum is mounted. The clutch collars are keyed to the shaft with keys 40 and suitable yokes and levers may be provided for actuating the collars. These parts are conventional and being provided with the hoist, are not described in detail and the operating means therefor, are not shown.

The drums 14 and 17 are journaled on the shafts 27 and 32 with the bearings, as indicated by the numerals 41 positioned in the ends of the drums.

The gear and brake assembly on the opposite side of the hoist is conventional, each drum being provided with a brake drum 42 having a brake band 43 thereon and gears 44 and 45 are keyed to the shafts 27 and 32 with keys 46. The brake drums are actuated by clamping elements, as indicated by the numerals 47 which are mounted on flanges 48 of the support 30. The gears 44 and 45 are positioned to mesh with a pinion 49 that is keyed to the driving shaft 11.

It is to be noted that the pinion 10 can be shifted outwardly so that its teeth do not mesh with the teeth on the gears adjacent thereto and with the pinion 10 out of engagement with the gears secured to the ends of the drums, the hoist can be used as a conventional hoist. The pinion 10 which is slidable on the shaft 11, acts as an equalizer for the pair of drums, and the pinion 49 is a power gear. The pinion 49 turns all the time that the hoist is in operation.

Thus, in the event that it is desired to lower tongs or a dragnet, the pinion 10 can be manually shifted to the position shown in Figure 2 so that the pinion 10 will mesh with the gears that are mounted on the ends of the drums 14 and 17. Thus, by using pinion 10 which is loose and slidable on its shaft, the pinion 10 can be meshed with the gears on the ends of the loose drums 14 and 17 to thereby equalize the drums so that the drums will rotate at the same speed.

It will be understood that modifications within the scope of the appended claim may be made in the design and arrangement of the parts without departing from the spirit of the invention.

What is claimed is:

In a hoist drum equalizer, a supporting means, a drive shaft supported by said supporting means, a pair of driven shafts arranged in spaced parallel relation on opposite sides of said drive shaft and supported by said supporting

3

4

means, a first drum mounted on one of said driven shafts, a second drum mounted on the other of said driven shafts, a first gear secured to one end of each of said drums, second gears connected to said driven shafts at the opposite end of the drums from said first gears, a first pinion positioned on said drive shaft and mounted for movement into and out of meshing engagement with said first gears, a clutch collar arranged contiguous to said pinion for moving said first pinion into and out of engagement with said first gears, a hand lever for moving said clutch collar, a clutch ring connected to each of said drums, a clutch collar slidably mounted on each of said driven shafts and including a sleeve engaged by said clutch ring, said clutch collars being keyed to

said driven shafts, a brake connected to each of said drums adjacent said second gears, and a second pinion mounted on said drive shaft and meshing with said second gears, whereby when the clutches on the driven shafts are disengaged and when said first pinion meshes with said first gears, said drums will rotate at the same speed.

References Cited in the file of this patent

UNITED STATES PATENTS

Number	Name	Date
2,047,494	Schat -----	July 14, 1936
2,221,359	Nesbitt -----	Nov. 12, 1940
2,572,347	Johnson -----	Oct. 23, 1951