



US00D894792S

(12) **United States Design Patent**
Micacchi

(10) **Patent No.:** **US D894,792 S**

(45) **Date of Patent:** **** Sep. 1, 2020**

(54) **BICYCLE FRAME**

(71) Applicant: **Nicola Micacchi**, Rieti (IT)

(72) Inventor: **Nicola Micacchi**, Rieti (IT)

(73) Assignee: **MOHAWKNEE S.R.L.**, Rieti (IT)

(**) Term: **15 Years**

(21) Appl. No.: **29/653,302**

(22) Filed: **Jun. 14, 2018**

(30) **Foreign Application Priority Data**

Dec. 15, 2017 (IT) 402017000145057

(51) **LOC (12) Cl.** **12-11**

(52) **U.S. Cl.**
USPC **D12/111**

(58) **Field of Classification Search**
USPC D12/111, 117; D21/412, 414, 419,
D21/423-428, 431-435
CPC B62K 3/00; B62K 3/02; B62K 3/06
See application file for complete search history.

(56) **References Cited**

U.S. PATENT DOCUMENTS

D491,111 S *	6/2004	Mizuta	D12/111
7,377,535 B2 *	5/2008	Chamberlain	B62K 19/34 280/249
D670,208 S *	11/2012	Frenzel	D12/111
D672,690 S *	12/2012	Augustin	D12/111
D694,156 S *	11/2013	Taipalus	D12/111
D719,488 S *	12/2014	Stafford	D12/111
8,931,793 B2 *	1/2015	Klieber	B62J 11/19 280/283
D727,215 S *	4/2015	Yang	D12/111
D741,221 S *	10/2015	Haller	D12/111
D783,460 S *	4/2017	Beale	D12/111
9,616,966 B2 *	4/2017	Talavasek	B62M 6/40

D797,610 S *	9/2017	Jankura	D12/111
D807,232 S *	1/2018	Bailie	D12/111
D811,946 S *	3/2018	Williams	D12/111
D828,231 S *	9/2018	Yan	D12/111
D833,333 S *	11/2018	Yu	D12/111
D845,178 S *	4/2019	Yan	D12/111
D847,033 S *	4/2019	Yan	D12/111
D858,359 S *	9/2019	Lentz	D12/111
2013/0221633 A1 *	8/2013	Jankura	B62K 19/30 280/274

* cited by examiner

Primary Examiner — Darlington Ly

(74) *Attorney, Agent, or Firm* — Lucas & Mercanti, LLP

(57) **CLAIM**

The ornamental design for a bicycle frame, as shown and described.

DESCRIPTION

FIG. 1 is a right side elevation view of a bicycle frame showing my new design;
 FIG. 2 is a left side elevation view thereof;
 FIG. 3 is a top plan view thereof;
 FIG. 4 is an exploded perspective view of the main triangular portion thereof;
 FIG. 5 is a front and right side perspective view thereof;
 FIG. 6 is a rear and right side perspective view thereof;
 FIG. 7 is a front and right side perspective view of the main horizontal tube portion thereof;
 FIG. 8 is a rear and left side perspective view of the main horizontal tube portion thereof;
 FIG. 9 is a rear and right side perspective view of the saddle column portion thereof;
 FIG. 10 is a rear and right side perspective view of the rear fork portion thereof; and,
 FIG. 11 is a rear and left side perspective view of the rear fork portion thereof.

1 Claim, 11 Drawing Sheets

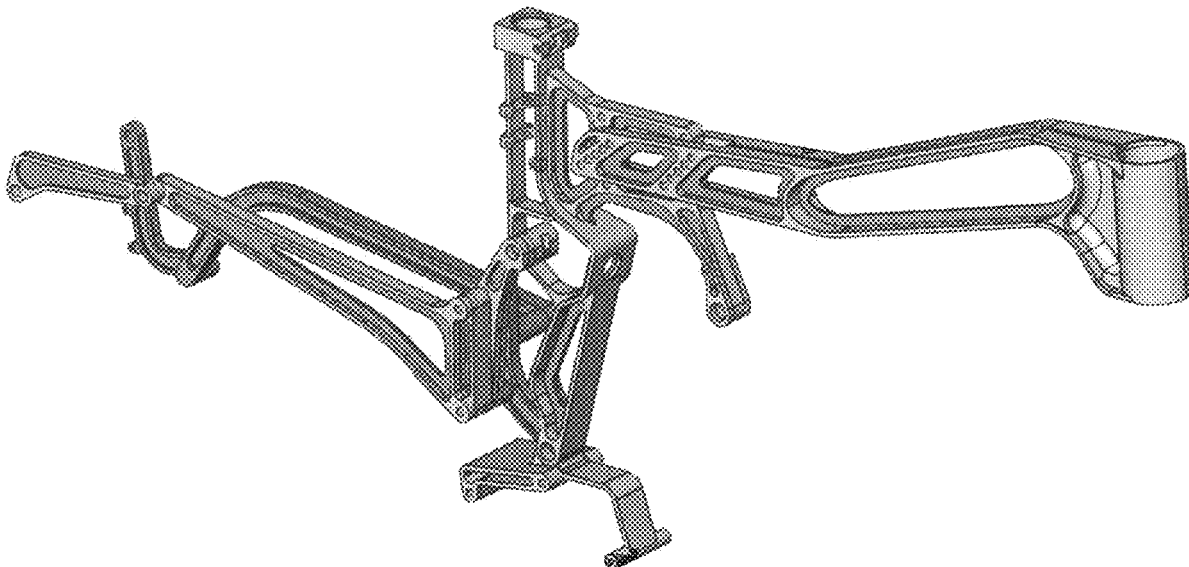

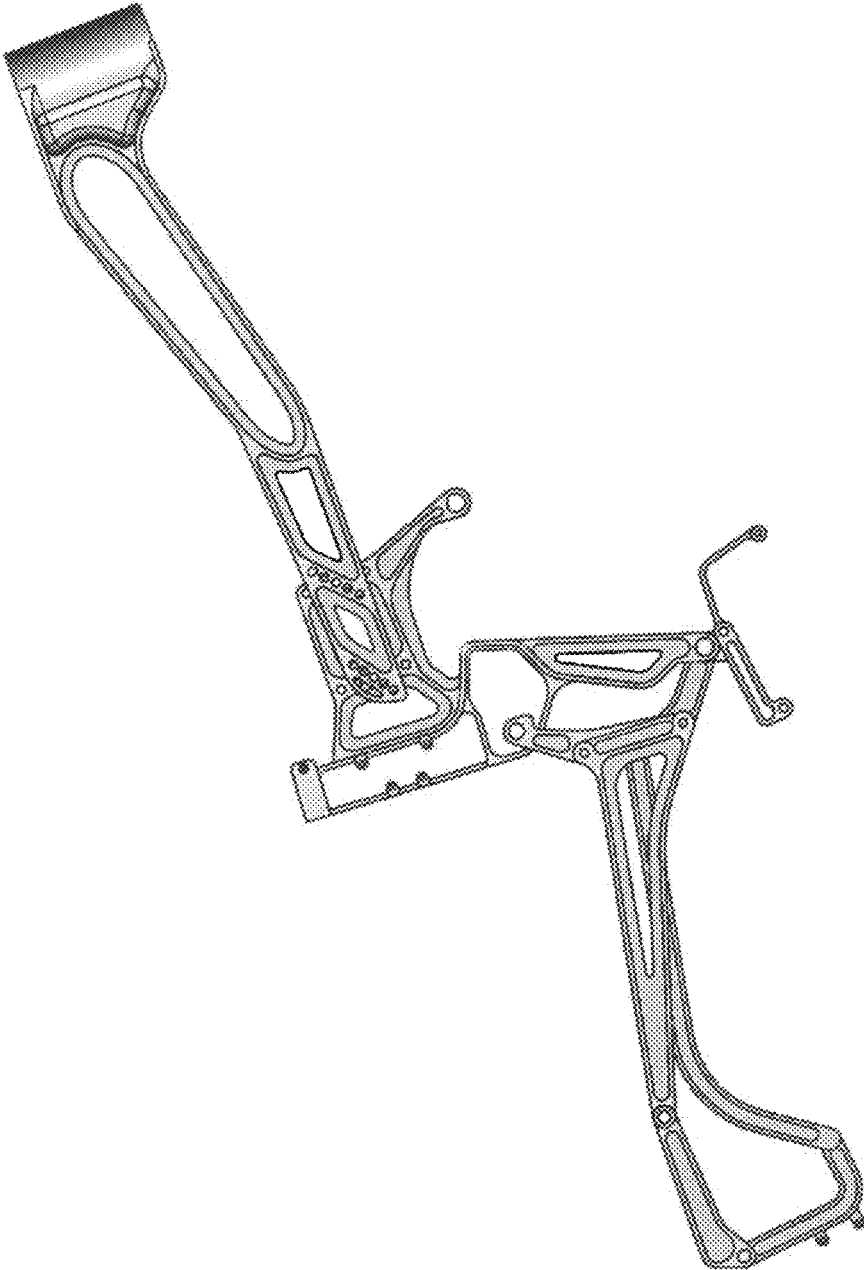

FIG.1

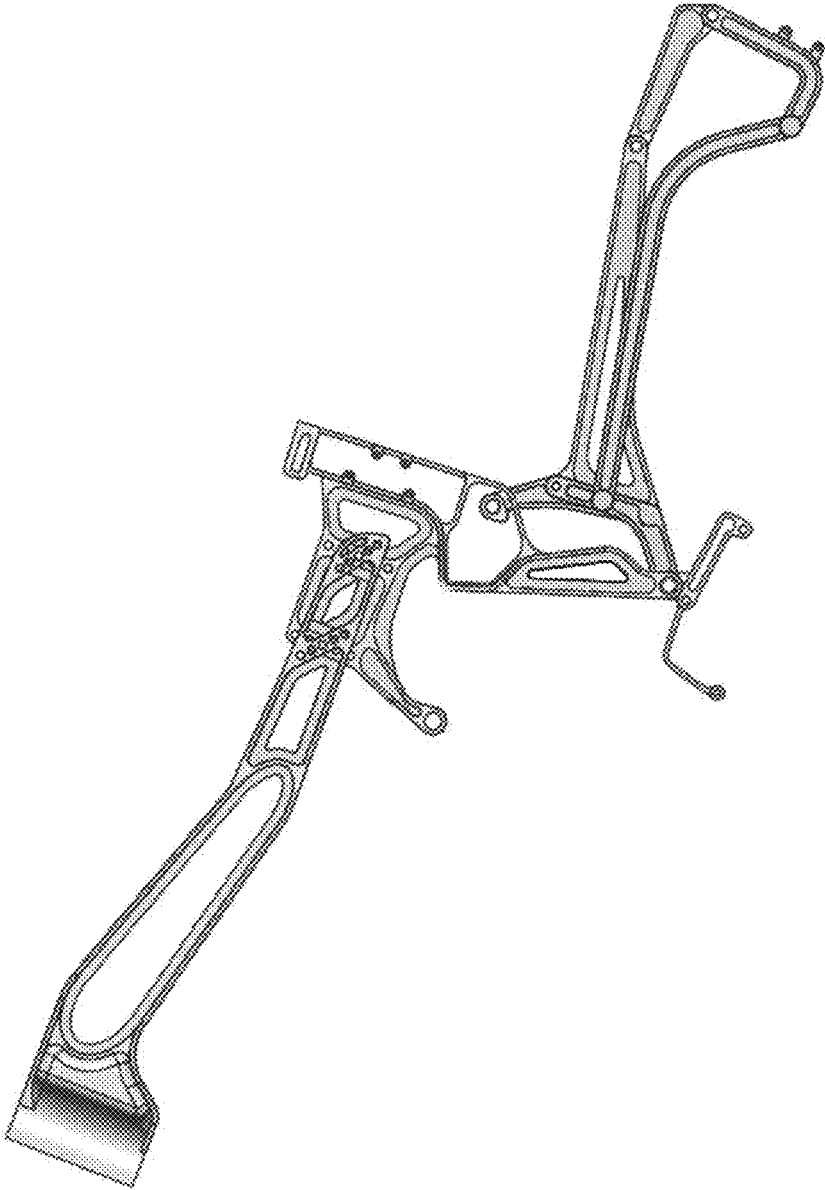

FIG.2

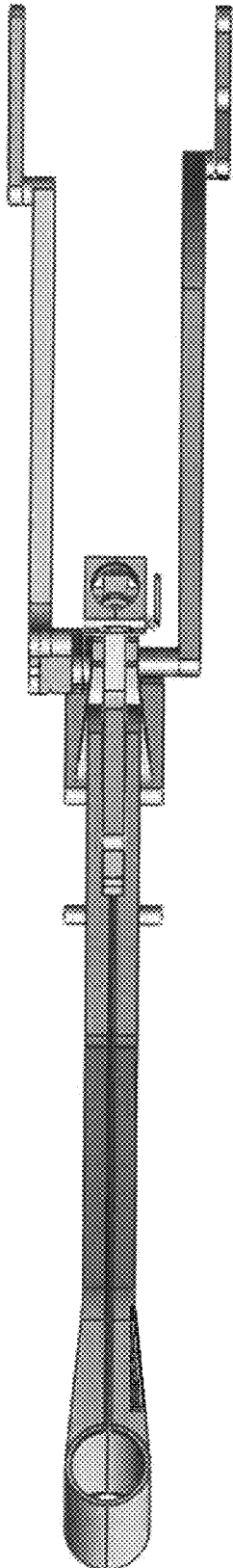

FIG.3

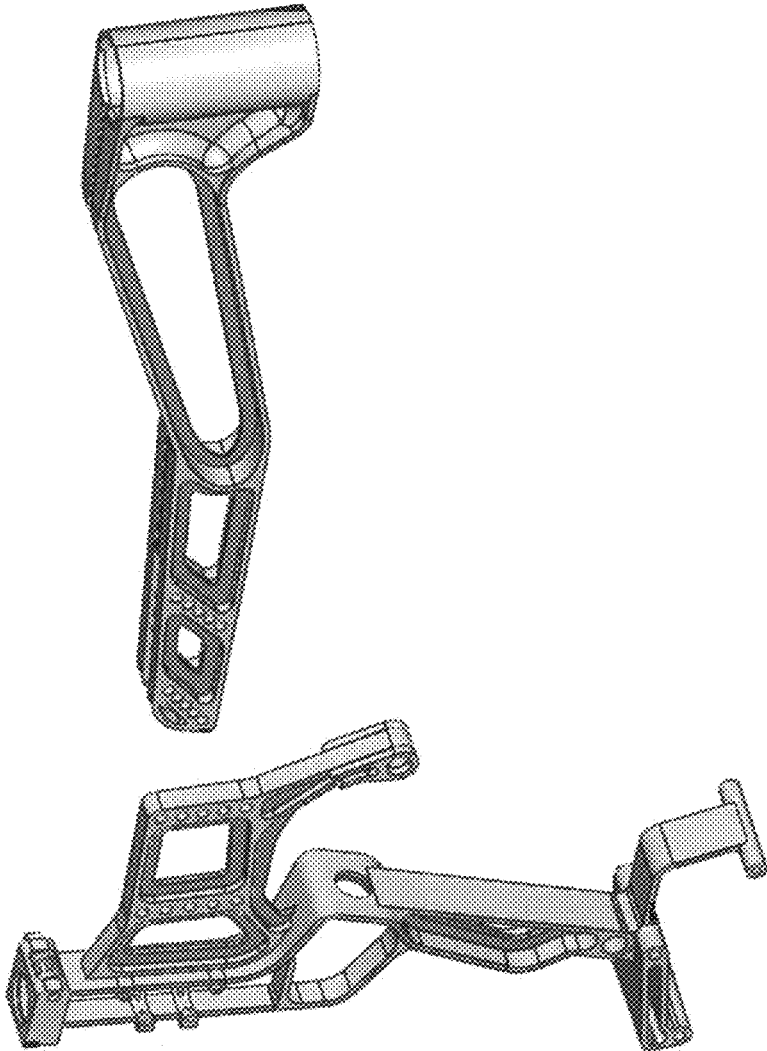

FIG.4

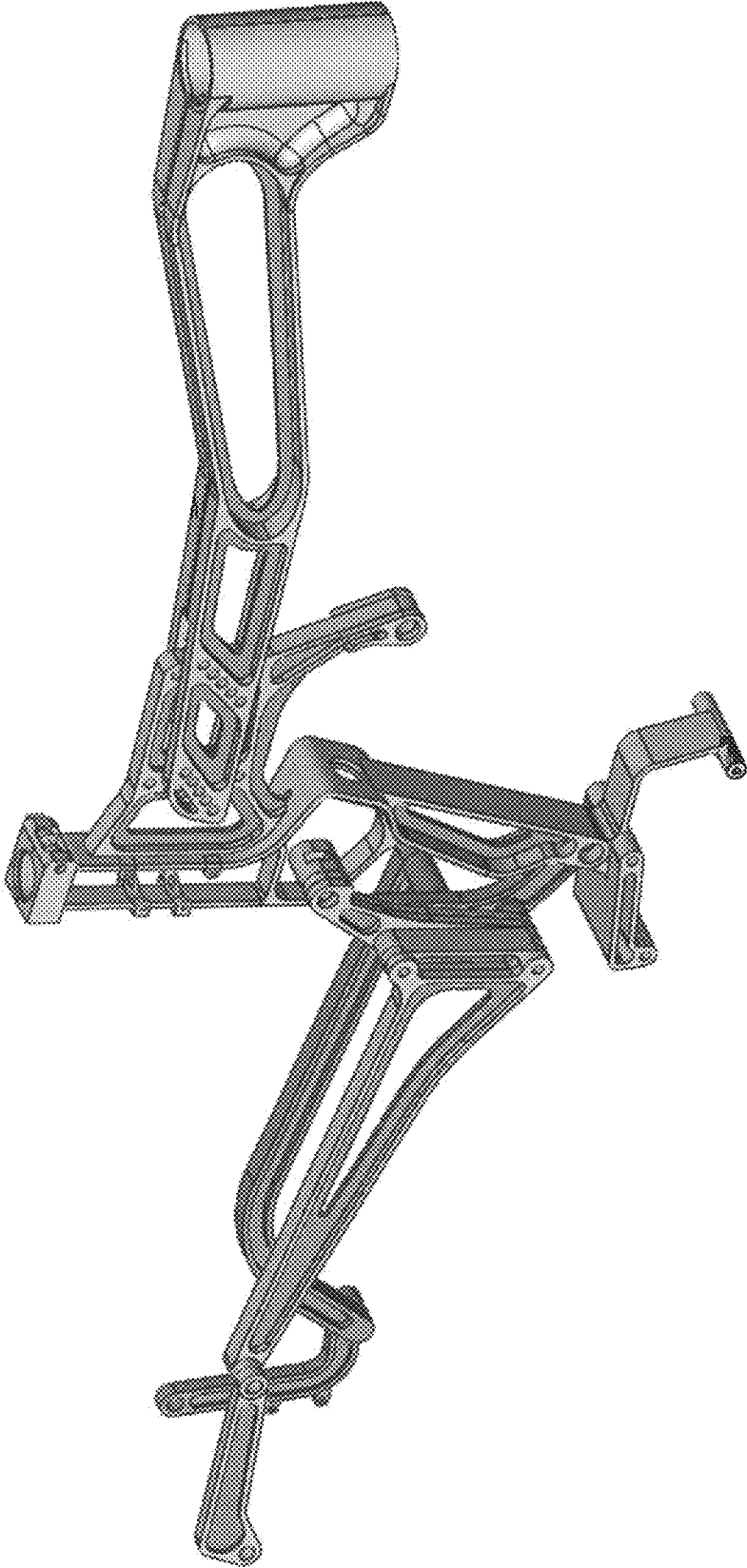

FIG.5

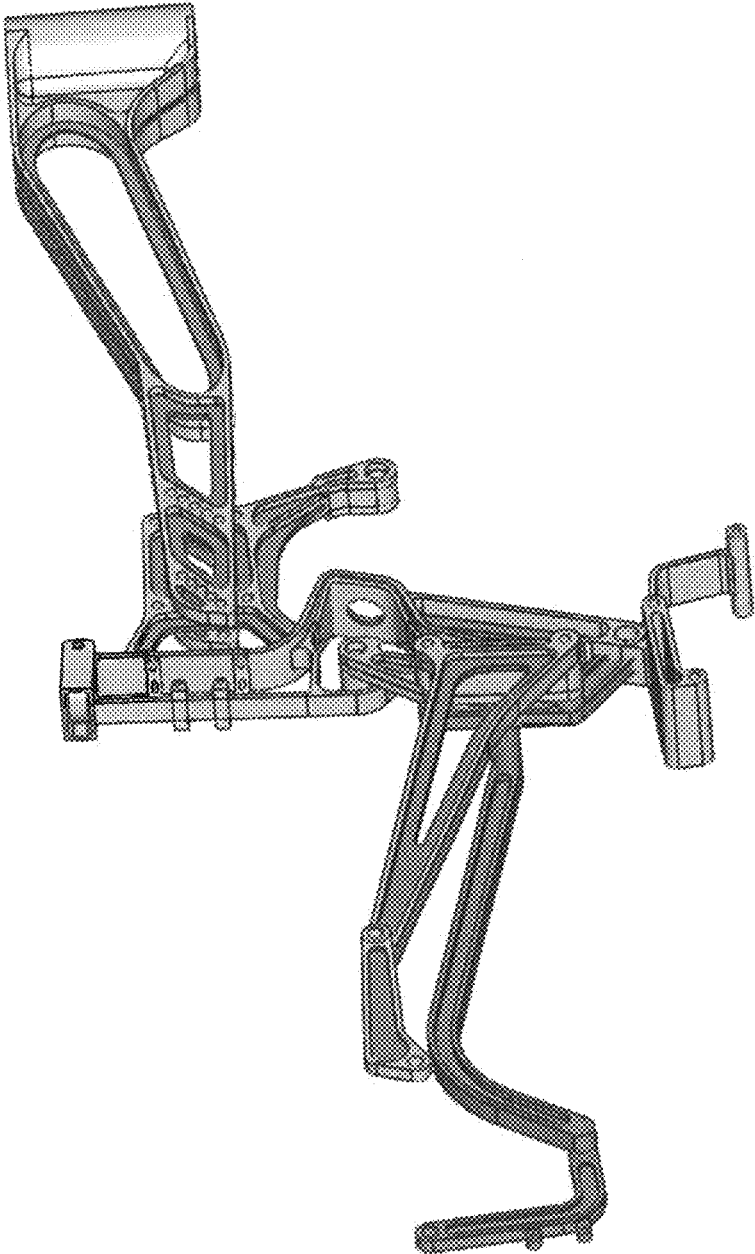

FIG.6

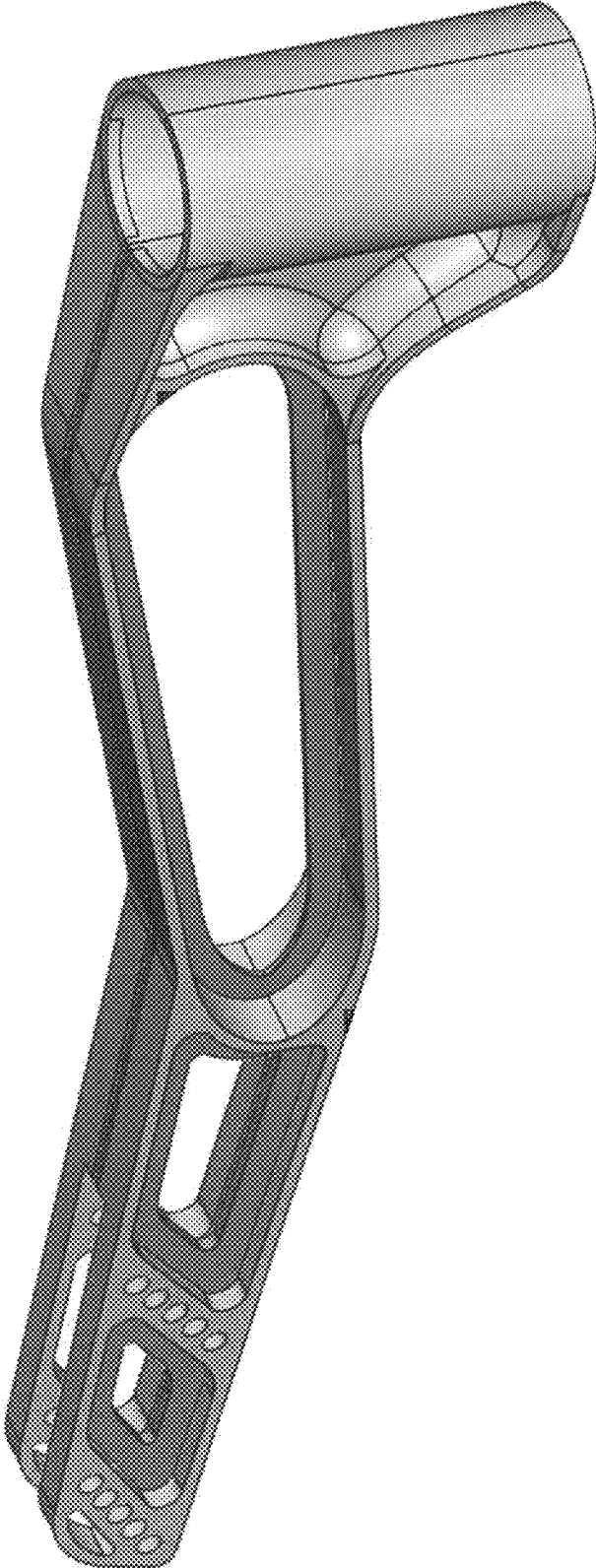

FIG.7

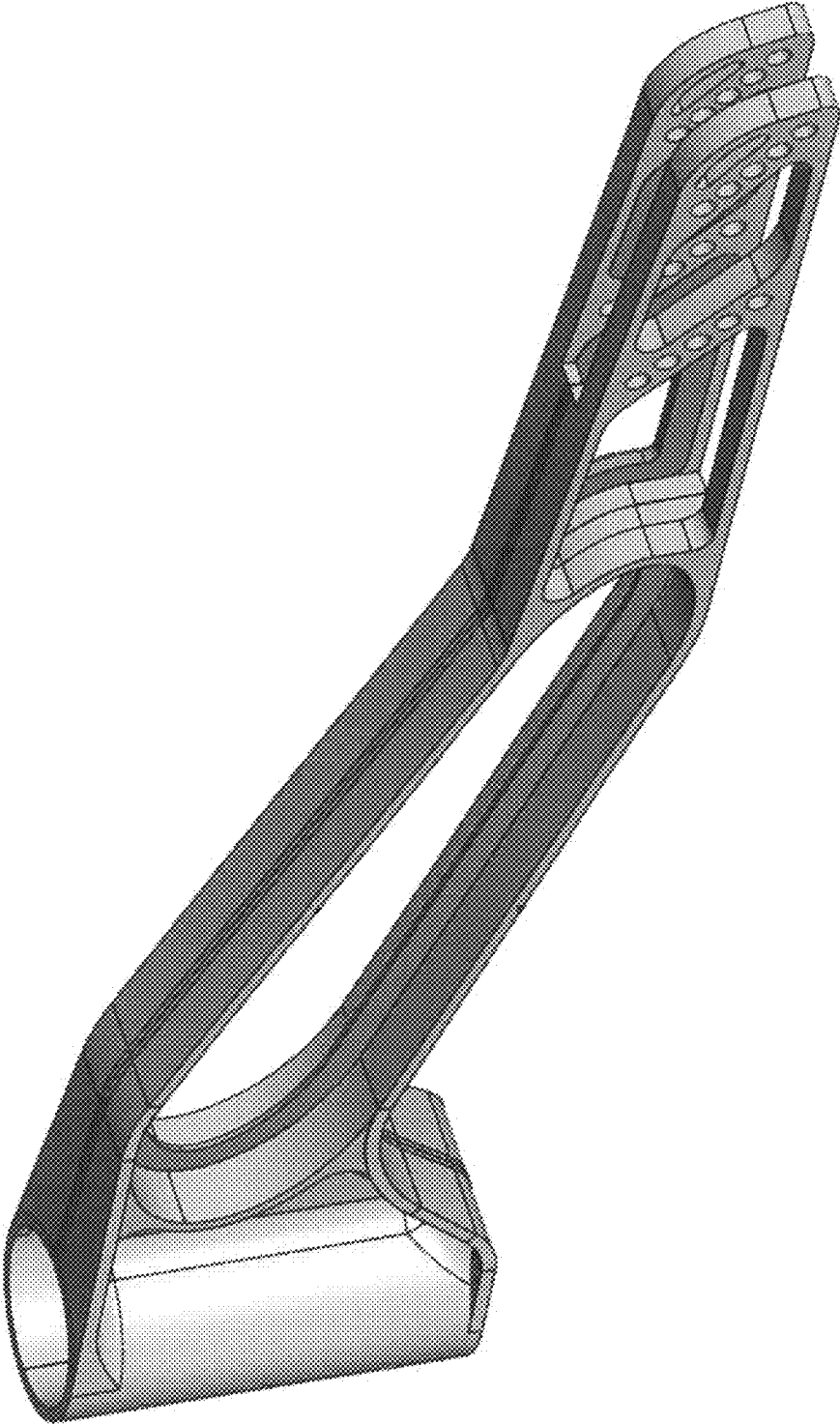

FIG.8

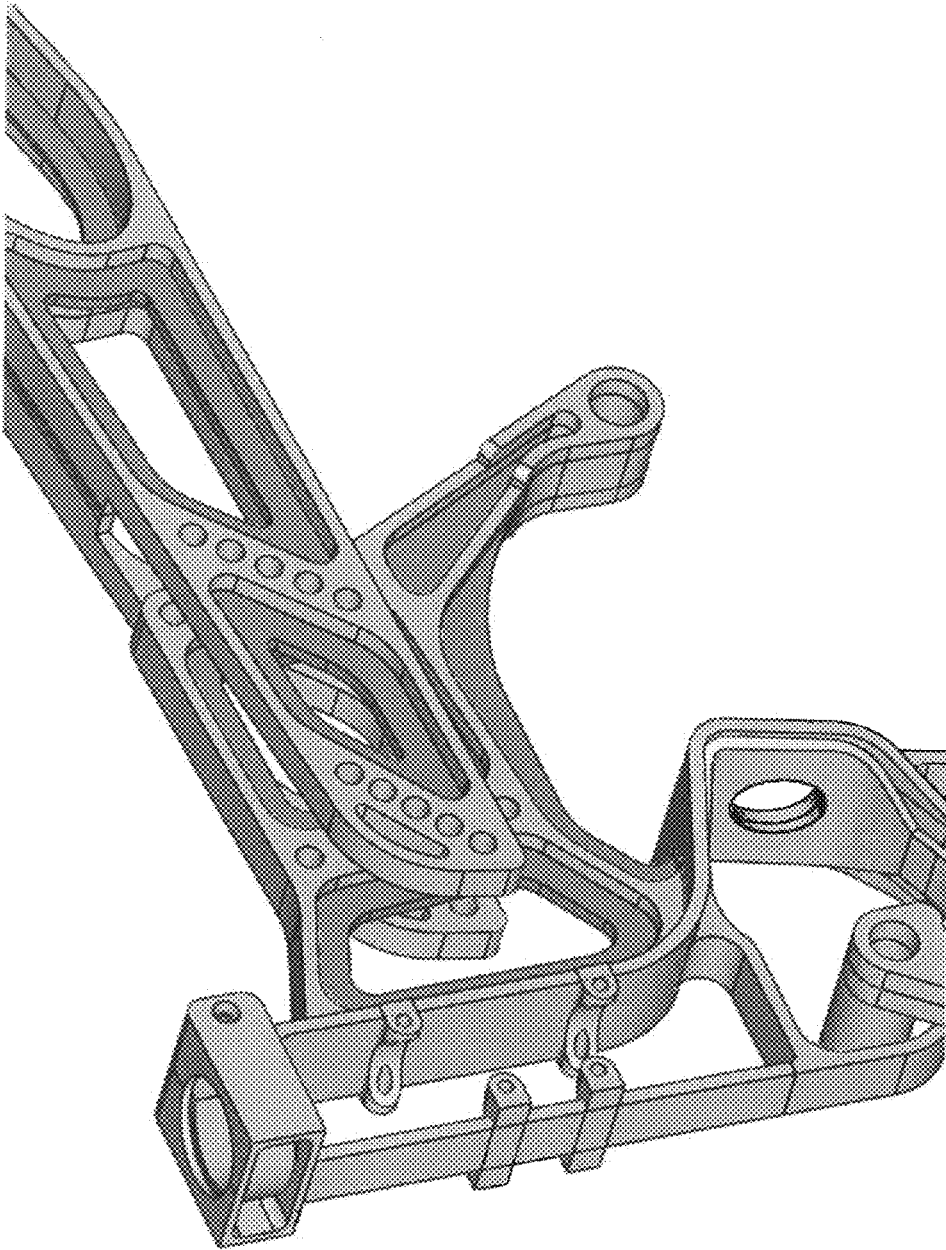

FIG.9

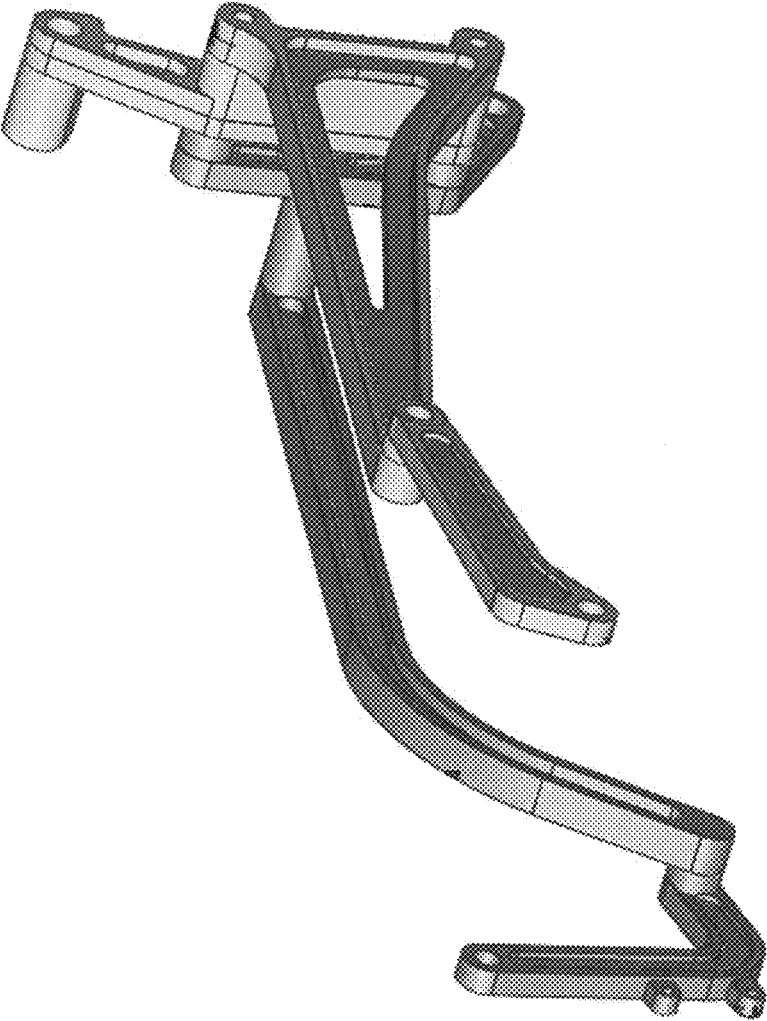

FIG.10

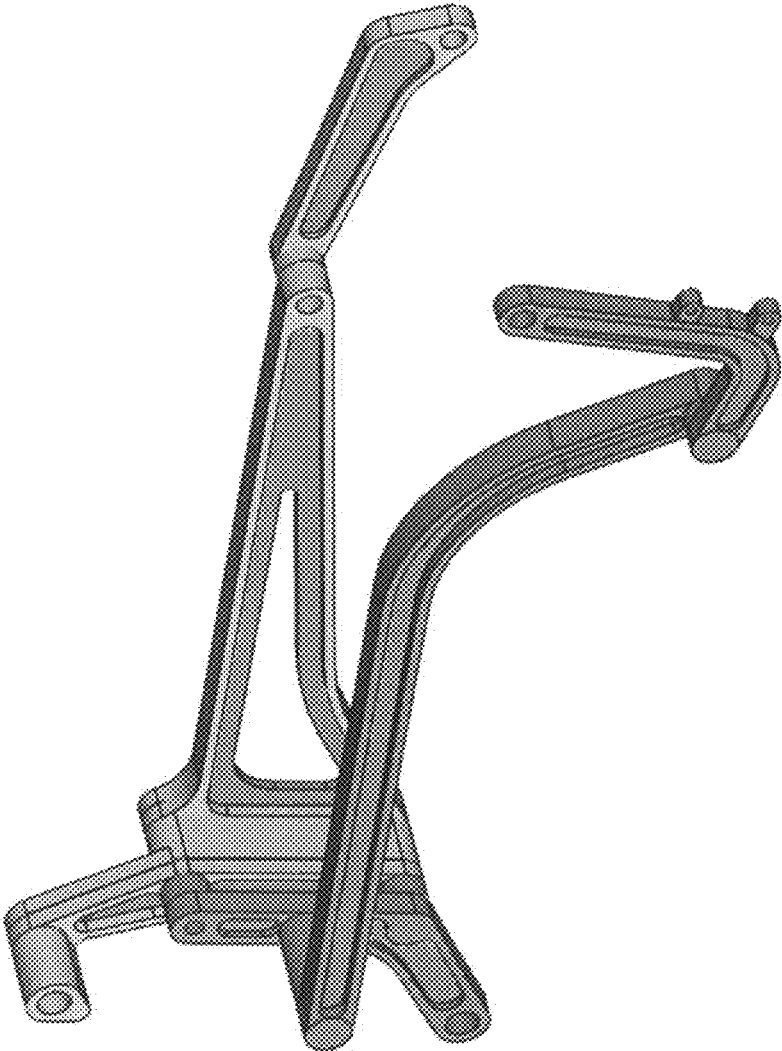

FIG.11